

# Installation

## Residential/Commercial Generator Sets



Models:

**10/12RESV(L)**

Similar Models (no longer available):

**8RESV(L)**

Controller:

**RDC2**

**▲ WARNING:** This product can expose you to chemicals, including carbon monoxide and benzene, which are known to the State of California to cause cancer and birth defects or other reproductive harm. For more information go to [www.P65warnings.ca.gov](http://www.P65warnings.ca.gov)

**Kohler strongly recommends that only factory-authorized dealers install and service the generator.**

## Product Identification Information

Product identification numbers determine service parts. Record the product identification numbers in the spaces below immediately after unpacking the products so that the numbers are readily available for future reference. Record field-installed kit numbers after installing the kits.

### Generator Set Identification Numbers

Record the product identification numbers from the generator set nameplate(s).

Model Designation \_\_\_\_\_

Specification Number \_\_\_\_\_

Serial Number: \_\_\_\_\_

### Controller Identification

Record the controller description from the generator set operation manual, spec sheet, or sales invoice.

Controller Description \_\_\_\_\_

### Engine Identification

Record the product identification information from the engine nameplate.

Manufacturer \_\_\_\_\_

Model Designation \_\_\_\_\_

Serial Number \_\_\_\_\_

Accessory Number	Accessory Description

Accessory Number	Accessory Description

# Table of Contents

<b>Safety Precautions and Instructions</b> .....	<b>5</b>
<b>Introduction</b> .....	<b>11</b>
<b>Service Assistance</b> .....	<b>13</b>
<b>Section 1. Installation</b> .....	<b>15</b>
1.1 Introduction .....	15
1.2 Lifting.....	16
1.3 Generator Set Inspection .....	16
1.4 Location and Mounting .....	16
1.4.1 Mounting Area.....	17
1.4.2 Exhaust Requirements.....	18
1.5 Dimension Drawings .....	18
1.6 Access the Air Intake Area .....	19
1.7 Fuel Requirements .....	20
1.7.1 Fuel Supply .....	20
1.7.2 Fuel Pipe Size.....	21
1.7.3 Connecting the Fuel Supply .....	21
1.8 Fuel Conversion .....	24
1.8.1 Fuel Conversion, Original Fuel System.....	25
1.8.2 Fuel Conversion, Revised Fuel System .....	28
1.9 Electrical Connections.....	30
1.9.1 Grounding .....	31
1.9.2 Electrical Lead Entry .....	32
1.9.3 Field-Connection Terminal Block .....	32
1.9.4 AC Power Supply .....	34
1.10 ATS and Accessory Connections.....	35
1.10.1 Transfer Switch Connection.....	35
1.10.2 Communication Cable Specifications.....	38
1.10.3 System Connections with Accessory Modules.....	39
1.11 Battery.....	42
1.12 Prestart Installation Check .....	44
1.13 Set the Exerciser .....	44
1.13.1 RDC2 Controller.....	44
1.13.2 Loaded Exercise .....	45
1.14 Operation Test .....	45
1.15 KOHLER Energy Management System .....	46
<b>Section 2. Accessories</b> .....	<b>47</b>
2.1 Introduction .....	47
2.2 Connect Optional Programmable Interface Module (PIM).....	47
2.3 Load Management .....	48
2.3.1 Power Relay Module .....	49
2.4 Carburetor Heater .....	50
<b>Section 3. Drawings and Diagrams</b> .....	<b>53</b>
<b>Appendix A. Abbreviations</b> .....	<b>63</b>

# Notes

# Safety Precautions and Instructions

**IMPORTANT SAFETY INSTRUCTIONS.** Electromechanical equipment, including generator sets, transfer switches, switchgear, and accessories, can cause bodily harm and pose life-threatening danger when improperly installed, operated, or maintained. To prevent accidents be aware of potential dangers and act safely. Read and follow all safety precautions and instructions. **SAVE THESE INSTRUCTIONS.**

This manual has several types of safety precautions and instructions: Danger, Warning, Caution, and Notice.



DANGER indicates a hazardous situation which, if not avoided, will result in death or serious injury.



WARNING indicates a hazardous situation which, if not avoided, could result in death or serious injury.



CAUTION indicates a hazardous situation which, if not avoided, could result in minor or moderate injury.

## NOTICE

NOTICE is used to address practices not related to physical injury.





Safety decals affixed to the equipment in prominent places alert the operator or service technician to potential hazards and explain how to act safely. The decals are shown throughout this publication to improve operator recognition. Replace missing or damaged decals.

## Accidental Starting

	<b>Accidental starting.</b> <b>Can cause severe injury or death.</b>
	Disconnect the battery cables before working on the generator set. Remove the negative (-) lead first when disconnecting the battery. Reconnect the negative (-) lead last when reconnecting the battery.

**Disabling the generator set. Accidental starting can cause severe injury or death.** Before working on the generator set or equipment connected to the set, disable the generator set as follows: (1) Press the generator set off/reset button to shut down the generator set. (2) Disconnect the power to the battery charger, if equipped. (3) Remove the battery cables, negative (-) lead first. Reconnect the negative (-) lead last when reconnecting the battery. Follow these precautions to prevent the starting of the generator set by the remote start/stop switch.

## Battery

 <b>WARNING</b>	<b>Sulfuric acid in batteries.</b> <b>Can cause severe injury or death.</b> Wear protective goggles and clothing. Battery acid may cause blindness and burn skin.
	
 <b>WARNING</b>	<b>Explosion.</b> <b>Can cause severe injury or death.</b> <b>Relays in the battery charger cause arcs or sparks.</b> Locate the battery in a well-ventilated area. Isolate the battery charger from explosive fumes.
	

**Battery electrolyte is a diluted sulfuric acid. Battery acid can cause severe injury or death.** Battery acid can cause blindness and burn skin. Always wear splashproof safety goggles, rubber gloves, and boots when servicing the battery. Do not open a sealed battery or mutilate the battery case. If battery acid splashes in the eyes or on the skin, immediately flush the affected area for 15 minutes with large quantities of clean water. Seek immediate medical aid in the case of eye contact. Never add acid to a battery after placing the battery in service, as this may result in hazardous spattering of battery acid.

**Battery acid cleanup. Battery acid can cause severe injury or death.** Battery acid is electrically conductive and corrosive. Add 500 g (1 lb.) of bicarbonate of soda (baking soda) to a container with 4 L (1 gal.) of water and mix the neutralizing solution. Pour the neutralizing solution on the spilled battery acid and continue to add the neutralizing solution to the spilled battery acid until all evidence of a chemical reaction (foaming) has ceased. Flush the resulting liquid with water and dry the area.

**Battery gases. Explosion can cause severe injury or death.** Battery gases can cause an explosion. Do not smoke or permit flames or sparks to occur near a battery at any time, particularly when it is charging. Do not dispose of a battery in a fire. To prevent burns and sparks that could cause an explosion, avoid touching the battery terminals with tools or other metal objects. Remove all jewelry before servicing the equipment. Discharge static electricity from your body before touching batteries by first touching a grounded metal surface away from the battery. To avoid sparks, do not disturb the battery charger connections while the battery is charging. Always turn the battery charger off before disconnecting the battery connections. Ventilate the compartments containing batteries to prevent accumulation of explosive gases.

**Battery short circuits. Explosion can cause severe injury or death.** Short circuits can cause bodily injury and/or equipment damage. Disconnect the battery before generator set installation or maintenance. Remove all jewelry before servicing the equipment. Use tools with insulated handles. Remove the negative (-) lead first when disconnecting the battery. Reconnect the negative (-) lead last when reconnecting the battery. Never connect the negative (-) battery cable to the positive (+) connection terminal of the starter solenoid. Do not test the battery condition by shorting the terminals together.

## Engine Backfire/Flash Fire



 <b>WARNING</b>	<b>Risk of fire.</b> <b>Can cause severe injury or death.</b>
	Do not smoke or permit flames or sparks near fuels or the fuel system.

**Servicing the air cleaner. A sudden backfire can cause severe injury or death.** Do not operate the generator set with the air cleaner removed.

**Servicing the fuel system. A flash fire can cause severe injury or death.** Do not smoke or permit flames or sparks near the carburetor, fuel line, fuel filter, fuel pump, or other potential sources of spilled fuels or fuel vapors. Catch fuels in an approved container when removing the fuel line or carburetor.

**Combustible materials. A fire can cause severe injury or death.** Generator set engine fuels and fuel vapors are flammable and explosive. Handle these materials carefully to minimize the risk of fire or explosion. Equip the compartment or nearby area with a fully charged fire extinguisher. Select a fire extinguisher rated ABC or BC for electrical fires or as recommended by the local fire code or an authorized agency. Train all personnel on fire extinguisher operation and fire prevention procedures.

## Exhaust System

 <b>WARNING</b>	<b>Carbon monoxide.</b> <b>Can cause severe nausea, fainting, or death.</b>
	The exhaust system must be leakproof and routinely inspected.

**Generator set operation. Carbon monoxide can cause severe nausea, fainting, or death.** Carbon monoxide is an odorless, colorless, tasteless, nonirritating gas that can cause death if inhaled for even a short time. Avoid breathing exhaust fumes when working on or near the generator set. Never operate the generator set inside a building. Never operate the generator set where exhaust gas could seep inside or be drawn into a potentially occupied building through windows, air intake vents, or other openings.



**Carbon monoxide detectors. Carbon monoxide can cause severe nausea, fainting, or death.** Install carbon monoxide detectors on each level of any building adjacent to the generator set. Locate the detectors to adequately warn the building's occupants of the presence of carbon monoxide. Keep the detectors operational at all times. Periodically test and replace the carbon monoxide detectors according to the manufacturer's instructions.

**Carbon monoxide symptoms. Carbon monoxide can cause severe nausea, fainting, or death.** Carbon monoxide is a poisonous gas present in exhaust gases. Carbon monoxide is an odorless, colorless, tasteless, nonirritating gas that can cause death if inhaled for even a short time. Carbon monoxide poisoning symptoms include but are not limited to the following:

- Light-headedness, dizziness
- Physical fatigue, weakness in joints and muscles
- Sleepiness, mental fatigue, inability to concentrate or speak clearly, blurred vision
- Stomachache, vomiting, nausea

If experiencing any of these symptoms and carbon monoxide poisoning is possible, seek fresh air immediately and remain active. Do not sit, lie down, or fall asleep. Alert others to the possibility of carbon monoxide poisoning. Seek medical attention if the condition of affected persons does not improve within minutes of breathing fresh air.



## Fuel System

 <b>WARNING</b>	<b>Explosive fuel vapors. Can cause severe injury or death.</b> Use extreme care when handling, storing, and using fuels.
 	

**The fuel system. Explosive fuel vapors can cause severe injury or death.** Vaporized fuels are highly explosive. Use extreme care when handling and storing fuels. Store fuels in a well-ventilated area away from spark-producing equipment and out of the reach of children. Never add fuel to the tank while the engine is running because spilled fuel may ignite on contact with hot parts or from sparks. Do not smoke or permit flames or sparks to occur near sources of spilled fuel or fuel vapors. Keep the fuel lines and connections tight and in good condition. Do not replace flexible fuel lines with rigid lines. Use flexible sections to avoid fuel line breakage caused by vibration. Do not operate the generator set in the presence of fuel leaks, fuel accumulation, or sparks. Repair fuel systems before resuming generator set operation.









**Gas fuel leaks. Explosive fuel vapors can cause severe injury or death.** Fuel leakage can cause an explosion. Check the LPG vapor or natural gas fuel system for leakage by using a soap and water solution with the fuel system test pressurized to 6–8 ounces per square inch (10–14 inches water column). Do not use a soap solution containing either ammonia or chlorine because both prevent bubble formation. A successful test depends on the ability of the solution to bubble.

## Hazardous Noise

 <b>CAUTION</b>	<b>Hazardous noise. Can cause hearing loss.</b> Never operate the generator set without a muffler or with a faulty exhaust system.
	

**Engine noise. Hazardous noise can cause hearing loss.** Generator sets not equipped with sound enclosures can produce noise levels greater than 105 dBA. Prolonged exposure to noise levels greater than 85 dBA can cause permanent hearing loss. Wear hearing protection when near an operating generator set.

## Hazardous Voltage/Moving Parts

 <b>DANGER</b>	<b>Hazardous voltage.</b> <b>Will cause severe injury or death.</b>
	This equipment must be installed and serviced by qualified electrical personnel.
 <b>DANGER</b>	<b>Hazardous voltage. Moving parts.</b> <b>Will cause severe injury or death.</b>
 	Operate the generator set only when all guards and electrical enclosures are in place.
 <b>WARNING</b>	<b>Hazardous voltage. Backfeed to the utility system.</b> <b>Can cause property damage, severe injury, or death.</b>
	If the generator set is used for standby power, install an automatic transfer switch to prevent inadvertent interconnection of standby and normal sources of supply.
 <b>CAUTION</b>	
<b>Welding the generator set.</b> <b>Can cause severe electrical equipment damage.</b> Welding on generator set will cause serious damage to engine electronic controls components. Disconnect all engine electronic control connections before welding.	

**Grounding electrical equipment. Hazardous voltage will cause severe injury or death.** Electrocutation is possible whenever electricity is present. Ensure you comply with all applicable codes and standards. Electrically ground the generator set, transfer switch, and related equipment and electrical circuits. Turn off the main circuit breakers of all power sources before servicing the equipment. Never contact electrical leads or appliances when standing in water or on wet ground because these conditions increase the risk of electrocution.



**Welding on the generator set. Can cause severe electrical equipment damage.** Before welding on the generator set perform the following steps: (1) Remove the battery cables, negative (-) lead first. (2) Disconnect all engine electronic control module (ECM) connectors. (3) Disconnect all generator set controller and voltage regulator circuit board connectors. (4) Disconnect the engine battery-charging alternator connections. (5) Attach the weld ground connection close to the weld location.

**Connecting the battery and the battery charger. Hazardous voltage will cause severe injury or death.** Reconnect the battery correctly, positive to positive and negative to negative, to avoid electrical shock and damage to the battery charger and battery(ies). Have a qualified electrician install the battery(ies).



**Short circuits. Hazardous voltage/current will cause severe injury or death.** Short circuits can cause bodily injury and/or equipment damage. Do not contact electrical connections with tools or jewelry while making adjustments or repairs. Remove all jewelry before servicing the equipment.

**Electrical backfeed to the utility. Hazardous backfeed voltage can cause severe injury or death.** Install a transfer switch in standby power installations to prevent the connection of standby and other sources of power. Electrical backfeed into a utility electrical system can cause severe injury or death to utility personnel working on power lines.

## Heavy Equipment

 <b>WARNING</b>	<p><b>Unbalanced weight.</b> <b>Improper lifting can cause severe injury or death and equipment damage.</b></p> <p>Do not use lifting eyes. Lift the generator set using lifting bars inserted through the lifting holes on the skid.</p>
	

## Hot Parts

 <b>WARNING</b>	<p><b>Hot engine and exhaust system.</b> <b>Can cause severe injury or death.</b></p> <p>Do not work on the generator set until it cools.</p>
	

**Servicing the exhaust system. Hot parts can cause severe injury or death.** Do not touch hot engine parts. The engine and exhaust system components become extremely hot during operation.

**Servicing the engine heater. Hot parts can cause minor personal injury or property damage.** Install the heater before connecting it to power. Operating the heater before installation can cause burns and component damage. Disconnect power to the heater and allow it to cool before servicing the heater or nearby parts.

## Notice

### NOTICE

**Canadian installations only.** For standby service connect the output of the generator set to a suitably rated transfer switch in accordance with Canadian Electrical Code, Part 1.

This manual provides installation instructions for Model 8/10/12RESV(L) generator sets. See Figure 1. Refer to TP-6880, Operation Manual, for generator set operation and maintenance instructions.

The generator set is approved for use in stationary applications in locations served by a reliable utility power source.

**Note:**

The DC2 controller has been discontinued. Model 8/10/12RESV(L) generator sets built in 2019 are equipped with the RDC2 controller.

Have a authorized distributor/dealer install the generator set outdoors according to the instructions in this manual. The generator set installation must comply with the National Electrical Code (NEC) and local code requirements. Do not install this generator set indoors.

Information in this publication represents data available at the time of print. Discovery Energy, LLC reserves the right to change this publication and the products represented without notice and without any obligation or liability whatsoever.

Read this manual and carefully follow all procedures and safety precautions to ensure proper equipment operation and to avoid bodily injury. Read and follow the Safety Precautions and Instructions section at the beginning of this manual.



Figure 1 Model RESV Generator Set

## List of Related Literature

Figure 2 identifies related literature available for the generator sets covered in this manual. Only trained and qualified personnel should install or service the generator set.

Literature Type	Part Number
Spec Sheet, 8RESV(L) Discontinued	G4-252
Spec Sheet, 10/12RESV(L)	G4-254
Operation Manual, Generator Set	TP-6880
Operation/Installation Manual, Model RXT Automatic Transfer Switch	TP-6807
Operation Manual, SiteTech™ Software	TP-6701
Operation/Installation Manual, Model RDT Transfer Switch	TP-6345
Installation Instructions, Programmable Interface Module (PIM)	TT-1584
Installation Instructions, Load Shed Kit	TT-1609
Installation Instructions, USB Utility	TT-1636

Figure 2 Related Literature

## **Startup and Registration**

When the generator set is installed, complete the startup and installation checklists supplied with the startup notification form. Complete the startup notification form and register the unit using the Kohler online Warranty Processing System.

## Service Assistance



---



For professional advice and conscientious service, please contact your nearest dealer.

- Visit the Discovery Energy, LLC website at [kohlergenerators.com](http://kohlergenerators.com)
- Look at the labels and decals on your Kohler product or review the appropriate literature or documents included with the product.
- Call toll free in the US and Canada 1-800-544-2444.

# Notes

## 1.1 Introduction

 <b>DANGER</b>	<p><b>Hazardous voltage.</b> <b>Will cause severe injury or death.</b></p> <p>This equipment must be installed and serviced by qualified electrical personnel.</p>
	

 <b>WARNING</b>	<p><b>Carbon monoxide.</b> <b>Can cause severe nausea, fainting, or death.</b></p> <p>The exhaust system must be leakproof and routinely inspected.</p>
	

**Generator set operation. Carbon monoxide can cause severe nausea, fainting, or death.** Carbon monoxide is an odorless, colorless, tasteless, nonirritating gas that can cause death if inhaled for even a short time. Avoid breathing exhaust fumes when working on or near the generator set. Never operate the generator set inside a building. Never operate the generator set where exhaust gas could seep inside or be drawn into a potentially occupied building through windows, air intake vents, or other openings.

**Carbon monoxide detectors. Carbon monoxide can cause severe nausea, fainting, or death.** Install carbon monoxide detectors on each level of any building adjacent to the generator set. Locate the detectors to adequately warn the building's occupants of the presence of carbon monoxide. Keep the detectors operational at all times. Periodically test and replace the carbon monoxide detectors according to the manufacturer's instructions.

Have the generator set installed by an authorized distributor/dealer or authorized representative. Install the equipment in compliance with the National Electrical Code (NEC) and local codes. For Canadian installations, refer to the Canadian Electrical Code (CEC).

The generator set must be installed outdoors. The exhaust systems on enclosed units are designed for outdoor installation only.

**Note:**

**DO NOT** install these generator sets inside a building.

**Note:**



Install carbon monoxide (CO) detector(s) on each level of any building adjacent to a generator set. Locate the detectors to adequately warn the building's occupants of the presence of carbon monoxide.

Obtain a building permit and contact your local utility companies to mark the locations of underground pipes and cables.

Read and follow the safety precautions in this manual and observe the decals on the equipment. Refer to the diagrams and drawings in this manual for dimensions and electrical connections during the installation procedure. Read the entire installation procedure and obtain the accessories and tools needed before beginning installation. Perform the steps in the order shown.

To install optional accessories, follow the instructions provided with each kit.

## 1.2 Lifting

 <b>WARNING</b>	<p><b>Unbalanced weight.</b>  <b>Improper lifting can cause severe injury or death and equipment damage.</b></p> <p>Do not use lifting eyes. Lift the generator set using lifting bars inserted through the lifting holes on the skid.</p>
	

Approximate generator set weights are shown in Figure 3. Use lifting bars inserted through the holes in the skid to lift the unit. See the dimension drawings in the Drawings and Diagrams section for lifting hole locations.

Model	Weight, kg (lb.)
8RESV(L)	170 (375)
10RESV(L)	194 (428)
12RESV(L)	196 (433)

Figure 3 Approximate Shipping Weights

## 1.3 Generator Set Inspection

Complete a thorough inspection of the generator set. Check for the following:

1. Inspect the generator set for loose or damaged parts or wires. Repair or tighten any loose parts before installation.
2. Check the engine oil. Fill, if necessary, with the recommended viscosity and grade of oil. Use synthetic oil, API (American Petroleum Institute) Service Class SG or higher. See TP-6880, Operation Manual, for additional information.

## 1.4 Location and Mounting

Install the generator set outdoors near the incoming gas service. The generator set location must allow easy access for maintenance and service. The required distance from a structure is dependent on state and local codes. See the dimension drawing in the Drawings and Diagrams section for the minimum clearance from structures and non-combustible materials.

Locate the generator set so that the hot exhaust does not blow on plants or other combustible materials. No plants, shrubs, or other combustible materials are allowed within 1.2 m (4 ft.) of the exhaust end of the generator set.

Do not install the generator set where exhaust gas could accumulate and seep inside or be drawn into a potentially occupied building. Furnace and other similar intakes must be at least 3 m (10 ft.) from the exhaust end of the generator set.

### Notice

**DO NOT** locate the generator set near patios, decks, play areas, or animal shelters. Keep items such as lawn furniture, toys, sports equipment, and all combustible materials away from the generator set exhaust outlet.

Remind family members, children, and visitors to use caution near the generator set. Generator sets connected to automatic transfer switches start automatically during exercise periods and power outages. Some generator set components become hot when the generator set is running and remain hot for a time after the generator set shuts down.

**Note:**

The reduced minimum clearance from a structure contained in ADV-8774 and ADV-9739 only applies to generators that are compliant with clause (2) of section 4.1.4 of NFPA 37. To verify that the generator is compliant, check the **Specification Number** located on the generator name plate. See Figure 4. If the name plate displays one of the following specification numbers, then the generator is compliant with clause (2) of section 4.1.4 of NFPA 37 and the reduced clearance in ADV-8774 (the Dimension Drawing ADV-8774, Sheet 3 figure) and ADV-9739 (the Dimension Drawing ADV-9739, Sheet 3 figure) will apply.

- 8RESV: GM88347-GA7 or higher
- 8RESVL: GM88347-GA10 or higher
- 10RESV: GM114242-GA3
- 10RESVL: GM114242-GA4
- 12RESV: GM114242-GA5
- 12RESVL: GM114242-GA6

**Note:**

If the generator set name plate does not display one of the specification numbers listed above, refer to ADV-8539 in installation manual TP-6879 for the minimum clearance from a structure.

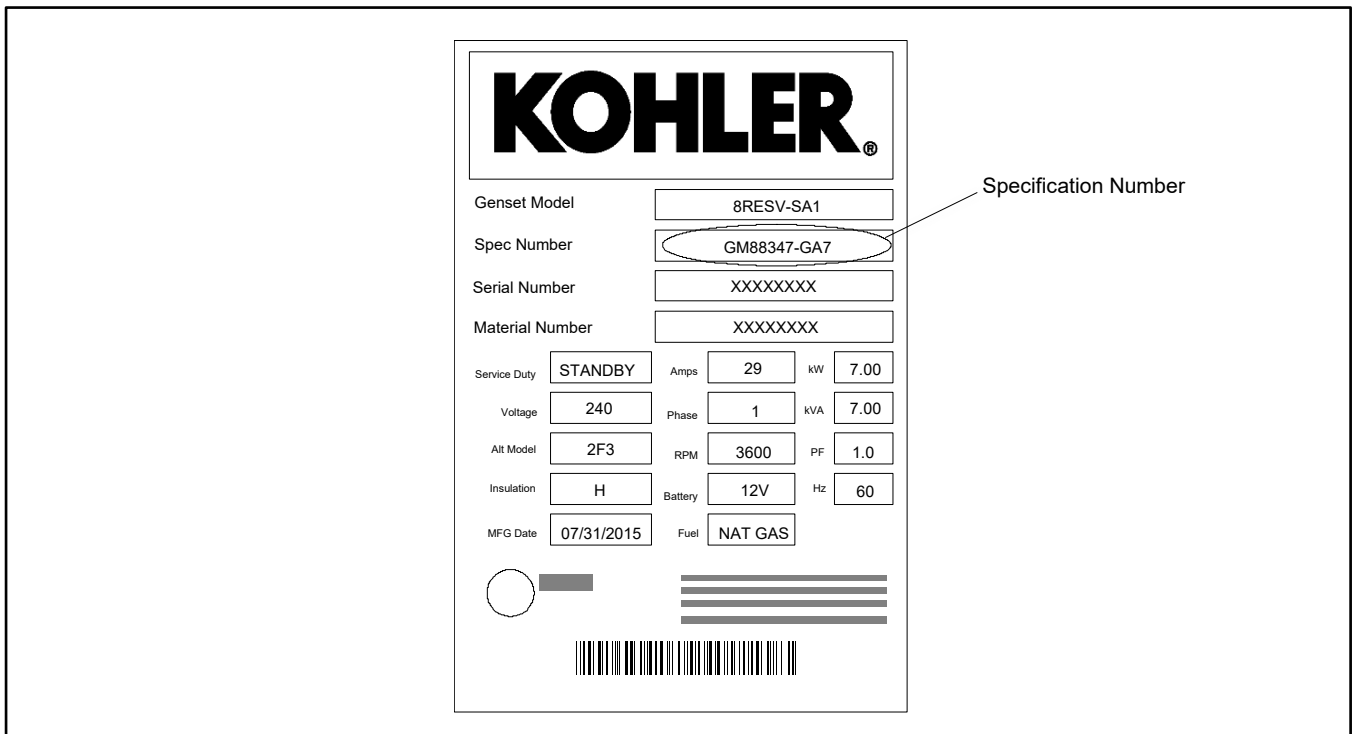

Figure 4 Name Plate

### 1.4.1 Mounting Area



The generator set is shipped on a wooden pallet. Remove the wooden pallet before positioning the generator set. Prepare a flat, level mounting area covered with a weed barrier and gravel or a concrete mounting pad. Set the generator set directly on the gravel or concrete.

**Note:**

When installing a concrete mounting pad, the generator set must be secured to the mounting pad to prevent shifting or movement caused by engine vibration. For mounting pads GM92228-KP1-QS and GM92228-KP2-QS, use the screw inserts in the mounting pad to secure the generator set. See TT-1619 for concrete mounting pad installation instructions.

Do not install the generator set directly on grass, wood, or other combustible materials. Clear all combustible materials, including plants and shrubs, building materials, and lawn furniture, from an area at least 1.2 m (4 ft.) beyond the exhaust end of the generator set. See the dimension drawing in the Drawings and Diagrams section.

## 1.4.2 Exhaust Requirements

 <b>WARNING</b>	<b>Hot engine and exhaust system. Can cause severe injury or death.</b> Do not work on the generator set until it cools.
	

**Servicing the exhaust system. Hot parts can cause severe injury or death.** Do not touch hot engine parts. The engine and exhaust system components become extremely hot during operation.

Figure 5 gives the exhaust temperature at rated load. Mount the generator set so that the hot exhaust does not blow on plants or other combustible materials. Maintain the clearances shown in the dimension drawing in the Drawings and Diagrams section.

Exhaust	Model	Temperature, °C (°F)
Exhaust gas exiting the enclosure at rated kW, °C (°F)	8RESV(L)	190 (374)
	10/12RESV(L)	106 (224)

Figure 5 Exhaust Flow and Temperature

The generator set requires correct air flow for cooling and combustion. The inlet and outlet openings in the sound enclosure provide the cooling and combustion air. Figure 6 shows the locations of the cooling air intake and exhaust vents. Inspect the air inlet and outlet openings inside and outside the housing to ensure that the air flow is not blocked.

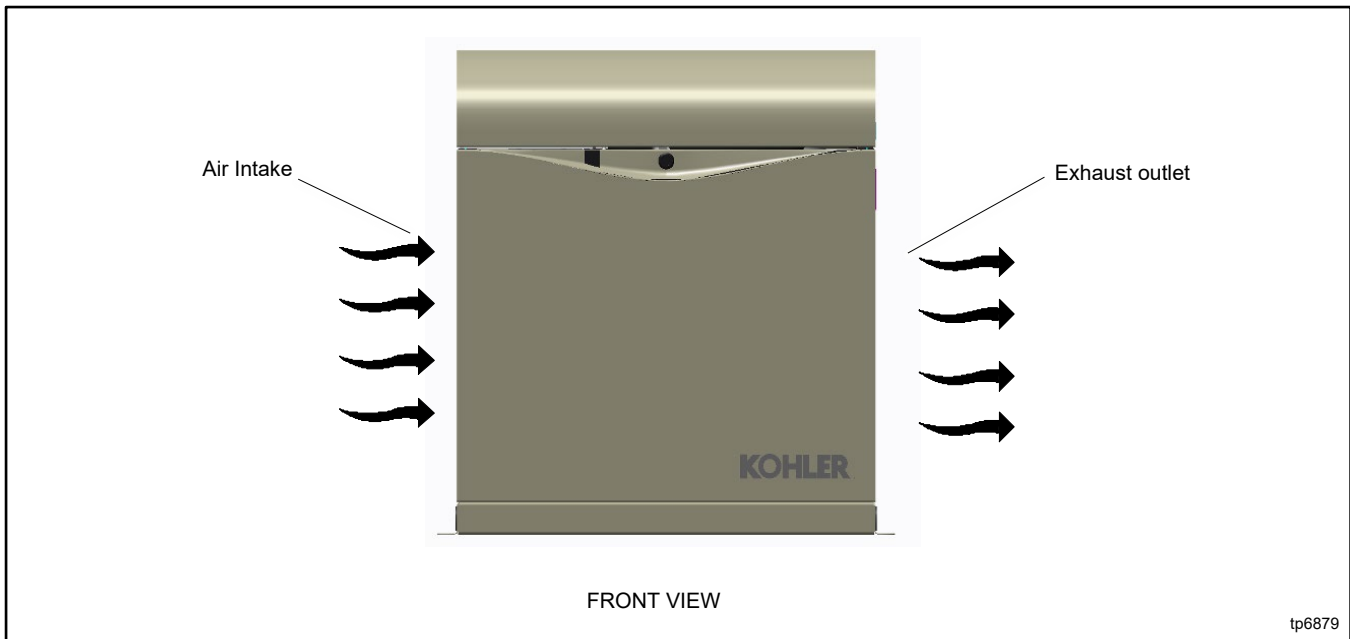

Figure 6 Cooling Air Intake and Exhaust

## 1.5 Dimension Drawings

See the dimension drawings in the Drawings and Diagrams section for the generator set dimensions, fuel and electric inlet locations, and recommended clearance.

## 1.6 Access the Air Intake Area

The battery, fuel system, and electrical connections are located in the air intake area. Raise the roof and remove the enclosure panel to access the air intake area during installation as described below.

**Note:**

Ensure that the battery is positioned toward the front of the generator so it does not block the alternator air intake vent. See Figure 7.

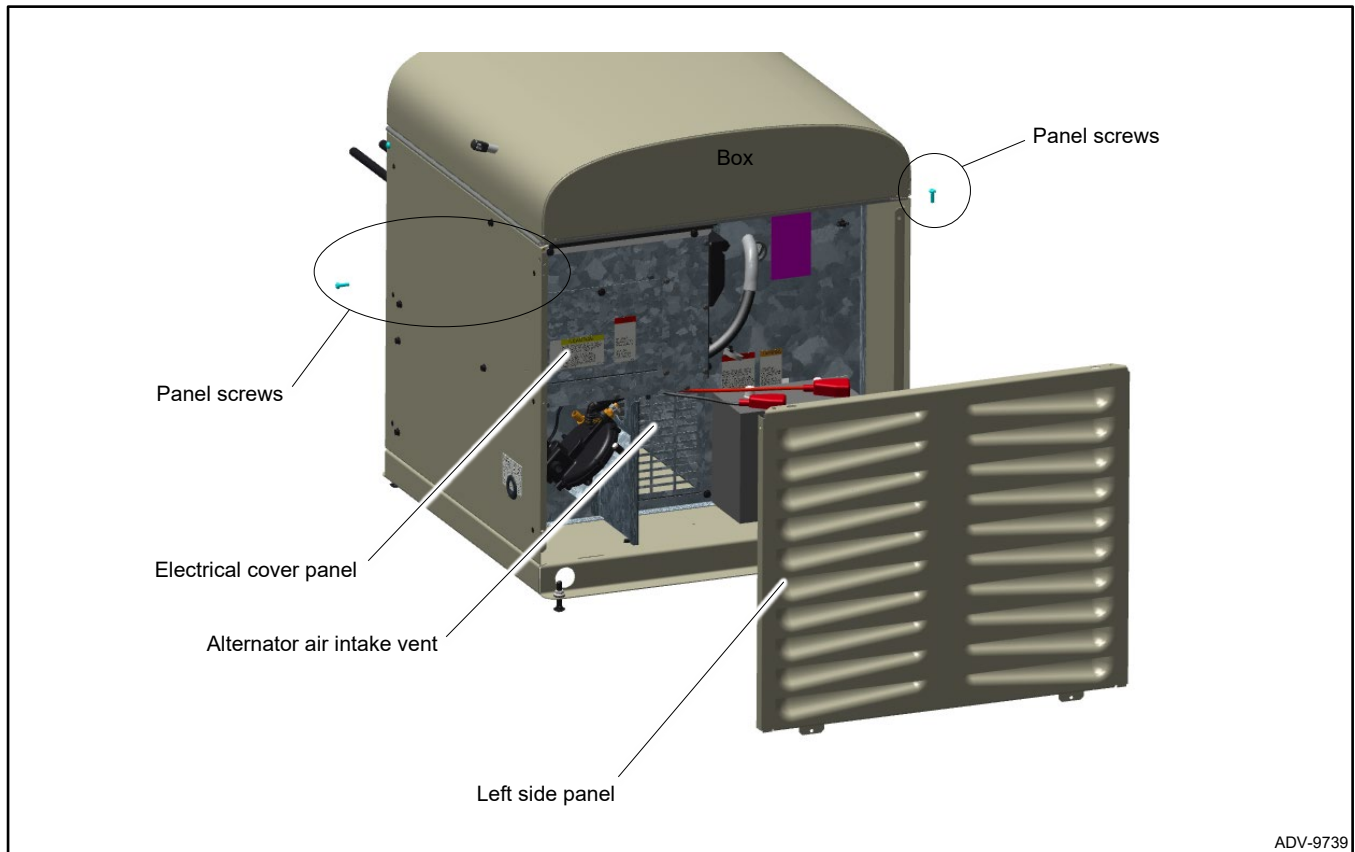

1. Remove panel screws and remove the panel. Pull the panel up and off. See Figure 7.
2. To make the electrical connections, you will also need to remove the cover panel over the terminal block.
3. Reinstall the panels after all electrical connections are complete and the battery is installed and connected.



ADV-9739

Figure 7 Remove Left Panel

## 1.7 Fuel Requirements

 <b>WARNING</b>	<p><b>Explosive fuel vapors.</b>  <b>Can cause severe injury or death.</b></p> <p>Use extreme care when handling, storing, and using fuels.</p>
 	

**The fuel system. Explosive fuel vapors can cause severe injury or death.** Vaporized fuels are highly explosive. Use extreme care when handling and storing fuels. Store fuels in a well-ventilated area away from spark-producing equipment and out of the reach of children. Never add fuel to the tank while the engine is running because spilled fuel may ignite on contact with hot parts or from sparks. Do not smoke or permit flames or sparks to occur near sources of spilled fuel or fuel vapors. Keep the fuel lines and connections tight and in good condition. Do not replace flexible fuel lines with rigid lines. Use flexible sections to avoid fuel line breakage caused by vibration. Do not operate the generator set in the presence of fuel leaks, fuel accumulation, or sparks. Repair fuel systems before resuming generator set operation.

**Gas fuel leaks. Explosive fuel vapors can cause severe injury or death.** Fuel leakage can cause an explosion. Check the LPG vapor or natural gas fuel system for leakage by using a soap and water solution with the fuel system test pressurized to 6–8 ounces per square inch (10–14 inches water column). Do not use a soap solution containing either ammonia or chlorine because both prevent bubble formation. A successful test depends on the ability of the solution to bubble.

**Explosive fuel vapors can cause severe injury or death.** Take additional precautions when using the following fuels:

**Propane (LPG)**—Adequate ventilation is mandatory. Because propane is heavier than air, install propane gas detectors low in a room. Inspect the detectors per the manufacturer’s instructions.

**Natural Gas**—Adequate ventilation is mandatory. Because natural gas rises, install natural gas detectors high in a room. Inspect the detectors per the manufacturer’s instructions.

The generator set operates using natural gas or LPG fuel. The generator set is EPA-certified for both natural gas and LPG fuels. The fuel system installation must comply with applicable national, state, and local codes.

### 1.7.1 Fuel Supply

Because of variable climates and geographical considerations, contact the local fuel supplier for fuel system planning and installation. Figure 8 lists the recommended fuel ratings and other fuel supply information for natural gas and LPG fuels.

Fuel type	Natural Gas	LPG
Fuel supply inlet	1/2 NPT	
Fuel supply pressure, kPa (in. H <sub>2</sub> O)	0.87-2.7 (3.5-11)	1.7-2.7 (7-11)
Fuel flow rate, maximum, Btu/hr.:		
8RESV(L)	136,000	147,500
10RESV(L)	179,000	222,500
12RESV(L)	216,000	257,500
<b>Nominal Fuel Rating, Btu/ft.<sup>3</sup></b>		
Natural gas	1000	
LPG	2500	

Figure 8 Fuel Supply

Verify that the output pressure from the primary gas utility pressure regulator is as shown in Figure 8 and that the utility gas meter flow rate is sufficient to supply the generator set at rated load plus all other gas-consuming appliances. For LPG tanks, verify that the output pressure is as shown in Figure 8. See the Fuel Consumption figure for fuel consumption. Contact the fuel supplier for flow rate information or a gas meter upgrade, if necessary.

### 1.7.2 Fuel Pipe Size

Ensure that the fuel pipe size and length meet the specifications in Figure 9. Measure the pipe length from the primary gas pressure regulator to the pipe connection on the generator set fuel inlet. Add 2.4 m (8 ft.) to the measured length for each 90 degree elbow. Compare the total pipe length with the chart in Figure 9 to find the required pipe size.

Contact local LPG provider for LPG installation information.

Minimum Gas Pipe Size Recommendation, in. NPT						
Pipe Length, m (ft.)	8RESV(L)		10RESV(L)		12RESV(L)	
	Natural Gas (136,000 Btu/hr.)	LPG (147,500 Btu/hr.)	Natural Gas (179,000 Btu/hr.)	LPG (222,500 Btu/hr.)	Natural Gas (216,000 Btu/hr.)	LPG (257,500 Btu/hr.)
8 (25)	3/4	1/2	3/4	3/4	3/4	3/4
15 (50)	3/4	3/4	1	3/4	1	1
30 (100)	1	3/4	1	1	1 1/4	1
46 (150)	1	1	1 1/4	1	1 1/4	1 1/4
61 (200)	1 1/4	1	1 1/4	1 1/4	1 1/4	1 1/4

Figure 9 Fuel Pipe Size Recommendations

### 1.7.3 Connecting the Fuel Supply

The dimension drawing in the Drawings and Diagrams section shows the location of the fuel inlet connection. Have the fuel supplier install rigid gas piping and a manual fuel shut-off valve. The fuel supply line should line up with the generator set fuel inlet and end about 12 inches away to allow connection with a section of flexible fuel line. Use flexible sections to prevent fuel line breakage caused by vibration.

**Note:**

Do not bend the flexible fuel line to make up for misalignment of the fuel supply line and the generator set fuel inlet.

Apply pipe sealant that is approved for fuel connections. Hold the fuel solenoid valve with a wrench when tightening the fuel connections.

**Note:**

Do not hold the fuel solenoid valve coil when tightening the fuel connections. See Figure 10 and Figure 11 for the recommended wrench locations.

Open the manual fuel valves and test all fuel connections using soapy water. If a leak is found, close the fuel valves, clean the fittings, and apply fresh sealant. Check for fuel leaks again with the generator set running.

Protect all fuel lines from machinery or equipment contact, adverse weather conditions, and environmental damage.

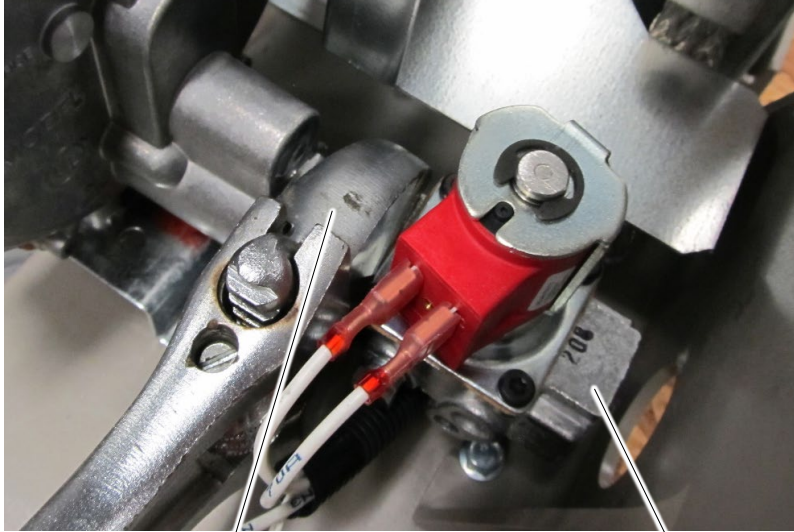

Hold valve with wrench on flats of valve body

Alternate wrench location

**Note:**

Do NOT hold the valve coil when tightening connections.

Figure 10 Holding Fuel Valve to Tighten Fuel Connections (Original Fuel System Shown)

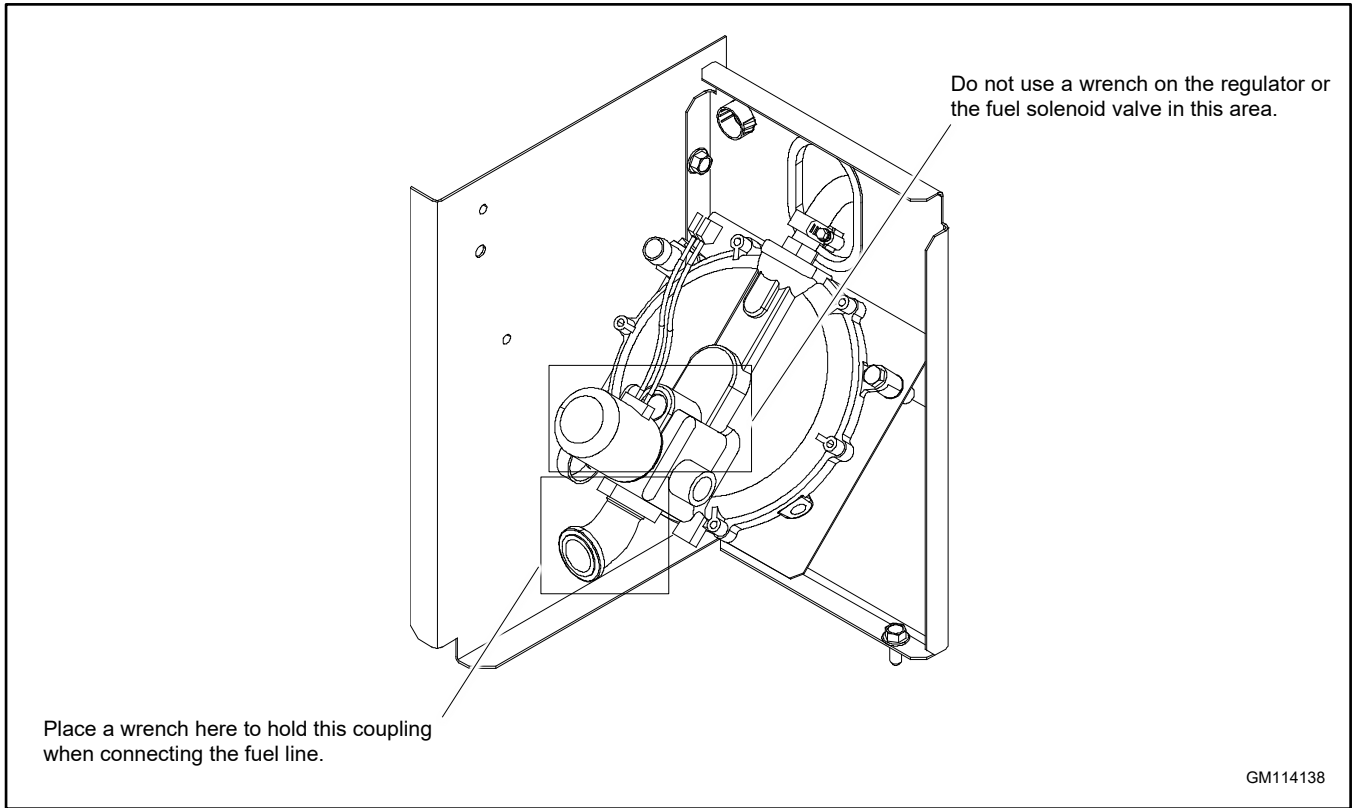

Figure 11 Holding Fuel Pipe to Tighten Fuel Connections (Revised Fuel System Shown)

Fuel Type	% Load	Fuel Consumption, m <sup>3</sup> /hr. (cfh)		
		8RESV(L)	10RESV(L)	12RESV(L)
		60 Hz	60 Hz	60 Hz
Natural Gas	100%	3.9 (136)	5.1 (179)	6.1 (216)
	75%	2.7 (95)	4.1 (145)	4.5 (160)
	50%	2.0 (69)	3.4 (120)	3.6 (128)
	25%	1.5 (53)	2.7 (97)	2.8 (99)
LPG	100%	1.7 (59)	2.5 (89)	2.9 (103)
	75%	1.3 (45)	2.0 (69)	2.2 (76)
	50%	1.0 (36)	1.5 (52)	1.6 (57)
	25%	0.75 (26)	1.1 (39)	1.2 (42)
LPG conversion factors:		Nominal fuel rating:		
8.58 ft. <sup>3</sup> = 1 lb.		Natural gas: 37 MJ/m <sup>3</sup> (1000 Btu/ft. <sup>3</sup> )		
0.535 m <sup>3</sup> = 1 kg		LPG: 93 MJ/m <sup>3</sup> (2500 Btu/ft. <sup>3</sup> )		
36.39 ft. <sup>3</sup> = 1 gal.				

Figure 12 Fuel Consumption

## 1.8 Fuel Conversion

The multi-fuel system allows conversion from natural gas (NG) to LPG (or vice-versa) in the field while maintaining emissions-standard compliance. A trained technician or an authorized distributor/dealer can convert the fuel system.

A revised fuel system was implemented in February, 2021. The fuel system can be identified by comparing the regulator and solenoid valve with the illustrations in the following sections.



The original fuel system uses a fuel selector valve. See the Fuel Conversion, Original Fuel System section for illustrations and instructions to convert the fuel on generator sets with the original design.

The revised fuel system uses fuel jet fittings to control the fuel flow for natural gas (NG) or LPG fuels. The revised system uses a fuel regulator with an integral fuel solenoid valve. See the Fuel Conversion, Revised Fuel System section for illustrations and instructions to convert the fuel on generator sets with the revised fuel system.



### Rating

Converting the fuel will change the generator set rating. See the generator set specification sheet for ratings with natural gas and LPG. When converting to LPG from factory settings, order a new nameplate with the updated rating and fuel information from an authorized distributor/dealer, if necessary. Provide the following information from the original nameplate:

- Model Number
- Spec Number
- Serial Number
- Fuel (original and new)
- kW
- kVA
- Amps
- Volts
- Hz

 <b>WARNING</b>	<b>Accidental starting. Can cause severe injury or death.</b> Disconnect the battery cables before working on the generator set. Remove the negative (-) lead first when disconnecting the battery. Reconnect the negative (-) lead last when reconnecting the battery.
	

**Disabling the generator set. Accidental starting can cause severe injury or death.** Before working on the generator set or equipment connected to the set, disable the generator set as follows: (1) Press the generator set off/reset button to shut down the generator set. (2) Disconnect the power to the battery charger, if equipped. (3) Remove the battery cables, negative (-) lead first. Reconnect the negative (-) lead last when reconnecting the battery. Follow these precautions to prevent the starting of the generator set by the remote start/stop switch.

 <b>WARNING</b>	<b>Explosive fuel vapors. Can cause severe injury or death.</b> Use extreme care when handling, storing, and using fuels.
	

## 1.8.1 Fuel Conversion, Original Fuel System

### Fuel Conversion Procedure

The fuel selector valve allows field-conversion between natural gas (NG) and LPG. The valve is factory-set to comply with applicable emission standards and to provide the best possible hot and cold starting.

**Note:**

Do not adjust the factory-set screw on the selector valve. Adjusting the screw may violate federal and state laws. See Figure 17.

Use the following procedure to convert the fuel system. The procedure includes removing the side panel, removing the cap from the fuel selector valve, and making the fuel selection.

See Figure 13 for fuel system components.

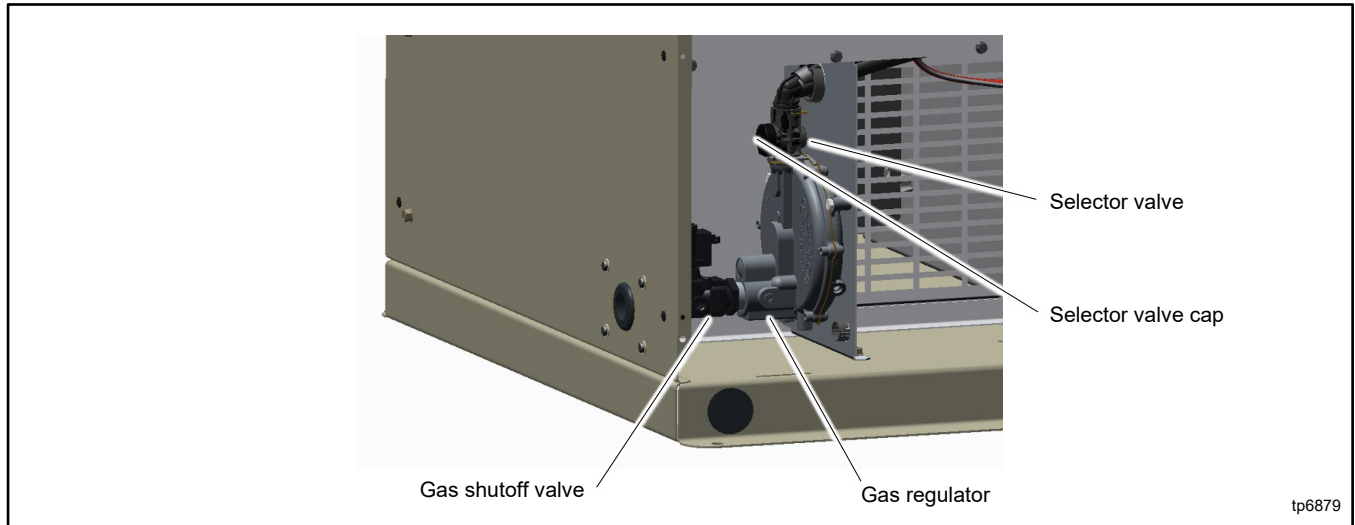

Figure 13 Fuel System

1. Press the OFF button on the generator set controller.
2. Disconnect the power to the battery charger.
3. Disconnect the generator set engine starting battery, negative (-) lead first.
4. Turn off the fuel supply.
5. Remove panel screws and remove the left side louvered panel. Figure 14.

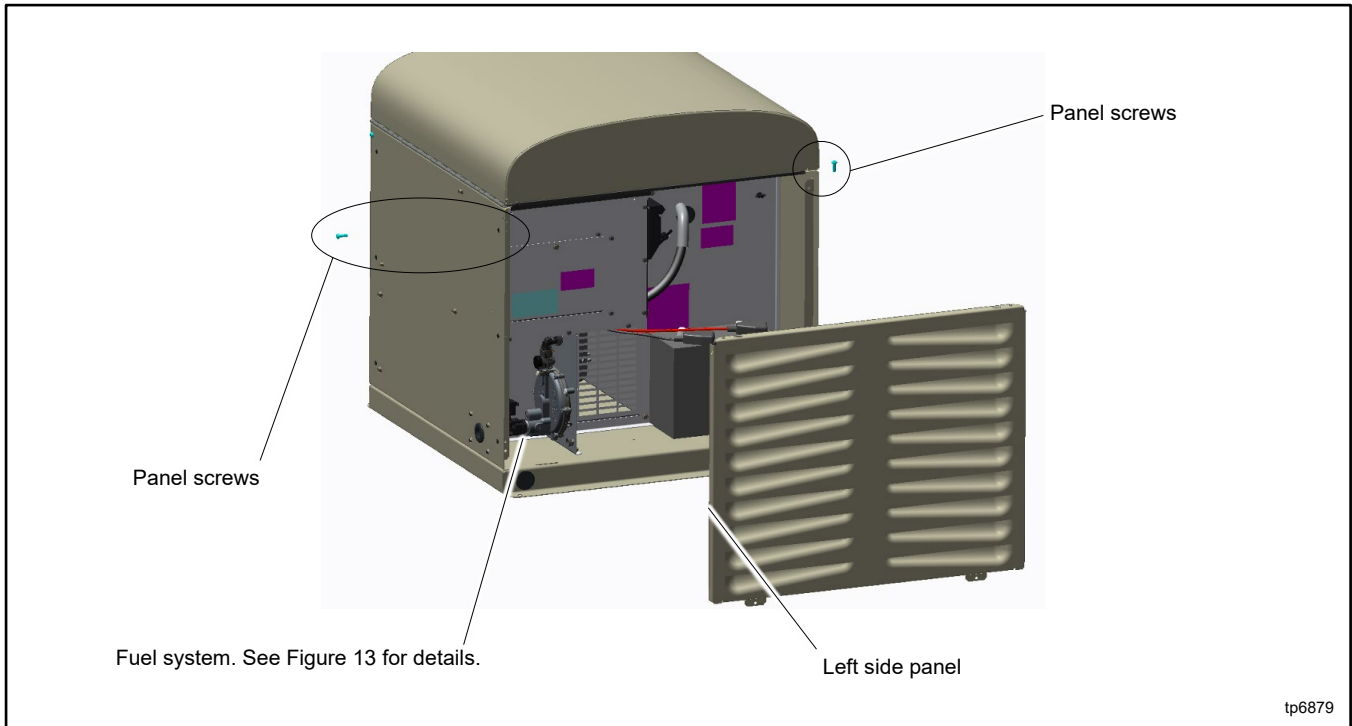

Figure 14 Remove Left Panel

6. Remove the cap from the fuel selector valve. See Figure 15. Insert a flat head screwdriver under the lip of the cap and push it upwards. Keep the cap close by as it is needed to switch fuels in the next step.

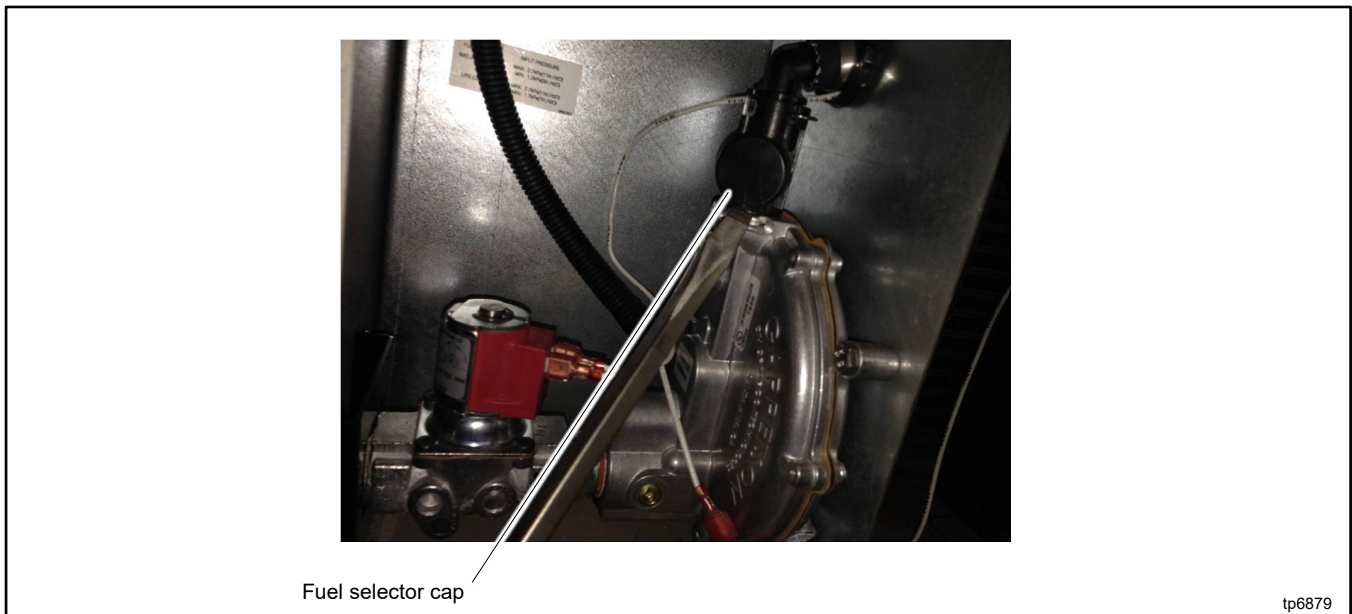

Figure 15 Cap Removal

7. See Figure 16. Use the cap in the orientation shown to turn the selector valve to NG or LP. See Figure 17 for valve positions.



Figure 16 Fuel Selection

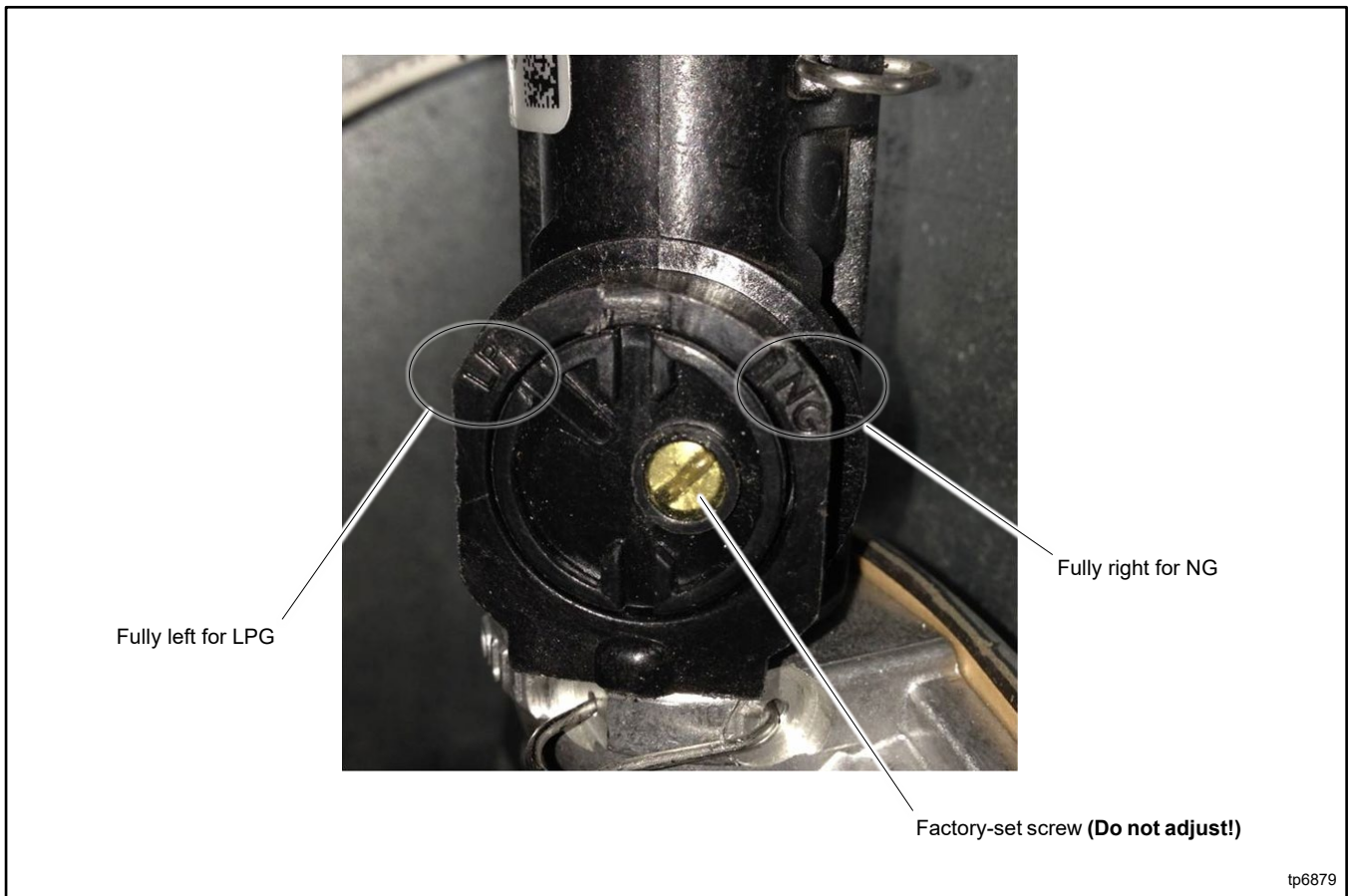

Figure 17 Valve Positions

8. Replace the cap.
9. Connect and turn on the fuel supply (ensure that the fuel supply matches the fuel setting).
10. Reconnect the generator set engine starting battery leads, negative (-) lead last.
11. Reconnect power to the battery charger.
12. Reassemble the left side panel.
13. Start the generator set by pressing the RUN button on the generator set controller.
14. Check for leaks using a gas leak detector.
15. Run the generator set and check the operation.
16. Press the OFF button to shut down the generator set.

## 1.8.2 Fuel Conversion, Revised Fuel System

### Fuel Conversion Procedure

For natural gas (NG) and LPG, fuel jet fittings are used in the fuel line. The fittings are labelled for NG and LPG. See Figure 18.

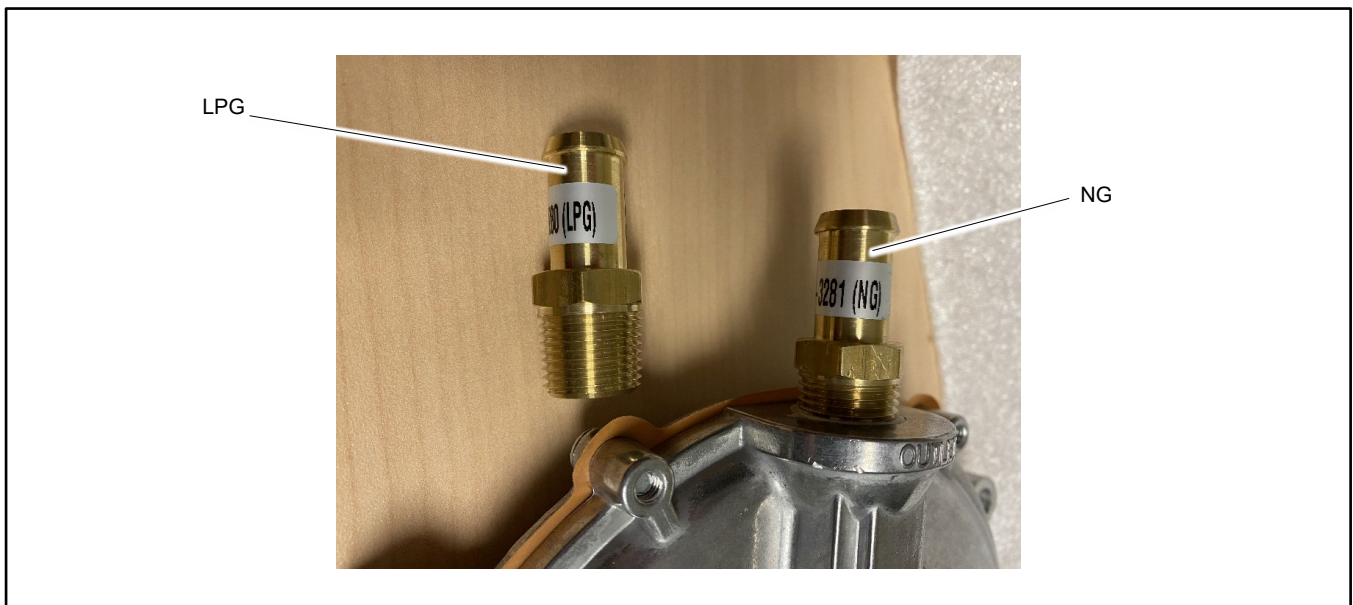

Figure 18 NG and LPG Fuel Jets

1. Press the OFF button on the generator set controller.
2. Disconnect the power to the battery charger.
3. Disconnect the generator set engine starting battery, negative (-) lead first.
4. Turn off the fuel supply.
5. Remove the hose clamp and fuel hose from the hose fitting. See Figure 19.

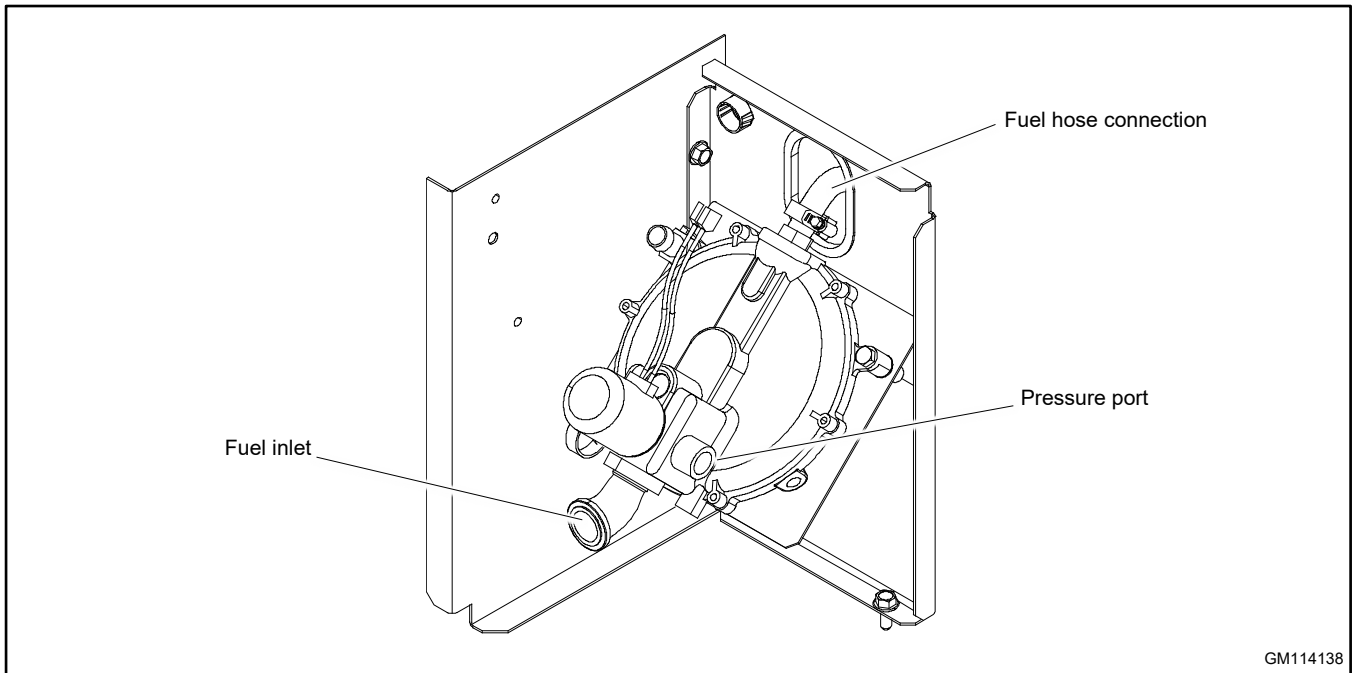

Figure 19 Revised Fuel System

6. Remove the NG fuel jet/hose fitting. See Figure 20.

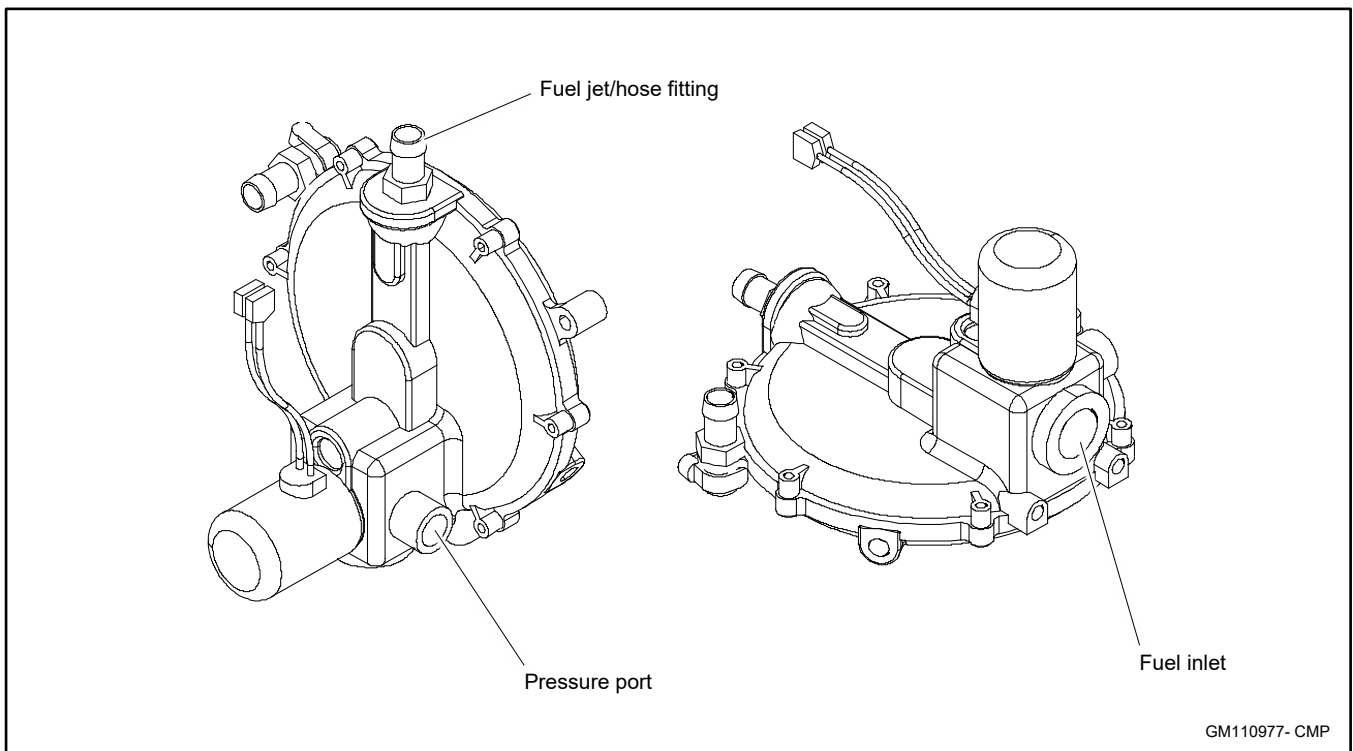

Figure 20 Fuel Regulator



7. Insert the LPG fitting into the regulator outlet opening. Use a wrench to tighten the fitting until it is snug.
8. Slide the hose onto the hose fitting and secure it with the clamp.
9. Connect and turn on the fuel supply (Ensure that the fuel supply matches the fuel selection).
10. Reconnect the generator set engine starting battery leads, negative (-) lead last.
11. Reconnect power to the battery charger.

12. Change the Fuel Type Setting on the RDC2 controller in the Genset System menu. See the Operation Manual for instructions to change settings on the controller.
13. Start the generator set by pressing the RUN button on the generator set controller.
14. Check for leaks using a gas leak detector.
15. Run the generator set and check the operation.
16. Press the OFF button to shut down the generator set.

A pressure port is provided on the fuel regulator. See Figure 19. Follow these steps to check the fuel pressure at the regulator, if necessary.

1. Remove the plug from the fuel pressure port.
2. Connect a manometer capable of measuring low pressures (3-11 inches water column) to the pressure port.
3. When finished, replace the plug in the pressure port and check for leaks.

## 1.9 Electrical Connections

 <b>DANGER</b>	<p><b>Hazardous voltage.</b>  <b>Will cause severe injury or death.</b></p> <p>This equipment must be installed and serviced by qualified electrical personnel.</p>
	

**Grounding electrical equipment. Hazardous voltage will cause severe injury or death.** Electrocutation is possible whenever electricity is present. Ensure you comply with all applicable codes and standards. Electrically ground the generator set, transfer switch, and related equipment and electrical circuits. Turn off the main circuit breakers of all power sources before servicing the equipment. Never contact electrical leads or appliances when standing in water or on wet ground because these conditions increase the risk of electrocution.

**Electrical backfeed to the utility. Hazardous backfeed voltage can cause severe injury or death.** Install a transfer switch in standby power installations to prevent the connection of standby and other sources of power. Electrical backfeed into a utility electrical system can cause severe injury or death to utility personnel working on power lines.

### NOTICE

**Canadian installations only.** For standby service connect the output of the generator set to a suitably rated transfer switch in accordance with Canadian Electrical Code, Part 1.

Have an authorized distributor/dealer or a licensed electrician make the following electrical connections. The electrical installation must comply with the National Electrical Code® (NEC) class 1 wire designation and all applicable local codes. Canadian installations must comply with the Canadian Electrical Code (CEC) and applicable local codes.

**AC circuit protection.** All AC circuits must include circuit breaker or fuse protection. The circuit breaker must be rated for a maximum of 125% of the rated generator set output current. The circuit breaker must open all ungrounded connectors. The generator set is equipped with a factory-installed circuit breaker.

For customer-supplied wiring, select the wire temperature rating in Figure 21 based upon the following criteria:

- Select row 1, 2, 3, or 4 if the circuit rating is 110 amperes or less or requires #1 AWG (42.4 mm<sup>2</sup>) or smaller conductors.
- Select row 3 or 4 if the circuit rating is greater than 110 amperes or requires #1 AWG (42.4 mm<sup>2</sup>) or larger conductors.

Row	Temp. Rating	Copper (Cu) Only	Cu/Aluminum (Al) Combinations	Al Only
1	60°C (140°F) or 75°C (167°F)	Use No. * AWG, 60°C wire or use No. * AWG, 75°C wire	Use 60°C wire, either No. * AWG Cu, or No. * AWG Al or use 75°C wire, either No. * AWG Cu or No. * AWG Al	Use 60°C wire, No. * AWG or use 75°C wire, No. * AWG
2	60°C (140°F)	Use No. * AWG, 60°C wire	Use 60°C wire, either No. * AWG Cu or No. * AWG Al	Use 60°C wire, No. * AWG
3	75°C (167°F)	Use No. *† AWG, 75°C wire	Use 75°C wire, either No. *† AWG Cu or No. *† AWG Al	Use 75°C wire, No.*† AWG
4	90°C (194°F)	Use No. *† AWG, 90°C wire	Use 90°C wire, either No. *† AWG Cu or No. *† AWG Al	Use 90°C wire, No.*† AWG
* The wire size for 60°C (140°F) wire is not required to be included in the marking. If included, the wire size is based on ampacities for the wire given in Table 310-16 of the National Electrical Code®, in ANSI/NFPA 70, and on 115% of the maximum current that the circuit carries under rated conditions. The National Electrical Code® is a registered trademark of the National Fire Protection Association, Inc.				
† Use the larger of the following conductors: the same size conductor as that used for the temperature test or one selected using the guidelines in the preceding footnote.				

Figure 21 Terminal Markings for Various Temperature Ratings and Conductors

### 1.9.1 Grounding

Ground the generator set. The grounding method must comply with NEC and local codes. Connect the ground to the generator set ground lug, terminal GND inside the controller compartment.

The requirement for having a bonded (grounded) neutral or ungrounded neutral is determined by the type of installation. At installation, the neutral can be grounded at the generator set or lifted from the ground stud and isolated if the installation requires an ungrounded neutral connection at the generator. The generator set will operate properly with the neutral either bonded to ground or isolated from ground at the generator.

**Note:**

When shipped, the generator neutral is not bonded (grounded) to the generator ground.

Various regulations and site configurations including the National Electrical Code (NEC), local codes, and the type of transfer switch used in the application determine the grounding of the neutral at the generator. NEC Section 250 is one example that has a very good explanation of the neutral grounding requirements for generators.

The National Electrical Code® is a registered trademark of the National Fire Protection Association, Inc.

### 1.9.2 Electrical Lead Entry

Drill or punch holes in the enclosure for the electrical conduit in the locations shown in Figure 22.

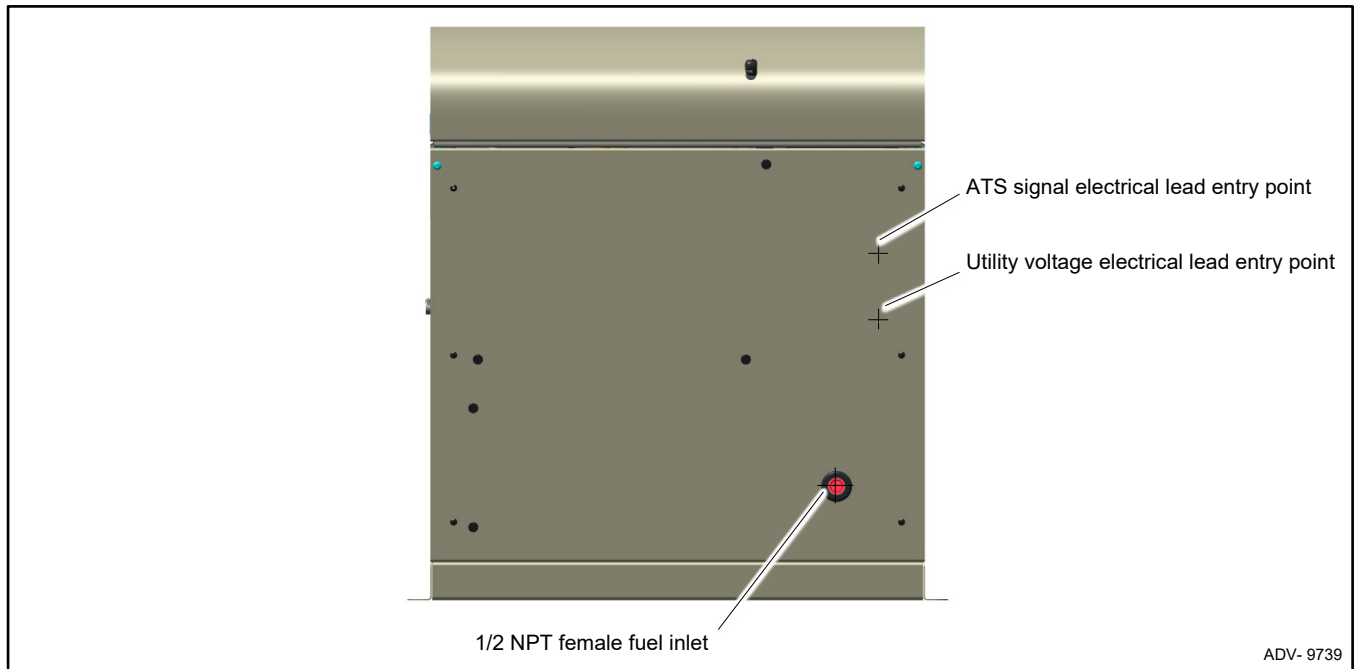

Figure 22 Electrical Lead Entry Locations

### 1.9.3 Field-Connection Terminal Block

The generator set is equipped with a field-connection terminal block located in the air inlet area inside the junction box. Leads have been factory-installed from the junction box to the terminal block for easy field wiring.

See Figure 23 for terminal block location. Remove the cover panel for access to the field connections.

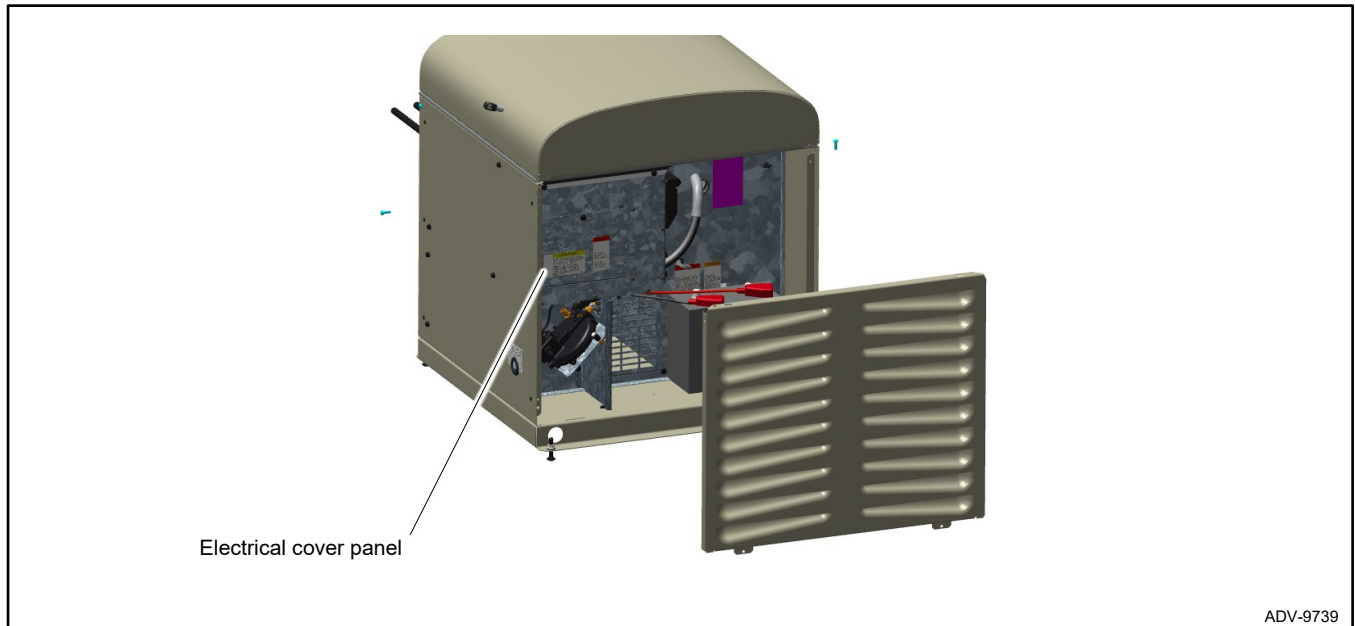

Figure 23 Field-Connection Terminal Block Location

See Figure 24 for terminal block details. Refer to the terminal block decal for connections and cable sizes. Also see the wiring diagram in the Drawings and Diagrams section.

Route AC leads through flexible conduit. Ensure that the leads and conduit do not interfere with the operation of the generator set or obstruct the service areas. Route low-voltage communication leads through separate conduit.

### Procedure

1. Drill holes for the conduit fittings. See the Electrical Lead Entry Locations figure for the recommended electrical inlet locations. Feed the cables through the openings.
2. Connect the leads from the transfer switch emergency source lugs to the L1 and L2 connections on the generator set terminal block.
3. Connect the neutral (L0) and ground (GRD) leads from the ATS and the main panel to the corresponding connection points on the terminal block. See the Grounding section.
4. Connect utility power leads to the terminal block connections labelled UTILITY. Connect to a circuit that is supplied by the utility source and backed up by the generator. See the AC Power Supply section for more information about the utility power requirement.
5. For connection of optional transfer switches, the programmable interface module (PIM), and/or a load shed kit, see the ATS and Accessory Connections section.
6. To connect the KOHLER Energy Management System to your generator, run Ethernet cable from the generator set to the customer's router or modem.
  - a. Route the Ethernet cable with other low-voltage signal wiring (for example, the RBUS communication leads or engine start leads to the transfer switch), in separate conduit from the AC load leads. If the Ethernet cable is longer than 100 meters (328 ft.), use a repeater or switch.
  - b. Test the internet connection for the generator by connecting a laptop to the Ethernet cable.
    - (1) Turn OFF any wireless connections to the laptop.
    - (2) Connect the Ethernet cable to the laptop. Connect the other end of the Ethernet cable to the customer's router or modem.
    - (3) Verify the Internet connection by opening your web browser and going to [kohlergenerators.com](http://kohlergenerators.com) or any known website.
    - (4) Disconnect the Ethernet cable from the laptop.
  - c. Use an RJ45 inline coupler to connect the Ethernet cable to the cable in the customer connection box. See Figure 24. The inline coupler is included with the wireless kit.
7. When connections to the terminal block are complete, replace the cover plate.

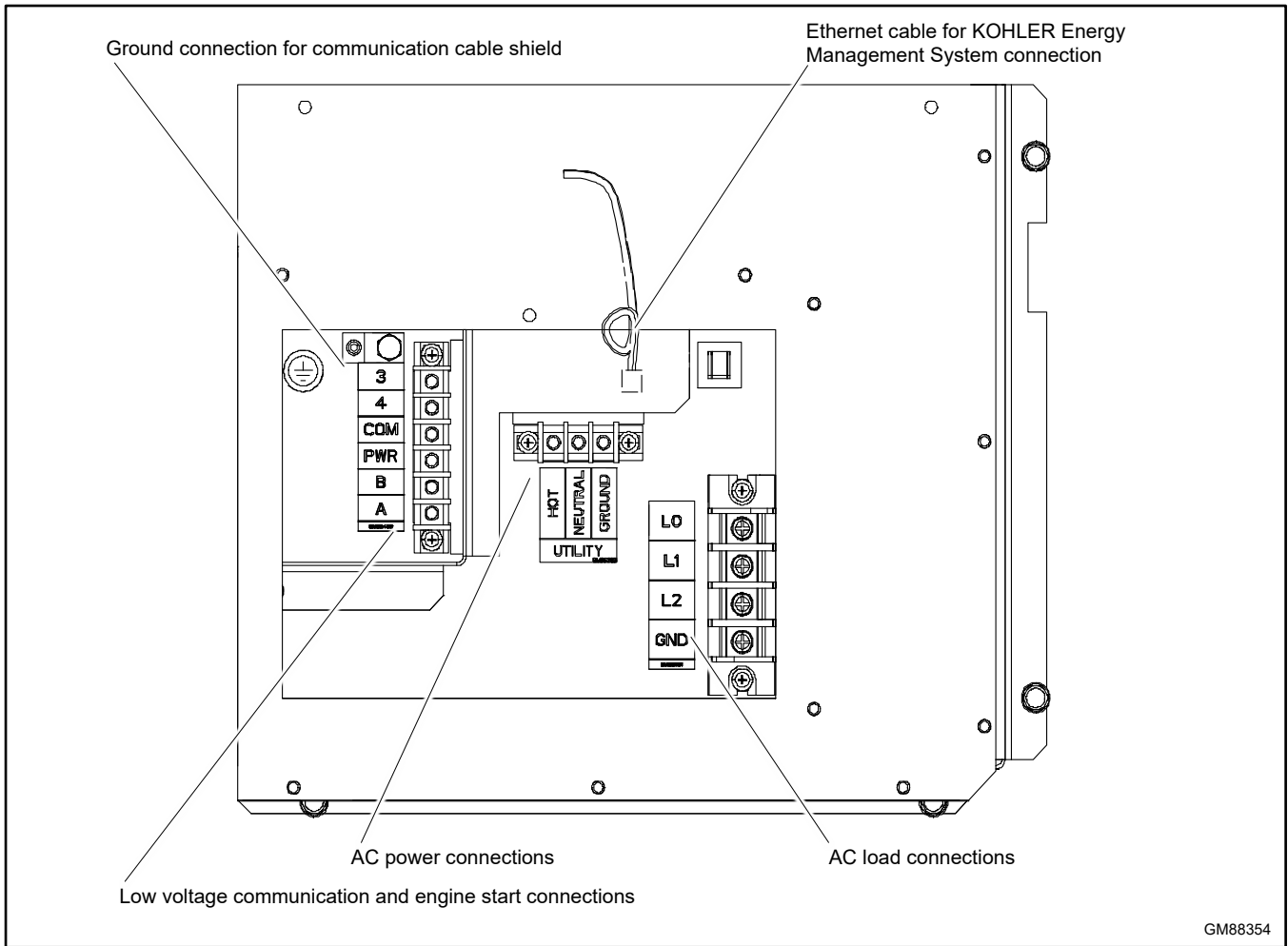

Figure 24 Electrical Connections

### 1.9.4 AC Power Supply



The installer must connect AC power for the battery charger (which is integral to the RDC2 controller) and the optional accessories shown in Figure 25. The power source must comply with state and local codes. The power to the battery charger and accessories must be backed up by the generator so that power is available at all times.

Be sure to disconnect power at the distribution panel before making the connections. Connect power leads to the utility power connection points on the terminal block. See the Field-Connection Terminal Block section and the wiring diagrams in the Drawings and Diagrams section for connection details.

Equipment	Power Requirement, Max.		
	Watts	Amps	Volts
Battery charger (standard)	50	0.4	100-250 VAC 50/60 Hz
Carburetor heater *	37	0.3	120 VAC 50/60 Hz
* Optional accessory			

Figure 25 Power Requirements

## 1.10 ATS and Accessory Connections

 <b>WARNING</b>	<b>Hazardous voltage. Backfeed to the utility system. Can cause property damage, severe injury, or death.</b>
	If the generator set is used for standby power, install an automatic transfer switch to prevent inadvertent interconnection of standby and normal sources of supply.

The following sections cover electrical connections of the automatic transfer switches and RBUS accessories, including the programmable interface module (PIM), or the load shed kit.

**Note:**

Load shed kits are not available when combined with the transfer switch supplied with models 8/10/12RESV(L).

### 1.10.1 Transfer Switch Connection

Connect the ATS or remote start/stop switch. Connect the load leads from the generator set to the Emergency source lugs on the ATS. Route low-voltage communication leads through separate conduit from the AC power and load leads. All connections must comply with applicable state and local codes.

**Note:**

Do not use the Model RRT transfer switch with the RESV or RESVL generator set.

#### Communication connections for a Model RXT transfer switch

One Model RXT transfer switch can be connected to the generator set. See Figure 26. Use shielded, twisted-pair communication cable to connect P10-1 through P10-4 on the transfer switch interface module to the generator set terminal block connections A, B, PWR, and COM.

The Model RXT transfer switch with the combined interface/load management board requires one set of RBUS connections to the generator set. However, the combined board acts as two RBUS modules: one RXT transfer switch and one load management device.

**Note:**

Connections 3 and 4 on the generator set are not used with the Model RXT transfer switch.

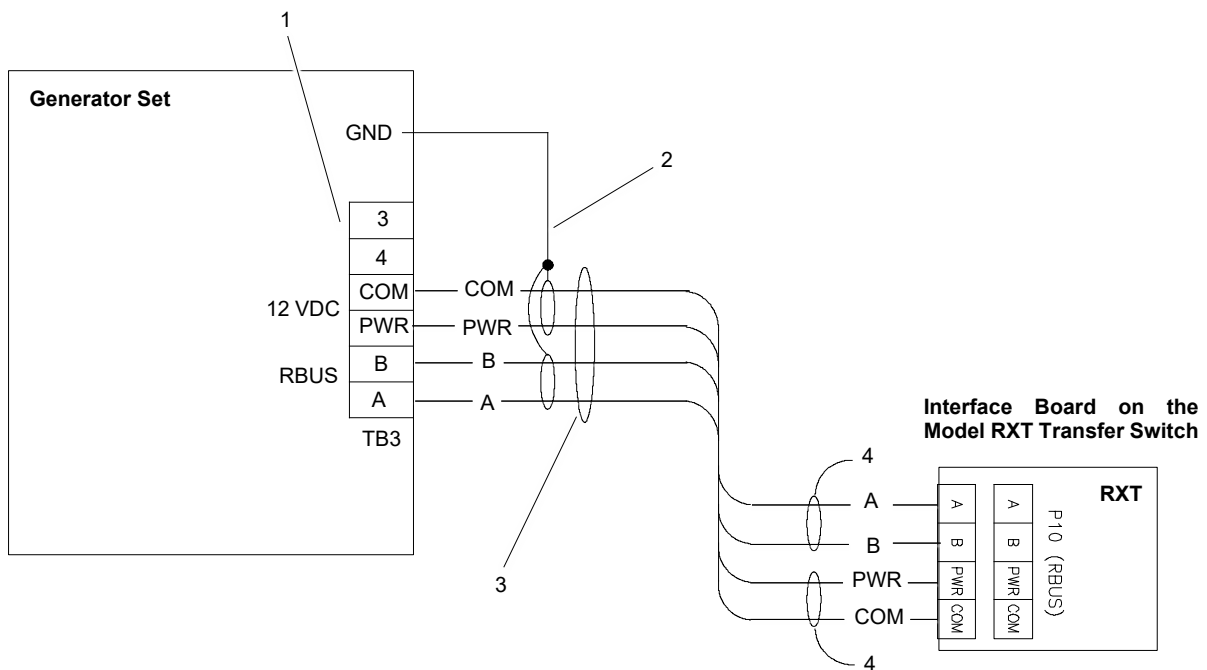

**Note:**

Generator set terminal block (TB3) connections 3 and 4 are NOT USED with the Model RXT ATS.

1. Generator set terminal block TB3. See the Dimension Drawing ADV-8774, Sheet 3 figure for location. Check the decal on the generator set for terminal block connections.
2. Connect one end of each cable shield to GROUND at the generator set.
3. Communication cable Belden #9402 or equivalent 20 AWG shielded, twisted-pair cable. See the Communication Cable Specifications section
4. Leave one end of each cable shield disconnected.

Figure 26 Model RXT Transfer Switch Communication Connection to Generator Set Terminal Block

### Engine start connection for other transfer switches or a remote start/stop switch

Connect the engine start leads from the transfer switch or remote start switch to terminals 3 and 4 on the terminal block. See Figure 27. Route the engine start leads through separate conduit from the AC power and load leads.

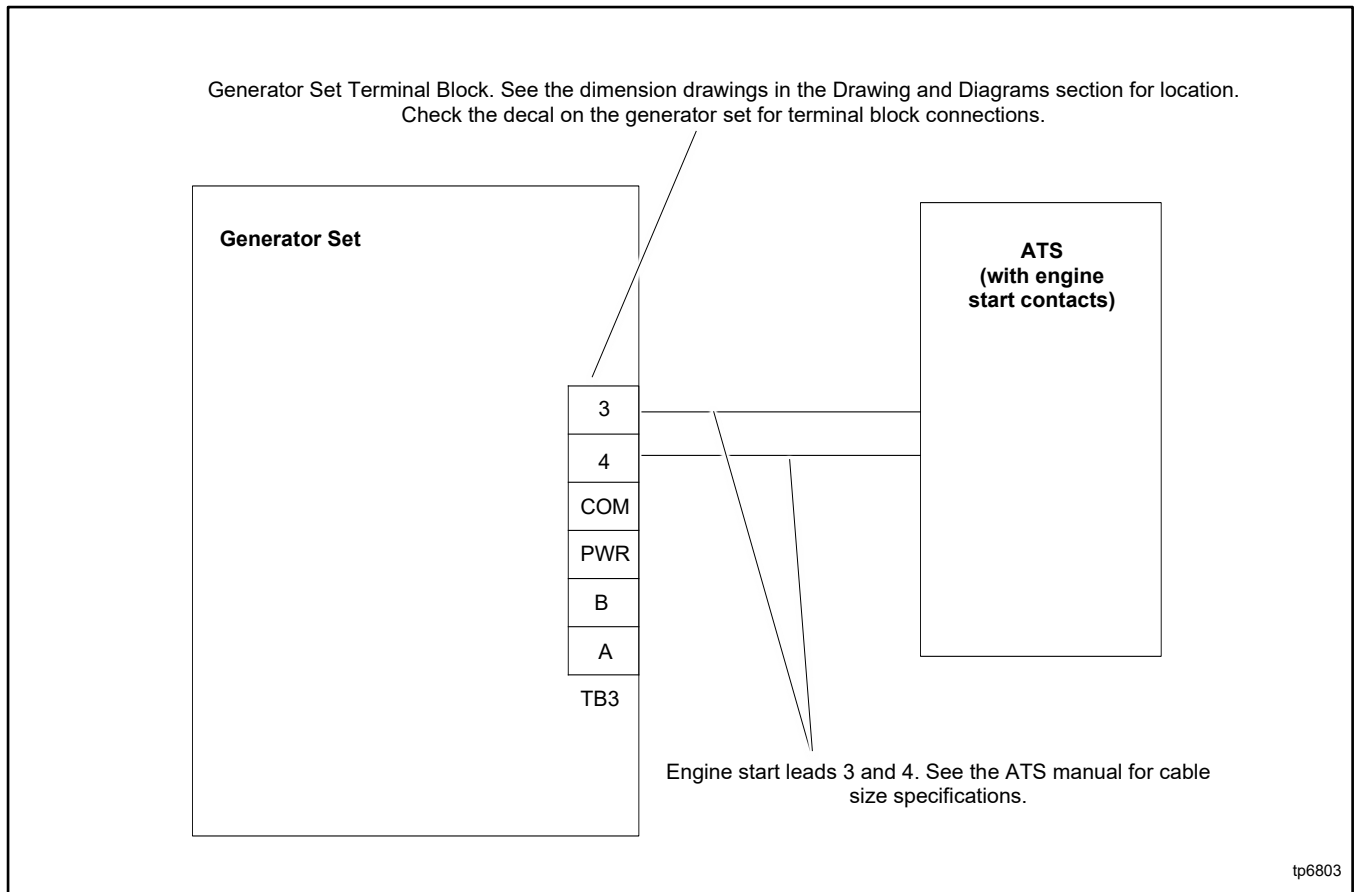

Figure 27 Engine Start Connections with Transfer Switch Models other than Model RXT

## 1.10.2 Communication Cable Specifications

### RBUS Connections A and B

For the RBUS communication connections A and B to the Model RXT transfer switch, optional PIM and/or optional load shed kit, use 20 AWG shielded, twisted-pair communication cable. Belden #9402 (two-pair) or Belden #8762 (single-pair) or equivalent cable is recommended.

For outdoor installations, including those with buried cables and/or conduit, use outdoor-rated Belden #1075A or equivalent 20 AWG shielded, twisted-pair communication cable.

### PWR and COM Connections

For the PWR and COM connections from the generator set to the RXT, PIM and/or load shed kit, use the second pair in the two-pair communication cable for short runs, or use 12-14 AWG cable for longer runs as shown in Figure 28.

The maximum cable length depends on the number of optional modules connected. A module can be a Model RXT transfer switch, a load management device, or a programmable interface module (PIM). See the Figure 28 for the maximum cable lengths for 1, 2, or 3 modules per cable run. Note the shield connections shown in the Accessory Module Communication Connection Details figure.

**Note:**

A model RXT transfer switch with combined interface/load management board acts as two RBUS modules: one RXT transfer switch and one load management device.

**Note:**

Power relay modules, if used, are not RBUS modules and do not have RBUS communication connections.

Cable Size for PWR and COM Connections	Indoor or Outdoor Installation	Maximum length per run, meters (ft.)					
		Number of Modules (ATS, PIM, or Load Shed Kit) per Run					
		1 Module		2 Modules		3 Modules	
20 AWG Belden #9402 or equivalent, two-pair	Indoor	61	(200)	31	(100)	21	(67)
20 AWG Belden #1075A or equivalent, two-pair	Outdoor	61	(200)	31	(100)	21	(67)
14 AWG *	—	152	(500)	152	(500)	122	(400)
12 AWG *	—	152	(500)	152	(500)	152	(500)
* Use 12 or 14 AWG cable for PWR and COM connections only. For RBUS connections A and B, use shielded, twisted pair communication cable specified in the Communication Cable Specifications section.							

Figure 28 Total Cable Lengths for PWR and COM Connections

### 1.10.3 System Connections with Accessory Modules

See Figure 30 through Figure 32 for connection options with accessory modules. Accessory modules can include one Model RXT transfer switch, one programmable interface module (PIM) and one load shed kit.

See the Total Cable Lengths for PWR and COM Connections figure for the maximum total cable length with 1, 2, or 3 accessory modules per cable run.

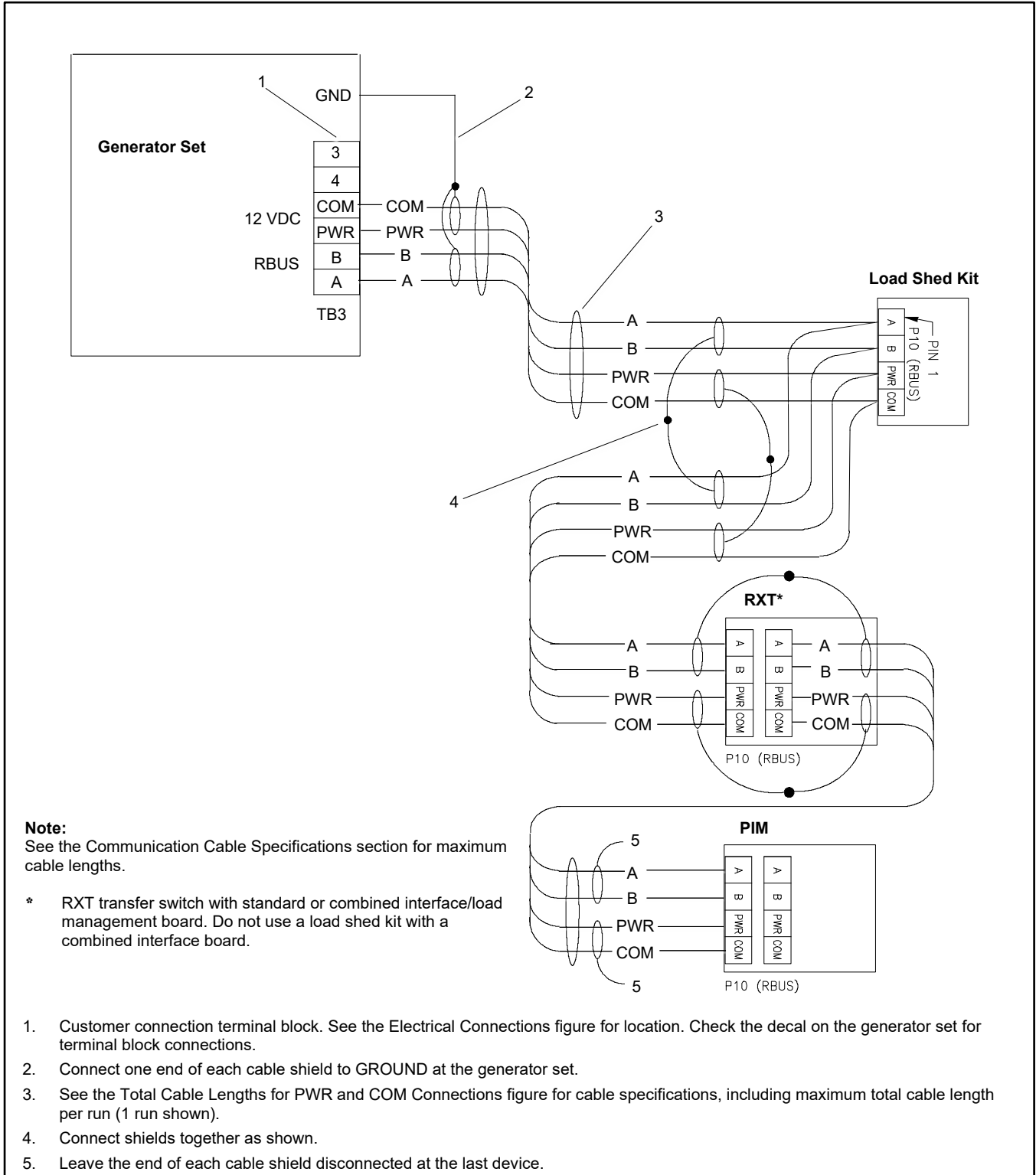
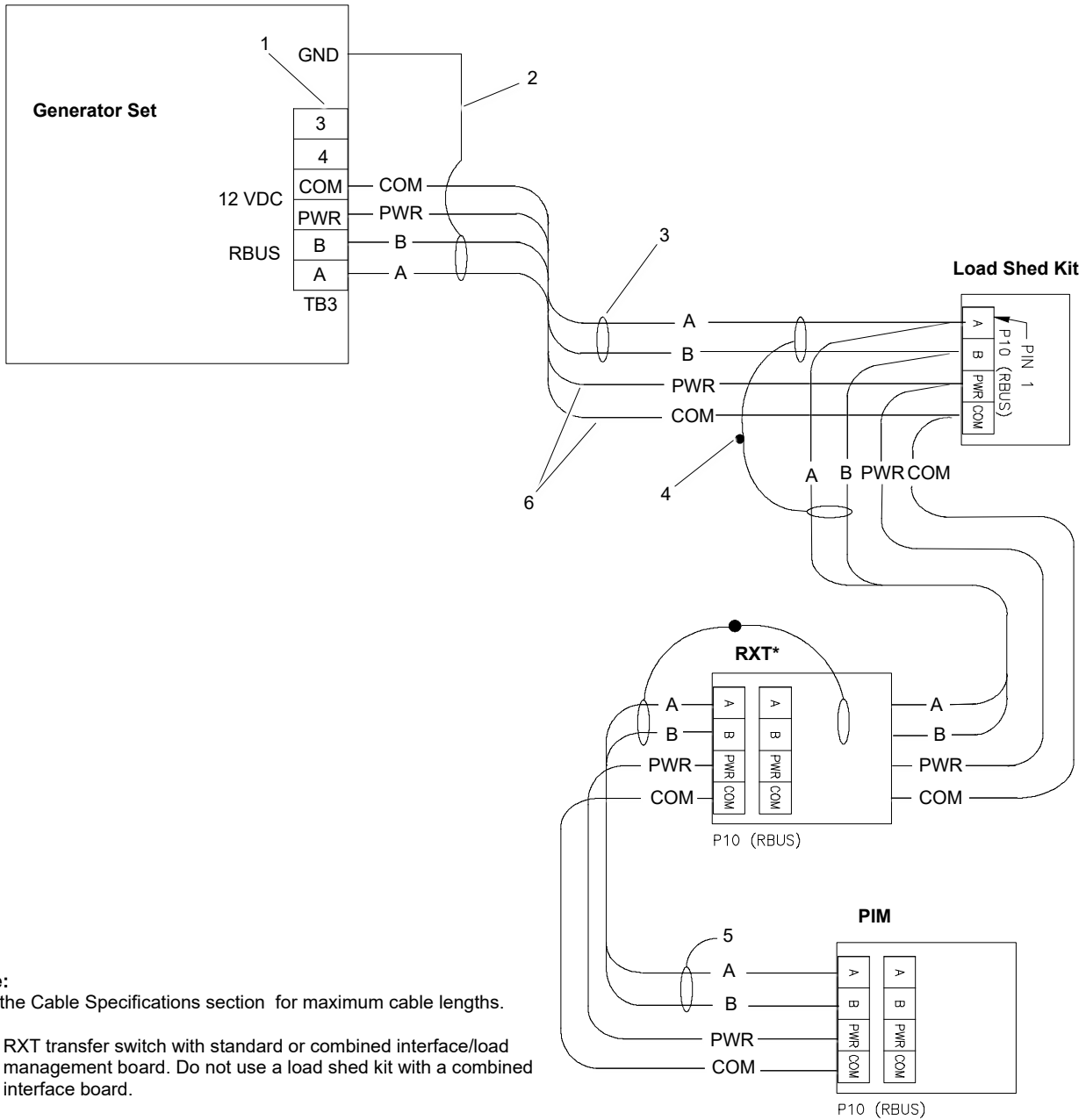

Figure 29 Accessory Module Communication Connection Details



**Note:**

See the Cable Specifications section for maximum cable lengths.

\* RXT transfer switch with standard or combined interface/load management board. Do not use a load shed kit with a combined interface board.

1. Generator set terminal block. See the Dimension Drawing ADV-8774, Sheet figure for location. Check the decal on the generator set for terminal block connections.
2. Connect one end of each cable shield to GROUND at the generator set.
3. Communication cable Belden #8762 or equivalent 20 AWG shielded, twisted-pair cable (one pair).
4. Connect shields together as shown.
5. Leave one end of each cable shield disconnected at the last device.
6. 12 AWG or 14 AWG leads for PWR and COM.

Figure 30 Accessory Module Communication Connection Details

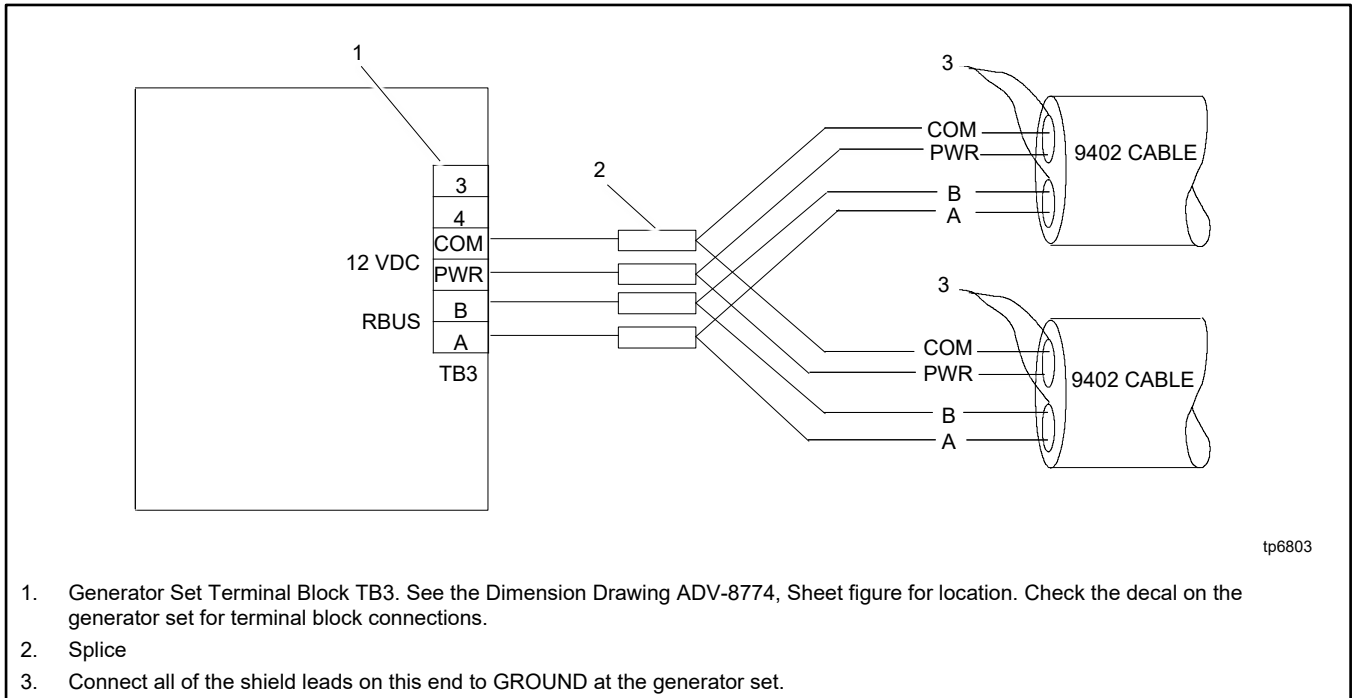

Figure 31 Multiple Connections to the Generator Set

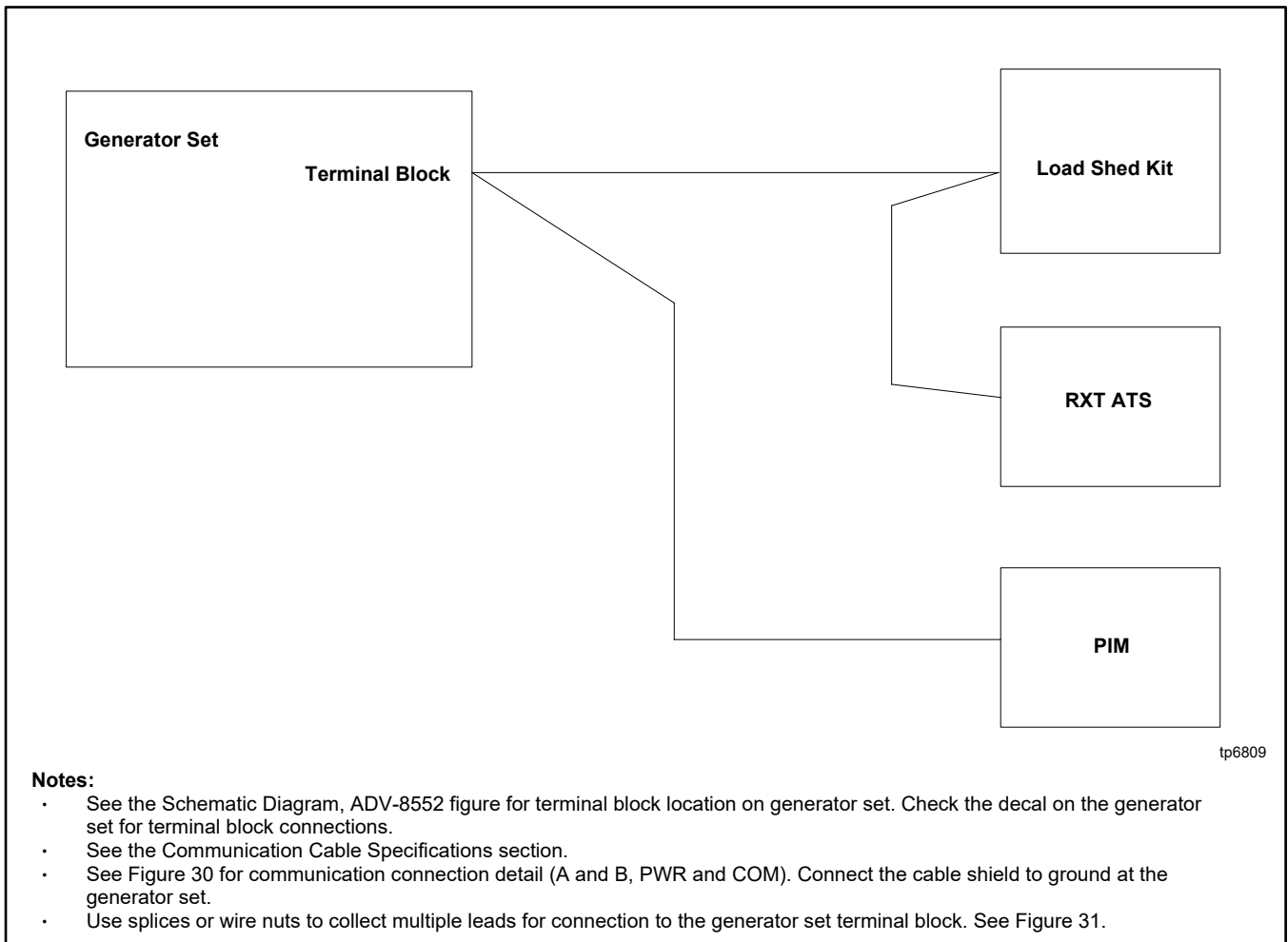





Figure 32 Accessory Module Connections (two cable runs with one and two modules shown)

## 1.11 Battery

 <b>WARNING</b>	<b>Sulfuric acid in batteries.</b> <b>Can cause severe injury or death.</b> Wear protective goggles and clothing. Battery acid may cause blindness and burn skin.
	
 <b>WARNING</b>	<b>Explosion.</b> <b>Can cause severe injury or death.</b> <b>Relays in the battery charger cause arcs or sparks.</b> Locate the battery in a well-ventilated area. Isolate the battery charger from explosive fumes.
	

**Battery electrolyte is a diluted sulfuric acid. Battery acid can cause severe injury or death.** Battery acid can cause blindness and burn skin. Always wear splashproof safety goggles, rubber gloves, and boots when servicing the battery. Do not open a sealed battery or mutilate the battery case. If battery acid splashes in the eyes or on the skin, immediately flush the affected area for 15 minutes with large quantities of clean water. Seek immediate medical aid in the case of eye contact. Never add acid to a battery after placing the battery in service, as this may result in hazardous spattering of battery acid.

**Battery acid cleanup. Battery acid can cause severe injury or death.** Battery acid is electrically conductive and corrosive. Add 500 g (1 lb.) of bicarbonate of soda (baking soda) to a container with 4 L (1 gal.) of water and mix the neutralizing solution. Pour the neutralizing solution on the spilled battery acid and continue to add the neutralizing solution to the spilled battery acid until all evidence of a chemical reaction (foaming) has ceased. Flush the resulting liquid with water and dry the area.

**Battery gases. Explosion can cause severe injury or death.** Battery gases can cause an explosion. Do not smoke or permit flames or sparks to occur near a battery at any time, particularly when it is charging. Do not dispose of a battery in a fire. To prevent burns and sparks that could cause an explosion, avoid touching the battery terminals with tools or other metal objects. Remove all jewelry before servicing the equipment. Discharge static electricity from your body before touching batteries by first touching a grounded metal surface away from the battery. To avoid sparks, do not disturb the battery charger connections while the battery is charging. Always turn the battery charger off before disconnecting the battery connections. Ventilate the compartments containing batteries to prevent accumulation of explosive gases.

**Battery short circuits. Explosion can cause severe injury or death.** Short circuits can cause bodily injury and/or equipment damage. Disconnect the battery before generator set installation or maintenance. Remove all jewelry before servicing the equipment. Use tools with insulated handles. Remove the negative (-) lead first when disconnecting the battery. Reconnect the negative (-) lead last when reconnecting the battery. Never connect the negative (-) battery cable to the positive (+) connection terminal of the starter solenoid. Do not test the battery condition by shorting the terminals together.

**Connecting the battery and the battery charger. Hazardous voltage will cause severe injury or death.** Reconnect the battery correctly, positive to positive and negative to negative, to avoid electrical shock and damage to the battery charger and battery(ies). Have a qualified electrician install the battery(ies).

Starting batteries are usually the lead-acid type. Use a 12-volt group 51 battery with a minimum rating of 500 cold cranking amps at 0°F. The generator set uses a negative ground with a 12-volt engine electrical system. See Figure 33 for battery connections. Make sure that the battery is correctly connected and the terminals are tight.

**Note:**

The generator set will not start and circuit board damage may occur if the battery is connected in reverse.

See the dimension drawing in the Drawings and Diagrams section for the engine starting battery location on the air intake side of the generator set. Standard battery cables provide easy connection to the battery.

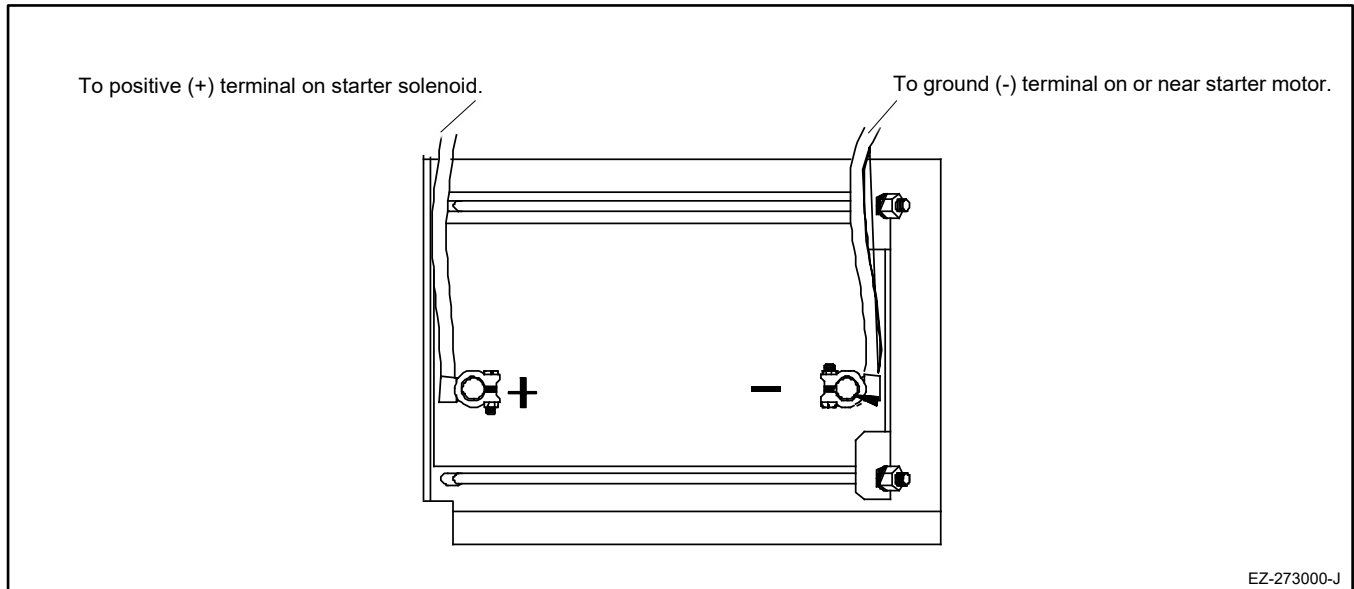

Figure 33 Typical Battery Connection

Use the following procedure to install and connect the battery.

**Battery Installation Procedure**

1. Ensure that the starting battery is fully charged before placing the battery in service.
2. Clean the battery posts and/or adapters if necessary.
3. Install the battery post adapters, if needed.
4. Place the battery in the housing.

**Note:**

Ensure that the battery is positioned toward the front of the generator so it does not block the alternator air intake vent. See the Remove Left Panel figure.

5. Connect the positive (+) lead to the engine starting battery.
6. Connect the negative (-) lead to the engine starting battery.

Refer to the generator set operation manual and the battery manufacturer's instructions for battery maintenance instructions.

When power is applied to the RDC2 controller (that is, when the battery is connected), you will be prompted to set the date and time, and then to set the exerciser. See the Set Exerciser section and the generator set operation manual for instructions.

If the battery is disconnected for service or replacement, the exercise settings on the RDC2 controller are lost. Set the exerciser after installing and connecting the battery. See the Set Exerciser section.

## 1.12 Prestart Installation Check

Review the entire installation section. Inspect all wiring and connections to verify that the generator set is ready for operation. Check all items in the following Prestart Checklist.

### Prestart Checklist

**Air Cleaner.** Check that a clean air cleaner element is installed to prevent unfiltered air from entering the engine. See the generator set operation manual for instructions.

**Air Inlets.** Check for clean and unobstructed air inlets.

**Battery.** Check for tight battery connections. Consult the battery manufacturer's instructions regarding battery care and maintenance.

**Enclosure.** Check that all enclosure panels and internal baffling are in place.

**Exhaust System.** Check for exhaust leaks and blockages. Check the muffler condition.

- Inspect the exhaust system components for cracks, leaks, and corrosion. Check for tight exhaust system connections.
- Check for corroded or broken metal parts and replace them as needed.
- Check that the exhaust outlet is unobstructed.

**Oil Level.** Maintain the oil level at or near, not over, the full mark on the dipstick.

**Operating Area.** Check for obstructions that could block the flow of cooling air. Keep the air intake area clean. Do not leave rags, tools, or debris on or near the generator set.

## 1.13 Set the Exerciser

Set the exerciser to automatically run the generator set on the desired day and time every week or every two weeks. See the generator set Operation Manual for detailed descriptions of the unloaded and loaded exercise operation.

### 1.13.1 RDC2 Controller

When power is applied to the RDC2 controller (when the battery or the utility power for the battery charger is connected), you will be prompted to set the date and time, and then to set the exerciser.

The first setting will flash. Press the Up and Down arrow buttons to change the setting. Press Select to save the setting and move on to the next. Repeat until the date, time, and exercise are set and the controller display shows the main menu. See the generator set Operation Manual for more detailed instructions to set the date and time and set the exerciser.

Press AUTO to place the generator set controller into automatic mode.

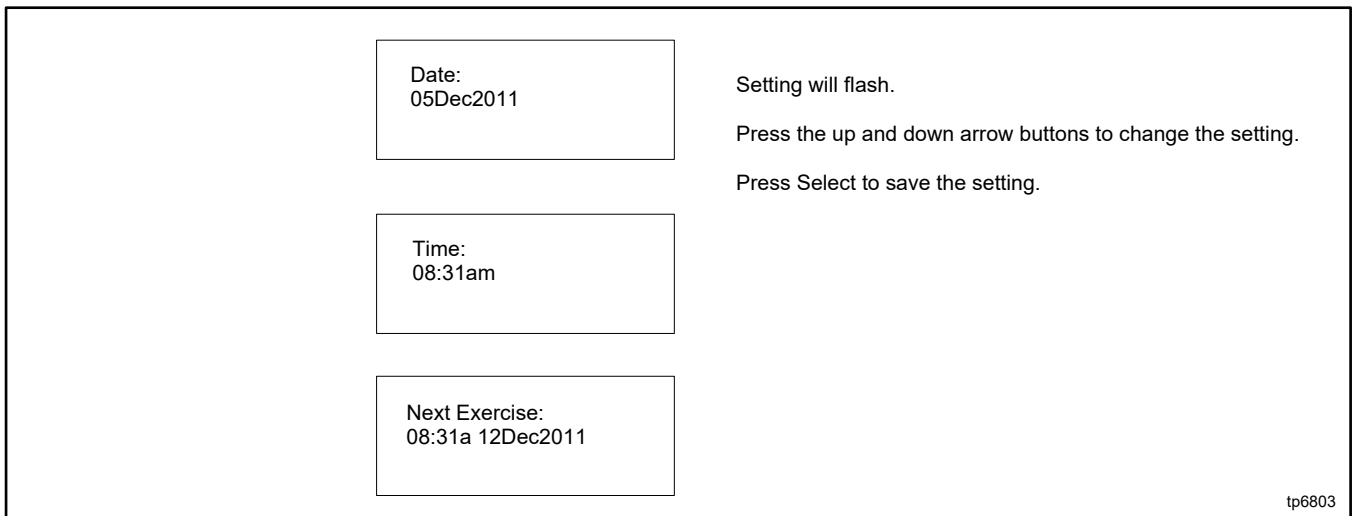





Figure 34 Set Time, Date, and Exercise (RDC2)

### 1.13.2 Loaded Exercise

In order to set a loaded exercise using the RDC2 controller, a Model RXT transfer switch must be connected. See the generator set operation manual for instructions to set a loaded exercise.

To set a loaded exercise on a generator set connected to a transfer switch other than a Model RXT, use the transfer switch controller to set the exercise. Refer to the transfer switch operation manual for instructions.

## 1.14 Operation Test

 <b>DANGER</b>	<b>Hazardous voltage. Moving parts. Will cause severe injury or death.</b> Operate the generator set only when all guards and electrical enclosures are in place.
 	

1. Verify that all guards and enclosure panels are in place.
2. Check the items in the Prestart Checklist in the Prestart Installation Check section.
3. Press the RUN button on the generator set controller to start the generator set. Verify that the engine starts and runs.
4. Use a digital voltmeter (DVM) to check the output voltage (line to line and line to neutral) from the generator set. If voltage calibration is required, refer voltage calibration instructions in the service manual.
5. Press OFF to stop the engine. Then press AUTO on the RDC2 controller.
6. Verify that the enclosure door is closed and that the panels are installed. Lock the enclosure to prevent unauthorized access.

## 1.15 KOHLER Energy Management System

The KOHLER Energy Management System allows monitoring and control of your generator set from a smart phone. KOHLER Energy Management app can also be configured to send push notifications in the event of a generator set fault.

### KOHLER Energy Management

KOHLER Energy Management is provided with the generator set. Purchase and install the Wireless kit, or use Ethernet cable to connect the RDC2 controller to the customer-supplied Ethernet router or modem. Route the cable with other low-voltage signal wiring (for example, the RBUS communication leads or engine start leads to the transfer switch), in separate conduit from the AC load leads. If the Ethernet cable is longer than 100 meters (328 ft.), use a repeater or switch.

**Recommended:** Use a laptop computer to verify the network connection before connecting to the generator set.

### Checking the network connection

1. Check for and turn OFF any wireless connections to the laptop.
2. Connect the Ethernet cable to the laptop. Connect the other end of the Ethernet cable to the customer's router or modem.
3. Verify the Internet connection by opening your web browser and going to [kohlergenerators.com](http://kohlergenerators.com) any known website.
4. After verifying the connection through the Ethernet cable, disconnect the Ethernet cable from the laptop and turn the laptop wireless connections back on.

Connect to the Ethernet cable in the customer connection area of the generator set. See Figure 35. Use an RJ45 inline coupler, provided with the wireless kit, to connect the customer's Ethernet cable to the cable in the customer connection box.

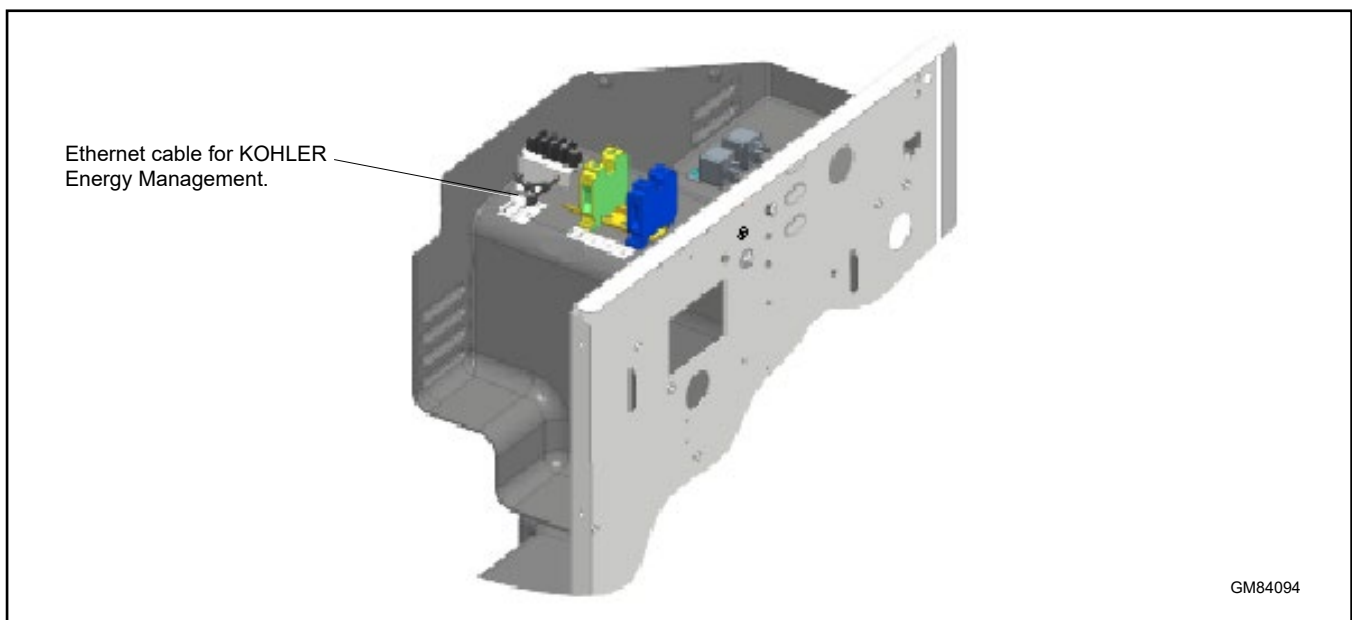

Figure 35 Network Connection for KOHLER Energy Management

### 2.1 Introduction

This section describes some of the accessories that are available for the generator sets. Have accessories installed by an authorized distributor/ dealer or a licensed electrician. This document does not contain installation instructions for accessories. Follow the installation instructions provided with each kit.

Use separate conduit for AC and DC leads to reduce the possibility of electrical interference. Verify that the leads and conduit do not interfere with the operation of the generator set or obstruct the service areas. Verify that the electrical installation complies with the National Electrical Code (NEC) and all applicable local codes. See the wiring diagrams in the Drawings and Diagrams section for more information regarding generator set electrical connections.

### 2.2 Connect Optional Programmable Interface Module (PIM)

The optional programmable interface module (PIM) provides two programmable inputs and six dry contact outputs, four of which are programmable. See TT-1584 for PIM installation and connection instructions. Also see the ATS and Accessory Connections section of this manual for connection to the generator set.

The default settings for the inputs and outputs are shown in Figure 37. To change the input and output settings, use a personal computer running SiteTech® software. See TP-6701, SiteTech Software Operation Manual, for instructions.

KOHLER Energy Management app can be used to actively control PIM outputs.

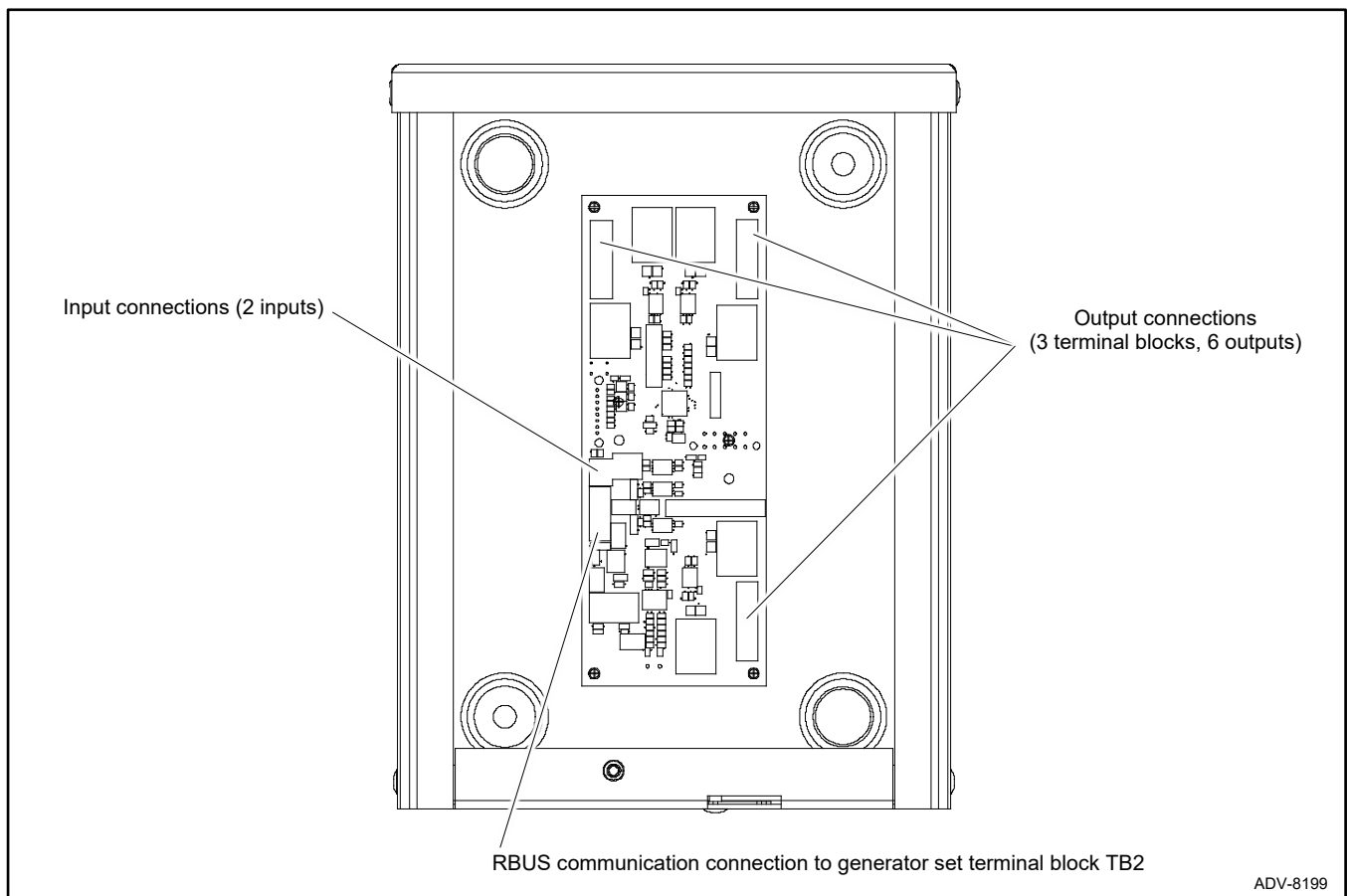

Figure 36 Optional PIM

PIM Connection	Factory Default Setting
Input 1	None
Input 2	None
Output 1 (Relay 1)	Run
Output 2 (Relay 2)	Common Fault
Output 3 (Relay 3)	Low Battery Voltage (Programmable)
Output 4 (Relay 4)	Not in Auto (Programmable)
Output 5 (Relay 5)	Cooldown (Programmable)
Output 6 (Relay 6)	Normal Source Failure (Programmable)

Figure 37 PIM Inputs and Outputs

## 2.3 Load Management

On models 8/10/12RESV, two optional load management devices are available for use when combined with a model RXT and RDT transfer switch:

- The optional Load Shed Kit mounts inside a model RDT or RXT transfer switch. Figure 38 shows the load shed assembly.
- The combined interface/ load management board is available for the Model RXT transfer switch.

**Note:**

Load shed kits are not available with the transfer switch supplied with models 8/10/12RESVL.

The devices provide an automatic load management system to comply with Section 702.5 of NEC 2008.

**Note:**

The load management devices are only compatible with single-phase generator sets.

With a load management system, less critical appliances can be powered by the generator set when the more important appliances are not running, allowing the use of a smaller generator set than would be needed to run all of the building's electrical equipment at the same time.

The load management device automatically manages up to six residential loads.

- Two relays are included to control two independent heating, ventilation, and air conditioning (HVAC) loads.
- Up to four power relays (or load management modules) can be connected through normally open relay contacts on the circuit board. Load management modules are available separately.

Load management modules include one power relay mounted inside a NEMA type 3R enclosure. Connect up to four (4) load management modules to the load management devices listed above.

The load management device receives commands from the RDC2 generator controller and energizes or de-energizes the appropriate load relays to add or shed non-critical loads according to their priority.

**Note:**

Connect only non-essential loads to the load shed kit.

An adequate electrical supply is required for operation of the customer-supplied power relays connected to the load shed kit. Check the electrical requirements of the customer-provided equipment prior to installation to determine the wire size and circuit protection required. The installer is responsible for ensuring that the power system installation complies with all applicable state and local codes.

For detailed installation and connection instructions, see TT-1609, provided with the load shed kit, or TP-6807, Operation/Installation Manual for the Model RXT transfer switch with combined interface/ load management board.

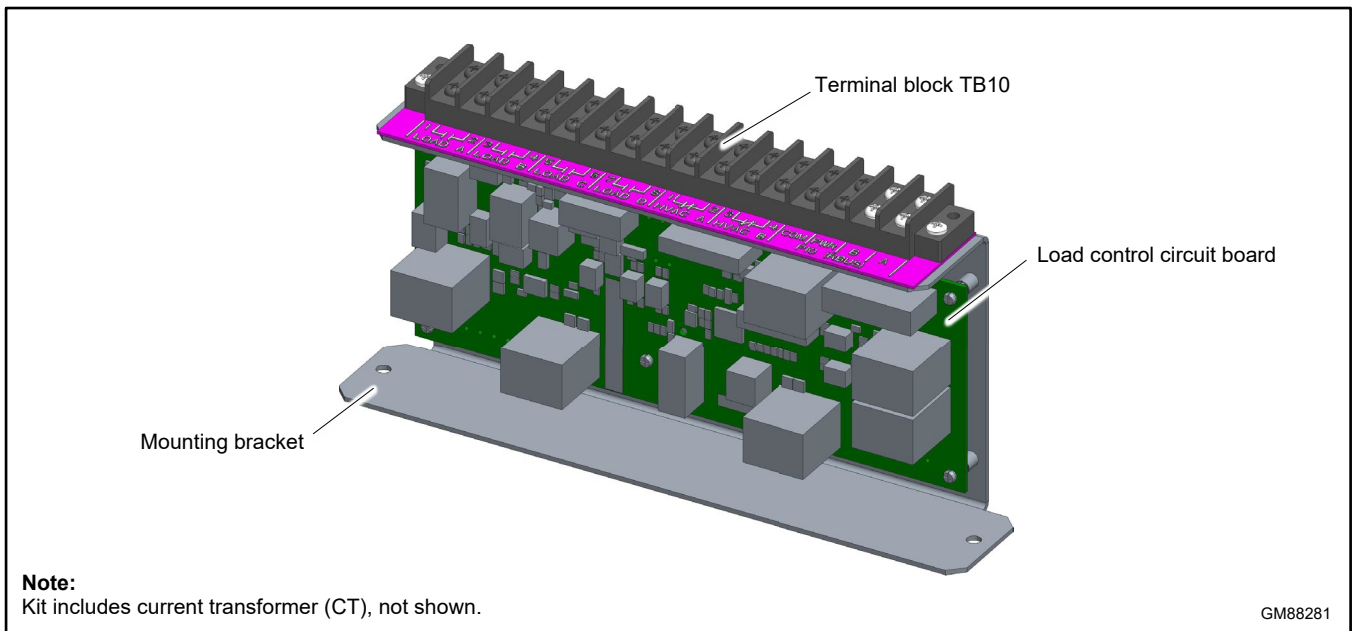

Figure 38 Load Shed Assembly GM88281-1 (mounts inside the transfer switch enclosure)

### 2.3.1 Power Relay Module

The power relay module kit contains one 50 amp relay with connecting lugs in a NEMA type 3R enclosure. Connect up to four (4) power relay modules to the load management devices listed above.



The power relay modules can be mounted indoors or outdoors. Two (2) 120 VAC loads (shed simultaneously) or a single 240 VAC load can be wired to each relay.

For detailed installation and connection instructions, see TT-1646, provided with the power relay module kit.



Figure 39 Power Relay Module

## 2.4 Carburetor Heater

 <b>WARNING</b>	<b>Hot engine and exhaust system. Can cause severe injury or death.</b> Do not work on the generator set until it cools.
	

**Servicing the engine heater. Hot parts can cause minor personal injury or property damage.** Install the heater before connecting it to power. Operating the heater before installation can cause burns and component damage. Disconnect power to the heater and allow it to cool before servicing the heater or nearby parts.

An optional carburetor heater is recommended for improved cold starting in locations where the ambient temperature drops below 0°C (32°F). The carburetor heater prevents condensation and carburetor icing. The heater turns on when the temperature at the thermostat falls below approximately 4°C (40°F) and turns off when the temperature rises above approximately 16°C (60°F). The carburetor heater is shown in Figure 41.

To install the carburetor heater, follow the instructions provided with the kit. Figure 42 shows the installed carburetor heater kit.

Verify that AC power is connected to the generator set as described in the Electrical Connections section. The circuit must be backed up by the generator set to provide power at all times.

The heater thermostat is installed in the cord. Figure 42 shows the location of the thermostat on the power cord. The heater power cord and thermostat are located in the generator set housing air intake area/ battery compartment.

The heater requires a continuous source of power. Plug the carburetor heater into the 120 VAC receptacle provided.

Kit Number	120 Volt Kits
Voltage	120 VAC 50/60 Hz
Thermostat ON	4 ± 4°C (40 ± 7°F)
Thermostat OFF	16 ± 3°C (60 ± 5°F)

Figure 40 Carburetor Heater Specifications

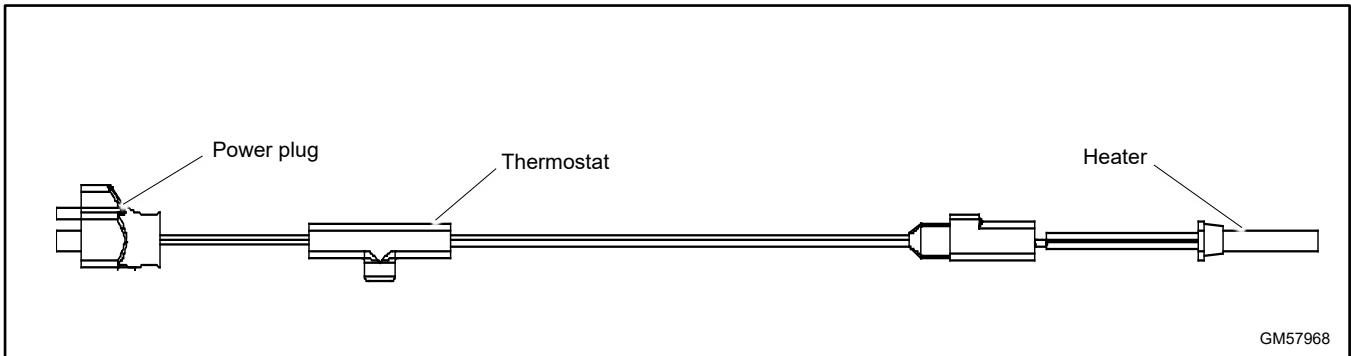

Figure 41 Carburetor Heater

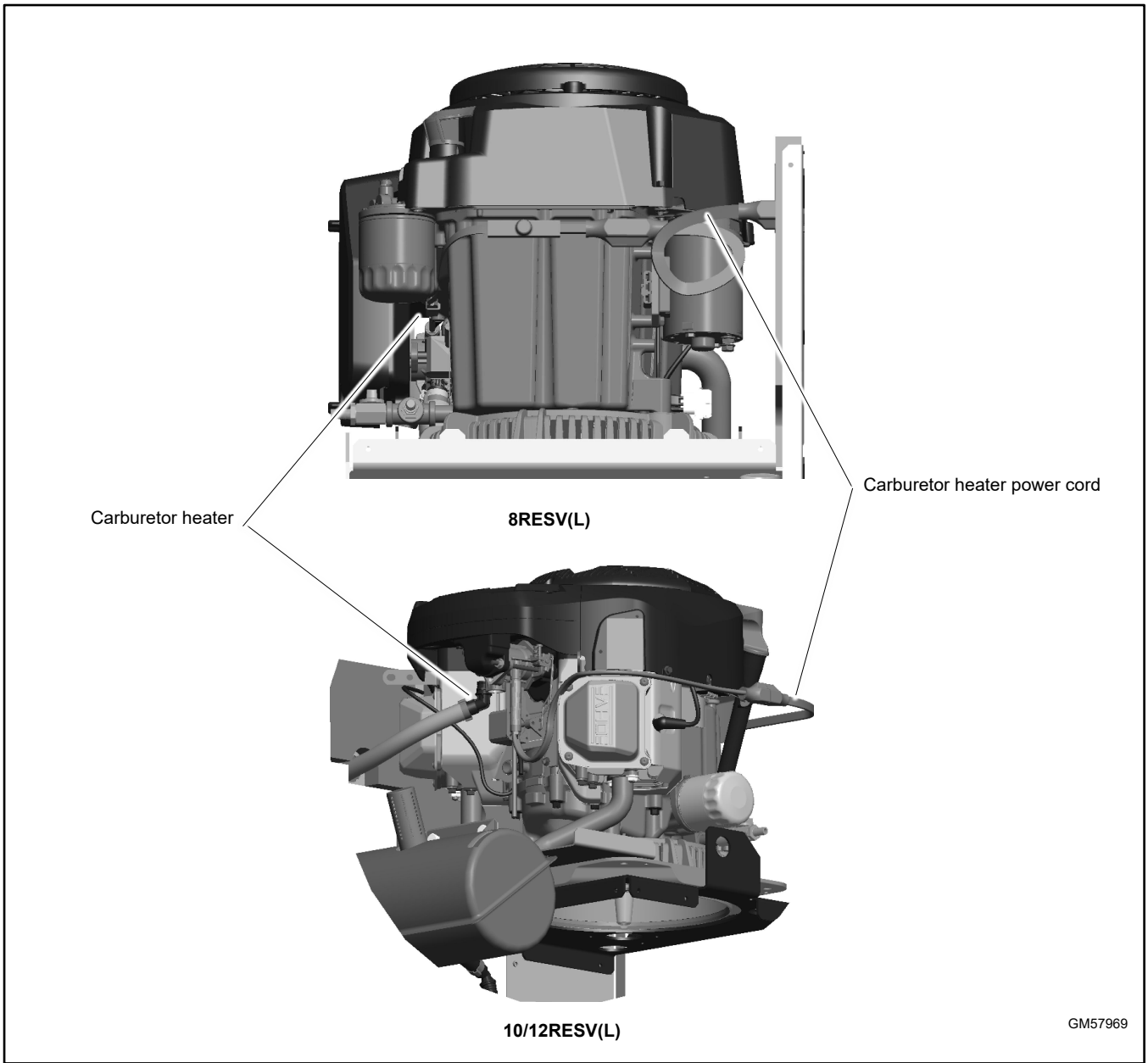

Figure 42 Carburetor Heater Location

# Notes

## Section 3. Drawings and Diagrams

Figure 44 lists the wiring diagram numbers and page numbers.

**Note:**

The reduced minimum clearance from a structure contained in ADV-8774 and ADV-9739 only applies to generators that are compliant with clause (2) of section 4.1.4 of NFPA 37. To verify that the generator is compliant, check the **Specification Number** located on the generator name plate. See Figure 43. If the name plate displays one of the following specification numbers, then the generator is compliant with clause (2) of section 4.1.4 of NFPA 37 and the reduced clearance in ADV-8774 (Figure 47) and ADV-9739 (Figure 50) will apply.

- 8RESV: GM88347-GA7 or higher
- 8RESVL: GM88347-GA10 or higher
- 10RESV: GM114242-GA3
- 10RESVL: GM114242-GA4
- 12RESV: GM114242-GA5
- 12RESVL: GM114242-GA6

**Note:**

If the generator set name plate does not display one of the specification numbers set forth above, refer to ADV-8539 in installation manual TP-6879 for the minimum clearance from a structure.

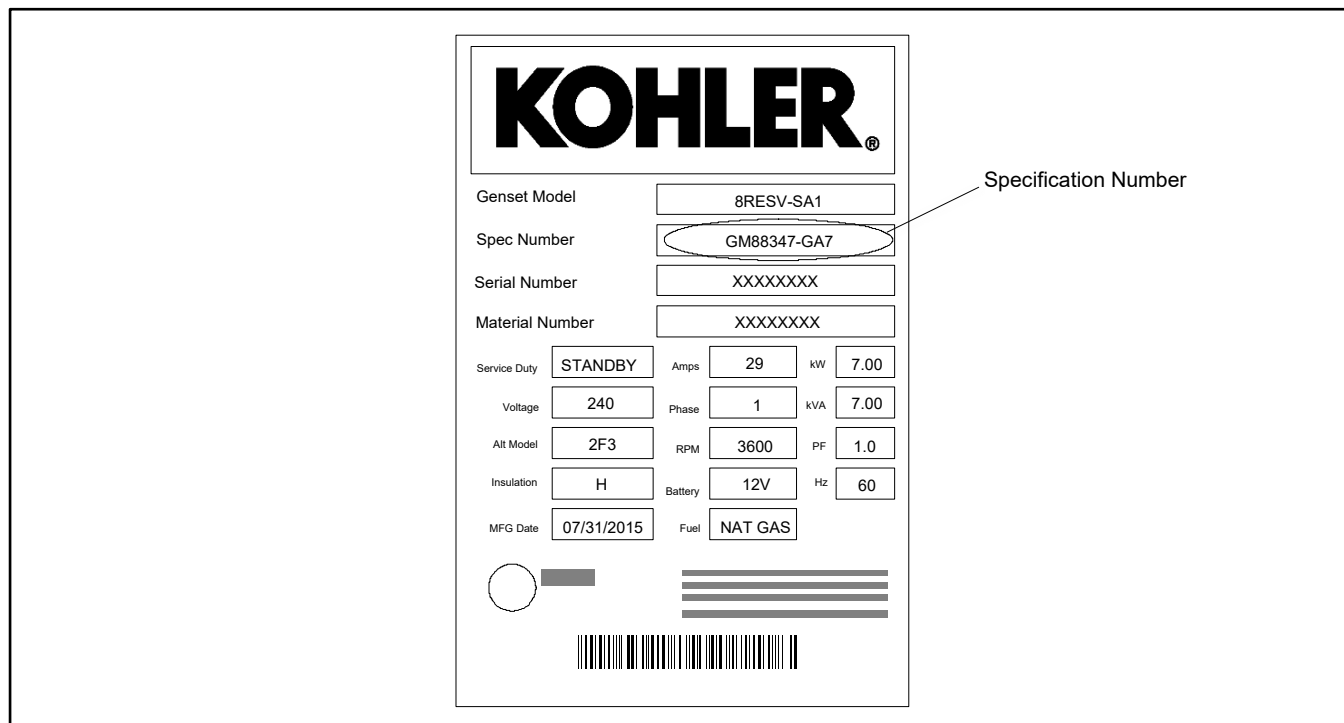

Figure 43 Name Plate

<b>Dimension Drawing</b>	<b>Drawing Number</b>	<b>Page</b>
8RESV(L) Dimension Drawing	ADV-8774, Sheet 1	55
	ADV-8774, Sheet 2	56
	ADV-8774, Sheet 3	57
10\12RESV(L) Dimension Drawing	ADV-9739, Sheet 1	58
	ADV-9739, Sheet 2	59
	ADV-9739, Sheet 3	60
<b>Wiring Diagram Description</b>	<b>Drawing Number</b>	<b>Page</b>
Schematic Diagram	ADV-8552	61
Point-to-Point Wiring Diagram	GM89012	62

Figure 44 Wiring Diagrams and Schematics

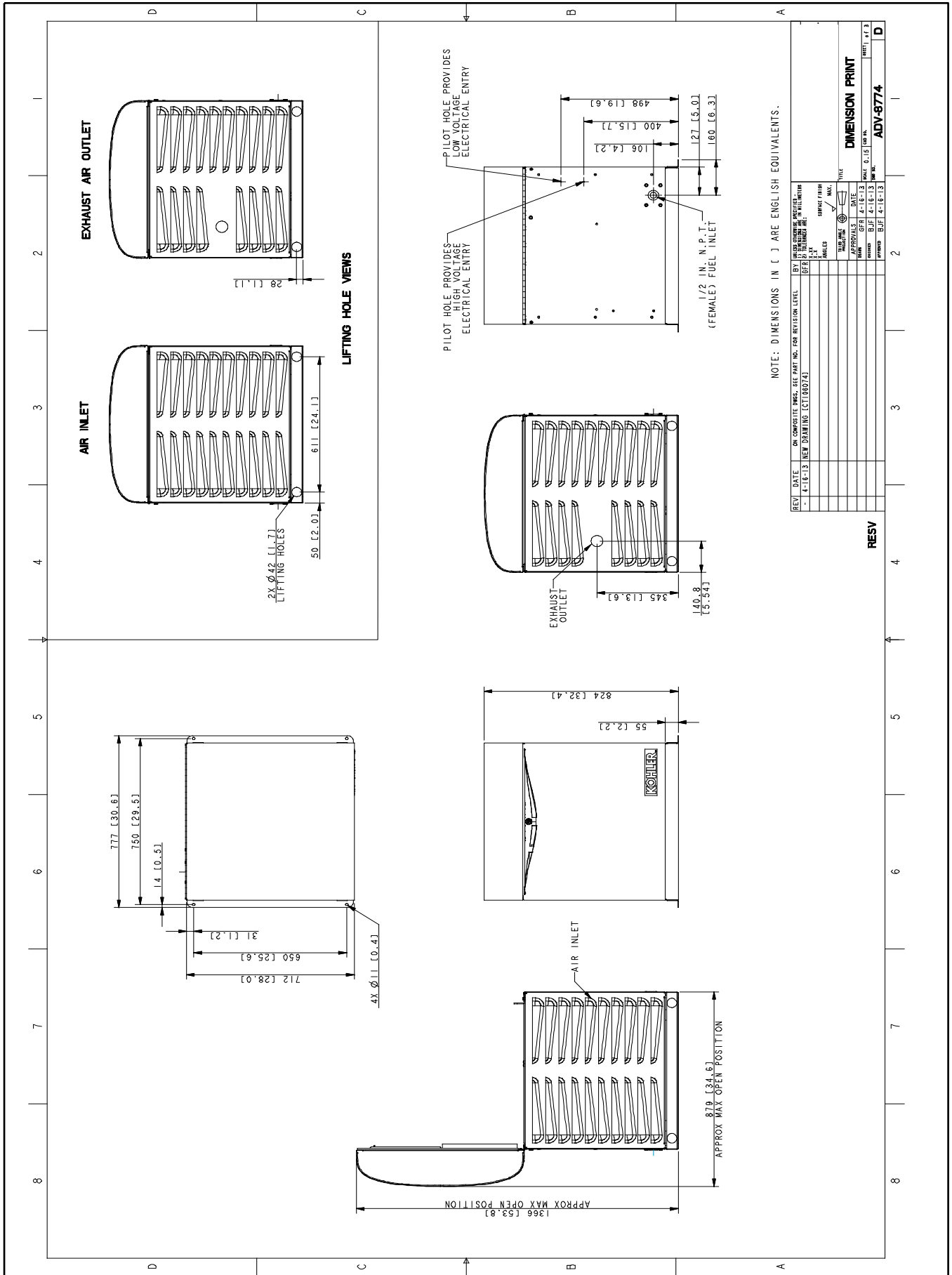

Figure 45 Dimension Drawing ADV-8774, Sheet 1



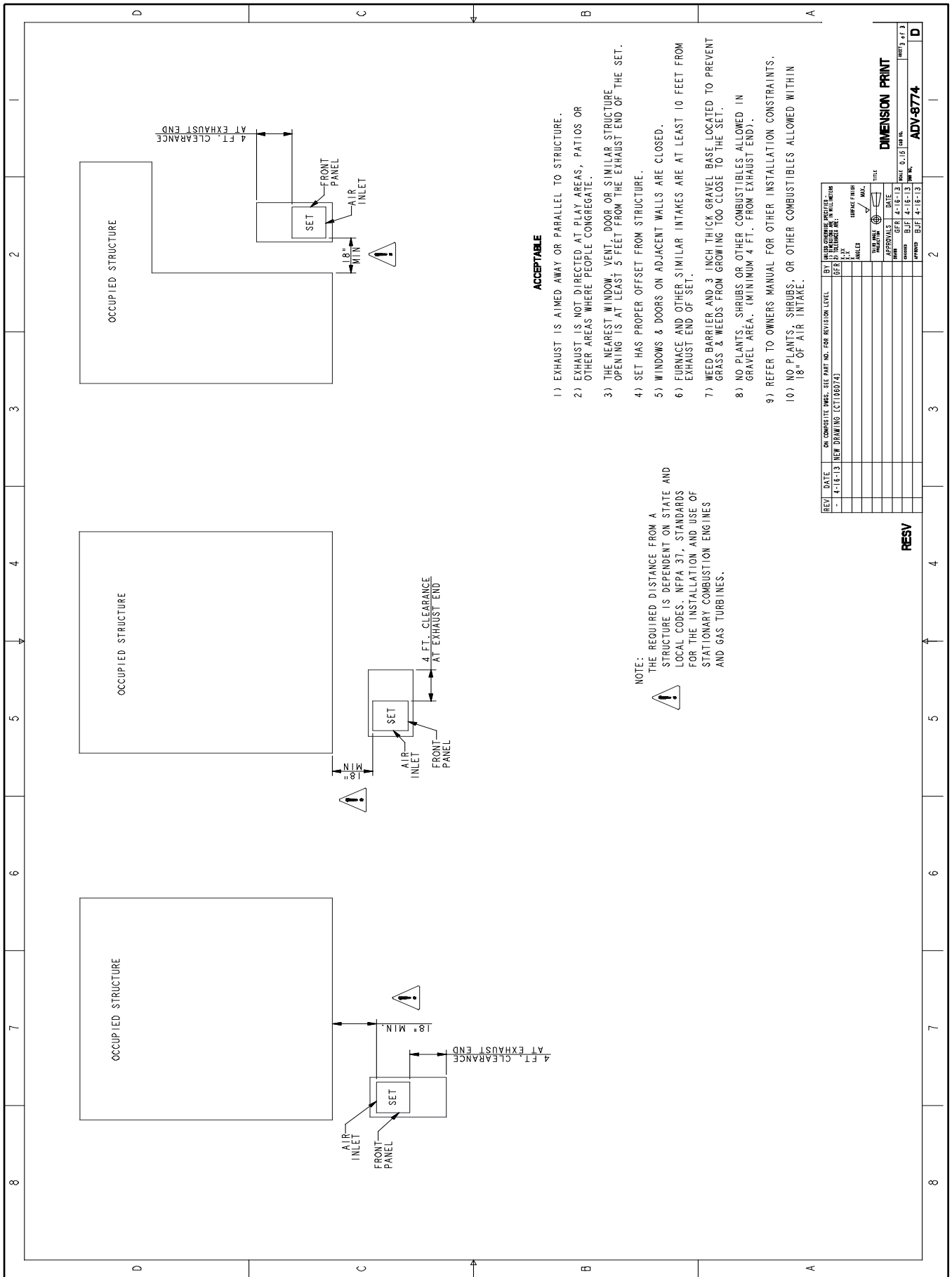

Figure 47 Dimension Drawing ADV-8774, Sheet 3

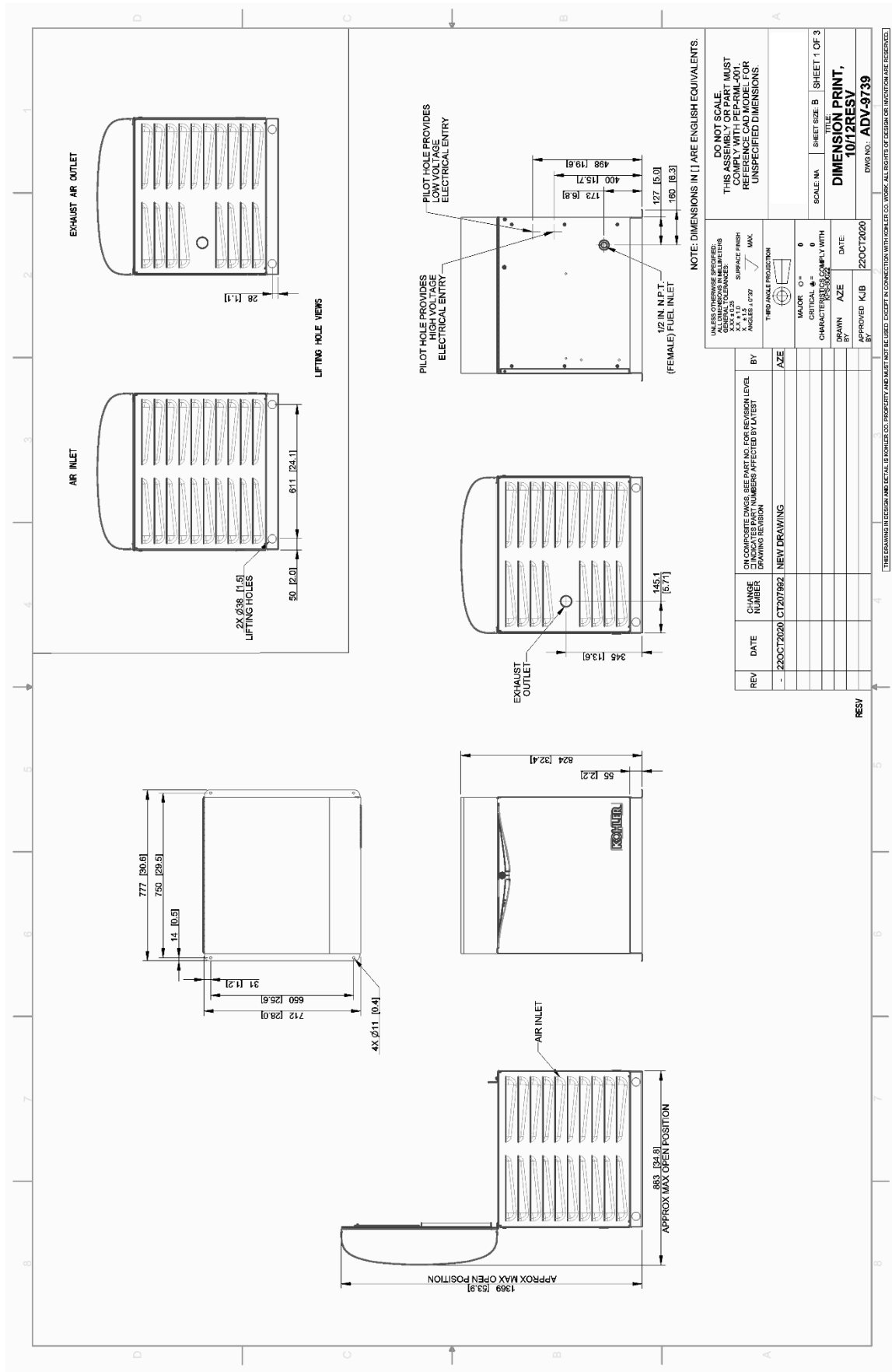

Figure 48 Dimension Drawing ADV-9739, Sheet 1

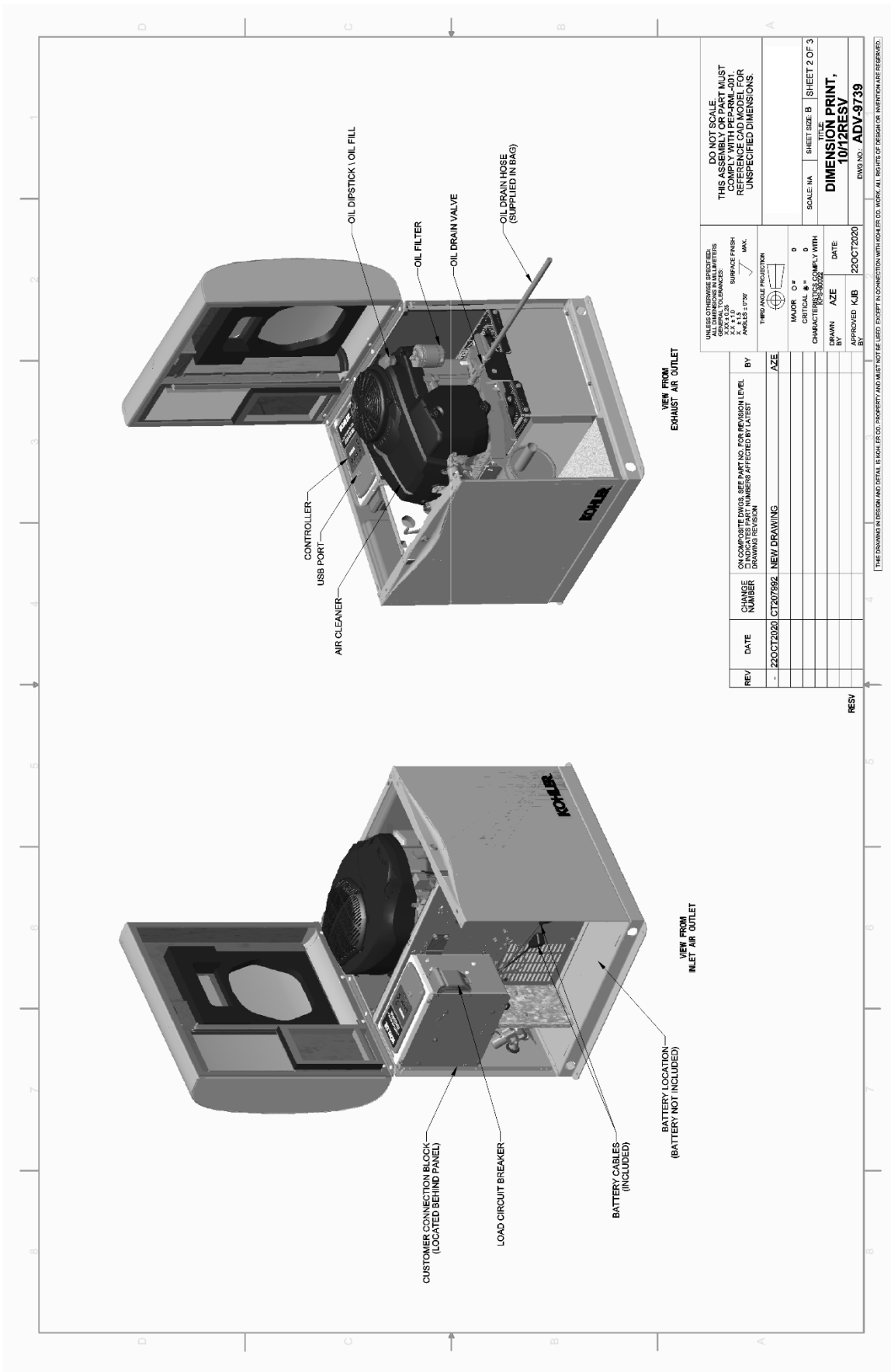
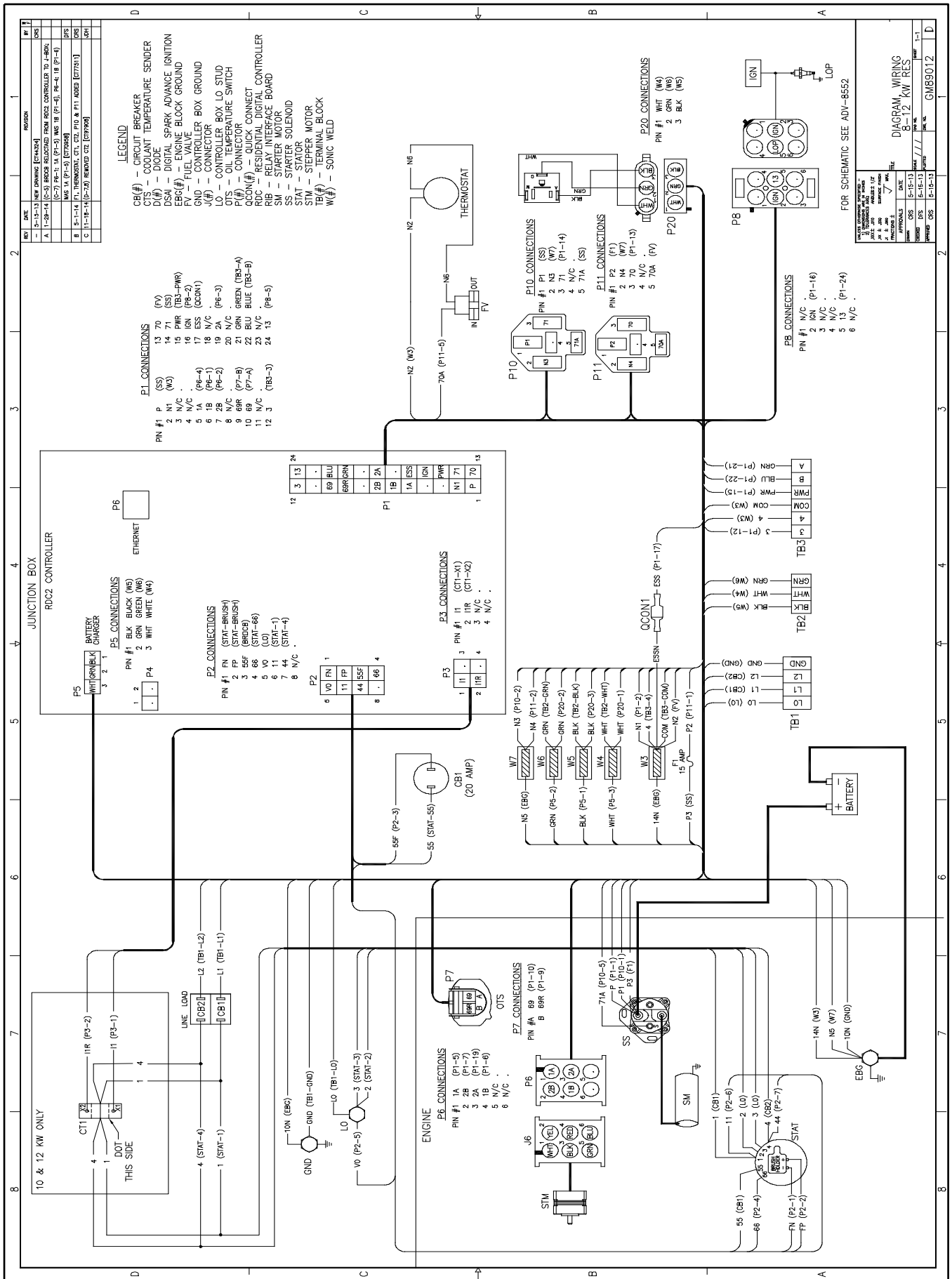

Figure 49 Dimension Drawing ADV-9739, Sheet 2







## Appendix A. Abbreviations

A, amp	ampere	blk. htr.	block heater	DAC	digital to analog converter
ABDC	after bottom dead center	BMEP	brake mean effective pressure	dB	decibel
AC	alternating current	bps	bits per second	dB(A)	decibel (A weighted)
A/D	analog to digital	br.	Brass	DC	direct current
ADC	advanced digital control; analog to digital converter	BTDC	before top dead center	DCR	direct current resistance
adj.	adjust, adjustment	Btu	British thermal unit	DEF	diesel exhaust fluid
ADV	advertising dimensional drawing	Btu/min.	British thermal units per minute	deg., °	degree
AGM	absorbent glass mat	C	Celsius, centigrade	dept.	department
Ah	amp-hour	cal.	Calorie	dia.	Diameter
AHWT	anticipatory high water temperature	CAN	controller area network	DI/EO	dual inlet/end outlet
AISI	American Iron and Steel Institute	CARB	California Air Resources Board	DIN	Deutsches Institut fur Normung e. V. (also Deutsche Industrie Normenausschuss)
ALOP	anticipatory low oil pressure	CAT5	Category 5 (network cable)	DIP	dual inline package
alt.	alternator	CB	circuit breaker	DPDT	double-pole, double-throw
Al	aluminum	CC	crank cycle	DPST	double-pole, single-throw
ANSI	American National Standards Institute (formerly American Standards Association, ASA)	cc	cubic centimeter	DS	disconnect switch
AO	anticipatory only	CCA	cold cranking amps	DVR	digital voltage regulator
APDC	Air Pollution Control District	ccw.	Counterclockwise	E2PROM, EEPROM	electrically-erasable programmable read-only memory
API	American Petroleum Institute	CEC	Canadian Electrical Code	E, emer.	emergency (power source)
approx.	approximate, approximately	cert.	certificate, certification, certified	EATS	Exhaust Aftertreatment System
APU	Auxiliary Power Unit	cfh	cubic feet per hour	ECM	electronic control module, engine control module
AQMD	Air Quality Management District	cfm	cubic feet per minute	EDI	electronic data interchange
AR	as required, as requested	CG	center of gravity	EFR	emergency frequency relay
AS	as supplied, as stated, as suggested	CID	cubic inch displacement	e.g.	for example (exempli gratia)
ASE	American Society of Engineers	CL	centerline	EG	electronic governor
ASME	American Society of Mechanical Engineers	cm	centimeter	EGSA	Electrical Generating Systems Association
assy.	Assembly	CMOS	complementary metal oxide substrate (semiconductor)	EIA	Electronic Industries Association
ASTM	American Society for Testing Materials	com	communications (port)	EI/EO	end inlet/end outlet
ATDC	after top dead center	coml	commercial	EMI	electromagnetic interference
ATS	automatic transfer switch	Coml/Rec	Commercial/Recreational	emiss.	Emission
auto.	Automatic	conn.	Connection	eng.	Engine
aux.	auxiliary	cont.	continued	EPA	Environmental Protection Agency
avg.	average	CPVC	chlorinated polyvinyl chloride	EPS	emergency power system
AVR	automatic voltage regulator	crit.	Critical	ER	emergency relay
AWG	American Wire Gauge	CRM	Common Rail Manifold	ES	engineering special, engineered special
AWM	appliance wiring material	CSA	Canadian Standards Association		
bat.	Battery	CT	current transformer	ESD	electrostatic discharge
BBDC	before bottom dead center	Cu	copper	est.	estimated
BC	battery charger, battery charging	cUL	Canadian Underwriter's Laboratories	E-Stop	emergency stop
BCA	battery charging alternator	cu. in.	cubic inch	etc.	et cetera (and so forth)
BCI	Battery Council International	cw.	Clockwise	exh.	exhaust
BDC	before dead center	CWC	city water-cooled	ext.	external
BHP	brake horsepower	cyl.	Cylinder	F	Fahrenheit, female
blk.	black (paint color), block (engine)	D/A	digital to analog	FDS	Fluid Dosing System

FHM	flat head machine (screw)	in.	inch	Lpm	liters per minute
fl. oz.	fluid ounce	in. H <sub>2</sub> O	inches of water	LOP	low oil pressure
flex.	flexible	in. Hg	inches of mercury	LP	liquefied petroleum
freq.	frequency	in. Lb.	inch pounds	LPG	liquefied petroleum gas
FS	full scale	Inc.	incorporated	LS	left side
ft.	foot, feet	ind.	Industrial	L <sub>wa</sub>	sound power level, A weighted
ft. lb.	foot pounds (torque)	int.	internal	LWL	low water level
ft./min.	feet per minute	int./ext.	internal/external	LWT	low water temperature
ftp	file transfer protocol	I/O	input/output	m	meter, milli (1/1000)
g	gram	IP	internet protocol	M	mega (10 <sup>6</sup> when used with SI units), male
ga.	gauge (meters, wire size)	ISO	International Organization for Standardization	m <sup>3</sup>	cubic meter
gal.	gallon	J	joule	m <sup>3</sup> /hr.	cubic meters per hour
gen.	generator	JIS	Japanese Industry Standard	m <sup>3</sup> /min.	cubic meters per minute
genset	generator set	k	kilo (1000)	mA	milliampere
GFI	ground fault interrupter	K	kelvin	man.	manual
GND, ⊕	ground	kA	kiloampere	max.	maximum
gov.	governor	KB	kilobyte (2 <sup>10</sup> bytes)	MB	megabyte (2 <sup>20</sup> bytes)
gph	gallons per hour	KBus	Kohler communication protocol	MCCB	molded-case circuit breaker
gpm	gallons per minute	kg	kilogram	MCM	one thousand circular mils
gr.	grade, gross	kg/cm <sup>2</sup>	kilograms per square centimeter	megggar	megohmmeter
GRD	equipment ground	kgm	kilogram-meter	MHz	megahertz
gr. wt.	gross weight	kg/m <sup>3</sup>	kilograms per cubic meter	mi.	mile
H x W x D	height by width by depth	kHz	kilohertz	mil	one one-thousandth of an inch
HC	hex cap	kJ	kilojoule	min.	minimum, minute
HCHT	high cylinder head temperature	km	kilometer	misc.	miscellaneous
HD	heavy duty	kOhm, kΩ	kilo-ohm	MJ	megajoule
HET	high exhaust temp., high engine temp.	kPa	kilopascal	mJ	millijoule
hex	hexagon	kph	kilometers per hour	mm	millimeter
Hg	mercury (element)	kV	kilovolt	mOhm, mΩ	milliohm
HH	hex head	kVA	kilovolt ampere	MOhm, MΩ	megohm
HHC	hex head cap	kVAR	kilovolt ampere reactive	MOV	metal oxide varistor
HP	horsepower	kW	kilowatt	MPa	megapascal
hr.	hour	kWh	kilowatt-hour	mpg	miles per gallon
HS	heat shrink	kWm	kilowatt mechanical	mph	miles per hour
hsg.	Housing	kWth	kilowatt-thermal	MS	military standard
HVAC	heating, ventilation, and air conditioning	L	liter	ms	millisecond
HWT	high water temperature	LAN	local area network	m/sec.	meters per second
Hz	hertz (cycles per second)	L x W x H	length by width by height	mtg.	mounting
IBC	International Building Code	lb.	pound, pounds	MTU	Motoren-und Turbinen-Union
IC	integrated circuit	lbm/ft <sup>3</sup>	pounds mass per cubic feet	MW	megawatt
ID	inside diameter, identification	LCB	line circuit breaker	mW	milliwatt
IEC	International Electrotechnical Commission	LCD	liquid crystal display	μF	microfarad
IEEE	Institute of Electrical and Electronics Engineers	LED	light emitting diode	μF	microfarad
IMS	improved motor starting	Lph	liters per hour		

N, norm.	normal (power source)	PMG	permanent magnet generator	SCR	silicon controlled rectifier (electrical), selective catalytic reduction (exhaust emissions)
NA	not available, not applicable	pot	potentiometer, potential	s, sec.	second
nat. gas	natural gas	ppm	parts per million	SI	<i>Systeme international d'unites</i> , International System of Units
NBS	National Bureau of Standards	PROM	programmable read-only memory	SI/EO	side in/end out
NC	normally closed	psi	pounds per square inch	sil.	Silencer
NEC	National Electrical Code	psig	pounds per square inch gauge	SMTP	simple mail transfer protocol
NEMA	National Electrical Manufacturers Association	pt.	pint	SN	serial number
NiCd	nickel cadmium	PTC	positive temperature coefficient	SNMP	simple network management protocol
NFPA	National Fire Protection Association	PTO	power takeoff	SPDT	single-pole, double-throw
Nm	newton meter	PVC	polyvinyl chloride	SPST	single-pole, single-throw
NO	normally open	PVC	polyvinyl chloride	spec	specification
no., nos.	number, numbers	PWM	pulse width modulated, pulse width modulation	specs	specification(s)
NPS	National Pipe, Straight	qt.	quart, quarts	sq.	square
NPSC	National Pipe, Straight-coupling	qty.	quantity	sq. cm	square centimeter
NPT	National Standard taper pipe thread per general use	R	replacement (emergency) power source	sq. in.	square inch
NPTF	National Pipe, Taper-Fine	rad.	radiator, radius	SMS	short message service
NR	not required, normal relay	RAM	random access memory	SS	stainless steel
Ns	nanosecond	RDO	relay driver output	std.	standard
OC	overcrank	ref.	reference	stl.	Steel
OD	outside diameter	rem.	Remote	tach.	Tachometer
OEM	original equipment manufacturer	Res/Com	Residential/Commercial	TB	terminal block
OF	overfrequency	RFI	radio frequency interference	TCP	transmission control protocol
opt.	option, optional	RH	round head	TD	time delay
OS	oversize, overspeed	RHM	round head machine (screw)	TDC	top dead center
OSHA	Occupational Safety and Health Administration	rly.	Relay	TDEC	time delay engine cooldown
OSHPD	Office of Statewide Health Planning and Development (California)	rms	root mean square	TDEN	time delay emergency to normal
OV	overvoltage	rnd.	Round	TDES	time delay engine start
oz.	ounce	RO	read only	TDNE	time delay normal to emergency
p., pp.	page, pages	ROM	read only memory	TDOE	time delay off to emergency
PC	personal computer	rot.	rotate, rotating	TDON	time delay off to normal
PCB	printed circuit board	rpm	revolutions per minute	temp.	temperature
pF	picofarad	RS	right side	term.	Terminal
PF	power factor	RTDs	resistance temperature detectors	THD	total harmonic distortion
ph., ø	phase	RTU	remote terminal unit	TIF	telephone influence factor
PHC	Phillips® head Crimptiter (screw)	RTV	room temperature vulcanization	tol.	Tolerance
PHH	Phillips® hex head (screw)	RW	read/write	turbo.	Turbocharger
PHM	pan head machine (screw)	SAE	Society of Automotive Engineers	typ.	typical (same in multiple locations)
PLC	programmable logic control	scfm	standard cubic feet per minute	UF	underfrequency

UHF	ultrahigh frequency
UIF	user interface
UL	Underwriter's Laboratories, Inc.
UNC	unified coarse thread (was NC)
UNF	unified fine thread (was NF)
univ.	universal
URL	uniform resource locator (web address)
US	undersize, underspeed
UV	ultraviolet, undervoltage
V	volt
VAC	volts alternating current
VAR	voltampere reactive
VDC	volts direct current
VFD	vacuum fluorescent display
VGA	video graphics adapter
VHF	very high frequency
W	watt
WCR	withstand and closing rating
w/	with
WO	write only
w/o	without
wt.	weight
xfmr	transformer

# Notes

**TP-6984 426f**

*Original Instructions (English)*

© 2026 Discovery Energy, LLC - All rights reserved.

# **KOHLER**<sup>®</sup> Generators

Discovery Energy, LLC  
200 Twin Oaks Road, Kohler, WI 53044 USA  
For the nearest sales and service outlet in the  
US and Canada, phone 1-800-544-2444  
[kohlergenerators.com](http://kohlergenerators.com)

