

# Installation

## Residential/Commercial Generator Sets



Model:

**12RES**

Controller:

**Advanced Digital Control ADC-RES**

**▲ WARNING:** This product can expose you to chemicals, including carbon monoxide and benzene, which are known to the State of California to cause cancer and birth defects or other reproductive harm. For more information go to [www.P65warnings.ca.gov](http://www.P65warnings.ca.gov)

**Kohler strongly recommends that only factory-authorized dealers install and service the generator.**

## Product Identification Information

---

### Generator Set Identification Numbers

Record the product identification numbers from the generator set nameplate(s).

Model Designation \_\_\_\_\_

Specification Number \_\_\_\_\_

Serial Number \_\_\_\_\_

### Controller Identification

Record the controller description from the generator set operation manual, spec sheet, or sales invoice.

Controller Description \_\_\_\_\_

### Engine Identification

Record the product identification information from the engine nameplate.

Manufacturer \_\_\_\_\_

Model Designation \_\_\_\_\_

Serial Number \_\_\_\_\_

Accessory Number	Accessory Description

Accessory Number	Accessory Description

# Table of Contents

<b>Safety Precautions and Instructions</b> .....	<b>5</b>
<b>Introduction</b> .....	<b>11</b>
<b>Service Assistance</b> .....	<b>12</b>
<b>Section 1. Installation</b> .....	<b>13</b>
1.1 Introduction .....	13
1.2 Lifting.....	14
1.3 Generator Set Inspection .....	14
1.4 Location and Mounting .....	14
1.4.1 Exhaust Requirements.....	15
1.4.2 Air Requirements .....	15
1.5 Power Supply .....	16
1.6 Fuel Requirements .....	16
1.6.1 Fuel Supply .....	17
1.6.2 Fuel Pipe Size.....	17
1.7 Fuel Conversion .....	18
1.7.1 Fuel Conversion, Original Fuel System.....	19
1.7.2 Fuel Conversion, Revised Fuel System .....	21
1.8 Electrical Connections.....	24
1.8.1 Field Connections .....	25
1.8.2 Remote Start Connection.....	26
1.8.3 Grounding .....	26
1.8.4 Battery Charger.....	26
1.9 Battery.....	27
1.10 Accessories.....	29
1.10.1 Common Fault and Auxiliary Run Relay Board.....	29
1.10.2 Carburetor Heater .....	30
1.11 Prestart Installation Check .....	31
1.12 Controller Configuration .....	32
1.12.1 System Parameters .....	32
1.12.2 Application Code Version.....	33
1.13 Voltage and Frequency Adjustments.....	34
1.13.1 Voltage Adjustment.....	35
1.13.2 Frequency Adjustment .....	36
<b>Section 2. Dimension Drawings and Wiring Diagrams</b> .....	<b>39</b>
<b>Appendix A. Abbreviations</b> .....	<b>45</b>

## Notes

# Safety Precautions and Instructions

**IMPORTANT SAFETY INSTRUCTIONS.** Electromechanical equipment, including generator sets, transfer switches, switchgear, and accessories, can cause bodily harm and pose life-threatening danger when improperly installed, operated, or maintained. To prevent accidents be aware of potential dangers and act safely. Read and follow all safety precautions and instructions. **SAVE THESE INSTRUCTIONS.**

This manual has several types of safety precautions and instructions: Danger, Warning, Caution, and Notice.



DANGER indicates a hazardous situation which, if not avoided, will result in death or serious injury.



WARNING indicates a hazardous situation which, if not avoided, could result in death or serious injury.



CAUTION indicates a hazardous situation which, if not avoided, could result in minor or moderate injury.

## NOTICE

NOTICE is used to address practices not related to physical injury.





Safety decals affixed to the equipment in prominent places alert the operator or service technician to potential hazards and explain how to act safely. The decals are shown throughout this publication to improve operator recognition. Replace missing or damaged decals.

## Accidental Starting

	<b>Accidental starting.</b> <b>Can cause severe injury or death.</b>
	Disconnect the battery cables before working on the generator set. Remove the negative (-) lead first when disconnecting the battery. Reconnect the negative (-) lead last when reconnecting the battery.

**Disabling the generator set. Accidental starting can cause severe injury or death.** Before working on the generator set or equipment connected to the set, disable the generator set as follows: (1) Move the generator set master switch to the OFF position. (2) Disconnect the power to the battery charger. (3) Remove the battery cables, negative (-) lead first. Reconnect the negative (-) lead last when reconnecting the battery. Follow these precautions to prevent starting of the generator set by an automatic transfer switch, remote start/stop switch, or engine start command from a remote computer.

## Battery

 <b>WARNING</b>	<b>Sulfuric acid in batteries.</b> <b>Can cause severe injury or death.</b> Wear protective goggles and clothing. Battery acid may cause blindness and burn skin.
	
 <b>WARNING</b>	<b>Explosion.</b> <b>Can cause severe injury or death.</b> <b>Relays in the battery charger cause arcs or sparks.</b> Locate the battery in a well-ventilated area. Isolate the battery charger from explosive fumes.
	

**Battery electrolyte is a diluted sulfuric acid. Battery acid can cause severe injury or death.** Battery acid can cause blindness and burn skin. Always wear splashproof safety goggles, rubber gloves, and boots when servicing the battery. Do not open a sealed battery or mutilate the battery case. If battery acid splashes in the eyes or on the skin, immediately flush the affected area for 15 minutes with large quantities of clean water. Seek immediate medical aid in the case of eye contact. Never add acid to a battery after placing the battery in service, as this may result in hazardous spattering of battery acid.

**Battery acid cleanup. Battery acid can cause severe injury or death.** Battery acid is electrically conductive and corrosive. Add 500 g (1 lb.) of bicarbonate of soda (baking soda) to a container with 4 L (1 gal.) of water and mix the neutralizing solution. Pour the neutralizing solution on the spilled battery acid and continue to add the neutralizing solution to the spilled battery acid until all evidence of a chemical reaction (foaming) has ceased. Flush the resulting liquid with water and dry the area.

**Battery gases. Explosion can cause severe injury or death.** Battery gases can cause an explosion. Do not smoke or permit flames or sparks to occur near a battery at any time, particularly when it is charging. Do not dispose of a battery in a fire. To prevent burns and sparks that could cause an explosion, avoid touching the battery terminals with tools or other metal objects. Remove all jewelry before servicing the equipment. Discharge static electricity from your body before touching batteries by first touching a grounded metal surface away from the battery. To avoid sparks, do not disturb the battery charger connections while the battery is charging. Always turn the battery charger off before disconnecting the battery connections. Ventilate the compartments containing batteries to prevent accumulation of explosive gases.

**Battery short circuits. Explosion can cause severe injury or death.** Short circuits can cause bodily injury and/or equipment damage. Disconnect the battery before generator set installation or maintenance. Remove all jewelry before servicing the equipment. Use tools with insulated handles. Remove the negative (-) lead first when disconnecting the battery. Reconnect the negative (-) lead last when reconnecting the battery. Never connect the negative (-) battery cable to the positive (+) connection terminal of the starter solenoid. Do not test the battery condition by shorting the terminals together.

## Engine Backfire/Flash Fire



 <b>WARNING</b>	<b>Risk of fire.</b> <b>Can cause severe injury or death.</b>
	Do not smoke or permit flames or sparks near fuels or the fuel system.

**Servicing the air cleaner. A sudden backfire can cause severe injury or death.** Do not operate the generator set with the air cleaner removed.

**Servicing the fuel system. A flash fire can cause severe injury or death.** Do not smoke or permit flames or sparks near the carburetor, fuel line, fuel filter, fuel pump, or other potential sources of spilled fuels or fuel vapors. Catch fuels in an approved container when removing the fuel line or carburetor.

**Combustible materials. A fire can cause severe injury or death.** Generator set engine fuels and fuel vapors are flammable and explosive. Handle these materials carefully to minimize the risk of fire or explosion. Equip the compartment or nearby area with a fully charged fire extinguisher. Select a fire extinguisher rated ABC or BC for electrical fires or as recommended by the local fire code or an authorized agency. Train all personnel on fire extinguisher operation and fire prevention procedures.

## Exhaust System

 <b>WARNING</b>	<b>Carbon monoxide.</b> <b>Can cause severe nausea, fainting, or death.</b>
	The exhaust system must be leakproof and routinely inspected.

**Generator set operation. Carbon monoxide can cause severe nausea, fainting, or death.** Carbon monoxide is an odorless, colorless, tasteless, nonirritating gas that can cause death if inhaled for even a short time. Avoid breathing exhaust fumes when working on or near the generator set. Never operate the generator set inside a building. Never operate the generator set where exhaust gas could seep inside or be drawn into a potentially occupied building through windows, air intake vents, or other openings.



**Carbon monoxide detectors. Carbon monoxide can cause severe nausea, fainting, or death.** Install carbon monoxide detectors on each level of any building adjacent to the generator set. Locate the detectors to adequately warn the building's occupants of the presence of carbon monoxide. Keep the detectors operational at all times. Periodically test and replace the carbon monoxide detectors according to the manufacturer's instructions.

**Carbon monoxide symptoms. Carbon monoxide can cause severe nausea, fainting, or death.** Carbon monoxide is a poisonous gas present in exhaust gases. Carbon monoxide is an odorless, colorless, tasteless, nonirritating gas that can cause death if inhaled for even a short time. Carbon monoxide poisoning symptoms include but are not limited to the following:

- Light-headedness, dizziness
- Physical fatigue, weakness in joints and muscles
- Sleepiness, mental fatigue, inability to concentrate or speak clearly, blurred vision
- Stomachache, vomiting, nausea

If experiencing any of these symptoms and carbon monoxide poisoning is possible, seek fresh air immediately and remain active. Do not sit, lie down, or fall asleep. Alert others to the possibility of carbon monoxide poisoning. Seek medical attention if the condition of affected persons does not improve within minutes of breathing fresh air.



## Fuel System

 <b>WARNING</b>	<b>Explosive fuel vapors. Can cause severe injury or death.</b>
 	Use extreme care when handling, storing, and using fuels.

**The fuel system. Explosive fuel vapors can cause severe injury or death.** Vaporized fuels are highly explosive. Use extreme care when handling and storing fuels. Store fuels in a well-ventilated area away from spark-producing equipment and out of the reach of children. Never add fuel to the tank while the engine is running because spilled fuel may ignite on contact with hot parts or from sparks. Do not smoke or permit flames or sparks to occur near sources of spilled fuel or fuel vapors. Keep the fuel lines and connections tight and in good condition. Do not replace flexible fuel lines with rigid lines. Use flexible sections to avoid fuel line breakage caused by vibration. Do not operate the generator set in the presence of fuel leaks, fuel accumulation, or sparks. Repair fuel systems before resuming generator set operation.









**Gas fuel leaks. Explosive fuel vapors can cause severe injury or death.** Fuel leakage can cause an explosion. Check the LPG vapor or natural gas fuel system for leakage by using a soap and water solution with the fuel system test pressurized to 6–8 ounces per square inch (10–14 inches water column). Do not use a soap solution containing either ammonia or chlorine because both prevent bubble formation. A successful test depends on the ability of the solution to bubble.

## Hazardous Noise

 <b>CAUTION</b>	<b>Hazardous noise. Can cause hearing loss.</b>
	Never operate the generator set without a muffler or with a faulty exhaust system.

**Engine noise. Hazardous noise can cause hearing loss.** Generator sets not equipped with sound enclosures can produce noise levels greater than 105 dBA. Prolonged exposure to noise levels greater than 85 dBA can cause permanent hearing loss. Wear hearing protection when near an operating generator set.

## Hazardous Voltage/Moving Parts

 <b>DANGER</b>	<b>Hazardous voltage.</b> <b>Will cause severe injury or death.</b>
	This equipment must be installed and serviced by qualified electrical personnel.
 <b>DANGER</b>	<b>Hazardous voltage. Moving parts.</b> <b>Will cause severe injury or death.</b>
 	Operate the generator set only when all guards and electrical enclosures are in place.
 <b>WARNING</b>	<b>Hazardous voltage. Backfeed to the utility system.</b> <b>Can cause property damage, severe injury, or death.</b>
	If the generator set is used for standby power, install an automatic transfer switch to prevent inadvertent interconnection of standby and normal sources of supply.
 <b>CAUTION</b>	
<b>Welding the generator set.</b> <b>Can cause severe electrical equipment damage.</b> Welding on generator set will cause serious damage to engine electronic controls components. Disconnect all engine electronic control connections before welding.	

**Grounding electrical equipment. Hazardous voltage will cause severe injury or death.** Electrocutation is possible whenever electricity is present. Ensure you comply with all applicable codes and standards. Electrically ground the generator set and related equipment and electrical circuits. Turn off the main circuit breakers of all power sources before servicing the equipment. Never contact electrical leads or appliances when standing in water or on wet ground because these conditions increase the risk of electrocution.



**Welding on the generator set. Can cause severe electrical equipment damage.** Before welding on the generator set perform the following steps: (1) Remove the battery cables, negative (-) lead first. (2) Disconnect all engine electronic control module (ECM) connectors. (3) Disconnect all generator set controller and voltage regulator circuit board connectors. (4) Disconnect the engine battery-charging alternator connections. (5) Attach the weld ground connection close to the weld location.

**Connecting the battery and the battery charger. Hazardous voltage will cause severe injury or death.** Reconnect the battery correctly, positive to positive and negative to negative, to avoid electrical shock and damage to the battery charger and battery(ies). Have a qualified electrician install the battery(ies).



**Short circuits. Hazardous voltage/current will cause severe injury or death.** Short circuits can cause bodily injury and/or equipment damage. Do not contact electrical connections with tools or jewelry while making adjustments or repairs. Remove all jewelry before servicing the equipment.

**Electrical backfeed to the utility. Hazardous backfeed voltage can cause severe injury or death.** Install a transfer switch in standby power installations to prevent the connection of standby and other sources of power. Electrical backfeed into a utility electrical system can cause severe injury or death to utility personnel working on power lines.



## Heavy Equipment

 <b>WARNING</b>	<b>Unbalanced weight.</b> <b>Improper lifting can cause severe injury or death and equipment damage.</b> Do not use lifting eyes. Lift the generator set using lifting bars inserted through the lifting holes on the skid.
	

## Moving Parts

 <b>WARNING</b>	<b>Airborne particles.</b> <b>Can cause severe injury or blindness.</b> Wear protective goggles and clothing when using power tools, hand tools, or compressed air.
	

## Hot Parts

 <b>WARNING</b>	<b>Hot engine and exhaust system.</b> <b>Can cause severe injury or death.</b> Do not work on the generator set until it cools.
	

**Servicing the exhaust system. Hot parts can cause severe injury or death.** Do not touch hot engine parts. The engine and exhaust system components become extremely hot during operation.

**Servicing the engine heater. Hot parts can cause minor personal injury or property damage.** Install the heater before connecting it to power. Operating the heater before installation can cause burns and component damage. Disconnect power to the heater and allow it to cool before servicing the heater or nearby parts.

## NOTICE

**Canadian installations only.** For standby service connect the output of the generator set to a suitably rated transfer switch in accordance with Canadian Electrical Code, Part 1.

This manual provides installation instructions for the Model 12RES generator set.

**Kohler strongly recommends that only factory-authorized distributors or dealers install and service the generator.**

Have an authorized distributor/dealer install the generator set outdoors according to the instructions in this manual. The generator set installation must comply with the National Electrical Code® (NEC) and local code requirements. Do not install this generator set indoors.

Information in this publication represents data available at the time of print. Discovery Energy, LLC reserves the right to change this publication and the products represented without notice and without any obligation or liability whatsoever.

Read this manual and carefully follow all procedures and safety precautions to ensure proper equipment operation and to avoid bodily injury. Read and follow the Safety Precautions and Instructions section at the beginning of this manual.

The generator set is shown in Figure 1. See the dimension drawing in the Dimension Drawings and Wiring Diagrams section for generator set component locations.



Figure 1 Model 12RES Generator Set

## List of Related Literature

Figure 2 identifies related literature available for the generator sets covered in this manual. Only trained and qualified personnel should install or service the generator set.

Literature Type	Part Number
Specification Sheet, 12RES	G4-248
Operation Manual, Generator Set	TP-6515
Service Manual, Generator Set	TP-6196
Service Manual, Engine	24 690 06
Parts Catalog	TP-5868
Operation Manual, OnCue® for ADC	TP-6616

Figure 2 Related Literature

## Startup Notification

Complete the startup and installation checklists supplied with the startup notification form. Complete and sign the startup notification form and register the unit using the Kohler online Warranty Processing System.

For professional advice and conscientious service, please contact your nearest authorized distributor or dealer.

- Visit the company website at [kohlergenerators.com](http://kohlergenerators.com).
- Look at the labels and decals on your product or review the appropriate literature or documents included with the product.
- Call toll free in the US and Canada 1-800-544-2444.
- Outside the US and Canada, call the nearest regional office.

## **Headquarters Europe, Middle East, Africa (EMEA)**

EMEA Headquarters  
Netherlands B.V.  
Kristallaan 1  
4761 ZC Zevenbergen  
The Netherlands  
Phone: (31) 168 331630  
Fax: (31) 168 331631

## **Asia Pacific**

Asia Pacific Headquarters  
Singapore, Republic of Singapore  
Phone: (65) 6264-6422  
Fax: (65) 6264-6455

## **China**

North China Regional Office, Beijing  
Phone: (86) 10 6518 7950  
(86) 10 6518 7951  
(86) 10 6518 7952  
Fax: (86) 10 6518 7955

East China Regional Office, Shanghai  
Phone: (86) 21 6288 0500  
Fax: (86) 21 6288 0550





## **India, Bangladesh, Sri Lanka**

India Regional Office  
Bangalore, India  
Phone: (91) 80 3366208  
(91) 80 3366231  
Fax: (91) 80 3315972

## **Japan, Korea**

North Asia Regional Office  
Tokyo, Japan  
Phone: (813) 3440-4515  
Fax: (813) 3440-2727

## 1.1 Introduction

 <b>DANGER</b>	<p><b>Hazardous voltage.</b> <b>Will cause severe injury or death.</b></p> <p>This equipment must be installed and serviced by qualified electrical personnel.</p>
	
 <b>WARNING</b>	<p><b>Carbon monoxide.</b> <b>Can cause severe nausea, fainting, or death.</b></p> <p>The exhaust system must be leakproof and routinely inspected.</p>
	

**Generator set operation. Carbon monoxide can cause severe nausea, fainting, or death.** Carbon monoxide is an odorless, colorless, tasteless, nonirritating gas that can cause death if inhaled for even a short time. Avoid breathing exhaust fumes when working on or near the generator set. Never operate the generator set inside a building. Never operate the generator set where exhaust gas could seep inside or be drawn into a potentially occupied building through windows, air intake vents, or other openings.

**Carbon monoxide detectors. Carbon monoxide can cause severe nausea, fainting, or death.** Install carbon monoxide detectors on each level of any building adjacent to the generator set. Locate the detectors to adequately warn the building's occupants of the presence of carbon monoxide. Keep the detectors operational at all times. Periodically test and replace the carbon monoxide detectors according to the manufacturer's instructions.

Have the generator set installed by an authorized distributor/dealer. For all locations, ensure that the installation complies with applicable national and local codes. In the United States, the installation must comply with the National Electrical Code (NEC) and all applicable state and local codes. For Canadian installations, refer to the Canadian Electrical Code (CEC).

The generator set must be installed outdoors. The exhaust systems on enclosed units are designed for outdoor installation only.

**Note:**

**DO NOT** install these generator sets inside a building.

**Note:**



Install carbon monoxide (CO) detector(s) on each level of any building adjacent to a generator set. Locate the detectors to adequately warn the building's occupants of the presence of carbon monoxide.

Obtain a building permit and contact your local utility companies to mark the locations of underground pipes and cables.

Read and follow the safety precautions in this manual and observe the decals on the equipment. Refer to the diagrams and drawings in this manual for dimensions and electrical connections during the installation procedure. Read the entire installation procedure and obtain the accessories and tools needed before beginning installation. Perform the steps in the order shown.

To install optional accessories, follow the instructions provided with each kit.

## 1.2 Lifting

 <b>WARNING</b>	<b>Unbalanced weight.</b> <b>Improper lifting can cause severe injury or death and equipment damage.</b> Do not use lifting eyes. Lift the generator set using lifting bars inserted through the lifting holes on the skid.
	

Model	Weight, kg (lb.)
12RES	186 (410)

Figure 3 Approximate Weight

The approximate generator set weight is shown in Figure 3. Use lifting bars inserted through the holes in the skid to lift the unit. See the dimension drawings in the Dimension Drawings and Wiring Diagrams section for lifting hole locations.

## 1.3 Generator Set Inspection

Complete a thorough inspection of the generator set. Check for the following:

1. Inspect the generator set for loose or damaged parts or wires. Repair or tighten any loose parts before installation.
2. Check the engine oil. Fill, if necessary, with the recommended viscosity and grade of oil. Use synthetic oil, API (American Petroleum Institute) Service Class SG or higher. See TP-6515, Operation Manual, for additional information.

## 1.4 Location and Mounting

Install the generator set outdoors near the incoming gas service. The generator set location must allow easy access for maintenance and service. The required distance from a structure is dependent on state or province and local codes. See the dimension drawing in the Dimension Drawings and Wiring Diagrams section for the minimum clearance from structures and non-combustible materials.

Locate the generator set so that the hot exhaust does not blow on plants or other combustible materials. No plants, shrubs, or other combustible materials are allowed within 1.2 m (4 ft.) of the exhaust end of the generator set.

Do not install the generator set where exhaust gas could accumulate and seep inside or be drawn into a potentially occupied building. Furnace and other similar intakes must be at least 3 m (10 ft.) from the exhaust end of the generator set.

### Notice



**DO NOT** locate the generator set near patios, decks, play areas, or animal shelters. Keep items such as lawn furniture, toys, sports equipment, and all combustible materials away from the generator set exhaust outlet.

Remind family members, children, and visitors to use caution near the generator set. Generator sets connected to automatic transfer switches start automatically during exercise periods and power outages. Some generator set components become hot when the generator set is running and remain hot for a time after the generator set shuts down.

The generator set is shipped on a plastic mounting pad. Prepare a flat, level mounting area covered with a weed barrier and gravel or a concrete pad as shown in the generator set clearance drawing. Set the plastic mounting pad directly on the gravel or concrete. Do not install the mounting pad directly on grass.

See the dimension drawings in the Dimension Drawings and Wiring Diagrams section for special mounting instructions for high wind (150 MPH) areas.

### 1.4.1 Exhaust Requirements

 <b>WARNING</b>	<b>Carbon monoxide.</b> <b>Can cause severe nausea, fainting, or death.</b> The exhaust system must be leakproof and routinely inspected.
	

**Generator set operation. Carbon monoxide can cause severe nausea, fainting, or death.** Carbon monoxide is an odorless, colorless, tasteless, nonirritating gas that can cause death if inhaled for even a short time. Avoid breathing exhaust fumes when working on or near the generator set. Never operate the generator set inside a building. Never operate the generator set where exhaust gas could seep inside or be drawn into a potentially occupied building through windows, air intake vents, or other openings.

The exhaust system is designed for generator sets installed outdoors. Do not install this generator set indoors.

Figure 1 gives the exhaust flow and temperature at rated load. The engine exhaust mixes with the generator set cooling air at the exhaust end of the enclosure. Mount the generator set so that the hot exhaust does not blow on plants or other combustible materials. Maintain the clearances shown in the dimension drawings in the Dimension Drawings and Wiring Diagrams section.

Exhaust System	60 Hz	50 Hz
Exhaust flow at rated kW, m <sup>3</sup> /min. (cfm)	3.8 (135)	3.2 (113)
Exhaust gas exiting the enclosure at rated kW, °C (°F)	216 (420)	

Figure 4 Exhaust Flow and Temperature

### 1.4.2 Air Requirements

The generator set requires correct air flow for cooling and combustion. The inlet and outlet openings in the sound enclosure provide the cooling and combustion air. Figure 5 shows the locations of the cooling air intake and exhaust vents. Inspect the air inlet and outlet openings inside and outside the housing to ensure that the air flow is not blocked.

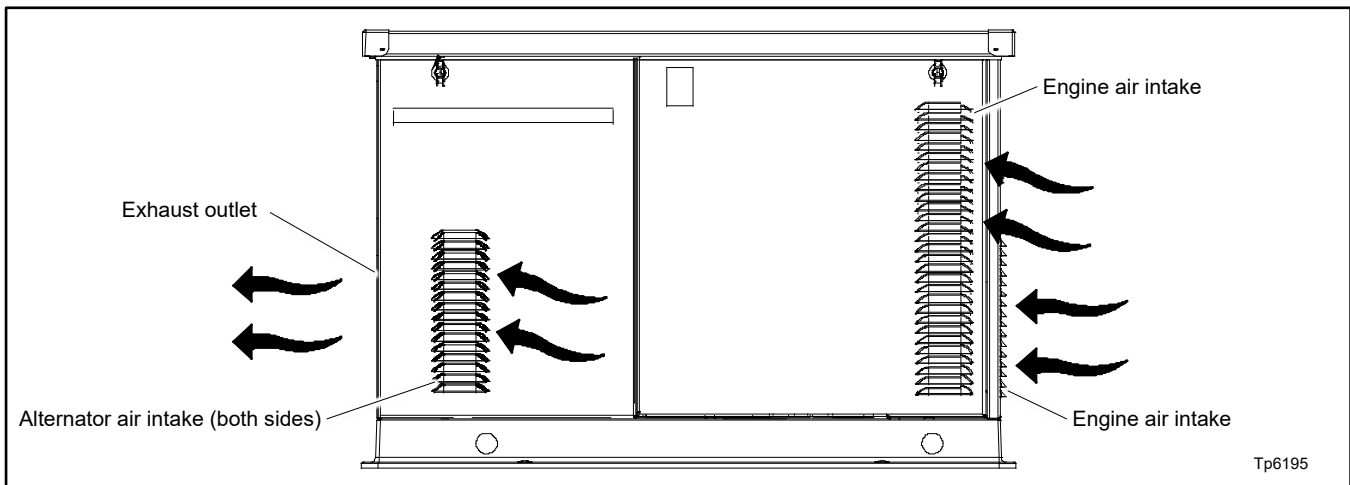

Figure 5 Cooling Air Intake and Exhaust, Typical

Air Requirements, m <sup>3</sup> /min. (cfm)				
Model	Hz	Cooling Air	Combustion Air	Total Inlet Air
12RES	60	26.9 (950)	1.1 (39.2)	28.0 (990)
	50	22.4 (790)	0.9 (32.6)	23.4 (825)

Figure 6 Air Requirements

## 1.5 Power Supply

Power must be supplied from a source that is GFCI protected to the generator set location for the battery charger and the optional accessories shown in Figure 7.

Connect power from a circuit on the essential loads panel to the utility power connection points on the terminal block. The circuit must be backed up by the generator set. See the Electrical Connections section and the wiring diagrams in the Dimension Drawings and Wiring Diagrams section for connection details. See Figure 7 for the power requirements for the battery charger and accessories.



Equipment	Power Requirement, Max.		
	Watts	Amps	Volts
Battery charger (standard)	192	1.6	120
Carburetor heater (optional)	37	0.33	
Battery heater	110	0.92	

Figure 7 Power Requirements

## 1.6 Fuel Requirements

The generator set operates using natural gas or LPG fuel. The generator set is EPA-certified for both natural gas and LPG fuels.

The fuel system installation must comply with applicable national, state, and local codes.

 <b>WARNING</b>	<p><b>Explosive fuel vapors.</b>  <b>Can cause severe injury or death.</b>            Use extreme care when handling, storing, and using fuels.</p>
 	

**Gas fuel leaks. Explosive fuel vapors can cause severe injury or death.** Fuel leakage can cause an explosion. Check the LPG vapor or natural gas fuel system for leakage by using a soap and water solution with the fuel system test pressurized to 6–8 ounces per square inch (10–14 inches water column). Do not use a soap solution containing either ammonia or chlorine because both prevent bubble formation. A successful test depends on the ability of the solution to bubble.

**The fuel system. Explosive fuel vapors can cause severe injury or death.** Vaporized fuels are highly explosive. Use extreme care when handling and storing fuels. Store fuels in a well-ventilated area away from spark-producing equipment and out of the reach of children. Never add fuel to the tank while the engine is running because spilled fuel may ignite on contact with hot parts or from sparks. Do not smoke or permit flames or sparks to occur near sources of spilled fuel or fuel vapors. Keep the fuel lines and connections tight and in good condition. Do not replace flexible fuel lines with rigid lines. Use flexible sections to avoid fuel line breakage caused by vibration. Do not operate the generator set in the presence of fuel leaks, fuel accumulation, or sparks. Repair fuel systems before resuming generator set operation.

### 1.6.1 Fuel Supply

Because of variable climates and geographical considerations, contact the local fuel supplier for fuel system planning and installation. Figure 1 lists the recommended fuel ratings and other fuel supply information for natural gas and LPG fuels.

Fuel Type	Natural Gas	LPG
Fuel supply inlet	1/2 NPT	
Fuel supply pressure, kPa (in. H <sub>2</sub> O)	0.9-2.7 (3.5-11)	1.7-2.7 (7-11)
Fuel flow rate, Btu/hr.	193000	203000
Nominal Fuel Rating, Btu/ft. <sup>3</sup>	1000	2500

Figure 8 Fuel Supply

Verify that the output pressure from the primary gas utility (or LPG tank) pressure regulator meets the specifications in Figure 1 and that the utility gas meter flow rate is sufficient to supply the generator set at rated load plus all other gas-consuming appliances. See Figure 2 for fuel consumption. Contact the fuel supplier for flow rate information or a gas meter upgrade.

The dimension drawings in the Dimension Drawings and Wiring Diagrams section show the location of the fuel inlet connection. Use flexible sections to prevent fuel line breakage caused by vibration. Hold the fuel pipe coupling with a wrench when tightening the fuel connections. Protect all fuel lines from machinery or equipment contact, adverse weather conditions, and environmental damage.

Fuel Consumption, at % load, m <sup>3</sup> /hr. (cfh)	60 Hz	50 Hz
Natural Gas, m <sup>3</sup> /hr. (cfh)		
100%	5.4 (193)	4.8 (173)
75%	4.7 (163)	4.2 (148)
50%	3.5 (124)	3.1 (108)
25%	2.6 (93)	2.4 (84)
LPG, m <sup>3</sup> /hr. (cfh)		
100%	2.3 (81)	2.1 (74)
75%	2.1 (75)	1.9 (68)
50%	1.8 (60)	1.5 (53)
25%	1.2 (45)	1.1 (40)
LPG conversion factors: 8.58 ft. <sup>3</sup> = 1 lb. 0.535 m <sup>3</sup> = 1 kg 36.39 ft. <sup>3</sup> = 1 gal.		
Nominal fuel rating: Natural gas: 37 MJ/m <sup>3</sup> (1000 Btu/ft. <sup>3</sup> ) LPG: 93 MJ/m <sup>3</sup> (2500 Btu/ft. <sup>3</sup> )		

Figure 9 Fuel Consumption

### 1.6.2 Fuel Pipe Size

Ensure that the fuel pipe size and length meet the specifications in Figure 1. Measure the pipe length from the primary gas pressure regulator to the pipe connection on the generator set fuel inlet. Add 2.4 m (8 ft.) to the measured length for each 90-degree elbow. Compare the total pipe length with the chart in Figure 1 to find the required pipe size.

Contact the local LPG provider for LPG installation information.

Minimum Gas Pipe Size Recommendation, in. NPT		
Pipe Length, m (ft.)	Natural Gas (193,000 Btu/hr.)	LPG (203,000 Btu/hr.)
8 (25)	3/4	3/4
15 (50)	1	3/4
30 (100)	1	1
46 (150)	1 1/4	1
61 (200)	1 1/4	1

Figure 10 Fuel Pipe Size

## 1.7 Fuel Conversion

The multi-fuel system allows conversion from natural gas to LPG (or vice-versa) in the field while maintaining emissions-standard compliance. A authorized distributor/dealer can convert the fuel system.

A revised fuel system was implemented in February, 2021. The fuel system can be identified by comparing the regulator and solenoid valve with the illustrations in the following sections.

The original fuel system uses fuel orifice fittings to control the fuel flow for natural gas (NG) or LPG fuels. The original system uses a fuel regulator and a separate fuel solenoid valve. See the Fuel Conversion, Original Fuel System section for illustrations and instructions to convert the fuel on generator sets with the original design.



The revised fuel system uses a fuel regulator with a fuel selector valve and an integrated fuel solenoid valve. See the Fuel Conversion, Revised Fuel System section for illustrations and instructions to convert the fuel on generator sets with the revised fuel system.

### Rating Change



Converting the fuel will change the generator set rating. See the generator set specification sheet for ratings with natural gas and LPG. Order a new nameplate with the updated rating and fuel information from a authorized distributor/dealer, if necessary. Provide the following information from the original nameplate:

- Model Number
- Spec Number
- Serial Number
- Fuel (original and new)
- kW
- kVA
- Amps
- Volts
- Hz

Attach the new nameplate over the old one. Do NOT cover the UL listing information on the old nameplate.

 <b>WARNING</b>	<p><b>Accidental starting.</b> <b>Can cause severe injury or death.</b></p> <p>Disconnect the battery cables before working on the generator set. Remove the negative (-) lead first when disconnecting the battery. Reconnect the negative (-) lead last when reconnecting the battery.</p>
	

**Disabling the generator set. Accidental starting can cause severe injury or death.** Before working on the generator set or equipment connected to the set, disable the generator set as follows: (1) Move the generator set master switch to the OFF position. (2) Disconnect the power to the battery charger. (3) Remove the battery cables, negative (-) lead first. Reconnect the negative (-) lead last when reconnecting the battery. Follow these precautions to prevent starting of the generator set by an automatic transfer switch, remote start/stop switch, or engine start command from a remote computer.

 <b>WARNING</b>	<p><b>Explosive fuel vapors.</b> <b>Can cause severe injury or death.</b></p> <p>Use extreme care when handling, storing, and using fuels.</p>
	

### 1.7.1 Fuel Conversion, Original Fuel System

For natural gas and LPG fuel, orifice fittings are used in the fuel line. See Figure 1. The natural gas orifice fitting is silver in color and stamped NG. The LPG fitting is gold in color and stamped LPG. The fittings are threaded. A straight-blade screwdriver is required to remove and replace the fittings.



Figure 11 NG and LPG Fuel Orifice Fittings

The unit is typically shipped set up for natural gas, with the LPG fitting tied to the fuel regulator. To convert to LPG, remove the NG fitting and install the LPG fitting as described below. See Figure 2 for the fuel system component locations.

#### Procedure to Convert from NG to LPG

1. Place the generator set master switch in the OFF/RESET position.
2. Disconnect the utility power to the generator.
3. Disconnect the generator set engine starting battery, negative (-) lead first.
4. Turn off and disconnect the fuel supply.
5. Remove the hose clamp and fuel hose from the hose fitting. See Figure 2.
6. Use a straight-blade screwdriver to remove the NG orifice from the hose fitting. See Figure 3.
7. Insert the LPG orifice into the hose fitting. Use a straight-blade screwdriver to tighten the fitting until it is snug.
8. Slide the hose onto the hose fitting and secure it with the clamp.
9. Disconnect ignition timing leads 65 and N5 for LPG. The ignition timing leads are located near the fuel solenoid valve. See Figure 2.

**Note:**

Do not disconnect the leads to the fuel solenoid valve.

10. Connect and turn on the new fuel supply.
11. Reconnect the generator set engine starting battery leads, negative (-) lead last.
12. Reconnect the utility power to the generator.
13. Start the generator set by moving the master switch to the RUN position.
14. Check for leaks using a gas leak detector.
15. Run the generator set and check the operation.
16. Move the generator set master switch to the OFF/RESET position to shut down the generator set.

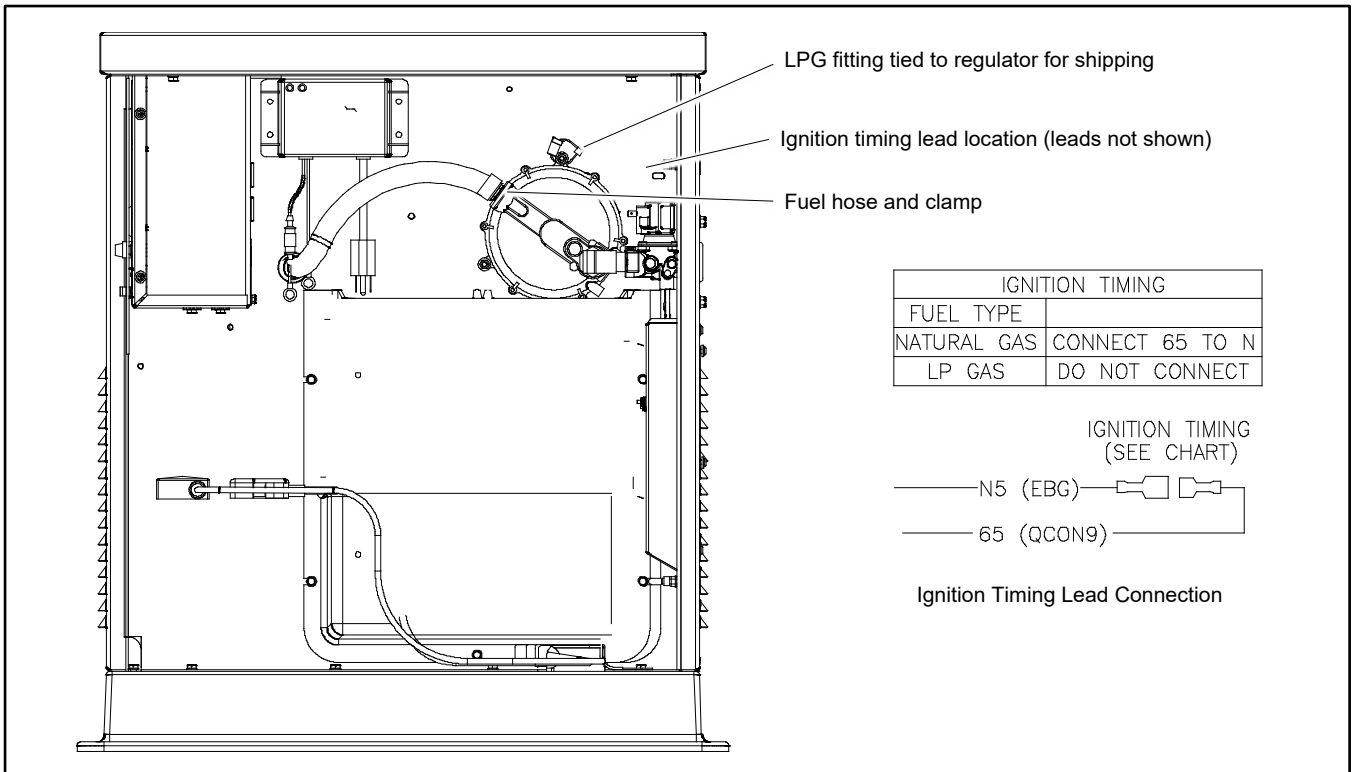

Figure 12 Fuel System, As Shipped

**Conversion from LPG to Natural Gas**

To convert from LPG to natural gas, repeat the steps above, removing the LPG fuel orifice and installing the NG fitting. Connect ignition timing leads 65 and N5 together for natural gas.

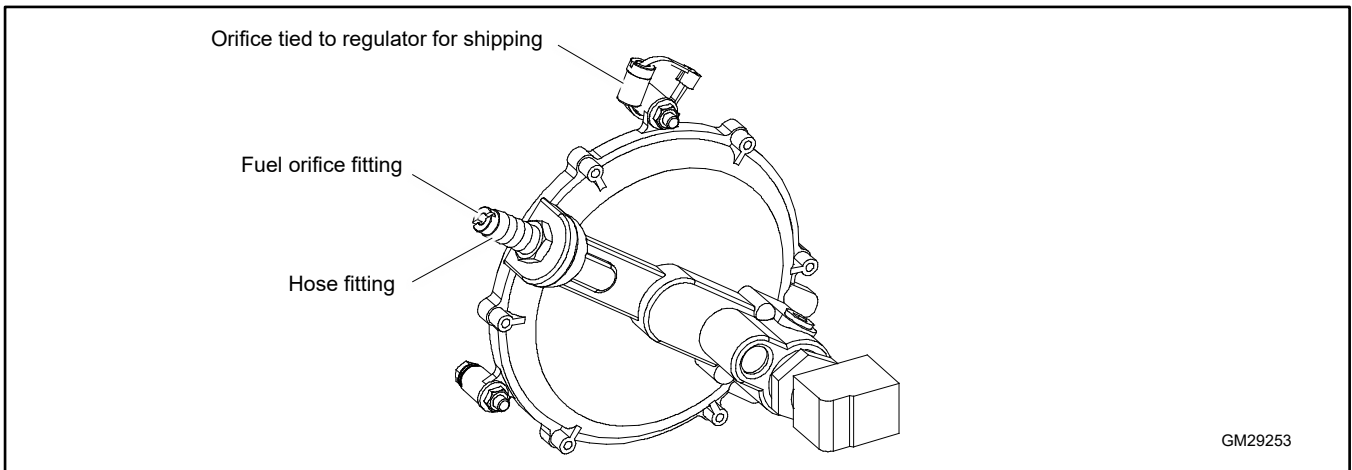

Figure 13 Fuel Orifice Fitting Installation

## 1.7.2 Fuel Conversion, Revised Fuel System

The revised fuel system uses a knob that controls a valve on the regulator to select the fuel type. See Figure 1 and Figure 2.

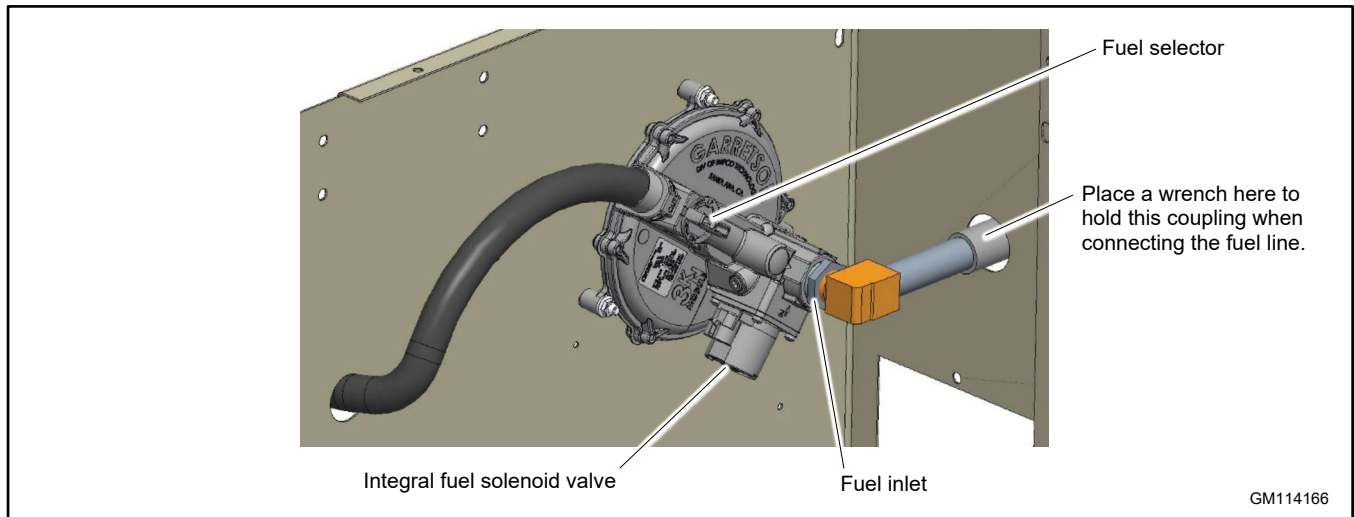

Figure 14 Revised Fuel System

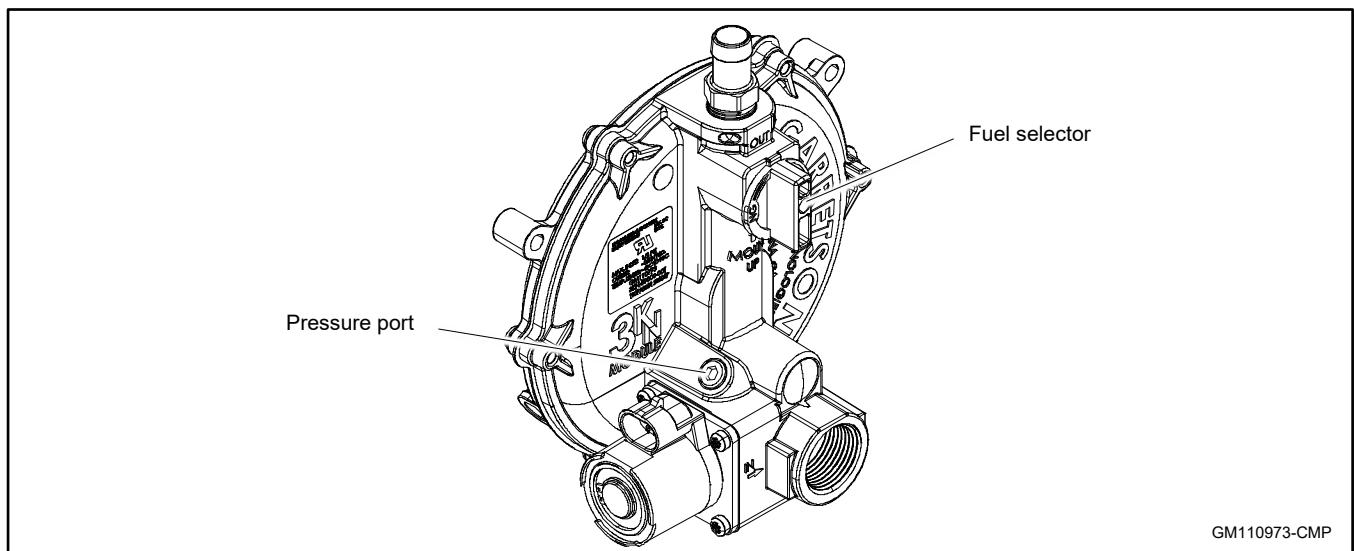

Figure 15 Fuel Selection (NG Position Shown)

### Fuel Selection, Revised Fuel System

1. Place the generator set master switch in the OFF/RESET position.
2. Disconnect the utility power to the generator.
3. Disconnect the generator set engine starting battery, negative (-) lead first.
4. Turn off and disconnect the fuel supply.
5. To change the fuel selection:
  - a. For natural gas (NG), turn the selection knob all the way clockwise. The knob lines up with the UP arrow on the regulator body as shown in Figure 3.



Figure 16 Knob Position, NG

- b. For LPG, turn the selection knob counterclockwise as far as it will go, approximately ¼ turn. See Figure 4.



Figure 17 Knob Position, LPG

6. Find the ignition timing leads 65 and N, located near the regulator. See Figure 5.
  - a. For natural gas (NG), connect lead 65 to lead N.
  - b. For LPG, disconnect lead 65 from lead N.
7. Connect and turn on the fuel supply (Ensure that the fuel supply matches the fuel setting).
8. Reconnect the generator set engine starting battery leads, negative (-) lead last.
9. Reconnect the utility power to the generator.
10. Start the generator set by moving the master switch to the RUN position.
11. Check for leaks using a gas leak detector.
12. Run the generator set and check the operation.
13. Move the generator set master switch to the OFF/RESET position to shut down the generator set.

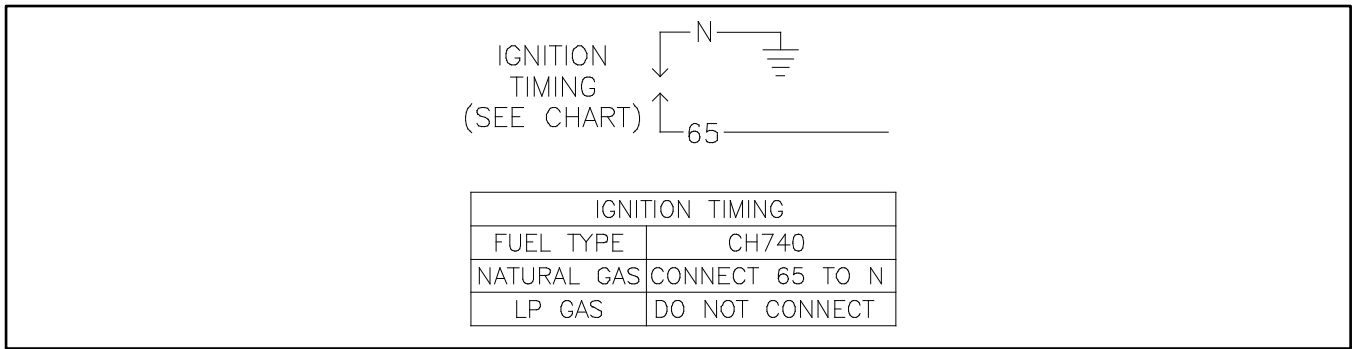



Figure 18 Ignition Timing Leads

**Pressure Port**

A pressure port is provided on the fuel regulator. See Figure 2. Follow these steps to check the fuel pressure at the regulator, if necessary.

1. Remove the plug from the fuel pressure port.
2. Connect a manometer capable of measuring low pressures (3-11 inches water column) to the pressure port.
3. When finished, replace the plug in the pressure port and check for leaks.

## 1.8 Electrical Connections

 <b>WARNING</b>	<p><b>Hazardous voltage. Backfeed to the utility system.</b>  <b>Can cause property damage, severe injury, or death.</b></p> <p>If the generator set is used for standby power, install an automatic transfer switch to prevent inadvertent interconnection of standby and normal sources of supply.</p>
	

**Grounding electrical equipment. Hazardous voltage will cause severe injury or death.** Electrocutation is possible whenever electricity is present. Ensure you comply with all applicable codes and standards. Electrically ground the generator set and related equipment and electrical circuits. Turn off the main circuit breakers of all power sources before servicing the equipment. Never contact electrical leads or appliances when standing in water or on wet ground because these conditions increase the risk of electrocution.

**Electrical backfeed to the utility. Hazardous backfeed voltage can cause severe injury or death.** Install a transfer switch in standby power installations to prevent the connection of standby and other sources of power. Electrical backfeed into a utility electrical system can cause severe injury or death to utility personnel working on power lines.

### NOTICE

**Canadian installations only.** For standby service connect the output of the generator set to a suitably rated transfer switch in accordance with Canadian Electrical Code, Part 1.

Have a authorized distributor/dealer or a licensed electrician make the following electrical connections. The electrical installation must comply with the National Electrical Code (NEC) and all applicable local codes. Canadian installations must comply with the Canadian Electrical Code (CEC) and applicable local codes.

Ground the generator set according to applicable codes. See the Grounding section.

For customer-supplied wiring, select the wire temperature rating in Figure 1 based upon the following criteria:

- Select row 1, 2, 3, or 4 if the circuit rating is 110 amperes or less or requires #1 AWG (42.4 mm<sup>2</sup>) or smaller conductors.
- Select row 3 or 4 if the circuit rating is greater than 110 amperes or requires #1 AWG (42.4 mm<sup>2</sup>) or larger conductors.

Row	Temp. Rating	Copper (Cu) Only	Cu/Aluminum (Al) Combinations	Al Only
1	60°C (140°F) or 75°C (167°F)	Use No. * AWG, 60°C wire or use No. * AWG, 75°C wire	Use 60°C wire, either No. * AWG Cu, or No. * AWG Al or use 75°C wire, either No. * AWG Cu or No. * AWG Al	Use 60°C wire, No.* AWG or use 75°C wire, No. * AWG
2	60°C (140°F)	Use No. * AWG, 60°C wire	Use 60°C wire, either No. * AWG Cu or No. * AWG Al	Use 60°C wire, No.* AWG
3	75°C (167°F)	Use No. *† AWG, 75°C wire	Use 75°C wire, either No. *† AWG Cu or No. *† AWG Al	Use 75°C wire, No.* † AWG
4	90°C (194°F)	Use No. *† AWG, 90°C wire	Use 90°C wire, either No. *† AWG Cu or No. *† AWG Al	Use 90°C wire, No.* † AWG

\* The wire size for 60°C (140°F) wire is not required to be included in the marking. If included, the wire size is based on ampacities for the wire given in Table 310-16 of the National Electrical Code®, in ANSI/NFPA 70, and on 115% of the maximum current that the circuit carries under rated conditions. The National Electrical Code® is a registered trademark of the National Fire Protection Association, Inc.  
† Use the larger of the following conductors: the same size conductor as that used for the temperature test or one selected using the guidelines in the preceding footnote.

Figure 19 Terminal Markings for Various Temperature Ratings and Conductors

## 1.8.1 Field Connections

The generator set is equipped with a field-connection terminal block located below the fuel inlet. Leads have been factory-installed from the junction box to the terminal block for easy field wiring. Refer to the decal near the terminal block for connections. Also see the Dimension Drawings and Wiring Diagrams section.

Refer to the decal below the terminal block and the transfer switch specifications for the cable size range for each connection. Route leads through flexible conduit. Use separate conduit for AC wiring and low-voltage engine start leads. Ensure that the leads and conduit do not interfere with the operation of the generator set or obstruct the service areas.

### Field Connections to the Terminal Block

1. Remove the cover from the electrical connection access area. See Figure 20.
2. Drill holes for conduit fittings:
  - a. See Figure 20 for the electrical inlet location. Remove the cover from the electrical inlet area.
  - b. Drill holes in the cover for the conduit fittings and replace the cover. Use separate conduit for AC wiring and low-voltage engine start leads.
  - c. Feed the cables through the openings.

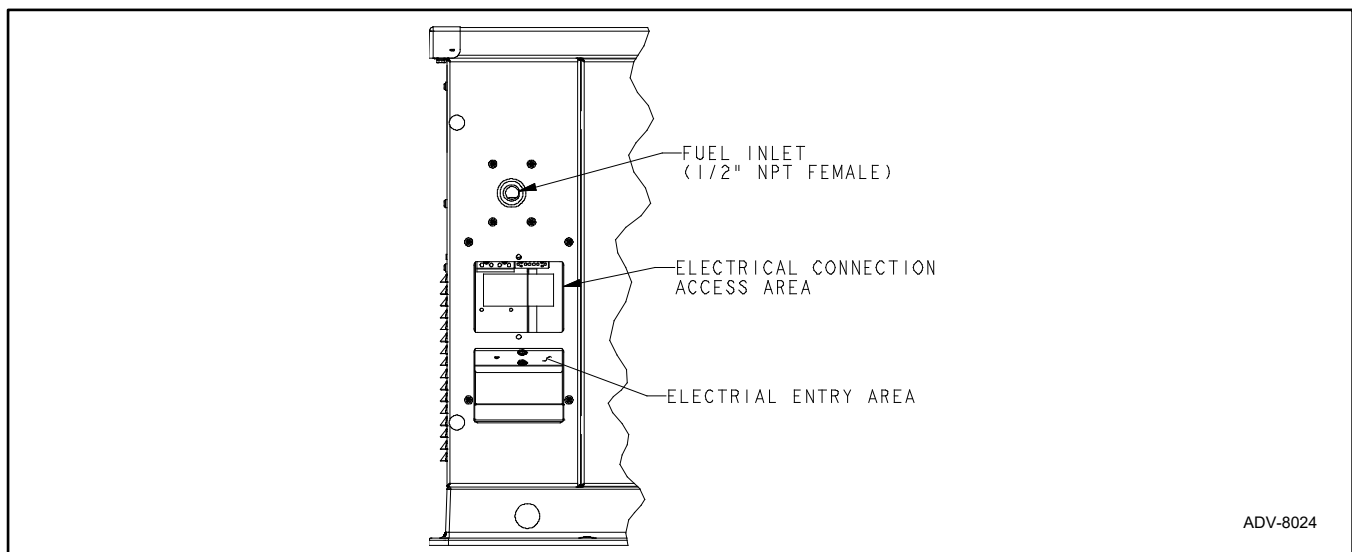

Figure 20 Electrical Connection Area

3. See Figure 21. Connect the leads from the transfer switch emergency source lugs to the L1 and L2 connections on the generator set terminal block.
4. Connect the neutral (L0) and ground (GRD) leads from the ATS and the main panel to the corresponding connection points on the terminal block. See the Grounding section.
5. Connect 120 VAC utility power to the terminals marked Utility Power. Power to this circuit must be backed-up by the generator set. See the Power Supply section for more information about the utility power requirement.
6. Connect the engine start leads from the automatic transfer switch or remote start switch to terminals 3 and 4 on the terminal block. See the Remote Start Connection section.
7. Replace the cover over the electrical connection access area. See Figure 20.

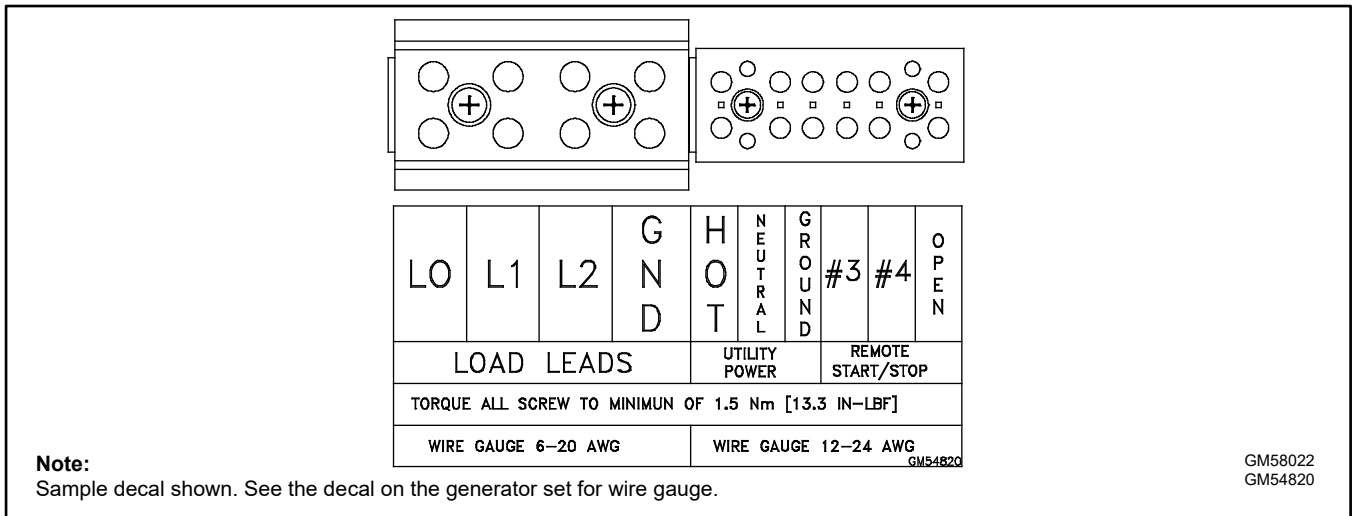

Figure 21 Field-Connection Terminal Block, typical

### 1.8.2 Remote Start Connection

Connect terminals 3 and 4 to the automatic transfer switch's engine start terminals or to an optional remote start/stop switch. Route the engine start leads through separate conduit from the AC power and load leads.

### 1.8.3 Grounding

Ground the generator set. The grounding method must comply with NEC and local codes. Connect the grounding cable to the generator set ground lug, terminal GND inside the controller compartment.

Generator sets are shipped with the generator neutral bonded (connected) to the generator ground in the junction box. The requirement for having a bonded (grounded) or ungrounded neutral is determined by the type of installation. At installation, the neutral can be grounded at the generator set or lifted from the ground stud and isolated if the installation requires an ungrounded neutral connection at the generator. The generator set will operate properly with the neutral either bonded to ground or isolated from ground at the generator.

Various regulations and site configurations including the National Electrical Code (NEC), local codes, and the type of transfer switch used in the application determine the grounding of the neutral at the generator. NEC Section 250 is one example that has a very good explanation of the neutral grounding requirements for generators.



### 1.8.4 Battery Charger



A battery charger is factory-installed in the battery compartment to keep the starting battery fully charged. The battery charger's DC leads are factory-connected to the battery. Supply power to the generator set for the battery charger and carburetor heater as described in the Power Supply and the Field Connections section.

Plug the battery charger's power cord into the receptacle on the bottom of the controller junction box.

Refer to the generator set operation manual for battery charger operation information.

## 1.9 Battery

 <b>WARNING</b>	<b>Sulfuric acid in batteries.</b> <b>Can cause severe injury or death.</b> Wear protective goggles and clothing. Battery acid may cause blindness and burn skin.
	



 <b>WARNING</b>	<b>Explosion.</b> <b>Can cause severe injury or death.</b> <b>Relays in the battery charger cause arcs or sparks.</b> Locate the battery in a well-ventilated area. Isolate the battery charger from explosive fumes.
	

**Battery electrolyte is a diluted sulfuric acid. Battery acid can cause severe injury or death.** Battery acid can cause blindness and burn skin. Always wear splashproof safety goggles, rubber gloves, and boots when servicing the battery. Do not open a sealed battery or mutilate the battery case. If battery acid splashes in the eyes or on the skin, immediately flush the affected area for 15 minutes with large quantities of clean water. Seek immediate medical aid in the case of eye contact. Never add acid to a battery after placing the battery in service, as this may result in hazardous spattering of battery acid.

**Battery acid cleanup. Battery acid can cause severe injury or death.** Battery acid is electrically conductive and corrosive. Add 500 g (1 lb.) of bicarbonate of soda (baking soda) to a container with 4 L (1 gal.) of water and mix the neutralizing solution. Pour the neutralizing solution on the spilled battery acid and continue to add the neutralizing solution to the spilled battery acid until all evidence of a chemical reaction (foaming) has ceased. Flush the resulting liquid with water and dry the area.

**Battery gases. Explosion can cause severe injury or death.** Battery gases can cause an explosion. Do not smoke or permit flames or sparks to occur near a battery at any time, particularly when it is charging. Do not dispose of a battery in a fire. To prevent burns and sparks that could cause an explosion, avoid touching the battery terminals with tools or other metal objects. Remove all jewelry before servicing the equipment. Discharge static electricity from your body before touching batteries by first touching a grounded metal surface away from the battery. To avoid sparks, do not disturb the battery charger connections while the battery is charging. Always turn the battery charger off before disconnecting the battery connections. Ventilate the compartments containing batteries to prevent accumulation of explosive gases.

**Battery short circuits. Explosion can cause severe injury or death.** Short circuits can cause bodily injury and/or equipment damage. Disconnect the battery before generator set installation or maintenance. Remove all jewelry before servicing the equipment. Use tools with insulated handles. Remove the negative (-) lead first when disconnecting the battery. Reconnect the negative (-) lead last when reconnecting the battery. Never connect the negative (-) battery cable to the positive (+) connection terminal of the starter solenoid. Do not test the battery condition by shorting the terminals together.

 <b>DANGER</b>	<b>Hazardous voltage.</b> <b>Will cause severe injury or death.</b> This equipment must be installed and serviced by qualified electrical personnel.
	

**Connecting the battery and the battery charger. Hazardous voltage will cause severe injury or death.** Reconnect the battery correctly, positive to positive and negative to negative, to avoid electrical shock and damage to the battery charger and battery(ies). Have a qualified electrician install the battery(ies).

Use a 12-volt group 26 battery with a minimum rating of 500 cold cranking amps at 0°F. The generator set uses a negative ground with a 12-volt engine electrical system. See Figure 22 for battery connections. Make sure that the battery is correctly connected and the terminals are tight.

**Note:**

The generator set will not start and circuit board damage may occur if the battery is connected in reverse.

Figure 23 shows the location of the engine starting battery. Standard battery cables provide easy connection to the battery. Use the following procedure to install and connect the battery.

**Battery Installation Procedure**

1. Ensure that the starting battery is fully charged before placing the battery in service.
2. Clean the battery posts and/or adapters, if necessary.
3. Install the battery post adapters, if needed.
4. Place the battery in the housing.
5. Verify that the controller master switch is in the OFF position.
6. Connect the positive (+) lead to the engine starting battery.
7. Connect the negative (-) lead to the engine starting battery.

Refer to the generator set operation manual and the battery manufacturer's instructions for battery maintenance instructions.

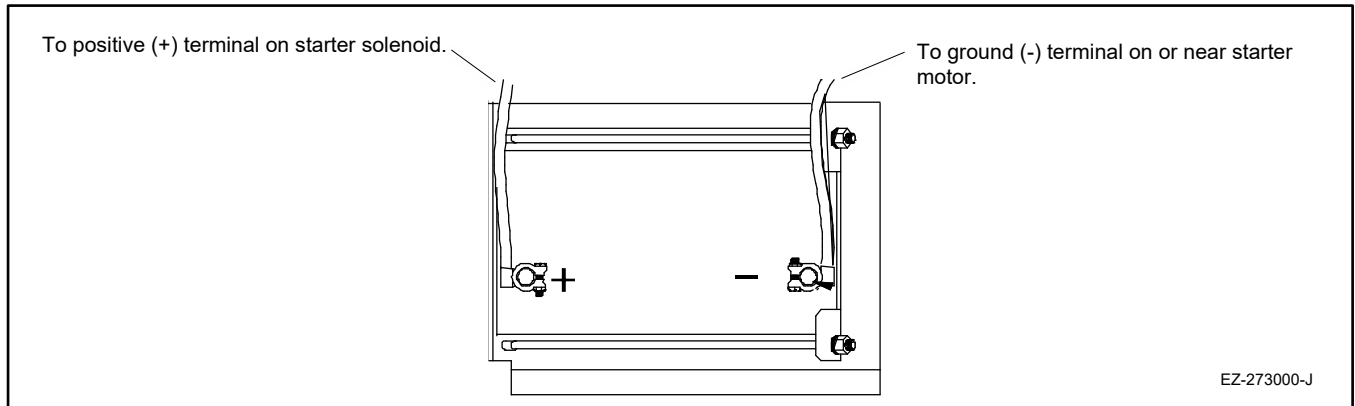

Figure 22 12-Volt Engine Electrical System Single Starter Motor Typical Battery Connection

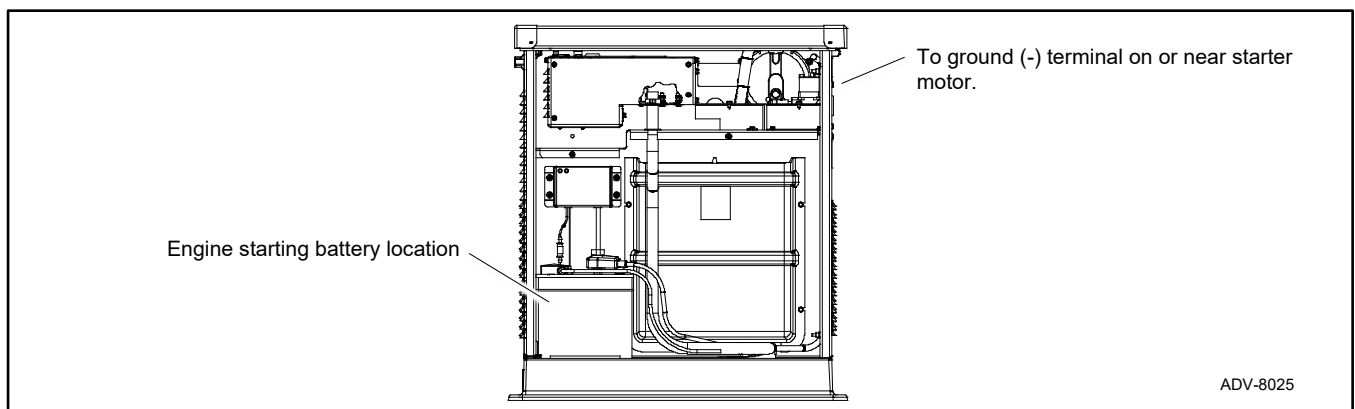

Figure 23 Battery Location, Air Intake End (typical)

## 1.10 Accessories

Have accessories installed by a authorized distributor/ dealer or a licensed electrician. Follow the installation instructions provided with each kit. Use separate conduit for AC and DC leads to reduce the possibility of electrical interference. Verify that the leads and conduit do not interfere with the operation of the generator set or obstruct the service areas. Verify that the electrical installation complies with the National Electrical Code (NEC) and all applicable local codes. See the Dimension Drawings and Wiring Diagrams section, for more information regarding generator set electrical connections.

If there are no accessories, proceed to the Prestart Installation Check section.

### 1.10.1 Common Fault and Auxiliary Run Relay Board

The optional relay board provides two additional relays to control customer-provided equipment:

- Common fault relay, energized on a fault.
- Auxiliary run relay, energized when the generator set is running.

See Figure 24 for the relay board location.

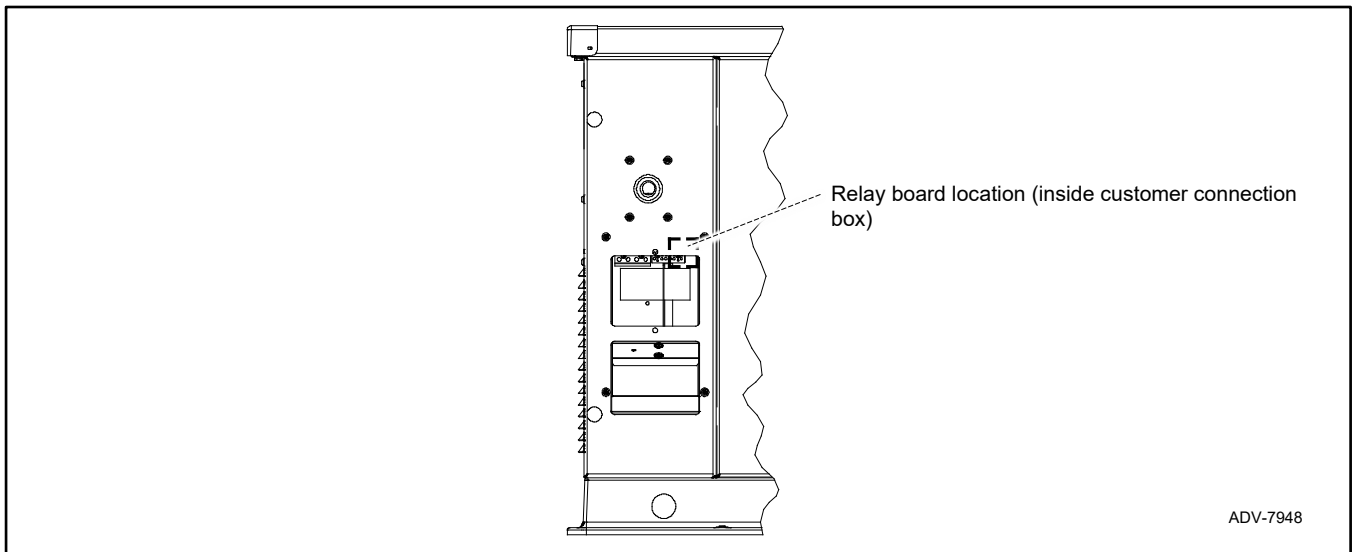

Figure 24 Optional Relay Board Location

Connect customer equipment to terminal strip TB1 on the relay board, following the markings on the board. Connect to each relay's normally open or normally closed contacts depending on the application. Use size 14 AWG maximum wire for connections to TB1. See Figure 25 and Figure 26.

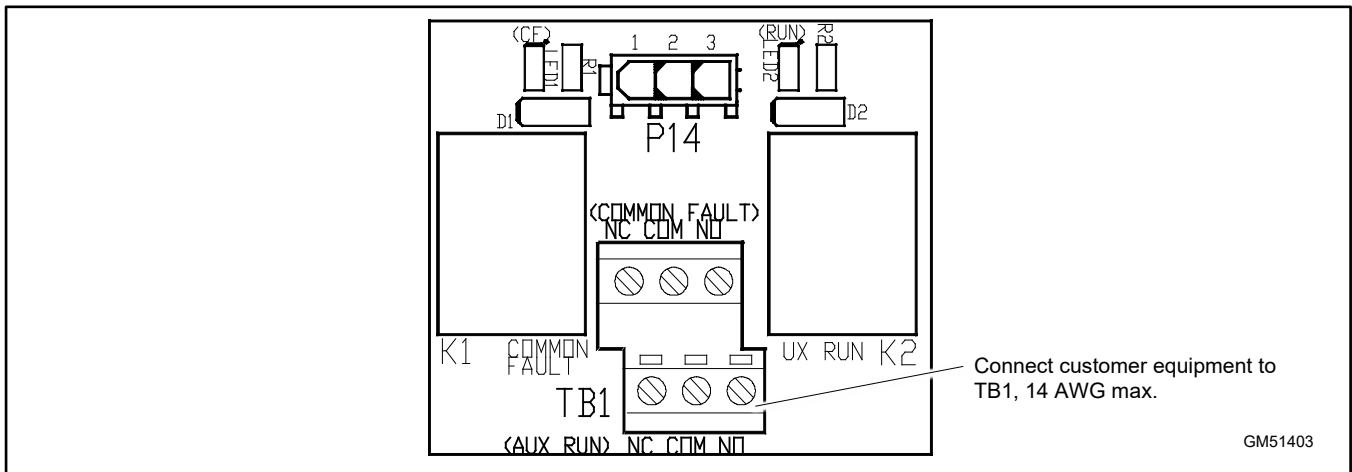

Figure 25 Relay Board Connections

Terminal Label	Description
COMMON FAULT NC	Common fault relay normally closed contact. Opens on a fault.
COMMON FAULT COM	Common fault relay common
COMMON FAULT NO	Common fault relay normally open contact. Closes on a fault.
AUX RUN NC	Auxiliary run relay normally closed contact. Open when generator set is running.
AUX RUN COM	Auxiliary run relay common
AUX RUN NO	Auxiliary run relay normally open contact. Closed when generator set is running.
<b>Note:</b> Use maximum 14 AWG wire for TB1 connections.	

Figure 26 Common Fault and Run Relay Board Harness Connections

### 1.10.2 Carburetor Heater

An optional carburetor heater is recommended for improved cold starting in locations where the ambient temperature drops below 0°C (32°F). The carburetor heater prevents condensation and carburetor icing. The heater turns on when the temperature at the thermostat falls below approximately 4°C (40°F) and turns off when the temperature rises above approximately 16°C (60°F). See Figure 27.

The carburetor heater thermostat is installed in the cord. Figure 28 shows the location of the thermostat on the power cord. The heater power cord and thermostat are located in the generator set housing air intake area/ battery compartment. See the Battery section.

**Note:**

Do not place the carburetor heater thermostat inside the generator set engine compartment. The thermostat must be exposed to the ambient air.

The heater requires a continuous source of power. Plug the carburetor heater into an outlet that supplies continuous 120 VAC power.

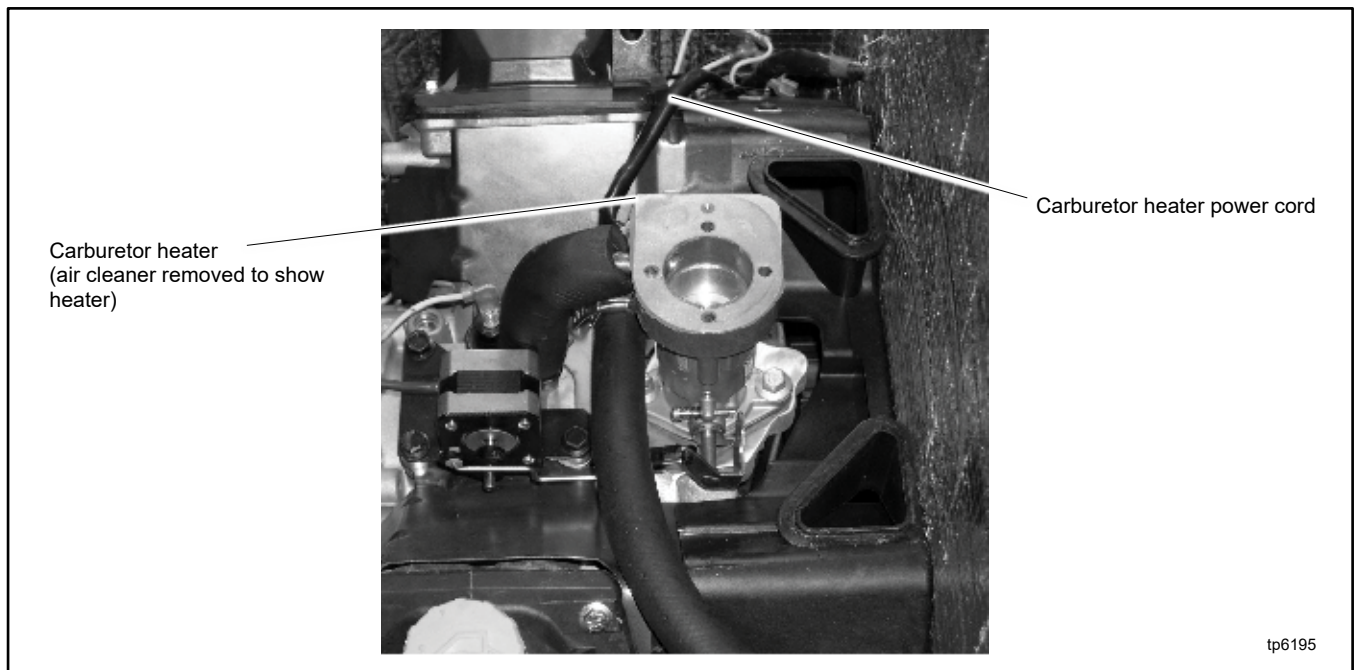

Figure 27 Carburetor Heater Location

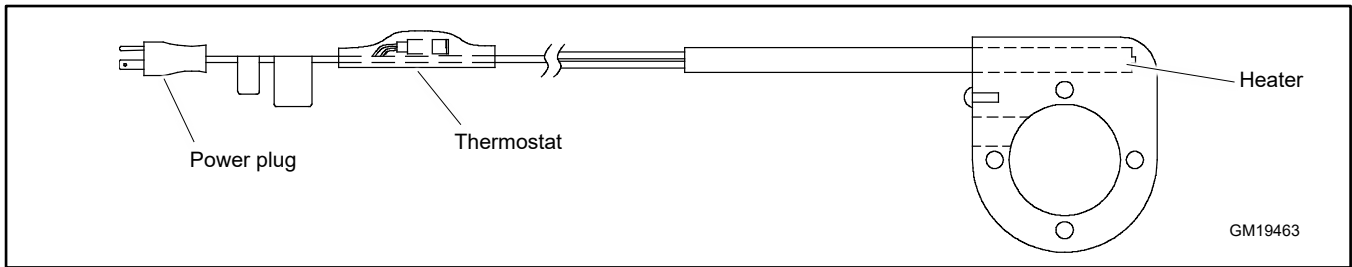

Figure 28 Carburetor Heaters

## 1.11 Prestart Installation Check

Review the entire installation section. Inspect all wiring and connections to verify that the generator set is ready for operation. Check all items in the following Prestart Checklist.

### Prestart Checklist

**Air Cleaner.** Check that a clean air cleaner element is installed to prevent unfiltered air from entering the engine. See the generator set operation manual for instructions.

**Air Inlets.** Check for clean and unobstructed air inlets.

**Battery.** Check for tight battery connections. Consult the battery manufacturer's instructions regarding battery care and maintenance.

**Exhaust System.** Check for exhaust leaks and blockages. Check the muffler condition.

- Inspect the exhaust system components for cracks, leaks, and corrosion. Check for tight exhaust system connections.
- Check for corroded or broken metal parts and replace them as needed.
- Check that the exhaust outlet is unobstructed.

**Oil Level.** Maintain the oil level at or near, not over, the full mark on the dipstick.

**Operating Area.** Check for obstructions that could block the flow of cooling air. Keep the air intake area clean. Do not leave rags, tools, or debris on or near the generator set.

## 1.12 Controller Configuration

### 1.12.1 System Parameters

The controller configuration for each generator model is set at the factory and should not normally require changes. The controller's configuration mode allows adjustment of the system parameters listed in this section. Use the instructions in this section to check the configuration after installation and change them to match the settings shown in Figure 1, if necessary.

Parameter	Setting	Definition
Unit's system voltage and frequency	Uu01	120/240 VAC, 60 Hz (single phase)
	Uu06	115/230 VAC, 50 Hz (single phase)
Controller type	Uc01	ADC-RES (distributor) (Use for 12RES)
	Uc05†	DC-RET (retail)‡
Engine type	Ec00	12RES
Communication setting*	Cn00	No J1939 communication. Sleep mode enabled (48-hour power down in AUTO).
	Cn01†	J1939 communication enabled. Sleep mode disabled (no power down in AUTO).
* Controller application code version 1.13 or higher.		
† Default setting for application code version 1.13 or higher.		
‡ Default setting for service replacement controllers. Change to Uc01 for the 12RES.		

Figure 29 Controller Configuration Parameters

Follow the instructions in the Application Code Version section to enter the configuration mode while the engine is not running and then step through the following parameters. Use the up (Λ) and down (v) arrow buttons to select the appropriate setting for the application.

The controller will automatically exit the configuration mode without saving any changes after about 1 minute if no buttons are pressed. Start the configuration procedure over again from the beginning if the controller exits the configuration mode before the settings have been saved.

#### Note:

Be sure to save your settings before exiting the configuration mode. The controller reverts to the last saved settings when the master switch is moved to the OFF/RESET position.

**Voltage/frequency setting (Uu).** Select the system voltage and frequency from the table in Figure 1.

#### Note:

The Uu parameter sets the system's rated voltage and frequency. To adjust the output (measured) voltage and frequency, see the Voltage and Frequency Adjustments section.

**Engine configuration (Ec).** The engine configuration must match the generator set engine type.

**Controller type (Uc).** The Uc setting is used during initial controller installation in the factory or controller replacement in the field. The Uc setting can be changed only once. The default setting for service replacement controllers is Uc05, controller type DC-RET. Changing it to UC01 sets the controller type to ADC-RES. Uc01 is the correct setting for the Model 12RES.

**Communication/Sleep Mode Setting (Cn).** (Available on controllers with application code version 1.13 or higher.) The communication setting enables or disables J1939 communication, and also disables or enables the sleep mode. When J1939 communication is enabled, the sleep mode is turned off to allow uninterrupted communication with a personal computer running remote monitoring software. If remote monitoring is not used, the communication can be turned off, enabling the sleep mode which causes the controller to power down after 48 hours of inactivity. The generator set master switch must be in AUTO for the sleep mode to function.

The default setting for controllers with application code version 1.13 or higher is Cn01, communication on/sleep mode off. Controllers with earlier application code versions have communication disabled and the sleep mode enabled. The Cn setting is not adjustable on these earlier versions.

### 1.12.2 Application Code Version

To check the application code version number, HOLD the select button while moving the generator set master switch to RUN. (The engine will not start when the select button is held.) Wait about 5 seconds for the application code version number to appear on the display. See Figure 1.























Controller Configuration Mode:		Display:
<b>Hold the Select button:</b>		
	<b>Move the generator set master switch to the RUN position. (The generator set engine will not start).</b>	<input type="text" value="."/> <input type="text" value="0"/>
	<b>Wait about 5 seconds until the display shows the program version number. (The number may be different than the one shown here).</b>	<input type="text" value="v"/> <input type="text" value="1"/> <input type="text" value="1"/> <input type="text" value="3"/>
	<b>Press the down arrow key and then the up arrow key 3 times to enter the configuration mode. (This is the controller "password").</b>	<input type="text" value="U"/> <input type="text" value="u"/> <input type="text" value="0"/> <input type="text" value="1"/>
	     	
<b>Now release the Select button.</b>		
<b>Press:</b>		
 or 	To change the voltage/frequency setting, if necessary. See the Controller Configuration Parameters figure.	<input type="text" value="U"/> <input type="text" value="u"/> <input type="text" value="0"/> <input type="text" value="x"/>
	To enter setting and step to the next parameter, controller type Uc.	
 or 	To change the controller type, only if necessary. This setting is used during controller replacement and can be changed only once.	<input type="text" value="U"/> <input type="text" value="c"/> <input type="text" value="0"/> <input type="text" value="1"/>
	To enter setting and step to the next parameter, engine type Ec.	
 or 	To change the engine type, if necessary.	<input type="text" value="E"/> <input type="text" value="c"/> <input type="text" value="0"/> <input type="text" value="0"/>
	To enter setting and step to the next parameter, communication setting Cn.	
 or 	To change the communication setting, if necessary. See the Controller Configuration Parameters figure.	<input type="text" value="C"/> <input type="text" value="n"/> <input type="text" value="0"/> <input type="text" value="x"/>
	To enter setting and step to SAVE.	<input type="text" value="S"/> <input type="text" value="A"/> <input type="text" value="V"/> <input type="text" value="E"/>
<b>Press:</b>		
	To <b>SAVE CHANGES</b> .	<input type="text" value="Y"/> <input type="text" value="E"/> <input type="text" value="S"/> <input type="text" value=""/>
<b>OR</b>		
	To <b>DISCARD CHANGES</b> without saving.	<input type="text" value="n"/> <input type="text" value="o"/> <input type="text" value=""/> <input type="text" value=""/>
	"Yes" or "no" flashes when the up or down arrow is pressed and then the controller exits the configuration mode. The display returns to the runtime hours.	<input type="text" value="X"/> <input type="text" value="X"/> <input type="text" value="X"/> <input type="text" value="X"/>
<b>Now move the master switch to OFF/RESET.</b>		
<b>Note:</b> Shaded boxes show which number in the controller display changes when the up or down arrow key is pressed. X in the runtime hours display above denotes any number from 0 to 9.		

Figure 30 Configuration Mode (system voltage/frequency, engine type, and communication parameters)

## 1.13 Voltage and Frequency Adjustments

<b>⚠ DANGER</b>	<b>Hazardous voltage. Moving parts.</b> <b>Will cause severe injury or death.</b>
	Operate the generator set only when all guards and electrical enclosures are in place.

**Short circuits. Hazardous voltage/current will cause severe injury or death.** Short circuits can cause bodily injury and/or equipment damage. Do not contact electrical connections with tools or jewelry while making adjustments or repairs. Remove all jewelry before servicing the equipment.

The controller's adjustment mode allows adjustment of the output voltage and frequency, if necessary. Have adjustments performed by a authorized distributor/ dealer.

**Note:**

A digital multimeter that measures voltage and frequency is required for these adjustments.

Use a digital multimeter to check the output voltage and frequency. If output voltage or frequency is not within specifications, use the ADC controller to adjust the output voltage and engine speed (frequency) while the generator set is running. See Figure 1. The flowcharts in the Output Voltage and Frequency Adjustments figure through the Save Mode figure outline the adjustment procedures.

**Note:**

Be sure to save your changes as instructed in the Save Mode figure before exiting configuration mode.



Figure 31 Advanced Digital Control

Changes in voltage and speed adjustments are lost if not saved before the generator set shuts down. The generator set continues to run with the new settings until it shuts down but then reverts to the previous settings at the next startup if the changes have not been saved.

### 1.13.1 Voltage Adjustment

**Note:**

Refer to the flowcharts in the Frequency Adjustment section during the following procedure.

**Voltage Adjustment Procedure**

1. With the generator set off, connect a digital multimeter to the output leads or an electrical outlet on the load side of the generator set. Set the meter to measure AC voltage.
2. Start the generator set by moving the generator set master switch to the RUN position.
3. Use the ADC controller to adjust the voltage (parameter 1P) until the output voltage reaches the desired value. Refer to the flowcharts in the Frequency Adjustment section for instructions to adjust the output voltage. See Figure 1 for the approximate change in voltage per step.

Measured Voltage, VAC	ADC Display	Voltage Change per Step, VAC	
		Coarse	Fine
85-132	1P00-99	5	0.5
180-251	1P00-99	7	0.7

Figure 32 Voltage Adjustment (approximate)

4. Adjust the voltage stability (gain, parameter 2P) to minimize light flicker.
5. Readjust the voltage, if necessary.
6. Set the multimeter to measure frequency.
7. Adjust the engine speed to the cut-in frequency shown in Figure 2 by adjusting the engine governor speed (parameter 4P).

Frequency	Cut-In Frequency
60 Hz	57.5 Hz
50 Hz	47.5 Hz

Figure 33 Cut-In Frequencies

8. Adjust the volts/Hz (parameter 3P) until the voltage level measured by the multimeter begins to drop. When the volts/Hz is set correctly, the generator (as load is applied) attempts to maintain normal output until the engine speed drops below the cut-in frequency set in step 7.
9. Reset the engine speed to the operating frequency (50 or 60 Hz) by adjusting the engine governor speed (parameter 4P).
10. Readjust the voltage stability (gain, parameter 2P), if necessary.
11. Readjust the voltage (parameter 1P), if necessary.
12. Save settings. See the Save Mode figure.
13. Stop the generator set.

### 1.13.2 Frequency Adjustment

The engine speed determines the generator output frequency; 60 Hz units operate at 3600 rpm and 50 Hz units run at 3000 rpm. Adjust the engine governor speed and gain to set the output frequency and stability using the following procedure.

**Note:**

Refer to the flowcharts in Figure 1 through Figure 3 during the following procedure.

#### Frequency Adjustment Procedure

**Note:**

Refer to the flowcharts in Figure 1 through Figure 3 during the following procedure.

1. Attach a frequency meter to the AC output leads or an electrical outlet on the load side of the generator set.
2. Start and run the generator set until it reaches normal operating temperature (at least 10 minutes).
3. Adjust the electronic governor speed (parameter 4P) to obtain a frequency reading of 60 Hz (or 50 Hz if appropriate). Each step changes the engine speed about 3.6 rpm, which changes the output frequency about 0.06 Hz.
4. Check stability with the generator set running and with no load applied. If the generator set speed is unstable, hunts, or surges, adjust the governor stability (gain, parameter 5P) until the generator set becomes stable with no hunting or surging. (Increasing the gain slows the governor response.)
5. Check the frequency reading. Repeat steps 3 and 4 if necessary to obtain the rated frequency and stable operation.
6. Save settings. See Figure 3.

**Output Voltage and Frequency Adjustment Mode:**

Move the generator set master switch to the RUN position. The generator set engine starts and the controller display shows the engine runtime hours.





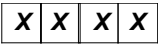

**Hold:**



Wait about 5 seconds until the display changes from runtime hours to the program version number.



Press the down arrow key and then the up arrow key 3 times to enter the adjustment mode. (This is the controller "password.")





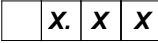
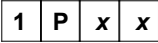





**Display :\***

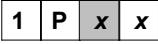



**The controller is now in the voltage coarse adjustment mode.**

**Press:**

 or  To raise or lower the voltage in large increments (approximately 5-7 volts per step). (Parameter 1P)

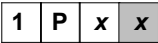

 To enter fine voltage adjustment mode.

 or  To raise or lower the voltage in smaller increments (approximately 0.5-0.7 volts per step). (Parameter 1P)



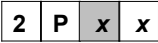

 To enter coarse voltage stability (gain) adjustment mode.



 or  To raise or lower the voltage stability (gain) in large increments. (Parameter 2P)

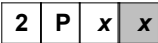

 To enter fine voltage stability (gain) adjustment mode.

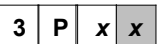

 or  To raise or lower the voltage stability (gain) in smaller increments. (Parameter 2P)

 To enter volts/Hz adjustment mode. (Parameter 3P)



 or  To raise or lower the volts/Hz: 00 = low; 09 = high

**Continued on Figure 2.**

\* Shaded boxes show which character in the controller display changes for each adjustment. X in the examples above denotes any number from 0 to 9. The actual values may vary from model-to-model.



TP6196

Figure 34 Output Voltage and Frequency Adjustments



**Continued from Figure 1:**

**Press:**



 To enter engine governor speed coarse adjustment mode. (Parameter 4P) Display :\*  
4 P x x

 or  To raise or lower the engine speed in large increments.



 To enter engine governor speed fine adjustment mode. (Parameter 4P) Display :\*  
4 P x x

 or  To raise or lower the engine speed in smaller increments.

 To enter engine governor stability (gain) coarse adjustment mode. (Parameter 5P) Display :\*  
5 P x x

 or  To raise or lower the engine governor stability (gain) in large increments.

 To enter engine governor stability (gain) fine adjustment mode. (Parameter 5P) Display :\*  
5 P x x

 or  To raise or lower the engine governor stability (gain) in smaller increments.

 To enter SAVE mode. Go to Figure 3. Display :\*  
S A V E

**Note:**  
**Be sure to save your settings before exiting the configuration mode. The controller reverts to the last saved settings when the master switch is moved to the OFF/RESET position.**

\* Shaded boxes show which character in the controller display changes for each adjustment. X in the examples above denotes any number from 0 to 9. The actual values may vary from model-to-model.

Figure 35 Output Voltage and Frequency Adjustments, Continued

**There are 3 options when the display says SAVE:** S A V E

**Press:**

 To return to the first parameter, coarse voltage adjustment, to check or change settings before saving. See Figure 1. 1 P x x

or

 To save changes. Y E S

or

 To discard changes without saving. n o

**“Yes” or “no” flashes when the up or down arrow is pressed and then the controller exits the configuration mode. The display returns to the runtime hours.** X X X X

**Now move the master switch to OFF/RESET.**

Figure 36 Save Mode

## Section 2. Dimension Drawings and Wiring Diagrams

---

Refer to the dimension drawings and wiring diagrams for your model during generator set installation. Figure 1 lists the drawing numbers and locations.

<b>Drawing Description</b>	<b>Drawing Number</b>	<b>Page</b>
<b>Dimension Drawing</b>	ADV-9747	
Mounting and Dimensions	Sheet 1	40
Clearance	Sheet 2	41
High Wind Mounting	Sheet 3	42
<b>Schematic Diagram</b>	ADV-9232	43
<b>Point-to-Point Wiring Diagram</b>	GM115456	44

Figure 37 Drawing Numbers and Locations

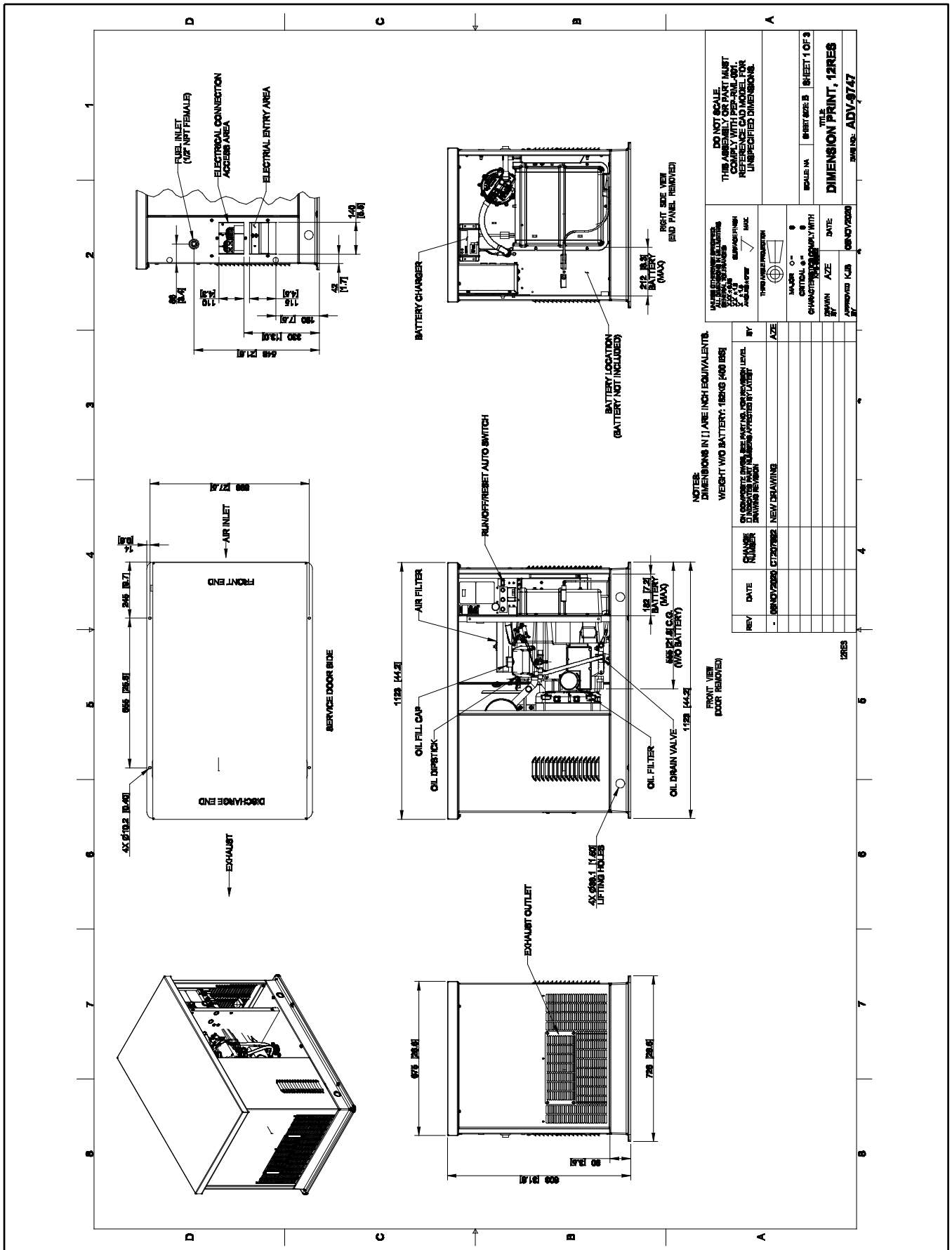
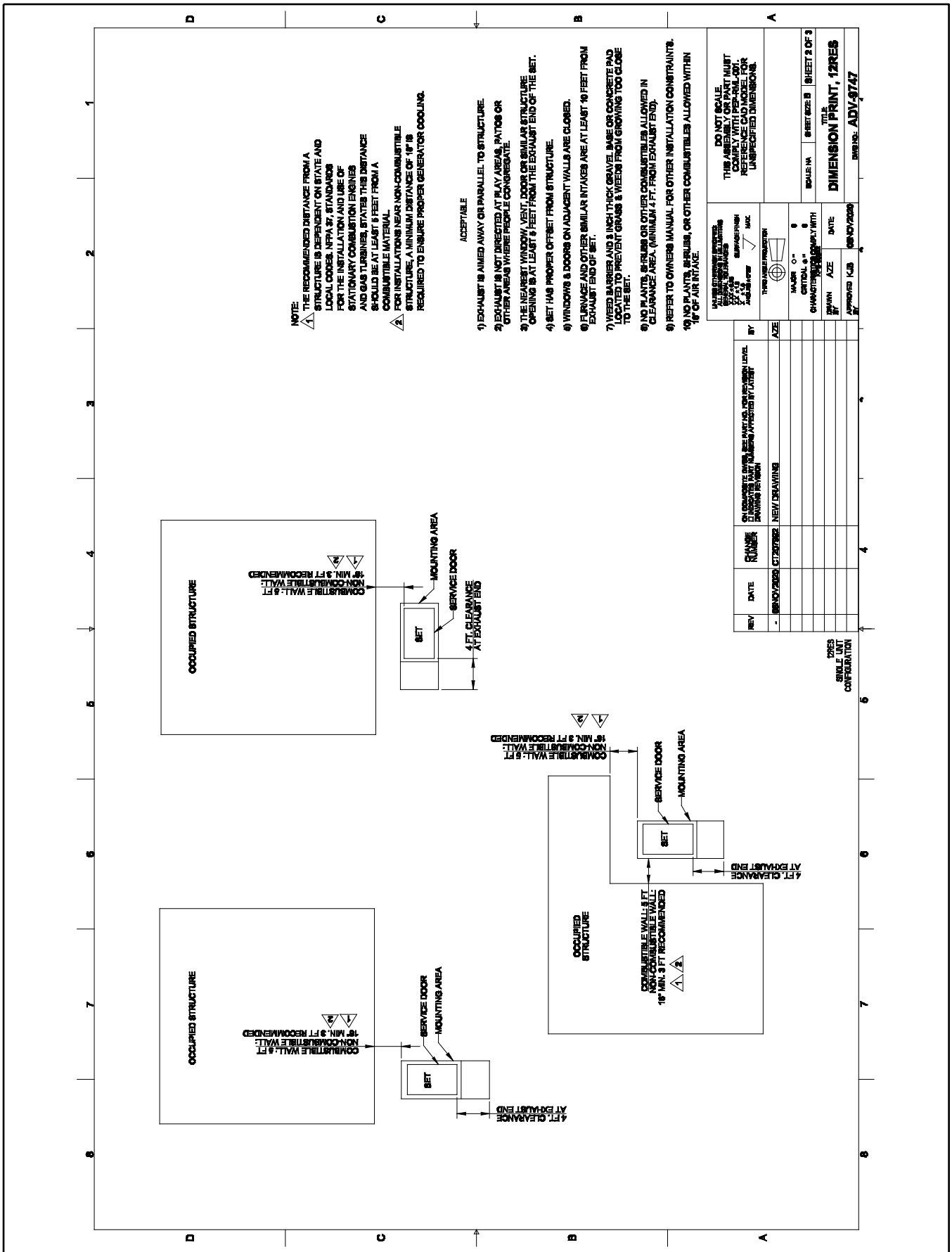

Figure 38 Dimension Drawing ADV-9747, Sheet 1



**NOTE:**  
 1. THE RECOMMENDED DISTANCE FROM A STRUCTURE IS DEPENDENT ON STATE AND LOCAL CODES. REFER BY STANDARDS FOR THE INSTALLATION AND USE OF STATIONARY COMBUSTION ENGINES AND GAS TERMINAL. EXHAUST TERMINAL SHOULD BE AT LEAST 18 FEET FROM A COMBUSTIBLE MATERIAL.  
 2. FOR INSTALLATION NEAR NON-COMBUSTIBLE STRUCTURE, A MINIMUM DISTANCE OF 18\"/>

**ACCEPTABLE**

- 1) EXHAUST IS AIMED AWAY OR PARALLEL TO STRUCTURE.
- 2) EXHAUST IS NOT DIRECTED AT PLAY AREAS, PATIOS OR OTHER AREAS WHERE PEOPLE CONGREGATE.
- 3) THE NEAREST WINDOW, VENT, DOOR OR SIMILAR STRUCTURE OPENING IS AT LEAST 8 FEET FROM THE EXHAUST END OF THE SET.
- 4) SET HAS PROPER OFFSET FROM STRUCTURE.
- 5) WINDOWS & DOORS ON ADJACENT WALLS ARE CLOSED.
- 6) FLURVAGE AND OTHER SIMILAR INTAKES ARE AT LEAST 10 FEET FROM EXHAUST END OF SET.
- 7) WEED BARRIERS AND 3 INCH THICK GRAVEL BASE OR CONCRETE PAD LOCATED TO PREVENT GRASS & WEEDS FROM GROWING TOO CLOSE TO THE SET.
- 8) NO PLANTS, SHRUBS OR OTHER COMBUSTIBLES ALLOWED IN CLEARANCE AREA. (MINIMUM 4 FT. FROM EXHAUST END).
- 9) REFER TO OWNERS MANUAL FOR OTHER INSTALLATION CONSTRAINTS.
- 10) NO PLANTS, SHRUBS, OR OTHER COMBUSTIBLES ALLOWED WITHIN 18\"/>

**DO NOT SCALE.**  
 THIS ASSEMBLY OR PART MUST BE IDENTIFIED BY THE MANUFACTURER'S REFERENCE CAD MODEL FOR UNSPECIFIED DIMENSIONS.

SCALE: 1/4" = 1'-0"

**DATE:** 11/10/2016  
**BY:** [Signature]  
**APPROVED:** [Signature]

**REVISIONS:**

REV	DATE	DESCRIPTION
1	11/10/2016	NEW DRAWING

**PROJECT:** [Blank]  
**CLIENT:** [Blank]  
**PROJECT NO.:** [Blank]  
**DATE:** [Blank]  
**BY:** [Blank]  
**APPROVED:** [Blank]

DOES  
 SINGLE UNIT  
 CONFIGURATION

Figure 39 Dimension Drawing ADV-9747, Sheet 2



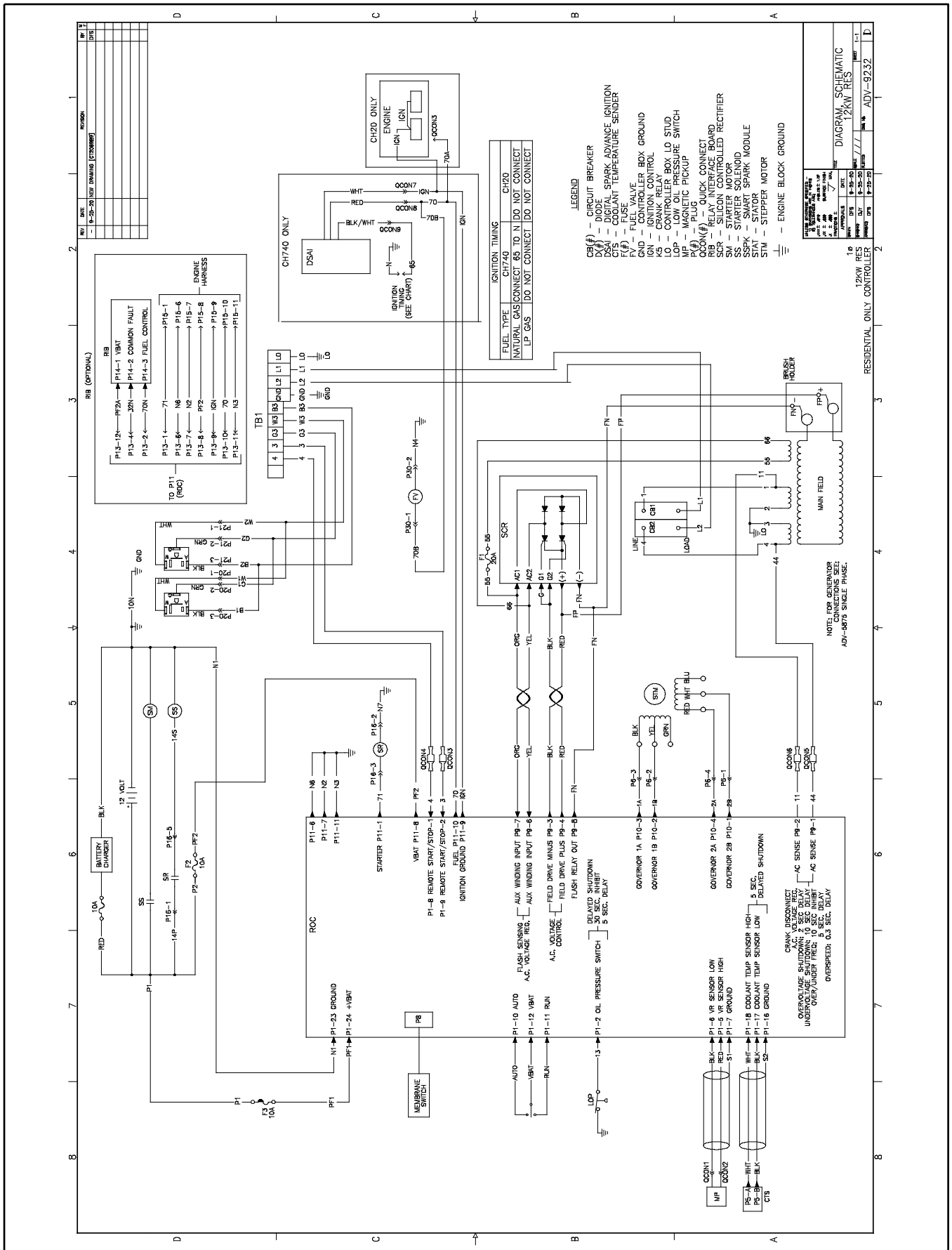

Figure 41 Schematic Diagram, ADV-9232

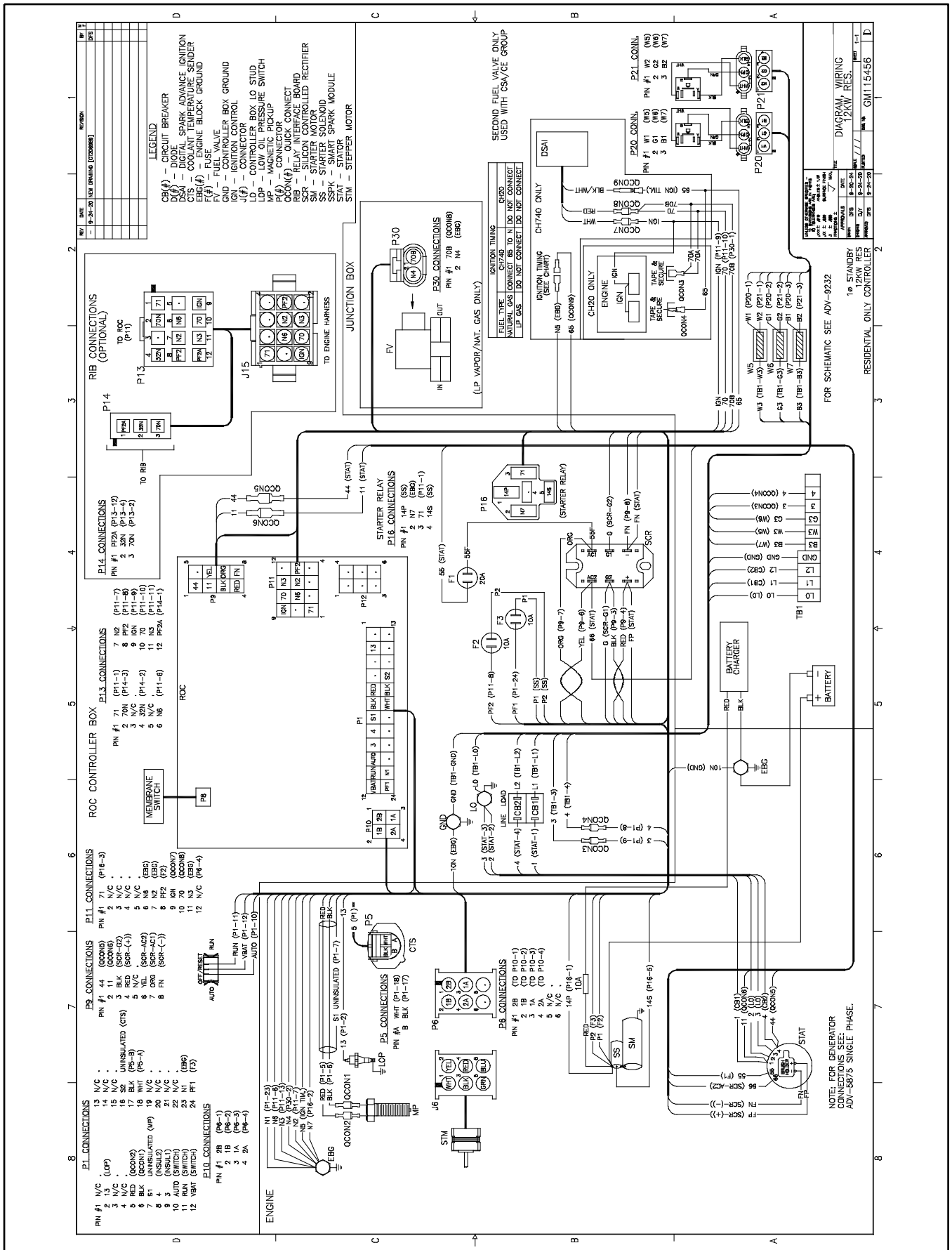

Figure 42 Wiring Diagram, GM115456

## Appendix A. Abbreviations

A, amp	ampere	blk. htr.	block heater	DAC	digital to analog converter
ABDC	after bottom dead center	BMEP	brake mean effective pressure	dB	decibel
AC	alternating current	bps	bits per second	dB(A)	decibel (A weighted)
A/D	analog to digital	br.	Brass	DC	direct current
ADC	advanced digital control; analog to digital converter	BTDC	before top dead center	DCR	direct current resistance
adj.	adjust, adjustment	Btu	British thermal unit	DEF	diesel exhaust fluid
ADV	advertising dimensional drawing	Btu/min.	British thermal units per minute	deg., °	degree
AGM	absorbent glass mat	C	Celsius, centigrade	dept.	department
Ah	amp-hour	cal.	Calorie	dia.	Diameter
AHWT	anticipatory high water temperature	CAN	controller area network	DI/EO	dual inlet/end outlet
AISI	American Iron and Steel Institute	CARB	California Air Resources Board	DIN	Deutsches Institut für Normung e. V. (also Deutsche Industrie Normenausschuss)
ALOP	anticipatory low oil pressure	CAT5	Category 5 (network cable)	DIP	dual inline package
alt.	alternator	CB	circuit breaker	DPDT	double-pole, double-throw
Al	aluminum	CC	crank cycle	DPST	double-pole, single-throw
ANSI	American National Standards Institute (formerly American Standards Association, ASA)	cc	cubic centimeter	DS	disconnect switch
AO	anticipatory only	CCA	cold cranking amps	DVR	digital voltage regulator
APDC	Air Pollution Control District	ccw.	Counterclockwise	E2PROM, EEPROM	electrically-erasable programmable read-only memory
API	American Petroleum Institute	CEC	Canadian Electrical Code	E, emer.	emergency (power source)
approx.	approximate, approximately	cert.	certificate, certification, certified	EATS	Exhaust Aftertreatment System
APU	Auxiliary Power Unit	cfh	cubic feet per hour	ECM	electronic control module, engine control module
AQMD	Air Quality Management District	cfm	cubic feet per minute	EDI	electronic data interchange
AR	as required, as requested	CG	center of gravity	EFR	emergency frequency relay
AS	as supplied, as stated, as suggested	CID	cubic inch displacement	e.g.	for example (exempli gratia)
ASE	American Society of Engineers	CL	centerline	EG	electronic governor
ASME	American Society of Mechanical Engineers	cm	centimeter	EGSA	Electrical Generating Systems Association
assy.	Assembly	CMOS	complementary metal oxide substrate (semiconductor)	EIA	Electronic Industries Association
ASTM	American Society for Testing Materials	com	communications (port)	EI/EO	end inlet/end outlet
ATDC	after top dead center	coml	commercial	EMI	electromagnetic interference
ATS	automatic transfer switch	Coml/Rec	Commercial/Recreational	emiss.	Emission
auto.	Automatic	conn.	Connection	eng.	Engine
aux.	auxiliary	cont.	continued	EPA	Environmental Protection Agency
avg.	average	CPVC	chlorinated polyvinyl chloride	EPS	emergency power system
AVR	automatic voltage regulator	crit.	Critical	ER	emergency relay
AWG	American Wire Gauge	CRM	Common Rail Manifold	ES	engineering special, engineered special
AWM	appliance wiring material	CSA	Canadian Standards Association		
bat.	Battery	CT	current transformer	ESD	electrostatic discharge
BBDC	before bottom dead center	Cu	copper	est.	estimated
BC	battery charger, battery charging	cUL	Canadian Underwriter's Laboratories	E-Stop	emergency stop
BCA	battery charging alternator	cu. in.	cubic inch	etc.	et cetera (and so forth)
BCI	Battery Council International	cw.	Clockwise	exh.	exhaust
BDC	before dead center	CWC	city water-cooled	ext.	external
BHP	brake horsepower	cyl.	Cylinder	F	Fahrenheit, female
blk.	black (paint color), block (engine)	D/A	digital to analog	FDS	Fluid Dosing System

FHM	flat head machine (screw)	in.	inch	Lpm	liters per minute
fl. oz.	fluid ounce	in. H <sub>2</sub> O	inches of water	LOP	low oil pressure
flex.	flexible	in. Hg	inches of mercury	LP	liquefied petroleum
freq.	frequency	in. Lb.	inch pounds	LPG	liquefied petroleum gas
FS	full scale	Inc.	incorporated	LS	left side
ft.	foot, feet	ind.	Industrial	L <sub>wa</sub>	sound power level, A weighted
ft. lb.	foot pounds (torque)	int.	internal	LWL	low water level
ft./min.	feet per minute	int./ext.	internal/external	LWT	low water temperature
ftp	file transfer protocol	I/O	input/output	m	meter, milli (1/1000)
g	gram	IP	internet protocol	M	mega (10 <sup>6</sup> when used with SI units), male
ga.	gauge (meters, wire size)	ISO	International Organization for Standardization	m <sup>3</sup>	cubic meter
gal.	gallon	J	joule	m <sup>3</sup> /hr.	cubic meters per hour
gen.	generator	JIS	Japanese Industry Standard	m <sup>3</sup> /min.	cubic meters per minute
genset	generator set	k	kilo (1000)	mA	milliampere
GFI	ground fault interrupter	K	kelvin	man.	manual
GND, ⊕	ground	kA	kiloampere	max.	maximum
gov.	governor	KB	kilobyte (2 <sup>10</sup> bytes)	MB	megabyte (2 <sup>20</sup> bytes)
gph	gallons per hour	KBus	Kohler communication protocol	MCCB	molded-case circuit breaker
gpm	gallons per minute	kg	kilogram	MCM	one thousand circular mils
gr.	grade, gross	kg/cm <sup>2</sup>	kilograms per square centimeter	meggar	megohmmeter
GRD	equipment ground	kgm	kilogram-meter	MHz	megahertz
gr. wt.	gross weight	kg/m <sup>3</sup>	kilograms per cubic meter	mi.	mile
H x W x D	height by width by depth	kHz	kilohertz	mil	one one-thousandth of an inch
HC	hex cap	kJ	kilojoule	min.	minimum, minute
HCHT	high cylinder head temperature	km	kilometer	misc.	miscellaneous
HD	heavy duty	kOhm, kΩ	kilo-ohm	MJ	megajoule
HET	high exhaust temp., high engine temp.	kPa	kilopascal	mJ	millijoule
hex	hexagon	kph	kilometers per hour	mm	millimeter
Hg	mercury (element)	kV	kilovolt	mOhm, mΩ	milliohm
HH	hex head	kVA	kilovolt ampere	MOhm, MΩ	megohm
HHC	hex head cap	kVAR	kilovolt ampere reactive	MOV	metal oxide varistor
HP	horsepower	kW	kilowatt	MPa	megapascal
hr.	hour	kWh	kilowatt-hour	mpg	miles per gallon
HS	heat shrink	kWm	kilowatt mechanical	mph	miles per hour
hsg.	Housing	kWth	kilowatt-thermal	MS	military standard
HVAC	heating, ventilation, and air conditioning	L	liter	ms	millisecond
HWT	high water temperature	LAN	local area network	m/sec.	meters per second
Hz	hertz (cycles per second)	L x W x H	length by width by height	mtg.	mounting
IBC	International Building Code	lb.	pound, pounds	MTU	Motoren-und Turbinen-Union
IC	integrated circuit	lbm/ft <sup>3</sup>	pounds mass per cubic feet	MW	megawatt
ID	inside diameter, identification	LCB	line circuit breaker	mW	milliwatt
IEC	International Electrotechnical Commission	LCD	liquid crystal display	μF	microfarad
IEEE	Institute of Electrical and Electronics Engineers	LED	light emitting diode	μF	microfarad
IMS	improved motor starting	Lph	liters per hour		

N, norm.	normal (power source)	PMG	permanent magnet generator	SCR	silicon controlled rectifier (electrical), selective catalytic reduction (exhaust emissions)
NA	not available, not applicable	pot	potentiometer, potential	s, sec.	second
nat. gas	natural gas	ppm	parts per million	SI	<i>Systeme international d'unites</i> , International System of Units
NBS	National Bureau of Standards	PROM	programmable read-only memory	SI/EO	side in/end out
NC	normally closed	psi	pounds per square inch	sil.	Silencer
NEC	National Electrical Code	psig	pounds per square inch gauge	SMTP	simple mail transfer protocol
NEMA	National Electrical Manufacturers Association	pt.	pint	SN	serial number
NiCd	nickel cadmium	PTC	positive temperature coefficient	SNMP	simple network management protocol
NFPA	National Fire Protection Association	PTO	power takeoff	SPDT	single-pole, double-throw
Nm	newton meter	PVC	polyvinyl chloride	SPST	single-pole, single-throw
NO	normally open	PVC	polyvinyl chloride	spec	specification
no., nos.	number, numbers	PWM	pulse width modulated, pulse width modulation	specs	specification(s)
NPS	National Pipe, Straight	qt.	quart, quarts	sq.	square
NPSC	National Pipe, Straight-coupling	qty.	quantity	sq. cm	square centimeter
NPT	National Standard taper pipe thread per general use	R	replacement (emergency) power source	sq. in.	square inch
NPTF	National Pipe, Taper-Fine	rad.	radiator, radius	SMS	short message service
NR	not required, normal relay	RAM	random access memory	SS	stainless steel
Ns	nanosecond	RDO	relay driver output	std.	standard
OC	overcrank	ref.	reference	stl.	Steel
OD	outside diameter	rem.	Remote	tach.	Tachometer
OEM	original equipment manufacturer	Res/Com	Residential/Commercial	TB	terminal block
OF	overfrequency	RFI	radio frequency interference	TCP	transmission control protocol
opt.	option, optional	RH	round head	TD	time delay
OS	oversize, overspeed	RHM	round head machine (screw)	TDC	top dead center
OSHA	Occupational Safety and Health Administration	rly.	Relay	TDEC	time delay engine cooldown
OSHPD	Office of Statewide Health Planning and Development (California)	rms	root mean square	TDEN	time delay emergency to normal
OV	overvoltage	rnd.	Round	TDES	time delay engine start
oz.	ounce	RO	read only	TDNE	time delay normal to emergency
p., pp.	page, pages	ROM	read only memory	TDOE	time delay off to emergency
PC	personal computer	rot.	rotate, rotating	TDON	time delay off to normal
PCB	printed circuit board	rpm	revolutions per minute	temp.	temperature
pF	picofarad	RS	right side	term.	Terminal
PF	power factor	RTDs	resistance temperature detectors	THD	total harmonic distortion
ph., ø	phase	RTU	remote terminal unit	TIF	telephone influence factor
PHC	Phillips® head Crimptiter (screw)	RTV	room temperature vulcanization	tol.	Tolerance
PHH	Phillips® hex head (screw)	RW	read/write	turbo.	Turbocharger
PHM	pan head machine (screw)	SAE	Society of Automotive Engineers	typ.	typical (same in multiple locations)
PLC	programmable logic control	scfm	standard cubic feet per minute	UF	underfrequency

UHF	ultrahigh frequency
UIF	user interface
UL	Underwriter's Laboratories, Inc.
UNC	unified coarse thread (was NC)
UNF	unified fine thread (was NF)
univ.	universal
URL	uniform resource locator (web address)
US	undersize, underspeed
UV	ultraviolet, undervoltage
V	volt
VAC	volts alternating current
VAR	voltampere reactive
VDC	volts direct current
VFD	vacuum fluorescent display
VGA	video graphics adapter
VHF	very high frequency
W	watt
WCR	withstand and closing rating
w/	with
WO	write only
w/o	without
wt.	weight
xfmr	transformer







**TP-6967 4/26c**

*Original Instructions (English)*

© 2026 Discovery Energy, LLC - All rights reserved.

**KOHLER**<sup>®</sup>  
Generators

Discovery Energy, LLC  
200 Twin Oaks Road, Kohler, WI 53044 USA  
For the nearest sales and service outlet in the  
US and Canada, phone 1-800-544-2444  
[kohlgenerators.com](http://kohlgenerators.com)

