

Operation and maintenance manual

Engine

TAD1640GE-B

TAD1641GE-B

TAD1642GE-B

TAD1650GE

TAD1651GE

TWD1643GE

TWD1644GE

TWD1653GE

TWD1645GE

VOLVO

33521067801_2_1

TP-6662 8/24

47714681-01/08/2024

V O L V O P E N T A

OPERATOR'S MANUAL

16L





WARNING!

Operating, servicing and maintaining a marine vessel can expose you to chemicals including engine exhaust, carbon monoxide, phthalates, and lead which are known to the State of California to cause cancer and birth defects or other reproductive harm.

Breathing diesel engine exhaust exposes you to chemicals known to the State of California to cause cancer and birth defects or other reproductive harm. To minimize exposure, avoid breathing exhaust when operating, servicing and maintaining the engine.

- Always start and operate the engine in a well-ventilated area.
- If in an enclosed area, vent the exhaust to the outside.
- Wear gloves or wash your hands frequently when servicing the vessel.
- Do not modify or tamper with the exhaust system.
- Do not idle the engine except as necessary.

For more information

www.P65warnings.ca.gov/marine

www.p65warnings.ca.gov/products/diesel

Table of Content

Foreword	3
Safety Information	4
Before start of engine	8
Introduction	12
Fuel, oils and coolant	13
Maintenance and replacement parts	13
Excessive strain on a product and components	15
Blue light mode	17
Volvo Penta Dealer Network	18
Volvo Penta Action Service	18
Presentation	19
Engines	19
EMS (Engine Management System)	20
Instruments and Controls	21
Display Control Unit	21
DU (Display Unit)	31
CIU (Control Interface Unit)	34
Easy Link Instruments	35
Starting	36
Before Starting	36
Starting the Engine	37
DCU (Display Control Unit)	37
Starting in Extreme Cold	38
Never Use Start Spray	39
Starting Using Auxiliary Batteries	39
Operation	40
Reading the Instruments	40
Alarms	40
Maneuvering	41
Operation at low load	41
Engine Shutdown	43
Before Engine Shutdown	43
Stop the Engine	43
Auxiliary Stop	44
After Engine Shutdown	45
Fault handling	46
Diagnostic Function	46
DCU (Display Control unit)	46
DCU II (Display Control Unit)	47
DU (Display Unit)	48
CIU (Control Interface Unit)	49
Easy Link Instruments	49
Erasing fault codes	50
Fault Tracing	51
Fault Code Register	53
Maintenance Schedule	58
Maintenance	59
Orientation	59
Engine, General	64
Air Filter, Check and Replace	64

Charge Air Pipe, Leakage Check	65
Drive Belt and Alternator Belt, Inspection	65
Drive Belt, Replace	66
Alternator Belt, Replace	67
Lubrication System	68
Oil level, checking and topping up	69
Engine Oil, Replace	70
Oil Filter/By-pass Filter, Replace	71
Fuel System	72
Draining condensate, fuel system	72
Engine Fuel Filter Replacement	73
Fuel Pre-filter, Replace	74
Fuel system, bleeding	75
Cooling System	76
Coolant Level, Checking and Topping Up	77
Coolant, Draining	79
Charge Air Cooler, External Cleaning	79
Cooling System, Cleaning	80
Cooling air filter	82
Electrical System	83
Main switch	83
Electrical Connections	83
Battery	84
Storage	86
Technical Data	88
Engines	88
Lubrication System	90
Viscosity	90
Fuel System	91
Cooling System	93
Coolant, Mixing	94
Water Quality	94
Electrical System	95
Identification Numbers	96
Index	101

Foreword

Welcome!

Volvo Penta engines are designed to fulfill Volvo's core values; quality, safety and environmental care. After more than 100 years as an engine manufacturer, the Volvo Penta brand has also become a symbol of reliability, technical innovation, top-of-the-range performance and long service life. Volvo Penta engines are used all over the world, in different operating conditions.

Make sure to thoroughly read through the Operator's Manual regarding operating and maintenance. It contains the information you need to be able to operate and maintain the engine safely and correctly. Pay careful attention to the safety instructions included in the manual.

As the owner of a Volvo Penta engine, you become part of a worldwide network of dealers and service workshop that assist you with technical advice, service requirements and replacement parts. Contact your nearest authorized Volvo Penta dealer for assistance.

It is possible to buy additional literature about your Volvo Penta engine. More information on how to do this can be found at www.volvopenta.com.

Information about your closest Volvo Penta dealer and other useful news and information can be found at www.volvopenta.com and by following Volvo Penta on Facebook.

**V O L V O
P E N T A**

www.volvopenta.com



www.facebook.com/volvopenta

Safety Information

This chapter describes how safety precautions are presented in the manual and on the product. Read the chapter through very carefully before you start the engine or do any maintenance or service. It has to do with your safety; an incorrect operation can lead to personal injury and damage to products or property. It also gives you an introduction to the basic safety rules for using and looking after the engine.

If anything remains unclear or if you are unsure of something, contact your Volvo Penta dealer for assistance.

IMPORTANT:

Always follow local safety instructions and regulations.

Safety texts have the following order of priority:

DANGER!

Indicates a hazardous situation, which, if not avoided, result in death or serious injury.

WARNING!

Indicates a hazardous situation, which, if not avoided, could result in death or serious personal injury.

CAUTION!

Indicates a hazardous situation, which, if not avoided, could result in minor or moderate personal injury.

IMPORTANT:

Indicates a situation, which, if not avoided, could result in property damage.

NOTICE! Used to draw attention to important information that facilitates work or operations.



This symbol is may be used on the product to call your attention to the fact that this is safety information. Always read such information very carefully.

Make sure that warning and information symbols on the engine are clearly visible and legible. Replace symbols that have been damaged or have been painted over.



In some cases, this symbol is used on our products and refers to important information in the Operator's Manual.

Most chemicals such as engine and transmission oils, glycol, petrol and diesel oil and chemicals used in workshops such as degreasing agents, paint and solvents are harmful to health.

Carefully read the instructions on the product packaging! Always follow the safety regulations, such as the use of protective masks, goggles, gloves, etc. Make sure that other personnel are not exposed to substances that are hazardous to health. Ensure good ventilation.

Manage used and leftover chemicals in the prescribed manner.

Daily Checks

▲ WARNING!

Do not start the engine if there is reason to suspect fuel leaks or if there is explosive material nearby.

Make it a habit to give the engine and engine compartment a visual check before the engine is started and after operations, once the engine has stopped. This helps you to quickly discover fuel, coolant or oil leakages or any other abnormality that has occurred, or is about to occur.

Personal safety equipment

▲ CAUTION!

Always use appropriate safety equipment. Personal protective equipment does not eliminate the risk of injury but it will reduce the degree of injury if an accident does happen.

Some examples are ear protection, eye and face protection, protective footwear, personal protective equipment, head protection, protective clothing, gloves and respirators.

▲ WARNING!

Ensure that all machine guards and safety devices are in place and are functional.

▲ CAUTION!

Never use tools or products that show signs of damage.

Protect your eyes

▲ CAUTION!

Wear safety glasses.

Always wear safety glasses if there is a risk of splintering, sparks and spray from the electrolyte (so-called battery acid), or other chemicals. Your eyes are very delicate and damage can result in loss of sight!



P0024482

Protect your skin

⚠ CAUTION!

Risk of skin damage.

Avoid getting oil on your skin! Prolonged or repeated exposure to oil can dry out the skin. Thereafter, irritation, dryness and eczema and other skin problems may occur.

Use protective gloves and avoid oil-soaked clothes and rags. Wash regularly, especially before eating. Wear suitable protective creams to prevent skin from drying out and to facilitate cleaning.

Fire safety

⚠ WARNING!

Fire and Explosion Risk!

Accidental spark could ignite fuel vapors.

All fuels – as well as many lubricants and chemicals – are flammable. Do not allow open flames or sparks near them. **Smoking forbidden!** Hydrogen from the batteries is also very flammable and explosive in certain mixture with air.

Ensure that the workplace is well ventilated and take the necessary precautions before welding or grinding begins. Always ensure that there is a fire extinguisher close at hand in the work area.



P0024470

Spare parts — safety

⚠ WARNING!

Always use spare parts with the same quality as genuine Volvo Penta parts to minimize the risk of an explosion or fire.

Components in fuel systems and electrical systems on Volvo Penta engines are designed and manufactured to minimize the risk of explosions and fire, in accordance with applicable legal requirements.

Used oils, filters and chemicals etc.

⚠ WARNING!

Risk of fire.

Store fuel soaked rags and other flammable material so that there is no danger of them catching fire.

Oil-soaked rags can spontaneously ignite under certain circumstances.

IMPORTANT:

Used fuel and oil filters are environmentally hazardous waste and must be taken to an approved waste management facility for correct handling, as must any used lubricating oil, contaminated fuel, paint residue, solvents, degreasers and wash residue.

Prevent start of the engine

⚠ WARNING!

Immobilize the engine by turning off the power supply with the main switch(es) and lock it (them) in the off position before starting work. Place a warning notice at the main switch.

If the engine is equipped with BMS (Battery Management System), always disconnect both battery cables from the battery terminals.

Ventilation when running the engine

⚠ WARNING!

Only start the engine in a well-ventilated area. If operating the engine in a closed area ensure that there is exhaust ventilation leading out of the work area to remove exhaust gases and crankcase ventilation emissions.

The engine must not be operated in areas where there are explosive materials or stored gas.

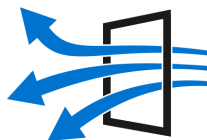

P0024481

Rotating parts and hot surfaces

⚠ DANGER!

Working with or approaching a running engine is a safety risk. Watch out for rotating components and hot surfaces.

If the engine is in operation and operates another device, you must not, under any circumstances, staying close to the engine.



P0024808

Work on running engines is strictly prohibited. There are however adjustments that require the engine to be run. Approaching a running engine is a safety risk. Loose clothing and long hair can get caught in the rotating parts; careless movements or a dropped tool can lead to serious personal injury.

Be careful to avoid hot surfaces (exhaust pipes, turbochargers, charge air manifolds, start elements etc.) and hot fluids in pipes and hoses on engines that are running or have just stopped. Re-install all protective covers that were removed during maintenance work before starting the engine.

Information on the engine

IMPORTANT:

Make sure that all warning and information decals on the product are always visible. Replace decals which have been damaged or painted over.



P0024483



P0024688

Prohibition on use of start spray

⚠ WARNING!

Never use start spray or similar agents to start an engine. This may cause an explosion in the inlet manifold. Risk of personal injury.

Before start of engine

⚠ WARNING!

Never start the engine if there is reason to suspect fuel and/or gas leaks, or if there is explosive material nearby.

IMPORTANT:

Only start the engine with the air filter and protective caps fitted. Foreign objects in the inlet line could cause machine damage. Also make sure that no tools or other parts have been left next to the engine.

⚠ WARNING!

Never start the engine with the valve cover removed. There is a risk of personal injury. For engines with turbochargers, the rotating compressor turbine can in addition cause serious personal injuries.

Before any work on the electrical system

⚠ WARNING!

Always stop the engine first. Then disconnect the current at the main switches and any external power supply before working on the electrical system – to minimize the risk of electrical hazards.

IMPORTANT:

Never disconnect the current using the main switches when the engine is running or by disconnecting the battery cables. The alternator and electronics could be damaged.

Avoid damage to the engine control module and other electronics

IMPORTANT:

Switch off the main switch before connecting or disconnecting a connector.

Before welding work

IMPORTANT:

Before any work with electric weld can begin, the connection to all control units must be disconnected. After finished welding, re-connect the connection to all control units before connecting any battery cable.

Before any work on the cooling system

⚠ WARNING!

Stop the engine and let it cool before starting work on the cooling system. Hot fluids and hot surfaces can cause burns.

Hot coolant under pressure

⚠ CAUTION!

Hot coolant can cause burns. Avoid opening the filler cap for the coolant when the engine is still hot. Steam or hot coolant can spray out and system pressure is lost.

Open the filler cap slowly and release the pressure in the cooling system if the filler cap or valve must be opened – or if a plug or a coolant hose must be removed from a hot engine.

Hot oil under pressure

⚠ CAUTION!

Hot oil can cause burns. Avoid getting hot oil on the skin. Ensure that the lubrication system is not pressurized before starting any work. Never start or operate the engine without the oil filler cap is on. There is a risk that hot oil can spray out.

Refueling

⚠ WARNING!

There is always a risk of fire and explosion during refueling. Smoking is forbidden and the engine must be stopped.

Proper fuel quality

IMPORTANT:

Always use the fuel recommended by Volvo Penta. See *Technical Data* in Operator's Manual. Other fuel can damage the engine.

Wrong fuel quality can also lead to higher service costs.

⚠ WARNING!

Risk of personal injury.

Wrong fuel quality in a diesel engine can cause the fuel control mechanism to bind which can cause the engine to overspeed!

Legal requirements to use proper fuel

IMPORTANT:

To meet regulatory requirements for certified emission levels must always recommended fuel according to *Technical Data* in the Operator's Manual be used.

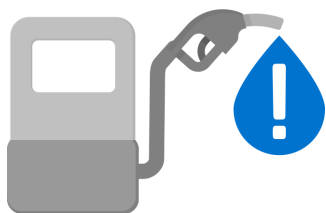

P0024477



P0024488

At any leak detection on the fuel system

⚠ WARNING!

Wear safety goggles!

Be extremely careful when searching for leaks in the fuel system high-pressure circuits. There is very high pressure in the jet from pipes and injectors. The fuel may penetrate the tissue and cause serious risk of blood infection (septicemia).

Handling of fuel pipes

IMPORTANT:

High pressure pipes for fuel must not be bent or straightened under any circumstances. Cracks may occur. Damaged pipes must be replaced.

Safe handling of batteries

⚠ WARNING!

Risk of fire and explosion. Never allow an open flame or electric sparks near the batteries.

A spark caused by an incorrectly connected battery can be enough for the battery to explode with serious injuries.

Do not touch the connections during start attempts. Sparking hazard! Do not lean over batteries.

Correct polarity of the batteries

IMPORTANT:

Make sure that the positive (+) and negative (-) battery cables are correctly connected to the corresponding battery terminals. Wrong connection may cause severe damage to electrical equipment.

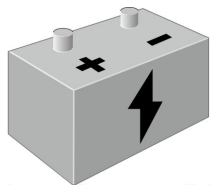

P0024468

Risks of electrolyte in batteries

⚠ WARNING!

Always wear protective goggles when charging or handling batteries.

Battery electrolyte is highly corrosive.

Rinse immediately with copious amounts of water if the electrolyte gets in your eyes. Search directly after the rinsing help by medical staff.

If it comes electrolyte to unprotected skin, wash immediately with soap and water.

Layout of the battery compartment

IMPORTANT:

Make sure the battery compartment is designed according to current safety standards.



P0024486

Cleaning the engine and components

IMPORTANT:

Never use a high pressure washer for cleaning of engine or engine components.

Cleanliness for sensitive components

IMPORTANT:

Observe meticulous cleanliness when handling system components.

Even minimal amounts of dirt could cause a breakdown.

Adjustment of the clutch

CAUTION!

Clutch adjustments must be carried out with the engine stopped.

Introduction

Check that you have received the correct operator's manual before continuing reading. If not, please contact your Volvo Penta dealer.

For engine designations, refer to *Engine*. The designation is stated on the engine plate, refer to , *page 96*.

The illustrations in this book may cover several product types, which means that there may be slight differences between the illustrations and the purchased product. This does, however, not affect the validity of the information and/or instructions in the manual. Volvo Penta reserves the right to make alterations to specifications, design features, and illustrations without prior notice.

To retain the dependability and exhaust emission control originally built into all Volvo Penta engines, it is essential that the engines and receive periodic maintenance according to the maintenance instructions.

At service, software that affects the functionality described in this manual can be updated.

About this manual

This Operator's Manual contains the information required for the correct, safe operation and maintenance of your Volvo Penta engine. Read the Operator's manual carefully and learn to handle the engine and other equipment in a safe manner before you start the engine.

Warranty

Your new Volvo Penta engine is covered by a limited warranty, subject to the conditions compiled in the Warranty Information. AB Volvo Penta's liability is limited to the specification in the Warranty Information and Emission Control System Warranty Statement.

Read the information carefully, as soon as possible after delivery. It includes important information about service and maintenance; the owner is responsible for being familiar with checking and implementing these. Otherwise AB Volvo Penta may deny its warranty obligations in part or in full.

Contact your Volvo Penta dealer if you have not received information on how to access the Warranty Information or recived the Service Book.

Extended Coverage

With the Extended coverage options, customized for each engine's particular needs and working conditions, you can take total control of upcoming operational costs.

For more information regarding our different Services, visit volvopenta.com or contact your Volvo Penta representative.

Running in the engine

The engine must be run in during its first 10 operating hours, as follows:

Run the engine in normal operations. However, full load may not be applied other than for short periods.

Higher oil consumption is normal during the first 100– 200 hours of operation. For this reason, check the oil level more frequently than the normal recommendation.

When a disengageable clutch is installed, it should be checked more carefully during the first days. Adjustments may be necessary to compensate bedding-in of the friction plates.

Fuel, oils and coolant

Only use the fuels and oils recommended in the Operator's Manual (Technical Data), other viscosity and quality may cause malfunctions, increased fuel consumption and possibly shorten the life of the engine.

Always change the oil, oil filters and fuel filters at the specified maintenance intervals.

Make sure to always use suitable and correctly mixed coolant.

If an unsuitable coolant has been used, or if the instructions for coolant mixture have not been followed, future warranty claims related to engine and accessories may be denied.

Maintenance and replacement parts

Volvo Penta engines are designed for maximum reliability and long life and built to withstand a demanding environment. The engines are also designed to have a minimal environmental impact. These qualities will be maintained through regular servicing and the use of spare parts with the same quality as genuine Volvo Penta parts. If reliable and purpose-built parts are not used, your safety, health, and the machine's function may be compromised. Volvo Penta has a world-wide network of authorized dealers.

The authorized dealers are Volvo Penta product specialists, and have the accessories, genuine parts, test equipment and special tools needed for high quality service and repair work. Remember to note the engine / transmission identification number when you **order service and spare parts.**

Excessive strain on a product and components

Volvo Penta products and components are not dimensioned for external loads. Never stand or step onto an engine, transmission or its components. Loads can bring about damage and the malfunction of a product or property.

Environmental care

Environmental care is a core value at Volvo Penta. Energy efficiency and low emissions are among the most important product related aspects and priority focus areas for Volvo Penta business. Several of the global challenges the world faces are directly or indirectly related to power industries and transports. We recognize that Volvo Penta is part of the environmental problems, but we are also convinced that we are a part of the solution.

Volvo Penta currently has a broad engine program in which great advances have been made in reducing exhaust emissions in the same time as the fuel consumption has been improved. Through regular maintenance, the Volvo Penta engines retain its low fuel consumption and low emissions. We hope that you will be keen to preserve these qualities.

Always follow the directions in the Operator's Manual regarding fuel grades, operation and maintenance to avoid unnecessary environmental impact. Contact your Volvo Penta dealer if you notice any changes such as increased fuel consumption or exhaust smoke.

Remember always to hand in environmental hazardous waste such as drained oil, coolant, old batteries, etc. for treatment at a recycling facility. Our united efforts can make a valuable contribution to the environment.

Certified engines

If you own an emission-certified engine used in an area where exhaust emissions are regulated by law, this places special demands on the care and maintenance you provide your engine.

NOTICE! Neglects or failure to follow the points listed here may invalidate the engine emission certificate. This means AB Volvo Penta can no longer guarantee engine conformity with the certified model. Volvo Penta is not responsible for damages or costs arising as a result of this.

- Certification means that an engine type has been checked and approved by the relevant authority. The engine manufacturer guarantees that all engines of the same type are equivalent to the certified engine.
- It is the responsibility of the operator/user to ensure that no intentional misuse of the engine takes place.
- Volvo Penta maintenance and service intervals must be complied with.
- Any case of malfunction must be rectified without delay.
- Only use genuine Volvo Penta parts or spare parts with the same quality as genuine Volvo Penta parts.
- Volvo Penta recommends that service to injection pumps, pump settings and injectors always are carried out by a qualified workshop.
- The engine must not be converted or modified in any way, except with accessories and service kits that Volvo Penta has approved for the engine.
- No installation changes to the exhaust pipe and engine air inlet ducts may be made.
- No warranty seals (where present on the product) may be broken by unauthorized persons.

NOTICE! All kind of tampering or modifications of the engine and it's EATS system will void the type-approval of this particular engine.

Stationary emergency application

If the engine is ordered for stationary emergency applications, it can only be used for emergency operations and required maintenance and testing.

Blue light mode

NOTICE! The functionality for Blue light mode only exists on engines ordered with this function.

The function has been developed for applications intended for use in a qualified emergency situation proclaimed by a national or regional government (authority), its emergency services (or its armed forces). All other use of the function constitutes a violation of the law. Examples of applications can be fire pumps, emergency vehicles or generators.

Activate

The function for Blue light mode is activated automatically and prohibits lowering of performance due to defects in the engine or the aftertreatment system. Triggers for derate due to engine protection are removed. The engine sends warning messages but is not going into derate or shut-down.

Volvo Penta Dealer Network

The Volvo Penta global network of authorized dealers is at your service. We strongly recommend that you take your product to an authorized Volvo Penta dealer for service and repair. They are specialists in Volvo Penta products and have the accessories, genuine Volvo Penta parts, the special tools and the latest service information for high quality service and repair work.

Dealer Locator Services

Locate the nearest Volvo Penta dealer through our dealer locator on www.volvopenta.com or download the dealer locator app to your smartphone.

Volvo Penta Action Service

Our global dealer network, your first line of contact, is backed up by Volvo Penta Action Service, a phone based breakdown and support service providing assistance 24 hours a day, every day of the year.

How it works

A dedicated operator will support you all the way through your case and keep you updated on status and progress.

Whenever on-site assistance or technical support is needed, the operator will put you in contact with the closest Volvo Penta dealer that can support your product.

Phone numbers

Find your Volvo Penta Action Service phone number and more information on www.volvopenta.com.



P0038980

Presentation

TWD1643GE

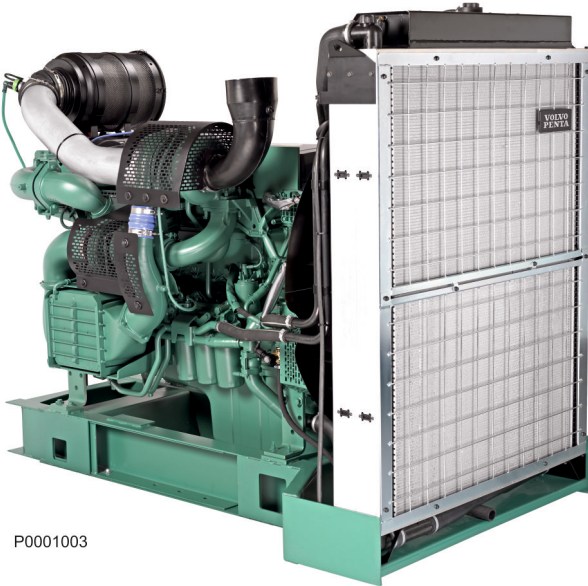

P0001003

Engines

This Operator's Manual contains industrial engines TAD1640VE-C, TAD1641VE-C, TAD1642VE-C, TAD1643VE, TAD1643VE-B, TAD1650VE, TAD1651VE, TAD1650VE-B, TAD1641GE-B, TAD1642GE-B, TAD1650GE, TAD1651GE, TWD1643GE, TWD1644GE, TWD1645GE, TWD1652GE, TWD1653GE

These are in-line, directly injected, 6-cylinder industrial diesel engines. The engines are all equipped with electronically controlled fuel management, turbocharger, charge air cooler, thermostatically controlled cooling systems and electronic speed control.

TAD1650VE, TAD1650VE-B, TAD1651VE, TWD1652GE, TWD1653GE, TAD1650GE and TAD1651GE are equipped with EGR (Exhaust Gas Recirculation).

TAD1643VE-B



P0022328

EMS (Engine Management System)

EMS is an electronic system with CAN communication (Controller Area Network) for diesel engine control. The system has been developed by Volvo Penta and includes fuel regulation and diagnostic functions. The system consists of a control unit, injectors, a number of sensors that supply the control unit with information, and connectors for diagnostics and functional checks. The engine can be connected to a communication interface comprising a CAN link and a serial link.

Input/Output signals

The information from the sensors provides precise data about prevailing operating conditions and allows the processor in the control module to, among other things, calculate correct injection amount, injection timing and check the engine's condition.

Fuel regulation

The engine fuel requirement is analyzed up to 100 times per second. The engine injection volume and injection timing are controlled electronically via the fuel valves in the injectors. The control unit receives signals from sensors and monitors in order to determine when the fuel valve must open and close. This means the engine always receives the correct fuel volume under all operating conditions, which means lower fuel consumption and the lowest possible exhaust emission.

Diagnostic function

The purpose of the diagnostic function is to detect and locate any malfunctions in the EMS system, as well as to protect components from damage.

If a malfunction is detected, this is announced by warning lamps, a flashing diagnostic lamp or a text message on the instrument panel, depending on the equipment fitted. If a fault code is displayed it is used for guidance in any fault tracing. Fault codes can also be read by Volvo's VODIA tool at authorized Volvo Penta workshops.

If there is a serious malfunction, the engine will be shut down completely or the control unit may reduce power output (depending on the application). Fault codes are registered as an aid to fault tracing.

Instruments and Controls

Display Control Unit

The DCU control panel is available as an optional accessory for the EMS (Engine Management System) electronic control system.

The DCU is a digital instrument panel which communicates with the engine control unit. The DCU has several functions, such as engine control, monitoring, diagnostics, and parameter setting.

The menus in the DCU system can be used to check, and in some cases to set, a number of different functions in the EMS system.

NOTICE! Settings and what engine data that appears in the display may vary depending on installation and engine model.

NOTICE! The menus and illustrations shown here are the English version. The language can be changed, however; refer to the *Setup* menu.

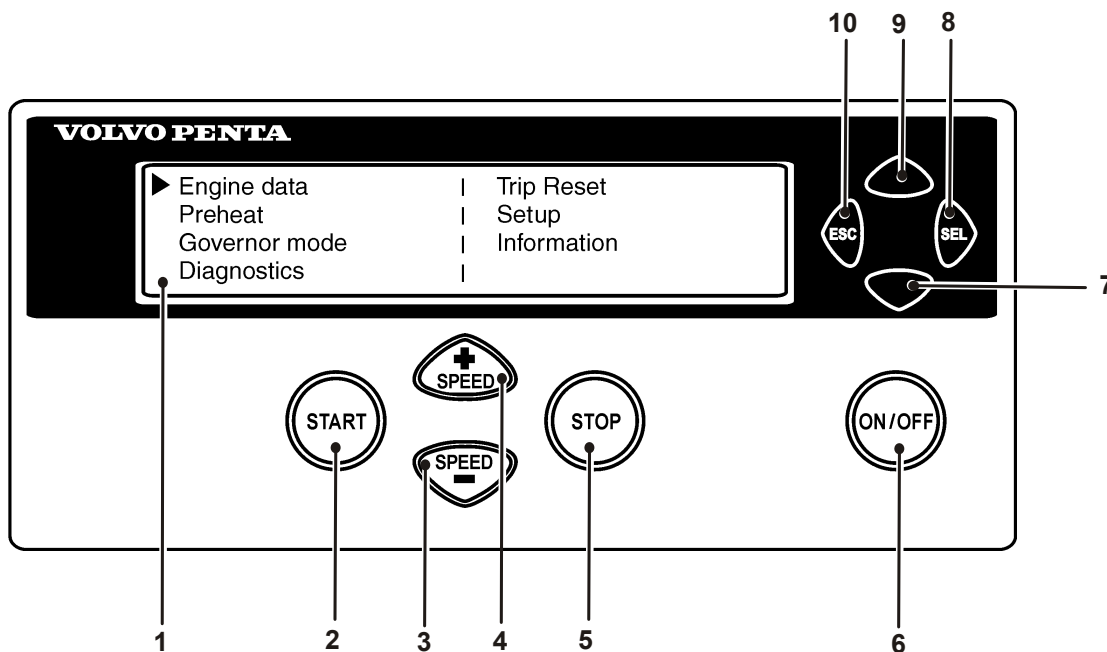

P0002062

Start

When the DCU panel is started, the “Engine Data” menu is displayed; press “ESC” to come to the main menu.

- | | |
|---------------------------------|-------------------------------------------|
| 1 LED display | 6 ON/OFF. Starts and stops the system |
| 2 START. Starts the engine | 7 Scroll downwards in menus |
| 3 SPEED - . Reduces engine rpm | 8 SEL. Selects in menus |
| 4 SPEED +. Increases engine rpm | 9 Scroll upwards in menus |
| 5 STOP. Stops the engine | 10 ESC. Return to previous menu selection |

▶ Engine data		Trip Reset
Preheat		Setup
Governor mode		Information
Diagnostics		

P0002063

▶ Eng speed	rpm		Boost prs	kpa
Cool tamp	c		Boost tmp	C
Oil pres	kpa		Oil temp	C
Eng hours	h		Batt Volt	V

P0002064

Menus

There are several sub-menus under each main menu. There is not space for all the menu choices on the display. To scroll through the menus, use the **7** and **9** buttons on the display. Press the **SEL** button **8** to make a selection. Refer to the illustration on the previous page.

NOTICE! The **Setup** menu can be used to select the language that you want to use on the display.

Main menu

- **Engine data**, current engine data
- **Preheat**, manual activation of pre-heating. Must be activated with temperatures below 0°C (32°F)
- **Governor mode**, activation of droop
- **Diagnostics**, shows fault codes as text
- **Trip reset**, resets trip data
- **Setup**, parameter setting
- **Information**, shows the currently applicable hard/software, data sets and engine identification for the engine and DCU data

Engine data

shows relevant engine data.

- Engine speed, can be controlled with the **SPEED+** and **SPEED-** buttons (rpm)
- Charge pressure (kPa)
- Coolant temperature (°C)
- Charge air temperature (°C)
- Oil pressure (kPa)
- Oil temperature (°C)
- Engine hours (h)
- Battery voltage (V)
- Fuel consumption (l/h)
- Instantaneous fuel consumption (trip fuel) (l)

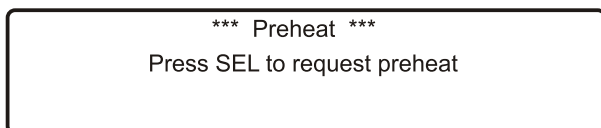

P0002065

Preheat

manual activation of pre-heating. When it is activated, the EMS system senses at start-up if pre-heating is needed. For automatic pre-heating, refer to the *Setup / Preheat on ignition* menu.

NOTICE! Must be activated with temperatures below 0°C (32°F).

The pre-heating time is adjusted to suit the engine temperature, and can last for up to 50 seconds both before and after starting. Refer also to *Starting procedure EMS 2*.

- Press **SEL**, the text **Preheat requested** will be shown
- The display automatically returns to the **Engine Data** menu.

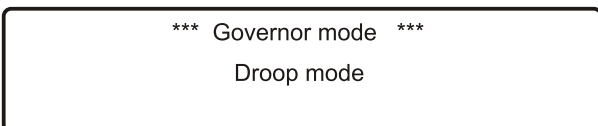

P0002066

Governor mode

activates/shuts off droop. To set the droop level, refer to the *Setup / Governor gradient or Governor droop* menu.

- Select **Isochronous mode** or **Droop mode** with the SEL button.

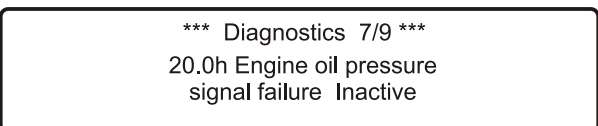

P0002067

Diagnostics

shows the error list containing the 10 latest active and inactive faults. The fault codes are shown as text on the display.

- Scroll through the fault list with the arrow keys.

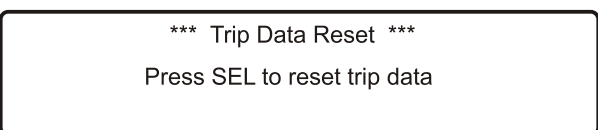

P0002068

Trip Data reset

resets trip data, such as fuel consumption.

- Press the **SEL** button to reset trip data

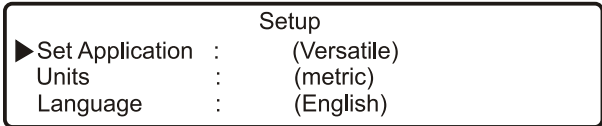

P0002069

Setup

parameter setting in the engine's control systems. Different menus appear under **Customer parameter**, depending on whether **Versatile** or **Gen set** has been selected from **Set application**. See below.

The parameters that can be set/selected (choice is made with the SEL button) are:

- **Set application**, setting **Versatile** or **Gen set**. Depending on the selection made here, different menus will appear under **Customer parameter**.
- **Unit**, setting of units (metric or US imperial).
- **Language**, setting the language used on the display. Choose between English, French, German and Spanish.
- **Stop energized to**, setting of external stop input. Activated by **Stop** or **Run**.
Stop: The stop input must be connected to voltage to stop the engine.
Run: The stop input must be connected to voltage to run the engine.
- **Customer parameter**, setting alarm limits. Refer to *Customer parameter / Versatile* and *Customer parameter / Gen set*.
- **Throttle input setting**, setting of engine-speed control and voltage limits. Refer to *Throttle input setting*.
- *Display setting*, setting the display. refer to *Display setting*.

Customer parameter / Versatile

- **Idle engine speed** - setting idle speed.
- **Preheat on ignition** - activation of automatic preheating. The engine control system senses if preheating is needed and activates it directly at switch-on.
- **Governor gradient (Nm/rpm)** - setting of droop level, when activated. For activation, refer to *Governor droop* in the main menu.
- **Oil temp warning limit (°C)** - setting alarm limit for oil temperature.
- **Coolant temp warning limit (°C)** - setting alarm limit for coolant temperature.

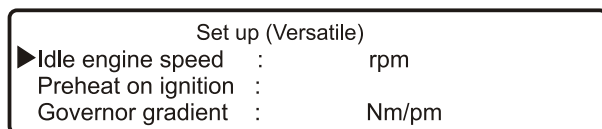

P0002070

Set up (Gen set)	
▶ Primary engine speed	:
Preheat on ignition	:
Governor droop	:

P0002071

Customer parameter / Gen set

- **Primary engine speed** - selection of engine rpm, 1500 or 1800 rpm.
For certain markets due to certification the dual speed (or selection of engine rpm) may not be available.
- **Preheat on ignition** - activation of automatic pre-heating. The engine control system senses if pre-heating is needed and activates it directly at switch-on.
- **Governor droop (%)** - setting of droop level, when activated. For activation, refer to "Governor droop" in the main menu.
- **Overspeed limit (%)** - setting of limit for overspeed alarm, % of set engine rpm.
- **Overspeed shutdown** - activation of engine shut-down with overspeed alarm. Refer to "Overspeed limit" to activate the alarm limit for the excess rpm alarm.
- **Oil temp warning limit (°C)** - setting alarm limit for oil temperature.
- **Coolant temp limit (°C)** - setting alarm limit for coolant temperature.

Setup(Throttle)	
Setup throttle mode	: *** OFF ***

Setup(Throttle)	
▶ Set throttle mode	:
Set idle voltage	:
Set mx voltage	:

P0002955

Throttle input setting

rpm control setting (throttle operation).

- **Set throttle mode** - OFF - engine rpm is controlled via the DCU panel.
ext throttle input - engine speed is controlled with a potentiometer (accelerator).
ext voltage input - engine rpm is controlled by an external unit.
- **Set idle voltage (V)** - idle voltage level setting.
- **Set max voltage (V)** - full throttle voltage level setting.

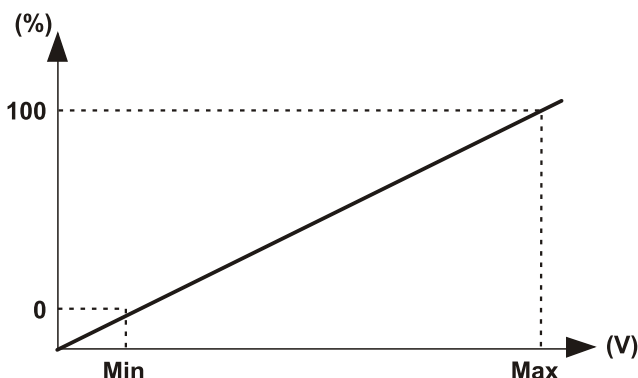

P0002074

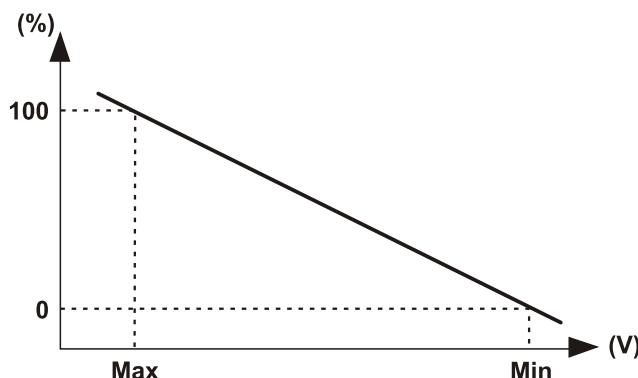



P0002075

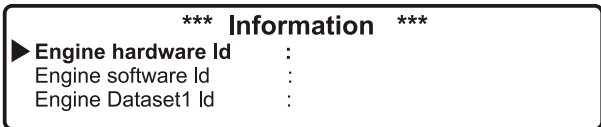

P0002076

Display setting

settings for the display. Adjustment is made with the **7** and **9** buttons; see DCU panel illustration.

- **Set contrast (%)** - contrast setting.
- **Set backlight time (sec)** - time setting (in seconds) for display backlighting on, lighting is then shut off if the panel is not used.
- **Set backlight brightness** - display backlighting brightness setting.

Information

shows the data for the engine and DCU.

- **Engine hardware Id** - engine control unit part number.
- **Engine software Id** - engine control unit software part number.
- **Engine dataset1 Id** - engine data set 1 part number.
- **Engine dataset2 Id** - engine data set 2 part number.
- **Vehicle Id** - chassis number.
- **DCU hardware Id** - DCU part number.
- **DCU software Id** - DCU software part number.
- **DCU dataset1 Id** - DCU data set 1 part number.
- **DCU dataset2 Id** - DCU data set 2 part number.

The Volvo Penta DCU II instrument panel communicates with the engines control unit and has a number of functions as control, monitoring and diagnostics.

NOTICE! Settings and the type of engine data presented on the display may vary depending on the installation and engine model.

Depending on the installation the DCU II can also be used as presentation display only.

NOTICE! The menus and illustrations shown here are the English version. Refer to the section *Settings* to change the display language.



P0018811



Turn On/Off the ignition

START

Start the engine



Reduce engine rpm



Increase engine rpm

STOP

Stop the engine



Scroll upwards in menus



Select and confirm in menus



Scroll downwards in menus



Return to previous menu selection

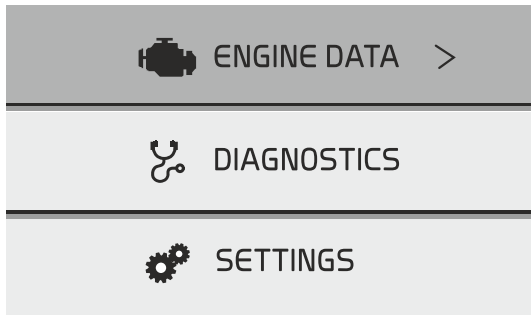



P0018295

Display

The DCU II basic view shows three main menus.



- **ENGINE DATA** (ENGINE DATA), shows current engine data.
- **DIAGNOSTICS** (DIAGNOSTICS), shows active fault codes.
- **SETTINGS** (SETTINGS), shows display and engine settings.

Press  to proceed in the submenus and scroll using the panel arrow buttons.

Press  to return to previous menu.

Status bar

The status bar with symbols for active malfunctions is shown in the top right of the display.

	Emission related malfunction
	EMS system malfunction

Alarms and messages

Messages to the operator are of three types, color coded according to degree of severity.

When a message is shown on the display, press  to reach the diagnostic menu to get more information regarding registered faults and instructions for remedial actions.

- **ALARM** (ALARM), red text, the system has detected a serious fault — Volvo Penta recommends to immediately contact a qualified workshop .
- **WARNING** (WARNING), yellow text, the system has detected a fault — Volvo Penta recommends to contact a qualified workshop as soon as possible.
- **MEDDELANDE** (MESSAGE), blue text, non-critical engine message for the operator.

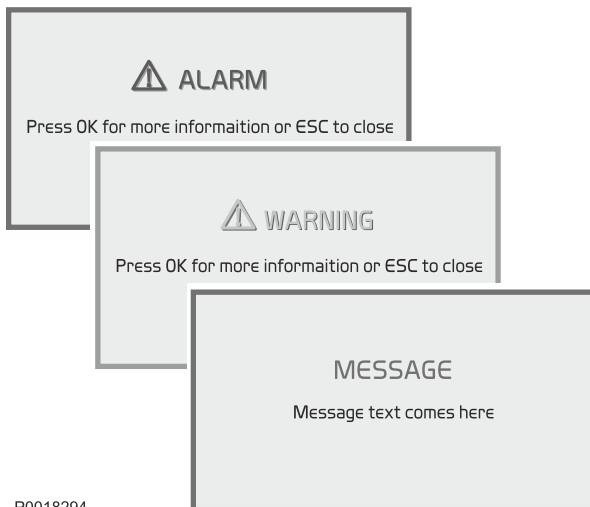

P0018294

ENGINE DATA

Engine Hours	1536h
Fuel Rate	112 l/h
Oil Pressure	425 kPa
Oil Temperature	65 C ✓

Engine Speed **1500** rpm

P0018291

DIAGNOSTICS

- Coolant level low >
- Oil temp sensor failure
- DTC 3
- DTC 4
- DTC 5

Coolant level low 50000h

Check coolant system for leakage.
Fill coolant needed.

critical-Service immediately SPN III FMI I

P0018293

Menus

ENGINE DATA (ENGINE DATA)

Engine data shown may vary depending on the engine installation.

- **Engine Hours** (Engine Hour) (tim)
- **Engine Speed** (Engine Speed) (rpm)
- **Coolant Temperature** (Coolant Temperature) (°C)
- **Oil Pressure** (Oil Pressure) (kPa)
- **Fuel Rate** (Fuel Rate) (l/h)
Current fuel consumption.
- **Boost Temperature** (Boost Temperature) (°C)
- **Boost Pressure** (Boost Pressure) (kPa)
- **Oil Temperature** (Oil Temperature) (°C)

DIAGNOSTICS (DIAGNOSTICS)

If the system detects a malfunction, the operator is informed via a pop-up message on the display. The fault codes are listed in the diagnostics menu; active fault codes are at the top of the list and are denoted by a green dot. For more information regarding cause and remedies, use the arrow button to scroll to the fault concerned and press **OK**. This will also provide information about number of engine hours when the fault became active and the SPN and FMI codes.



P0018292

SETTINGS (SETTINGS)

Display (Display)

- **Set backlight time** (Set backlight time). On/OFF, sets backlight to run in standby mode. *On* is the default setting.
- **Set backlight brightness** (Set backlight brightness). Adjust display backlight brightness using the panel arrow buttons.
- **Set Instrument Brightness** (Set Instrument Brightness). Sets backlighting in the display instrument.
- **Change background color** (Change background color). Select background color, gray or white.

Language (Language)

Sets the display language; chooses between English, French, German, Spanish and Chinese.

Save/Restore (Save/Restore)

- **Save current configuration** (Save current configuration). Save the current display settings.
- **Restore last configuration** (Restore last configuration). Restore the last displayed settings saved.
- **Restore default configuration** (Restore default configuration). Restores *all* display setting menus to factory settings.

NOTICE! The settings in the following menus do not normally need to be changed; should a change be necessary it must be carried out by an authorized Volvo Penta technician. Refer to the installation manual for further engine information.

Authorized Volvo Penta dealer or OEM only

- I/O Status (I/O Status)
- CAN Termination (CAN Termination)
- Stop Logic DCU (Stop Logic DCU)
- Potentiometer supply (Potentiometer supply)
- Speed Control (Speed Control)
- Control display unit (Control display unit)
- Genset/VE (Genset/VE)
- Buzzer (Buzzer)
- Information (Information)

DU (Display Unit)

The DU is a computerized instrument panel which shows engine working values on an LCD screen. In the display it is possible to show multiple windows with different information, i. g. engine rpm, coolant temperature, fuel consumption and fault messages.

At start up, the display performs a self-test. If a constant signal is heard, the system has discovered a malfunction. The display will work but may act in an unexpected way.

The DU is connected between the engine control unit and the CIU or DCU.

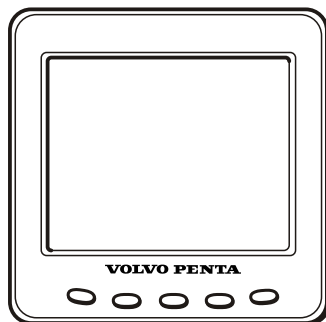

P0002061

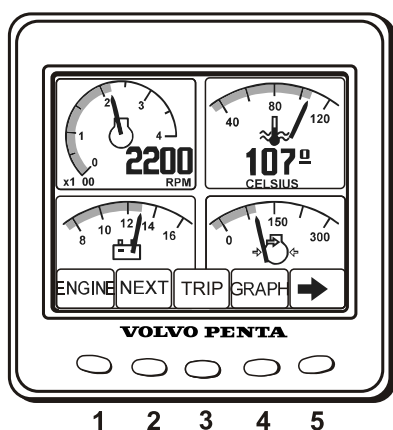

P0002382

Display modes

Press any of button 1–4 to view the function menu for the buttons, appearing in the lower part of the display. To leave the menu, wait a few seconds or press button 5 (EXIT).

- 1 Engine
- 2 Multi
- 3 Trip
- 4 Graph
- 5 Exit

Contrast

In the display modes Engine, Trip and Graph, it is possible to adjust the contrast.

Press button 5 outside the menu and then + (button 4) or – (button 3) to adjust the contrast.

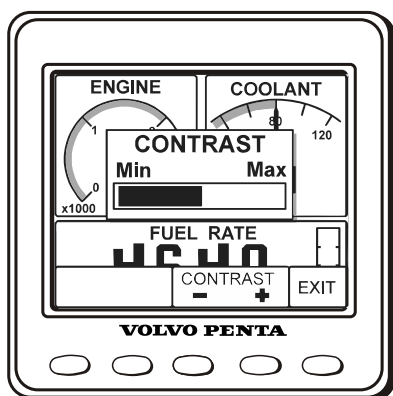

P0002403

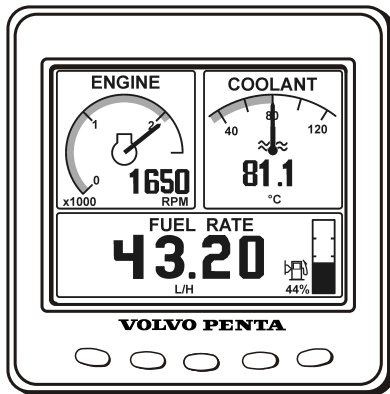

P0002413

Engine

Rpm and coolant temperature is shown in the upper part of the display. In the lower part it will show trip computer and a fuel level indicator, if these function are installed.

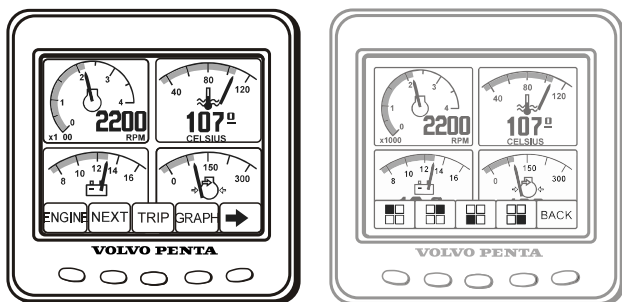

P0014208

Multi

In the multi mode, button 2, the information can be shown in four windows, analogue or digital. The display toggles between the two when button 2 is pressed repeatedly.

By pressing button 5, the right arrow, you choose what information to be shown in the different windows.

Press repeatedly on the button that correspond to the window, until desired information is shown.

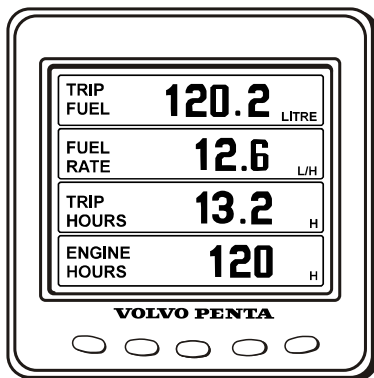

P0002418

Trip

To display the trip computer press button 3, Trip

Trip Fuel, since last reset

Fuel Rate, fuel consumption

Trip hours, since last reset

Engine hours, total amount of operating hours

Reset by pressing button 3 for three seconds until a beep is heard.

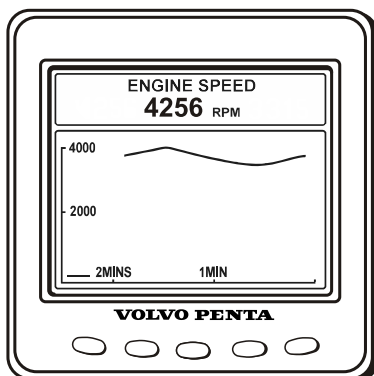

P0014207

Graph

The information is shown as graphs. Press button 4 repeatedly to choose what information will be shown. The time interval is set in the Configuration menu.

If the connection is broken there will be a straight line in the display.

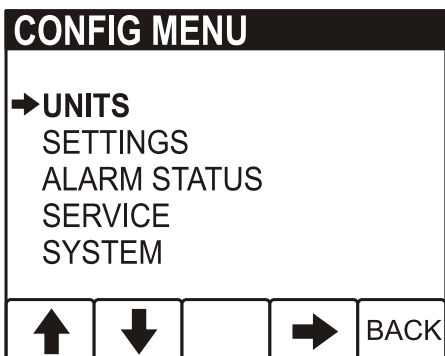

P0014209

Configuration menu

Press button 5 for three seconds to enter the Configuration menu. Navigate with the up and down arrows, select with the right arrow.

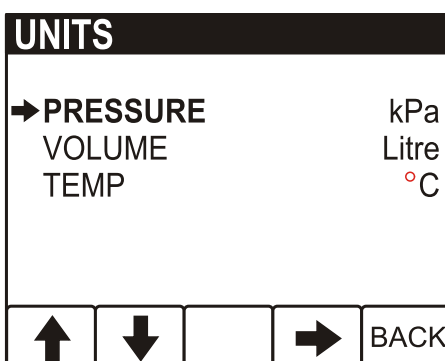

P0014210

Units

- PRESSURE; kPa, PSI
- VOLUME; LITRE, GAL, Imperial GAL.
Fuel rate is adjusted according to volume unit, L/H, GAL/H, IGAL/H.
- TEMPERATURE; °C, °F

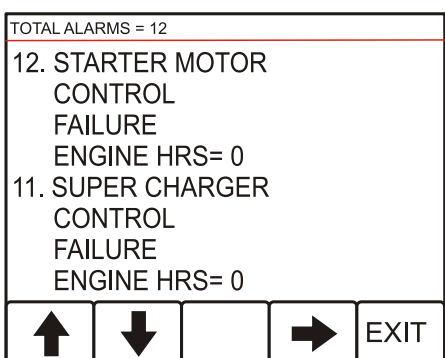

P0014212

Alarm Status

List of active alarms, refer to *Reading fault codes via the DU (Display Unit)*

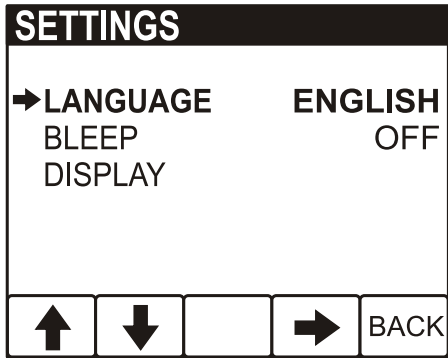

P0014211

Settings

- LANGUAGE; setting of what language is to be used in the display.
- BLEEP; On/Off, setting if pressing the instrument buttons will be followed by a beep or not.
- DISPLAY; setting of ENGINE RPM gauges
RPM ENGINE, 2500–9000 RPM, in steps of 500 RPM
GRAPH RANGE, 2 minutes– 8 hours in the following steps,
2MINS, 10MINS, 30MINS, 60MINS, 2HRS, 4HRS, 8HRS

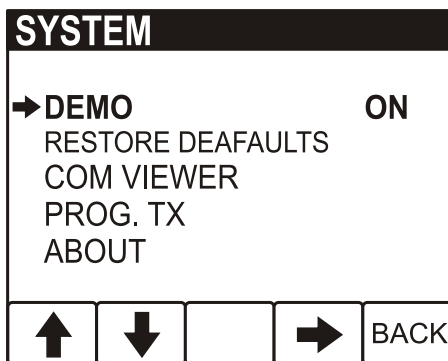

P0014213

SYSTEM

- DEMO, switches the DEMO mode ON/OFF.
- RESTORE DEEFAULTS, reset all configuration to default values.
- COM VIEWER, displays latest message on communication ports
- PROG TX, transfers content of the application on Flash memory to other CAN units on the same CAN bus.
- ABOUT, displays
ID NO – display serial number
EEPROM – number of write on EEPROM
VERS – software version number
CHK – Flash memory checksum
PART No – Volvo software part number
SOURCE – source of received data
LABEL – Allocated Label on the same bus.

CIU (Control Interface Unit)

The CIU is a "translator" between the control unit (EMS) and the customer's own control panel. The CIU has two serial communication links, one fast and one slow.

The fast one is a so-called CAN link. All data related to instruments, indication lamps, connectors and potentiometers is controlled by this link.

The slow link manages diagnostic information for flashing codes etc.

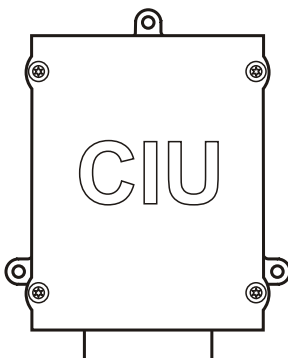

P0002060

Easy Link Instruments

The following Easy Link instruments are available:

- Tachometer / hours counter (fault codes are also displayed on the tachometer display when the diagnostic button is pressed)
- Coolant temperature
- Oil pressure
- Oil temperature
- Battery voltage
- Alarm panel
- Turbo pressure

Starting

Make it a habit of giving the engine and engine room a visual check before starting. This will help you to discover quickly if anything abnormal has happened, or is about to happen. Also check that instruments and warning displays show normal values after you have started the engine.

⚠ WARNING!

Never use start spray or similar agents to start an engine. This may cause an explosion in the inlet manifold. Risk of personal injury.

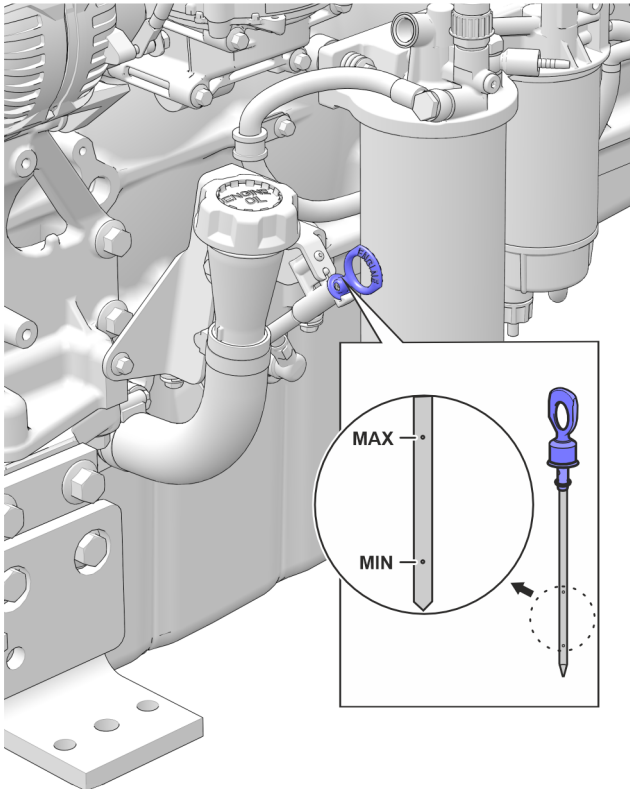

P0039034

Before Starting

- Check that the oil level is between the MIN and MAX marks.
For filling refer to *Oil level, checking and topping up*.

NOTICE! The engine should be placed on a level position when the oil is checked. Dipstick can be read when the engine is stopped.

- Open the fuel valves.
- Check the fuel pre-filter; refer to *Draining condensate, fuel system, page 72*.
- Check the coolant level and that the radiator is not blocked externally. Refer to *Coolant Level, Checking and Topping Up, page 77* and *Charge Air Cooler, External Cleaning, page 79*

⚠ WARNING!

Do not open the coolant filler cap when the engine is hot, except in emergencies, as this could cause serious personal injury. Steam or hot fluid could spray out.

- Check that no leakage of oil, fuel or coolant is present.
- Turn the main switch(es) on.
- Move the engine speed control to idle, and open the disengageable clutch/gearbox if installed.

IMPORTANT:

Never break the circuit with the main switch while the engine is running. Alternator and electronics could be damaged.

Starting the Engine

The pre-heating time (optional) is adjusted to suit the engine temperature, and can last for up to 50 seconds both before and after starting.

The starter motor cranking time is maximized to 20 seconds. After that, the starter motor circuit is temporarily cut to protect the starter motor from overheating.

DCU (Display Control Unit)

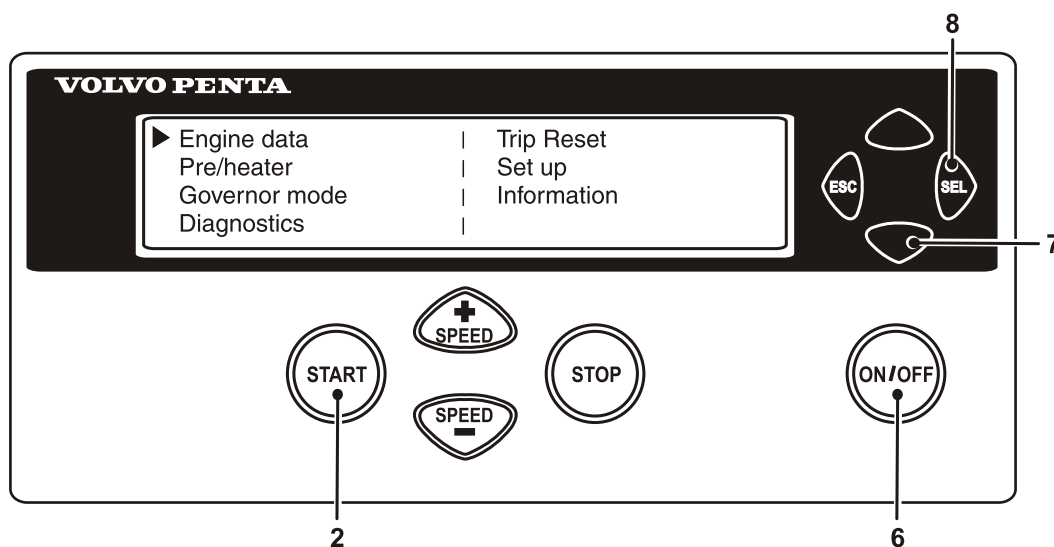

P0002079

With pre-heating

- 1 Depress the **ON/OFF**-button (6).
- 2 Press the **SEL** button (8) to come to the main menu.
- 3 Scroll down to **Pre/heater** with scroll button (7), press **SEL**-button (8)
- 4 In the **pre-heater** menu, press the **SEL**-button (8) to select pre-heating.
- 5 Press the **START**- button (2).



P0018811

Without pre-heating

- 1 Depress the **ON/OFF**-button (6).
- 2 Press the **START**-button (2).

Leave the engine to idle for the first 10 seconds. Then warm the engine up at low speed and under low load. Never race the engine when it is cold.

- 1 Press the **ON/OFF** button to switch on the ignition. The display switches on at the same time.
- 2 If preheat is activated, wait until heating icon has disappeared until **START** is requested.
- 3 Press the **START** button to start the engine.

Starting in Extreme Cold

Certain preparations must be made to enable engine starting in extreme cold, and in some cases to make starting possible at all:

- Use a winter grade fuel (of a well-known make) that is approved for the prevailing temperature. This reduces the risk of paraffin wax precipitation in the fuel system. At extremely low temperatures, we recommend the use of a fuel heater.
- Use a synthetic engine oil of a viscosity recommended for the prevailing temperature to achieve satisfactory lubrication. Refer to *Viscosity, page 90*. Synthetic lubricants are able to handle a wider temperature range than mineral-based lubricants.
- Pre-heat the coolant with a separately-installed electric engine heater. In extreme cases, a diesel-fired engine heater may be necessary. Ask your Volvo Penta dealer for advice.
- Make sure the cooling system is filled with a coolant mixture. Refer to , *page 76*.
- The batteries must be in good condition. Cold weather reduces battery capacity. Increased battery capacity may be necessary.

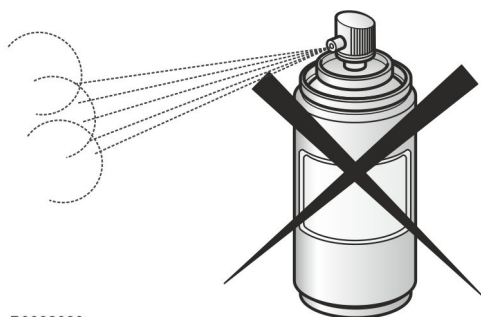

P0002080

Never Use Start Spray

⚠ WARNING!

Never use start spray or similar agents to start an engine. This may cause an explosion in the inlet manifold. Risk of personal injury.

Starting Using Auxiliary Batteries

⚠ WARNING!

Explosion hazard. Batteries contain and give off an explosive gas which is highly flammable and explosive. A short circuit, open flame or spark could cause a violent explosion. Ventilate well.

- 1 Check that the auxiliary batteries are connected (series or parallel) so that the rated voltage corresponds to the engine system voltage.
- 2 First connect the red (+) jumper cable to the auxiliary battery, then to the flat battery. Then connect the black (-) jumper cable to the auxiliary battery and to a location that is **somewhere away from the discharged battery**, e.g. the main switch negative terminal or the negative terminal on the starter motor.
- 3 Start the engine.

⚠ WARNING!

Do not touch the connections during the start attempt: Risk of arcing.
Do not bend over any of the batteries either.

- 4 Remove the cables in the reverse order.

IMPORTANT:

The ordinary cables to the standard batteries must not under any circumstances be loosened.

Operation

Correct operating technique is very important for both fuel economy, environmental protection and engine life. Always let the engine warm up to normal operating temperature before operating at full power.

Reading the Instruments

Check all instruments directly after starting, and then regularly during operation.

NOTICE! On engines in continuous operation, it is recommended that the lubrication oil level is checked at least every 24 hours. Refer to *Oil level, checking and topping up*.

Alarms

If the Control Unit receives abnormal signals from the engine, the control unit generates fault codes and alarms, in the form of lamps and audible warnings. This is done by means of CAN signals to the instrument.

More information about fault codes and fault tracing can be found in the chapter , *page 46*.

Maneuvering

Operation at low load

Avoid long-term operation at idle or at low load. It takes a long time for the engine to reach working temperature, resulting in high viscosity of the oil and large clearances in the engine mechanics. In cold climate, it takes even longer.

The combustion temperature and cylinder pressure can become so low that an effective combustion cannot be ensured. At these conditions unburned fuel could dilute the lubricant oil. Because of the low cylinder pressure, the piston ring performance could be affected causing oil from the crankcase to pass the rings and go further out with the exhaust gases. This mixture of unburned fuel and oil in exhaust gases is referred to as "slobber". A new engine produces more "slobber" at low load compared to an engine with more hours of operation.

At low load, the pressure in the turbocharger is low and oil could seep past the turbocharger seals and mix with the air into the engine. The consequences can be carbon build-up on valves, piston crowns and the exhaust turbine, which could affect engine performance.

Both conditions can lead to increased oil consumption and eventually external oil leakage from joints in the exhaust system. For example, leakage could be seen at the exhaust manifold, before and after the turbo, around the muffler and in worse case even in the exhaust end pipe. Consequences could lead to clogged exhaust gas recirculation systems and exhaust aftertreatment systems.

Signs of oil leaking caused by "slobber" do not indicate an engine problem but indicates low load operation. To minimize the risk of malfunctions caused by operation at low load, follow these points as a complement to normal maintenance:

- Run in the engine as soon as possible.
- Load the engine so it reaches working temperature as soon as possible.
- For VE: Turn off the engine instead of running on idle for longer periods.
- For genset turn off the engine instead of running unloaded for longer periods.
- Avoid load levels below 20% as constant operation.
- If the engine is regularly tested without load, limit the duration of the operation to 5 minutes. Run the engine at full load for about 4 hours once a year, for the carbon deposits in the engine and exhaust system to burn off.

- If visible slobber has occurred, it can be burned off by running the engine on at least 30% load for about 40-60 minutes.

Engine Shutdown

During longer breaks in operation, the engine must be warmed up at least once every two weeks. This prevents corrosion in the engine. If you expect the engine to remain unused for two months or more, it must be preserved: Refer to the chapter , page 86.

Before Engine Shutdown

Let the engine run at high idle (1500 or 1800rpm) for a minimum of 5 minutes before the shutdown after normal use. Normal use is defined as minimum 50% load. After use with less than 50% load, high idle for approximately 3 minutes is sufficient. This allows engine temperature equalization and prevents boiling once stopped and also allows the turbochargers to cool down. This contributes to long, fault-free service life.

NOTICE! Do not turn off the main switch within 30 seconds after turning off the ignition. This is in order to save engine data to the engine control unit.

Stop the Engine

- Disengage the clutch (if possible).
- Depress the **STOP**-button (5).

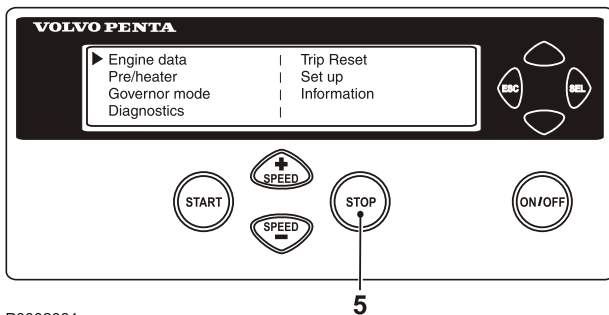

P0002081



P0018811

- 1 Disengage the clutch, if possible.
- 2 Press the STOP button to turn off the engine.
- 3 Press the  button to turn off the ignition.



P0025697

Auxiliary Stop

For location of the extra stop, refer to , *page 59*.

WARNING!

Working with or approaching a running engine is a safety risk. Watch out for rotating components and hot surfaces.

After Engine Shutdown

- 1 Check the engine and engine compartment for leaks.
- 2 Turn off the main switches before any long stoppage.
- 3 Carry out maintenance in accordance with the schedule.

For longer breaks in operation

During longer breaks in operation, it is recommended that the engine is warmed up at least once every two weeks. This prevents corrosion in the engine.

If you expect the engine to be unused for two months or more, it should be conserved. Refer to , *page 86* .

IMPORTANT:

If there is a risk of freezing, the coolant in the cooling system must have adequate antifreeze protection.

Refer to , *page 76*.

IMPORTANT:

A poorly charged battery can freeze and burst.

Refer to *Battery*, *page 84*.

Fault handling

Despite regular service in accordance with the planned maintenance schedule and perfect operating conditions, faults may occur that must be remedied before operations continue. This chapter describes the diagnostics function.

Diagnostic Function

The purpose of the diagnostic function is to monitor, control and protect the engine and its surrounding system and components from damage, as well as to ensure a minimal environmental impact.

If a malfunction is detected the diagnostic function informs of the occurred fault in the form of a fault code. The fault code provides guidance when fault tracing. All fault codes and fault messages can be found in the *Fault Code Register*.

The operator is warned that there is a malfunction via the instruments. Depending on the instrumentation in use, the fault message is shown in various ways. Fault codes can also be read out by the Volvo Penta diagnostic tool.

Depending on the severity of the fault, the diagnostic function will take various actions to protect the engine and limit emissions (e.g. torque derate, idle speed only, engine shut down etc.)

DCU (Display Control unit)

- 1 When a fault is detected the following text is displayed:
!! ENGINE WARNING !! alternating with **Press SEL for information.**
- 2 Reduce engine speed to idle or shut down the engine.
- 3 Press the **SEL** button to get to the fault list.
The fault list shows:
 - hours of operation
 - fault messages
 - active/non-active faults
- 4 Look up the fault code in the *Fault Code Register* and take the necessary actions.
- 5 Press **ESC** to leave the fault list.

NOTICE! To get to the fault list when no fault codes are set, press the **SEL** button and select **Diagnostics** from the menu.

Eng speed	1800 rpm	Boost prs	4 kpa	▲
Cool Temp	85 °C	Boost tmp	59 °C	
Oil Pres	480 kpa	Oil Temp	87 °C	
!! ENGINE WARNING !!				
▼				

Eng speed	1800 rpm	Boost prs	4 kpa	▲
Cool Temp	85 °C	Boost tmp	59 °C	
Oil Pres	480 kpa	Oil Temp	87 °C	
Press SEL for information				
▼				

P0020406

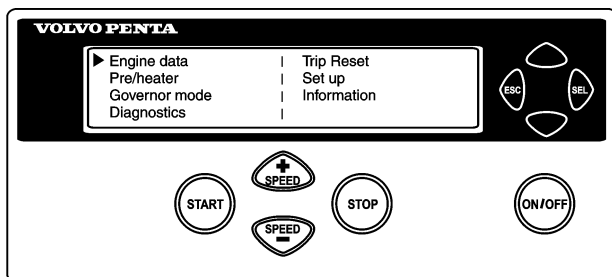

P0014039

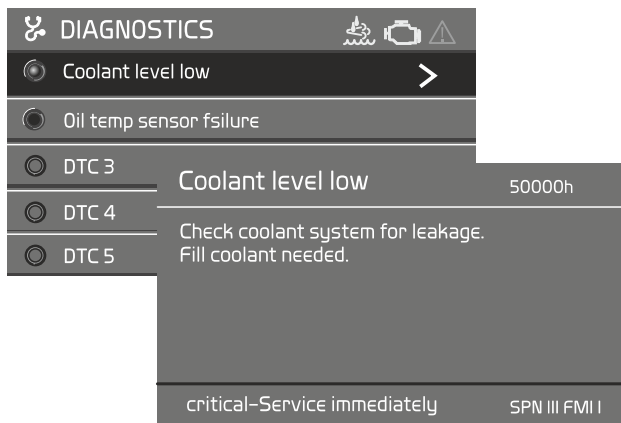

P0018293

DCU II (Display Control Unit)

DIAGNOSTICS

If the system detects a malfunction the driver/operator is informed via a pop-up message on the display. The fault codes are listed in the diagnostics menu; active fault codes are at the top of the list and are denoted by a green dot. For more detailed information regarding the cause and remedies, use the arrow buttons to scroll to the fault concerned and press **OK**. This will also provide information about the number of engine hours when the fault became active and the SPN and FMI codes.

DU (Display Unit)

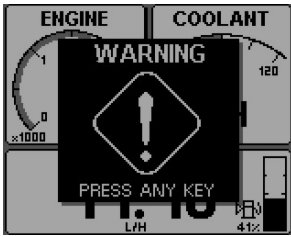
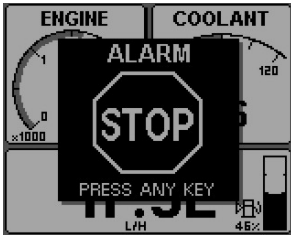

P0014030

- 1 If the system detects a fault, a pop-up is shown on the display. Depending on the severity of the fault the following text will appear
ALARM STOP / PRESS ANY KEY or
WARNING! / PRESS ANY KEY; a buzzer will sound.
- 2 Reduce engine speed to idle or shut down the engine.

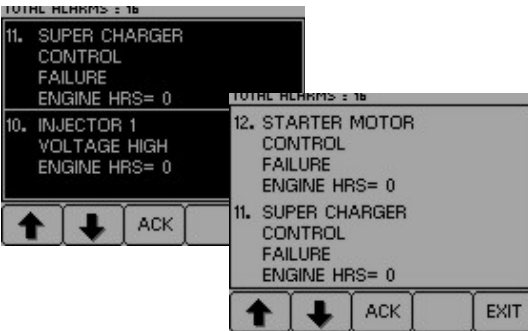

P0014029

- 3 Press the SEL button to get to the fault list. The fault list shows fault messages and the number of hours of operation when the fault occurred.
- 4 Press **ACK** to acknowledge the fault code. The display background changes color (and the buzzer stops). The fault must be acknowledged before it can disappear from the fault list.
- 5 Look up the fault code in the *Fault Code Register* and take the necessary actions.

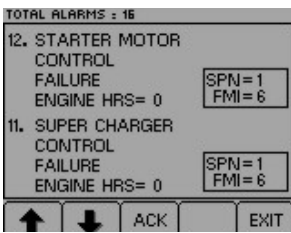

P0014038

- 6 Press button 4 for at least three seconds to view SPN and FMI codes.
- 7 Press **EXIT** to leave the fault list.

CIU (Control Interface Unit)

When the system detects a malfunction, the diagnostics lamp flashes. If the diagnostics button is pressed and then released, a fault code is flashed out.

The fault code consists of two groups of flashes, separated by a pause of two seconds. A fault code is obtained by counting the number of flashes in each group.

Example

•• pause •••• = fault code 2.4

The fault code is stored and can be read off as long as the malfunction remains. Information about causes, effects and actions required is available in the Fault Code chapter.

Do as follows to read off the fault code:

- 1 Press the diagnostics button.
- 2 Release the diagnostics button and note down the fault that is flashed out.
- 3 Repeat items 1–2. A new fault code will be flashed out if more faults are stored. Repeat until the first fault code reappears.

NOTICE! When the first fault code reappears, all fault codes have been read off.

If the diagnostics button is pressed after the fault has been rectified and the fault codes have been erased, code 1.1 “No fault” will be displayed.

Easy Link Instruments

- 1 When a malfunction is detected this is reported by the diagnostic lamp which starts to flash.
- 2 Press the diagnostics button. The fault code is shown as text in the tachometer display.
- 3 Look up the fault code in the *Fault Code Register* and take the necessary actions.
- 4 When the fault has been rectified, the fault code disappears from the display and the diagnostics lamp goes out.

Erasing fault codes

The memory of the diagnostic function is reset when the power to the engine is disconnected. When the power is switched on again, the diagnostic function will check if there are any malfunctions in the system. If so a new fault codes is registered.

If a malfunction has not been corrected it will be registered once again and has to be acknowledged again.

Fault Tracing

A number of symptoms and possible causes of engine malfunctions are described in the table below. Always contact your Volvo Penta dealer if any problems occur which you can not solve by yourself.

IMPORTANT!

Read through the safety advice for care and maintenance work in the chapter *Safety precautions for maintenance and service operations* before you start work.

Symptoms and possible causes

The diagnosis button lamp flashes	Please refer to <i>Diagnostic Function</i>
Engine can not be stopped	2, 5
Starter motor does not rotate	1, 2, 3, 4, 5, 6, 7, 24
Starter motor rotates slowly	1, 2
Starter motor rotates normally but engine does not start	8, 9, 10, 11,
Engine starts but stops again	8, 9, 10, 11, 13
Engine does not reach correct operating speed at full throttle	9, 10, 11, 12, 13, 21, 25, 26
Engine runs roughly	10, 11
High fuel consumption	12, 13, 15, 25
Black exhaust smoke	12, 13
Blue or white exhaust smoke	15, 22
Too low lubrication oil pressure	16
Excessive coolant temperature	17, 18, 19, 20, 28
Too low coolant temperature	20
No, or poor charge	2, 23
Too high exhaust temperature TWD1643GE, TWD1652/53	13, 17, 18, 19, 21, 25, 27, 28, 29, 30

- 1 Discharged batteries
- 2 Poor contact/open circuit in electrical wiring
- 3 Main switch turned off
- 4 Main fuse faulty
- 5 Faulty ignition lock
- 6 Faulty main relay
- 7 Faulty starter motor/-solenoid
- 8 No fuel:
 - fuel cocks closed
 - fuel tank empty/wrong tank connected
- 9 Blocked fuel fine-filter/pre-filter (due to contaminations, or stratification in the fuel at low temperature)
- 10 Air in the fuel system
- 11 Water/contamination in fuel
- 12 Faulty fuel injectors
- 13 In sufficient air supply to the engine:
 - blocked air filter
 - air leakage between the turbo and the engine's intake manifold
 - dirty compressor part in the turbocharger
 - faulty turbo compressor
 - poor engine room ventilation
- 14 Coolant temperature too high
- 15 Coolant temperature too low
- 16 Oil level too low
- 17 Coolant level too low
- 18 Air in the coolant system
- 19 Faulty circulation pump
- 20 Defective thermostat
- 21 Blocked charge air cooler
- 22 Oil level too high
- 23 Alternator drive belt slips
- 24 Water entry into engine
- 25 High back pressure in the exhaust system
- 26 Break in "Pot+" cable to throttle
- 27 High temperature, charge air cooler
- 28 Blocked radiator
- 29 No pressure in cooling system
- 30 Check wastegate function

Fault Code Register

TAD1640VE-C, TAD1641VE-C, TAD1642GE-B, TAD1642VE-C, TAD1643VE, TAD1643VE-B, TAD1650GE, TAD1650VE, TAD1650VE-B, TAD1651GE, TAD1651VE, TWD1643GE, TWD1644GE, TWD1645GE, TWD1652GE, TWD1653GE

	SPN	PID	PPID	SID	PSID	Flash code Electrical fault/Value fault	FMI
Coolant Water Pressure	20	20					1,3,4,5,18
Percent Accelerator Pedal Position	91	91				2.7/- (EMS) 2.8/- (CIU)	9
Fuel Delivery Pressure , page 72	94	94				3.6/3.8	1, 3, 5, 7
Water in fuel indicator <i>Draining condensate, fuel system, page 72</i>	97	97				2.9/2.1	0, 3, 4
Engine Oil Level <i>Oil level, checking and topping up, page 69</i>	98	98				5.9/5.7	1, 3, 4, 5
Engine Oil Filter Differential Pressure	99						0
Engine Oil Pressure <i>Oil level, checking and topping up, page 69</i>	100	100				3.1/6.6	1, 3, 5, 18
Boost pressure	102	102					0, 3, 5, 16
Boost temperature	105	105				3.2/6.2	0, 4, 5, 16
Boost pressure	106	106				3.4/3.5	0, 3, 5, 16
Air filter pressure	107	107				5.5/5.5	0, 3, 4, 5
Ambient air pressure	108	108				-/-	2, 3, 4
Coolant Temperature <i>Coolant Level, Checking and Topping Up, page 77</i>	110	110				3.3/6.1	0, 4, 5, 16
Coolant Level <i>Coolant Level, Checking and Topping Up, page 77</i>	111	111				2.3/2.2	1, 3, 5
Crankcase pressure	153	153				7.8/7.7	0, 2, 3, 5
Battery voltage <i>Battery, Charging</i>	158	158				-3.9 (EMS) -6.9 (CIU)	1, 3, 4
Injection control pressure	164	164				8.3	2, 4, 5
Ambient Air Temperature Sensor	171	171					14
Ambient Air Temperature Sensor	172	172				7.9/-	4, 5
Engine Oil Temperature <i>Oil level, checking and topping up, page 69</i>	175	175				3.7/5.8	0, 4, 5, 16
Engine Speed	190	190				-/2.6	0, 16
Throttle position	608		98			-/-	9
Throttle calibrated position	608		132			2.8/-	9
SAE J1708 Data Link	608			250		9.2/-	
SAE J1939 Data Link	608				201		9
+5 V sensor supply	620			232		9.3/-	3, 4
Inlet Air Temperature	626	45				5.4/-	3, 4, 5

	SPN	PID	PPID	SID	PSID	Flash code Electrical fault/Value fault	FMI
Program Memory	628			240		9.9/-	2, 12
Controller error	629			254		9.9/- (EMS) 9.8/- (CIU)	8, 12
Calibration Memory EEPROM	630			253		9.9/- (EMS) 9.8/- (CIU)	2, 12, 14
Camshaft sensor	636			21		2.5/-	2, 3, 8
Flywheel sensor	637			22		2.4/-	2, 3, 8
SAE J1939 Data Link	639			231		6.5/- (EMS) 6.4/- (CIU)	2
Engine Fan Driver	647			33			3, 4, 5
Fuel Injector, Cylinder #1	651			1		7.1/-	3, 4, 5, 12
Fuel Injector, Cylinder #2	652			2		7.2/-	3, 4, 5, 12
Fuel Injector, Cylinder #3	653			3		7.3/-	3, 4, 5, 12
Fuel Injector, Cylinder #4	654			4		7.4/-	3, 4, 5, 12
Fuel Injector, Cylinder #5	655			5		7.5/-	3, 4, 5, 12
Fuel Injector, Cylinder #6	656			6		7.6/-	3, 4, 5, 12
Starter motor relay	677			39		4.6/-	3, 4, 5
Injection Control Pressure Regulator	679				42	8.3/-	3, 4, 5, 6,
Pressure Release Valve	679				97	8.3	0, 7, 11, 14
Starter element	729			70		8.6	3, 4, 5
Stop Input, EMS	970		6			4.8/- (EMS)	4
Fan speed	975	26					3
Compression break	1072		122				1, 3, 4, 5
+5 V sensor supply	1079			232		9.3/-	3, 4
+5 V sensor supply 2	1080			211		9.3/-	3, 4
ECU temperature high	1136		55			8.4	16
Exhaust gas temperature	1184	173				4.9/1.9	0, 4, 5, 16
Wastegate Valve	1188			32			3, 4, 5
SAE J1939 Data Link	1231				232		2
SAE J1939 Data Link	1231				229		9
Rail pressure system	1239				96	8.3	0, 1, 4, 7, 12, 16
Engine synchronizing	1377		98				9
Main relay output	1485		5			5.1/-	
Starter Output	1675		3				0, 3, 4, 5, 10
Starter Output	1675			39			0, 3, 4, 5, 10
Data link	2017				201		9
Internal EGR	2791		19			8.5	3, 4, 5, 7
Starter Output	2898		3				3, 4, 5
Starter Output	2899		3				3, 4
Thermostat bypass valve	2988		332				3, 4, 5

	SPN	PID	PPID	SID	PSID	Flash code Electrical fault/Value fault	FMI
Exhaust gas temperature sensor #1	3241		386				0, 7, 4, 5
Sensor Supply Voltage #1 (+5 V DC)	3509			232			3, 4
Sensor Supply Voltage #2 (+5V DC)	3510			211			3, 4
Piston cooling oil pressure	4811		8				1, 2, 3, 5, 18
Piston cooling pressure	520192					6.8/6.7	1, 3
Starter input sensor	520194		4			4.7/- (EMS) 5.2/- (CIU)	
Stop Input, CIU	520195		6			5.3/- (CIU)	4
Frequency select input			113				
Diagnostic request switch input			259				
Oil pressure warning lamp status			260			4.1/-	
Coolant level warning lamp status			261			4.5/-	
Diagnostic lamp status			262				
Run indication lamp status			263			4.3/-	
Over speed indication lamp status			264			4.4/-	
Coolant temperature warning lamp output			7			4.2/-	

Fault codes, engine

SPN	Component	FMI
20	Coolant Water Pressure	1, 3, 5, 18
51	Engine Throttle position (cold)	3, 5, 7, 12, 13
91	Accelerator Pedal position	0, 9, 19
94	Fuel Delivery Pressure <i>, page 72</i>	3, 5, 12, 18
97	Water in fuel indicator <i>Draining condensate, fuel system, page 72</i>	0, 4, 12
98	Engine Oil Level <i>Oil level, checking and topping up, page 69</i>	1, 4, 5, 18
99	Engine Oil Filter Differential Pressure	0
100	Engine Oil Pressure <i>Oil level, checking and topping up, page 69</i>	1, 3, 4, 5, 18
101	Crankcase pressure	0, 3, 5
102/106	Boost pressure	0, 3, 4, 5, 16
105	Boost temperature	0, 4, 5, 16
107	Air filter pressure	0, 3, 4, 5, 12
108	Ambient air pressure	5
110	Coolant Temperature <i>Coolant Level, Checking and Topping Up, page 77</i>	0, 4, 5, 16
111	Coolant Level <i>Coolant Level, Checking and Topping Up, page 77</i>	1, 3, 4, 5, 18
131	Exhaust back pressure	3, 5, 12
153	Crankcase pressure	0, 2, 3, 5
158	ECU battery potential <i>Battery, Charging</i>	0,1, 2
164	Injection control pressure	2, 4, 5
171	Ambient Air Temperature Sensor	14
172	Ambient Air Temperature Sensor	4, 5
173	Exhaust gas temperature	0, 16
175	Engine Oil Temperature <i>Oil level, checking and topping up, page 69</i>	0, 3, 4, 5, 16
190	Engine Speed	0, 16
608	Throttle position	9
626	Preheat relay	3, 4, 5
626	Inlet Air Temperature	3, 4, 5
628	Program Memory	2
629	Controller error	8, 12
636	Camshaft sensor	7, 8, 9
637	Crankshaft sensor	2, 8, 9
639	J1939 Network #1 Primary Vehicle Network	2
647	Engine Fan Driver	3, 4, 5
651	Fuel Injector, Cylinder #1	3, 5
652	Fuel Injector, Cylinder #2	3, 5
653	Fuel Injector, Cylinder #3	3, 5
654	Fuel Injector, Cylinder #4	3, 5
655	Fuel Injector, Cylinder #5	3, 5

SPN	Component	FMI
656	Fuel Injector, Cylinder #6	3, 5
677	Starter motor relay	3, 4, 5, 6
679	Injection Control Pressure Regulator	3, 4, 5, 6
679	Pressure Release Valve	0, 7, 11, 14
729	Preheater	5, 6, 7, 12
970	Engine stop switch	3, 4, 5, 11, 14
1136	ECU temperature high	16
1184	Exhaust gas temperature	0, 4, 5, 16
1188	Wastegate Valve	3, 4, 5
1485	ECM Main Relay	7
1639	Fan speed	3
1668	J1939 Network #4 (engine subnet)	2
2017	Lost Communication (Source Address 17)	9
2036	Lost Communication (Source Address 36)	9
2659	Engine Exhaust Gas Recirculation (EGR) Mass Flow Rate	18
2791	Internal EGR	7
2988	Thermostat bypass valve	3, 4, 5
3241	Exhaust gas temperature	19
3364	Aftertreatment Tank Reagent Quality	2, 17
3464	Engine throttle actuator (cold) Engine Throttle Actuator	3, 4, 5, 7, 10, 12
3509	Sensor Supply Voltage #1 (+5 V DC)	3, 4
3510	Sensor Supply Voltage #2 (+5V DC)	3, 4
3511	Sensor Supply Voltage #3 (+5V DC)	3, 4
520193	Sea Water Pressure	1, 3, 4, 5, 18
520335	ECU battery potential	5
520416	Lost communication with reductant control module on engine subnet	9
520567	Aftertreatment Exhaust Temperature - Wet	0, 3, 4, 5, 16
520570	Engine Oil Pressure Before Filter	3, 4, 5, 11
520688	Aftertreatment Exhaust Temperature - Dry	0, 3, 4, 5, 16
520689	EGR "A" / Volvo Compression Brake (VCB) Control Circuit	3, 4, 5
520690	EGR "A" Control / Turbocharger/Supercharger Wastegate Solenoid "A"	3, 5
520691	Torque Speed Control 1 Received With Errors (Counter or Checksum)	14

Maintenance Schedule

Your Volvo Penta engine and its equipment are designed for high reliability and long life. The engines are built to have the smallest possible environmental impact. If given preventive maintenance, according to the maintenance schedule, these qualities will be retained and unnecessary malfunctions will be avoided. In order for the warranty to be valid, the owner must make sure that the services in the service intervals are performed.

NOTICE! For emission related warranty rights see Emission Control System Warranty Statement.

Service Intervals

Service intervals and the service content can be found in the Service Protocol available for download at www.volvopenta.com.

Where both operational and calendar times are specified, perform the maintenance item at whichever time is the sooner.

NOTICE! More information on how to perform service and maintenance can be found in the Service and Maintenance handbook. Information on how to download or purchase the Service and Maintenance handbook can be found at www.volvopenta.com.

Extended service intervals

The interval between engine oil changes may be extended in certain circumstances. To determine whether the service interval may be extended, Volvo Penta's conditions for extended service intervals must be met and an oil analysis performed. Contact your Volvo Penta dealer for further information.

Maintenance

This chapter describes the most common maintenance items. Refer to *Maintenance Schedule* for service intervals. When ordering service or spare parts, always specify the engine and transmission identification number. Refer to , page 96.

NOTICE! More information on how to perform service and maintenance can be found in the Service and Maintenance handbook. Information on how to purchase the Service and Maintenance handbook can be found at www.volvopenta.com.

⚠ CAUTION!

Read through the safety advice before starting any work.

⚠ WARNING!

Care and maintenance work should be done with the engine stopped unless otherwise specified. Stop the engine before opening or removing the engine hatch/hood. Make it impossible to start the engine by removing the start key and cutting the system voltage with the main switches.

Orientation

TAD1643VE-B

- 1 Control unit, EMS
- 2 Fuel pre-filter with water separator
- 3 Fuel filter
- 4 Oil dipstick
- 5 Oil filler cap
- 6 Alternator
- 7 Oil filter
- 8 Turbo

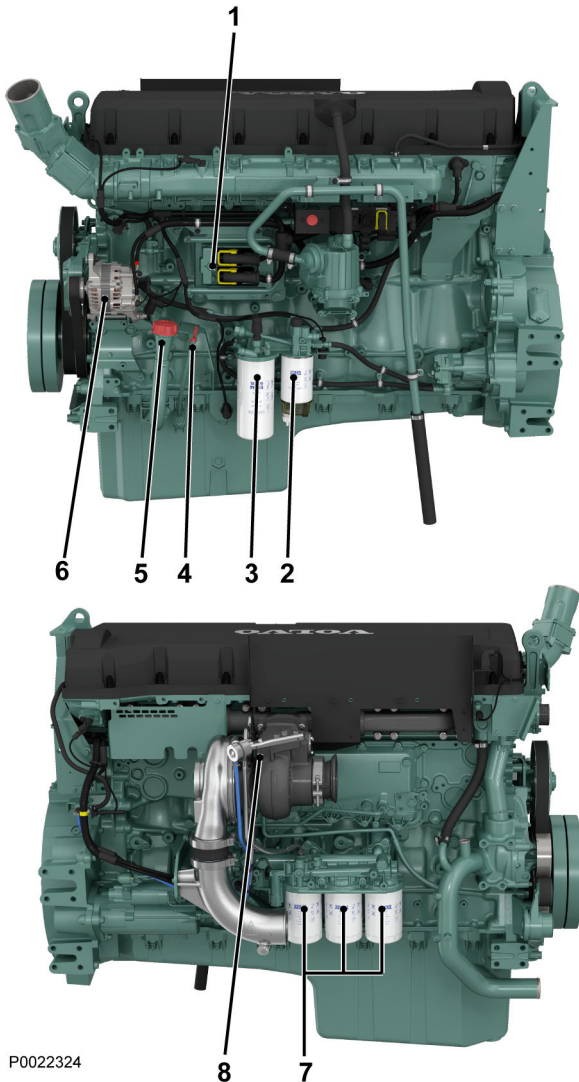

TAD1640VE-C, TAD1641VE-B, TAD1641VE-C,
TAD1642GE-B, TAD1642VE-C, TAD1643VE

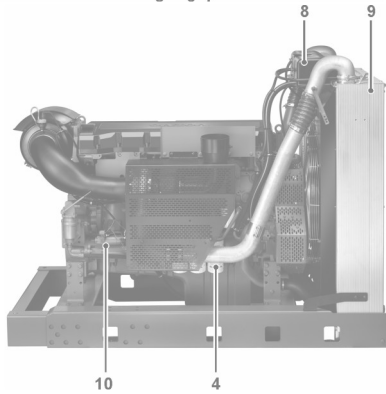
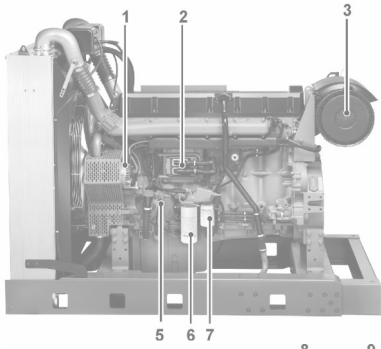

P0014600

- 1 AC generator
- 2 Control unit EMS 2
- 3 Air Filter
- 4 Oil filter
- 5 Oil dipstick
- 6 Fuel filter, with fuel pressure monitor
- 7 Fuel prefilter with water monitor
- 8 Expansion tank
- 9 Radiator
- 10 Starter motor

TWD1643GE, TWD1644GE, TWD1645GE,
TWD1652GE, TWD1653GE

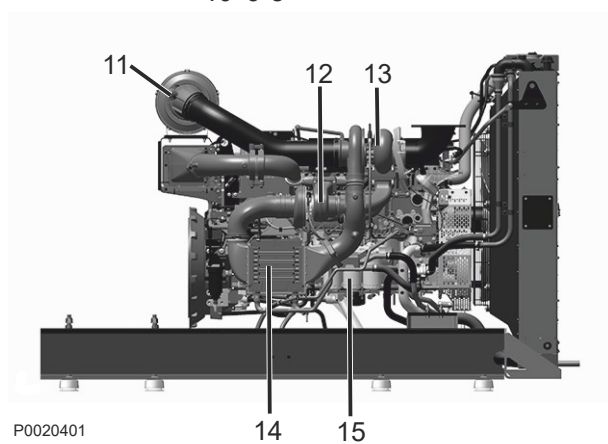
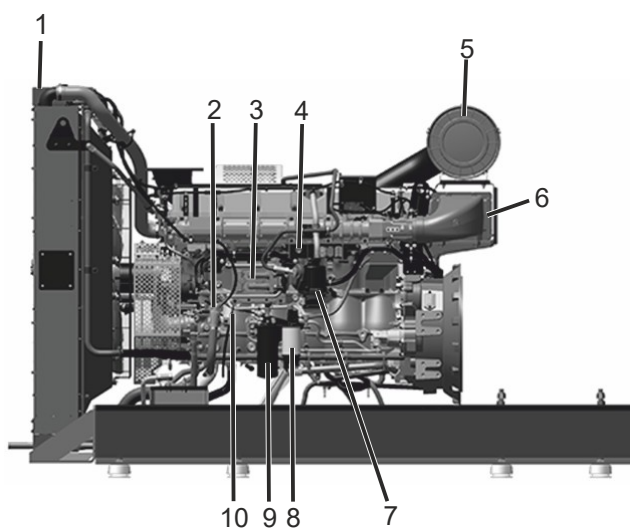

P0020401

- 1 Expansion tanks
- 2 Oil filler cap, engine
- 3 Control Unit, EMS
- 4 Auxiliary Stop
- 5 Air Filter
- 6 Charge air cooler (High-Pressure Turbo)
- 7 Crankcase ventilation
- 8 Fuel filter, with fuel pressure monitor
- 9 Fuel prefilter with water monitor
- 10 Oil dipstick
- 11 Air filter indicator
- 12 Low-Pressure Turbo
- 13 High-Pressure Turbo
- 14 Charge air cooler (Low-Pressure Turbo)
- 15 Oil filter

TAD1650GE, TAD1650VE, TAD1651GE

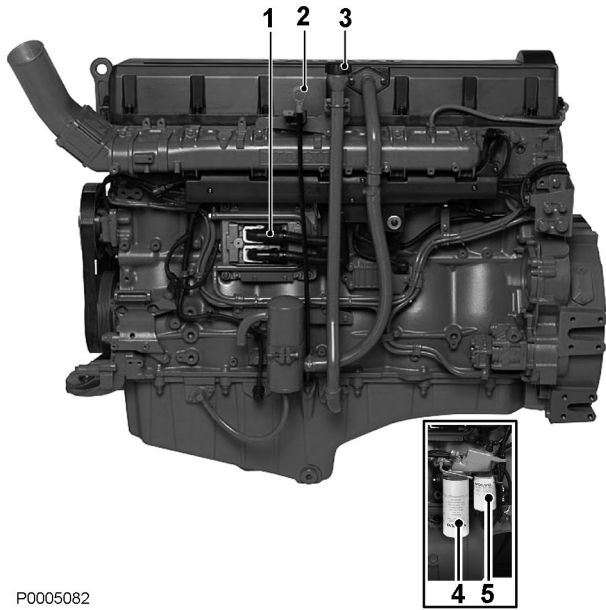

- 1 Control unit, EMS
- 2 Oil filler
- 3 Oil dipstick
- 4 Fuel filter, to be installed separately
- 5 Fuel pre-filter with water monitor, to be installed separately
- 6 Starter motor

P0005082

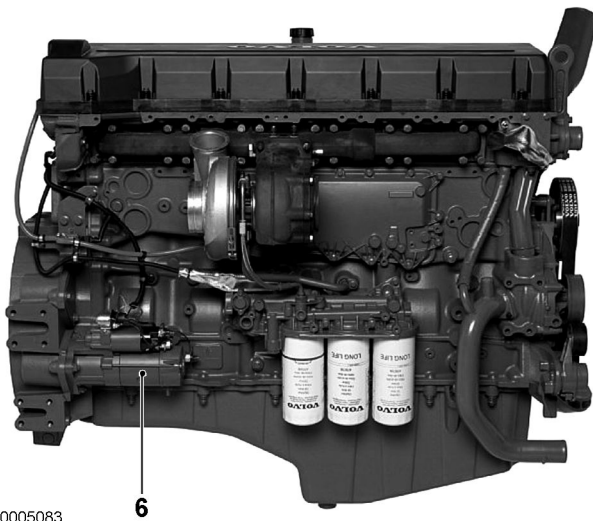

P0005083

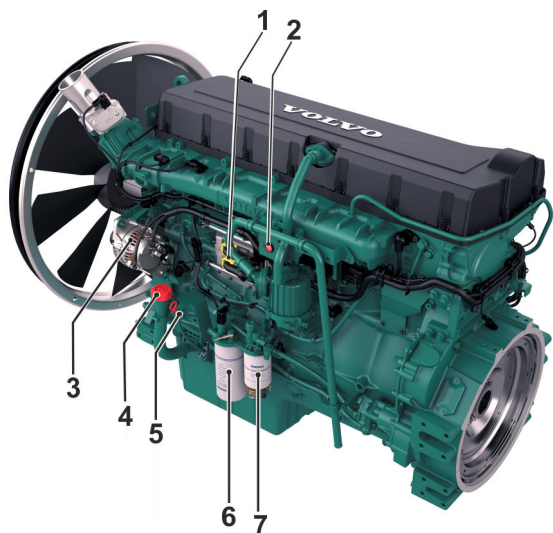

TAD1650VE-B, TAD1651VE

- 1 Control Unit, EMS
- 2 Auxiliary stop
- 3 Alternator
- 4 Oil filler cap, engine
- 5 Oil dipstick
- 6 Fuel Filter
- 7 Fuel pre-filter with water separator
- 8 Turbo
- 9 Starter motor
- 10 Oil filter

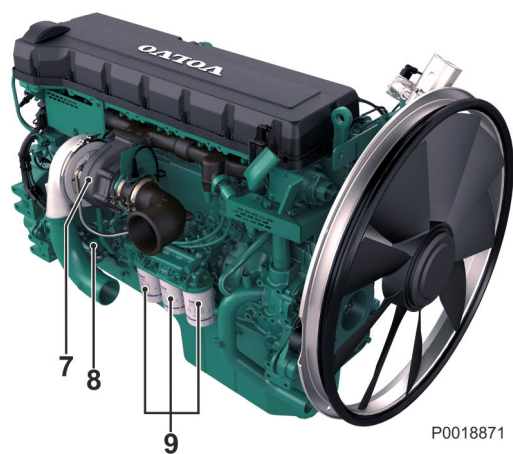

P0018871

Engine, General

General inspection

Make it a habit to give the engine and engine compartment a visual inspection before starting the engine and after operation once the engine has stopped. This will help you to discover quickly if anything abnormal has happened, or is about to happen.

Look especially carefully at oil, fuel and coolant leakage, loose bolts, worn or poorly tensioned drive belts, loose connections, damaged hoses and electrical cables. This inspection only takes a few minutes and can prevent serious malfunctions and expensive repairs.

⚠ WARNING!

Risk of fire.

Remove all accumulations of fuel, oil and grease when detected on the engine or in the engine room.

⚠ WARNING!

If an oil, fuel or coolant leak is detected, the cause must be investigated and the fault rectified before the engine is started.

IMPORTANT:

Washing with a power washer: Never aim the water jet at radiators, charge air cooler, seals, rubber hoses or electrical components.

Air Filter, Check and Replace

The engine is equipped with electronic air filter indication.

The control unit provides an output signal which is announced as a warning on the instrument panel. The warning indicates a pressure drop in the air filter, which must then be checked and possibly changed.

- Scrap the old filter. No cleaning or re-use is permissible
- In continuous operation, the filter should be checked every 8 hours. For operations in extremely dirty environments such as coal mines and rock crushing mills, special air filters must be used.

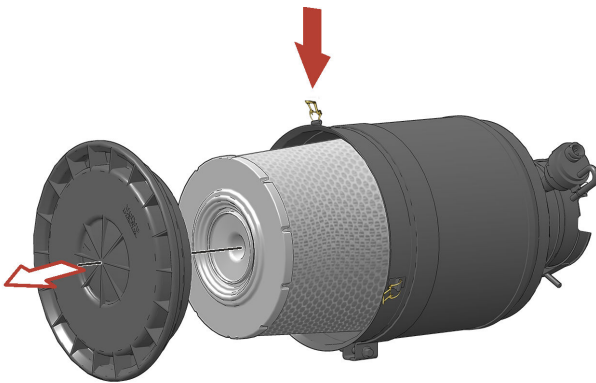

P0018636

Charge Air Pipe, Leakage Check

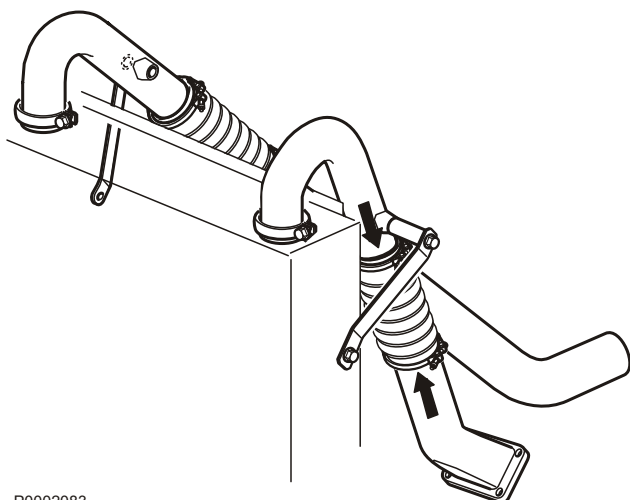

P0002083

Inspect the condition of the charge air hoses, hose unions and clamps for cracks and other damage. Change as necessary.

Clamps must be tightened using a torque wrench to 9 ± 2 Nm (6.6 ± 1.5 lbf.ft.).

Drive Belt and Alternator Belt, Inspection

WARNING!

Working with or approaching a running engine is a safety risk. Watch out for rotating components and hot surfaces.

IMPORTANT:

Always change a belt which looks worn or cracked.

Inspections must be carried out after operations, while the belts are hot.

You should be able to depress the alternator belt and the drive belt about 3-4 mm between the pulleys.

The alternator belts and drive belts have automatic belt tensioners and do not need to be adjusted.

Check the condition of the drive belts. Replace as necessary; refer to *Alternator Belt, Replace, page 67* and *Drive Belt, Replace, page 66*.

Drive Belt, Replace

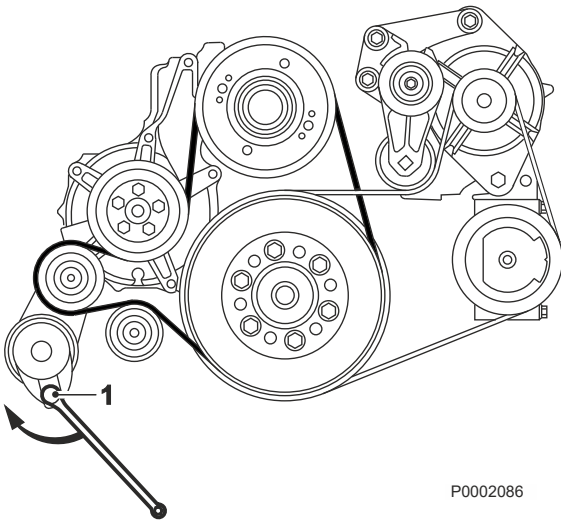

TAD1641GE-B, TAD1642GE-B, TAD1650GE, TAD1651GE,
TAD1640VE-C, TAD1641VE-C, TAD1642VE-C, TAD1643VE,
TAD1643VE-B, TAD1650VE, TAD1650VE-B, TAD1651VE

- 1 Disconnect the main switch(es) and check that the engine is not connected to system voltage.
- 2 Remove the fan guard and fan ring round the cooling fan.
- 3 Remove the belt guard.
- 4 Insert a 1/2" square wrench in the belt tensioner (1). Lift the wrench and remove the drive belt.
- 5 Thread the drive belt round the fan and remove it.
- 6 Check that the pulleys are clean and undamaged.
- 7 Thread the new drive belt over the fan.
- 8 Lift the 1/2" wrench and install the new drive belt.
- 9 Install the belt guards.
- 10 Install the fan guard and fan ring round the cooling fan.
- 11 Start the engine and do a function check.

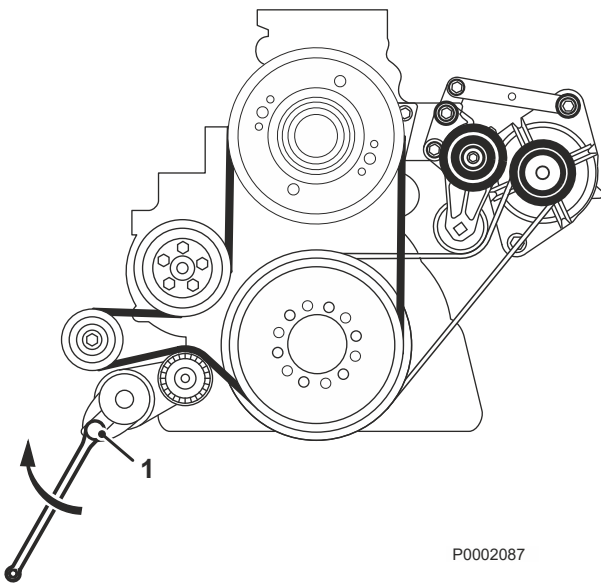

TWD1643GE, TWD1644GE, TWD1645GE, TWD1652GE,
TWD1653GE

Alternator Belt, Replace

IMPORTANT!

Always change a drive belt which appears worn or cracked.

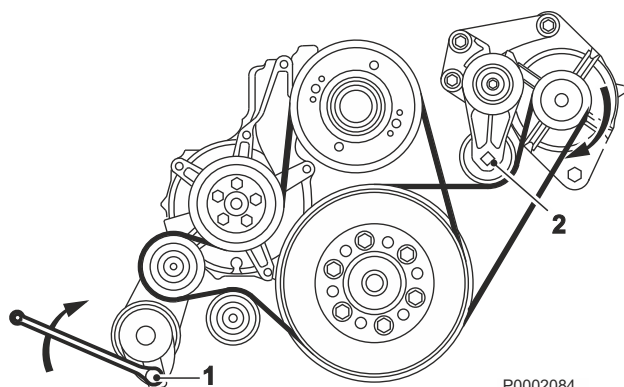

P0002084

TAD1641GE-B, TAD1642GE-B, TAD1650GE, TAD1651GE,
TAD1640VE-C, TAD1641VE-C, TAD1642VE-C, TAD1643VE,
TAD1643VE-B, TAD1650VE, TAD1650VE-B, TAD1651VE

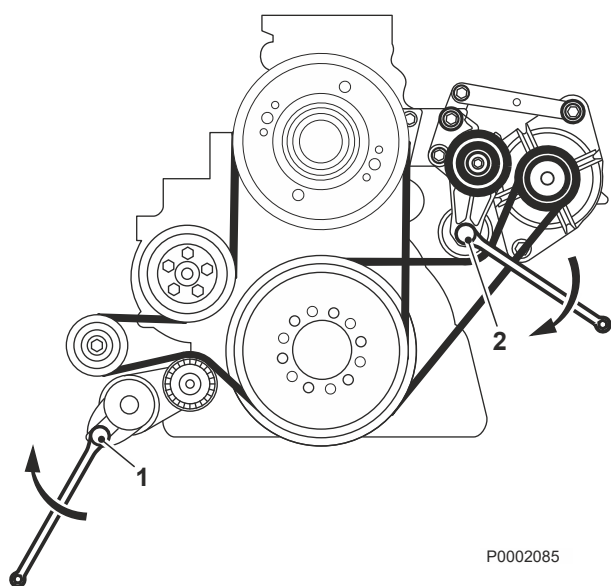

P0002085

TWD1643GE, TWD1644GE, TWD1645GE, TWD1652GE,
TWD1653GE

- 1 Disconnect the main switch(es) and check that the engine is not connected to system voltage.
- 2 Remove the fan guard and fan ring round the cooling fan.
- 3 Remove the belt guard.
- 4 Insert a 1/2" square wrench in the belt tensioner (1). Lift the wrench up and lift the water pump drive belt off.
- 5 Insert a 1/2" square wrench in the belt tensioner (2). Press the wrench down and remove the alternator belts.
- 6 Check that the pulleys are clean and undamaged.
- 7 Press the 1/2" wrench in the belt tensioner (2) down and install the new alternator drive belt.
- 8 Lift the 1/2" wrench in the belt tensioner (2) and install the new water pump drive belt.
- 9 Install the belt guards.
- 10 Install the fan guard and fan ring round the cooling fan.
- 11 Start the engine and do a function check.

Lubrication System



P0002089

Volvo Penta only recommends the use of genuine Volvo Penta oils with the correct VDS (Volvo Drain Specification) standards.

Genuine Volvo Penta oils are extensively tested and quality assured by Volvo Penta to optimize performance, reduce fuel consumption and maximize the life of the engine.

More detailed information regarding oil quality, viscosity and oil drain interval, refer to chapter Technical Data: *Lubrication System*.

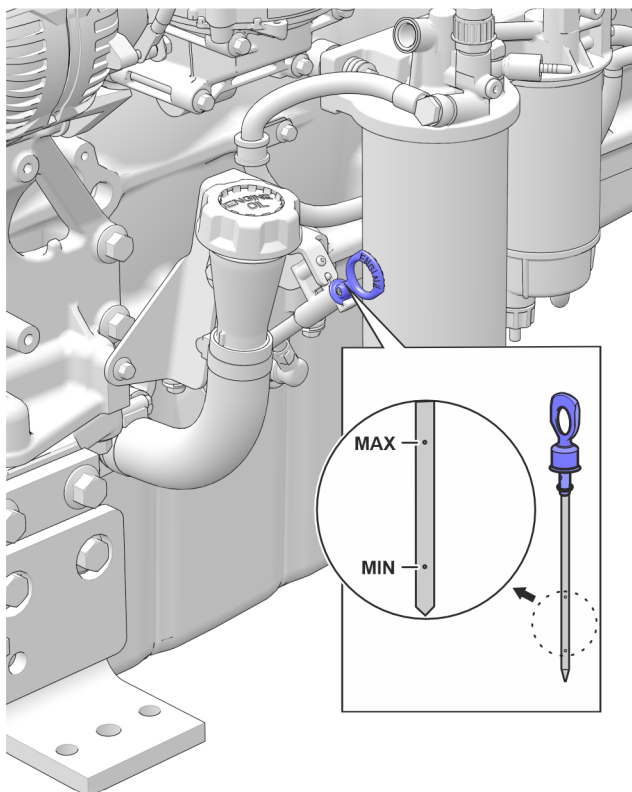

P0039034

Oil level, checking and topping up

⚠ WARNING!

Working with or approaching a running engine is a safety risk. Watch out for rotating components and hot surfaces.

- The engine should be placed on a level position when the oil is checked.
- The oil level is to be checked when the engine is stopped. Wait a few minutes before reading off the level, so that the oil has time to run down into the oil sump.
- The oil level must be inside the marked area on the dipstick. Never fill above the maximum limit on the oil dipstick.
- Only fill oil when the engine is stopped.
- Only use Volvo Penta recommended oils; refer to , page 90.
- The oil level sensor only measures the oil level when the ignition is switched to on, not continuously during operation.

Checking the oil with a flexible dipstick

IMPORTANT:

Insert the dipstick in increments of around 200 mm, without bending the wire, for the entire length of the plastic tube.

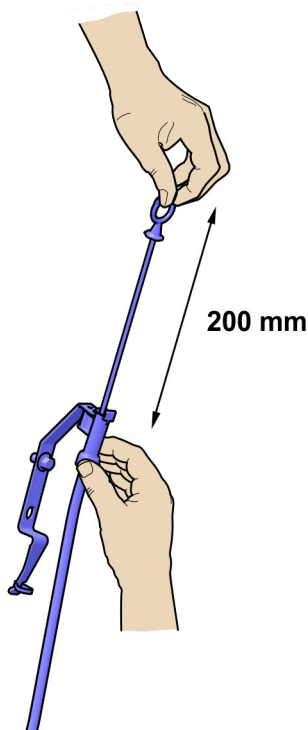

P0026405

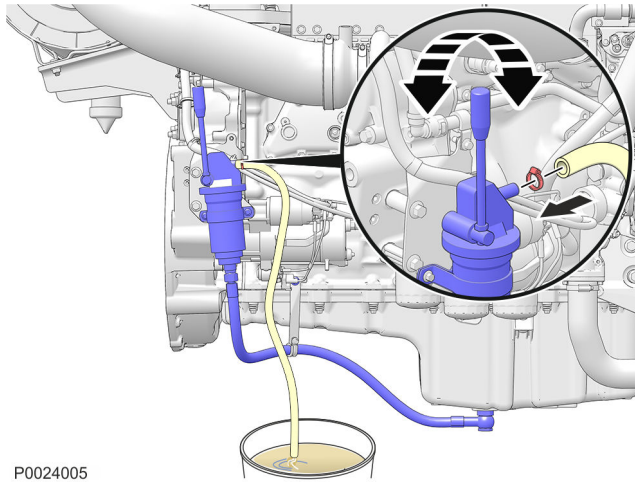

Engine Oil, Replace

⚠ WARNING!

Hot oil and hot surfaces can cause burns.

Oil changes must be done when the engine is hot.

- 1 Connect the drain hose to the oil drain pump and check that no leakage can occur.
- 2 Pump the oil out (or remove the bottom drain plug and drain the oil).
Collect all the old oil and old filters, and hand them to a re-cycling station for destruction.
- 3 Remove the drain hose (or install the bottom drain plug).
- 4 Fill with engine oil.
For change volume, please refer to , *page 90*.

Oil Filter/By-pass Filter, Replace

⚠ WARNING!

Hot oil and hot surfaces can cause burns.

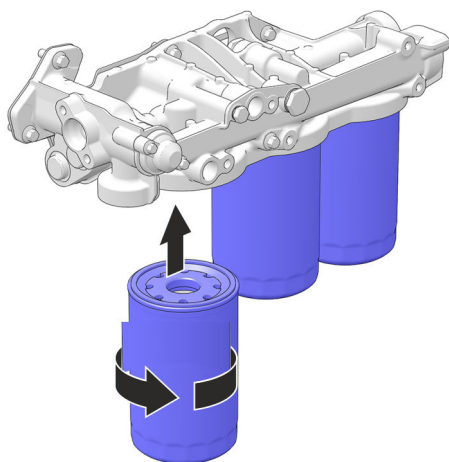
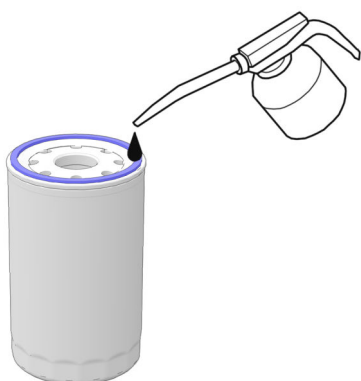
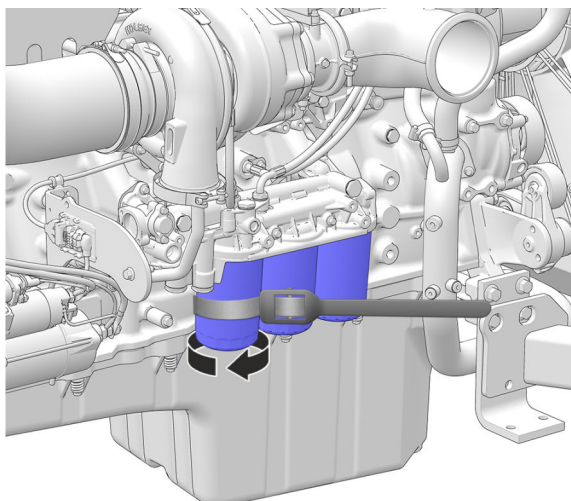

P0025685

- 1 Clean the oil filter bracket (2).
- 2 Remove all oil filters with a suitable oil filter extractor (1).
- 3 Clean the mating surface of the oil filter bracket. Make sure that no pieces of old oil seal are left behind. Carefully clean round the inside of the protective rim (2) on the oil filter bracket.
- 4 Put a thin layer of engine oil on the seal rings of the new fuel filters.
- 5 Install the new oil filters. Tighten the filters $\frac{3}{4}$ –1 turn after they touch.
- 6 Top up with engine oil, start the engine and let it run for 20-30 seconds.
- 7 Turn off the engine, check the oil level and top up as required.
- 8 Check sealing round the oil filters.

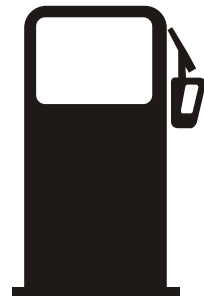

P0002101

Fuel System

⚠ WARNING!

Fire hazard. When carrying out work on the fuel system make sure the engine is cold. A fuel spill onto a hot surface or an electrical component can cause a fire. Store fuel soaked rags so that they cannot cause fire.

IMPORTANT:

Always observe the greatest cleanliness during refueling and work on the fuel system. Only use the grades of fuel recommended in the fuel specification.

Draining condensate, fuel system

NOTICE! Put a collection vessel under the fuel filter to collect the condensate and fuel.

- 1 Open the drain nipple in the base of the fuel pre-filter.
- 2 Tighten the drain tap when fuel without water starts to run out.

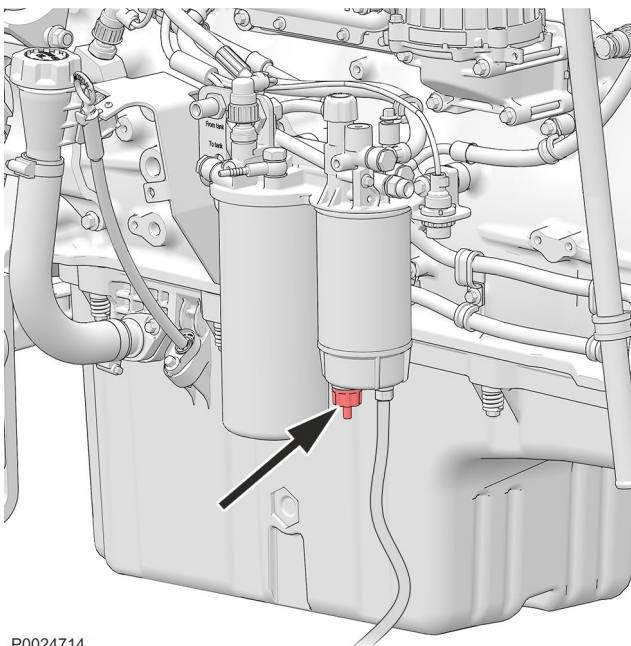

P0024714

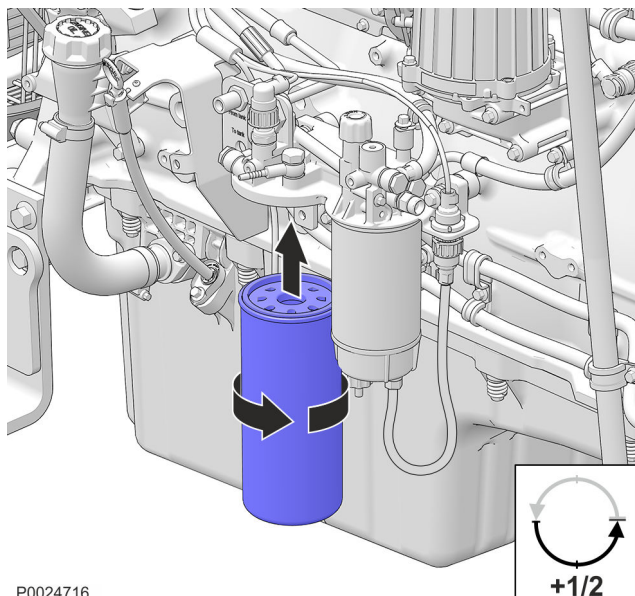

P0024716

Engine Fuel Filter Replacement

⚠ WARNING!

Fire hazard. When carrying out work on the fuel system make sure the engine is cold. A fuel spill onto a hot surface or an electrical component can cause a fire. Store fuel soaked rags so that they cannot cause fire.

IMPORTANT:

Do not fill the new fuel filter with fuel before assembly. There is a risk that contamination could get into the system and cause malfunctions or damage.

- 1 Clean round the fuel filter.
- 2 Remove the filter with a suitable filter remover. Collect any spilled fuel in a collection vessel.
- 3 Clean the filter mating surface on the filter bracket.
- 4 Lubricate the seal with diesel fuel and install the new fuel filter. Tighten the fuel filter in accordance with the instructions on the fuel filter.
- 5 If necessary, vent the fuel system, please refer to *Fuel system, bleeding, page 75*.

Fuel Pre-filter, Replace

- 1 Undo the cable from the water trap sensor.
- 2 Remove the water trap filter from the filter housing. Collect any spilled fuel in a container.
- 3 Remove the lower part of the water trap from the filter.
- 4 Clean the lower part of the water trap with a soft rag. Check that the drain hole in the lower part is not blocked.
- 5 Install a new seal on the lower part and lubricate the seal with diesel fuel. Re-install the lower part of the filter.
- 6 Lubricate the seal with diesel fuel. Screw the filter onto the filter bracket by hand until the rubber seal just touches the mating surface. Then tighten a further half turn, no more.
- 7 Connect the cable to the water trap sensor.
- 8 If necessary, vent the fuel system, please refer to *Bleeding the Fuel System*.

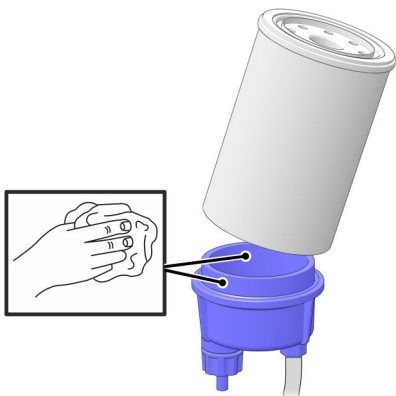
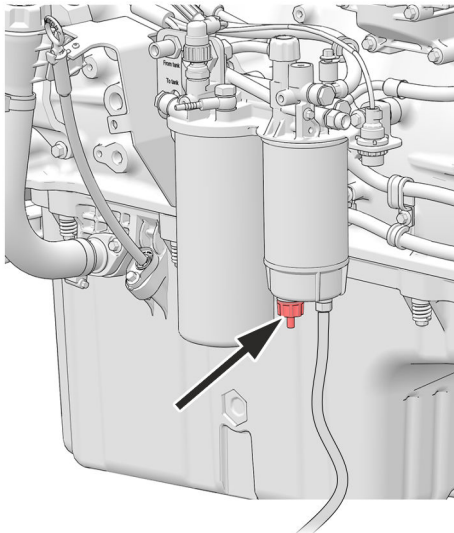
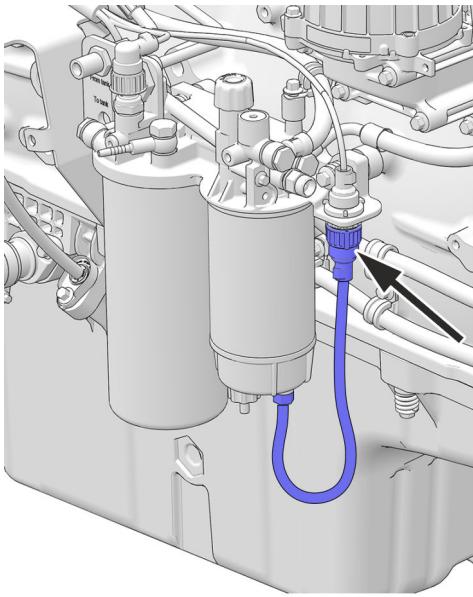

P0025686

Fuel system, bleeding

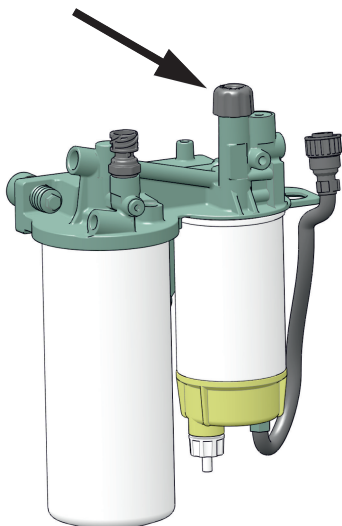

P0025497

- 1 Check that there is sufficient fuel in the tank, and that any fuel taps are open.
- 2 Release the hand pump on the fuel bracket by pushing down and twisting the plastic handle.
- 3 Vent the fuel system by pumping with the hand pump.
Air is vented to the tank via the fuel return pipe. No breathing nipples need be opened.
- 4 Lock the hand pump, push down and twist the handle.
- 5 Start the engine and allow it to idle fast for about 10 minutes.
- 6 Perform a leakage and function check.



P0038119

Cooling System

The cooling system ensures that the engine operates at the correct temperature. It is a closed system that should always be filled with a coolant mixture.

IMPORTANT:

Coolant of a suitable chemical composition must be used all year round to protect the engine against internal corrosion, cavitation and freeze bursting. This even applies when there is no risk for freeze damage, to make sure the engine always has a complete corrosion protection.

Therefore, the use of anti-corrosion agents alone, or water alone as a coolant, is not permitted in Volvo Penta engines.

The coolant must be based on Organic Acid Technology (OAT). Using an improper coolant or mixing with another coolant will rapidly reduce the performance and lifetime of the engine. Material incompatibility can lead to leakages, which - in the worst case - can cause engine breakdown.

Volvo Penta strongly recommend the use of our own coolants, "Volvo Penta Coolant VCS-2 Ready Mixed" or the concentrate "Volvo Penta Coolant VCS-2", which ensure the protection of the cooling system components from corrosion, ageing, swelling and cracking, thereby ensuring optimal engine lifetime.

Over time the corrosion protection additives become less effective, and consequently the coolant must be changed at regular intervals to maintain sufficient protection of the engine. The latest Service Protocol that specifies service intervals can be found at volvopenta.com.

Coolant, Mixing

It is extremely important that the system is filled with the correct coolant concentration; refer to *Coolant, Mixing, page 94*.

The coolant should be mixed with distilled, deionized water. For Volvo Penta specified water requirements; refer to *Coolant, Mixing, page 94*.

NOTICE! If water quality can not be guaranteed, use ready mixed coolant.

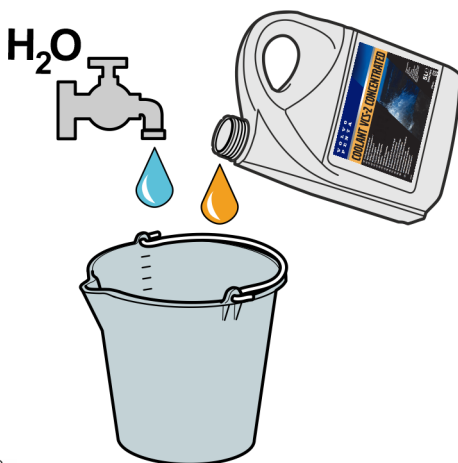

P0038120

Coolant Level, Checking and Topping Up

⚠ WARNING!

Do not open the coolant filler cap when the engine is hot, except in emergencies, as this could cause serious personal injury. Steam or hot fluid could spray out.

IMPORTANT!

Only use coolant recommended by Volvo Penta. Fill up with the same type of coolant that is in the system. VCS-2 will be backwards compatible with current VCS and they are mixable without risks.

Filling of coolant must be performed with the engine stopped. Fill up slowly, to allow the air to flow out. Check the coolant level daily before start.

TWD16

- 1 Open the filler caps (1).
- 2 Check that the coolant reaches the MAX mark on the sight glass (2). Top up with coolant as required.
- 3 Close the filler caps.

TAD16

- 1 Open **only** the filler cap (1). Do not open the pressure cap (2).
- 2 Check that the coolant level is between the MIN and MAX marks on the expansion tank (1). Top up with coolant as required.
- 3 Close the filler cap.

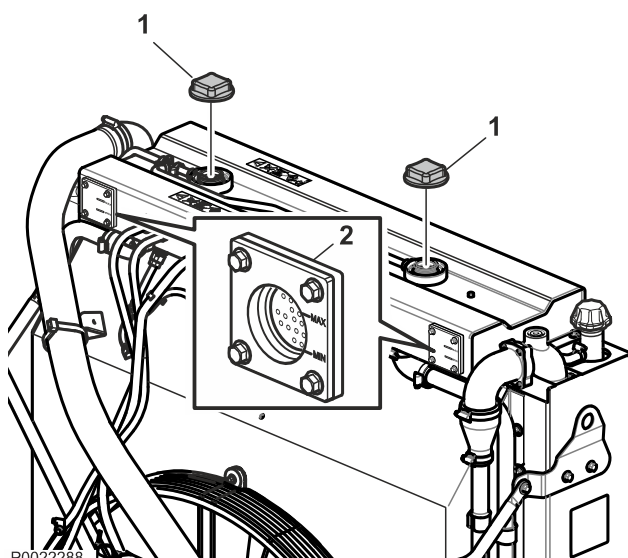

P0022288

TWD16

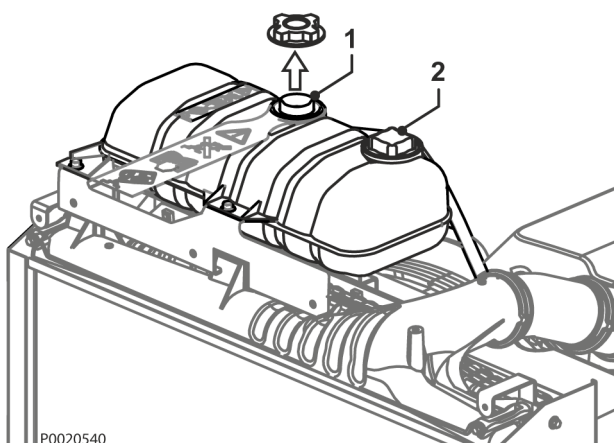

P0020540

TAD16

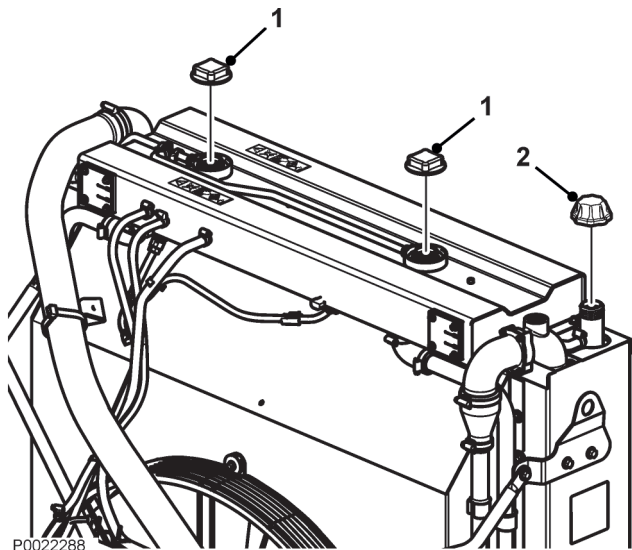

P0022288
TWD16

Filling a completely empty system

NOTICE! Mix the correct amount of coolant in advance, to ensure that the cooling system is completely filled. Refer to , page 93 for the correct coolant volume.

Do not start the engine until the cooling system is completely filled and vented.

NOTICE! If a heating unit is connected to the engine cooling system, the heating control valve should be opened and the installation vented during filling.

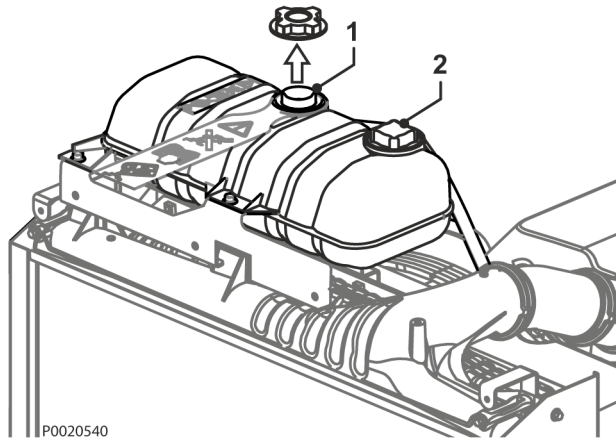

P0020540

TAD16

1 Check that all drain points are closed.

2 **TWD16**

Open the caps to both the expansion tank (1) and the radiator (2). Fill the expansion tank so that the coolant reaches the MAX mark on the sight glass. Close the filler caps.

TAD16

Open **only** the filler cap (1). Fill the expansion tank so that the coolant level is between the MIN and MAX marks. Close the filler cap.

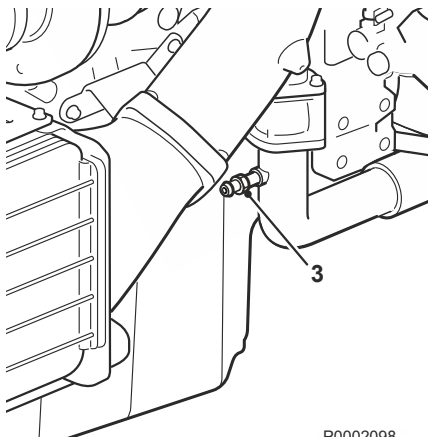

P0002098

3 Bleed the system at the bleeding nipple (3).

4 Start the engine when the coolant system is completely filled and vented.

Open any bleeding nipples a short while after starting, to allow trapped air to escape.

5 Start the engine after approx. one hour and check the coolant level. Top up with coolant as required.

Coolant, Draining

⚠ WARNING!

Do not open the coolant filler cap when the engine is hot, except in emergencies, as this could cause serious personal injury. Steam or hot fluid could spray out.

IMPORTANT!

On engines which are to be put in storage, the engine cooling system should **not** be drained. The coolant contains corrosion inhibiting additives.

- 1 Stop the engine before draining.
- 2 **TWD16**
Open both the pressure caps on the expansion tank (1) and the filler cap to the radiator (2).
TAD16
Open the filler cap (1). Do not remove the pressure cap (2).
- 3 Open all drain points. Drain the coolant from the radiator and engine block, using the drain hose. The drain nipples are situated under the radiator on the right side of the engine block.
- 4 Check that all coolant drains out. Deposits may be found inside the drain plug/tap, and need to be cleared away. There is otherwise a risk that the coolant could remain and cause frost damage. Check whether the installation has any further taps or plugs at the lowest points of the cooling water pipes.
- 5 Close any taps and check that the spring-loaded covers on the nipples close completely. Install the rubber plugs and the filler cap(s).

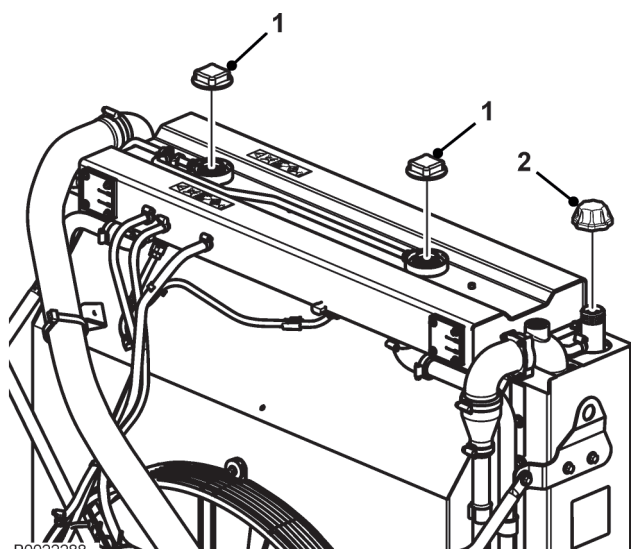

P0022288

TWD16

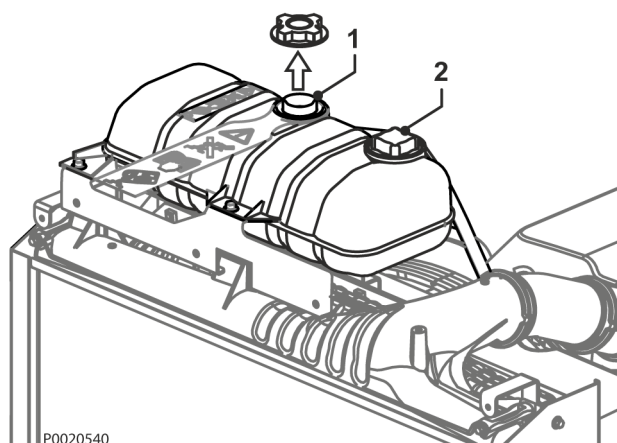

P0020540

TAD16

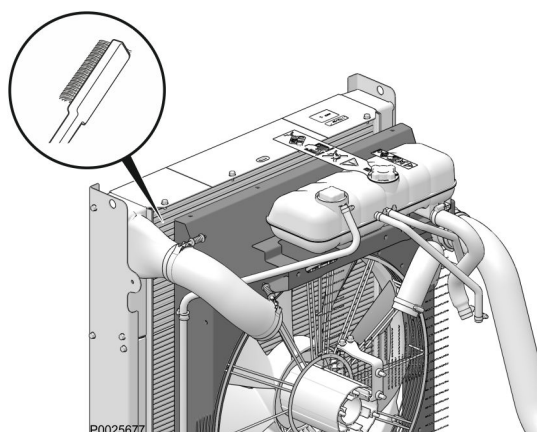

P0025677

Charge Air Cooler, External Cleaning

IMPORTANT:

Do not use a high pressure power washer.

Remove guards as necessary, to access the radiator. Clean with water and a mild detergent. Use a soft brush. Be careful not to damage the radiator vanes. Reinstall removed parts.

Cooling System, Cleaning

⚠ WARNING!

All coolant is hazardous and harmful to the environment. Do not consume. Coolant is flammable.

IMPORTANT:

Never clean the cooling system if there is any risk of freezing, since the cleaning solution does not have any antifreeze properties.

IMPORTANT:

It is extremely important that the correct concentration and volume of coolant is added to the system. Mix in a separate clean vessel before filling the cooling system. Make sure that the liquids mix properly.

IMPORTANT:

Always follow local safety instructions and regulations.

Cooling performance is reduced by deposits in the radiator and cooling galleries. The cooling system should be cleaned out when the coolant is changed.

- 1 Empty the cooling system. Refer to *Coolant, Draining, page 79*.
- 2 Put a hose into the expansion tank filling hole and flush with clean water, as specified by Volvo Penta—refer to section *Water quality in , page 93* until the water draining out is completely clear.
- 3 If there should still be some contamination left after flushing for a long time, cleaning can be done with coolant. Otherwise, continue as in item 8 below.
- 4 Fill the cooling system with 15-20 % mixture of concentrated coolant. Use only Volvo Penta recommended concentrated coolant mixed with clean water.
- 5 Drain the coolant after 1-2 days of operation. Remove the filler cap and possibly the lower radiator hose to increase the speed of emptying. To prevent suspended material from settling back in the system emptying should be done rapidly, within the space of 10 minutes, when the engine has not been standing still for a long time.
- 6 Flush the system immediately and thoroughly with clean hot water to prevent dirt from settling in the inner areas. Flush until the water that runs out is completely clean. Make sure that any heater controls are set to full heating during emptying.

- 7 If contamination should still be left after a long period of flushing, cleanout using Volvo Penta radiator cleaner, followed by finishing-off with Volvo Penta neutralizer. Carefully follow the instructions on the package. Otherwise, continue as in item 8 below.
- 8 When the cooling system is completely free from contamination, close the drain taps and plugs.
- 9 Fill up with Volvo Penta recommended coolant, following the instructions in the chapters entitled , *page 76* and *Coolant Level, Checking and Topping Up, page 77*.

Cooling air filter

⚠ WARNING!

Stop the engine before doing any maintenance work.

A newly-installed cooling air filter reduces cooling performance by 4 %.

Installation

- 1 Slide one half of the filter over the fan cover (as in fig.1).
- 2 Turn the half filter until it is able to hang loosely on the fan cover (see fig. 2).
- 3 Slide on the other filter half and secure the two halves together with self-affixing velcro tape (as in fig. 3a).
- 4 Fasten the outer velcro tape around the fan cover guard (as in fig. 3b and 3c).

Removal and cleaning

- 1 Remove the cooling filter.
- 2 Brush away any heavy dirt with a soft brush.
- 3 Rinse the filter with water.

NOTICE! If a cleaning agent is necessary, an eco-friendly degreaser (e.g. coconut oil based) must be used as a first choice. Alternatively, use a paraffin fraction as a second choice.

Spray on the degreaser or apply it using a sponge. Allow it to act for a few minutes and then rinse with tap water.

IMPORTANT:

Do not use gasoline, steam, a high-pressure washer or other cleaning agents.

- 4 Re-install the filter according to instructions.

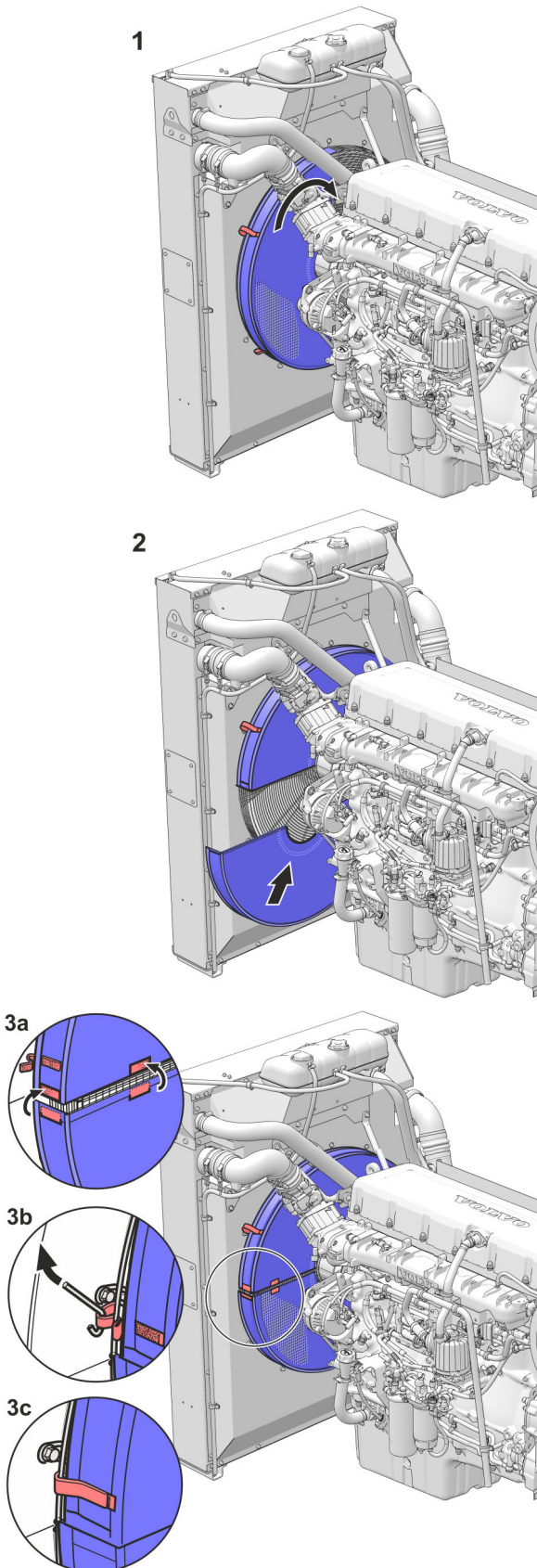

P0025788

Electrical System

The engine is equipped with a 2-pole electrical system and an alternator.

⚠ WARNING!

Always stop the engine and break the current using the main switches before working on the engine.

IMPORTANT:

Contact a Volvo Penta dealer for information if any arc welding will be performed on the application. Arc welding can cause damage to the engine and the electronics.

Main switch

IMPORTANT:

Never disconnect the current using the main switches when the engine is running or by disconnecting the battery cables.

The alternator and electronics could be damaged.

The main switches must never be switched off before the engine has stopped. If the circuit between the alternator and the battery is disconnected when the engine is running, the alternator and electronics may be damaged. For the same reason, the charging circuits must never be re-connected with the engine running.

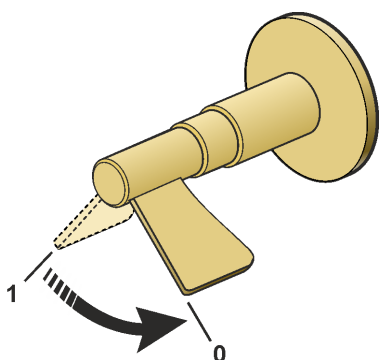

P0002576

Fuses

The engine is equipped with a 10 A circuit breaker which cuts the current if overloaded.

The circuit breaker is located on the left-hand side (cold side) of the engine.

The engine stops if the fuse trips. If the circuit breaker trips frequently, an authorized Volvo Penta workshop should be contacted to investigate the cause of the overload.

Electrical Connections

Check that electrical connections are dry, free from oxide, and that they are securely tightened.



P0002107

Battery

⚠ WARNING!

Risk of fire and explosion. Never allow an open flame or electric sparks near the batteries.

⚠ WARNING!

Battery electrolyte is a corrosive acid and should be handled with care. If you spill or splash electrolyte on any part of the body, immediately flush the exposed area with liberal amounts of water and seek medical attention as soon as possible.

⚠ WARNING!

Ventilate the engine compartment before working on batteries or battery connections.

IMPORTANT:

Batteries can be damaged if they are left discharged, and can also freeze and burst easier in cold weather. If the engine is not going to be used for a longer period of time, the batteries should be fully charged, trickle charged if possible.

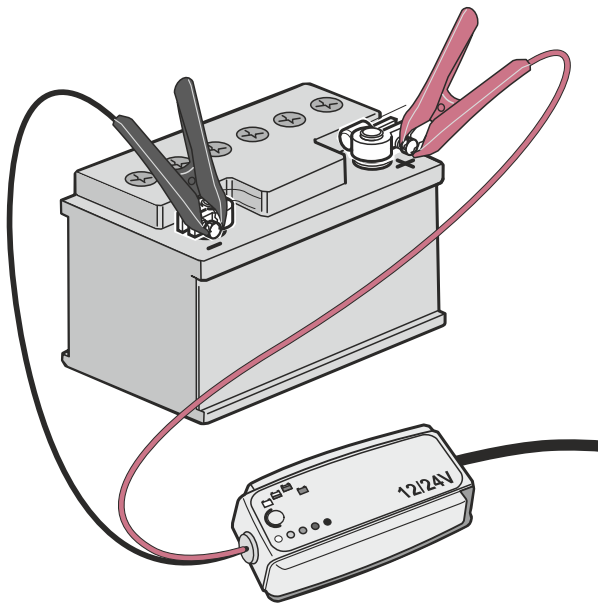

P0022892

Maintenance

It is important to always follow the battery manufacturer's recommendation and instruction when replacing and charging batteries. Depending on battery type, the instructions for maintenance and charging may vary.

Modern batteries are normally maintenance free, but there are some actions that are recommended to increase the battery service life and avoid accidents:

- Keep the batteries clean and dry. Contamination and oxide on the batteries and battery poles can result in stray currents, voltage drop and discharge, especially in wet weather.
- Remove oxidation from the battery poles and terminals, using a brass brush.
- Tighten the terminals securely and grease them with terminal grease or petroleum jelly. Loose battery connections may cause damage to the engine's electrical system.
- Charge the battery regularly. A battery that is kept fully loaded has a maximum service life. The easiest way to check if a battery needs charging is to use a voltmeter.

NOTICE! If low starter battery alarm occur, the battery may get drained which might result in loss of functions and engine stopping.

Replacing Battery

IMPORTANT:

Make sure that the new battery fulfills the specifications in *Technical Data*. Read the information supplied with the battery before you begin the installation.

IMPORTANT:

Do not disconnect the batteries with the engine running.

Sensitive electrical components can be immediately damaged.

⚠ WARNING!

Never confuse the positive and negative poles on the batteries. Risk of arcing and explosion.

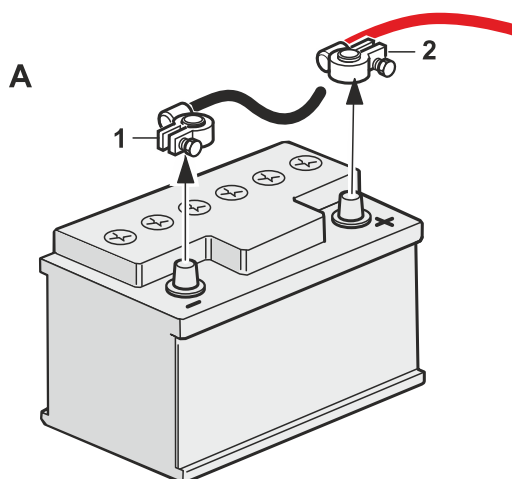

Disconnecting (A)

- 1 Untighten the nut and remove the – cable (black).
- 2 Untighten the nut and remove the + cable (red).

Remove the battery.

Connecting (B)

Place the new battery.

- 1 Connect the + cable (red) to the + pole on the battery and tighten the nut.
- 2 Connect the – cable (black) to the – pole on the battery and tighten the nut.

NOTICE! Hand in the old battery to a re-cycling station.

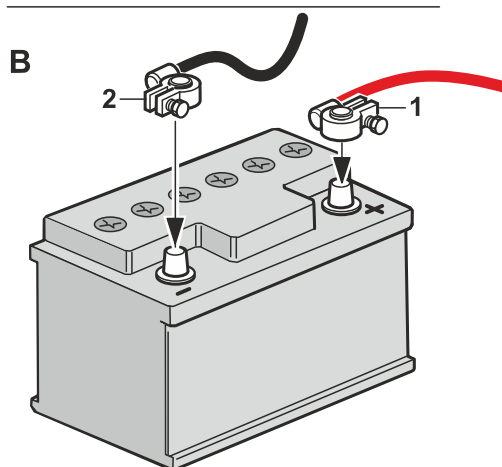

P0022893

Storage

To prevent the engine and other equipment from being harmed during long (2 months or more) periods out of service, it must be conserved. Conservation protects the engine from freezing and corrosion damages.

It is of utmost importance that the conservation is performed correctly, therefore we have compiled a checklist covering the most important points. Before taking the engine out of service for long periods, Volvo Penta recommends that the engine is checked by a qualified workshop for possible need for overhaul or repair.

⚠ CAUTION!

Read the chapter on Maintenance in the Operator's Manual before starting work. It contains instructions on how to carry out maintenance and service operations in a safe and technical correct manner.

⚠ WARNING!

Conservation oils can be flammable and dangerous to inhale. Ensure good ventilation. Use a protective face mask when spraying.

IMPORTANT:

Washing with a power washer: Never aim the water jet at radiators, charge air cooler, seals, rubber hoses or electrical components.



P0002089

- **For up to 8 month's stoppage:**
Change the oil and oil filter on the engine, then run the engine until warm.
- **More than 8 month's stoppage:**
Conserve the lubrication and fuel systems with conservation oil. Refer to the section *Conservation of the lubrication and fuel systems for more than 8 months' stoppage*.
- Make sure the coolant has adequate antifreeze properties. Top up as necessary. Alternatively, you can drain the coolant (also drain the coolant filter).
- Drain any water and contamination from the fuel filters and fuel tank. Fill the fuel tank completely, to avoid condensation.
- Disconnect the battery cables, clean and charge the batteries. Trickle charge the batteries while the equipment is in storage. **A poorly charged battery can freeze and burst.**
- Clean the outside of the engine. Do not use a high pressure washer for engine cleaning. Touch up paint damage with Volvo Penta original paint.
- Put a note on the engine with the date, type of conservation and the conservation oil used.
- Cover the air filter, exhaust pipe and engine if necessary.
- Empty the AdBlue/DEF tank and rinse it with distilled water.

Bringing Out of Storage

- Remove any covers from the engine, air filter and exhaust pipe.
- Fill the engine with the correct quality and viscosity oil into the engine, as necessary, refer to *Technical Data, Lubrication System*. Install a new oil filter if the filter was not changed during conservation.
- Install new fuel filters and bleed the fuel system.
- Check the drive belt(s).
- Check the condition of all rubber hoses, and retighten the hose clamps.
- Close the drain taps and install any drain plugs.
- Check the coolant level. Top up as necessary.
- Connect the fully charged batteries.
- Start the engine and warm it up at fast idle with no load.
- Check that no oil, fuel or coolant leakage occurs.
- Fill the AdBlue/DEF tank. The solution must fulfill ISO 22241 standards.

Conservation of the lubrication and fuel systems for more than 8 months' stoppage:

- Drain the engine oil and fill up with **conservation oil*** to just over the MIN marking on the dipstick.
- Connect the fuel suction and return hoses to a 1/3 full jerrican containing **conservation oil*** and 2/3 diesel fuel.
- Bleed the fuel system.
- Start the engine and run at a fast idle until about 2 liters (0.6 US gal) of the fluid in the jerrican have been used. Stop the engine and re-connect the fuel suction and return lines.
- Drain the conservation oil from the engine.
- Follow the other instructions on the previous page.

* Conservation oils are sold by oil companies.

Technical Data

Engines

Type designation	TAD1641GE-B	TAD1642GE-B	TWD1643GE
Power	Refer to the sales literature		
Torque	Refer to the sales literature		
No. of cylinders	6	6	6
Bore, mm (inch)	144 (5.67)	144 (5.67)	144 (5.67)
Stroke, mm (inch)	165 (6.50)	165 (6.50)	165 (6.50)
Displacement, liter (inch ³)	16.12 (983.9)	16.12 (983.9)	16.12 (983.9)
Weight, dry, kg (lb)	1480 (3263)	1480 (3263)	1700 (3748)
Weight, wet, kg (lb)	1550 (3417)	1550 (3417)	1770 (3902)
Firing order	1-5-3-6-2-4	1-5-3-6-2-4	1-5-3-6-2-4
Compression ratio	16.5:1	16.5:1	16.5:1
Low idle, r/min.	900	900	900

Type designation	TWD1644GE	TWD1645GE
Power	Refer to the sales literature	
Torque	Refer to the sales literature	
No. of cylinders	6	6
Bore, mm (inch)	144 (5.67)	144 (5.67)
Stroke, mm (inch)	165 (6.50)	165 (6.50)
Displacement, liter (inch ³)	16.12 (983.9)	16.12 (983.9)
Weight, dry, kg (lb)	1700 (3748)	1700 (3748)
Weight, wet, kg (lb)	1770 (3902)	1770 (3902)
Firing order	1-5-3-6-2-4	1-5-3-6-2-4
Compression ratio	16.8:1	16.8:1
Low idle, r/min.	900	900

Type designation	TAD1650GE	TAD1651GE	TWD1652GE	TWD1653GE
Power	Refer to the sales literature			
Torque	Refer to the sales literature			
No. of cylinders	6	6	6	6
Bore mm (inch)	144 (5.67)	144 (5.67)	144 (5.67)	144 (5.67)
Stroke mm (inch)	165 (6.50)	165 (6.50)	165 (6.50)	165 (6.50)
Displacement liter (inch ³)	16.12 (983.9)	16.12 (983.9)	16.12 (983.9)	16.12 (983.9)
Weight, dry kg (lb)	1550 (3417)	1550 (3417)	1755 (3869)	1755 (3869)
Weight, wet kg (lb)	1751 (3860)	1751 (3860)	2065 (4553)	2065 (4553)
Firing order	1-5-3-6-2-4	1-5-3-6-2-4	1-5-3-6-2-4	1-5-3-6-2-4
Compression ratio	16.5:1	16.5:1	16.5:1	16.5:1
Low idle, r/min.	900	900	900	900

Type designation	TAD1640VE-C	TAD1641VE-C	TAD1642VE-C	TAD1643VE
Power	Refer to the sales literature			
Torque	Refer to the sales literature			
No. of cylinders	6	6	6	6
Bore mm (inch)	144 (5.67)	144 (5.67)	144 (5.67)	144 (5.67)
Stroke mm (inch)	165 (6.50)	165 (6.50)	165 (6.50)	165 (6.50)
Displacement liter (inch ³)	16.12 (983.9)	16.12 (983.9)	16.12 (983.9)	16.12 (983.9)
Weight, dry kg (lb)	—	—	—	1440 (3175)
Weight, wet kg (lb)	1440 (3175)	1440 (3175)	1440 (3175)	1510 (3329)
Firing order	1-5-3-6-2-4	1-5-3-6-2-4	1-5-3-6-2-4	1-5-3-6-2-4
Compression ratio	16.8:1	16.8:1	16.8:1	17.5:1
Low idle, r/min.	600	600	600	600–900

Type designation	TAD1643VE-B	TAD1650VE	TAD1650VE-B,	TAD1651VE
Power	Refer to the sales literature			
Torque	Refer to the sales literature			
No. of cylinders	6	6	6	6
Bore mm (inch)	144 (5.67)	144 (5.67)	144 (5.67)	144 (5.67)
Stroke mm (inch)	165 (6.50)	165 (6.50)	165 (6.50)	165 (6.50)
Displacement liter (inch ³)	16.12 (983.9)	16.12 (983.9)	16.12 (983.9)	16.12 (983.9)
Weight, dry kg (lb)	—	1425 (3142)	—	—
Weight, wet kg (lb)	1440 (3175)	—	1395 (3075)	1395 (3075)
Firing order	1-5-3-6-2-4	1-5-3-6-2-4	1-5-3-6-2-4	1-5-3-6-2-4
Compression ratio	17.0:1	18.0:1	17.0:1	17.0:1
Low idle, r/min.	600–900	600–900	600–900	600–900

Lubrication System

Oil change volume, including filter change	
Plastic sump (Standard)	48 liters (12.68 US gal)
Aluminum sump (Optional)	55 liters (14.53 US gal)
TAD1643VE-B, TAD1650/51VE: Aluminum sump (Optional)	46 liters (12.15 US gal)
Additional volume: Remote oil filters (Optional)	3 liters (0.80 US gal)
Oil pressure, hot engine	
at rated speed	300-650 kPa (44–94 psi)
Oil filter	
Full flow filter	2
By-pass filter	1
Lube oil pump	
Type	Gear driven

Oil recommendations

Type designation	Oil quality	Oil change interval, reached first in operation:
TAD1641GE-B, TAD1642GE-B, TWD1643GE, TWD1644GE, TWD1645GE, TAD1650GE, TAD1651GE, TWD1652GE, TWD1653GE TAD1640-42VE-C, TAD1643VE, TAD1650VE	VDS-3 VDS-4 VDS-4.5	600 hours or 12 months
TAD1650VE-B, TAD1651VE TAD1643VE-B	VDS-3 VDS-4 VDS-4.5	500 hours or 12 months

NOTICE! Lube oil change intervals shall be halved, when Bio fuel B11-30 applied.

VDS = Volvo Drain Specification

Viscosity

Select the viscosity according to the table.

The temperature values refer to stable ambient temperatures.

NOTICE! Volvo Penta recommendation for lowest possible fuel consumption and optimal durability is to use SAE 10W-30 oil when the viscosity table allows.

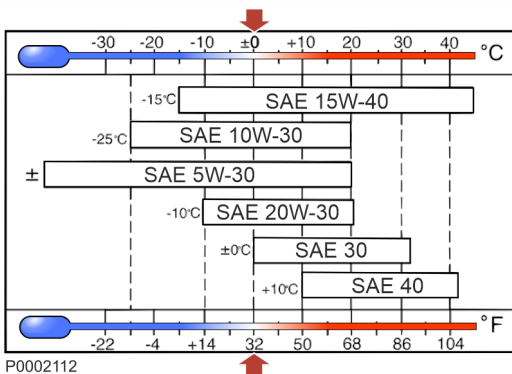

Fuel System

Feed pump	
Feed pressure at 900 rpm	min 100 kPa (14.5 psi)
Feed pressure at 1800 rpm	min 300 kPa (43,5 psi)
Feed pressure at full load	min 300 kPa (43,5 psi)
Bypass valve	
Opening pressure	400-550 kPa (58–80 psi)

General requirements

Volvo Penta diesel engines are certified for compliance with emission legislations with the diesel test fuels specified by law. These fuels correspond with diesel fuel standards EN 590, ASTM D975, JIS K2204 and paraffinic diesel fuel standard EN 15940. However, the usage of other fuels, may have a negative impact on emissions and expected lifetime of the engine.

It is the responsibility of the fuel suppliers to always ensure that their fuels meet relevant requirements and are fit for their intended purpose. Their responsibility includes any use of additives for proper engine performance and function.

Special requirements are placed on cold-flow properties, that is, temperature limit values of fuel filterability during operation in winter conditions.

Restrictions for specified diesel fuels

- **Max density for ASTM D975 No 2-D: 860 kg/m³**
Insufficient density reduces the power and increases the fuel consumption. Excessive density endangers the durability and function of the fuel injection equipment.
- **Max lubricity (wsd 1.4) for JIS K 2204: 460 µm**
Sufficient fuel lubricity is essential to protect the fuel injection system against excessive wear.

Restrictions for other diesel fuels

Volvo Penta also approves the use of other diesel fuels as long as the here specified restrictions are followed. However, the usage of other fuels, may have a negative impact on emissions and expected lifetime of the engine.

NOTICE! Operators must check permission for usage of these fuels according to regional, national or local regulations.

- **Min cetane number: 40**
An insufficient cetane number ("ignitability") leads to poor startability and increased exhaust emissions.
- **Max density at 15 °C: 860 kg/m³**
Insufficient density reduces the power and increases the fuel consumption. Excessive density endangers the durability and function of the fuel injection equipment.
- **Viscosity between 1.9 to 4.6 mm/s² at 40 °C**
Insufficient viscosity reduces the power and increases the fuel consumption. Excessive viscosity endangers the durability and function of the fuel injection equipment.
- **Max lubricity (wsd 1.4): 520 µm**
Sufficient fuel lubricity is essential to protect the fuel injection system against excessive wear.
- **Max FAME (biodiesel) content: 10% (V/V)**
FAME is blended into diesel fuel.
- **Max sulfur content: 5000 mg/kg**

Paraffinic fuels - HVO and GTL

Paraffinic diesel fuels (“Synthetic Diesel”) have higher cetane numbers and lower densities than diesel fuels. HVO (Hydrotreated Vegetable Oils) is renewable paraffinic fuels. GTL (Gas-To-Liquid) is fossil paraffinic fuels.

Volvo Penta approves the use of paraffinic diesel fuels that complies with standard EN 15940. The fuel guarantees compliance with emission legislation and fulfills the expected lifetime as long as the service requirements are followed.

Volvo Penta also approves the use of fuel blends between these paraffinic fuels and diesel fuels that comply with the quality requirements.

Biodiesel fuels

Alternative fuels, including biodiesel, that are not substantially similar to the required test fuels may adversely affect engine emissions compliance. As a result, Volvo Penta does not warrant the engine will conform to applicable emissions limits when operated on, or having been operated on, biodiesel or other alternative fuels that are not substantially similar to specified test fuels used for certification.

The use of biodiesel up to maximum 10% (B10) in and of itself, will not affect the manufacturers mechanical warranty, provided the biodiesel used in blend conforms to EN590, EN16734, ASTM D975 and ASTM D7467. Other relevant local fuel standards that fulfill the above mentioned standards may also be used. A minor drop in engine power will occur when using biodiesel.

NOTICE! Biodiesel manufactured by FAME (Fatty Acid Methyl Esther) process is hygroscopic and therefore increase the risk of bacterial growth in the fuel. This may lead to blocked fuel filters. Engine not consuming a full fuel tank within 4 weeks must not use biodiesel.

Higher levels of biodiesel, up to B30, may be used with restrictions. Fuel according to EN 16709 or ASTM D7467, or relevant local fuel standards that fulfill mentioned biodiesel fuel standards, must be used. Volvo Penta does not warrant the engine will conform to applicable emissions limits when operated on biodiesel or another alternative fuels, that are not substantially similar to specified test fuels used for certification.

Service restrictions for diesel fuel with FAME content between 11% and 30% (B11 to B30)

- Oil dilution may occur. Make sure that oil level is not exceeding maximum level, in that case change the oil.
- Lube oil change intervals shall be halved, or utilize oil sampling analysis.
- The engines should be fitted with fuel filters with water separators.
- A fuel heater is required, when high FAME diesel fuels are used below freezing point.
- Biodiesel is aggressive to some materials used in fuel system components. Inspect seals, hoses, rubber and plastic components daily. Replace any component that is damaged, softened or leaking. Clean biodiesel from painted surfaces immediately to prevent paint damage.
- Do not use these fuels for engines with long downtime periods.
- If the engine has not been used for a period of 4 weeks or more, the tank and the fuel system shall be flushed clean by running the engine on at least one full tank of diesel fuel.
- When shifting from diesel fuel to high FAME diesel fuel.
 - The fuel hoses and sealings shall be replaced.
 - The fuel tank shall be cleaned and the fuel filter shall be replaced after 50 h.

Cooling System

Type	Pressurized, sealed
Pressure cap, max opening pressure	75 kPa (10.88 PSI)
Volume (Volvo Penta cooling system)	
TAD1641GE-B, TAD1642GE-B, TAD1650GE, TAD1651GE	
Engine with standard radiator and hoses (Pusher system)	61 liters (16.1 US gal)
Engine with HD radiator and hoses (Pusher system)	56 liters (14.8 US gal)
TAD1643VE TAD1650VE, TAD1651VE TAD1640-42VE-C, TAD1643VE-B, TAD1650VE-B	
Engine with standard radiator and hoses (Pusher system)	61 liters (16.1 US gal)
Engine with standard radiator and hoses (Puller system)	54 liters (14.3 US gal)
Engine with HD radiator and hoses (Pusher and puller system)	56 liters (14.8 US gal)
TWD1643GE, TWD1644GE, TWD1645GE, TWD1652GE, TAD1653GE	
Engine circuit Total coolant volume engine circuit	59.5 liters (15.72 US gal)
Charge air cooler circuit Total coolant volume CAC circuit	30,5 liters (8.06 US gal)
Thermostat	
Qty	1 st
Opening temperature	82 °C (179.6 °F)

TAD1640VE-C, TAD1641VE-C, TAD1642GE-B, TAD1642VE-C, TAD1643VE, TAD1643VE-B, TAD1650GE, TAD1650VE, TAD1650VE-B, TAD1651GE, TAD1651VE, TWD1643GE, TWD1644GE, TWD1645GE, TWD1652GE, TWD1653GE

Coolant, Mixing

⚠ WARNING!

All coolant is hazardous and harmful to the environment. Do not consume. Coolant is flammable.

NOTICE! Always use the same type of coolant that is already in the engine.

VCS-2 will be backwards compatible with current VCS and they are mixable without risks.

Coolant shall be based on Organic Acid Technology (OAT).



P0038119

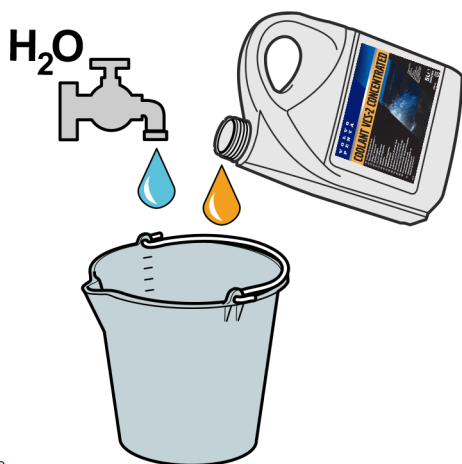

P0038120

Follow the mixing recommendation on the product.

The coolant should be mixed with distilled, deionized water. For Volvo Penta specified water requirements; refer to *Water Quality*, page 94.

NOTICE! Always use “Ready Mixed” coolant if water quality cannot be determined or if it does not fulfill ASTM D4985.

NOTICE! Never mix more than 60% concentrated coolant with water. A greater concentration provides reduced cooling effect with the risk for overheating and reduced freeze protection.

Water Quality

ASTM D4985:

Total solid particles	<340 ppm
Total hardness	<9,5° dH
Chloride	<40 ppm
Sulfate	<100 ppm
pH value	5.5–9
Silica (acc. ASTM D859)	<20 mg SiO ₂ /l
Iron (acc. ASTM D1068)	<0.10 ppm
Manganese (acc. ASTM D858)	<0.05 ppm
Conductivity (acc. ASTM D1125)	<500 µS/cm
Organic content, COD _{Mn} (acc. ISO8467)	<15 mg KMnO ₄ /l



P0002094

Electrical System

System voltage	24V
Alternator	
Voltage/max. amperage	28V/110A
Power	2800W
Alternative generating equipment (optional)	
Voltage/max. amperage	28V/150A
Power	4000W
Battery capacity	2 pcs. series connected 12 V, max. 220 Ah
Battery electrolyte density at +25°C °	
Fully charged battery	1,28 g/cm ³ (1,24 g/cm ³)*
Battery recharged at	1,20 g/cm ³ (1,20 g/cm ³)*

NOTICE! * Applies to batteries with tropical acid.

Electrical platform

EMS 2.0	TAD1643VE, TWD1643GE
EMS 2.2	TAD1650VE TAD1650GE, TAD1651GE TWD1652GE, TWD1653GE
EMS 2.3	TAD1643VE-B TWD1644GE, TWD1645GE TAD1650VE-B TAD1651VE
EMS 2.4	TAD1641GE-B, TAD1642GE-B, TAD1640VE-C, TAD1641VE-C, TAD1642VE-C

Identification Numbers

NOTICE! The engine labels are placed on the valve cover.

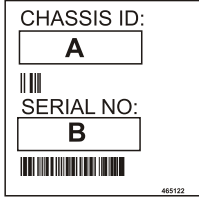

P0002051

- A Chassis ID
- B Serial number

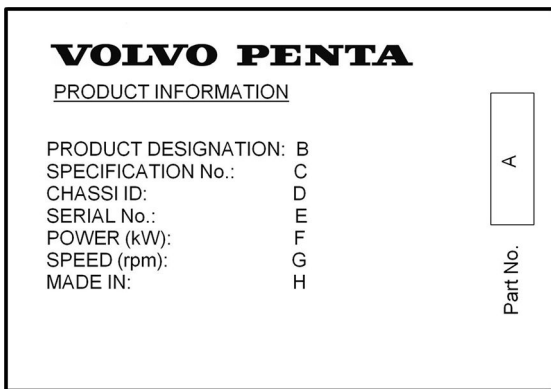

P0024526

- A Label part number
- B Product designation
- C Specification number
- D Chassis ID
- E Serial number
- F Power (kW)
- G Engine speed (rpm)
- H Country of manufacturing

VOLVO PENTA

Declaration of incorporation for the installation of partially completed machinery in accordance with Machinery Directive 2006/42/EC, Annex II, 1B

Engine Manufacturer:

AB Volvo Penta
Gropegårdsgatan 11
SE 405 08 Gothenburg, Sweden

Product designation:

Engine size	Model
5 liter, VE	TAD540VE - TAD541VE - TAD542VE - TAD550VE - TAD551VE - TAD552VE - TAD570VE - TAD571VE - TAD572VE - TAD580VE - TAD581VE - TAD582VE - TAD583VE
8 liter, VE	TAD840VE - TAD841VE - TAD842VE - TAD843VE - TAD850VE - TAD851VE - TAD852VE - TAD853VE - TAD870VE - TAD871VE - TAD872VE - TAD873VE - TAD880VE - TAD881VE - TAD882VE - TAD883VE - TAD884VE
8 liter, GE	TAD840GE - TAD840GE-B - TAD841GE - TAD842GE - TAD843GE - TAD880GE - TAD881GE - TAD882GE - TAD851GE - TAD852GE - TAD853GE
11 liter, VE	TAD1140VE - TAD1141VE - TAD1142VE - TAD1150VE - TAD1151VE - TAD1152VE - TAD1170VE - TAD1171VE - TAD1172VE - TAD1180VE - TAD1181VE - TAD1182VE - TAD1183VE
13 liter, VE	TAD1340VE - TAD1341VE - TAD1342VE - TAD1343VE - TAD1344VE - TAD1345VE - TAD1350VE - TAD1351VE - TAD1352VE - TAD1353VE - TAD1371VE - TAD1372VE - TAD1373VE - TAD1374VE - TAD1375VE - TAD1381VE - TAD1382VE - TAD1383VE - TAD1384VE - TAD1385VE
13 liter, GE	TAD1341GE-B - TAD1342GE-B - TAD1342GE-B - TAD1343GE-B - TAD1344GE-B - TAD1345GE-B - TAD1346GE - TAD1350GE - TAD1351GE - TAD1352GE - TAD1353GE - TAD1354GE - TAD1355GE - TAD1380GE - TAD1381GE - TAD1382GE
16 liter, VE	TAD1640VE-B - TAD1641VE-B - TAD1642VE-B - TAD1640VE-C - TAD1641VE-C - TAD1642VE-C - TAD1643VE - TAD1643VE-B - TAD1650VE-B - TAD1651VE - TAD1670VE - TAD1671VE - TAD1672VE - TWD1683VE
16 liter, GE	TAD1640GE-B - TAD1641GE-B - TAD1642GE-B - TWD1644GE - TWD1645GE - TAD1650GE - TAD1651GE - TWD1652GE - TWD1653GE - TWD1672GE - TWD1673GE - TWD1683GE - TWD1683GE-B
17 liter, GE	TWD1744GE

Description: 4-cycle diesel engine.

Fundamental health and safety requirements applied to, and fulfilled by, the above-mentioned engines are described in the following items in Annex I:

1.1.3, 1.1.5, 1.5.2, 1.5.3, 1.5.4, 1.5.6, 1.5.13, 1.6.1, 1.6.2, 1.7.1, 1.7.4, 1.7.4.1 and 1.7.4.3.

The relevant technical documentation is compiled as described in part B of Annex VII.

It is also in conformity with the relevant union harmonization legislation: EMC 2014/30/EU

The following harmonized standards have been applied:

EN ISO 12100:2010 // EN 1679-1+A1:2011 //

EN IEC 61000-6-1:2019 // EN IEC 61000-6-2:2019 // EN IEC 61000-6-3:2021 //

EN IEC 61000-6-4:2019 //

EN 12895:2015 + A1:2019 // EN-ISO 14982:2009 // EN 13766-1:2018

For engines equipped with Volvo Penta control interface module:

Paragraph 6.4 (Emergency stop) in 1679-1 + A1 2011 is not verified for engines equipped with Volvo Penta Control Interface Module. Responsibility lies with the machine manufacturer to add one or several emergencies stops in accordance with paragraph 1.2.4.3 (2006/42/EC).

For engines equipped with the Volvo Penta Start/Stop System the responsibility for the functional safety of the system lies with the machine manufacturer performing the integration.

Relevant information concerning the partially completed machinery will be provided in suitable form upon justified requests from competent national authorities. The individual authorized to compile the relevant technical documentation is the signer of this declaration.

The engines covered by this declaration may not be put into operation before the completed machinery into which they are to be installed has been declared to conform with the provision of Machinery Directive 2006/42/EC.

Name and function:

Anders B Berle, Director Safety Compliance

(The identity of the individual authorized to sign on behalf of the engine manufacturer or the latter's authorized representative.)

Signature and title:



Date and place of issue: 2024-04-04 Gothenburg

Phoenix no. 50334799

VOLVO PENTA

Declaration of incorporation for the installation of partially completed machinery in accordance with Supply of machinery (Safety) Regulations 2008, placed on the UK-market

Engine Manufacturer:

AB Volvo Penta
Gropegårdsgatan 11
SE 405 08 Gothenburg, Sweden

Product designation:

Engine size	Model
5 liter, VE	TAD540VE - TAD541VE - TAD542VE - TAD550VE - TAD551VE - TAD552VE - TAD570VE - TAD571VE - TAD572VE - TAD580VE - TAD581VE - TAD582VE - TAD583VE
8 liter, VE	TAD840VE - TAD841VE - TAD842VE - TAD843VE - TAD850VE - TAD851VE - TAD852VE - TAD853VE - TAD870VE - TAD871VE - TAD872VE - TAD873VE - TAD880VE - TAD881VE - TAD882VE - TAD883VE - TAD884VE
8 liter, GE	TAD840GE - TAD840GE-B - TAD841GE - TAD842GE - TAD843GE - TAD880GE - TAD881GE - TAD882GE - TAD851GE - TAD852GE - TAD853GE
11 liter, VE	TAD1140VE - TAD1141VE - TAD1142VE - TAD1150VE - TAD1151VE - TAD1152VE - TAD1170VE - TAD1171VE - TAD1172VE - TAD1180VE - TAD1181VE - TAD1182VE - TAD1183VE
13 liter, VE	TAD1340VE - TAD1341VE - TAD1342VE - TAD1343VE - TAD1344VE - TAD1345VE - TAD1350VE - TAD1351VE - TAD1352VE - TAD1353VE - TAD1371VE - TAD1372VE - TAD1373VE - TAD1374VE - TAD1375VE - TAD1381VE - TAD1382VE - TAD1383VE - TAD1384VE - TAD1385VE
13 liter, GE	TAD1341GE-B - TAD1342GE-B - TAD1342GE-B - TAD1343GE-B - TAD1344GE-B - TAD1345GE-B - TAD1346GE - TAD1350GE - TAD1351GE - TAD1352GE - TAD1353GE - TAD1354GE - TAD1355GE - TAD1380GE - TAD1381GE - TAD1382GE
16 liter, VE	TAD1640VE-B - TAD1641VE-B - TAD1642VE-B - TAD1640VE-C - TAD1641VE-C - TAD1642VE-C - TAD1643VE - TAD1643VE-B - TAD1650VE-B - TAD1651VE - TAD1670VE - TAD1671VE - TAD1672VE - TWD1683VE
16 liter, GE	TAD1640GE-B - TAD1641GE-B - TAD1642GE-B - TWD1644GE - TWD1645GE - TAD1650GE - TAD1651GE - TWD1652GE - TWD1653GE - TWD1672GE - TWD1673GE - TWD1683GE - TWD1683GE-B
17 liter, GE	TWD1744GE

Description: 4-cycle diesel engine.

Fundamental health and safety requirements applied to, and fulfilled by, the above-mentioned engines are described in the following items in Annex I:

1.1.3, 1.1.5, 1.5.2, 1.5.3, 1.5.4, 1.5.6, 1.5.13, 1.6.1, 1.6.2, 1.7.1, 1.7.4, 1.7.4.1 and 1.7.4.3.

The relevant technical documentation is compiled as described in part B of Annex VII.

It is also in conformity with the relevant union harmonization legislation: EMC 2014/30/EU

The following harmonized standards have been applied:

EN ISO 12100:2010 // EN 1679-1+A1:2011 //

EN IEC 61000-6-1:2019 // EN IEC 61000-6-2:2019 // EN IEC 61000-6-3:2021 //

EN IEC 61000-6-4:2019 //

EN 12895:2015 + A1:2019 // EN-ISO 14982:2009 // EN 13766-1:2018

For engines equipped with Volvo Penta control interface module:

Paragraph 6.4 (Emergency stop) in 1679-1 + A1 2011 is not verified for engines equipped with Volvo Penta Control Interface Module. Responsibility lies with the machine manufacturer to add one or several emergencies stops in accordance with paragraph 1.2.4.3 (2006/42/EC).

For engines equipped with the Volvo Penta Start/Stop System the responsibility for the functional safety of the system lies with the machine manufacturer performing the integration.

Relevant information concerning the partially completed machinery will be provided in suitable form upon justified requests from competent national authorities. The individual authorized to compile the relevant technical documentation is the signer of this declaration.

The engines covered by this declaration may not be put into operation before the completed machinery into which they are to be installed has been declared to conform with the provision of Machinery Directive 2006/42/EC.

Name and function:

Anders B Berle, Director Safety Compliance

(The identity of the individual authorized to sign on behalf of the engine manufacturer or the latter's authorized representative.)

Signature and title:



Date and place of issue: 2024-04-04 Gothenburg

Phoenix no. 50334795

Index

A		N	
After Engine Shutdown.....	45	Never Use Start Spray.....	39
Air Filter, Check and Replace.....	64	O	
Alarms.....	40	Oil Filter/By-pass Filter, Replace.....	71
Alternator Belt, Replace.....	67	Oil level, checking and topping up.....	69
Auxiliary Stop.....	44	Operation at low load.....	41
B		Orientation.....	59
Battery.....	84	R	
Before Engine Shutdown.....	43	Reading the Instruments.....	40
Before start of engine.....	8	S	
Before Starting.....	36	Starting in Extreme Cold.....	38
Blue light mode.....	17	Starting the Engine.....	37
C		Starting Using Auxiliary Batteries.....	39
Charge Air Cooler, External Cleaning.....	79	Stop the Engine.....	43
Charge Air Pipe, Leakage Check.....	65	V	
CIU (Control Interface Unit).....	34, 49	Viscosity.....	90
Coolant Level, Checking and Topping Up.....	77	Volvo Penta Action Service.....	18
Coolant, Draining.....	79	Volvo Penta Dealer Network.....	18
Cooling air filter.....	82	W	
Cooling System.....	76, 93	Water Quality.....	94
Cooling System, Cleaning.....	80		
D			
DCU (Display Control Unit).....	37		
DCU (Display Control unit).....	46		
DCU II (Display Control Unit).....	47		
Diagnostic Function.....	46		
Display Control Unit.....	21		
Draining condensate, fuel system.....	72		
Drive Belt and Alternator Belt, Inspection.....	65		
Drive Belt, Replace.....	66		
DU (Display Unit).....	31, 48		
E			
Easy Link Instruments.....	35, 49		
Electrical Connections.....	83		
Electrical System.....	83, 95		
EMS (Engine Management System).....	20		
Engine Fuel Filter Replacement.....	73		
Engine Oil, Replace.....	70		
Engine, General.....	64		
Engines.....	19, 88		
Erasing fault codes.....	50		
Excessive strain on a product and components.....	15		
F			
Fault Tracing.....	51		
Fuel Pre-filter, Replace.....	74		
Fuel System.....	72, 91		
Fuel system, bleeding.....	75		
Fuel, oils and coolant.....	13		
I			
Identification Numbers.....	96		
L			
Lubrication System.....	68, 90		
M			
Main switch.....	83		
Maintenance and replacement parts.....	13		
Maneuvering.....	41		



A series of 20 horizontal dotted lines spanning the width of the page, providing a guide for handwriting practice.

ENG

This Operator's Manual may be ordered in a different language free of charge up to 12 months after delivery, via internet.

<http://manual.volvopenta.com/coupon/>

If internet access isn't possible, please contact your Volvo Penta dealer.

GER

Diese Betriebsanleitung kann bis zu 12 Monate nach der Lieferung über Internet kostenlos in einer anderen Sprache bestellt werden.

<http://manual.volvopenta.com/coupon/>

Wenn Sie keinen Internet-Zugriff haben, kontaktieren Sie bitte Ihren Volvo Penta-Händler.

FRE

Ce manuel d'utilisation peut être commandé gratuitement sur Internet en différentes langues, jusqu'à 12 mois après la date de livraison.

<http://manual.volvopenta.com/coupon/>

Veuillez contacter votre Distributeur Volvo Penta si vous avez un problème d'accès à l'Internet.

SPA

El presente libro de instrucciones puede solicitarse en otro idioma diferente, libre de cargo, hasta 12 meses después de la entrega, mediante internet.

<http://manual.volvopenta.com/coupon/>

Si no se tiene acceso a internet, contacten al su concesionario Volvo Penta.

ITA

Il manuale per l'operatore può essere ordinato tramite Internet, in varie lingue e per consegna gratuita, entro 12 mesi dalla consegna del prodotto

<http://manual.volvopenta.com/coupon/>

Se l'accesso a Internet risulta impossibile, contattare la concessionaria Volvo Penta.

SWE

Denna instruktionsbok kan beställas via internet på ett annat språk gratis i upp till 12 månader efter leverans.

<http://manual.volvopenta.com/coupon/>

Kontakta din Volvo Penta-återförsäljare om du inte har tillgång till internet.

DUT

Dit instructieboek kan gratis via internet in een andere taal worden besteld tot 12 maanden na aflevering.

<http://manual.volvopenta.com/coupon/>

Als toegang tot het internet niet mogelijk is, neem dan contact op met uw Volvo Penta dealer.

DAN

Denne instruktionsbog kan bestilles gratis på et andet sprog via Internettet i op til 12 måneder efter leveringen.

<http://manual.volvopenta.com/coupon/>

Hvis det ikke er muligt at bestille via Internettet, bedes du kontakte din Volvo Penta forhandler.

FIN

Tämä käyttöohjekirja on tilattavissa Internetin kautta veloituksetta eri kielillä 12 kuukauden ajan toimituksen jälkeen.

<http://manual.volvopenta.com/coupon/>

Jos sinulla ei ole Internet-yhteyttä, ota yhteys lähimpään Volvo Penta jälleenmyyjään.

POR

Este Manual do Operador pode ser encomendada em idiomas diferentes isento de custos até 12 meses após entrega, via internet.

<http://manual.volvopenta.com/coupon/>

Se não for possível aceder à internet, contacte o seu concessionário Volvo Penta.

GRC

Το παρόν Βιβλίο Χρήσης μπορεί να παραγγελθεί δωρεάν σε άλλη γλώσσα μέχρι 12 μήνες μετά την παράδοση, μέσω διαδικτύου.

<http://manual.volvopenta.com/coupon/>

Εάν δεν είναι δυνατή η πρόσβαση στο ιαδίκτυο, παρακαλούμε επικοινωνήστε με το δικό σας αντιπρόσωπο της Volvo Penta.

TUR

Bu Kullanım Kılavuzu, teslimden 12 ay sonrasına kadar İnternet yoluyla ücretsiz olarak farklı bir dilde sipariş edilebilir.

<http://manual.volvopenta.com/coupon/>

İnternet mümkün değilse, lütfen Volvo Penta yetkili satıcınızla temasa geçin.

CHI

本操作手册可通过互联网以不同的言进行订购，交付后可免费使用达12个月。

<http://manual.volvopenta.com/coupon/>

如果无法访问互联网，请与沃尔沃遍达经销商联系。

BZS

Este Manual de operador pode ser encomendado em um idioma diferente, gratuitamente, até 12 meses após a entrega, via internet.

<http://manual.volvopenta.com/coupon/>

Caso o acesso à internet não for possível, contatar seu distribuidor Volvo Penta.

JPN

このオペレーターズ マニュアルの他言語版が、発行後最高12か月間、インターネットより無料で発注可能です。

<http://manual.volvopenta.com/coupon/>

インターネットにアクセスできない場合は、担当のボルボペンタディーラーまでご連絡ください。

ARA

من الممكن طلب دليل المشغل بلغة أخرى عبر الإنترنت لفترة تصل إلى 12 شهرين بعد التسليم.

[http:// manual.volvopenta.com/coupon](http://manual.volvopenta.com/coupon/)

فإن الوصول إلى الإنترنت غير متاح، فالرجاء الاتصال بوكيل Volvo Penta.

V O L V O P E N T A



