

Installation

Industrial Generator Sets



Models:

10-4000 kW

⚠ WARNING: This product can expose you to chemicals, including carbon monoxide and benzene, which are known to the State of California to cause cancer and birth defects or other reproductive harm. For more information go to www.P65warnings.ca.gov

⚠ WARNING: Breathing diesel engine exhaust exposes you to chemicals known to the State of California to cause cancer and birth defects or other reproductive harm.

- Always start and operate the engine in a well-ventilated area.
- If in an enclosed area, vent the exhaust to the outside.
- Do not modify or tamper with the exhaust system.
- Do not idle the engine except as necessary.

For more information go to www.P65warnings.ca.gov/diesel

Product Identification Information

Product identification numbers determine service parts. Record the product identification numbers in the spaces below immediately after unpacking the products so that the numbers are readily available for future reference. Record field-installed kit numbers after installing the kits.

Generator Set Identification Numbers

Record the product identification numbers from the generator set nameplate(s).

Model Designation _____

Specification Number _____

Serial Number: _____

Controller Identification

Record the controller description from the generator set operation manual, spec sheet, or sales invoice.

Controller Description _____

Engine Identification

Record the product identification information from the engine nameplate.

Manufacturer _____

Model Designation _____

Serial Number _____

Accessory Number	Accessory Description

Accessory Number	Accessory Description

Table of Contents

- Safety Precautions and Instructions 7**
- Introduction 15**
- Service Assistance..... 16**
- Section 1. General 17**
- Section 2. Loading and Transporting..... 19**
 - 2.1 Lifting..... 19
 - 2.1.1 Weight and Center of Gravity 20
 - 2.1.2 Lifting the Generator Set 20
 - 2.1.3 Lifting the Subbase Fuel Tank 22
 - 2.1.4 Lifting the Generator Set with Attached Enclosure 23
 - 2.1.5 Lifting the Generator Set, Enclosure, and Subbase Fuel Tank Assembly 24
 - 2.1.6 Lifting Single Point Lift Assemblies 28
 - 2.2 Generating Set Transporting 28
- Section 3. Location 29**
 - 3.1 Location Factors 29
 - 3.2 Mounting Surface 30
 - 3.2.1 Single-Pad Mounting 31
 - 3.2.2 Dual-Pad Mounting 31
 - 3.2.3 Four-Pad Mounting 32
 - 3.2.4 Mounting Pad Specifications 32
 - 3.3 IBC Seismic Installation 32
 - 3.4 Vibration Isolation 33
 - 3.5 Dual-Bearing Alternator Alignment 36
- Section 4. Air and Cooling 37**
 - 4.1 General 37
 - 4.2 Air-Cooled Engines 37
 - 4.3 Liquid-Cooled Engines 37
 - 4.3.1 System Features 37
 - 4.3.2 Installation Considerations 37
 - 4.3.3 Recommended Coolant 39
 - 4.4 Unit-Mounted Radiator Cooling 39
 - 4.4.1 System Features 39
 - 4.4.2 Installation Considerations 39
 - 4.5 Remote Radiator Cooling 40
 - 4.5.1 General 41
 - 4.5.2 Vent Lines 43
 - 4.5.3 Fill Lines (Balance or Static) 44
 - 4.5.4 Location Considerations 44
 - 4.5.5 Installation Considerations 44
 - 4.5.6 Surge (Expansion) Tank for Horizontal Discharge Radiator 45
 - 4.5.7 Procedure to Fill with Deaeration 46
 - 4.5.8 Procedure to Fill without Deaeration 46
 - 4.5.9 Checks after Initial Startup 47
 - 4.6 City Water Cooling 47
 - 4.6.1 System Features 47
 - 4.6.2 Installation Considerations 48
 - 4.7 Cooling Tower 48
 - 4.8 Block Heaters 48

Section 5.	Exhaust System	49
5.1	Flexible Exhaust Line	49
5.2	Condensation Trap.....	50
5.3	Piping	51
5.4	Double-Sleeved Thimbles	52
5.5	Exhaust Outlet.....	52
5.6	Exhaust System Backpressure	53
Section 6.	Fuel System.....	61
6.1	Diesel Fuel Systems.....	62
6.1.1	Main Tank	63
6.1.2	Fuel Tank Monitoring Panel	64
6.1.3	Day Tanks.....	68
6.1.4	Fuel Lines	69
6.1.5	Auxiliary Fuel Pumps	69
6.2	Gas Fuel Systems, Common Components	70
6.2.1	Gas Lines.....	71
6.2.2	Gas Regulators.....	71
6.3	LP Fuel Systems	72
6.3.1	LP Gas Liquid-Withdrawal Systems.....	74
6.3.2	LP Gas Vapor-Withdrawal Systems.....	75
6.4	Natural Gas Systems	76
6.5	Combination Systems	77
6.5.1	Combination Natural Gas and LP Gas.....	77
6.5.2	Automatic Changeover Dual Fuel Systems with Reset Box.....	78
6.6	Pipe Size Requirements for Gas Fuel Systems	80
Section 7.	Electrical System	83
7.1	Generator Set Voltage Reconnection.....	84
7.2	Electrical Connections.....	84
7.3	Load Lead Connections	85
7.4	Grounding and Grounded Conductor (Neutral) Connections	86
7.5	Terminal Connector Torque	87
7.6	Batteries	88
7.7	Battery Chargers	89
7.8	Component and Accessory Power Source Requirements.....	89
7.9	Optional Accessories.....	90
7.9.1	Bus Bar Kits/Bus Lugs	90
7.9.2	Gas Fuel Valve Kit	91
7.9.3	Line Circuit Breaker	91
7.9.4	Run Relay Kit.....	92
7.9.5	Wiring Connections.....	93
Section 8.	APM402/Decision-Maker 3000 Controller Accessories	95
8.1	Accessories and Connections	95
8.1.1	Battery Charger Kit with Alarm Option	96
8.1.2	Common Fault/Failure (32A) Relay.....	97
8.1.3	Four-Input/Fifteen-Output Module.....	98
8.1.4	Gas Fuel Valve Kit	102
8.1.5	Two-Input/Five-Output Module.....	102
8.1.6	Low Fuel (Level/Pressure) Switch.....	103
8.1.7	Prime Power Switch Kit.....	104
8.1.8	Remote Emergency Stop Kit.....	105
8.1.9	Remote Reset Feature.....	106
8.1.10	Remote Serial Annunciator (RSA III)	107

8.1.11	Shunt-Trip Line Circuit Breaker.....	109
8.2	Accessory Connections.....	110
Section 9.	APM603 Controller Accessories and Connections.....	113
9.1	APM603 Controller Optional Connections.....	113
9.1.1	Run Relay.....	113
9.1.2	Factory-Defined Inputs and Outputs.....	113
9.2	Accessories and Connections.....	114
9.2.1	6-Amp Battery Charger Kit.....	114
9.2.2	10-Amp Battery Charger Temperature Compensation Kit.....	115
9.2.3	Common Fault/Failure Relay.....	116
9.2.4	Four-Input/Fifteen-Output Module.....	117
9.2.5	Digital Input/Output Modules.....	121
9.2.6	Fuel Level Sender and Fuel Leak Alarm.....	124
9.2.7	Remote Emergency Stop Kit.....	125
9.2.8	Emergency Battle Mode.....	126
9.2.9	Maintenance Mode.....	130
9.2.10	Remote Serial Annunciator (RSA III).....	134
9.2.11	Shunt-Trip Line Circuit Breaker.....	136
9.2.12	Power Distribution Switchboards.....	137
9.3	Accessory Connections.....	137
9.3.1	Controller Connections.....	137
9.3.2	Four-Input/Fifteen-Output Module.....	139
Section 10.	Decision-Maker 550 Controller Accessories.....	141
10.1	Accessories and Connections.....	141
10.1.1	Audiovisual Alarm Kit.....	141
10.1.2	Common Failure Relay Kit.....	142
10.1.3	Controller (Customer) Connection Kit.....	143
10.1.4	Float/Equalize Battery Charger Kit with Alarm Option.....	144
10.1.5	Ground Fault Annunciation.....	144
10.1.6	Idle (Speed) Mode Feature.....	147
10.1.7	Low Fuel (Level/Pressure) Switch.....	148
10.1.8	Prime Power Switch Kit.....	149
10.1.9	Remote Emergency Stop Kit.....	150
10.1.10	Remote Reset Feature.....	151
10.1.11	Remote Serial Annunciator (RSA III).....	152
10.1.12	Shunt-Trip Line Circuit Breaker.....	154
10.1.13	Single-Relay Dry Contact Kit.....	154
10.1.14	Ten-Relay Dry Contact Kit.....	155
10.1.15	Twenty-Relay Dry Contact Kit.....	156
10.2	Accessory Connections.....	158
Section 11.	Decision-Maker 3500 Controller Accessories.....	161
11.1	Accessories and Connections.....	161
11.1.1	Fifteen-Relay Dry Contact Kit.....	161
11.1.2	Remote Emergency Stop Kit.....	162
11.1.3	Remote Serial Annunciator (RSA III).....	163
11.2	Accessory Connections.....	166
Section 12.	Decision-Maker 6000 Controller Accessories.....	169
12.1	Accessories and Connections.....	169
12.1.1	Audiovisual Alarm Kit.....	169
12.1.2	Common Failure Relay Kit.....	170
12.1.3	Float/Equalize Battery Charger Kit with Alarm Option.....	171
12.1.4	Ground Fault Annunciation.....	171

12.1.5	Idle (Speed) Mode Feature	174
12.1.6	Low Fuel (Level/Pressure) Switch.....	174
12.1.7	Prime Power Switch Kit.....	175
12.1.8	Remote Emergency Stop Kit.....	176
12.1.9	Remote Reset Feature.....	178
12.1.10	Remote Serial Annunciator (RSA III)	179
12.1.11	Shunt Trip Line Circuit Breaker	181
12.1.12	Single-Relay Dry Contact Kit.....	182
12.1.13	Ten-Relay Dry Contact Kit	183
12.1.14	Twenty-Relay Dry Contact Kit.....	184
12.2	Accessory Connections.....	185
Section 13.	Remote Adjustment/Control Systems.....	189
13.1	Automatic Transfer Switches.....	190
13.2	APM402 and Decision-Maker 3000 Controller Voltage Regulator.....	190
13.3	APM603 Controller Voltage Regulator	190
13.4	APM802 Controller Voltage Regulator	190
13.5	Decision-Maker 550 Controller, Voltage Regulator and Paralleling Applications	190
13.6	Decision-Maker 3500 Controller Voltage Regulator	190
13.7	Decision-Maker 6000 Controller Voltage Regulator and Paralleling Applications	191
13.8	Decision-Maker 8000 Controller Voltage Regulator and Paralleling Applications	191
13.9	Remote Speed Adjustment	191
13.10	Remote Voltage Adjustment.....	193
13.11	Remote Wiring	195
13.12	Voltage Regulator DVR 2000 / Remote Voltage Regulator Kit, 350 kW and Above.....	195
Appendix A.	Abbreviations	197
Appendix B.	Common Hardware Application Guidelines	201
Appendix C.	Torque Specifications	203
Appendix D.	Fuel Physical Properties	205
Appendix E.	Gas Fuel Vapor Pressures	207
Appendix F.	Gas Fuel System Installation Planning	209

Safety Precautions and Instructions

IMPORTANT SAFETY INSTRUCTIONS. Electromechanical equipment, including generator sets, transfer switches, switchgear, and accessories, can cause bodily harm and pose life-threatening danger when improperly installed, operated, or maintained. To prevent accidents be aware of potential dangers and act safely. Read and follow all safety precautions and instructions. **SAVE THESE INSTRUCTIONS.**

This manual has several types of safety precautions and instructions: Danger, Warning, Caution, and Notice.



DANGER indicates a hazardous situation which, if not avoided, will result in death or serious injury.



WARNING indicates a hazardous situation which, if not avoided, could result in death or serious injury.





CAUTION indicates a hazardous situation which, if not avoided, could result in minor or moderate injury.

NOTICE

NOTICE is used to address practices not related to physical injury.

Safety decals affixed to the equipment in prominent places alert the operator or service technician to potential hazards and explain how to act safely. The decals are shown throughout this publication to improve operator recognition. Replace missing or damaged decals.

Accidental Starting

 WARNING 	Accidental starting. Can cause severe injury or death. Disconnect the battery cables before working on the generator set. Remove the negative (-) lead first when disconnecting the battery. Reconnect the negative (-) lead last when reconnecting the battery.
---	--

Disabling the generator set. Accidental starting can cause severe injury or death. Before working on the generator set or equipment connected to the set, disable the generator set as follows: (1) Move the generator set master switch to the OFF position. (2) Disconnect the power to the battery charger. (3) Remove the battery cables, negative (-) lead first. Reconnect the negative (-) lead last when reconnecting the battery. Follow these precautions to prevent starting of the generator set by an automatic transfer switch, remote start/stop switch, or engine start command from a remote computer.

(Decision-Maker® 3+ and 550 Controllers)

Disabling the generator set. Accidental starting can cause severe injury or death. Before working on the generator set or equipment connected to the set, disable the generator set as follows: (1) Press the generator set off/reset button to shut down the generator set. (2) Disconnect the power to the battery charger, if equipped. (3) Remove the battery cables, negative (-) lead first. Reconnect the negative (-) lead last when reconnecting the battery. Follow these precautions to prevent the starting of the generator set by the remote start/stop switch.

(APM402, APM603, RDC2, and Decision-Maker® 3000, 3500, and 6000 Controllers)





Disabling the generator set. Accidental starting can cause severe injury or death. Before working on the generator set or equipment connected to the set, disable the generator set as follows: (1) If the controller is not already in the MAN (manual) mode, press the Controller Mode button and then press the MAN mode button. (2) If the generator set is running, press and hold the Manual-Stop button for at least 2 seconds to stop the generator set. (3) Press the Controller Mode button and then press the controller Off mode button. (4) Disconnect the power to the battery charger, if equipped. (5) Remove the battery cables, negative (-) lead first. Reconnect the negative (-) lead last when reconnecting the battery. Follow these precautions to prevent the starting of the generator set by the remote start/stop switch.

(Decision-Maker® 8000 Controller)

Disabling the generator set. Accidental starting can cause severe injury or death. Before working on the generator set or equipment connected to the set, disable the generator set as follows: (1) Shut down the generator set. (2) Place the controller in Out of Service mode. (3) Press the emergency stop button. (4) Disconnect the power to the battery charger, if equipped. (5) Remove the battery cables, negative (-) lead first. Reconnect the negative (-) lead last when reconnecting the battery. Follow these precautions to prevent the starting of the generator set by the remote start/stop switch.

(APM802 Controller)

Battery

 WARNING 	<p>Sulfuric acid in batteries. Can cause severe injury or death.</p> <p>Wear protective goggles and clothing. Battery acid may cause blindness and burn skin.</p>
 WARNING 	<p>Explosion. Can cause severe injury or death. Relays in the battery charger cause arcs or sparks.</p> <p>Locate the battery in a well-ventilated area. Isolate the battery charger from explosive fumes.</p>



Battery electrolyte is a diluted sulfuric acid. Battery acid can cause severe injury or death. Battery acid can cause blindness and burn skin. Always wear splashproof safety goggles, rubber gloves, and boots when servicing the battery. Do not open a sealed battery or mutilate the battery case. If battery acid splashes in the eyes or on the skin, immediately flush the affected area for 15 minutes with large quantities of clean water. Seek immediate medical aid in the case of eye contact. Never add acid to a battery after placing the battery in service, as this may result in hazardous spattering of battery acid.

Battery acid cleanup. Battery acid can cause severe injury or death. Battery acid is electrically conductive and corrosive. Add 500 g (1 lb.) of bicarbonate of soda (baking soda) to a container with 4 L (1 gal.) of water and mix the neutralizing solution. Pour the neutralizing solution on the spilled battery acid and continue to add the neutralizing solution to the spilled battery acid until all evidence of a chemical reaction (foaming) has ceased. Flush the resulting liquid with water and dry the area.

Battery gases. Explosion can cause severe injury or death. Battery gases can cause an explosion. Do not smoke or permit flames or sparks to occur near a battery at any time, particularly when it is charging. Do not dispose of a battery in a fire. To prevent burns and sparks that could cause an explosion, avoid touching the battery terminals with tools or other metal objects. Remove all jewelry before servicing the equipment. Discharge static electricity from your body before touching batteries by first touching a grounded metal surface away from the battery. To avoid sparks, do not disturb the battery charger connections while the battery is charging. Always turn the battery charger off before disconnecting the battery connections. Ventilate the compartments containing batteries to prevent accumulation of explosive gases.

Battery short circuits. Explosion can cause severe injury or death. Short circuits can cause bodily injury and/or equipment damage. Disconnect the battery before generator set installation or maintenance. Remove all jewelry before servicing the equipment. Use tools with insulated handles. Remove the negative (-) lead first when disconnecting the battery. Reconnect the negative (-) lead last when reconnecting the battery. Never connect the negative (-) battery cable to the positive (+) connection terminal of the starter solenoid. Do not test the battery condition by shorting the terminals together.

Engine Backfire/Flash Fire

 WARNING	<p>Risk of fire. Can cause severe injury or death. Do not smoke or permit flames or sparks near fuels or the fuel system.</p>
	

Servicing the fuel system. A flash fire can cause severe injury or death. Do not smoke or permit flames or sparks near the fuel mixer, fuel line, fuel filter, or other potential sources of fuel vapors. When removing the fuel line or fuel system be aware that liquid propane can cause frostbite on contact.

(Gaseous-fueled Model)



Servicing the fuel system. A flash fire can cause severe injury or death. Do not smoke or permit flames or sparks near the fuel injection system, fuel line, fuel filter, fuel pump, or other potential sources of spilled fuels or fuel vapors. Catch fuels in an approved container when removing the fuel line or fuel system.

(Diesel-fueled Model)

Servicing the air cleaner. A sudden backfire can cause severe injury or death. Do not operate the generator set with the air cleaner removed.

Combustible materials. A fire can cause severe injury or death. Generator set engine fuels and fuel vapors are flammable and explosive. Handle these materials carefully to minimize the risk of fire or explosion. Equip the compartment or nearby area with a fully charged fire extinguisher. Select a fire extinguisher rated ABC or BC for electrical fires or as recommended by the local fire code or an authorized agency. Train all personnel on fire extinguisher operation and fire prevention procedures.

Exhaust System

 WARNING	<p>Carbon monoxide. Can cause severe nausea, fainting, or death. The exhaust system must be leakproof and routinely inspected.</p>
	





Generator set operation. Carbon monoxide can cause severe nausea, fainting, or death. Carbon monoxide is an odorless, colorless, tasteless, nonirritating gas that can cause death if inhaled for even a short time. Avoid breathing exhaust fumes when working on or near the generator set. Never operate the generator set inside a building unless the exhaust gas is piped safely outside. Never operate the generator set where exhaust gas could accumulate and seep back inside a potentially occupied building.

Carbon monoxide symptoms. Carbon monoxide can cause severe nausea, fainting, or death. Carbon monoxide is a poisonous gas present in exhaust gases. Carbon monoxide is an odorless, colorless, tasteless, nonirritating gas that can cause death if inhaled for even a short time. Carbon monoxide poisoning symptoms include but are not limited to the following:

- Light-headedness, dizziness
- Physical fatigue, weakness in joints and muscles
- Sleepiness, mental fatigue, inability to concentrate or speak clearly, blurred vision
- Stomachache, vomiting, nausea

If experiencing any of these symptoms and carbon monoxide poisoning is possible, seek fresh air immediately and remain active. Do not sit, lie down, or fall asleep. Alert others to the possibility of carbon monoxide poisoning. Seek medical attention if the condition of affected persons does not improve within minutes of breathing fresh air.

Fuel System

 WARNING	Explosive fuel vapors. Can cause severe injury or death.
 	Use extreme care when handling, storing, and using fuels.
 WARNING	Avoid high pressure fluids. Can cause severe injury or death.
	Do not work on high pressure fuel or hydraulic systems without protective equipment to protect hands, eyes, and body. Avoid the hazard by relieving pressure before disconnecting fuel injection pressure lines. Search for leaks using a piece of cardboard. Always protect hands, eyes, and body from high pressure fluids. If an accident occurs, seek medical attention immediately.

The fuel system. Explosive fuel vapors can cause severe injury or death. Vaporized fuels are highly explosive. Use extreme care when handling and storing fuels. Store fuels in a well-ventilated area away from spark-producing equipment and out of the reach of children. Never add fuel to the tank while the engine is running because spilled fuel may ignite on contact with hot parts or from sparks. Do not smoke or permit flames or sparks to occur near sources of spilled fuel or fuel vapors. Keep the fuel lines and connections tight and in good condition. Do not replace flexible fuel lines with rigid lines. Use flexible sections to avoid fuel line breakage caused by vibration. Do not operate the generator set in the presence of fuel leaks, fuel accumulation, or sparks. Repair fuel systems before resuming generator set operation.

Explosive fuel vapors can cause severe injury or death. Take additional precautions when using the following fuels:

Gasoline—Store gasoline only in approved red containers clearly marked GASOLINE.

Propane (LPG)—Adequate ventilation is mandatory. Because propane is heavier than air, install propane gas detectors low in a room. Inspect the detectors per the manufacturer's instructions.

Natural Gas—Adequate ventilation is mandatory. Because natural gas rises, install natural gas detectors high in a room. Inspect the detectors per the manufacturer's instructions.



Fuel tanks. Explosive fuel vapors can cause severe injury or death. Gasoline and other volatile fuels stored in day tanks or subbase fuel tanks can cause an explosion. Store only diesel fuel in tanks.

Draining the fuel system. Explosive fuel vapors can cause severe injury or death. Spilled fuel can cause an explosion. Use a container to catch fuel when draining the fuel system. Wipe up spilled fuel after draining the system.

Gas fuel leaks. Explosive fuel vapors can cause severe injury or death. Fuel leakage can cause an explosion. Check the LPG vapor or natural gas fuel system for leakage by using a soap and water solution with the fuel system test pressurized to 6–8 ounces per square inch (10–14 inches water column). Do not use a soap solution containing either ammonia or chlorine because both prevent bubble formation. A successful test depends on the ability of the solution to bubble.



LPG liquid withdrawal fuel leaks. Explosive fuel vapors can cause severe injury or death. Fuel leakage can cause an explosion. Check the LPG liquid withdrawal fuel system for leakage by using a soap and water solution with the fuel system test pressurized to at least 90 psi (621 kPa). Do not use a soap solution containing either ammonia or chlorine because both prevent bubble formation. A successful test depends on the ability of the solution to bubble.



Hazardous Noise

 CAUTION	<p>Hazardous noise. Can cause hearing loss.</p> <p>Never operate the generator set without a muffler or with a faulty exhaust system.</p>
	

Engine noise. Hazardous noise can cause hearing loss. Generator sets not equipped with sound enclosures can produce noise levels greater than 105 dBA. Prolonged exposure to noise levels greater than 85 dBA can cause permanent hearing loss. Wear hearing protection when near an operating generator set.

Hazardous Voltage/Moving Parts

 DANGER	<p>Hazardous voltage. Will cause severe injury or death.</p> <p>Disconnect all power sources before opening the enclosure.</p>
	

 DANGER	<p>Hazardous voltage. Moving parts. Will cause severe injury or death.</p> <p>Operate the generator set only when all guards and electrical enclosures are in place.</p>
 	

 WARNING	<p>Hazardous voltage. Backfeed to the utility system. Can cause property damage, severe injury, or death.</p> <p>If the generator set is used for standby power, install an automatic transfer switch to prevent inadvertent interconnection of standby and normal sources of supply.</p>
	

Servicing the generator set when it is operating. Exposed moving parts will cause severe injury or death. Keep hands, feet, hair, clothing, and test leads away from the belts and pulleys when the generator set is running. Replace guards, screens, and covers before operating the generator set.

Grounding electrical equipment. Hazardous voltage will cause severe injury or death. Electrocutation is possible whenever electricity is present. Ensure you comply with all applicable codes and standards. Electrically ground the generator set and related equipment and electrical circuits. Turn off the main circuit breakers of all power sources before servicing the equipment. Never contact electrical leads or appliances when standing in water or on wet ground because these conditions increase the risk of electrocutation.

Installing the battery charger. Hazardous voltage will cause severe injury or death. An ungrounded battery charger may cause electrical shock. Connect the battery charger enclosure to the ground of a permanent wiring system. As an alternative, install an equipment grounding conductor with circuit conductors and connect it to the equipment grounding terminal or the lead on the battery charger. Install the battery charger as prescribed in the equipment manual. Install the battery charger in compliance with local codes and ordinances.

Connecting the battery and the battery charger. Hazardous voltage will cause severe injury or death. Reconnect the battery correctly, positive to positive and negative to negative, to avoid electrical shock and damage to the battery charger and battery(ies). Have a qualified electrician install the battery(ies).

Short circuits. Hazardous voltage/current will cause severe injury or death. Short circuits can cause bodily injury and/or equipment damage. Do not contact electrical connections with tools or jewelry while making adjustments or repairs. Remove all jewelry before servicing the equipment.

Engine block heater. Hazardous voltage will cause severe injury or death. The engine block heater can cause electrical shock. Remove the engine block heater plug from the electrical outlet before working on the block heater electrical connections.



Electrical backfeed to the utility. Hazardous backfeed voltage can cause severe injury or death. Install a transfer switch in standby power installations to prevent the connection of standby and other sources of power. Electrical backfeed into a utility electrical system can cause severe injury or death to utility personnel working on power lines.



Testing live electrical circuits. Hazardous voltage or current will cause severe injury or death. Have trained and qualified personnel take diagnostic measurements of live circuits. Use adequately rated test equipment with electrically insulated probes and follow the instructions of the test equipment manufacturer when performing voltage tests. Observe the following precautions when performing voltage tests: (1) Remove all jewelry. (2) Stand on a dry, approved electrically insulated mat. (3) Do not touch the enclosure or components inside the enclosure. (4) Be prepared for the system to operate automatically. *(600 volts and under)*

 CAUTION	
Welding the generator set. Can cause severe electrical equipment damage.	
Welding on generator set will cause serious damage to engine electronic controls components. Disconnect all engine electronic control connections before welding.	





Welding on the generator set. Can cause severe electrical equipment damage. Before welding on the generator set perform the following steps: (1) Remove the battery cables, negative (-) lead first. (2) Disconnect all engine electronic control module (ECM) connectors. (3) Disconnect all generator set controller and voltage regulator circuit board connectors. (4) Disconnect the engine battery-charging alternator connections. (5) Attach the weld ground connection close to the weld location.

Heavy Equipment

 WARNING	Unbalanced weight. Improper lifting can cause severe injury or death and equipment damage.
	Do not use lifting eyes. Lift the generator set using lifting bars inserted through the lifting holes on the skid.

 WARNING	Lifting eye failure. Improper lifting can cause severe injury or death and equipment damage
	Do not lift the generator set from the engine or alternator eyes. Never stand under a unit being lifted. Always maintain a safe distance from the unit being lifted. See the lifting instructions in the installation manual that was provided with the unit.

Hot Parts

 WARNING	<p>Hot coolant and steam. Can cause severe injury or death.</p> <p>Before removing the pressure cap, stop the generator set and allow it to cool. Then loosen the pressure cap to relieve pressure. Fill system before starting unit.</p>
	
 WARNING	<p>Hot engine and exhaust system. Can cause severe injury or death.</p> <p>Do not work on the generator set until it cools.</p>
	

Servicing the exhaust system. Hot parts can cause severe injury or death. Do not touch hot engine parts. The engine and exhaust system components become extremely hot during operation.

Servicing the engine heater. Hot parts can cause minor personal injury or property damage. Install the heater before connecting it to power. Operating the heater before installation can cause burns and component damage. Disconnect power to the heater and allow it to cool before servicing the heater or nearby parts.

Notice

NOTICE
<p>This generator set has been rewired from its nameplate voltage to:</p> <div style="border: 1px solid black; height: 20px; width: 100%;"></div>
246242

NOTICE

Voltage reconnection. Affix a notice to the generator set after reconnecting the set to a voltage different from the voltage on the nameplate. Order voltage reconnection decal 246242 from an authorized service distributor/dealer.

NOTICE

Parallel Operation. This product includes features intended to support operation in parallel with the utility grid, but these features have not been evaluated for compliance with specific utility interconnection protection standards or requirements.

NOTICE

Canadian installations only. For standby service connect the output of the generator set to a suitably rated transfer switch in accordance with Canadian Electrical Code, Part 1.

NOTICE

Electrostatic discharge damage. Electrostatic discharge (ESD) damages electronic circuit boards. Prevent electrostatic discharge damage by wearing an approved grounding wrist strap when handling electronic circuit boards or integrated circuits. An approved grounding wrist strap provides a high resistance (about 1 megohm), not a direct short, to ground.

Notes

This manual provides installation instructions for industrial generator sets. KD Series and Model CCL generator sets have separate installation manuals. Operation manuals and wiring diagram manuals are available separately. See Related Literature for document numbers.

Some additional model-specific installation information may be included in the respective generator set controller operation manual.

Information in this publication represents data available at the time of print. Discovery Energy, LLC and its affiliates dba Rehiko reserves the right to change this publication and the products represented without notice and without any obligation or liability whatsoever.

Read this manual and carefully follow all procedures and safety precautions to ensure proper equipment operation and to avoid bodily injury. Read and follow the Safety Precautions and Instructions section at the beginning of this manual. Keep this manual with the equipment for future reference.

Abbreviations

This publication makes use of numerous abbreviations. Typically, the word(s) are spelled out along with the abbreviation in parentheses when shown for the first time in a section. Refer to the Abbreviations section in the Appendices for abbreviation definitions.

Related Literature

Separate literature contains communication, firmware, and other additional information not provided in this manual. Figure 1 lists the available literature part numbers.

Manual Description	Literature Part No.
Generator Set/Controller Wiring Diagram Manual	Multiple Part Numbers Contact your Distributor/Dealer
Monitor III Converters, Connections, and Controller Setup	TT-1405
Monitor III Software Spec Sheet	G6-76
Monitor III Converter, Modbus®/Ethernet Spec Sheet	G6-79
Monitor III Software Operation Manual	TP-6347
Modbus® Communications Protocol Operation Manual	TP-6113
Protocol Manual, APM603 Controller	TP-7151
Program Loader Software Installation	TT-1285
SiteTech™ Software Operation Manual	TP-6701
Remote Serial Annunciator (RSA)	TT-1625
Decision-Maker® Paralleling System (DPS) Spec Sheet	G6-110
Decision-Maker® Paralleling System (DPS) Operation Manual	TP-6747
Commissioning Manual, APM603 Controller	TP-7131
Battery Charger, 10 amp float/equalize	TP-7077
Battery Charger, 6 amp float/equalize	TT-1702
Battery Charger, ESCR II	TP-7025
APM802 Operation Manual	TP-7070
KD700 – KD3250 Installation Manual	TP-7153
25CCL – 36CCL Installation Manual	TP-7119

Figure 1 Related Literature

For professional advice and conscientious service, please contact your nearest authorized distributor or dealer.

- Visit the company website at powersystems.rehiko.com.
- Look at the labels and decals on your product or review the appropriate literature or documents included with the product.
- Call toll free in the US and Canada 1-800-544-2444.
- Outside the US and Canada, call the nearest regional office.

Headquarters Europe, Middle East, Africa (EMEA)

EMEA Headquarters
Netherlands B.V.
Kristallaan 1
4761 ZC Zevenbergen
The Netherlands
Phone: (31) 168 331630
Fax: (31) 168 331631

Asia Pacific

Asia Pacific Headquarters
Singapore, Republic of Singapore
Phone: (65) 6264-6422
Fax: (65) 6264-6455

China

North China Regional Office, Beijing
Phone: (86) 10 6518 7950
(86) 10 6518 7951
(86) 10 6518 7952
Fax: (86) 10 6518 7955

East China Regional Office, Shanghai
Phone: (86) 21 6288 0500
Fax: (86) 21 6288 0550

India, Bangladesh, Sri Lanka

India Regional Office
Bangalore, India
Phone: (91) 80 3366208
(91) 80 3366231
Fax: (91) 80 3315972

Japan, Korea

North Asia Regional Office
Tokyo, Japan
Phone: (813) 3440-4515
Fax: (813) 3440-2727

Section 1. General

Industrial power systems give years of dependable service if installed using the guidelines provided in this manual and in applicable codes. Incorrect installation can cause continuing problems. Figure 2 illustrates a typical installation.

Your authorized generator set distributor/dealer may also provide advice about or assistance with your installation.

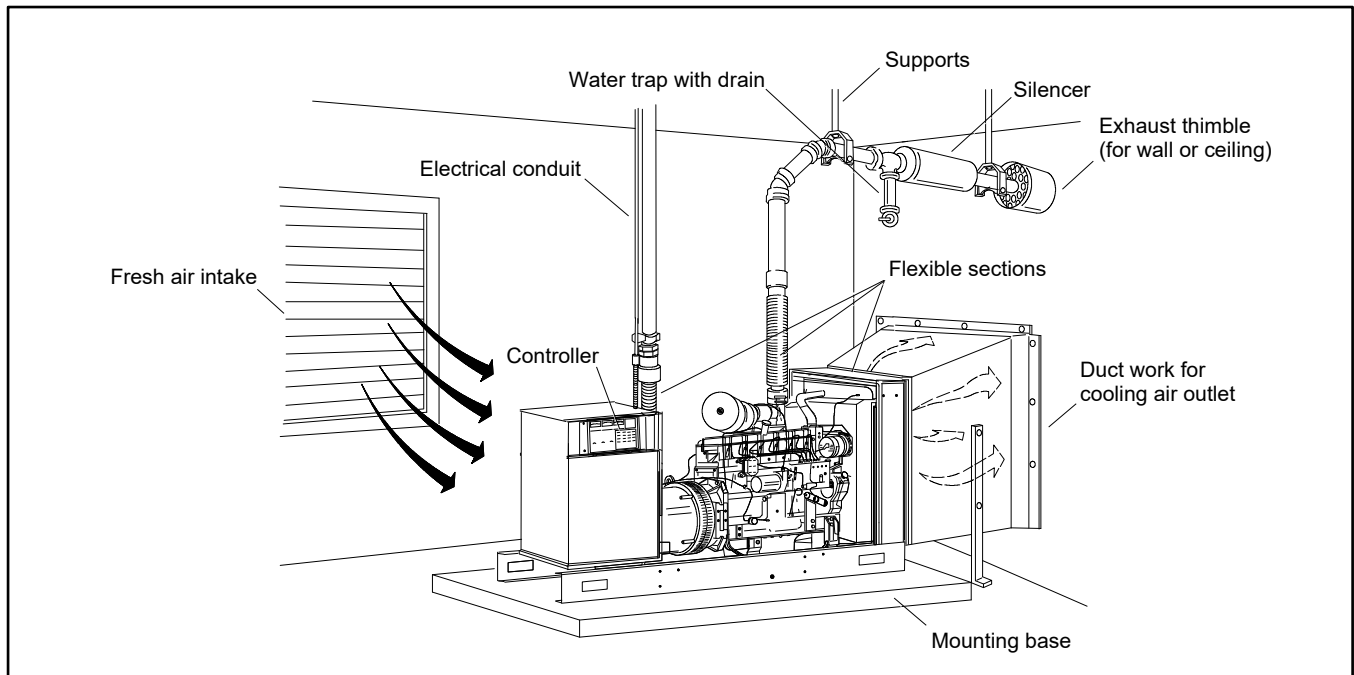

Figure 2 Typical Stationary-Duty Generator Set Installation

This manual references several organizations and their codes that provide installation requirements and guidelines such as the National Fire Protection Association (NFPA) and Underwriter's Laboratories Inc. (UL).

- NFPA 54 National Fuel Gas Code
- NFPA 70 National Electrical Code; the National Electrical Code is a registered trademark of the NFPA
- NFPA 99 Standard for Health Care Facilities
- NFPA 101 Life Safety Code
- NFPA 110 Emergency and Standby Power Systems
- UL 486A-486B Wire Connectors
- UL 486E Equipment Wiring Terminals for Use with Aluminum and/or Copper Conductors
- UL 2200 Stationary Engine Generator Assemblies

These organizations provide information specifically for US installations. Installers must comply with all applicable national and local codes.

Before beginning generator set installation, record the following data from the generator set's specification sheet and keep this data accessible for reference during installation:

- Dimensions and weight (verify dimensions and weight using the submittal data)
- Exhaust outlet size and maximum allowable backpressure
- Battery CCA rating and quantity
- Fuel supply line size and fuel pressure requirement (gas models)
- Air requirements



Notes

Section 2. Loading and Transporting

The loading and transporting processes expose the generator set to many stresses and the possibility of improper handling. Therefore, after transporting industrial generator sets:

- Check the alignment of the radiator and supports to ensure that the radiator is evenly spaced from the generator and that supports are square and of even length. Check the radiator fan for uniform alignment and equal clearance within the radiator shroud. Adjust if necessary.
- After confirming the correct alignment, tighten the hardware to its specified torque. Reference “Torque Specifications” in the appendix.

2.1 Lifting

 WARNING	Lifting eye failure. Improper lifting can cause severe injury or death and equipment damage
	Do not lift the generator set from the engine or alternator eyes. Never stand under a unit being lifted. Always maintain a safe distance from the unit being lifted. See the lifting instructions in the installation manual that was provided with the unit.

Follow these general precautions when lifting all generator sets and related equipment.

- Install proper size rigging at the skid lifting eyes providing a direct pull on the skid lifting eye. Make sure the rigging does not work as a pry bar lever against the lifting eye.
- Do not lift the generator set using the lifting eyes attached to the engine, alternator, or the top of the radiator as these lifting eyes cannot support the total weight of the generator set.
- Always protect cables, chains, and straps from sharp edges.

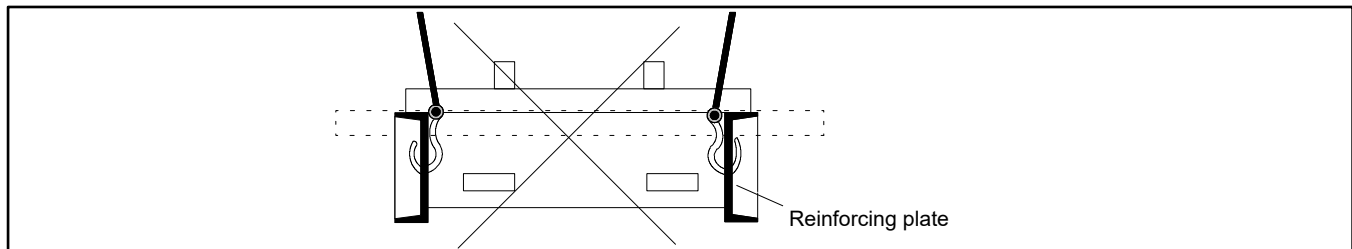

Figure 3 Improper Lifting Hook Placement (above 1000 kW)

- Generator sets typically above 1000 kW may have reinforcing plates on the skid. Do not attach lifting hooks to the reinforcing plate. See Figure 3.
- Lifting should only be conducted by those trained and experienced in lifting and rigging to achieve a safe and effective lift. Consideration needs to be given to, but not necessarily limited to, the following items:
 - Weight and center of gravity of the equipment being lifted
 - Weight and center of gravity of the lifting device
 - Boom angles
 - Selection of rated rigging
 - Stability of lifting foundation
 - Wind and weather conditions
 - Local or regional codes that may require or restrict types of rigging.
- Use a spreader bar to prevent lifting cables from contacting air cleaners, shrouds, and other protruding components. If the cables still do not clear these components, remove the components.

2.1.1 Weight and Center of Gravity

Refer to the respective specification sheet and/or the submittal drawing for the weight and center of gravity of all components being lifted. The total combined weight and center of gravity must be known to select the proper rigging. If the weight and center of gravity is not readily available, contact your distributor/dealer.

As applicable, determine the weight and center of gravity of the following components:

- Generator set
- Enclosure system (includes silencer, inlet baffles, louvers, etc.)
- Subbase fuel tank (lift only empty fuel tanks)

2.1.2 Lifting the Generator Set

The distributor/lifting contractor should choose one of the following methods to lift the generator set depending upon the location circumstances and the generator set's weight and size. Remove cover plates as needed to access the generator set skid lifting eyes.

- See Figure 4 for the spreader bar and hook methods.
- See Figure 5 for the spreader bar and skid lifting bar methods.

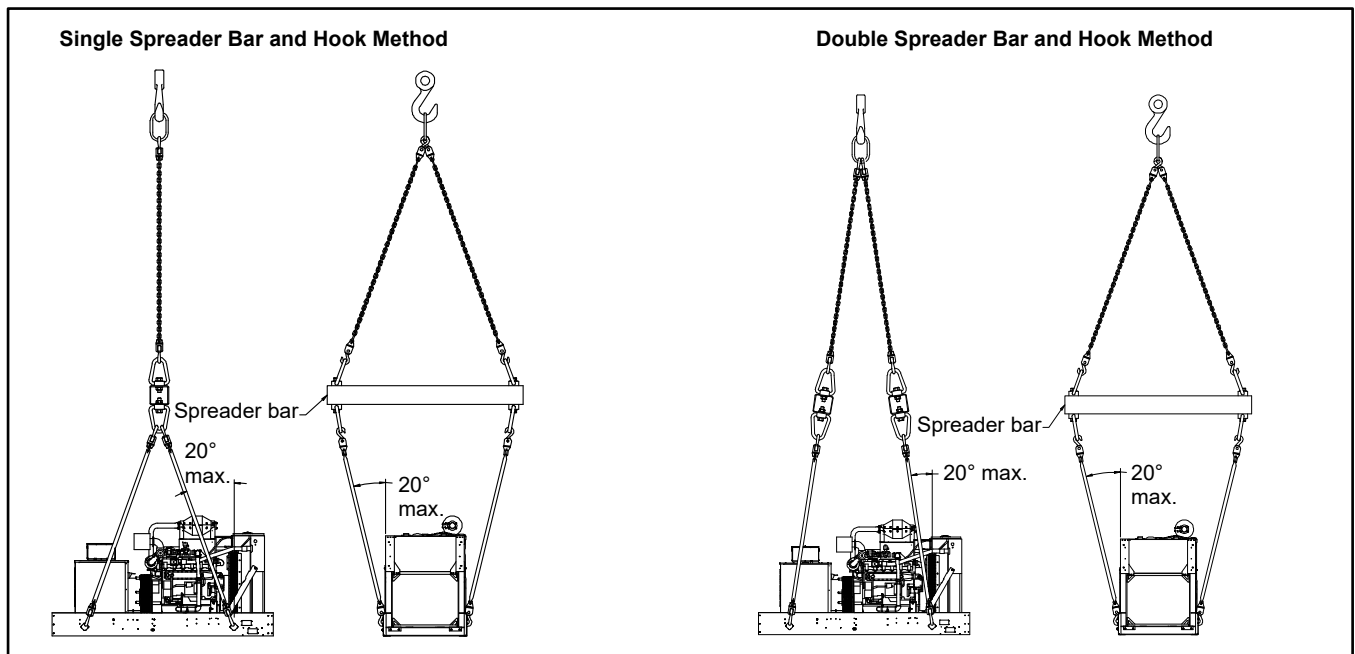

Figure 4 Single and Double Spreader Bar and Hook Method

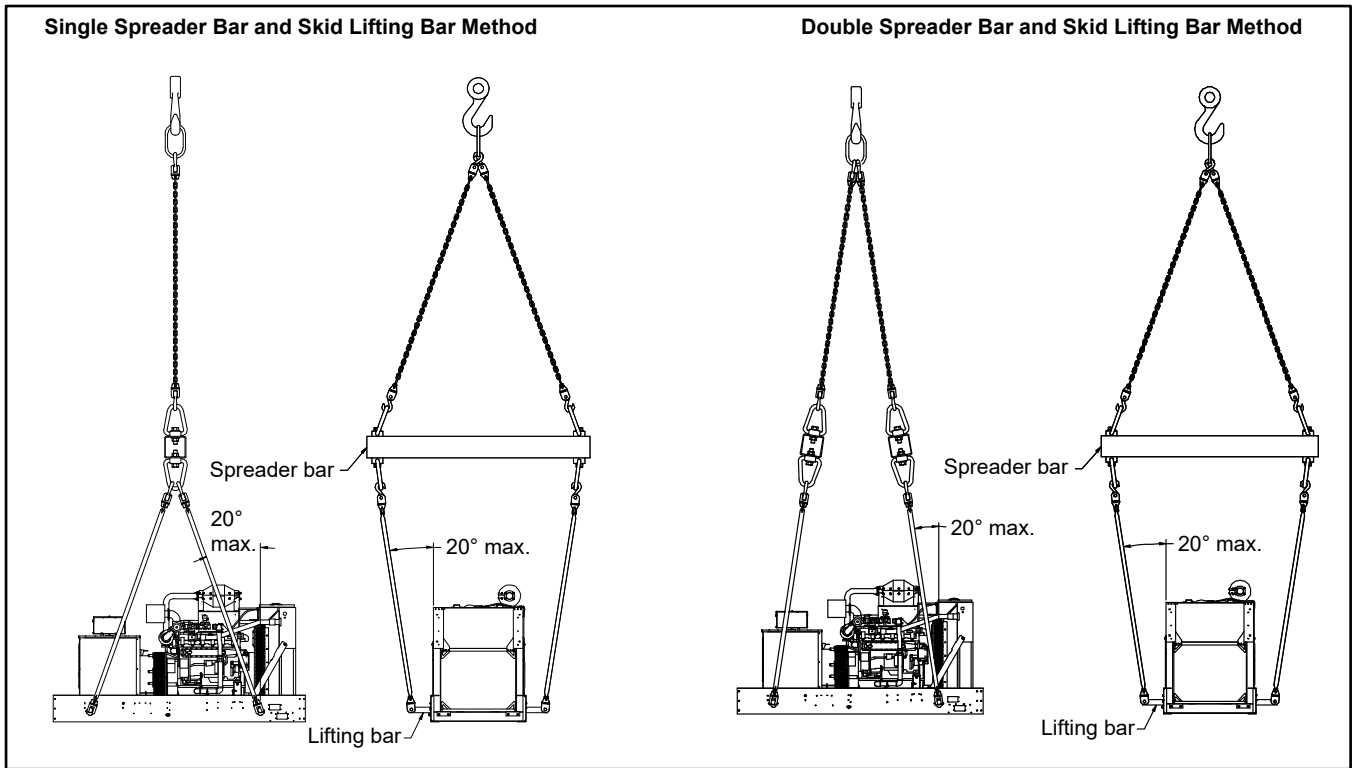

Figure 5 Single and Double Spreader Bar and Skid Lifting Bar Method

2.1.3 Lifting the Subbase Fuel Tank

This section deals with lifting the subbase fuel tank as a single unit.

- The subbase fuel tank must have lifting eyes in order to use the following methods.
- The subbase fuel tank must be empty. Do not lift a fuel tank containing fuel (or any liquid).
- Remove any vent piping longer than 1 m (3.3 ft.) from the fuel tank. Do not lift a fuel tank with attached vent piping longer than 1 m (3.3 ft.).
- Attach one or two spreader bars as shown.

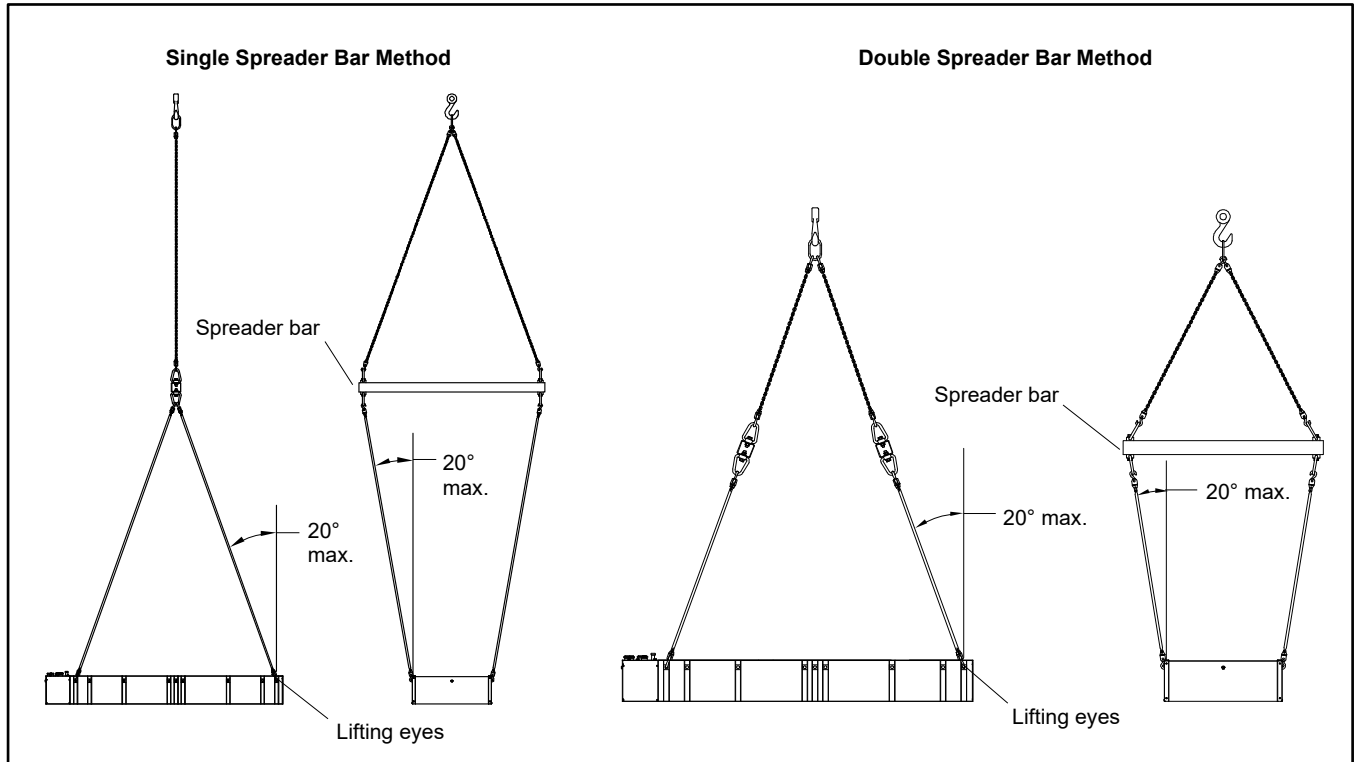

Figure 6 Fuel Tank with Single and Double Spreader Bar Method

2.1.4 Lifting the Generator Set with Attached Enclosure

Enclosure Attached Directly to the Generator Set Skid

Refer to Figure 7. Lift the assembly by lifting on the skid as shown in the previous section on Lifting the Generator Set.

Do not attach hoisting equipment to the enclosure.

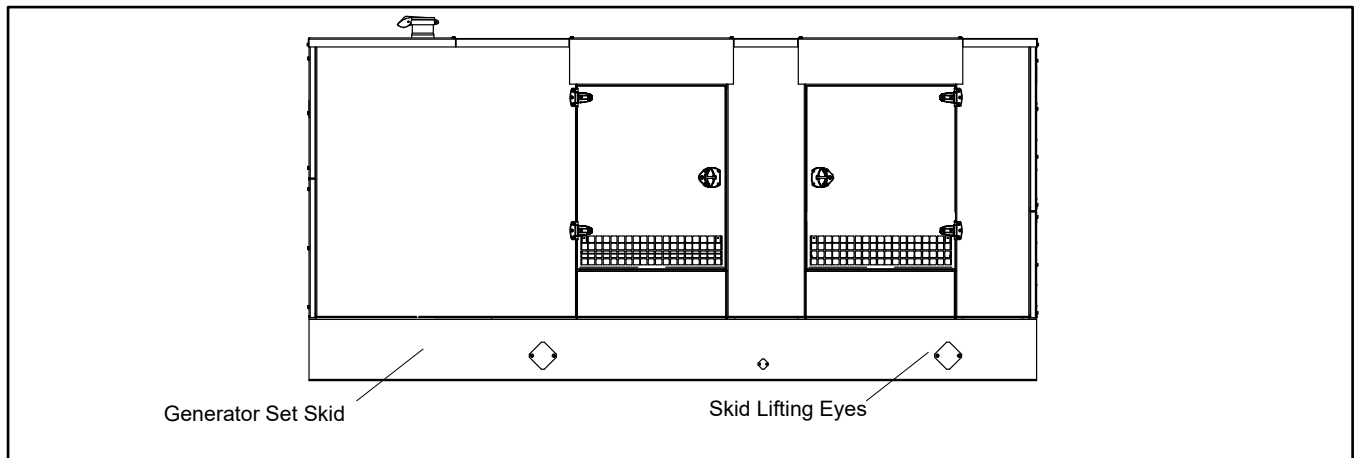

Figure 7 Typical Enclosure Attached Directly to the Generator Set Skid

Enclosure Attached Directly to the Subbase Fuel Tank

Refer to Figure 8. Lift the assembly by lifting on the subbase fuel tank lifting eyes. Lift using all of the lifting eyes provided on the subbase fuel tank. Select the procedure from the following illustrations based on the matching number of available subbase fuel tank lifting eyes.

Do not attach hoisting equipment to the enclosure.

Enclosure Attached to the Enclosure Base and Assembled to the Subbase Fuel Tank

Refer to Figure 9.

With the subbase fuel tank detached from the enclosure base, lift only the enclosure and generator set using the enclosure base lifting eyes. Lift using all of the lifting eyes provided on the enclosure base. Select the procedure from the following illustrations based on the matching number of available enclosure base lifting eyes.

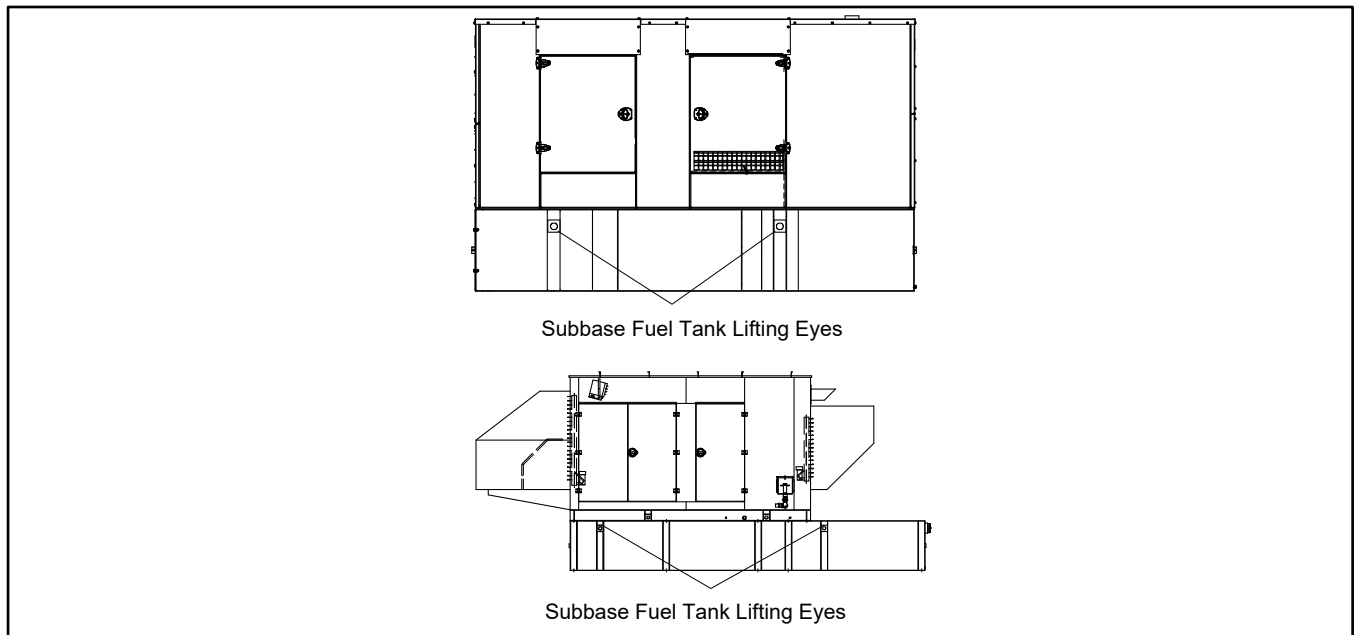

Figure 8 Typical Enclosure Attached Directly to the Subbase Fuel Tank

Lift the entire enclosure, generator set, and subbase fuel tank assembly by lifting on the subbase fuel tank lifting eyes. Lift using all of the lifting eyes provided on the subbase fuel tank. Select the procedure from the following illustrations based on the matching number of available subbase fuel tank lifting eyes. Do not attach hoisting equipment to the enclosure base.

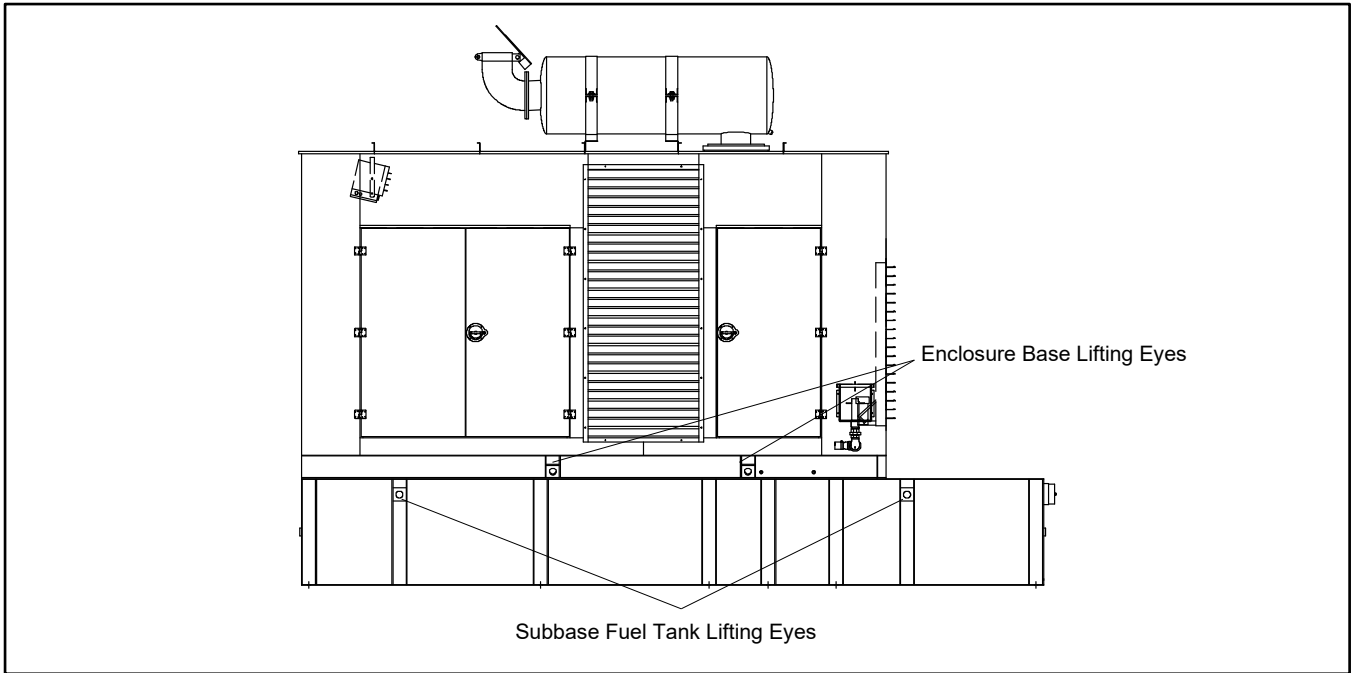

Figure 9 Typical Enclosure Attached to the Enclosure Base and Assembled to the Subbase Fuel Tank

2.1.5 Lifting the Generator Set, Enclosure, and Subbase Fuel Tank Assembly

When using the subbase fuel tank to lift the generator set and/or enclosure as a package, use ALL of the lifting eyes on the subbase fuel tank.

2.1.5.1 Four Eye Lifting Method

Hoisting using Four Eye Lifting Method

Apply the same lifting methods using single or double spreader bars as shown in the previous section, Lifting the Generator Set.

2.1.5.2 Six Eye Lifting Method

Hoisting using Six Eye Lifting Method

Apply one spreader bar and two chain falls or three spreader bars and two chain falls for six eyes lifting.

- Install a pair of outer slings to the maximum angle as shown in Figure 10.
- Remove the slack from the slings in the system but do not lift the unit.
- Install adjustable chain falls and strap or cable them from the spreader bar to the middle lifting eyes. Adjust to remove the slack.
- Check and remove any slack that has developed in the primary slings and check that all chains/straps/cables are carrying load.

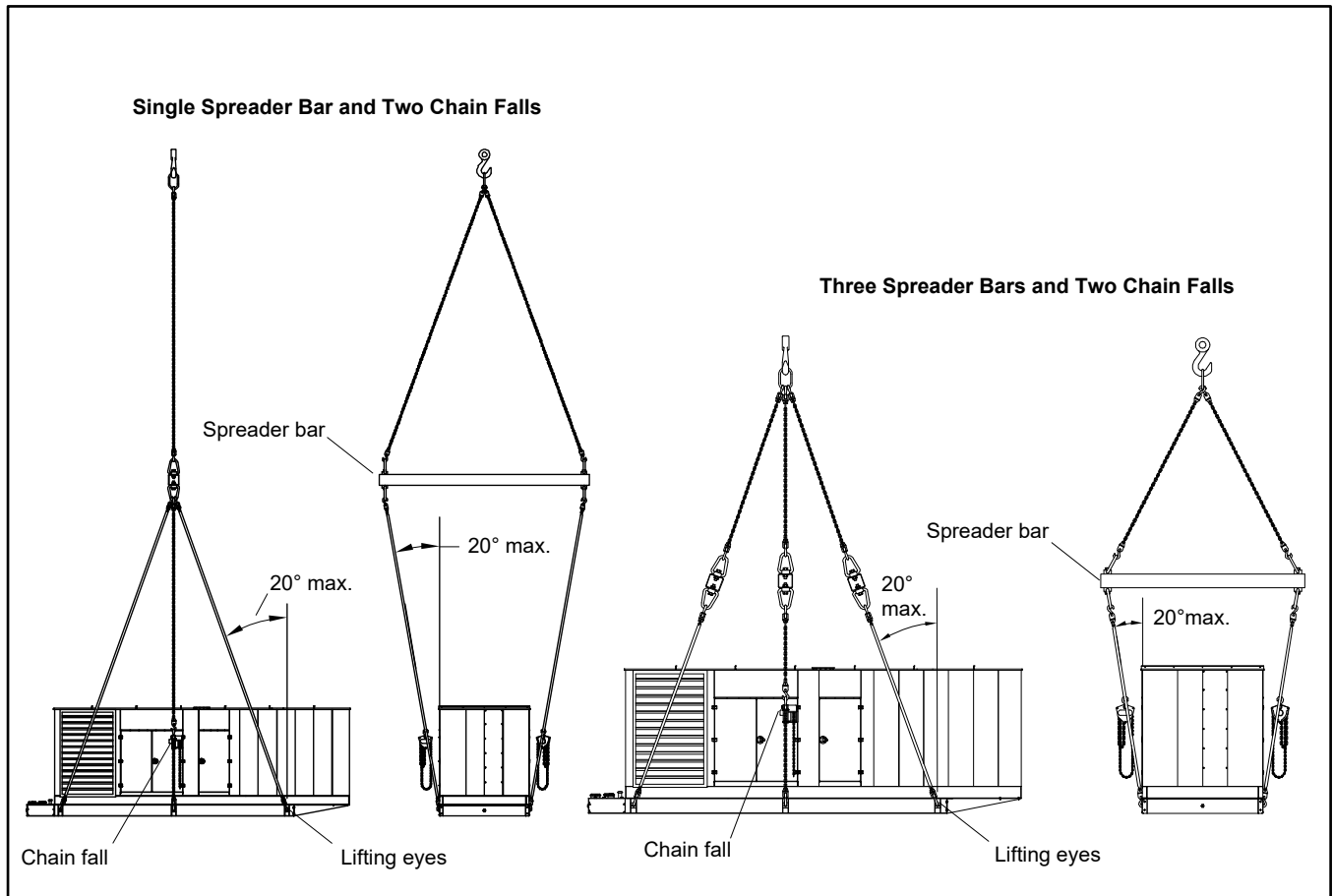

Figure 10 Six Eye Lifting Methods

2.1.5.3 Eight Eye Lifting Method

Hoisting using Eight Eye Lifting Method

- Apply two spreader bars and four chain falls (Figure 11) for eight eye lifting.
- Install a pair of outer slings up to the maximum angle as shown in Figure 11.
- Remove the slack from the slings in the system but do not lift the unit.
- Install adjustable chain falls and strap or cable them from the spreader bar to the middle lifting eyes. Adjust to remove the slack.
- Check and remove any slack that has developed in the primary slings and check that all chains/straps/cables are carrying load.

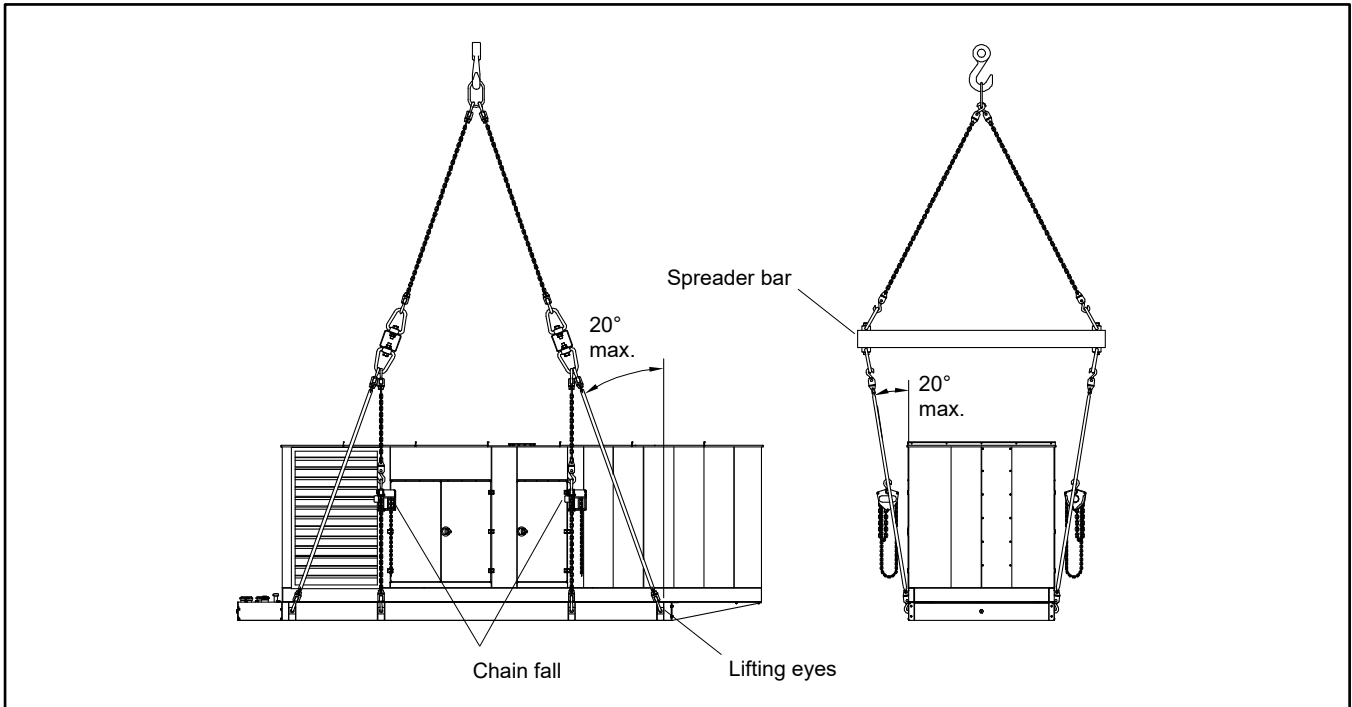

Figure 11 Eight Eyes, Two Spreader Bars, and Four Chain Falls Lifting Method

2.1.5.4 Ten Eye Lifting Method

Hoisting using Ten Eye Lifting Method

Apply three spreader bars and six chain falls for ten eye lifting.

- Install a pair of outer slings up to the maximum angle as shown in Figure 12.
- Remove the slack from the slings in the system but do not lift the unit.
- Install adjustable chain falls and strap or cable them from the spreader bar to the middle lifting eyes. Adjust to remove the slack.
- Check and remove any slack that has developed in the primary slings and check that all chains/straps/cables are carrying load.

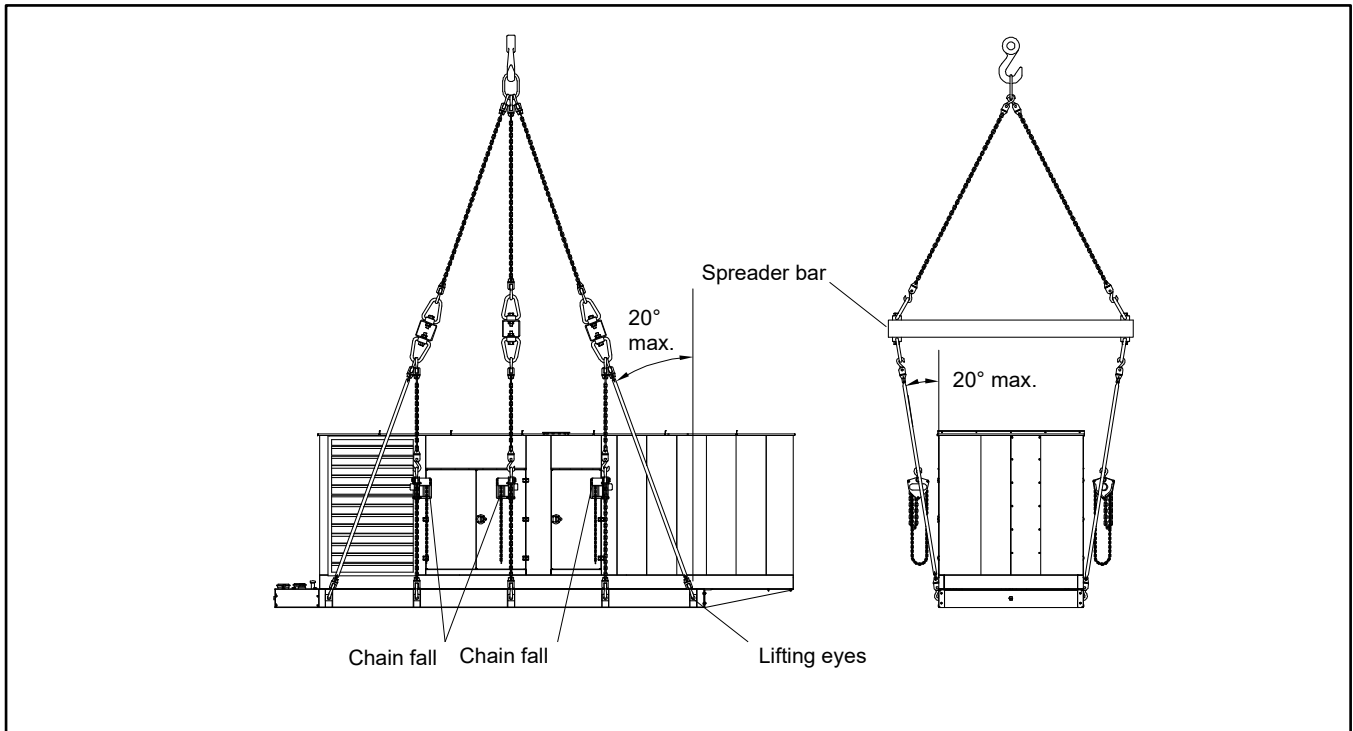

Figure 12 Ten Eyes, Three Spreader Bars, and Six Chain Falls Lifting Method

2.1.5.5 Twelve Eye Lifting Method

Hoisting using Twelve Eye Lifting Method

Apply three spreader bars and eight chain falls for twelve eye lifting.

- Install a pair of outer slings up to the maximum angle as shown in Figure 13.
- Remove the slack from the slings in the system but do not lift the unit.
- Install adjustable chain falls and strap or cable them from the spreader bar to the middle lifting eyes. Adjust to remove the slack.
- Check and remove any slack that has developed in the primary slings and check that all chains/straps/cables are carrying load.

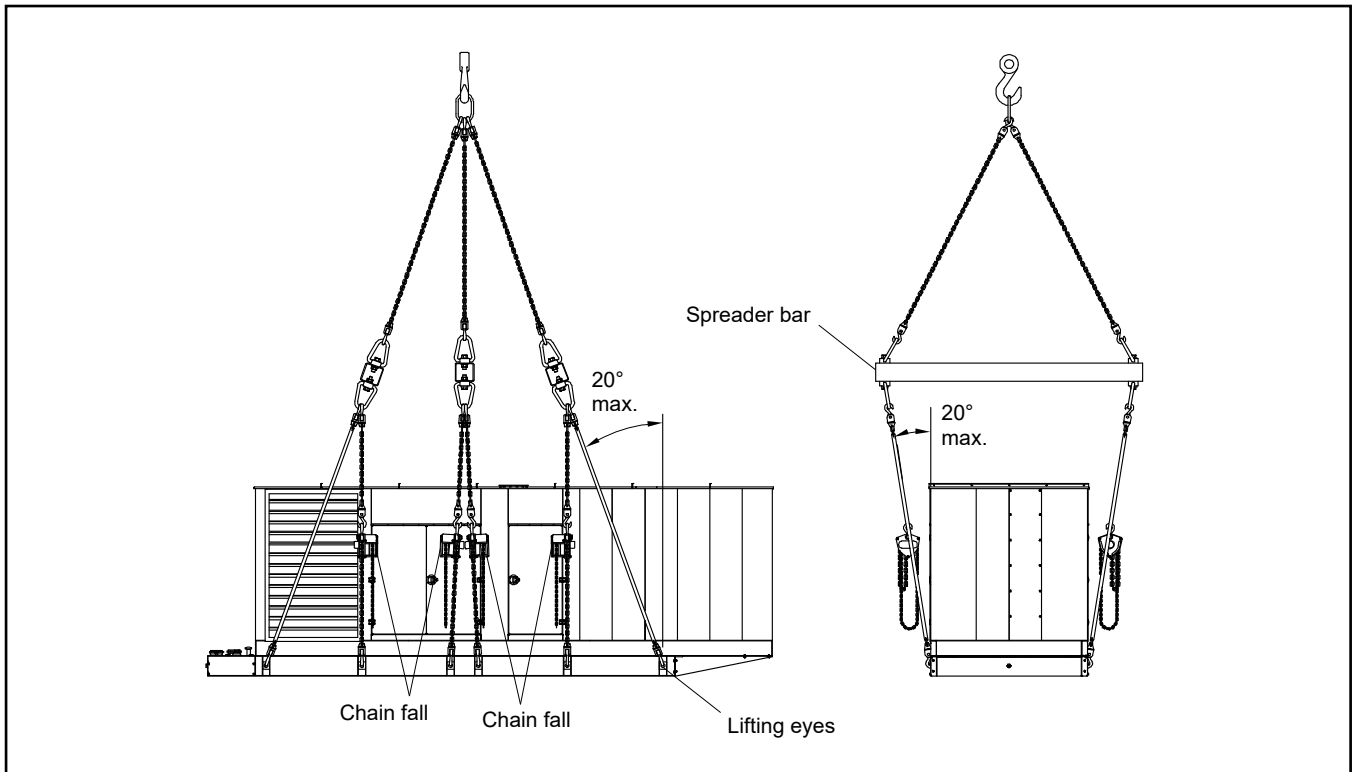

Figure 13 Twelve Eyes, Three Spreader Bars, and Eight Chain Falls Lifting Method

2.1.6 Lifting Single Point Lift Assemblies

Some units have an enclosure integral to the skid and attach a single point lifting eye located at the top and center of the enclosure. The entire assembly may be lifted with this eye.

2.2 Generating Set Transporting

Follow these guidelines when transporting the generator set:

- Select the transporting vehicle/trailer based on the dimensions and weight of the generator set as specified in the generator set dimension drawing or specification sheet. Ensure that the gross weight and overall height of the generator set and vehicle/trailer in transport does not exceed applicable transportation codes.
- Use low boy-type trailers that meet clearance requirements when transporting units larger than 1000 kW. Load large (unboxed) radiator-equipped generator sets with the radiator facing the rear to reduce wind resistance during transit. Secure fans to prevent fan rotation in transit.
- Securely fasten the generator set to the vehicle/trailer. Even the heaviest of generator sets can move during shipment unless they are secured. Fasten the generator set to the vehicle/trailer bed with a correctly sized chain routed through the mounting holes of the generator set skid (or tank, if equipped). Use chain tighteners to remove slack from the mounting chain. Do not use strapping over the top of an enclosed generator set as damage to the enclosure may occur.
- Always cover a non-enclosed unit with a heavy-duty canvas or tarpaulin secured to the generator set or trailer.

3.1 Location Factors

Ideally, the generator set should be mounted on concrete at ground level. For above-ground installations, including roof installations, weight considerations are especially important. The building engineer determines whether the structure can support the weight of the generator set.

The location of the generator set must meet the following criteria.

General:

- Mounting surface is square and horizontally level at all four edges.
- Support the weight of the generator set and related equipment such as fuel storage tanks, batteries, radiators, and mounting pad(s). Keep in mind that the mounting pad weight may exceed the weight of the generator set.
- Mounting pad should be designed to prevent the vibration of a running unit from causing mounting pad distortion and affecting engine/alternator alignment.
- Meet applicable fire rating codes and standards.
- Install the unit so that the risk of contact by people with the hot generator set surfaces is minimized.
- Position the generator set over a noncombustible surface. If the mounting surface directly under or near the generator set is porous or deteriorates from exposure to engine fluids, construct a containment pan for spilled fuel, oil, coolant, and battery electrolyte. Do not allow accumulation of combustible materials under the generator set.
- Permit vibration isolation and dampening to reduce noise and prevent damage.
- Be clean, dry, and not subject to flooding.
- Provide easy access for service and repair.

Indoor Installations:

- Allow adequate ventilation with a minimum amount of ductwork. Refer to the generator spec sheet.
- Allow safe expulsion of exhaust.
- Allow for storage of sufficient fuel to sustain emergency operation. See the generator set specification sheet for fuel consumption.
- Allow for locating the fuel tank within the vertical lift capabilities of the fuel pump and any auxiliary pumps. See the section on Fuel Systems.
- Minimize the risk of public or unauthorized access.
- Provide adequate protection to prevent injury in the stub-up area. If the stub-up area opening is exposed, provide a cover or fill in the area to avoid the risk of tripping or falling into the stub-up opening.

Outdoor Installations:

- Select a location that provides adequate air flow. Avoid locations next to tall buildings that block normal air flow and cause air vacuum pockets. Avoid areas that are subject to high winds, excessive dust, or other airborne contaminants. High dust areas may require more frequent air cleaner maintenance. High temperature conditions affect generator set efficiency. Select a shaded area away from direct sunlight and/or other heat-producing equipment when practical.
- Avoid areas with combustible materials, including but not limited to building materials as well as natural surroundings. Keep dry field grass, foliage, and combustible landscaping materials a safe distance from the exhaust system.
- The subsoil location must have a bearing strength capable of supporting the generator set and mounting pad combined weight. Analysis by a qualified technician or engineer is recommended to determine the proper excavation material required.

- If the generator set enclosure is mounted on multiple pads where it is elevated above the main surface it may cause discharge air recirculation underneath the unit. A typical location could be a building roof where the main surface is uneven for a single pad. In the following section on Air and Cooling, refer to “Installation Considerations” under Liquid-Cooled Engines for information to minimize discharge air recirculation.
- Select a location that provides adequate space to access and service the unit. Allow for adequate clearance to open and close access doors. Avoid locations on a hill or steep embankment unless provision is made to include a servicing platform.

Coastal Seawater and High Humidity Climates:

Ocean spray and humidity can cause corrosive damage to alternator windings.

- Select an alternator with a thixotropic coating to protect the windings.
- Select an alternator with a strip heater to reduce humidity.

3.2 Mounting Surface

Figure 14 shows typical mounting surface details for sizing the concrete surface beyond the generator set and allowing for clearances during generator set service. Follow the dimensional details for single-pad, dual pad, or four-pad mounting depending upon the mounting method. Refer to the following sections for the applicable mounting method.

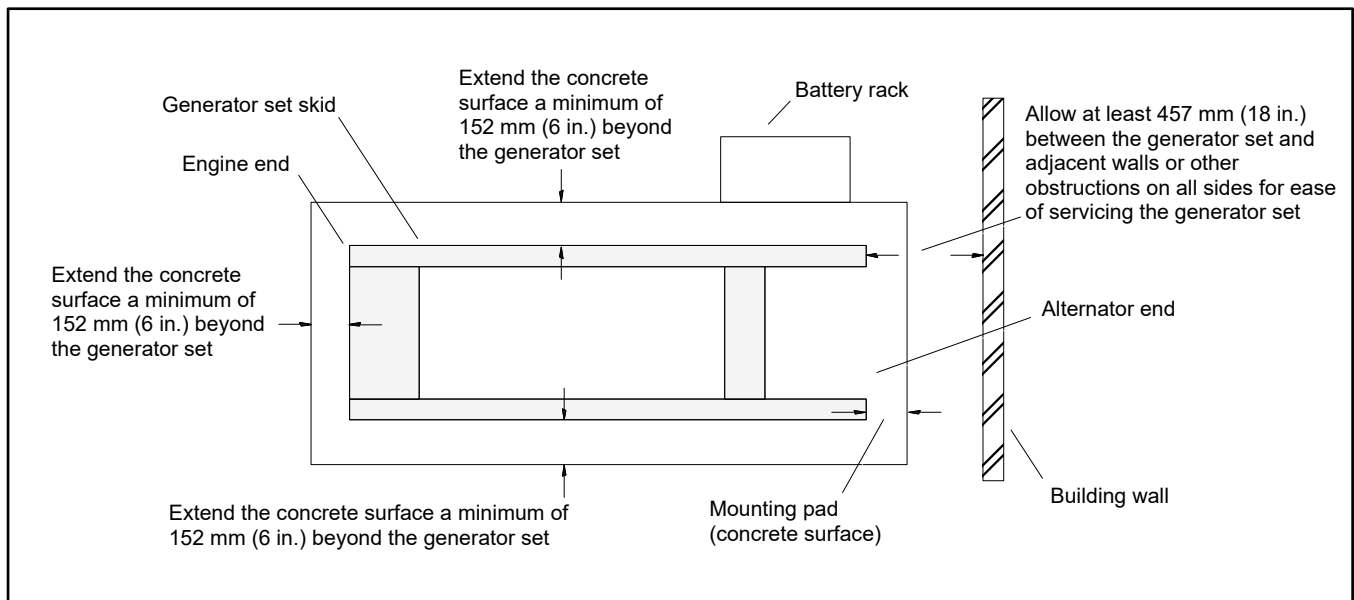

Figure 14 Mounting Surface Detail (top view)

3.2.1 Single-Pad Mounting

The manufacturer recommends a single, level concrete mounting pad as shown in Figure 15. This method provides maximum stability for the generator set; however, draining the oil and servicing the generator set may require raising the set from the pad. Use an oil drain pump if clearance below the oil drain or extension is insufficient for a pan large enough to hold all the engine's oil.

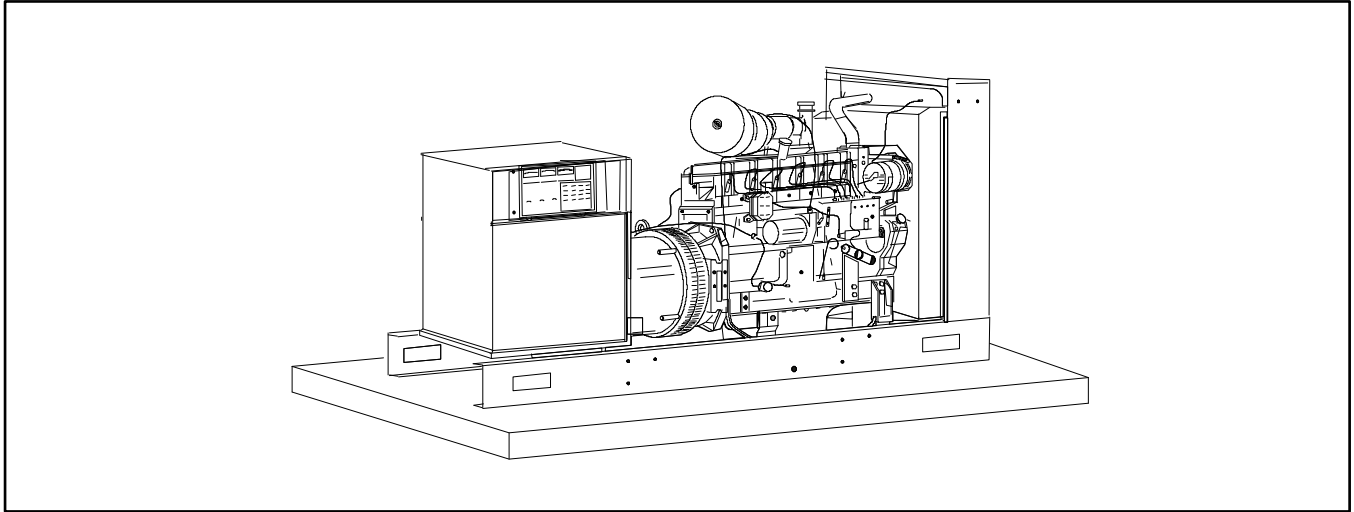

Figure 15 Single-Pad Mounting

3.2.2 Dual-Pad Mounting

The two-pad arrangement shown in Figure 16 provides easy access to conveniently drain the oil. Follow the oil draining considerations outlined in the previous section, Single-Pad Mounting.

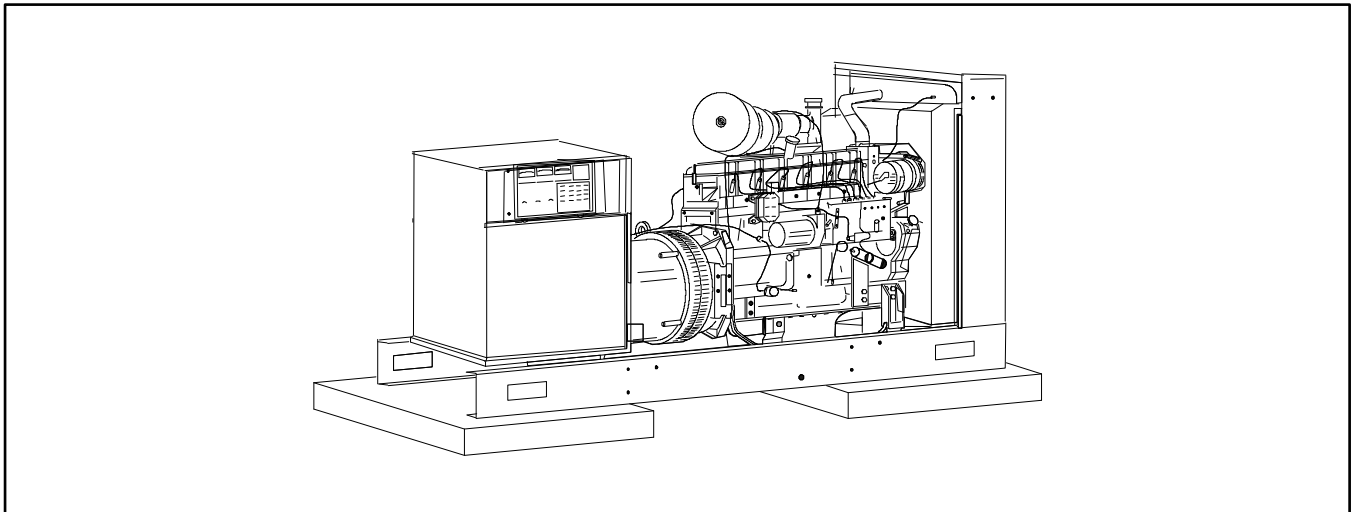

Figure 16 Dual-Pad Mounting

3.2.3 Four-Pad Mounting

The four-pad arrangement shown in Figure 17 provides more room under the engine for service than the previous two methods. Follow the oil draining considerations outlined in the previous section, Single-Pad Mounting.

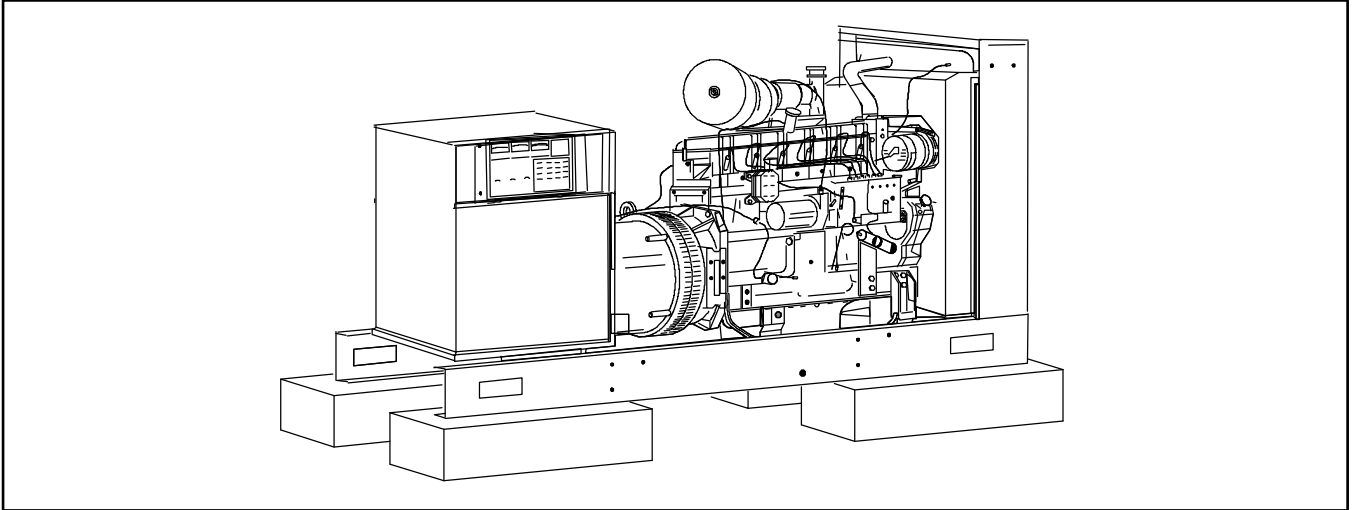

Figure 17 Four-Pad Mounting

3.2.4 Mounting Pad Specifications

Mounting pad weight.

The weight of the single mounting pad or combined weight of multiple mounting pads should equal or exceed the combined weight of the generator set and attached accessories.

To determine the weight of the mounting pad(s), determine the volume (length x width x height) of each pad in cubic meters (cubic feet). Multiply this result by 2400 kg/m³ (150 lb./ft.³) to determine a pad's weight. In multiple-pad installations, add the weights of all pads to determine the total mounting pad weight.

Mounting pad specifications.

Mounting pad composition should follow standard practice for the required loading. Typical specifications call for 17238-20685 kPa (2500-3000 psi) concrete reinforced with eight-gauge wire mesh or No. 6 reinforcing bars on 305 mm (12 in.) centers. The top surface of the mounting pad on which the generator set mounts should be within a flatness of 3 mm (1/8 in.).

The recommended concrete mixture by volume is 1:2:3 parts of cement, sand, and aggregate, respectively. Surround the pad with a 200-250 mm (8-10 in.) layer of sand or gravel for proper support and isolation of a pad located at or below grade.

Anchor the generator set to the concrete using bolts cast into the surface of the pad. Otherwise, drill holes in the mounting pad prior to generator set placement and use expansion anchor bolts. Anchor the generator set skid or fuel tank (if equipped) using all of the provided anchor holes on the bottom of the skid.

Note:

Refer to the generator set and accessory dimension drawings for conduit and fuel-line placement. The drawings give dimensions for electrical and fuel connection roughins and stubups including model specific clearances.

3.3 IBC Seismic Installation

International Building Code (IBC) seismic installations involve additional mounting and installation considerations. Refer to respective seismic installation ADV drawing(s) for seismic isolator requirements.

3.4 Vibration Isolation

Use one of the vibration isolation types detailed in the following paragraphs. Also, connections between the generator set or its skid and any conduits, fuel lines, or exhaust piping must include flexible sections to prevent breakage and to isolate vibration. These connections are detailed in subsequent sections.

Isolator types

The two primary types of isolators are neoprene and spring-type. Figure 18 shows neoprene isolators between the engine-generator and the skid, referred to as integral vibration isolation mounting. Integral vibration isolation units come from the factory with neoprene vibration isolation. Neoprene isolators provide 90% vibration isolation efficiency and are often sufficient for installations at or below grade.

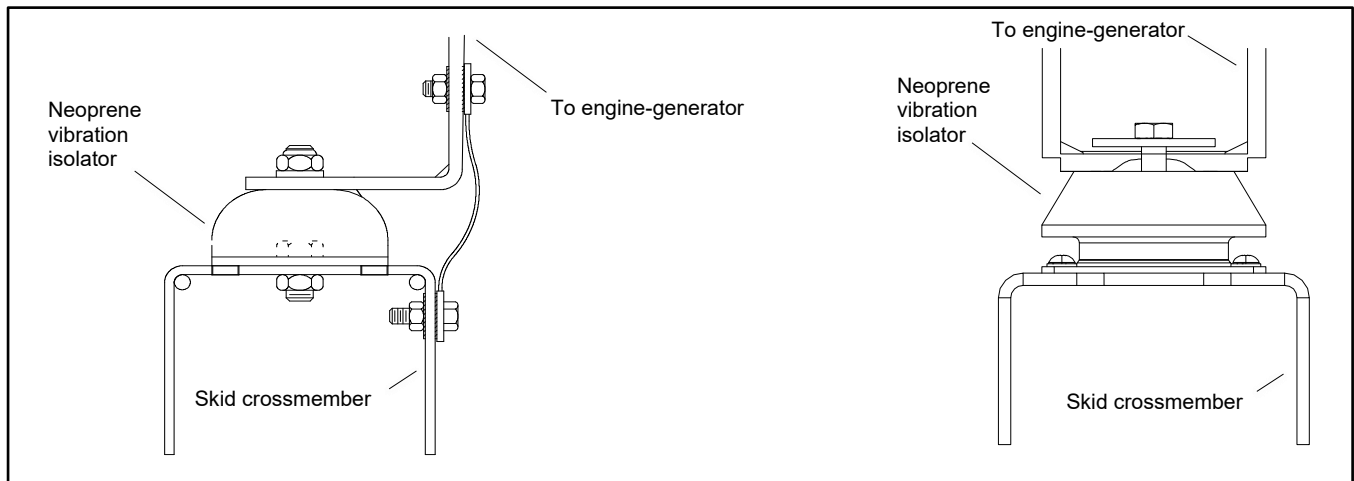

Figure 18 Neoprene-Type Integral Vibration Isolators

Figure 19 through Figure 23 shows the spring-type isolator kit installed with direct-mounted units. Direct-mounted units have no factory vibration isolation. Spring-type isolators provide 98% vibration efficiency and are recommended for above grade installations and other locations where vibration sensitivity could be an issue.

Generator sets with integral vibration isolation (neoprene isolators)

Skids for generator sets 20 kW and larger use I or C section-fabricated steel with a width of 52-76 mm (2-3 in.) per channel. The length varies with the size of the unit, resulting in a static load on the generator set skid of 69-72 kPa (10-25 psi) if the total bottom surface of the channel is in contact with the mounting pad.

Generator sets with direct mounting (spring-type isolators)

Larger generator sets typically mount directly to a structural steel base. For these units, install the recommended vibration isolators between the base and the mounting pad in the holes provided. Because of the reduced mounting surface area of these individual mounts, the static load on the mounting surface increases to the range of 345-690 kPa (50-100 psi).

Note:

Refer to the instructions supplied with the vibration isolator kits for more details.

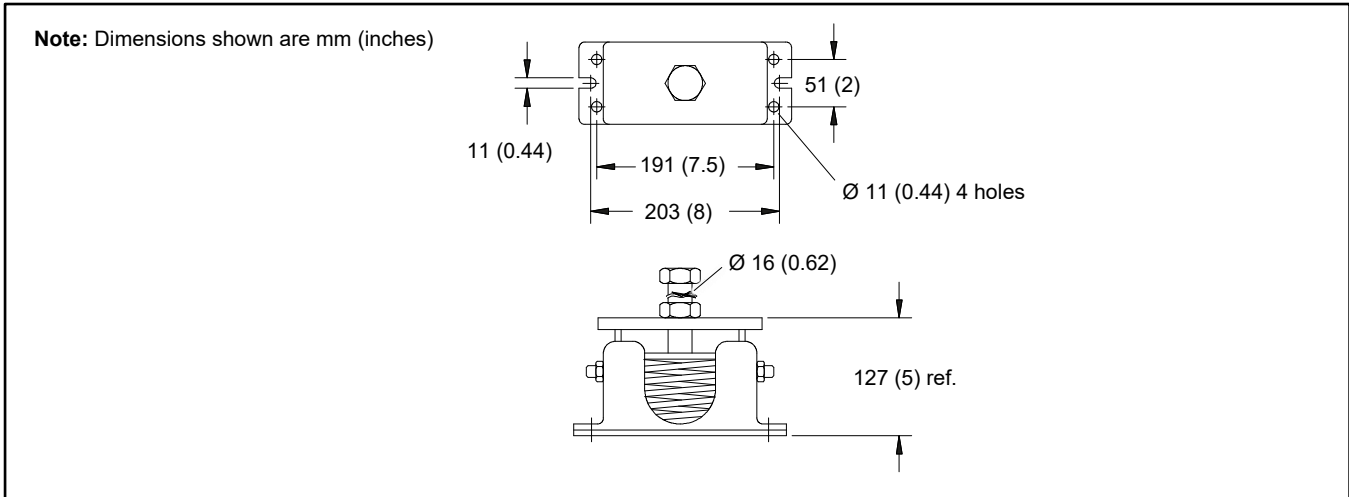

Figure 19 Vibration Isolators GM39515 and GM41122

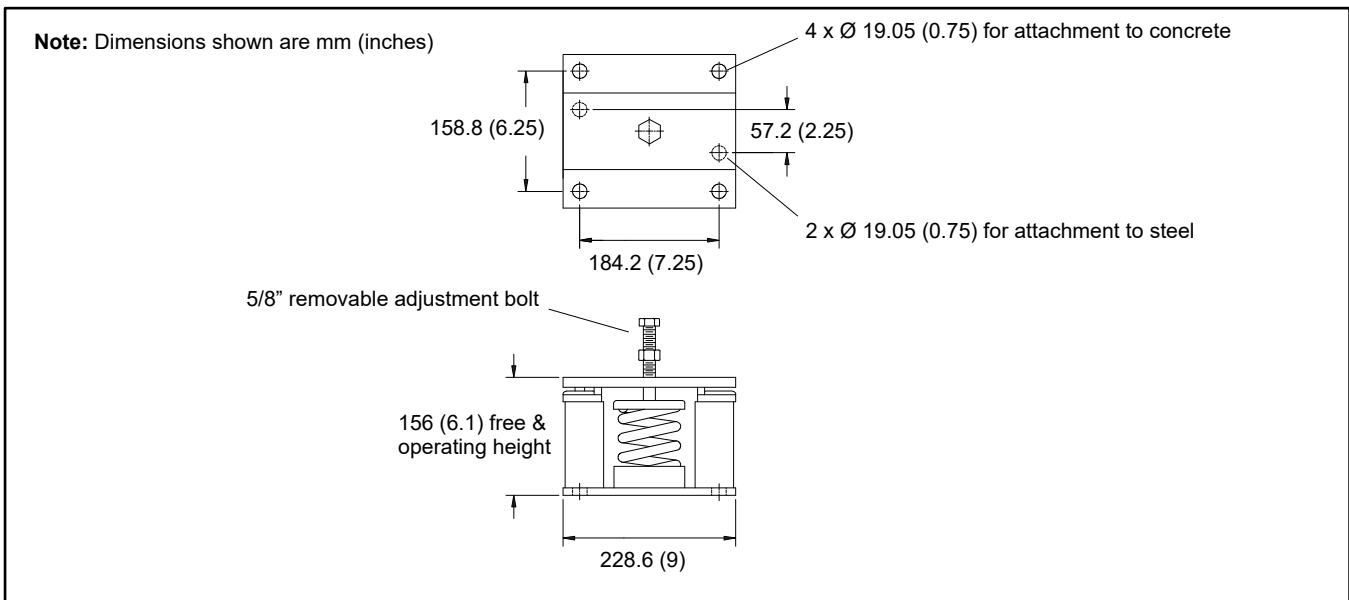

Figure 20 Vibration Isolators GM66019, GM66304 and GM76149

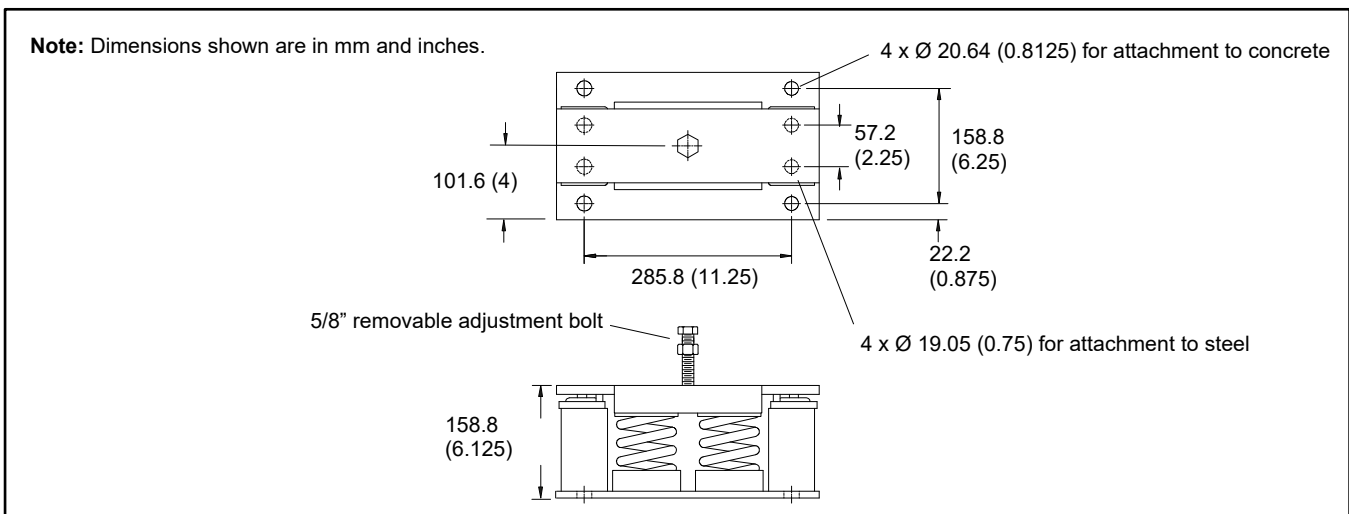

Figure 21 Vibration Isolators GM66020, GM66022, GM66023, GM66024, and GM66313

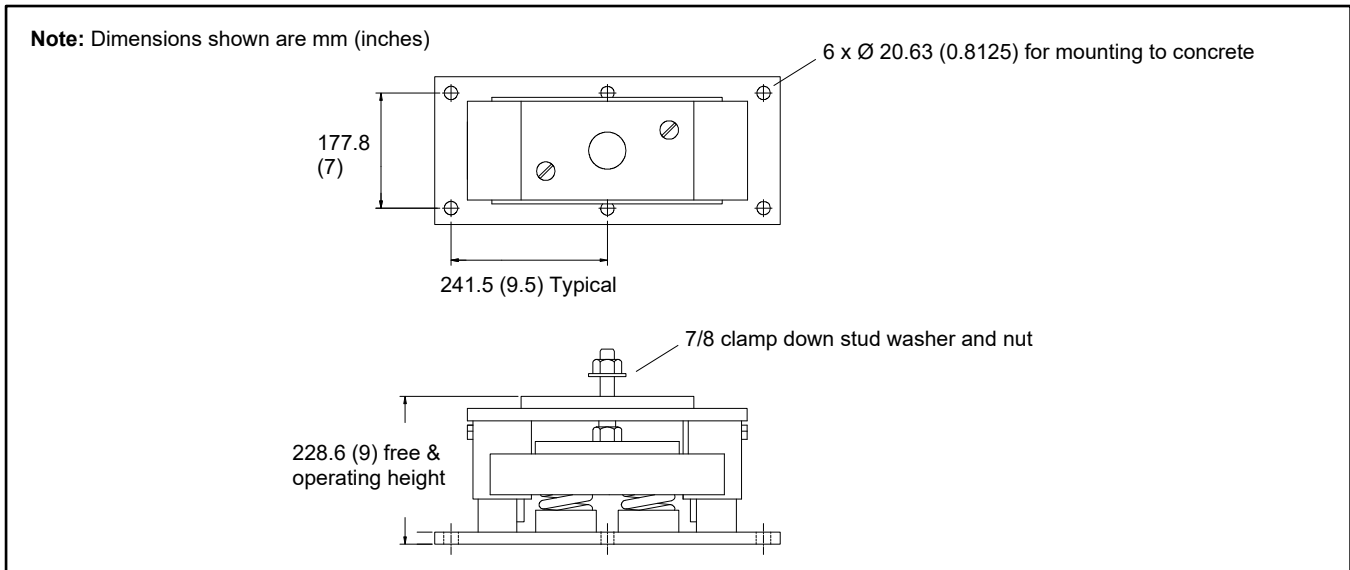

Figure 22 Vibration Isolator GM66025

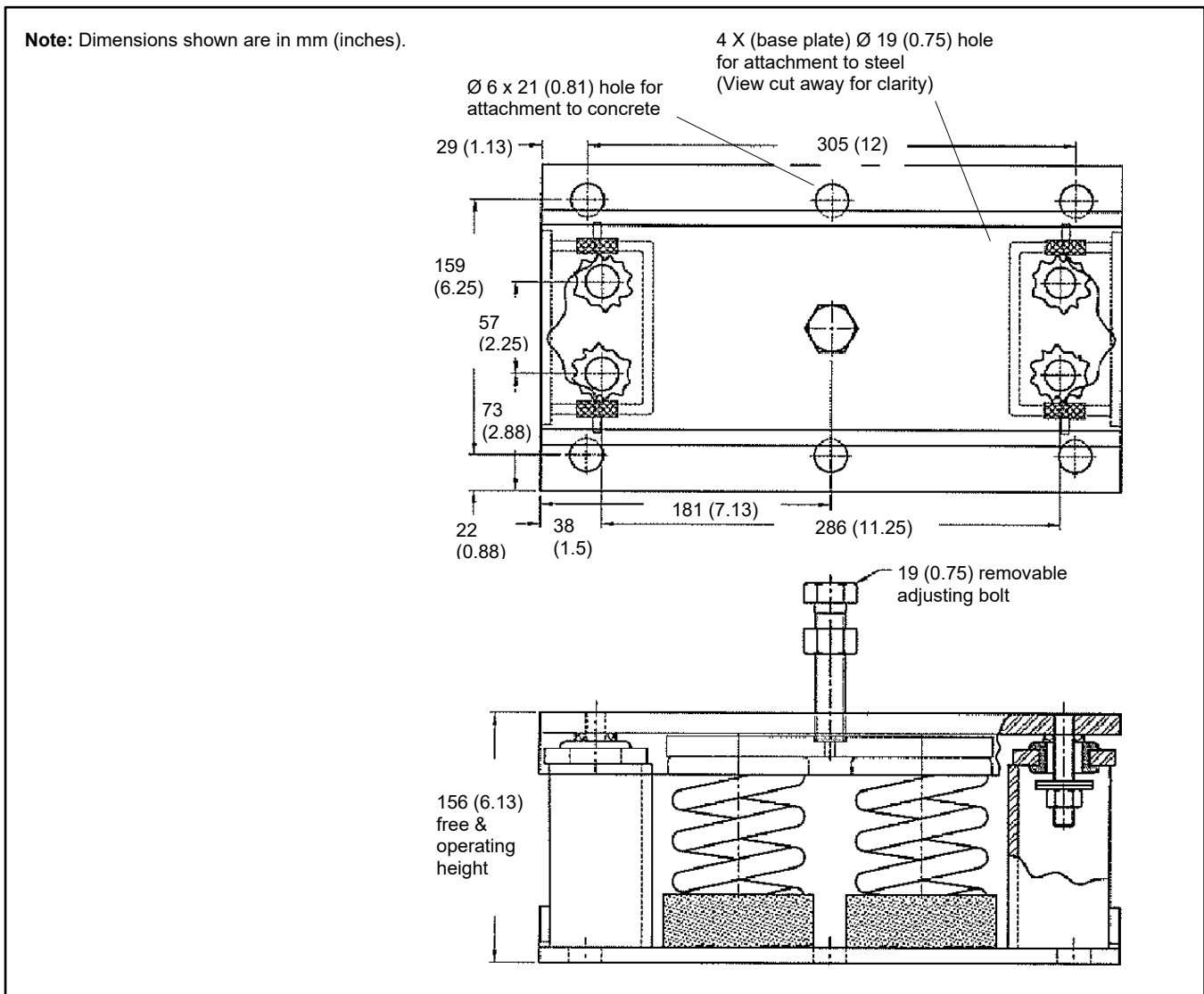

Figure 23 Vibration Isolator GM84038, GM84954, 11808000100, 11808000200, and 11808000300

Generator sets mounted on subbase fuel tanks

Do not install vibration spring isolators under the subbase fuel tank.

Dual isolation. For applications involving integral vibration isolators, installing additional isolators under the skid is not recommended, whether spring type, elastomeric, or otherwise. Additional isolation under the skid has the potential to produce dynamic motion of the skid that would otherwise be absent when the skid is anchored to the floor. Dynamic motion of the skid and its dynamic interaction with the generator dynamic motion has the potential to cause unit or component damage.

If dual isolation for an application is required:

- The structural engineer should consider high static deflection spring-type isolators installed under the skid that equal the number of elastomeric isolators, are in line front-to-back with the existing elastomeric isolators, and are supported by additional installed plates, as required. See Figure 24.
 - Spring isolators should achieve a static deflection of at least four times the static deflection of the integral isolators.
 - Typical elastomeric integral isolators have static deflections ranging from 0.125 in. to 0.5 in. As such, double isolation spring isolators placed under the skid should generally have a minimum static deflection of 2 in.
- The customer's structural engineer specifies the locations, performs calculations for static deflection, and verifies site performance of the spring isolators.

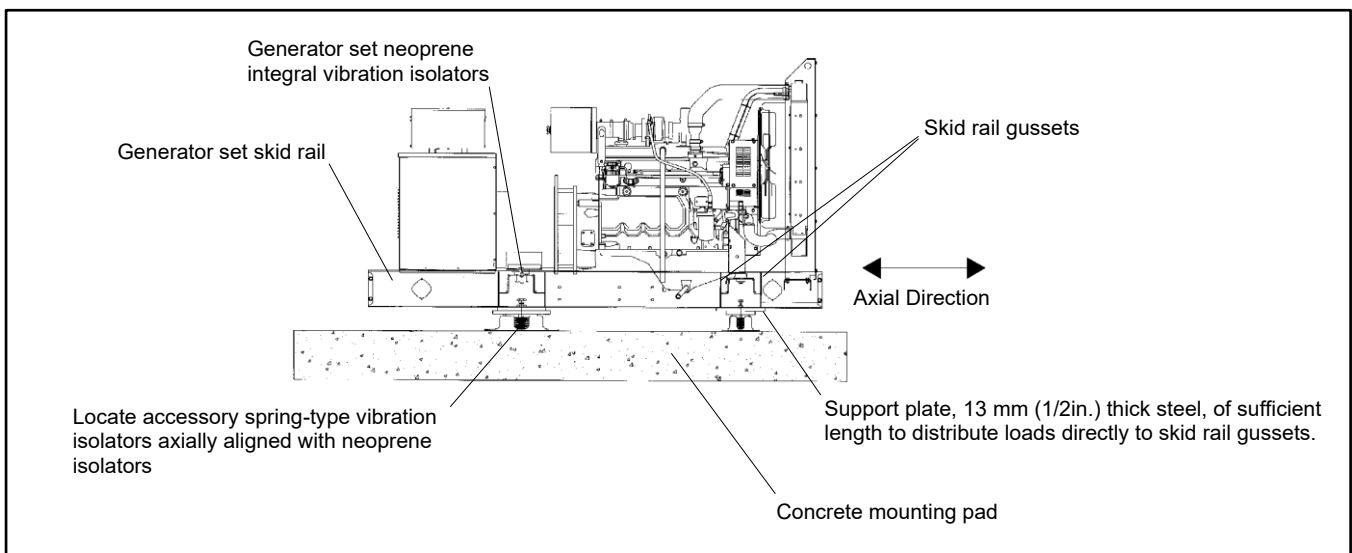

Figure 24 Accessory Vibration Mount Location

3.5 Dual-Bearing Alternator Alignment

Generator sets equipped with dual-bearing alternators require alignment after mounting the generator set skid to a mounting pad. Refer to Service Bulletin SB-566 for details.

4.1 General

Combustion and heat dissipation require an ample flow of clean, cool air regardless of whether the generator set is air- or liquid-cooled. Approximately 70% of the heat value of fuel consumed by an engine is lost through the cooling and exhaust systems.

Battery compartment ventilation.

To prevent the accumulation of explosive gases, ventilate compartments containing batteries.

4.2 Air-Cooled Engines

Refer to the generator set specification sheet for air requirements. Generally, airflow requirements do not present a problem since air-cooled models are designed for outside installation.

When planning outside installation, consider how buildings and landscaping affect airflow. Also consider seasonal changes such as snow or foliage accumulation and potential flooding conditions. Follow a regular maintenance routine to remove snow and foliage accumulations.

4.3 Liquid-Cooled Engines

4.3.1 System Features

Generator sets designed for interior installation feature liquid cooling systems. The three most common liquid cooling systems are unit-mounted radiator, remote radiator, and city-water cooling. Observe the common installation considerations outlined below as well as the installation considerations for your generator set's cooling system as detailed in subsequent sections.

4.3.2 Installation Considerations

Intake and outlet openings

Provide air intake and air outlet openings for generator sets located in a building or enclosure. Keep air inlets and outlets clean and unobstructed. Position the air inlet into the prevailing wind and the air outlet in the opposite direction. The recommended airflow path should flow over the engine and generator set, passing over the alternator first and then the engine.

Elevated outdoor installations

If the generator set enclosure is mounted on multiple pads, in cases where a single pad is not practical such as an uneven building roof, it may cause discharge air recirculation under the unit. Enclosures are constructed with the intent of single pad mounting where the unit is sealed to prevent discharge air recirculation. If multiple pad installation is unavoidable, use a single pad above the multiple pads and fabricate flashing/skirting around the multiple pads to minimize unwanted discharge air recirculation.

Ventilating fans

Some buildings tend to restrict airflow and may cause generator set overheating. Use ventilating fans and/or ductwork to increase airflow in the building if the generator set's cooling fan does not provide adequate cooling. See Figure 25. Remote radiator and city-water cooled models require ventilating fans. When using ductwork and ventilating fans, check the exhaust fan capacity in m³/min. (cfm). If using exhaust fans, install fan-operated louvers with exhaust fans to regulate airflow. Follow the fan manufacturer's recommendations to determine the size of the inlet and outlet openings.

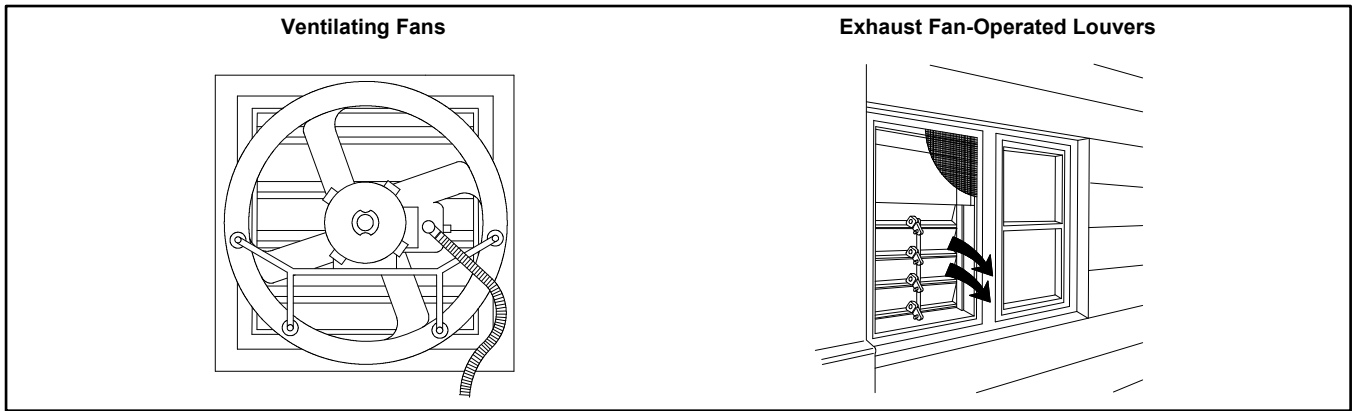

Figure 25 Ventilating Fan and Exhaust Fan-Operated Louvers

Thermostatically-controlled louvers

Do not allow uncontrolled recirculation of air within an enclosure. The ventilation system must provide a temperature differential sufficient to prevent high engine temperature shutdown on even the hottest days.

In areas of great temperature variation, install movable louvers to thermostatically regulate airflow and room temperature. See Figure 26. In the following subsection, Unit-Mounted Radiator Cooling, refer to “Louver use” under Installation Considerations for further information.

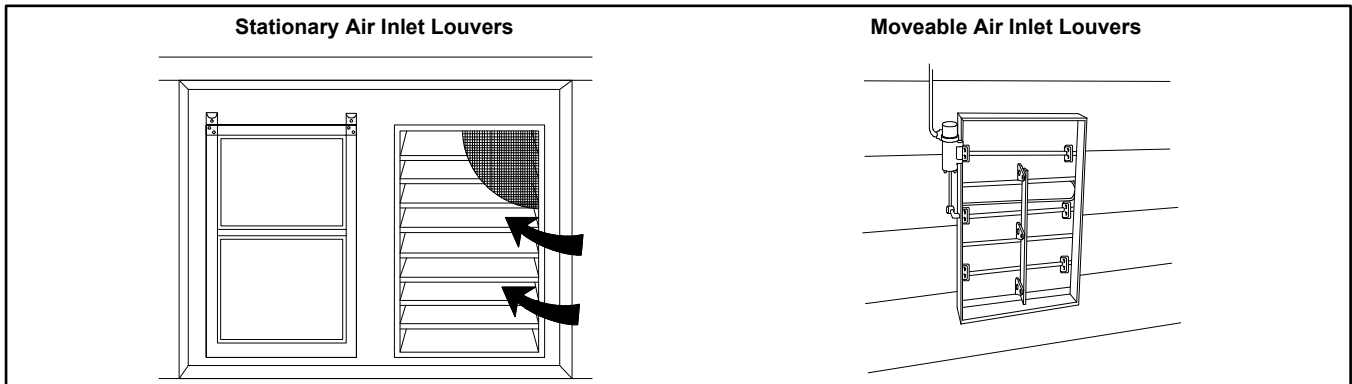

Figure 26 Stationary Air Inlet Louvers and Moveable Air Inlet Louvers

In cold climate interior installations using controlled recirculation to recover heat, install thermostatically activated louvers and fans to prevent the generator set and engine room from overheating.

Electric louvers are usually connected to the optional generator set run relay. Typically, the louvers are energized to open when the generator set is operating. However, some louvers are energized to close and when deenergized are spring-actuated to open when the generator set is operating.

Filters

Install a furnace-type or similar filter in the inlet opening if the generator set operates in an atmosphere highly contaminated with impurities such as dust and chaff.

Air restrictions

When using a filter, screen, or other air restriction, increase the inlet opening size by the following amounts as a general principle to compensate for diminished airflow:

- Louvers: Enlarge the opening 50%.
- Window screening: Enlarge the opening 80%.
- Furnace-type filters: Enlarge the opening 120%.

Engines have maximum air intake restrictions. Refer to the respective generator set specification sheet for specific requirements.

4.3.3 Recommended Coolant

All applications require antifreeze/coolant protection. Add antifreeze/coolant before starting the generator set or energizing the block heater(s). Most diesel engine manufacturers require the use of an inhibitor additive to the antifreeze/coolant.

Use a proper mixture of glycol (ethylene, propylene, or extended life organic acid), water, and supplemental coolant additive (SCA) based on the engine manufacturer's recommendations. The antifreeze/coolant and additive mixture reduces corrosion, sludge formation, and cavitation erosion and provides boil and freeze protection.

Refer to the engine manufacturer's operation manual for engine antifreeze/coolant specifications, concentration levels, and inhibitor selection recommendations.

4.4 Unit-Mounted Radiator Cooling

The unit-mounted radiator is the most common cooling system for engine-driven generator sets.

4.4.1 System Features

The system's major components include an engine-driven fan and circulating water pump, a radiator, and a thermostat. The pump circulates water through the engine until it reaches operating temperature. Then the engine thermostat opens, allowing water circulation through the radiator. The thermostat restricts water flow as necessary to prevent overcooling. The fan blows air from the engine side of the radiator across the cooling surface.

4.4.2 Installation Considerations

Figure 27 shows a typical unit-mounted radiator installation. Note the direction of airflow and refer to the figure as needed during installation.

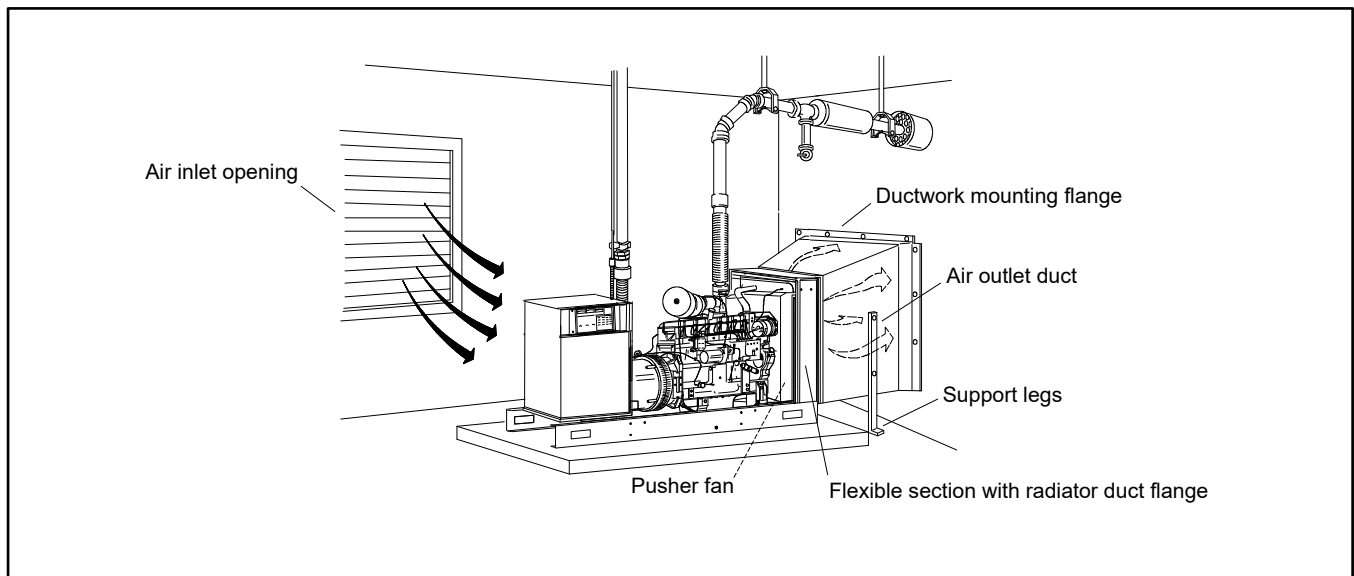

Figure 27 Radiator-Cooled Generator Set Installation

Avoid suction fan use.

The alternator airflow should move in the same direction as the engine's standard pusher fan. Using a suction fan to reverse airflow is not recommended because it may interfere with the alternator cooling airflow. This in turn reduces the maximum engine power available because higher temperature combustion air is drawn into the air cleaner.

Use ductwork to direct airflow.

Direct the radiator air outside the room or enclosure using sheet metal ductwork with structural supports. Keep ductwork as short, straight, and unobstructed as possible. Combined static pressure restrictions greater than 0.12 kPa (0.5 in. water column) on the radiator inlet and outlet openings cause reduced airflow and contribute to overheating especially in high ambient air.

temperatures. Use heavy canvas, silicone rubber, or similar flexible material for the connection between the radiator duct flange and the ductwork to reduce noise and vibration transmission.

Outlet and inlet location and sizing.

Consult TIB-118 for cooling system capability and size the intake and discharge louver to correlate to the desired room restriction. If the pressure drop is not available, size the outlet duct area to 1.5 times the radiator duct flange area or larger and the inlet air opening to 2.0 times the radiator duct flange area or larger.

If screens, louvers, or filters are used on either the inlet or outlet, increase the inlet or outlet size according to the recommendations given in the previous section on Installation Considerations.

Since the exhaust air of larger units is both high volume and high velocity, direct the exhaust flow away from areas occupied by people or animals.

Louver use.

Design temperature-controlling louvers to prevent air inlet restrictions and air pressure reductions inside the building. Low building pressure can extinguish pilot lights on gas-fired appliances or cause problems with the building ventilation system.

Additionally, bringing large quantities of winter air into a building wastes building heat and risks frozen water pipes in normally heated spaces. Use dampers and controlled air outlet louvers as shown in Figure 28 to eliminate these problems and allow recovery of engine heat to reduce building heat loss. Close the louvers to the exterior and open the interior louvers when the outdoor temperature is below 18°C–21°C (65°F–70°F). Reverse the louver settings when the outdoor temperature is above 21°C–24°C (70°F–75°F).

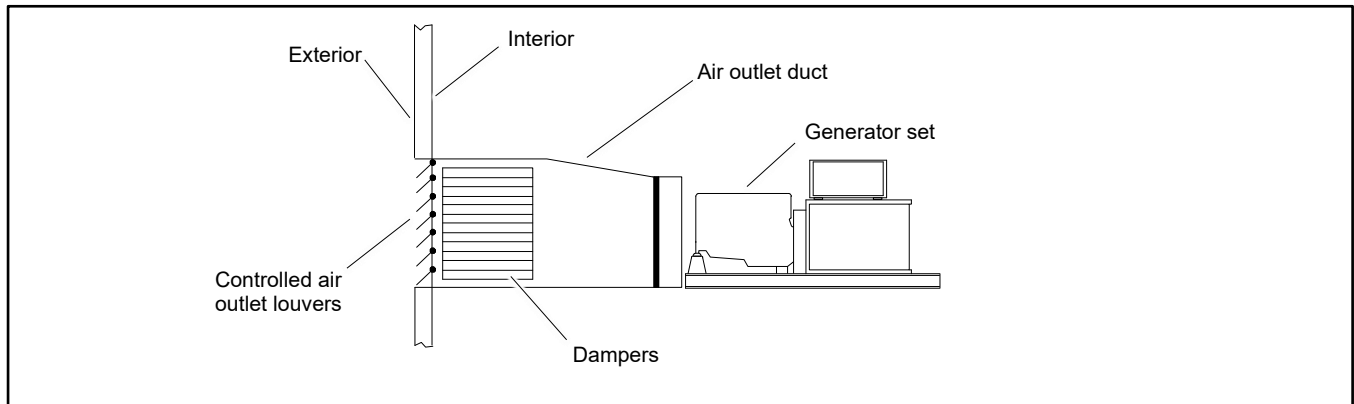

Figure 28 Air Control Louvers

4.5 Remote Radiator Cooling

A remote radiator system allows installation of generator sets in locations where it would otherwise be difficult to bring the volume of air required to cool a unit-mounted radiator. In these systems, the engine water pump pushes coolant through a radiator mounted remotely from the generator set and, typically, in an open area. An electric motor-driven fan mounted on the radiator circulates air across the radiator's cooling fins.

The remote radiators have a Secondary Expansion Deaeration and Drawdown (SEDD) tank. This SEDD tank can be connected to the radiator either as an open or closed tank system. Closed SEDD tanks are typically used when the remote radiator is in close proximity to the generator set and open SEDD tanks are typically used when the remote radiator is located further away.

In order to assess a remote radiator cooling system, the cooling system designer needs the following data.

From the respective generator set specification sheet, obtain the:

- Engine jacket water flow, Lpm (gpm)
- Cooling air required for generator set based on 14°C (25°F) rise and an ambient temperature of 29°C (85°F), m³/min. (cfm)
- Maximum static (vertical) head allowable above engine, kPa (ft. H₂O)
- Heat rejection to coolant

From the engine and/or radiator data sheet, obtain the:

- Maximum water pump inlet restriction kPa (psi)
- Maximum allowable coolant pressure differential external to engine kPa (psi)
- Maximum top tank temperature

4.5.1 General

System limitations.

Cooling systems are limited by radiator cap ratings. The maximum radiator operating pressure is 138 kPa (20 psi) and the maximum operating temperature is 121°C (250°F). Radiators are available for vertical or horizontal discharge. See Figure 29 and Figure 30.

Air requirements.

Refer to the generator set specification sheet for radiator air and engine/alternator air requirements. Cooling air required for generator sets equipped with a remote radiator is based on a 14°C (25°F) rise and an ambient temperature of 29°C (85°F). The amount of air required to ventilate the generator set room or enclosure determines the size of the air inlet and outlet. Configure the ventilation air inlet and outlet so that air flows across the generator set.

Use a ventilating fan, if necessary, to dissipate alternator and engine heat loss.

Note:

All remote radiators are sized for mounting in an open area with no additional external devices attached. Attached devices, confined installation, louvers, dampers, ductwork, or other inlet or outlet air restriction require resizing the radiator to compensate for reduced airflow.

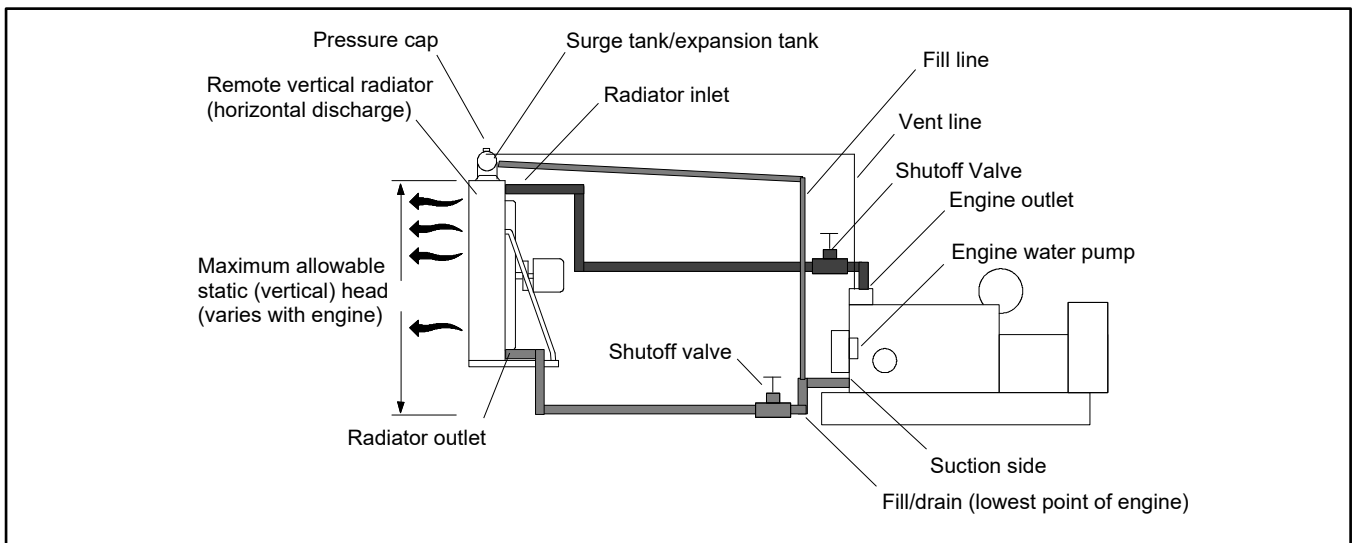

Figure 29 Remote Vertical Radiator (Horizontal Discharge) System

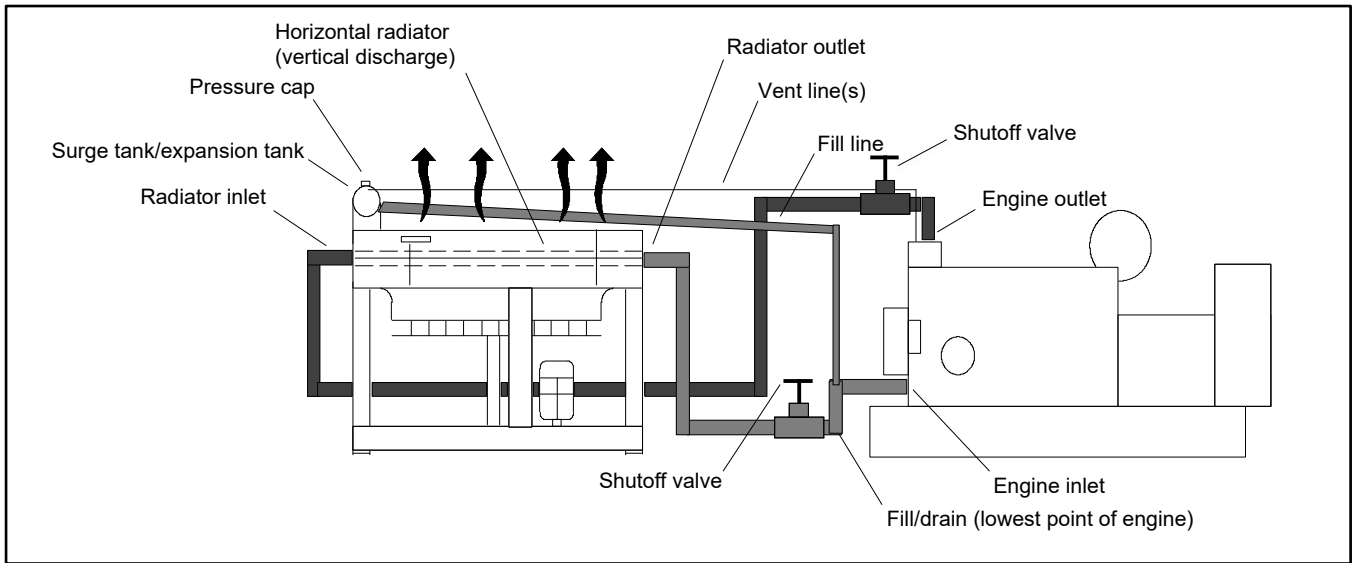

Figure 30 Remote Horizontal Radiator (Vertical Discharge) System

Static (vertical) head.

If the vertical distance from the engine water pump to the radiator (known as static head) is within the engine manufacturer's recommendations, and the pressure drop through the piping and remote radiator does not exceed the engine manufacturer's limits, use the engine water pump to circulate water through the remote radiator. The allowable static head ranges from 5.2 m-15.2 m (17 ft.-50 ft.) and is listed on the generator set specification sheet. Exceeding the allowable static head causes excessive pressure on engine components resulting in problems such as leaking water pump seals.

Note:

Size the pressure relief valve or cap to remain under the engine pressure limit.

Hot well tank/heat exchanger.

When the static (vertical) head exceeds the distance stated in the specification sheet, use a hot well tank or heat exchanger and auxiliary circulating pump as shown in the following section, Vent Lines. Always wire the circulating pump in parallel with the remote radiator fan so that both operate whenever the generator set operates.

A partial baffle divides a hot well tank into two or more compartments. The engine pump forces heated water into the hot side, and the auxiliary pump then draws the water off and forces it into the radiator. After circulating through the radiator, coolant drains back to the cold side of the well where the engine water pump removes it. A hot well or heat exchanger also isolates head pressures from the engine.

Note:

The water in the hot well tank drains into the radiator when the generator set is not running.

Note:

Determine the size requirements of the remote radiator and hot well tank/heat exchanger for each application. Do not use a standard remote radiator with a hot well tank/heat exchanger.

4.5.2 Vent Lines

Route the vent lines at a continuous upward slope from the engine connection exit to the expansion tank. Port all vent lines individually into the expansion tank above the coolant level.

Locate the vent lines in the expansion tank to prevent splash on the coolant level sensor. Thoroughly vent the systems by installing vent lines to all the vent points on the engine and the charge air cooler circuits including the radiator core. Refer to the installation drawings for vent points.

Size the vent line the same as the connection point on the engine. The vent lines may be slightly larger; however, vent lines sized too large will increase fill line flow and possibly reduce head pressure applied to the engine water pump inlets.

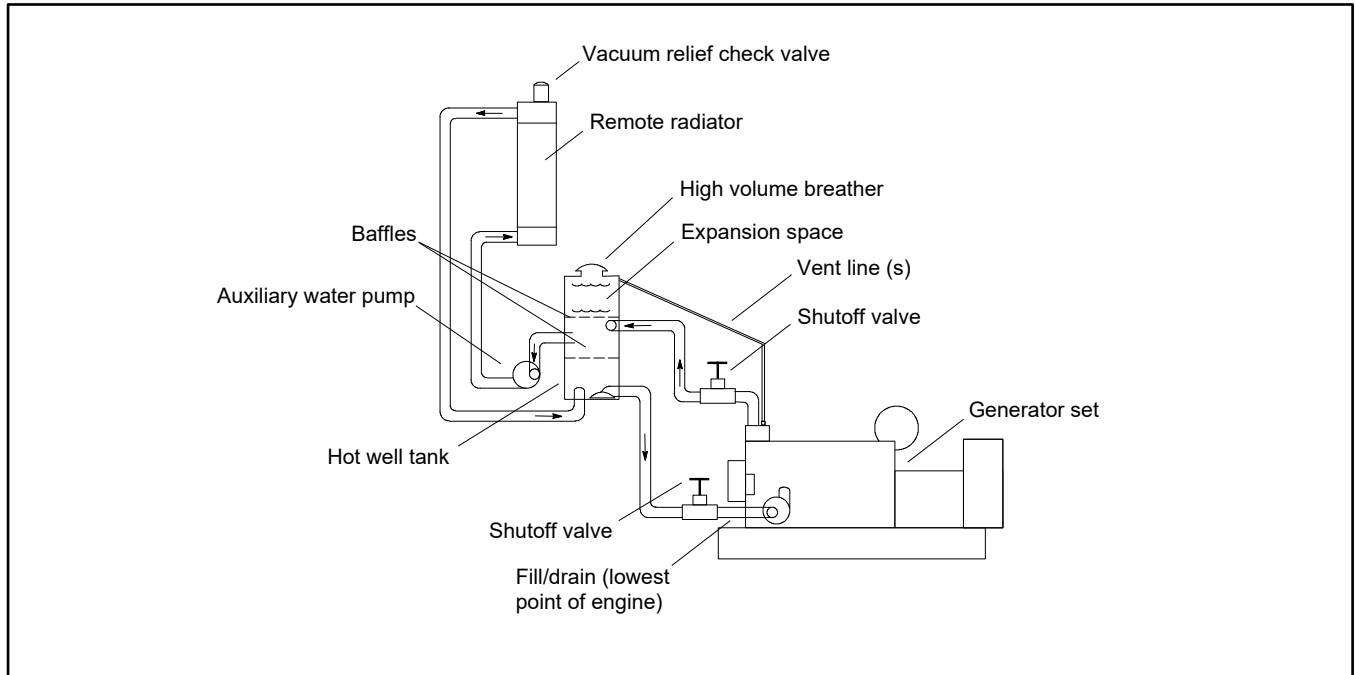

Figure 31 Compound Remote Radiator/Hot Well Tank Cooling System

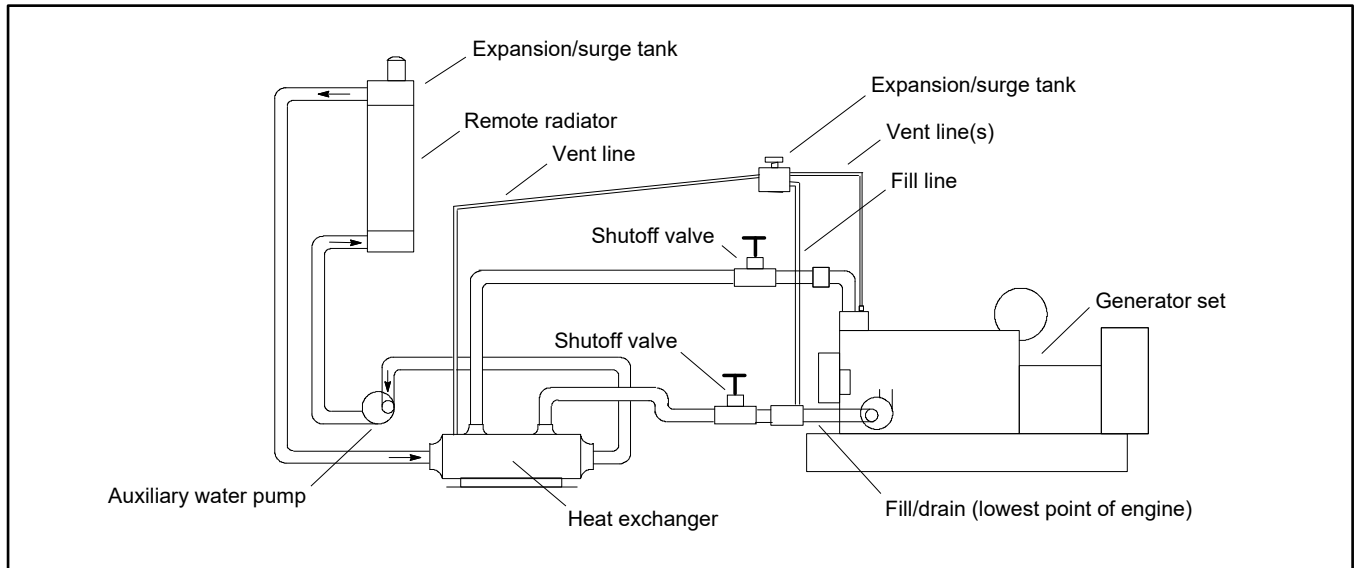

Figure 32 Compound Remote Radiator/Heat Exchanger Cooling System

4.5.3 Fill Lines (Balance or Static)

Connect the fill line(s) to the bottom of the expansion tank. Make the lines as short as possible, continuously descending, and connected directly before the engine water pump(s). To provide a positive head pressure to the engine water pump inlet, properly locate the fill line (or makeup line). See the installation drawings for the fill line connection points.

Connect the vent and fill lines to the expansion tank at the greatest possible distance from each other to prevent aeration and preheating of the coolant returning down the fill line.

The minimum fill line sizes cannot be smaller than the connection point on the engine. Do not allow fittings on the fill lines to reduce the effective size. If other cooling system components vent too much coolant to the expansion tank, larger diameter fill lines may be needed.

4.5.4 Location Considerations

When choosing the radiator's location:

- For economical installation and operation, locate the radiator as close as practical to the engine and at the same elevation to reduce piping, coolant, and wiring costs.
- Locate the radiator surge tank fill opening and vent line(s) at the highest point in the cooling system.
- Position the radiator no closer than one fan diameter from a wall, another radiator, or any other obstruction that would restrict air movement and future service access.
- Locate the radiator to prevent recirculation of the heated exhaust air back into the intake stream.
- Mount the radiator in an area where prevailing winds do not hamper free airflow.
- Locate the radiator where it is not subject to deep snow or ice accumulation, flooding, industrial fallout, leaf accumulation, heavy dust and chaff, or other detrimental seasonal or environmental conditions.
- For rooftop installations, do not locate the radiator near critical sound areas, building ventilation, or hood exhausts.

4.5.5 Installation Considerations

When installing the remote radiator:

- Use a remote radiator setup kit, if available, to aid installation. See Figure 33.
- Wire the cooling fan motor to the generator set output so that the fan operates whenever the generator set operates. There is no need for a thermostatic control of the fan motor because the engine thermostat prevents overcooling as it does on generator-set-mounted radiator systems unless noise and power consumption reduction dictate the need. Follow all applicable national and local codes when wiring the cooling fan.
- Follow the wiring diagram on the remote radiator's fan motor. The motor rotation must match the fan blade design. The manufacturer supplies most units with counterclockwise fan rotation as viewed from motor side. The fan is typically a blower type, moving air from the fan side of the radiator, through the core, and out the front side.
- Preferably, connect no devices to either side of the radiator. Resize the radiator if adding louvers or duct work to the radiator to compensate for reduced airflow.
- Ensure that the radiator is level and securely bolted to a firm, solid foundation.
- Brace the radiator as needed, especially in areas with strong winds.
- Use isolators to keep area vibration from affecting the radiator or to keep vibration produced by the radiator from affecting surrounding areas.
- Use hose clamps on all non-threaded connections.

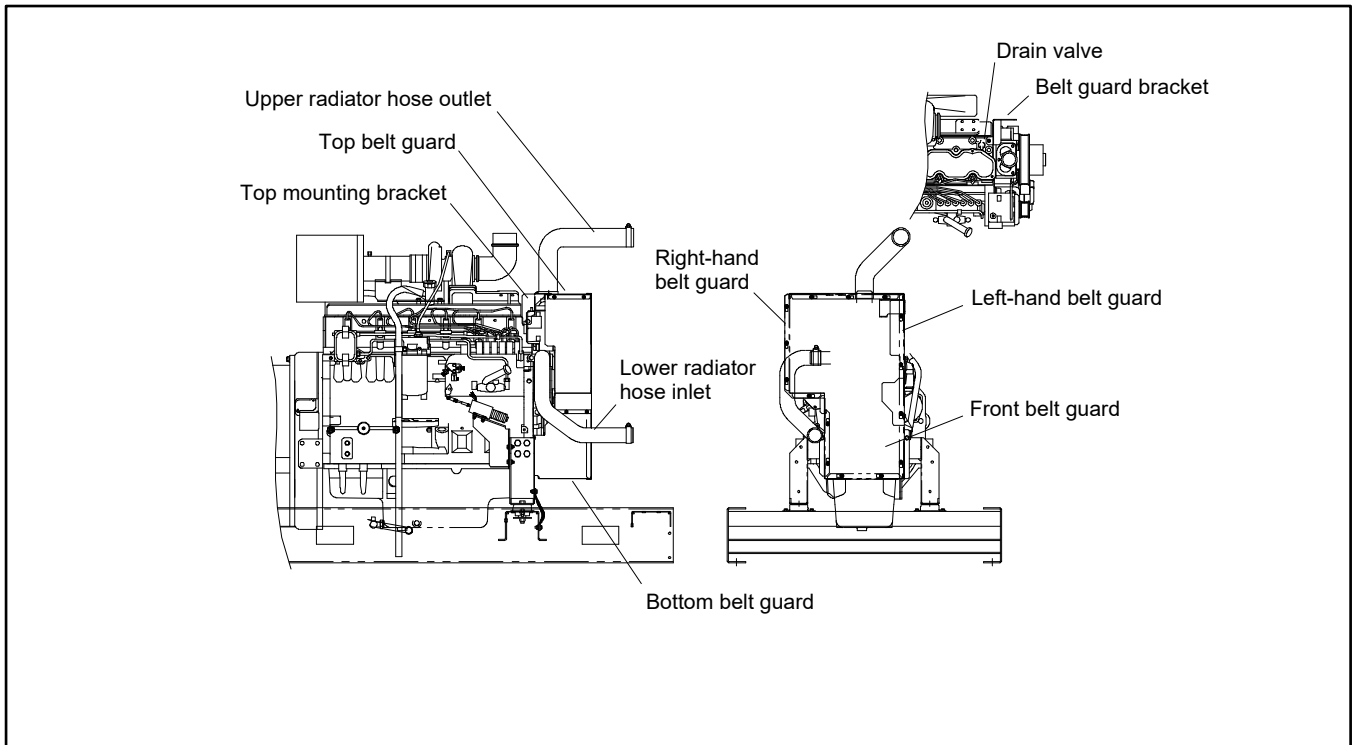

Figure 33 Remote Radiator Setup Kit, Typical

4.5.6 Surge (Expansion) Tank for Horizontal Discharge Radiator

A horizontal discharge remote radiator requires the use of a surge (expansion) tank. Locate the tank at the highest point in the cooling system. The surge tank provides venting, surge/ expansion protection, and filling/makeup functions.

- The cooling system top tank should be designed to include a drawdown volume of 5-8%, a deaeration volume greater than 10% and an expansion volume that is typically 8-10% of the system volume (thus a typical top tank is ~25% of the total system volume). See Figure 34.

Drawdown Volume	Typical 5-8%
Deaeration Volume	Typical >10%
Expansion Volume	Typical 8-10% fluid
Total Tank	Approximately 25% total system volume

Figure 34 Recommended Cooling System Top Tank Sizing

- Locate the coolant level sender at a height that is above the drawdown level so the coolant level sender activates before air is ingested into the coolant.
- Locate the coolant level sender in a location where there is minimal agitation to prevent splashing on the coolant level sender.
- Equip the surge tank with a sight-glass gauge, overflow tube, and pressure cap.
- Connect the main line from the surge tank to the highest point of the remote radiator. Most vertical core radiators have the surge tank as part of the radiator top tank. The setup illustrated in the previous figure provides for radiator and engine deaeration and a positive pressure at the pump suction inlet.
- Use a strainer to filter dirt, scale, and core sand from the coolant line.

Piping

Size water piping between the engine and the remote radiator large enough to eliminate the need for a booster pump. If the cooling system requires a booster pump, contact your distributor/dealer.

Use piping of ample size and with as few short sweep bends or elbows, tees, and couplings as possible. Use long sweep elbows or long bends, if bends are required.

Installation

Support piping externally, not from the radiator or engine.

On standard remote radiators, connect radiator bottom outlets only to the suction side of the pump. Plumb the lines to prevent air from becoming trapped in the lines. Route piping in one general direction, either upward or downward. A combination of both upward and downward piping creates air pockets in the piping. Route vent lines to the expansion/surge tank without creating low spots in the lines.

Flexible connections

Provide flexible connections when connecting piping to the radiator assembly. Use hose clamps at all non-threaded connections.

Shutoff valves

Locate shutoff valves between the engine and cooling system to allow for isolation of both the radiator and the engine. A shutoff valve eliminates the need to drain the entire cooling system during service.

4.5.7 Procedure to Fill with Deaeration

For radiators designed for full deaeration, fill the radiator according to the following procedure.

1. Fill the cooling system from the bottom when possible. Otherwise, fill the radiator at the filler neck.
2. Next, fill the radiator through one of the top tank or expansion/surge tank inlets located before the final hose connection.
3. Continue filling the system to cover the filler neck bottom until coolant appears in the sight glass located in the radiator top tank.
4. Check and correct any leaks in the system.
5. After initial startup, check coolant levels and add coolant as necessary.

4.5.8 Procedure to Fill without Deaeration

For radiators designed without deaeration, fill the radiator according to the following procedure.

1. Initially, fill the radiator through one of the top tank inlets located before the final hose connection for faster and more complete fillup.
2. Fill the cooling system from the bottom when possible. Otherwise, fill the radiator at the filler neck with coolant covering the filler neck bottom until coolant appears in the sight glass located in the radiator top tank.
3. Check for and correct any leaks in the system.
4. After initial startup, check coolant levels and add coolant as necessary.

4.5.9 Checks after Initial Startup

If any problems arise during startup, immediately shut down the generator set. See Figure 35, Cooling System Checklist. Even after a successful startup, shut down the generator set after 5-10 minutes and recheck the belt tension to make sure no hardware has loosened during operation. Perform another recheck after 8-12 hours of operation.

√	Operation
	Verify the cooling fan's position in the fan shroud.
	Check the mounting hardware.
	Check the fan motor for free rotation.
	Check V-belts for alignment and tension.
	Fill the system with coolant and check all connections for tightness and leaks.
	Verify that all electrical connections are secure and that the power source matches the motor nameplate.
	Verify that no loose foreign material is in the fan's air
	With the unit running, check for:
	fan clearance
	excessive vibration
	excessive noise
	coolant leaks

Figure 35 Cooling System Checklist

4.6 City Water Cooling

4.6.1 System Features

City water-cooling systems use city water and a heat exchanger for cooling. They are similar to remote radiator systems because they require less cooling air within the generator set room than unit-mounted radiator systems. Figure 36 shows some of the elements of a typical installation.

The heat exchanger limits the adverse effects of city water chemistry to one side of a heat exchanger, which is relatively easy to clean or replace, while engine coolant circulates in a closed system similar to the radiator system. The heat exchanger allows engine temperature control, permits the use of antifreeze and coolant conditioners, and is suited to the use of an engine block heater as a starting aid.

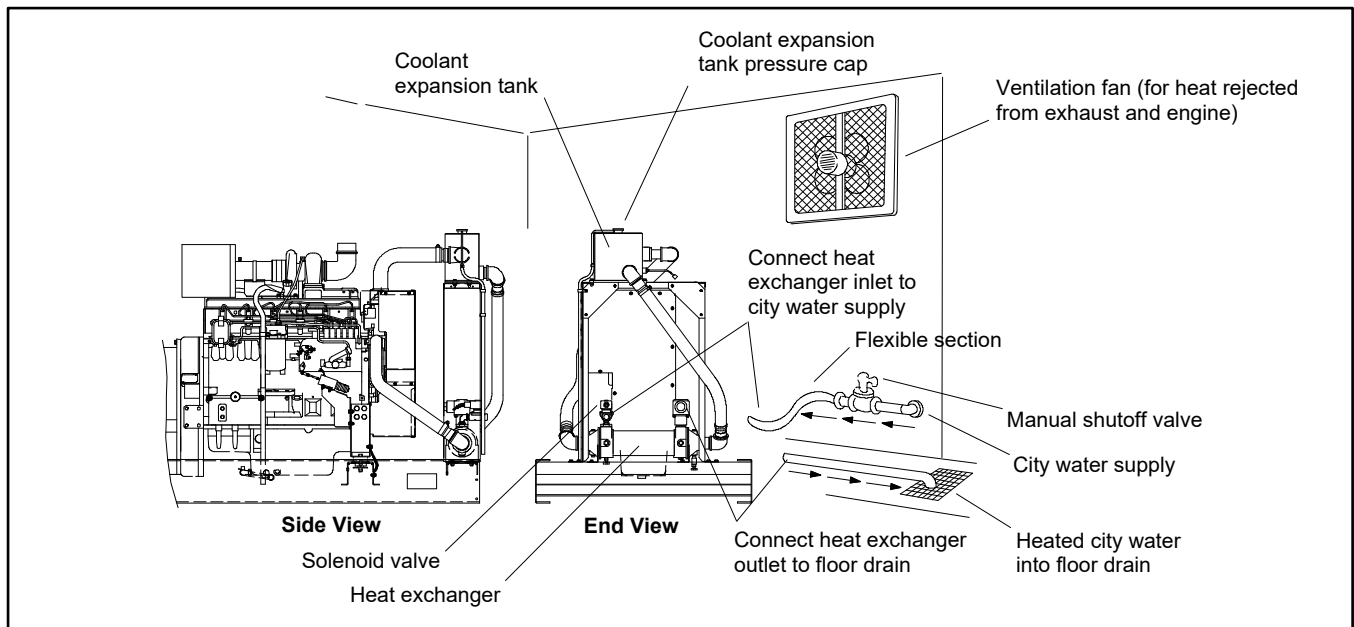

Figure 36 City-Water Cooling System with Heat Exchanger

4.6.2 Installation Considerations

Vibration isolation requirements

Water inlet and outlet connections are mounted on the generator set skid and isolated from engine vibration by flexible sections. If the generator set is vibration-mounted to the skid and the skid is bolted directly to the mounting base, no additional flexible sections are needed between connection points on the skid and city water lines. If the generator set skid is mounted to the base with vibration isolators, use flexible sections between the connection points on the skid and city water lines.

Shutoff valve location

A solenoid valve mounted at the inlet connection point automatically opens when the generator set starts, providing the engine cooling system with pressurized water from city water mains. This valve automatically closes when the unit shuts down. Use an additional customer-supplied valve ahead of the entire system to manually shut off city water for generator set service.

4.7 Cooling Tower

A cooling tower system is a variation of a city water cooling with heat exchanger system. In warm, dry climates, a cooling tower is a suitable source of generator set cooling water.

A cooling tower system consists of the engine cooling system plus a raw-water system. The engine cooling system usually includes the engine water pump, a heat exchanger, a surge tank, and the engine water jacket. The raw-water system consists of the cooling tower, a raw-water pump, and the tube portion of the heat exchanger. A typical system is shown in Figure 37.

The engine cooling system circulates coolant through the heat exchanger outer shell. Raw water circulates through the heat exchanger tubes absorbing heat from the engine coolant. The heated raw water flows into a pipe at the top of the cooling tower and sprays down into the tower to cool by evaporation. Because some water is constantly being lost through evaporation, the system must provide makeup water.

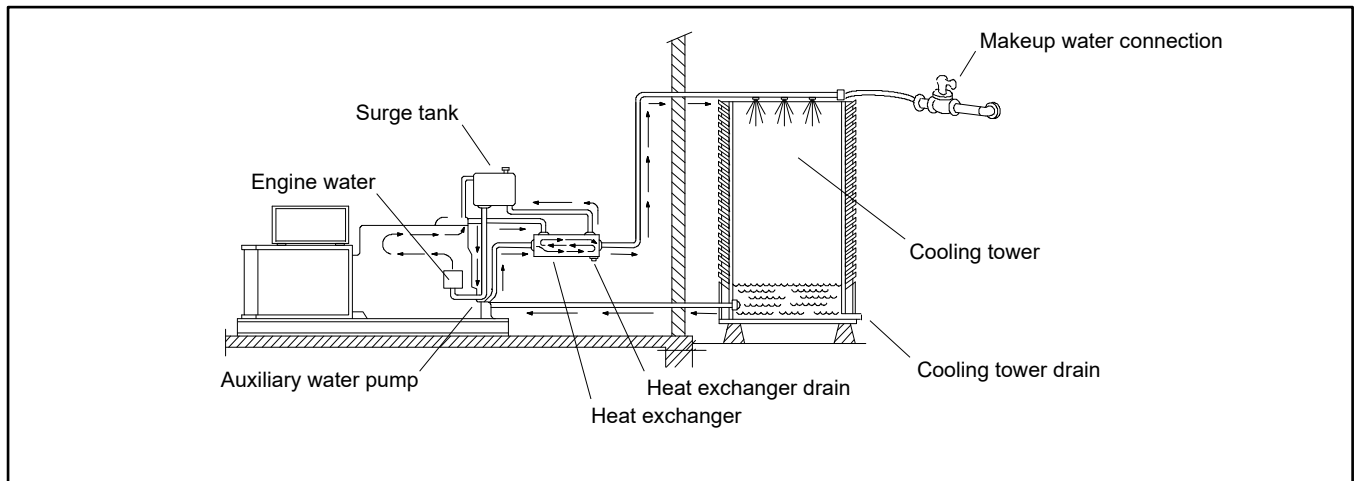

Figure 37 Cooling Tower System

4.8 Block Heaters

Block heaters are available as installed accessories on all generator sets. Generator sets installed in NFPA applications generally require use of a block heater. Equip generator sets with block heaters on all standby applications where the generator set is subject to temperatures below the value stated on the respective generator set specification sheet. Connect the block heater to a power source that is energized when the generator set is not running. The block heater thermostat temperature is set for optimum operation based on the respective engine cooling characteristics.

Note:

Block heater damage. The block heater will fail if the energized heater element is not immersed in coolant. Before energizing the block heater, fill the cooling system, run the engine until it is warm, and refill the radiator to purge the air from the system.

Section 5. Exhaust System

Satisfactory generator set performance requires proper exhaust system installation. The following sections detail arrangements of typical exhaust systems and exhaust system components.

5.1 Flexible Exhaust Line

Install a section of seamless stainless steel flexible exhaust line at least 305 mm (12 in.) long within 610 mm (2 ft.) of the engine exhaust outlet. See Figure 38 and Figure 39.

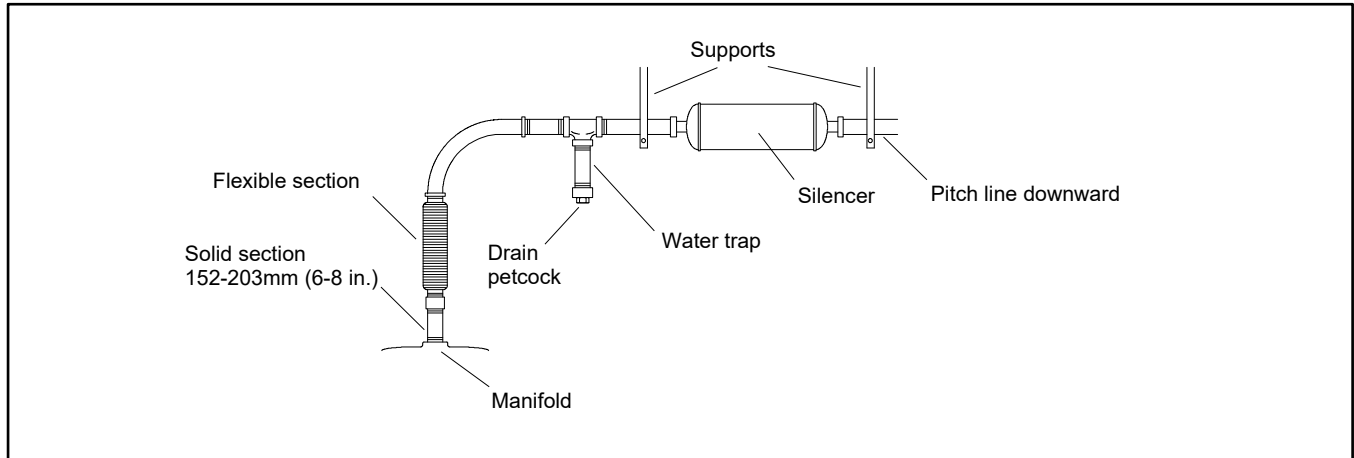

Figure 38 Exhaust System, End Inlet Silencer

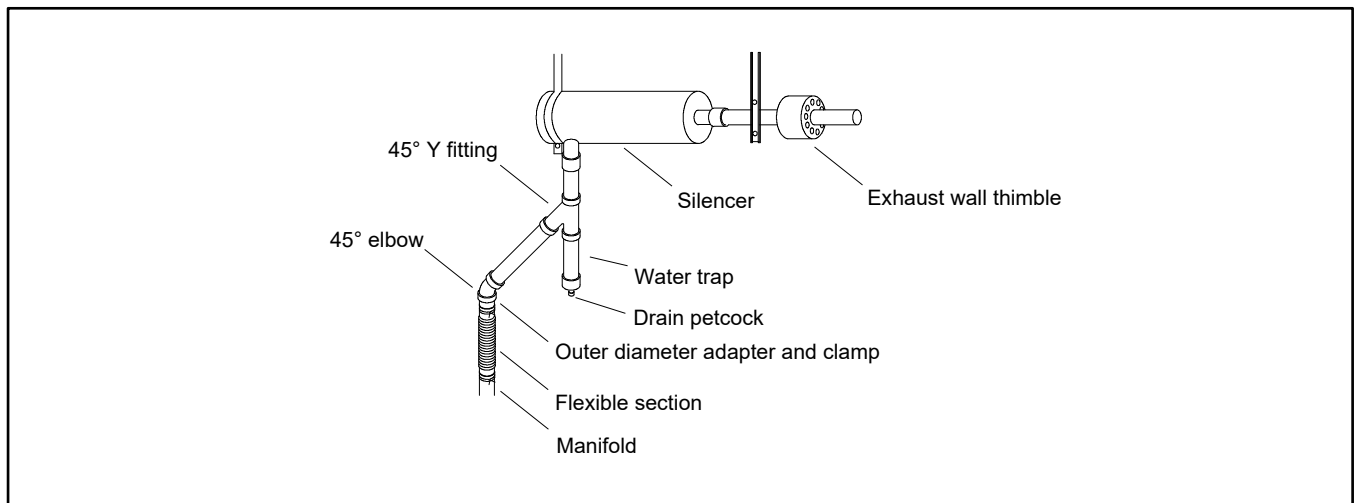

Figure 39 Exhaust System, Side Inlet Silencer

The flexible line limits stress on the engine exhaust manifold or turbocharger. Never allow the engine manifold or turbocharger to support the silencer or exhausting piping.

Note:

Do not bend the flexible section or use it to compensate for misalignment between the engine exhaust and the exhaust piping.

When using threaded flexible exhaust connectors, place a 152–203 mm (6–8 in.) length of pipe between the flexible exhaust connectors and the exhaust manifold. See Figure 38. The pipe reduces the temperature of the flexible connection, simplifies flexible section removal, and reduces strain on the engine exhaust manifold.

5.2 Condensation Trap

Some silencers are equipped with a drain pipe plug for draining condensation; see Figure 40. Otherwise, install a wye- or tee-type condensation trap with a drain plug or petcock between the engine and the exhaust silencer as shown in Figure 41. The trap prevents condensed moisture in the engine exhaust from draining into the engine after shutdown. Periodically drain collected moisture from the trap.

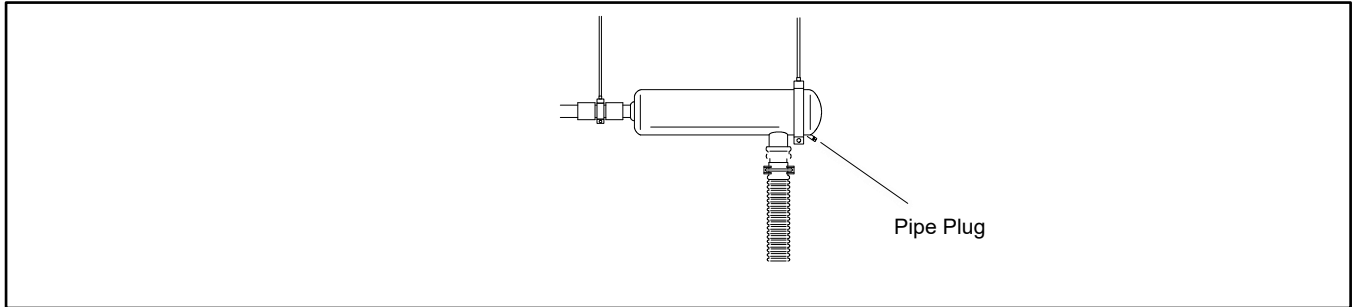

Figure 40 Silencer Condensation Drain Plug

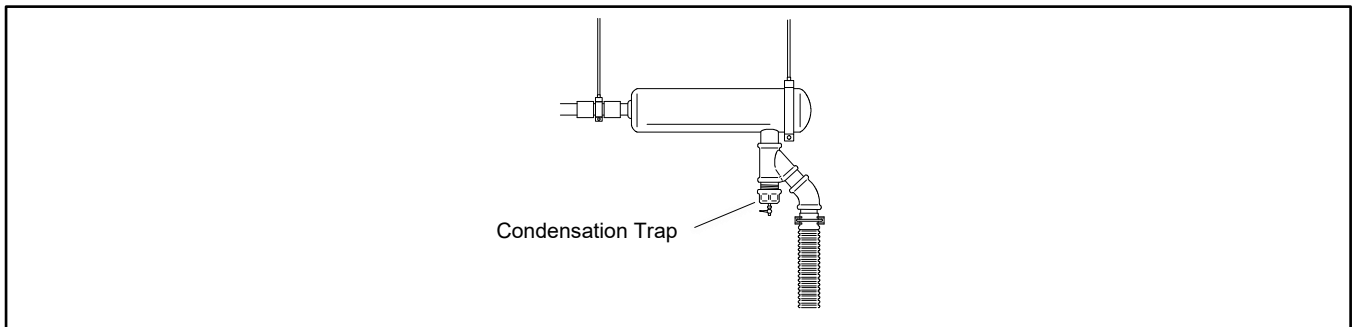

Figure 41 Condensation Trap

5.3 Piping

Note:

Select piping with a diameter that is the same size as, or larger than, the manifold outlet's inside diameter.

- Keep exhaust lines as short and straight as possible.
- Use schedule 40 black-iron pipe.
- Use sweep elbows with a radius of at least three times the pipe diameter wherever possible to minimize restriction.
- Use exhaust piping that conforms to applicable codes.
- Support the exhaust piping securely, allowing for thermal expansion. Assure the piping is not placing a high mount load on the turbocharger, when applicable.
- Insulate the exhaust piping with high-temperature insulation to reduce the heat rejected by exhaust piping and consequently the amount of ventilating air required and the temperature rise to radiator core.

In general, exhaust temperatures measured at the engine's exhaust outlet are less than 538°C (1000°F), except for infrequent brief periods; therefore, low-heat appliance standards apply. Each generator set specification sheet provides exhaust temperatures.

For units with exhaust temperatures below 538°C (1000°F), route the exhaust piping a minimum of 457 mm (18 in.) from combustible material, including building materials and natural surroundings. If exhaust temperatures exceed 538°C (1000°F), the minimum distance is 914 mm (36 in.).

When planning exhaust silencer and piping placement, consider the location of combustible materials. Insulating the exhaust system piping downstream of the turbocharger is acceptable, however it is not acceptable to apply an insulation wrap to the turbocharger. If the proximity of the exhaust system to the combustible materials cannot be avoided, follow a regular maintenance schedule to ensure that combustible materials are kept away from the exhaust pipes after installation. Combustible materials include building materials as well as natural surroundings. Keep dry field grass, foliage, and combustible landscaping material a safe distance from the exhaust system.

5.4 Double-Sleeved Thimbles

If the exhaust pipe passes through a wall or roof, use a double-sleeved exhaust thimble to prevent the transmission of exhaust pipe heat to the combustible material. Figure 42 shows construction details of a typical double-sleeved thimble in which exhaust piping passes through a combustible structure. Sheet metal shops usually fabricate thimbles using installation engineer's specifications and drawings.

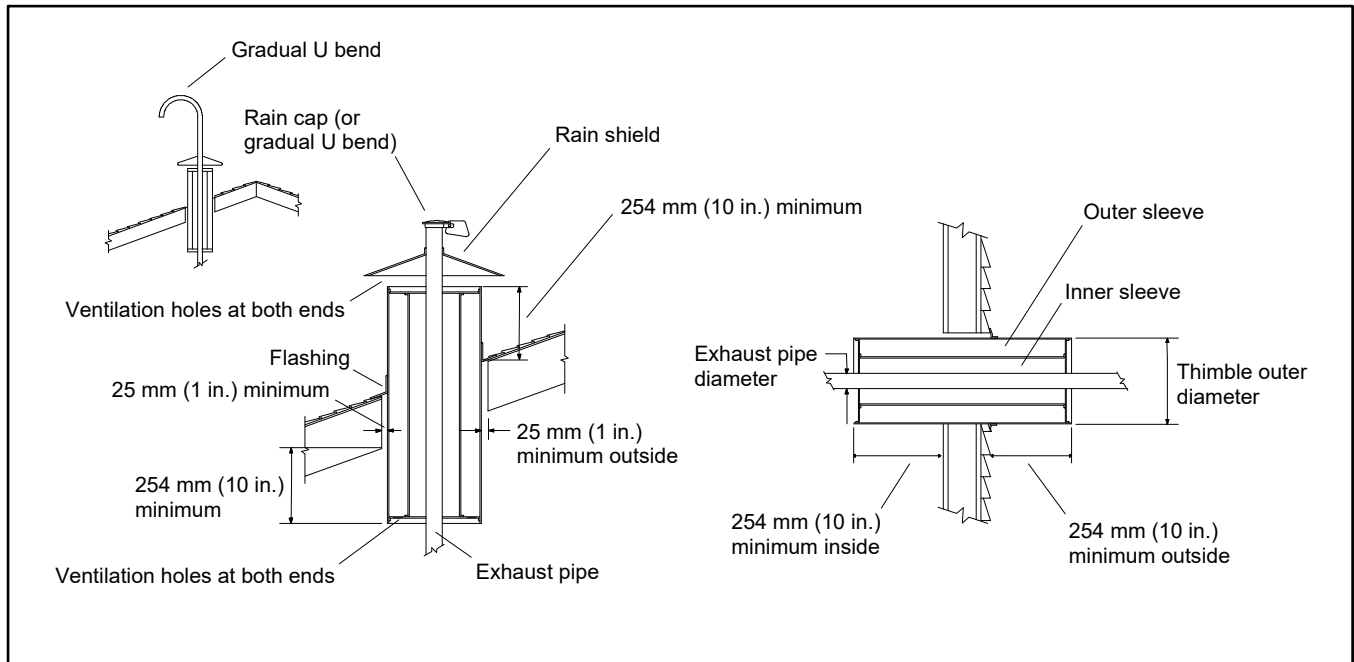

Figure 42 Double-Sleeved Thimbles and Rain Cap

Construct the thimble so it extends at least 254 mm (10 in.) both inside and outside the structure's surface. Openings at both ends of the thimble allow cooling air to circulate through the thimble. If screening is used on the outer end to keep birds and animals from entering the thimble, use a mesh large enough to allow unrestricted air circulation through the thimble. See the following section on Exhaust Outlet for additional exhaust outlet location and protection considerations.

5.5 Exhaust Outlet

Outlet location

Engine performance and efficiency depend on the location of the exhaust outlet. Direct the exhaust outlet away from the air inlet to prevent exhaust gases from entering the air inlet and clogging the dry-type air filter elements. Hot exhaust drawn through the intake air filters and radiator adversely affects engine cooling and engine performance. Locate the exhaust outlet to prevent exhaust fumes from entering a building or enclosure.

Noise reduction

The exhaust outlet configuration affects the apparent noise level for people or animals in the vicinity. An upward-directed outlet seems quieter than one directed downward or horizontally. Additionally, a 30- to 45-degree angled cut at the end of a horizontal exhaust outlet pipe reduces turbulence at the outlet, thereby reducing the noise level.

Rain cap

To prevent precipitation from entering the exhaust pipe, install a rain cap on vertical outlets. In a climate where freezing is common, check the installation and see if there is a risk that the rain cap could freeze in a closed position. The recommended option is to extend the exhaust piping at least 610 mm (24 in.) beyond the roof line and create a gradual U bend at the end to direct the exhaust outlet downward or utilize a mitered horizontal pipe discharge. Keep the pipe outlet at least 457 mm (18 in.) from the roof to prevent hot exhaust from igniting the roof material.

Generator set with enclosure

To avoid exceeding the engine manufacturer's maximum allowable backpressure specification, enclosure tail pipe extensions or attachments are not recommended.

5.6 Exhaust System Backpressure

Exhaust backpressure limits engine power and excessive backpressure causes serious engine damage. Excessive backpressure usually results from one or more of the following reasons:

- The exhaust pipe diameter is too small.
- The exhaust pipe is too long.
- The exhaust system has too many sharp bends.
- The exhaust silencer is too small.
- The exhaust silencer is not the correct design for the application.

Use the following procedure to verify that the installed exhaust system does not exceed the engine's maximum exhaust backpressure limit as specified in the generator set specification sheet.

Exhaust System Backpressure Calculation Procedure

Determine the total backpressure by calculating the effects of the individual exhaust system components and adding the results. Make calculations using either English or metric units. Exhaust pipe references are nominal pipe NPT (in.) sizes. The procedure shows an example with italic text. Calculations relate to end inlet silencers.

Note:

When calculating backpressure drop for side inlet silencers, use the end inlet values shown and add 0.75 kPa (0.25 in. of mercury or 3.4 in. of water) to backpressure calculations.

1. Select the exhaust silencer type for the application—hospital, critical, residential, or industrial. See the silencer specification sheet for definitions for each exhaust silencer type. Confirm silencer type availability for your generator set with your authorized distributor/dealer, as some generator sets do not use all four types.

Example: Determine the silencer backpressure for the recommended critical silencer on a 230 kW, 60 Hz diesel generator set.

2. Refer to the generator set specification sheet for:
 - a. Engine exhaust flow at rated kW in m³/min. (cfm)
Example: 57.5 m³/min. (2030 cfm)
 - b. Maximum allowable backpressure in kPa (in. of Hg)
Example: 10.2 kPa (3.0 in. Hg)
3. Refer to the submittal catalog for:
 - a. The recommended critical silencer part number
Example: 343616
 - b. Silencer inlet diameter in mm (in.)
Example: 152 mm (6 in.)
 - c. Silencer inlet position (end or side)
Example: end inlet
 - d. The flexible exhaust adapter part number
Example: 343605
 - e. Flexible exhaust adapter, flexible section length
Example: 857 mm (33.75 in.)

4. Determine the exhaust gas velocity through the silencer as follows:
 - a. Using the exhaust silencer inlet diameter determined in step 3, determine corresponding inlet area using Figure 43.

Example: 0.0187 m^2 (0.201 sq. ft.)

- b. Use this data to calculate the exhaust gas velocity. Divide the engine exhaust flow from step 2 in m^3/min . (cfm) by the silencer inlet area m^2 (sq. ft.) to get flow velocity in m (ft.) per minute.

Example:

$57.5 \text{ m}^3/\text{min} / 0.0187 \text{ m}^2 = 3075 \text{ m/min}$. ($2030 \text{ cfm} / 0.201 \text{ sq. ft.} = 10100 \text{ ft./min.}$)

Nominal Pipe Size, in. NPT	Inlet Area, m^2	Inlet Area, ft^2
1	0.00056	0.0060
1 ¼	0.00097	0.0104
1 ½	0.00131	0.0141
2	0.00216	0.0233
2 ½	0.00308	0.0332
3	0.00477	0.0513
4	0.00821	0.0884
5	0.0129	0.139
6	0.0187	0.201
8	0.0322	0.347
10	0.0509	0.548
12	0.0722	0.777
14	0.0872	0.939
16	0.1140	1.227
18	0.1442	1.553

Figure 43 Cross Sectional Area for Standard Silencer Sizes

5. Refer to Figure 44. Use the exhaust gas velocity determined in step 4 and find the exhaust gas velocity value in thousands on the bottom scale. Move vertically up until this value intersects the curve of the corresponding silencer type as determined in step 1. Move left on the horizontal axis and determine the backpressure drop value in kPa (in. of Hg).

Example: Exhaust velocity, 3075 m/min . (10100 ft./min.) intersects with critical silencer curve B and the corresponding backpressure value is approximately 2.8 kPa ($0.85 \text{ in. of mercury}$). Silencer type is end inlet from step 3 information with no additional backpressure drop value per the following note.

Note:

When calculating backpressure drop for side inlet silencers, use the end inlet values shown and add 0.75 kPa ($0.25 \text{ in. of mercury}$ or 3.4 in. of water) to backpressure calculations.

Note:

Refer to Figure 45 to calculate in inches of water and feet per minute.

6. Total the number of elbows and flexible sections in the exhaust system between the engine and the exhaust system outlet. Compare the radius of the bend (R) to the pipe diameter where (D) is the nominal pipe diameter in inches. Determine the equivalent length in m (ft.) of straight pipe for the elbows and flexible sections from the following:

Bend Angle	Type	Bend Radius	Conversion Factor
90°	Close	$R = D$	$32 \times D^* / 12$
90°	Medium	$R = 2D$	$10 \times D^* / 12$
90°	Sweep	$R = 4D$	$8 \times D^* / 12$
90°	Close	$R = D$	$15 \times D^* / 12$
90°	Sweep	$R = 4D$	$9 \times D^* / 12$
	Flex Sections		$2 \times \text{Length}^{**} / 12$

* Use the diameter of the silencer inlet in inches from step 3 for the initial calculation. If the results from step 9 indicate excessive backpressure drop, then recalculate using the larger-diameter pipe size selected.

** Use the flexible exhaust adapter length from step 3 and add any additional flex sections in the exhaust system expressed in inches

Convert the equivalent pipe length calculated in feet to meters using $\text{ft.} \times 0.305 = \text{m}$, as needed.

Examples:

45° sweep elbows:

$9 \times 6.0 \text{ in.} / 12 = 4.5 \text{ equiv. ft. or } 1.4 \text{ equiv. m}$

90° close elbows:

$32 \times 6.0 \text{ in.} / 12 = 16.0 \text{ equiv. ft. or } 4.9 \text{ equiv. m}$

Flexible sections:

$2 \times 33.75 \text{ in.} / 12 = 5.6 \text{ equiv. ft. or } 1.7 \text{ equiv. m}$

Equivalent of straight pipe:

$4.5 + 16.0 + 5.6 = 26.1 \text{ equiv. straight ft.}$

$1.4 + 4.9 + 1.7 = 8.0 \text{ equiv. straight m}$

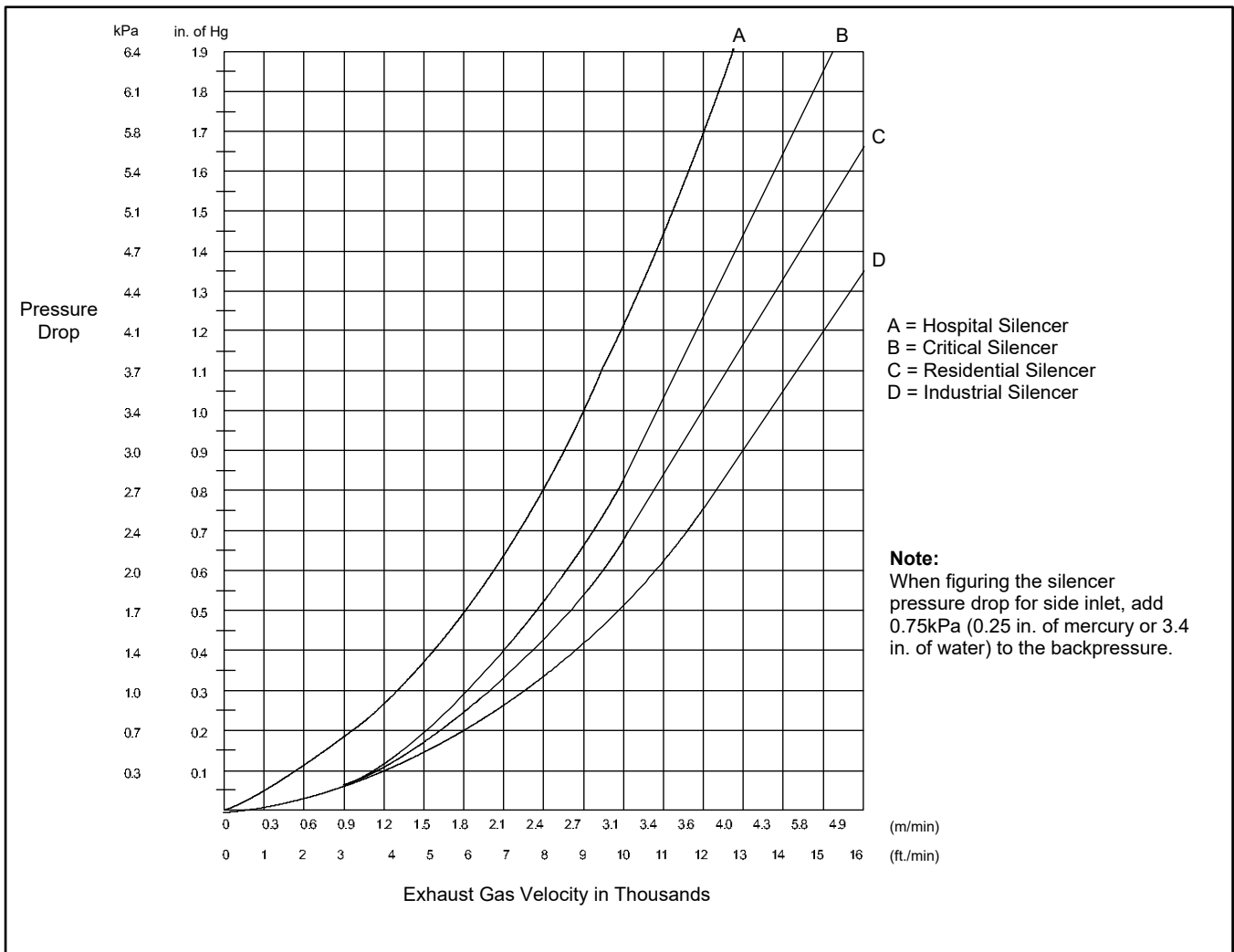

Figure 44 Silencer Backpressure Drop (in. of Hg)

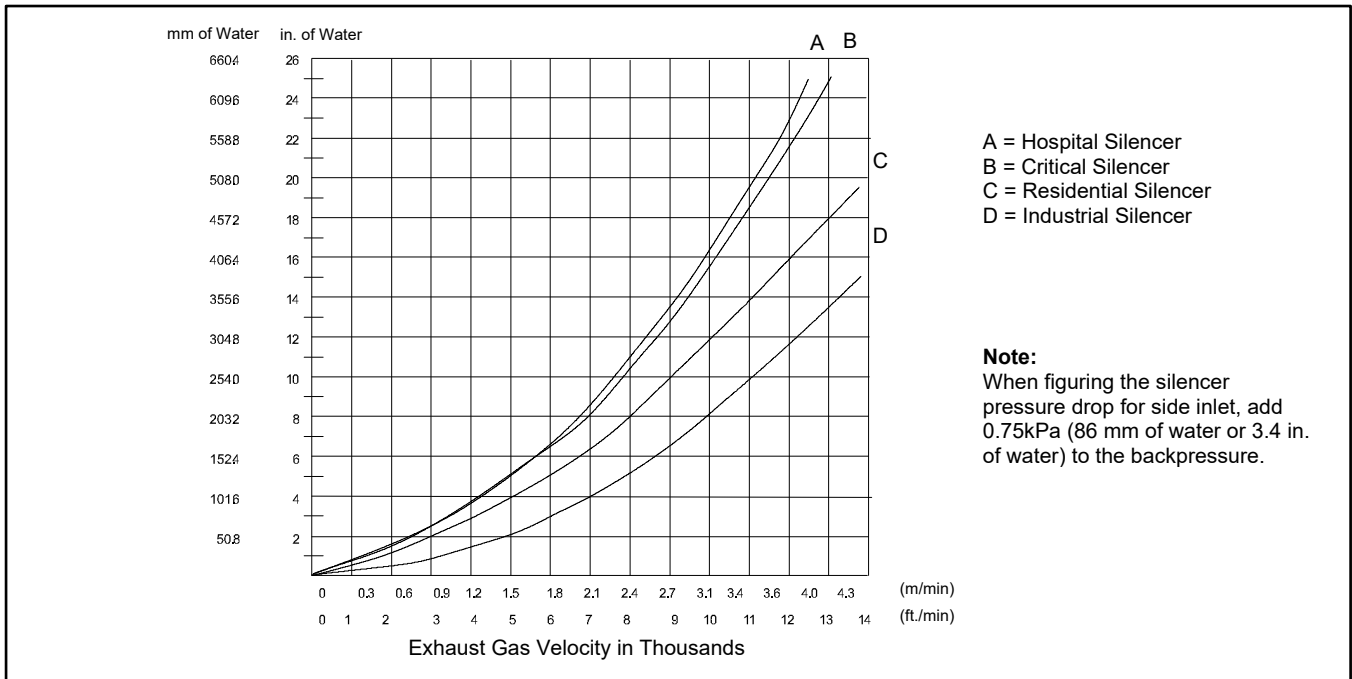

Figure 45 Silencer Backpressure Drop (in. of water)

- Determine the total length of straight pipe used in the exhaust system. Add this calculation to the equivalent length for elbows and flexible sections obtained in step 6.

Example:

Straight pipe = 3.0 m (10 ft.).

Equivalent straight pipe from step 6: 8.0 m (26.1 ft.)

3.0 m + 8.0 m = 11.0 m or

10 ft. + 26.1 ft. = 36.1 ft. total

- Refer to Figure 46 if the pipe size is 102 mm (4 in.) or less or Figure 47 if the pipe size is 127 mm (5 in.) or larger.

Place a straight edge across the chart with the edge in line with the pipe size in inches (D) on the right column from step 3 and the engine exhaust flow (Q) from step 2 on the left column.

Read backpressure kPa/m or in. of Hg/ft. (ΔP) from the center column. Calculate the total piping system backpressure by multiplying the total equivalent straight pipe in m (ft.) from step 7 by the kPa/m or in. of Hg/ft. of pipe from this step.

Example:

11.0 equiv. m x 0.04 kPa/m =

0.4 total system backpressure in kPa

36.1 equiv. ft. x 0.004 in. Hg/ft. =

0.14 total system backpressure in inches of Hg

9. Add the backpressure of the piping determined in step 8 to the backpressure of the silencer determined in step 5. The total should not exceed the engine manufacturer's maximum allowable system backpressure determined in step 2 or on the generator set's specification sheet. If the total exceeds the maximum, use a larger pipe size or silencer or both. Repeat the calculation if new components are selected to verify that the system backpressure would not exceed the limit using the larger component(s).

Example:

0.4 kPa (step 8) + 2.8 kPa (step 5) = 3.2 kPa Maximum allowable backpressure = 10.2 kPa $3.2 < 10.2$ backpressure drop is acceptable

0.14 in. Hg. (step 8) + 0.85 in. Hg. (step 5) =

0.99 in. Hg.

Maximum allowable backpressure = 3.0 in. of Hg. $0.99 < 3.0$ backpressure drop is acceptable

Q Engine Exhaust Flow

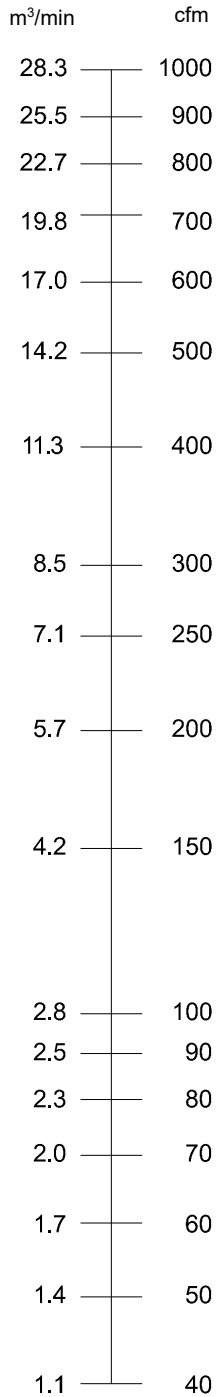

(Cfm x 0.02832 = m³/min.)

D P Backpressure

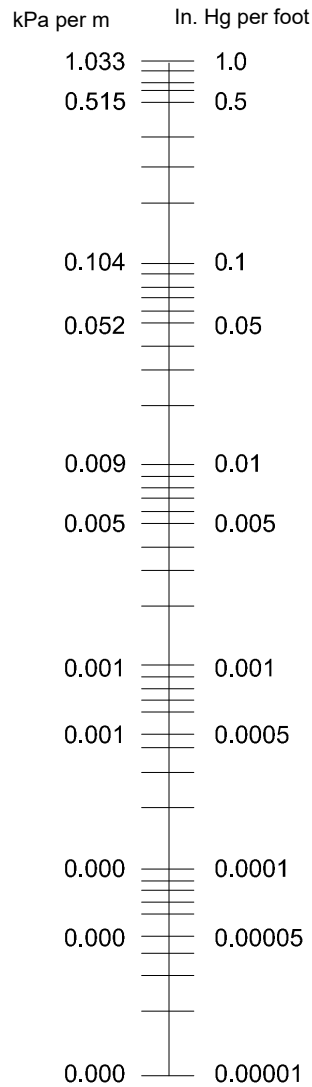

(in. Hg x 3.387 = kPa)

D Pipe Diameter

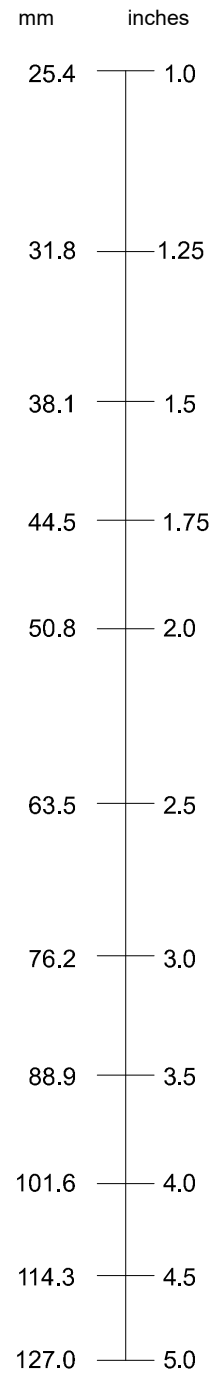

(in. x 25.4 = mm)

Figure 46 Backpressure using Pipe Size 4 in. (102 mm) or Less

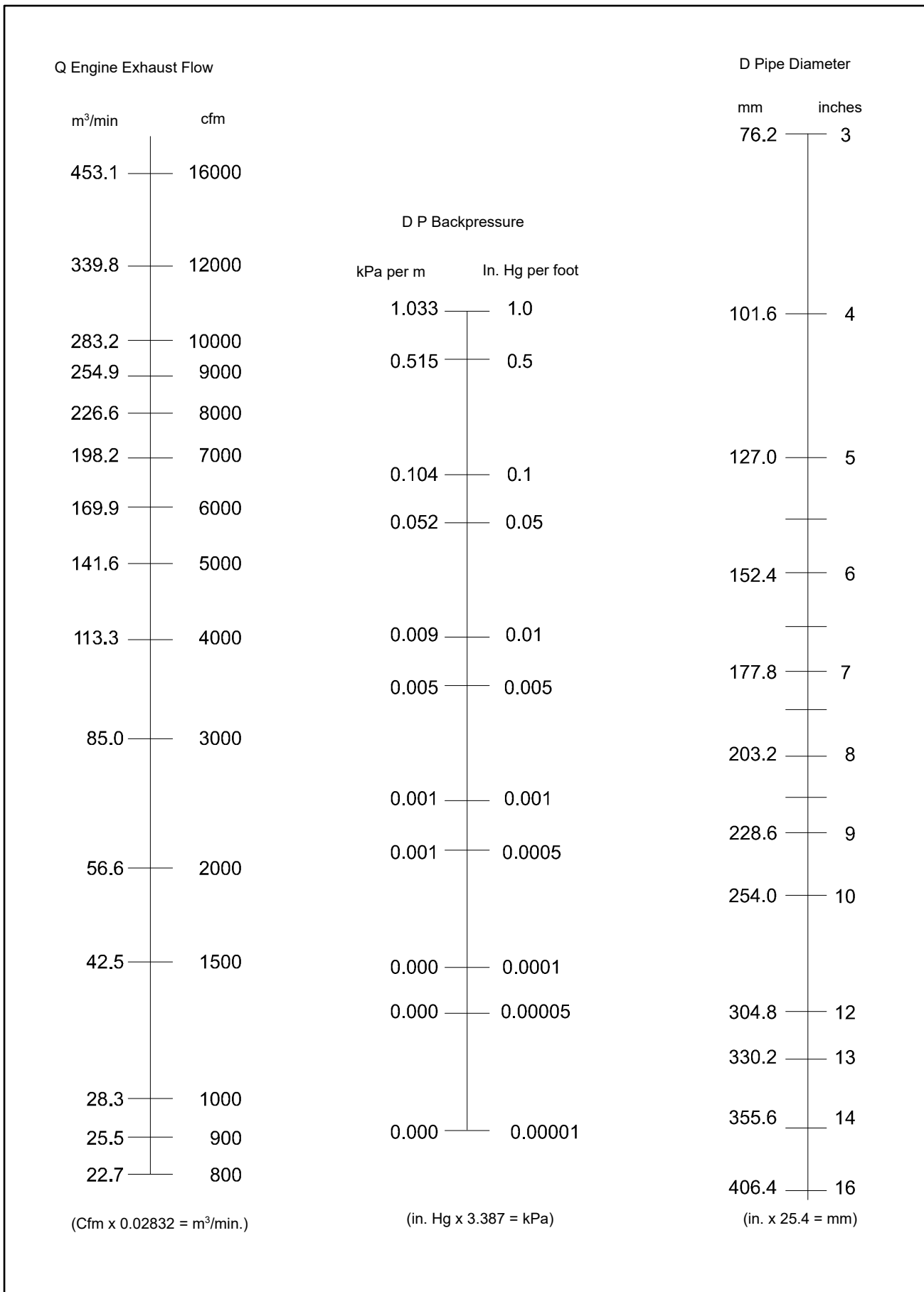







Figure 47 Backpressure using Pipe Size 5 in. (127 mm) or Larger

Notes

Section 6. Fuel System

Comply with applicable state and local codes when installing any fuel system.

 WARNING	Explosive fuel vapors. Can cause severe injury or death. Use extreme care when handling, storing, and using fuels.
 	

 WARNING	Avoid high pressure fluids. Can cause severe injury or death. Do not work on high pressure fuel or hydraulic systems without protective equipment to protect hands, eyes, and body. Avoid the hazard by relieving pressure before disconnecting fuel injection pressure lines. Search for leaks using a piece of cardboard. Always protect hands, eyes, and body from high pressure fluids. If an accident occurs, seek medical attention immediately.
	

The fuel system. Explosive fuel vapors can cause severe injury or death. Vaporized fuels are highly explosive. Use extreme care when handling and storing fuels. Store fuels in a well-ventilated area away from spark-producing equipment and out of the reach of children. Never add fuel to the tank while the engine is running because spilled fuel may ignite on contact with hot parts or from sparks. Do not smoke or permit flames or sparks to occur near sources of spilled fuel or fuel vapors. Keep the fuel lines and connections tight and in good condition. Do not replace flexible fuel lines with rigid lines. Use flexible sections to avoid fuel line breakage caused by vibration. Do not operate the generator set in the presence of fuel leaks, fuel accumulation, or sparks. Repair fuel systems before resuming generator set operation.

Explosive fuel vapors can cause severe injury or death. Take additional precautions when using the following fuels:

Gasoline—Store gasoline only in approved red containers clearly marked GASOLINE.

Propane (LPG)—Adequate ventilation is mandatory. Because propane is heavier than air, install propane gas detectors low in a room. Inspect the detectors per the manufacturer's instructions.

Natural Gas—Adequate ventilation is mandatory. Because natural gas rises, install natural gas detectors high in a room. Inspect the detectors per the manufacturer's instructions.



Fuel tanks. Explosive fuel vapors can cause severe injury or death. Gasoline and other volatile fuels stored in day tanks or subbase fuel tanks can cause an explosion. Store only diesel fuel in tanks.



Draining the fuel system. Explosive fuel vapors can cause severe injury or death. Spilled fuel can cause an explosion. Use a container to catch fuel when draining the fuel system. Wipe up spilled fuel after draining the system.

Gas fuel leaks. Explosive fuel vapors can cause severe injury or death. Fuel leakage can cause an explosion. Check the LPG vapor or natural gas fuel system for leakage by using a soap and water solution with the fuel system test pressurized to 6–8 ounces per square inch (10–14 inches water column). Do not use a soap solution containing either ammonia or chlorine because both prevent bubble formation. A successful test depends on the ability of the solution to bubble.

LPG liquid withdrawal fuel leaks. Explosive fuel vapors can cause severe injury or death. Fuel leakage can cause an explosion. Check the LPG liquid withdrawal fuel system for leakage by using a soap and water solution with the fuel system test pressurized to at least 90 psi (621 kPa). Do not use a soap solution containing either ammonia or chlorine because both prevent bubble formation. A successful test depends on the ability of the solution to bubble.

6.1 Diesel Fuel Systems

 WARNING	<p>Explosive fuel vapors. Can cause severe injury or death.</p> <p>Use extreme care when handling, storing, and using fuels.</p>
 	

 WARNING	<p>Avoid high pressure fluids. Can cause severe injury or death.</p> <p>Do not work on high pressure fuel or hydraulic systems without protective equipment to protect hands, eyes, and body. Avoid the hazard by relieving pressure before disconnecting fuel injection pressure lines. Search for leaks using a piece of cardboard. Always protect hands, eyes, and body from high pressure fluids. If an accident occurs, seek medical attention immediately.</p>
	

The fuel system. Explosive fuel vapors can cause severe injury or death. Vaporized fuels are highly explosive. Use extreme care when handling and storing fuels. Store fuels in a well-ventilated area away from spark-producing equipment and out of the reach of children. Never add fuel to the tank while the engine is running because spilled fuel may ignite on contact with hot parts or from sparks. Do not smoke or permit flames or sparks to occur near sources of spilled fuel or fuel vapors. Keep the fuel lines and connections tight and in good condition. Do not replace flexible fuel lines with rigid lines. Use flexible sections to avoid fuel line breakage caused by vibration. Do not operate the generator set in the presence of fuel leaks, fuel accumulation, or sparks. Repair fuel systems before resuming generator set operation.

Fuel tanks. Explosive fuel vapors can cause severe injury or death. Gasoline and other volatile fuels stored in day tanks or subbase fuel tanks can cause an explosion. Store only diesel fuel in tanks.

Draining the fuel system. Explosive fuel vapors can cause severe injury or death. Spilled fuel can cause an explosion. Use a container to catch fuel when draining the fuel system. Wipe up spilled fuel after draining the system.

The main components of a typical diesel fuel system are a main fuel storage tank, a day tank, fuel lines, and an auxiliary fuel pump. See Figure 48.

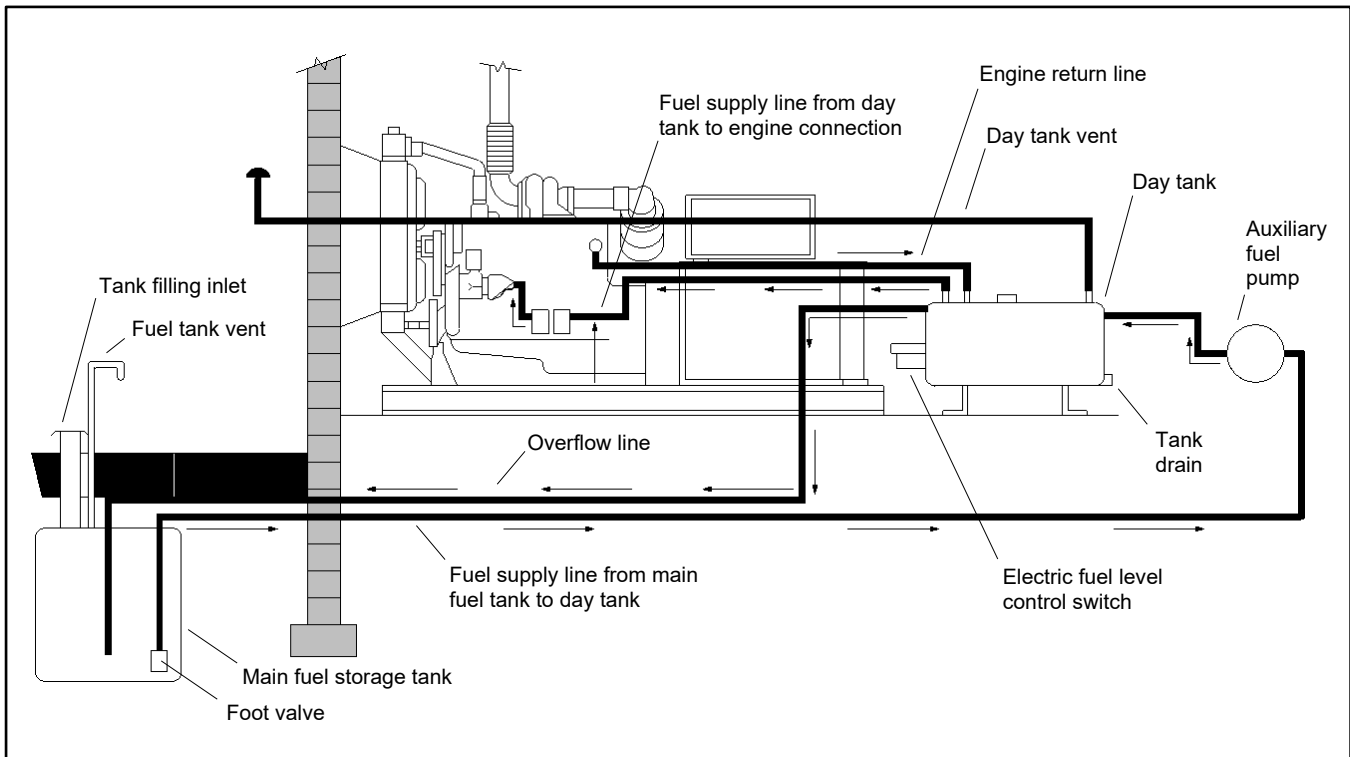

Figure 48 Diesel Fuel System

6.1.1 Main Tank

Storage

Because it is less volatile than gas or gasoline, diesel fuel is safer to store and handle. Regulations for diesel storage tank placement are less stringent than the regulations for gas or gasoline storage. In some locations, large main tanks are permitted inside the building or enclosure.

Tank location

Locate fuel storage tanks above ground or bury them underground in accordance with applicable codes. Figure 49 shows a commonly used above-ground subbase tank contained in the generator set mounting base.

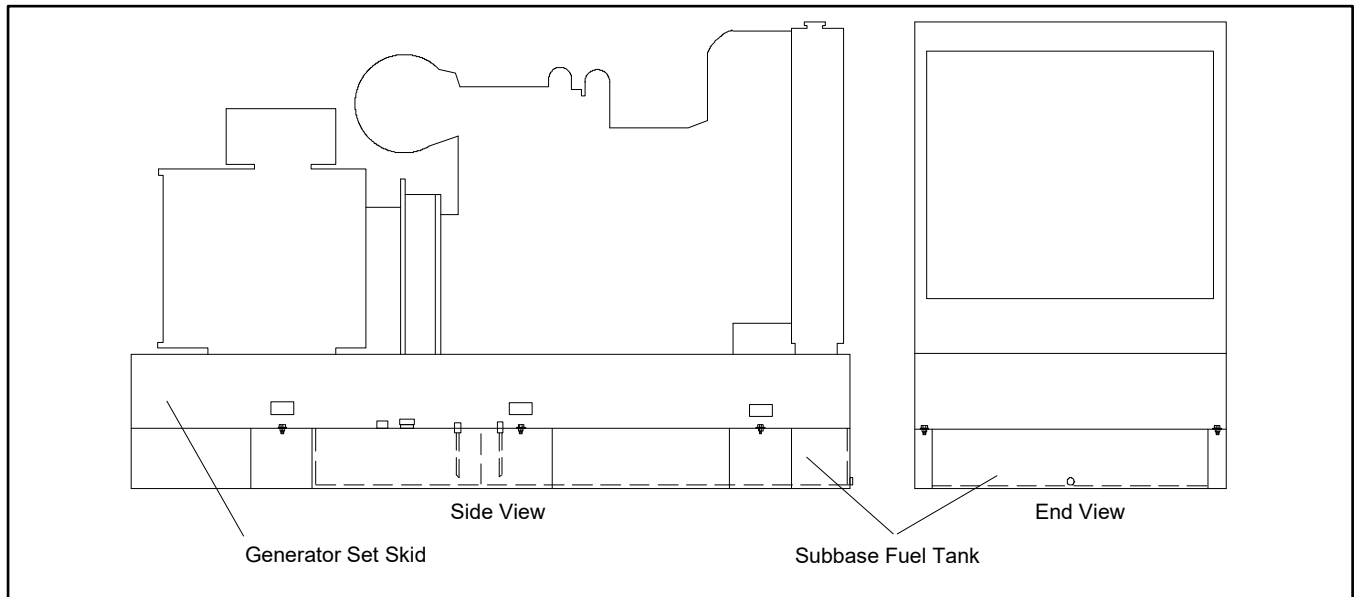

Figure 49 Subbase Fuel Tank

Tank size

Codes requiring standby power often specify a minimum onsite fuel supply. Such requirements are included in NFPA70, National Electrical Code, and NFPA99, Standard for Health Care Facilities. Diesel fuel deteriorates if stored for more than one year; therefore, size the tank to ensure that regular generator set exercising will use the tank's contents within one year. If there are no applicable code requirements, the manufacturer recommends a tank sized for eight hours of operation at rated load. Refer to the generator set specification sheet for fuel consumption data.

Tank venting

Vent the main fuel tanks to allow air and other gases to escape to the atmosphere without allowing dust, dirt and moisture to enter the tank.



Fuel expansion

Never fill the tank more than 95% full to allow for fuel expansion. On overhead main tanks, use a fuel shutoff solenoid to prevent hydraulic lock or tank overflow caused by excessive static head fuel pressures.

Fuel alternatives

Most diesel engines operate satisfactorily on No. 2 domestic burner oil available in most parts of the US. If the site heating system is oil-fired, consider supplying the engine with fuel from the same tank used for heating oil to reduce costs and to ensure a continually fresh fuel supply for the engine. This practice necessitates that the fuel oil meets the engine manufacturer's minimum requirements for wax point, pour point, sulfur content, and cetane number as these factors influence cold weather starting and generator set power output. When supplying multiple applications from the same main fuel tank, provide each with a separate supply line.

6.1.2 Fuel Tank Monitoring Panel

 DANGER	Hazardous voltage. Moving parts. Will cause severe injury or death. Operate the generator set only when all guards and electrical enclosures are in place.
 	

Short circuits. Hazardous voltage/current will cause severe injury or death. Short circuits can cause bodily injury and/or equipment damage. Do not contact electrical connections with tools or jewelry while making adjustments or repairs. Remove all jewelry before servicing the equipment.



Figure 50 Fuel Monitoring Panel, Overview

The fuel monitoring panel provides visual warning lights and audible alarms for low, 90%-full, and 95%-full tank fuel levels. To monitor these tank fuel levels, the fuel monitoring panel connects to switches through wiring harnesses that are protected by flexible conduit. If the fuel tank and the generator set enclosure are shipped separately, the wiring harness may need to be connected during the installation process. Because the generator set batteries provide DC voltage to power the fuel monitoring panel, an AC power supply is not needed for this accessory. The following procedure shows the connections for the wiring harness from the monitoring panel to the connections on the tank and batteries. See the system overview, Figure 50, and the wiring diagram, Figure 54.

Note:

The enclosure should be installed on the fuel tank before routing the wiring harness.

1. Use the following steps to remove the generator set from service.
 - a. Press the Emergency Stop (E-Stop) button on the generator set, if equipped.
 - b. Turn off the generator set by pressing the OFF/RESET button on the generator set controller or placing the generator set master switch in the OFF position.
 - c. Disconnect the power to any generator set accessories such as a battery charger.
 - d. Disconnect the generator set engine starting battery, negative (-) lead first.
 - e. Disconnect the generator set from load by opening the line circuit breaker.

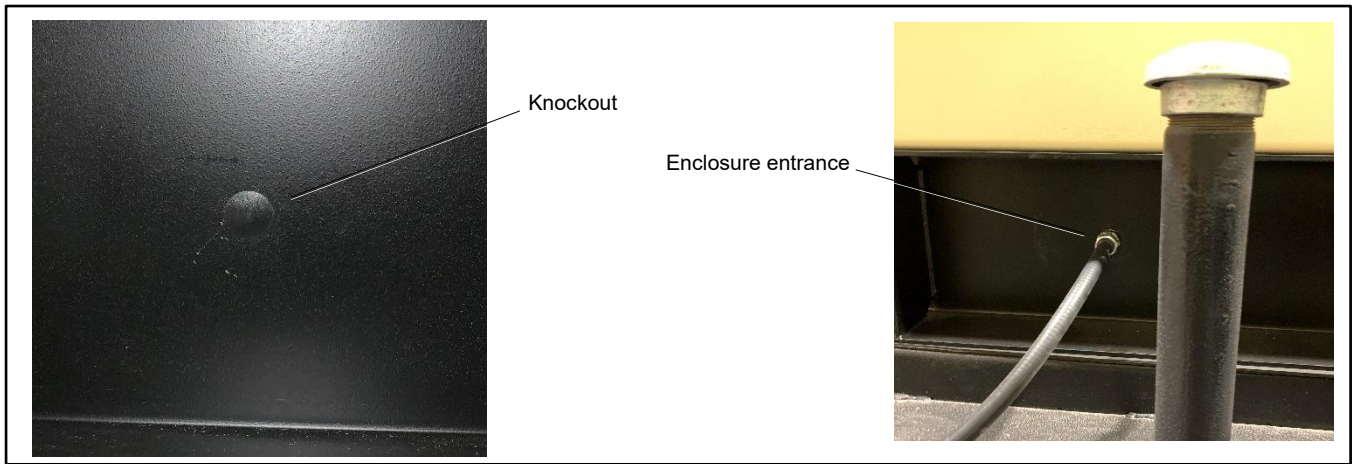

Figure 51 Enclosure Entrance

2. Locate and remove the knockout in the enclosure base. See Figure 51.
3. To secure the conduit to the enclosure:
 - a. From the enclosure exterior, insert the threaded end of the flexible conduit through the enclosure wall.
 - b. On the enclosure interior, use the lock washer to secure the conduit to the enclosure.
4. From the enclosure interior, route wiring harness, GM75504, through the enclosure wall and the flexible conduit.

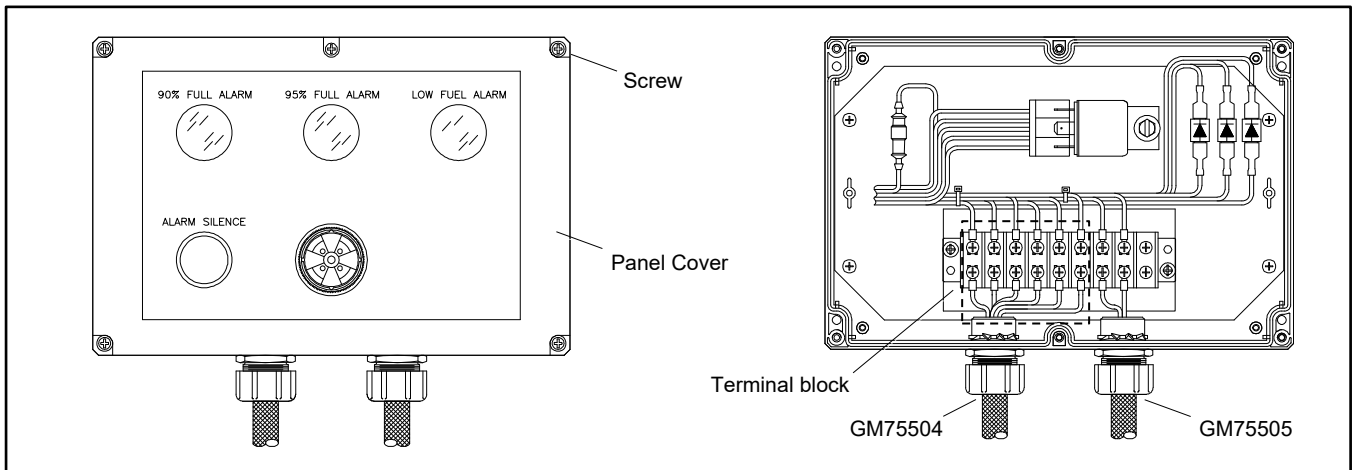

Figure 52 Panel Cover Removed

5. To remove the cover of the fuel monitoring panel:
 - a. Remove the five screw caps.
 - b. Remove the five screws. See Figure 52.
6. To connect the wiring harnesses to the fuel monitoring panel:
 - a. Insert the wiring harnesses, GM75504 (low fuel, battery power, and 95%-full fuel level), through entry holes in the bottom of the fuel monitoring panel.
 - b. Connect the wiring harness to the terminal block as shown in Figure 54.

Note:

The wiring harness, GM75505 (90%-full fuel level), is typically connected at the factory. If harness GM75505 is not installed, refer to the wiring diagram to complete the connections to the 90%-full fuel level switch.

7. Reposition the cover and secure with the five screws. Replace the screw caps.

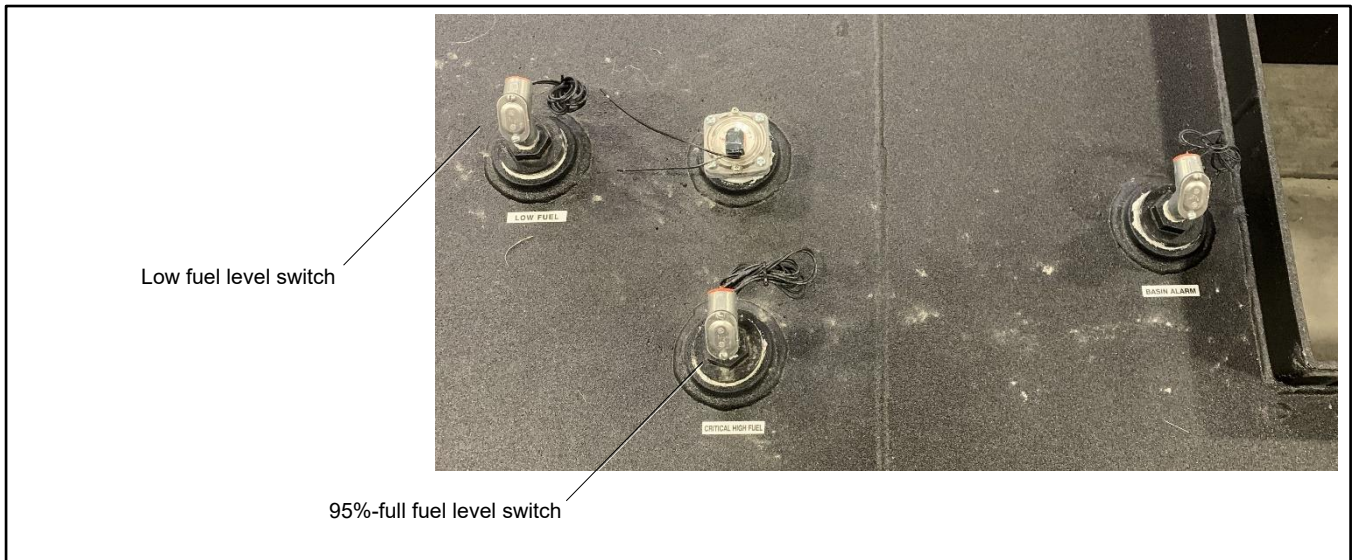

Figure 53 Wiring Harness Connections, GM75504

8. Inside the enclosure, make the following connections for the switches.
 - a. Connect the quick connects 3 and 4 to the 95%-full fuel level switch. See Figure 54.
 - b. Connect quick connects 5 and 6 to the low fuel level switch.
9. Position the battery ring terminals on the battery studs as follows:
 - a. Place the red ring terminal over the battery positive (+) stud.
 - b. Place the black ring terminal over the battery negative (-) stud.
10. Return the generator set to service.
 - a. Check that the manual key switch, if equipped, is in the OFF position.
 - b. Check that the Emergency Stop button is activated
 - c. Reconnect the generator set engine starting battery, negative (-) lead last.
 - d. Reconnect the power to any generator set accessories such as a battery charger or block heater.
 - e. Reconnect the generator set to load by closing the line circuit breaker.
 - f. Reset the Emergency Stop button.
 - g. Clear the emergency stop fault on the controller.
 - h. Return the generator set to normal operation by pressing the generator set master control AUTO or RUN button or by placing the generator set master switch in the AUTO or RUN position, as required.

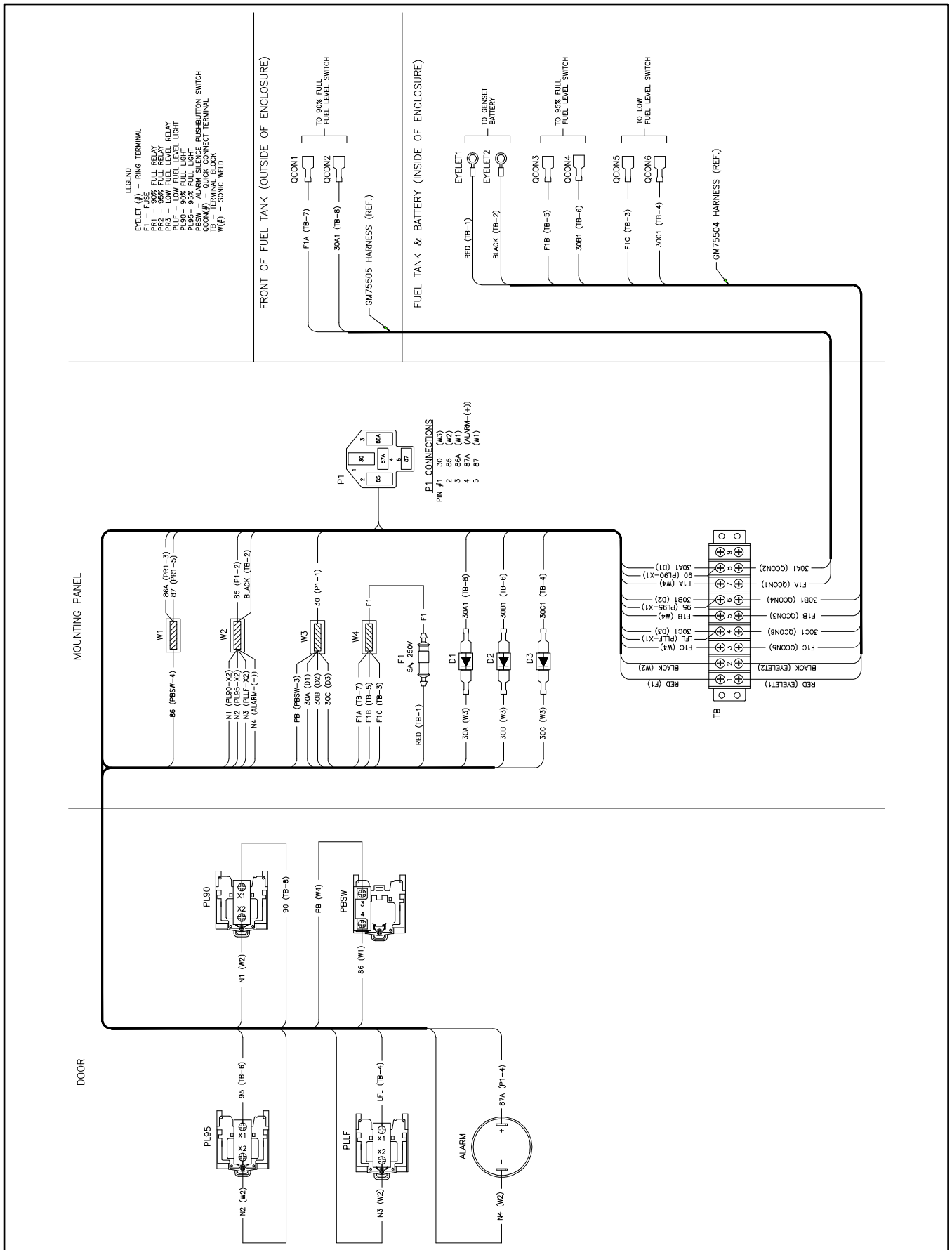

Figure 54 Fuel Monitoring Panel Wiring Diagram, GM86940 Sheet 2

6.1.3 Day Tanks

The terms day tank and transfer tank are interchangeable. Having a day tank adjacent to the engine allows the engine fuel transfer pump to easily draw fuel during startup and provides a convenient location to connect fuel return lines. See Figure 55.

Connect a float-switch-controlled solenoid antisiphon valve or a float valve to prevent siphoning fuel from the main storage tank if the main tank fuel level is above the day tank inlet.

Tank size

Standard tanks are available in sizes from 38-3952 L (10-1044 gal.) with or without integral electric fuel transfer pumps. Because engines are subject to fuel temperature deration above 38°C (100°F) and are subject to damage if operated with fuel temperatures above 60°C (140°F), a day tank providing at least four hours of fuel consumption should be used to provide enough capacity to cool the fuel returning from the engine. If smaller day tanks are used, the generator set manufacturer may recommend installing a fuel cooler or routing engine fuel return lines to the main storage tank. See Figure 55.

Optional equipment includes fuel level gauges, manual priming pumps, float switches for pump control, float valves, rupture basins, and low level alarms. Remove the plastic shipping plugs and install metallic pipe plugs in all unused fuel tank ports to provide a liquid-tight seal.

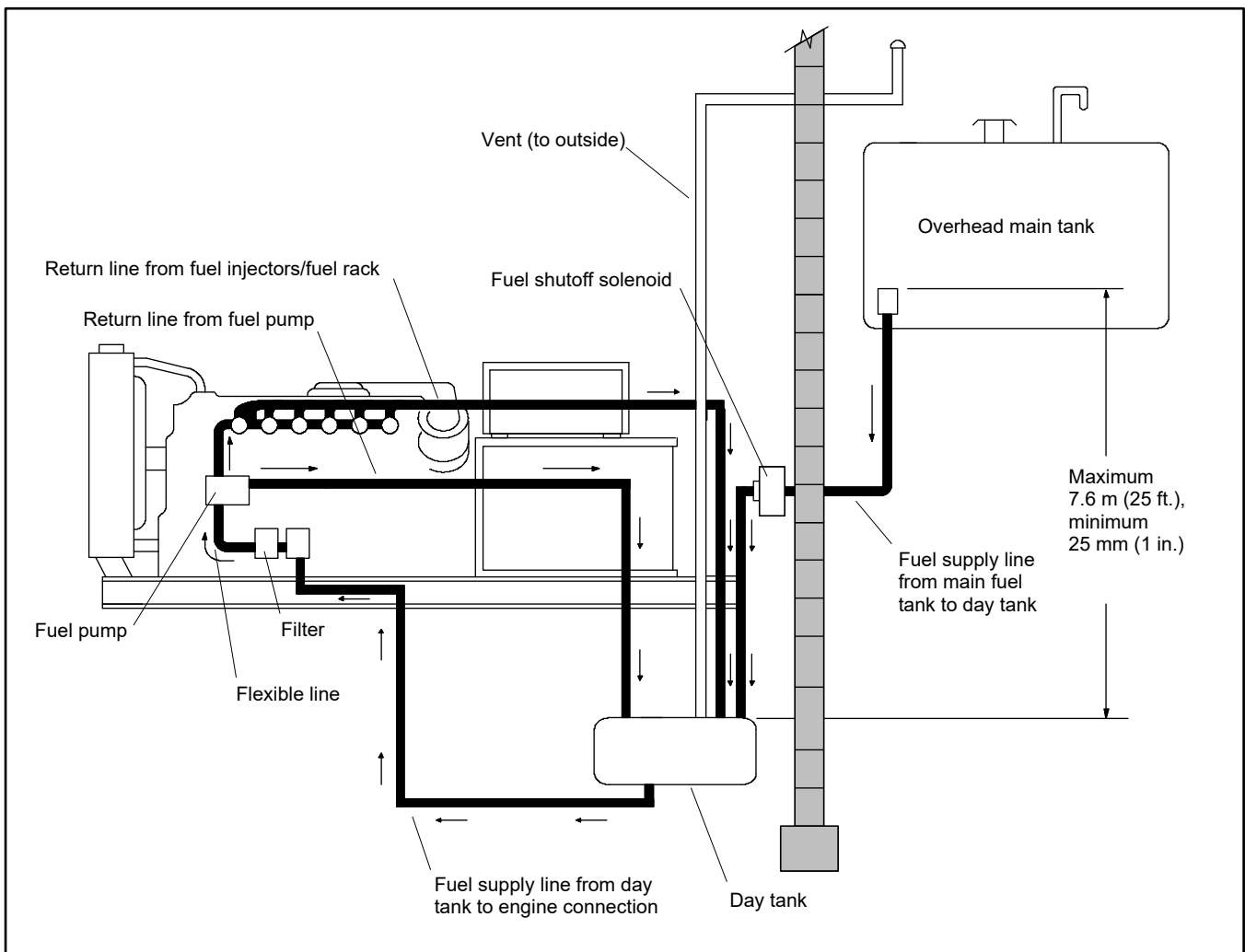

Figure 55 Diesel Fuel System with Overhead Main Tank and Day Tank

6.1.4 Fuel Lines

The following items describe fuel line selection and application. Never use the fuel piping or fuel line clamps to ground any electrical equipment.

Use Schedule 40 black-iron pipe or other materials which do not contain the below listed elements.

- Barium (Ba)
- Calcium (Ca)
- Copper (Cu)
- Lead (Pb)
- Magnesium (Mg)
- Phosphorous (P)
- Potassium (K)
- Sodium (Na)
- Zinc (Zn)

These metals react adversely with diesel fuel to form deposits on the fuel system causing a gradual decrease in fuel system efficiency and eventually can cause fuel system failure. Use of such materials may affect fuel system warranty.

Note:

The KD and KDI TCR engines require that the above elements are not present in the fuel system components.

Line size

Use the smallest diameter fuel line that still delivers enough fuel to the engine with an acceptable pressure drop of 6.9 kPa (1.0 psi). Using oversize piping increases the chance of air introduction into the fuel system during engine priming, which increases the potential for fuel pump damage and hard starting.

Flexible connectors

Use flexible connections spanning a minimum of 152 mm (6 in.) between the stationary piping and the engine fuel inlet connection.

Return lines

A diesel system delivers more fuel to the injectors than the engine uses; therefore, a system has one supply line from the fuel tank and at least one return line from the fuel injectors. Size the fuel return lines no smaller than the fuel supply lines.

Route the return fuel line to either the day tank or the main storage tank. Place the return lines as far away from the pickup or fuel dip tube as possible to prevent air entry and to keep warm fuel from being reintroduced to the engine. If fuel lines are routed to the day tank, note the day tank size requirements in the previous section, Day Tanks.

A properly designed fuel return line is unrestricted and as short as possible, and it allows gravity return of fuel to the storage tanks. In installations where gravity return is not possible, obtain approval of the design from the generator set supplier based upon the engine's specifications before installing a fuel system with static head pressure on the return lines. Fuel return line restriction can cause engine hydraulic lock or uncontrollable overspeed on some systems.

6.1.5 Auxiliary Fuel Pumps

Primary, engine-driven fuel pumps typically develop a maximum of 48 kPa (7 psi) pressure and draw fuel to approximately 1.2-1.4 m (4-5 ft.) vertically or 6 m (20 ft.) horizontally. When the main tank is located a greater distance from the engine or for a more reliable fuel system, use an auxiliary pump alone or in combination with a day tank. Limit auxiliary fuel pump pressure to approximately 35 kPa (5 psi).

Use a shutoff solenoid valve wired into the engine run circuit or a check valve to help keep the fuel line primed. Install the check valve on the outlet side of the auxiliary fuel pump to minimize inlet restriction.

Auxiliary fuel pump options.

On engines using less than 38 L (10 gal.) of fuel per hour (approximately 100 kW or less), connect an engine starting battery-powered electric fuel transfer pump in series with the engine-driven transfer pump. Locate the electric pump nearer to the fuel tank than to the engine. An auxiliary pump located at the fuel tank approximately doubles the horizontal and vertical distance limits of a single engine-driven pump.

On engines using more than 38 L (10 gal.) of fuel per hour or when drawing fuel more than 1.8 m (6 ft.) vertically or 12 m (40 ft.) horizontally, use an electric motor-driven positive displacement pump with a day tank and float switch. Electrically connect the fuel pump to the transfer switch load side for maximum reliability. This type of pump can typically lift fuel 5.5 m (18 ft.) or draw it horizontally up to 61 m (200 ft.).

Where vertical runs exceed 5.5 m (18 ft.) or horizontal runs exceed 61 m (200 ft.), remote-mount the pump adjacent to the fuel storage tank. This type of installation allows these pumps to push fuel over 305 m (1000 ft.) horizontally or more than 31 m (100 ft.) vertically and deliver adequate fuel for generator sets up to 2000 kW. Always connect a positive-displacement pump directly to a day tank and float switch to protect the engine fuel system from excessive fuel pressures.



6.2 Gas Fuel Systems, Common Components

Gas fuel systems operate on either LP (liquefied petroleum) or natural gas.

Note:

Design and install gas fuel systems in accordance with NFPA 54, National Fuel Gas Code, and applicable local codes.

All gas systems include a carburetor, secondary gas regulator, electric gas fuel solenoid shutoff valve, and flexible fuel connector.

 WARNING	Explosive fuel vapors. Can cause severe injury or death.
 	Use extreme care when handling, storing, and using fuels.

The fuel system. Explosive fuel vapors can cause severe injury or death. Vaporized fuels are highly explosive. Use extreme care when handling and storing fuels. Store fuels in a well-ventilated area away from spark-producing equipment and out of the reach of children. Never add fuel to the tank while the engine is running because spilled fuel may ignite on contact with hot parts or from sparks. Do not smoke or permit flames or sparks to occur near sources of spilled fuel or fuel vapors. Keep the fuel lines and connections tight and in good condition. Do not replace flexible fuel lines with rigid lines. Use flexible sections to avoid fuel line breakage caused by vibration. Do not operate the generator set in the presence of fuel leaks, fuel accumulation, or sparks. Repair fuel systems before resuming generator set operation.

Explosive fuel vapors can cause severe injury or death. Take additional precautions when using the following fuels:

Propane (LPG)—Adequate ventilation is mandatory. Because propane is heavier than air, install propane gas detectors low in a room. Inspect the detectors per the manufacturer's instructions.

Natural Gas—Adequate ventilation is mandatory. Because natural gas rises, install natural gas detectors high in a room. Inspect the detectors per the manufacturer's instructions.

Gas fuel leaks. Explosive fuel vapors can cause severe injury or death. Fuel leakage can cause an explosion. Check the LPG vapor or natural gas fuel system for leakage by using a soap and water solution with the fuel system test pressurized to 6–8 ounces per square inch (10–14 inches water column). Do not use a soap solution containing either ammonia or chlorine because both prevent bubble formation. A successful test depends on the ability of the solution to bubble.

LPG liquid withdrawal fuel leaks. Explosive fuel vapors can cause severe injury or death. Fuel leakage can cause an explosion. Check the LPG liquid withdrawal fuel system for leakage by using a soap and water solution with the fuel system test pressurized to at least 90 psi (621 kPa). Do not use a soap solution containing either ammonia or chlorine because both prevent bubble formation. A successful test depends on the ability of the solution to bubble.

6.2.1 Gas Lines

Never use fuel piping to ground electrical equipment. The gas supplier is responsible for installation, repair, and alteration to gas piping.

Line type

Use Schedule 40 black-iron pipe for gas piping. Copper tubing may be used if the fuel does not contain hydrogen sulfide or other ingredients that react chemically with copper.

Line size

Size piping according to the requirements of the equipment. Refer to the generator set specification sheet or the dimension drawing for detailed information on your system. In addition to the actual fuel consumption, consider the following pressure loss factors:

- Pipe length
- Other appliances on the same fuel supply
- Number of fittings

Flexible connections

Rigid-mount the piping but protect it from vibration. Use flexible connections spanning a minimum of 152 mm (6 in.) between the stationary piping and the engine fuel inlet connection.

6.2.2 Gas Regulators

Gas regulators reduce high incoming fuel pressures to lower levels acceptable for engines. Refer to the generator set spec sheet for fuel supply pressures. Install a solenoid valve upstream from the gas regulator and the flexible fuel connector to prevent the accumulation of an explosive mixture of gas and air caused by leaks in the flexible connection or the gas regulator. The generator set installer normally wires the engine battery-powered solenoid valve to the engine starting controls to open the valve when the engine cranks or runs.

For UL compliance, the fuel solenoid valves are needed per UL 2200, Section 35.3.2.2.1.

The typical gas system uses two gas regulators:

- **Primary gas regulator.** Provides initial control of gas from the fuel supply. The primary gas regulator reduces the high pressure from a tank or transmission line to the low pressure required by the secondary gas regulator(s). Typically, the primary gas regulator is set at the higher pressure value when a range is given. The gas supplier typically provides the primary gas regulator, as conditions that dictate the type of gas regulator used vary depending on the method of supplying fuel. The supplier is also responsible for providing sufficient gas pressure to operate the primary gas regulator. Primary gas regulator must be vented to the outside if installed within any building.
- **Secondary gas regulator.** This low-pressure gas regulator is mounted on the engine and limits the maximum inlet pressure to the engine. The engine operates satisfactorily at the lower pressure value when a range is given, but these lower pressures may result in poor response to load changes or a lack of power if the primary gas regulator is not near the engine.

Modification for fuel type

Many gas regulators are compatible with both natural gas and LP gas. Typically, the user installs the spring and retainer in the gas regulator when connecting to natural gas and removes it from the gas regulator when connecting to LP vapor gas. Refer to the appropriate generator set's operation manual and/or the decal attached to the generator set for information regarding spring/adjustment screw usage for specific models. Some models may require new diaphragm kits and/or inverting the gas regulator when changing fuel type.

Rating change

Converting the fuel will change the generator set rating. See the generator set specification sheet for ratings with natural gas and LP. Order a new nameplate with the updated rating and fuel information from an authorized distributor/dealer, if necessary. Provide the following information from the original nameplate:

- Model number
- Spec number
- Serial number
- Fuel (original and new)
- kW
- kVA
- Amps
- Volts
- Hz

Attach the new nameplate over the old one. Do NOT cover the UL listing information on the old nameplate.



Installation position for fuel type

The gas regulator functions normally pointing downward for both natural gas and LP gas. If only natural gas fuel is used, the gas regulator should be installed pointing upward.

Pressure testing

Some gas regulators provide for installation of a pressure gauge to test inlet and outlet pressures. If no such provision is available, install pipe tees in the fuel line to test pressure and use pipe plugs to plug unused openings.

6.3 LP Fuel Systems

 WARNING	Explosive fuel vapors. Can cause severe injury or death. Use extreme care when handling, storing, and using fuels.
 	

The fuel system. Explosive fuel vapors can cause severe injury or death. Vaporized fuels are highly explosive. Use extreme care when handling and storing fuels. Store fuels in a well-ventilated area away from spark-producing equipment and out of the reach of children. Never add fuel to the tank while the engine is running because spilled fuel may ignite on contact with hot parts or from sparks. Do not smoke or permit flames or sparks to occur near sources of spilled fuel or fuel vapors. Keep the fuel lines and connections tight and in good condition. Do not replace flexible fuel lines with rigid lines. Use flexible sections to avoid fuel line breakage caused by vibration. Do not operate the generator set in the presence of fuel leaks, fuel accumulation, or sparks. Repair fuel systems before resuming generator set operation.

Explosive fuel vapors can cause severe injury or death. Take additional precautions when using the following fuels:

Propane (LPG)—Adequate ventilation is mandatory. Because propane is heavier than air, install propane gas detectors low in a room. Inspect the detectors per the manufacturer's instructions.

Gas fuel leaks. Explosive fuel vapors can cause severe injury or death. Fuel leakage can cause an explosion. Check the LPG vapor or natural gas fuel system for leakage by using a soap and water solution with the fuel system test pressurized to 6–8 ounces per square inch (10–14 inches water column). Do not use a soap solution containing either ammonia or chlorine because both prevent bubble formation. A successful test depends on the ability of the solution to bubble.

LPG liquid withdrawal fuel leaks. Explosive fuel vapors can cause severe injury or death. Fuel leakage can cause an explosion. Check the LPG liquid withdrawal fuel system for leakage by using a soap and water solution with the fuel system test pressurized to at least 90 psi (621 kPa). Do not use a soap solution containing either ammonia or chlorine because both prevent bubble formation. A successful test depends on the ability of the solution to bubble.

Fuel characteristics

LP fuel exists as a vapor and a liquid in pressurized tanks. Since LP fuel does not deteriorate in storage, a large supply of fuel can be kept onsite indefinitely for operation during emergency conditions. This makes LP gas ideal for applications with uninterrupted (onsite) fuel supply requirements.

Fuel mixture

LP gas is propane, butane, or a mixture of the two gases. The ratio of butane to propane is especially important when the fuel flows from a large outdoor tank. A fuel supplier may fill the tank in the warm summer months with a mixture composed mainly of butane; however, this mixture may not provide sufficient vaporized pressure at cold temperatures to start and operate the engine. A local fuel supplier is likely to be the best source of information on what size tank is necessary to provide adequate fuel vapor.

The fuel mixture and vaporization pressure at the anticipated temperatures influence the selection of gas regulator equipment. Pure butane gas has little or no vaporization pressure in temperatures below 4°C (40°F). Even at 21°C (70°F), the pressure is approximately 124 kPa (18 psi). Some primary gas regulators do not operate at tank pressures below 207 kPa (30 psi) while others operate at incoming pressures as low as 20.7-34.5 kPa (3-5 psi).

Fuel consumption and tank size

Since LP fuel is supplied in pressurized tanks in liquid form, it must be converted to a vapor state before being introduced into the carburetor. The amount of vapor contained in 3.8 L (1.0 gal.) of liquid (LP) fuel is:

Butane Gas	0.88 m ³ (31.26 cu. ft.)
Propane Gas	1.03 m ³ (36.39 cu. ft.)

See the generator set specification sheets for fuel consumption at different loads, and contact your fuel supplier for information regarding tank sizes.

System types

Single-source gas fuel systems include LP gas vapor-withdrawal and LP gas liquid-withdrawal.

6.3.1 LP Gas Liquid-Withdrawal Systems

LP liquid-withdrawal fuel systems are available for generator sets but are not recommended for automatic standby service. With liquid-withdrawal systems, liquid LP at 1034-1379 kPa (150-200 psi) flows to the engine. A combination of converters (vaporizers) and gas regulators then reduces the pressure to a usable level.

In Figure 56, a converter (a combination of a vaporizer and primary and secondary gas regulators) changes the liquid to vapor using heat from the engine's cooling system. For a period following startup, a liquid-withdrawal system may be unable to vaporize enough fuel for an engine running under load until the engine reaches operating temperature. The engine needs time to warm sufficiently to provide adequate heat to vaporize the fuel.

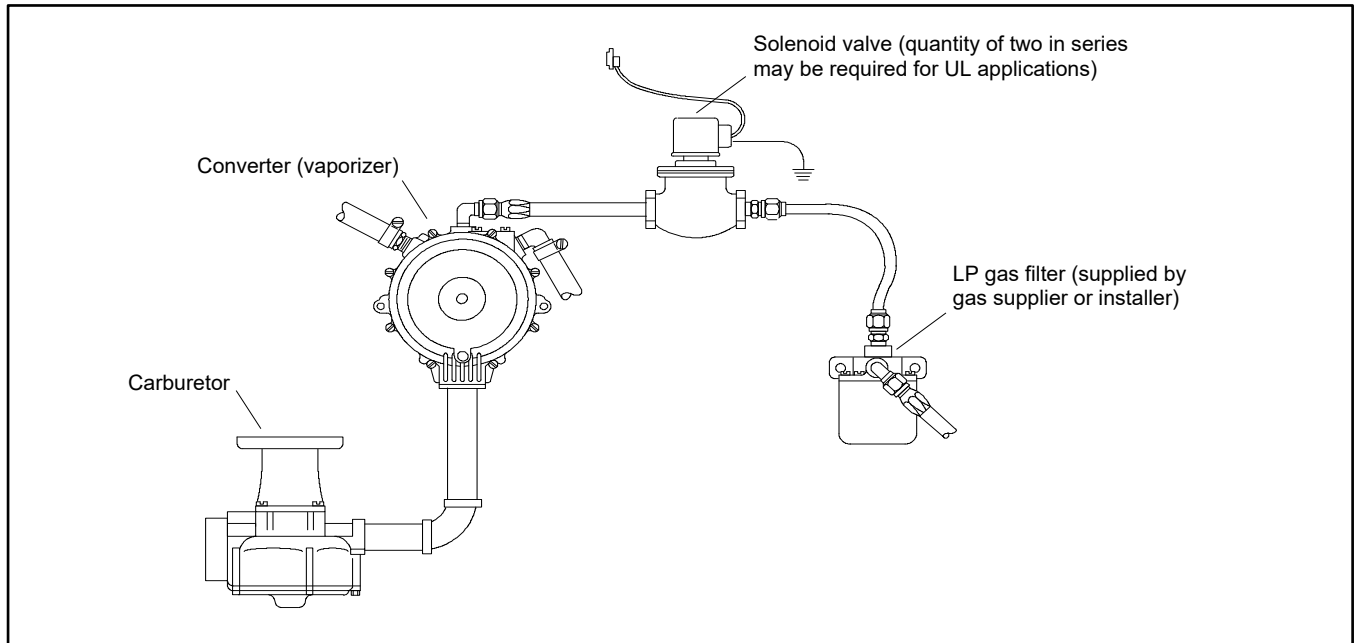

Figure 56 LP Gas Liquid Withdrawal System

Some codes prohibit gas fuel pressurization greater than 34.5 kPa (5 psi) inside buildings. This might preclude the use of a liquid-withdrawal system. To ensure code compliance, converters are sometimes located outside the building housing the generator set. However, the great length of pipe between the converter and the carburetor does not allow sufficient heat buildup and heat retention to maintain the fuel in its vapor state, which can cause startup problems.

6.3.2 LP Gas Vapor-Withdrawal Systems

A vapor-withdrawal system draws on the fuel vapor that collects in the space above the liquid fuel. Consider the following during installation:

- Generally, allow 10%-20% of tank capacity for fuel expansion from a liquid to a vapor state. The liquid level in LP gas tanks must never exceed 90% of the tank capacity.
- Maintain air temperature surrounding the tank high enough to vaporize the liquid fuel.

Applications in colder climates may require an independent heat source to increase natural vaporization within the tank. Withdraw liquid fuel and vaporize it in an electrically heated, engine water jacket-heated, or LP gas-heated vaporizer. Figure 57 shows the components of the vapor-withdrawal system used in a typical stationary application. The LP gas regulator is typically installed in the inverted position (pointing downward).

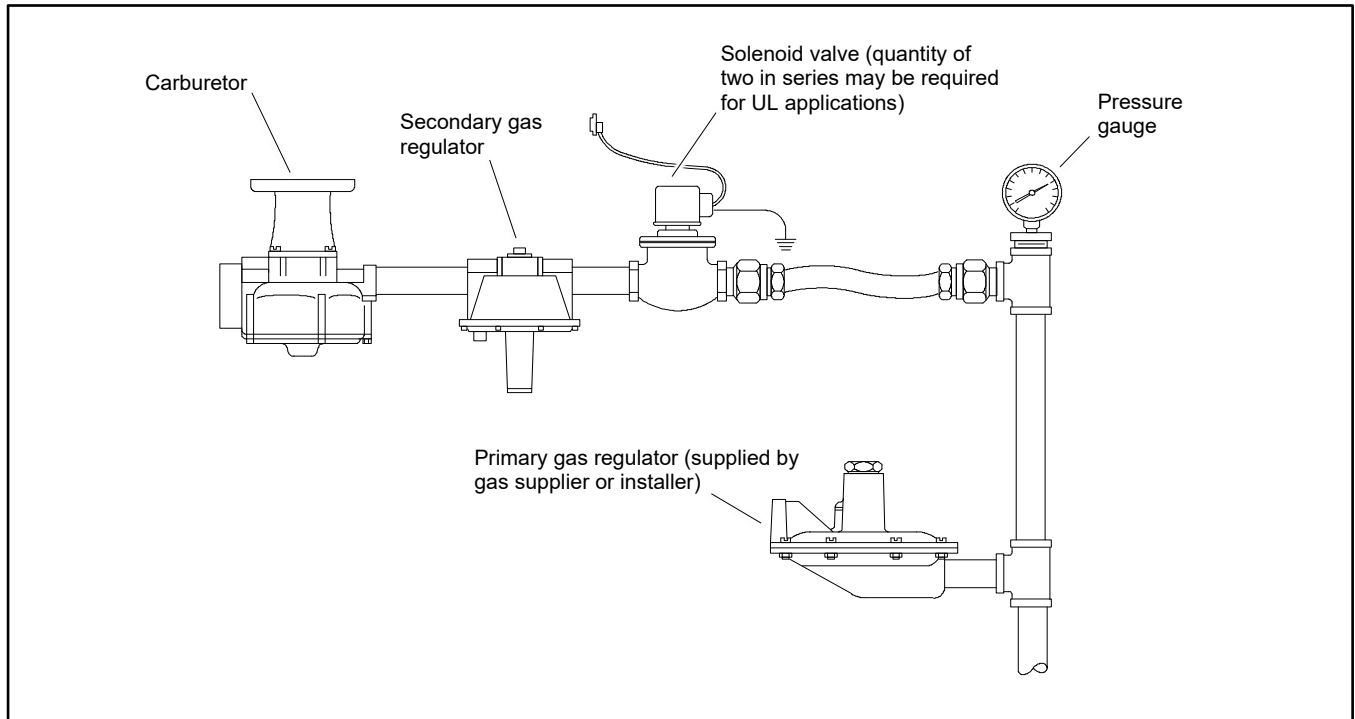



Figure 57 Typical LP Gas Vapor-Withdrawal System

6.4 Natural Gas Systems

⚠ WARNING	Explosive fuel vapors. Can cause severe injury or death. Use extreme care when handling, storing, and using fuels.
	

The fuel system. Explosive fuel vapors can cause severe injury or death. Vaporized fuels are highly explosive. Use extreme care when handling and storing fuels. Store fuels in a well-ventilated area away from spark-producing equipment and out of the reach of children. Never add fuel to the tank while the engine is running because spilled fuel may ignite on contact with hot parts or from sparks. Do not smoke or permit flames or sparks to occur near sources of spilled fuel or fuel vapors. Keep the fuel lines and connections tight and in good condition. Do not replace flexible fuel lines with rigid lines. Use flexible sections to avoid fuel line breakage caused by vibration. Do not operate the generator set in the presence of fuel leaks, fuel accumulation, or sparks. Repair fuel systems before resuming generator set operation.

Explosive fuel vapors can cause severe injury or death. Take additional precautions when using the following fuels:

Gas fuel leaks. Explosive fuel vapors can cause severe injury or death. Fuel leakage can cause an explosion. Check the LPG vapor or natural gas fuel system for leakage by using a soap and water solution with the fuel system test pressurized to 6–8 ounces per square inch (10–14 inches water column). Do not use a soap solution containing either ammonia or chlorine because both prevent bubble formation. A successful test depends on the ability of the solution to bubble.

The utility supplies natural gas in a vapor state. A natural gas fuel system consists of the same basic components and operates with the same general sequence as LP gas vapor-withdrawal systems. See Figure 58 and Figure 59. Note that when the heat content of the fuel falls below 1000 Btu, as it does with sewage-derived and some other natural gas fuels, the generator set will not produce its rated power. The natural gas regulator is typically installed in the upright position (pointing upward).

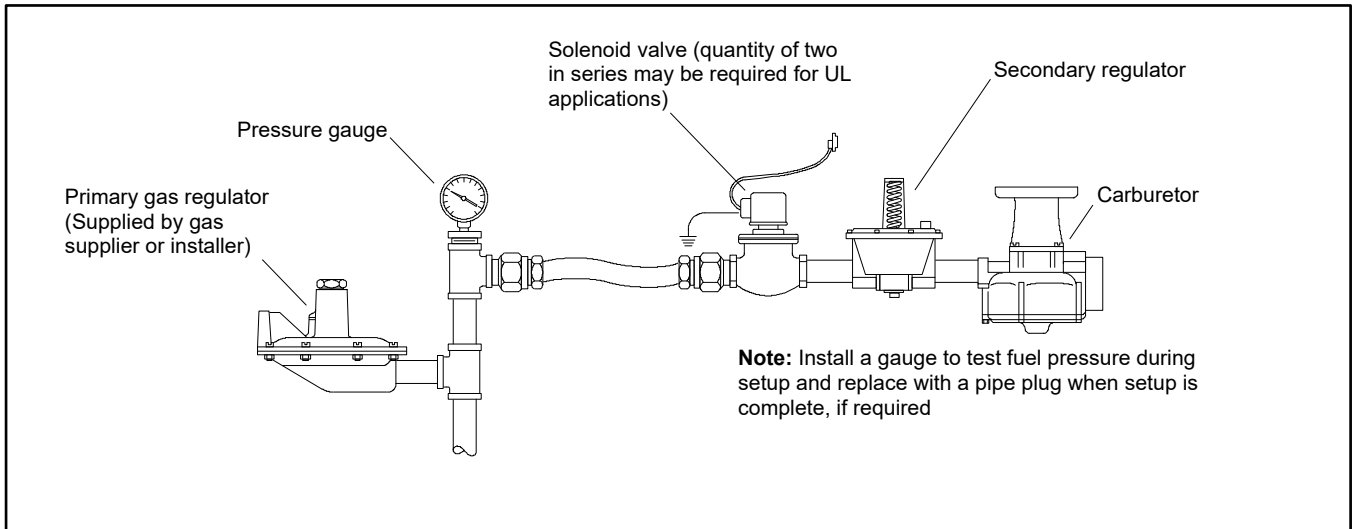

Figure 58 Natural Gas Fuel System with Pressure Gauge

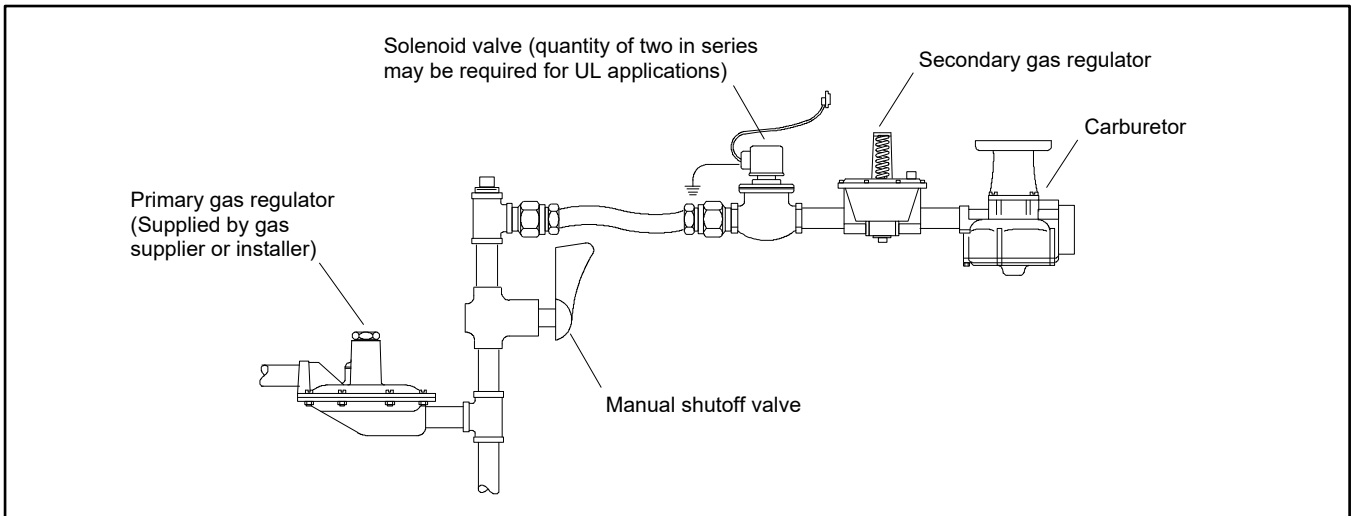

Figure 59 Natural Gas Fuel System without Pressure Gauge and with Manual Shutoff Valve

6.5 Combination Systems

Combination fuel source systems include:

- Natural gas and LP gas

6.5.1 Combination Natural Gas and LP Gas

Some applications use natural gas as the main fuel and LP gas as the emergency fuel when natural gas is not available.

The natural gas and LP gas, liquid withdrawal system uses a converter (vaporizer) to change the LP liquid to gas vapor. A pressure switch on the primary fuel source closes when fuel pressure drops, which energizes a relay that closes the primary fuel solenoid and opens the secondary or emergency fuel solenoid. A separate LP gas load adjustment valve ensures the right fuel-to-air mixture in the carburetor. The load adjustment valve is located in-line between the converter (vaporizer) and the carburetor. See Figure 60.

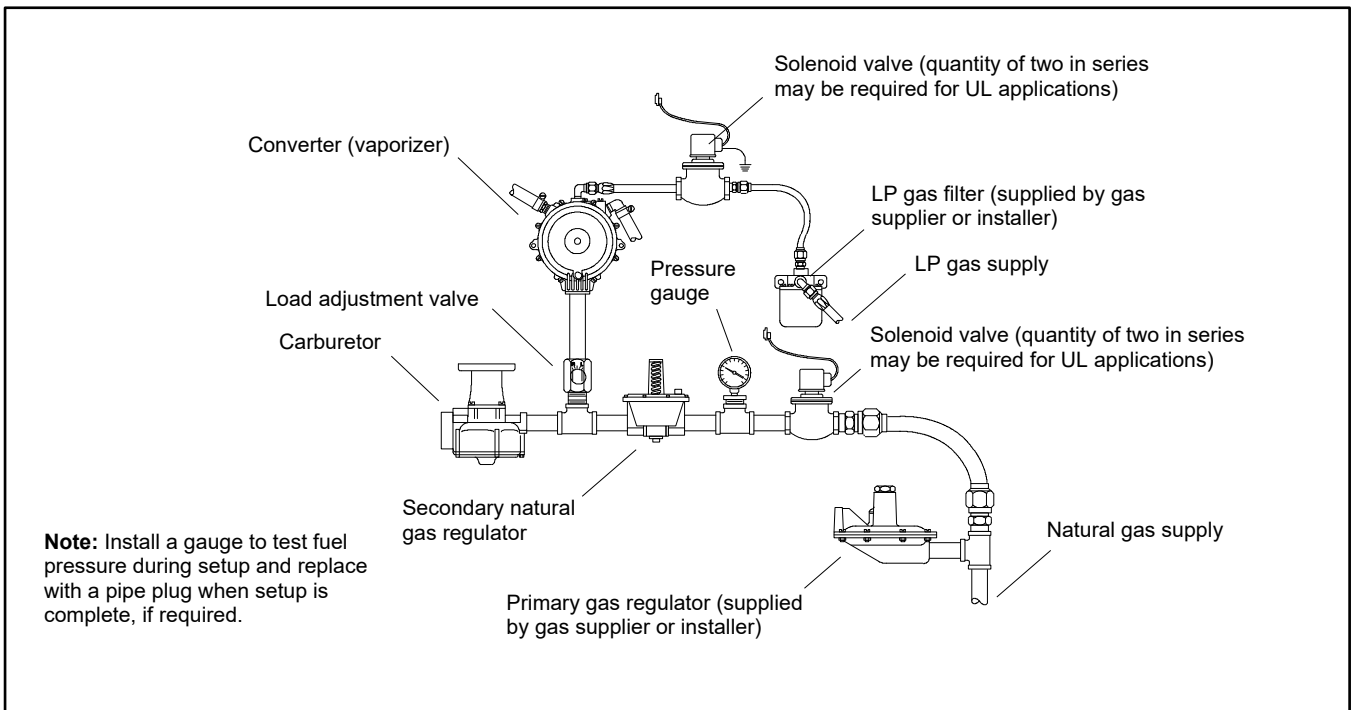

Figure 60 Natural Gas and LP Gas System, Liquid Withdrawal

The natural gas and LP gas, vapor withdrawal system contains a separate secondary gas regulator and solenoid valve for each fuel. The LP gas regulator typically mounts in the inverted position. A pressure switch on the primary fuel source closes when fuel pressure drops, which energizes a relay that closes the primary fuel solenoid and opens the secondary or emergency fuel solenoid. A separate LP gas load adjustment valve ensures the right fuel-to-air mixture in the carburetor.

The load adjustment valve is located in-line between the secondary gas regulator and the carburetor. See Figure 61.

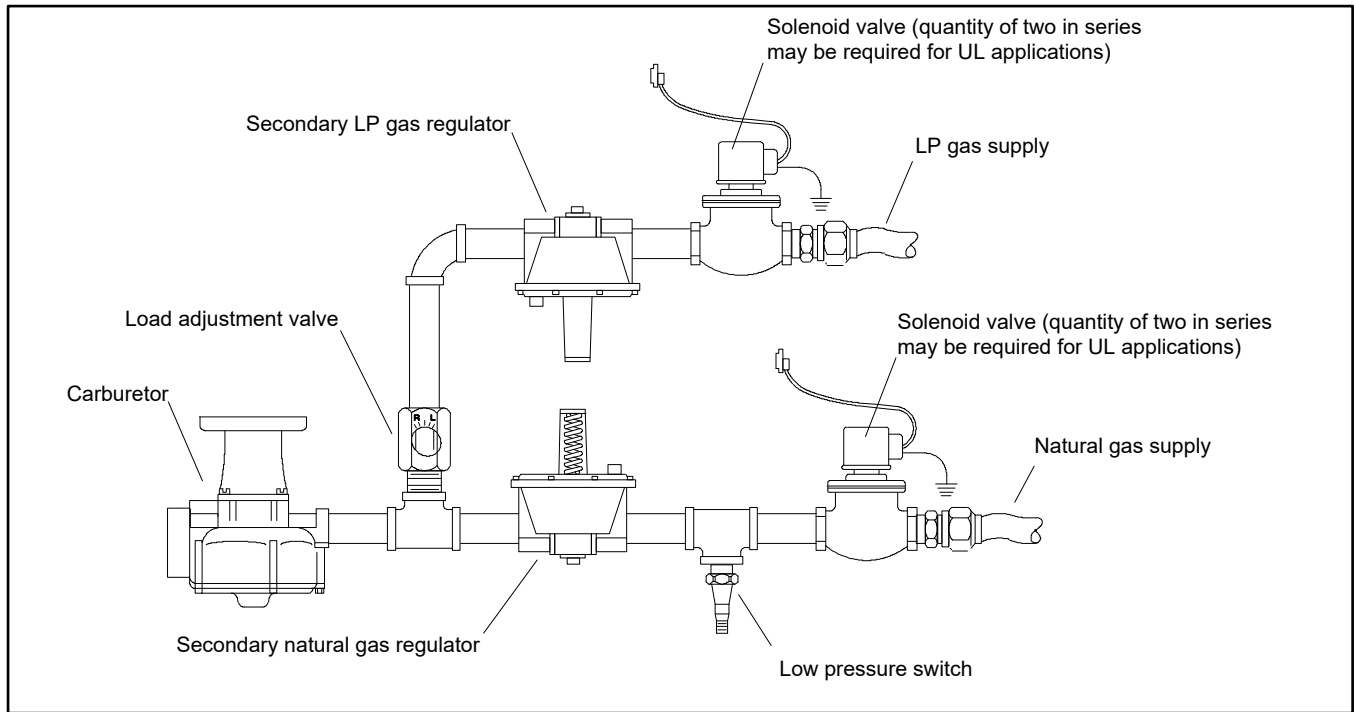

Figure 61 Natural Gas and LP Gas System, Vapor Withdrawal

6.5.2 Automatic Changeover Dual Fuel Systems with Reset Box

A changeover fuel system kit provides automatic changeover from natural gas to LPG vapor. The primary and secondary fuels each have a fuel solenoid valve. The primary fuel is natural gas; the secondary fuel is LPG vapor. Before starting, both fuel solenoid valves are closed. When the generator set starts, the primary fuel solenoid valve opens. The primary fuel line has a pressure switch in series with a relay connected to the start/run circuit.

When the primary fuel pressure drops, a relay opens the secondary fuel solenoid valve and closes the primary fuel solenoid valve. When the primary fuel pressure rises the generator set uses the primary fuel. Contact an authorized service distributor/dealer for kit availability.

Emissions certified models use a single direct acting electronic pressure regulator (DEPR) for both fuels.

If unit is built as a dual fuel configuration but only installed as a single fuel (i.e. NG fuel is hooked up to the unit but LP is not), a metallic plug must be installed in the non-used fuel inlet.

Dual Fuel Operation

The automatic changeover dual fuel system includes an LPG indicator light and a reset switch. This LPG indicator light turns on when the NG fuel valve closes and the LPG fuel valve opens, indicating that the fuel source has switched. The reset switch resets the fuel source to natural gas. See the operation summary below.

When NG fuel is lost or insufficient

- NG fuel valve closes.
- LPG fuel valve opens.
- Indicator light turns on indicating the unit is running on LPG vapor.
- Low fuel pressure warning activates (due to loss of primary fuel supply).

The unit will return to NG fuel if:

- The reset switch is activated (separate box with a switch and light).

Note:

The reset switch can be activated while the unit is running.

- LPG fuel supply is lost or insufficient.

Note:

If NG fuel supply has still not returned, the unit will shut down due to not having an available fuel source.

- The generator set is shut down and restarted.
 - Utility returns.
 - Off button is manually pressed.
 - E-Stop is pressed.

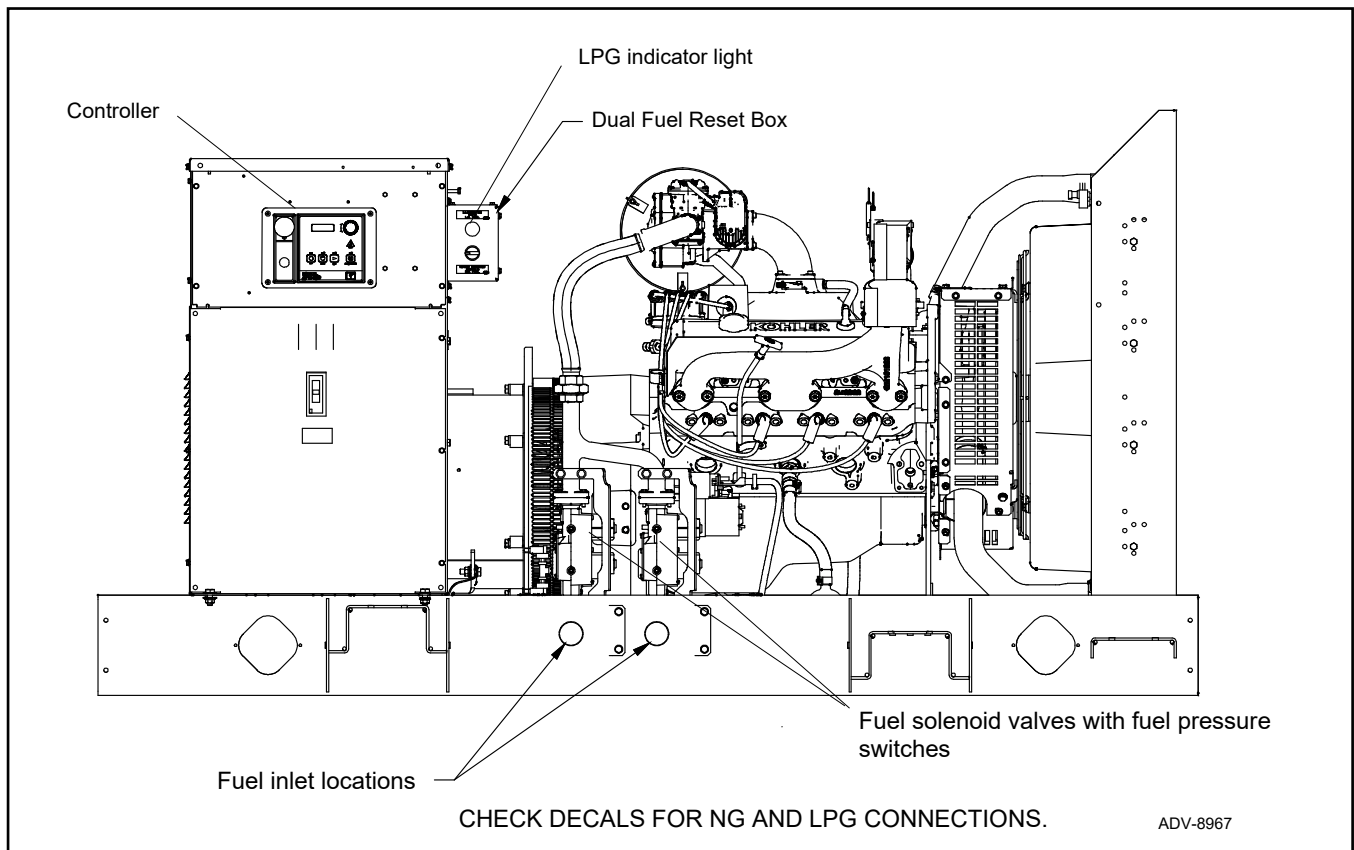

Figure 62 Dual Fuel System, KG40-KG60

6.6 Pipe Size Requirements for Gas Fuel Systems

The type of fuel, the distance it must travel from gas meter/tank to fuel shutoff solenoid, and the amount consumed by the engine must be considered when determining fuel line pipe size.

To find the correction necessary for the different specific gravity of the particular fuel used, refer to Figure 63.

Fuel	Specific Gravity	Correction Factor
Sewage Gas	0.55	1.040
Natural Gas	0.65	0.962
Air	1.00	0.775
Propane (LP)	1.50	0.633
Butane	2.10	0.535

Figure 63 Fuel Correction Factors

Figure 64 is based on gas pressures of 3.4 kPa (0.5 psi, 13.8 in. water column) or less and a pressure drop of 0.12 kPa (0.018 psi, 0.5 in. water column) with a 1.60 specific gravity and with a normal amount of restriction from fittings. Add 2.4 m (8 ft.) to the measured length for each 90° elbow to calculate the correct pipe size for a specific installation. Refer to the chart and follow the procedure outlined below.

Nominal Iron Pipe Size (IPS), In.	Internal IPS Diameter, mm (in.)	Length of Pipe, m (ft.)						
		3.0 (10)	6.1 (20)	9.1 (30)	12.2 (40)	15.2 (50)	18.3 (60)	21.3 (70)
		Fuel Consumption Value, m ³ /hr. (ft ³ /hr.)						
1/4	9.25 (0.364)	1.2 (43)	0.82 (29)	0.68 (24)	0.57 (20)	0.51 (18)	0.45 (16)	0.42 (15)
3/8	12.52 (0.493)	2.7 (95)	1.8 (65)	1.5 (52)	1.3 (45)	1.1 (40)	1.0 (36)	0.93 (33)
1/2	15.80 (0.622)	5.0 (175)	3.4 (120)	2.7 (97)	2.3 (82)	2.1 (73)	1.9 (66)	1.7 (61)
3/4	20.93 (0.824)	10.2 (360)	7.1 (250)	5.7 (200)	4.8 (170)	4.3 (151)	3.9 (138)	3.5 (125)
1	26.64 (1.049)	19.3 (680)	13.2 (465)	10.6 (375)	9.1 (320)	8.1 (285)	7.4 (260)	6.8 (240)
1 1/4	35.05 (1.380)	39.6 (1400)	26.9 (950)	21.8 (770)	18.7 (660)	16.4 (580)	13.9 (490)	13.0 (460)
1 1/2	40.89 (1.610)	59.5 (2100)	41.3 (1460)	33.4 (1180)	28.0 (990)	25.5 (900)	22.9 (810)	21.2 (750)
2	52.50 (2.469)	111.9 (3950)	77.9 (2750)	62.3 (2200)	53.8 (1900)	47.6 (1680)	43.0 (1520)	39.6 (1400)
2 1/2	62.71 (2.469)	178.4 (6300)	123.2 (4350)	99.7 (3520)	85.0 (3000)	75.0 (2650)	68.0 (2400)	63.7 (2250)
3	77.93 (3.068)	311.5 (11000)	218.0 (7700)	177.0 (6250)	150.0 (5300)	134.6 (4750)	121.8 (430)	110.4(3900)
4	102.26 (4.026)	651.2 (23000)	447.4 (15800)	362.5 (12800)	308.7 (10900)	274.7 (9700)	249.1 (8800)	229.4 (8100)

Nominal Iron Pipe Size (IPS), In.	Internal IPS Diameter, mm (in.)	Length of Pipe, m (ft.)						
		24.4 (80)	27.4 (90)	30.5 (100)	38.1 (125)	45.7 (150)	53.3 (175)	61.0 (200)
		Fuel Consumption Value, m ³ /hr. (ft ³ /hr.)						
1/4	9.25 (0.364)	0.39 (14)	0.37 (13)	0.34 (12)	0.31 (11)	0.28 (10)	0.25 (9)	0.23 (8)
3/8	12.52 (0.493)	0.88 (31)	0.82 (29)	0.76 (27)	0.68 (24)	0.62 (22)	0.57 (20)	0.54 (19)
1/2	15.80 (0.622)	1.6 (57)	1.5 (53)	1.4 (50)	1.2 (44)	1.1 (40)	1.0 (37)	0.99 (35)
3/4	20.93 (0.824)	3.3 (118)	3.1 (110)	2.9 (103)	2.6 (93)	2.4 (84)	2.2 (77)	2.0 (72)
1	26.64 (1.049)	6.2 (220)	5.8 (205)	5.5 (195)	5.0 (175)	4.5 (160)	4.1 (145)	3.8 (135)
1 1/4	35.05 (1.380)	13.0 (460)	12.2 (430)	11.3 (400)	10.2 (360)	9.2 (325)	8.5 (300)	7.9 (280)
1 1/2	40.89 (1.610)	19.5 (690)	18.4 (650)	17.6 (620)	15.6 (550)	14.2 (500)	13.0 (460)	12.2 (430)
2	52.50 (2.067)	36.8 (1300)	34.5 (1220)	32.6 (1150)	28.9 (1020)	26.9 (950)	24.1 (850)	22.7 (800)
2 1/2	62.71 (2.469)	58.1 (2050)	55.2 (1950)	52.4 (1850)	46.7 (1650)	42.5 (1500)	38.8 (1370)	36.2 (1280)
3	77.93 (3.068)	104.8 (3700)	97.7 (3450)	92.0 (3250)	83.5 (2950)	75.0 (2650)	69.4 (2450)	64.6 (2280)
4	102.26 (4.026)	212.4 (7500)	203.9 (7200)	189.7 (6700)	169.9 (6000)	155.7 (5500)	141.6 (5000)	130.3 (4600)

Note: When the fuel has a specific gravity of 0.7 or less no correction factor is necessary – use this table without a correction factor.

Figure 64 Maximum Flow Capacity of Pipe in Cubic Meters (Cubic Feet) of Gas per Hour

1. Refer to the fuel consumption on the generator set specification sheet. Note type of fuel used, generator set application rating, and the m^3/hr . (ft^3/hr .) consumption at 100% load.

Example:

80 kW, propane gas, 60 Hz standby rating = $12.0 \text{ m}^3/\text{hr}$. ($425 \text{ ft}^3/\text{hr}$.)

2. Refer to the Fuel Correction Factors in Figure 63. Locate the correction factor for specific gravity of the selected fuel.

When the fuel has a specific gravity of 0.7 or less no correction factor is necessary – use Figure 64 without a correction factor.

Example:

propane gas specific gravity = 1.50 fuel correction factor = 0.633.

3. Divide the consumption value from step 1 by the correction factor from step 2.

Example:

$12.0 \text{ m}^3/\text{hr}$. ($425 \text{ ft}^3/\text{hr}$.) divided by 0.633 = $19.0 \text{ m}^3/\text{hr}$. ($671 \text{ ft}^3/\text{hr}$.)

4. Determine the length of pipe between the gas meter/tank and the fuel shutoff solenoid at the generator set.

Example: 34.7 m (114 ft.).

5. Find the value closest to pipe length in the Length of Pipe column in.

Example: 38.1 m (125 ft.).

Example:

At $28.9 \text{ m}^3/\text{hr}$. ($1020 \text{ ft}^3/\text{hr}$.) the pipe size = 2 in. IPS.

6. Move vertically down the table in Figure 64 from the determined value in Length of Pipe column.

Example: 38.1 m (125 ft.)

Stop at the value that is equal to or greater than corrected consumption value from step 3.

Example:

$28.9 \text{ m}^3/\text{hr}$. ($1020 \text{ ft}^3/\text{hr}$.)

7. Move to the left column from the value in step 6 to determine the correct pipe size.



Notes

Section 7. Electrical System

Before installing the generator set, provide for electrical connections through conduit to the transfer switch and other accessories for the generator set. Carefully install the selected generator set accessories. Route wiring to the generator set through flexible connections. Regarding the application of bushings and grommets for the entry of wiring, use Class 1 wiring methods for field wiring connections to a Class 2 circuit. Comply with applicable national and local codes when installing a wiring system.

AC circuit protection

All AC circuits must include circuit breaker or fuse protection. Select a circuit breaker for up to 125% of the rated generator set output current. The circuit breaker must open all ungrounded conductors. The circuit breaker or fuse must be mounted within 7.6 m (25 ft.) of the alternator output terminals.

 WARNING	<p>Accidental starting. Can cause severe injury or death.</p> <p>Disconnect the battery cables before working on the generator set. Remove the negative (-) lead first when disconnecting the battery. Reconnect the negative (-) lead last when reconnecting the battery.</p>
	

Disabling the generator set. Accidental starting can cause severe injury or death. Before working on the generator set or equipment connected to the set, disable the generator set as follows: (1) Move the generator set master switch to the OFF position. (2) Disconnect the power to the battery charger. (3) Remove the battery cables, negative (-) lead first. Reconnect the negative (-) lead last when reconnecting the battery. Follow these precautions to prevent starting of the generator set by an automatic transfer switch, remote start/stop switch, or engine start command from a remote computer.

(Decision-Maker® 3+ and 550 Controllers)

Disabling the generator set. Accidental starting can cause severe injury or death. Before working on the generator set or equipment connected to the set, disable the generator set as follows: (1) Press the generator set off/reset button to shut down the generator set. (2) Disconnect the power to the battery charger, if equipped. (3) Remove the battery cables, negative (-) lead first. Reconnect the negative (-) lead last when reconnecting the battery. Follow these precautions to prevent the starting of the generator set by the remote start/stop switch.



(APM402, APM603, RDC2, and Decision-Maker® 3000, 3500, and 6000 Controllers)

Disabling the generator set. Accidental starting can cause severe injury or death. Before working on the generator set or equipment connected to the set, disable the generator set as follows: (1) If the controller is not already in the MAN (manual) mode, press the Controller Mode button and then press the MAN mode button. (2) If the generator set is running, press and hold the Manual-Stop button for at least 2 seconds to stop the generator set. (3) Press the Controller Mode button and then press the controller Off mode button. (4) Disconnect the power to the battery charger, if equipped. (5) Remove the battery cables, negative (-) lead first. Reconnect the negative (-) lead last when reconnecting the battery. Follow these precautions to prevent the starting of the generator set by the remote start/stop switch.

(Decision-Maker® 8000 Controller)

Disabling the generator set. Accidental starting can cause severe injury or death. Before working on the generator set or equipment connected to the set, disable the generator set as follows: (1) Shut down the generator set. (2) Place the controller in Out of Service mode. (3) Press the emergency stop button. (4) Disconnect the power to the battery charger, if equipped. (5) Remove the battery cables, negative (-) lead first. Reconnect the negative (-) lead last when reconnecting the battery. Follow these precautions to prevent the starting of the generator set by the remote start/stop switch.

(APM802 Controller)

 DANGER	<p>Hazardous voltage. Moving parts. Will cause severe injury or death.</p> <p>Operate the generator set only when all guards and electrical enclosures are in place.</p>
	

Short circuits. Hazardous voltage/current will cause severe injury or death. Short circuits can cause bodily injury and/or equipment damage. Do not contact electrical connections with tools or jewelry while making adjustments or repairs. Remove all jewelry before servicing the equipment.

7.1 Generator Set Voltage Reconnection

To change the voltage of 10- or 12-lead generator sets, use the procedure shown in the operation manual containing the respective controller setup. Adjust the governor and voltage regulator for frequency changes. Consult the generator set service manual for frequency adjustment information.

Voltage reconnection.

Affix a notice to the generator set after reconnecting the set to a voltage different from the voltage on the nameplate. Order voltage reconnection decal 246242 from an authorized service distributor/ dealer.

Equipment damage

Verify that the voltage ratings of the transfer switch, line circuit breakers, and other accessories match the selected line voltage.

Reconnect the generator set stator leads to change the output phase or voltage. Reference the appropriate voltage reconnection drawing in the respective Wiring Diagram Manual.

Follow the safety precautions at the front of this manual and in the text and observe National Electrical Code (NEC) guidelines.

7.2 Electrical Connections

Several electrical connections must be made between the generator set and other components of the system for proper operation. Because of the large number of accessories and possible combinations, this manual does not address specific applications. Refer to the submittal catalog accessory drawings and wiring diagrams for connection and location. Most field-installed accessory kits include installation instructions.

For customer-supplied wiring, select the wire temperature rating in Figure 65 based upon the following criteria:

- Select row 1, 2, 3, or 4 if the circuit rating is 110 amperes or less or requires #1 AWG (42.4 mm²) or smaller conductors.
- Select row 3 or 4 if the circuit rating is greater than 110 amperes or requires #1 AWG (42.4 mm²) or larger conductors.

Comply with applicable national and local codes when installing a wiring system.

Row	Temp. Rating	Copper (Cu) Only	Cu/Aluminum (Al) Combinations	Al Only
1	60°C (140°F) or 75°C (167°F)	Use No. * AWG, 60°C wire or use No. * AWG, 75°C wire	Use 60°C wire, either No. * AWG Cu, or No. * AWG Al or use 75°C wire, either No. * AWG Cu or No. * AWG Al	Use 60°C wire, No. * AWG or use 75°C wire, No. * AWG
2	60°C (140°F)	Use No. * AWG, 60°C wire	Use 60°C wire, either No. * AWG Cu or No. * AWG Al	Use 60°C wire, No. * AWG
3	75°C (167°F)	Use No. *[AWG, 75°C wire	Use 75°C wire, either No. *+ AWG Cu or No. *+ AWG Al	Use 75°C wire, No.*+ AWG
4	90°C (194°F)	Use No. *[AWG, 90°C wire	Use 90°C wire, either No. *+ AWG Cu or No. *+ AWG Al	Use 90°C wire, No.*+ AWG
<p>* The wire size for 60°C (140°F) wire is not required to be included in the marking. If included, the wire size is based on ampacities for the wire given in Table 310-16 of the National Electrical Coder, in ANSI/NFPA 70, and on 115% of the maximum current that the circuit carries under rated conditions. The National Electrical Coder is a registered trademark of the National Fire Protection Association, Inc.</p> <p>+ Use the larger of the following conductors: the same size conductor as that used for the temperature test or one selected using the guidelines in the preceding footnote.</p>				

Figure 65 Terminal Markings for Various Temperature Ratings and Conductors

7.3 Load Lead Connections

Feed load leads to the generator junction box from one of several different areas. Generator sets rated 300 kW and below commonly use the bottom entry where conduit is stubbed up into the junction box from the concrete slab. Other methods include flexible conduit roughed into the sides or top of the junction box. When using flexible conduit, do not block the front or rear of the controller. See Figure 66

Use a minimum of 13 mm (0.5 in.) spacing between the conduit bushing and any uninsulated live parts in the junction box. All conduit openings in the junction box must be made such that no metal particles including drill chips contaminate the components in the junction box.

Generator sets larger than 300 kW have the junction box mounted on the rear of the generator set. Larger sets may have oversized junction boxes supplied as an option or to accommodate bus bar connections. Refer to the generator set dimension drawing and/or the electrical contractor prints for detailed information including stub-up area recommendations.

The four bus bars contained in the optional bus bar kits simplify the connection process by offering a neutral bus bar in addition to the three load bars. Optional bus lugs offer an array of terminal and wire connections.

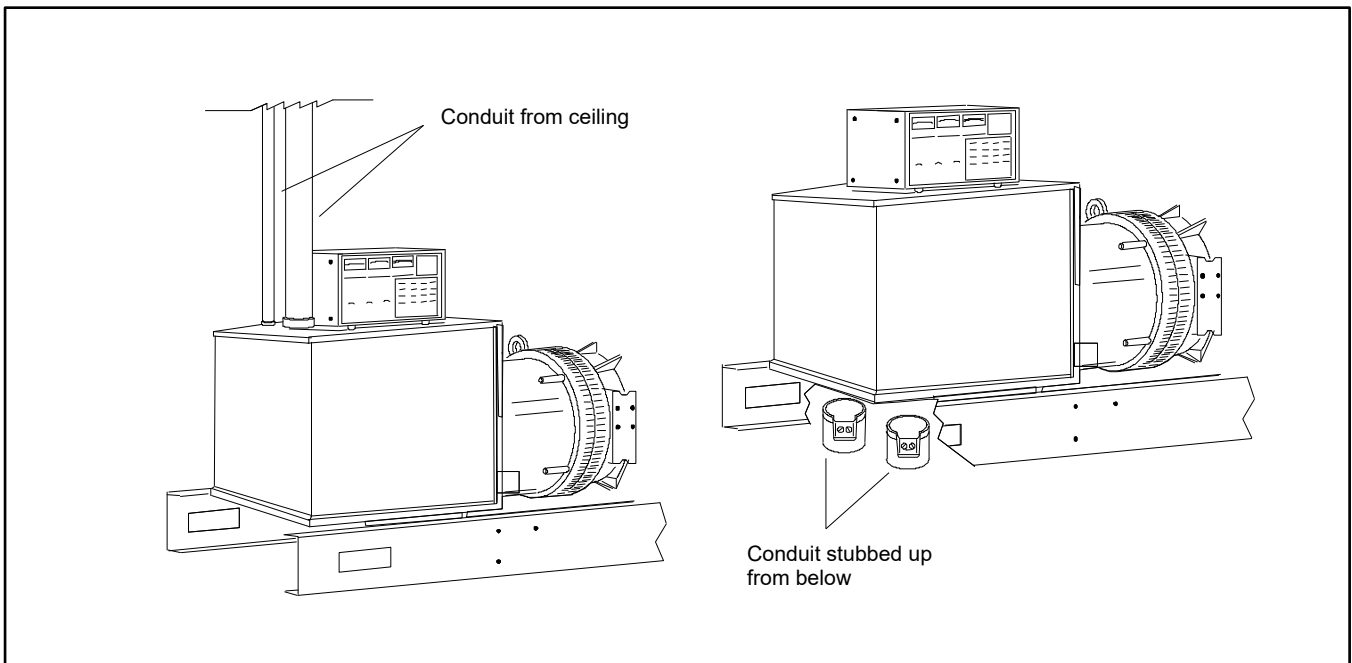

Figure 66 Typical Load Lead Connection

7.4 Grounding and Grounded Conductor (Neutral) Connections

Connect the electrical system grounding conductor to the equipment grounding connector on the alternator. See Figure 67. Depending upon code requirements, the grounded conductor (neutral) connection is typically grounded.

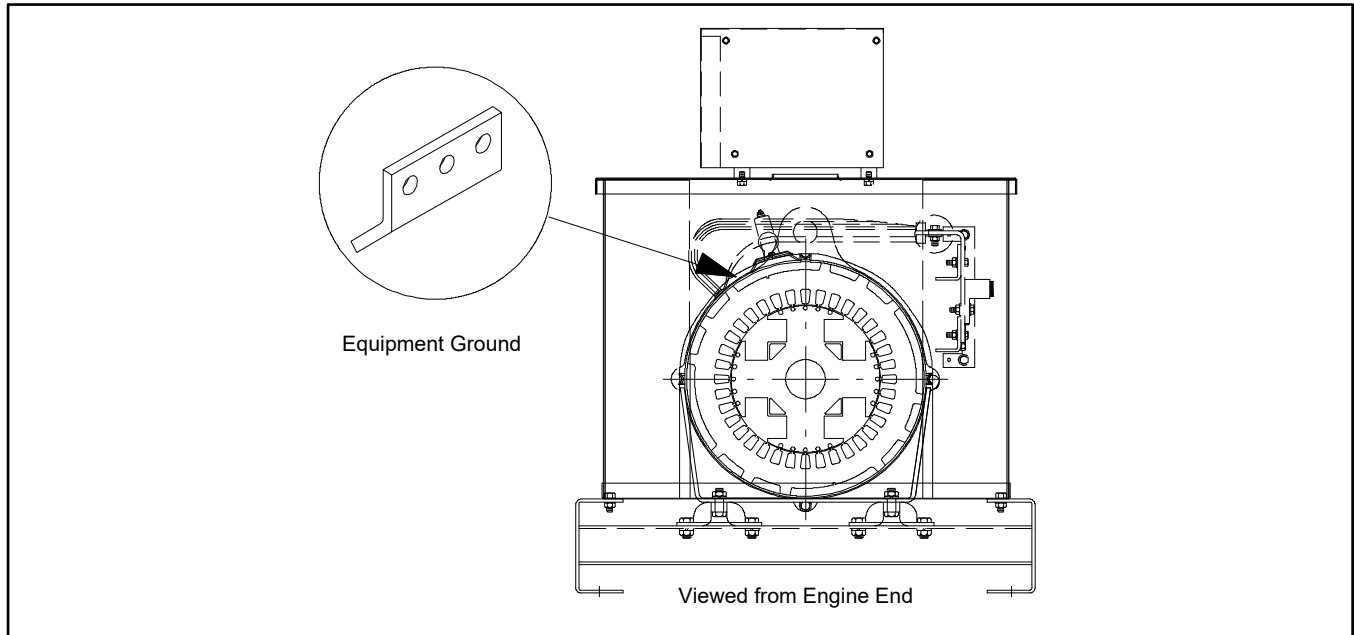

Figure 67 Generator Set Equipment Grounding Connection

Ungrounded neutral connections use an insulated standoff (not supplied) to isolate the neutral connection from the grounding connection. For grounding lug selection, see Figure 68.

The four bus bars contained in the optional bus bar kits simplify the connection process by offering a neutral bus bar in addition to the three load bars. Optional bus lugs offer an array of terminal and wire connections.

Generator sets are typically shipped from the factory with the neutral attached to the alternator in the junction box for safety reasons per NFPA 70. At installation, the neutral can remain grounded at the alternator or be lifted from the grounding stud and isolated if the installation requires an ungrounded neutral connection at the generator set. The generator set will operate properly in either configuration.

Various regulations and site configurations including the National Electrical Coder (NEC), local codes, and the type of transfer switch used in the application determine the grounding of the neutral at the generator set.

Allowable Ampacity, Amps	Min. Size of Equipment Copper Grounding Conductor, AWG or Kcmil
20	12
60	10
90	8
100	8
150	6
200	6
300	4
400	3
500	1
600	1
800	1/0
1000	2/0
1200	3/0
1600	4/0
2000	250
2500	350
3000	400
4000	500
5000	700
6000	800

Figure 68 Grounding Lug Selection

7.5 Terminal Connector Torque

Use torque values shown in Figure 69 or Figure 70 for terminal connectors. Refer to UL 486A-486B and UL 486E for information on terminal connectors for aluminum and/or copper conductors. See the previous section, "Electrical Connections," for information on temperature rating of the customer-supplied wire. Comply with applicable national and local codes when installing a wiring system.

Socket Size Across Flats, mm (in.)		Tightening Torque, Nm (in.lb.)	
3.2	(1/8)	5.1	(45)
4.0	(5/32)	11.4	(100)
4.8	(3/16)	13.8	(120)
5.6	(7/32)	17.0	(150)
6.4	(1/4)	22.6	(200)
7.9	(5/16)	31.1	(275)
9.5	(3/8)	42.4	(375)
12.7	(1/2)	56.5	(500)
14.3	(9/16)	67.8	(600)

Note: For values of slot width or length not corresponding to those specified, select the largest torque value associated with the conductor size. Slot width is the nominal design value. Slot length is to be measured at the bottom of the slot.

Figure 69 Tightening Torque for Pressure Wire Connectors with Internal-Drive Socket-Head Screws

If a connector has a clamp screw such as a slotted, hexagonal head screw with more than one means of tightening, test the connector using both applicable torque values provided in Figure 70.

Wire Size for Unit Connection	Tightening Torque, Nm (in. lb.)			
	Slot Head 4.7 mm (No. 10) or Larger*		Hexagonal Head – External Drive Socket Wrench	
AWG, kcmil (mm ²)	Slot Width <1.2 mm (0.047 in.) Slot Length <6.4 mm (0.25 in.)	Slot Width > 1.2 mm (0.047 in.) Slot Length >6.4 mm (0.25 in.)	Split-Bolt Connectors	Other Connections
18-10 (0.82-5.3)	2.3 (20)	4.0 (35)	9.0 (80)	8.5 (75)
8 (8.4)	2.8 (25)	4.5 (40)	9.0 (80)	8.5 (75)
6-4 (13.3-21.2)	4.0 (35)	5.1 (45)	18.6 (165)	12.4 (110)
3 (26.7)	4.0 (35)	5.6 (50)	31.1 (275)	16.9 (150)
2 (33.6)	4.5 (40)	5.6 (50)	31.1 (275)	16.9 (150)
1 (42.4)	-	5.6 (50)	31.1 (275)	16.9 (150)
1/0-2/0 (53.5-67.4)	-	5.6 (50)	43.5 (385)	20.3 (180)
3/0-4/0 (85.0-107.2)	-	5.6 (50)	56.5 (500)	28.2 (250)
250-350 (127-177)	-	5.6 (50)	73.4 (650)	36.7 (325)
400 (203)	-	5.6 (50)	93.2 (825)	36.7 (325)
500 (253)	-	5.6 (50)	93.2 (825)	42.4 (375)
600-750 (304-380)	-	5.6 (50)	113.0 (1000)	42.4 (375)
800-1000 (406-508)	-	5.6 (50)	124.3 (1100)	56.5 (500)
1250-2000 (635-1016)	-	-	124.3 (1100)	67.8 (600)

* For values of slot width or length not corresponding to those specified, select the largest torque value associated with the conductor size. Slot width is the nominal design value. Slot length is to be measured at the bottom of the slot.

Note: If a connector has a clamp screw such as a slotted, hexagonal head screw with more than one means of tightening, test the connector using both applicable torque values.

Figure 70 Tightening Torque for Screw-Type Pressure Wire Connectors

7.6 Batteries

Battery location

When determining the battery placement, ensure that the location:

- Is clean, dry, and not exposed to extreme temperatures
- Provides easy access to battery caps for checking the electrolyte level (when using maintenance type batteries)
- Is close to the generator set to keep cables short, ensuring maximum output

Refer to the submittal drawings for the generator set when choosing a battery rack. Figure 71 shows a typical battery system.

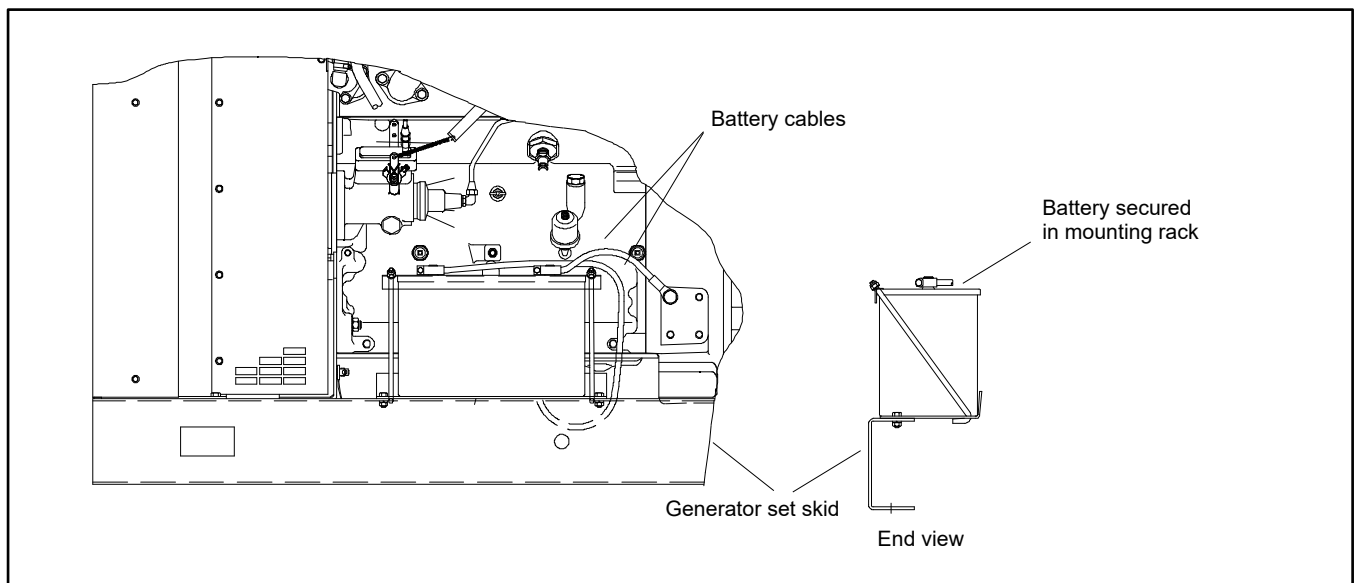

Figure 71 Typical Battery System, Side View

Battery type

Starting batteries are usually the lead-acid type and are sized according to the engine manufacturer's recommendation for a particular ambient temperature and required cranking time. NFPA 110 recommends cranking periods, including a single 45-second cycle for generator sets below 15 kW and three 15-second crank cycles separated by 15-second rests for larger models. Refer to the respective generator set specification sheet for the required battery cold-cranking ampere (CCA) rating.

Nickel-cadmium batteries are sometimes used for standby generator sets because of their long life (20 years). However, initial high cost, larger space requirements, and special charging requirements can offset this benefit. Therefore, conventional lead-acid batteries have proven satisfactory for the majority of generator set applications.

Battery cables

A UL 2200 listed generator set requires battery cables with positive (+) lead boots. Factory-supplied and optional battery cables include positive (+) lead boots. When battery cables are not factory-supplied, source battery cables with positive (+) lead boots for UL 2200 compliance.

Note:

Some units are equipped with an insulating and reflective heat shield sleeve on the battery cables and other wires that are fastened to the starter solenoid. This sleeve is a conductive material and must be secured approximately 25 mm (1 in.) away from the exposed cable terminal.

7.7 Battery Chargers

Most industrial generator sets use an engine-driven, battery-charging alternator to charge the batteries whenever the generator set operates. Engine-driven systems are normally capable of charge rates of 30 amps or more and can quickly restore the charge used in a normal cranking cycle. When the engine is not operating, a very low charge rate from an AC-powered battery charger is usually sufficient to maintain a full charge on the batteries.

Some industrial generator sets have no battery-charging alternator and, therefore, require a separate AC-powered battery charger.

Select an automatic or manual battery charger with a high charge rate of 2 amps and a trickle charge rate up to 300 milliamps. The low maximum charge rate makes the charger ill-suited to restore fully discharged batteries. For full recovery capability independent of the engine-driven charging system, use an automatic float battery charger with a high charge rate of at least 10 amps.

Use separate, self-contained battery chargers or units built into the automatic transfer switch. Run leads from a transfer switch-mounted battery charger in conduit separate from the conduit that holds the generator load cables or remote engine-start circuits.

Note:

Digital controllers with microprocessor circuitry and vacuum fluorescent displays typically draw more than 300 milliamps, making trickle charge battery chargers inappropriate for systems with these controllers. Select only automatic float/ equalize battery chargers with a 3 amp or greater rating for units with digital controllers.

Battery failure is the most common reason for emergency generator set start failure. Two common battery failure causes are a manual charge rate set too low to maintain the battery and a manual charge rate set too high, resulting in loss of battery electrolyte. To avoid battery failure, use an automatic float charger, which varies the charge rate in response to battery condition.

For large engines with two starters, use either one bank of batteries and chargers for both starters or use separate battery systems. The latter system is preferable because it reduces the chance of a single component failure rendering the entire system inoperative.

7.8 Component and Accessory Power Source Requirements

Several components require a power source other than the engine starting batteries. The utility power supply outlet or electrical box should be in close proximity to the generator set. Some factory-supplied enclosures are available with electrical hook-up connections. Most accessories require a dedicated circuit with separate circuit breaker. Comply with applicable national and local codes when providing an electrical power source connection. These items include but are not limited to the following items:

- **Alternator Strip Heater** requires a 110-120 volt or 190-240 volt, 50/60 Hz, 15-amp power source. Check the component and instructions for specific information.
- **Battery Charger** typically requires a 110-120 volt or 190-240 volt, 50/60 Hz power source. Some generator set models require multiple battery chargers. Check the component for specific information as some battery chargers are only 110-120 volt, 50/60 Hz. See the previous section about Battery Chargers for additional information.
- **Battery Heater** requires a 110-120 volt, 50/60 Hz, 15-amp power source. Some kits require multiple outlets for the plate and wrap connections. Check the component and instructions for specific information.
- **Controller Heater** (APM802 Controller only) requires a 208-240 volt, 60 Hz or 230 volt, 50 Hz power source. Check the component and instructions for specific information.
- **Crankcase Ventilation Heater** (Some 125/150 kW Gas Models only) require a 110-120 volt, 50/60 Hz, 37.5 watt power source. Check the component and instructions for specific information.
- **Engine Block Heater** typically requires a 110-120 or 190-240 volt, 50/60 Hz, 15- or 20-amp power source. Some kits require multiple outlet circuits. Check the component and instructions for specific information. See the subsection in this manual about Block Heaters for additional information.

7.9 Optional Accessories

The generator set manufacturer offers optional accessories that require connection to other components in the system. These accessories enable the generator set to meet standards for local and national codes, make operation and service more convenient, or satisfy specific customer installation requirements.

Accessory kits generally include installation instructions. See the wiring diagrams manual for electrical connections not shown in this section. See the installation instructions and drawings supplied with the kit for information on the kit mounting location.

The instructions provided with the accessory kit supersede these instructions, if different. In general, run AC and DC wiring in separate conduit. Use shielded cable for all analog inputs. Observe all applicable national and local electrical codes during accessory installation.

Accessory wiring

To determine the appropriate size for the customer-supplied wiring of the engine battery-powered accessories, use the guidelines in Figure 72. Use 18-20 gauge wire for signal wires up to 305 m (1000 ft.).

Length, m (ft.)		Wire Gauge
30.5	(100)	18-20
152.4	(500)	14
304.8	(1000)	10

Figure 72 Wire Length and Size, Lead N and 42B

Match the wire terminals to the terminal strip conductor screw size. Use a maximum of two wire terminals per terminal strip screw unless otherwise noted on the respective accessory drawing or installation instruction.

Accessory connections

Do not direct-connect accessories to the controller terminal strip. Connect accessories to a dry contact kit. Connect the dry contact kit(s) to the controller (customer) connection kit. Connect all accessories except the emergency stop kit to the connection kit terminal strip(s).

Terminal strips and available connections vary by controller. Refer to the respective controller operation manual and the accessory wiring diagrams in the wiring diagram manual for connection of kits. Field-installed accessories include installation instructions and/or wiring diagrams.

7.9.1 Bus Bar Kits/Bus Lugs

The four bus bars contained in the optional bus bar (load bus) kits simplify the connection process by offering bus connections for load and neutral when the generator set mounted breaker is not selected. Optional bus lugs offer an array of terminal and wire connections. See Figure 73.

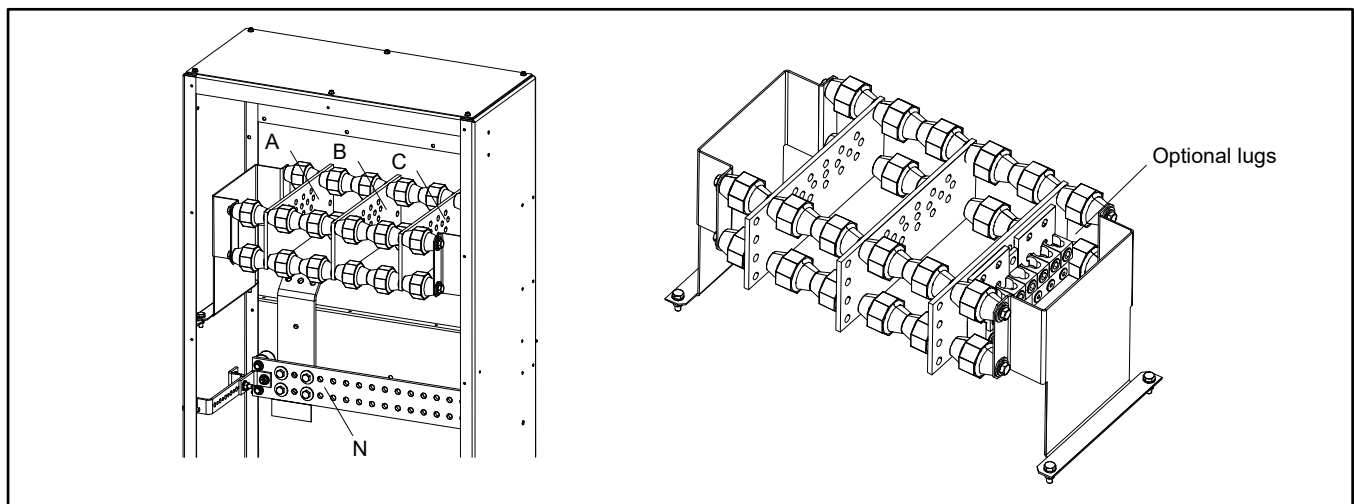

Figure 73 Bus Bar Kits/Bus Lugs

7.9.2 Gas Fuel Valve Kit

This section provides the wiring information for an additional gas fuel valve kit required for UL Approval. See the figure below. Refer to the respective generator set wiring diagrams for additional information and for LP liquid applications.

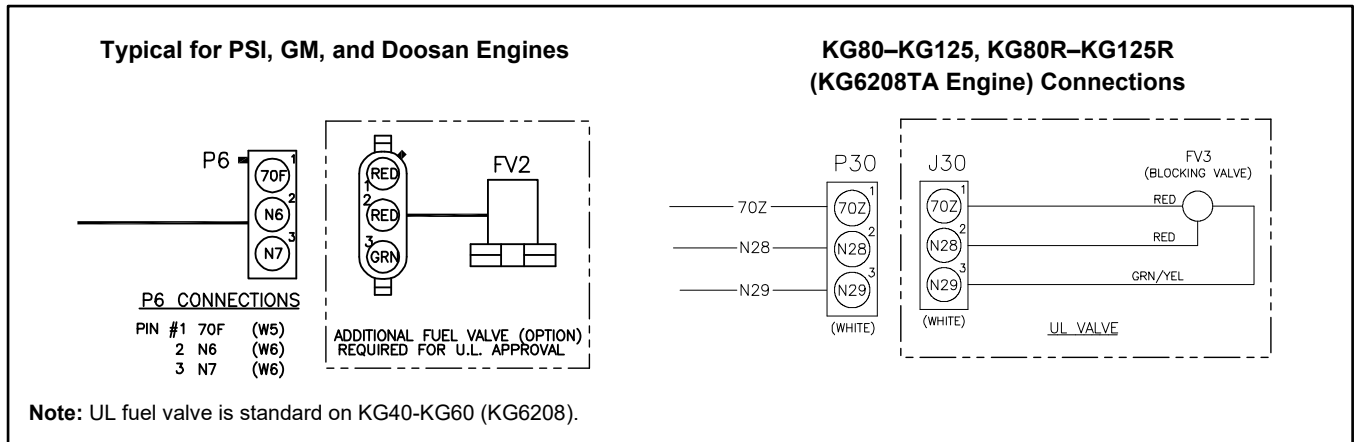

Figure 74 Gas Fuel Valve Kit Connections

7.9.3 Line Circuit Breaker

The line circuit breaker interrupts generator output if an overload or short circuit occurs. Use the line circuit breaker to manually disconnect the generator set from the load during generator set service. See Figure 75.

The circuit breaker must open all ungrounded conductors. Refer to the circuit breaker drawing (ADV-8877) and circuit breaker spec sheet (G6-88) for all trip unit adjustments and settings.

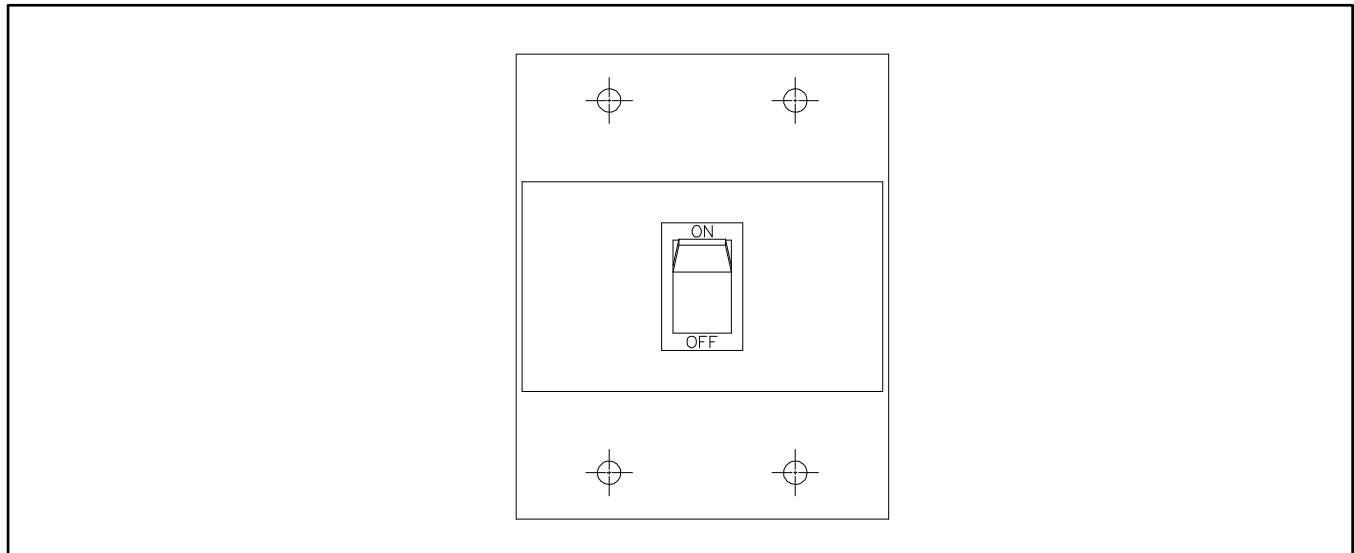

Figure 75 Line Circuit Breaker

7.9.4 Run Relay Kit

The run relay kit energizes only during generator set operation. The three sets of contacts typically control air intake and/or radiator louvers. However, alarms and other signaling devices can also connect to the contacts. See Figure 76.

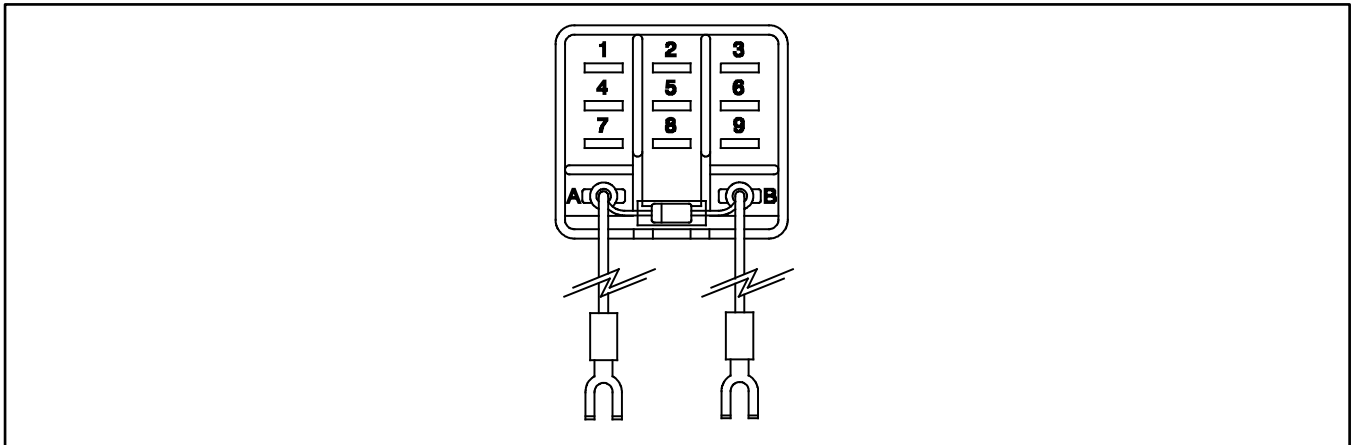

Figure 76 Run Relay Kit

7.9.5 Wiring Connections

Although equipment and connections vary, Figure 77 shows examples of the options and wire connections necessary to make an industrial system operational. Always refer to the wiring diagram for details of wire size, location, and number.

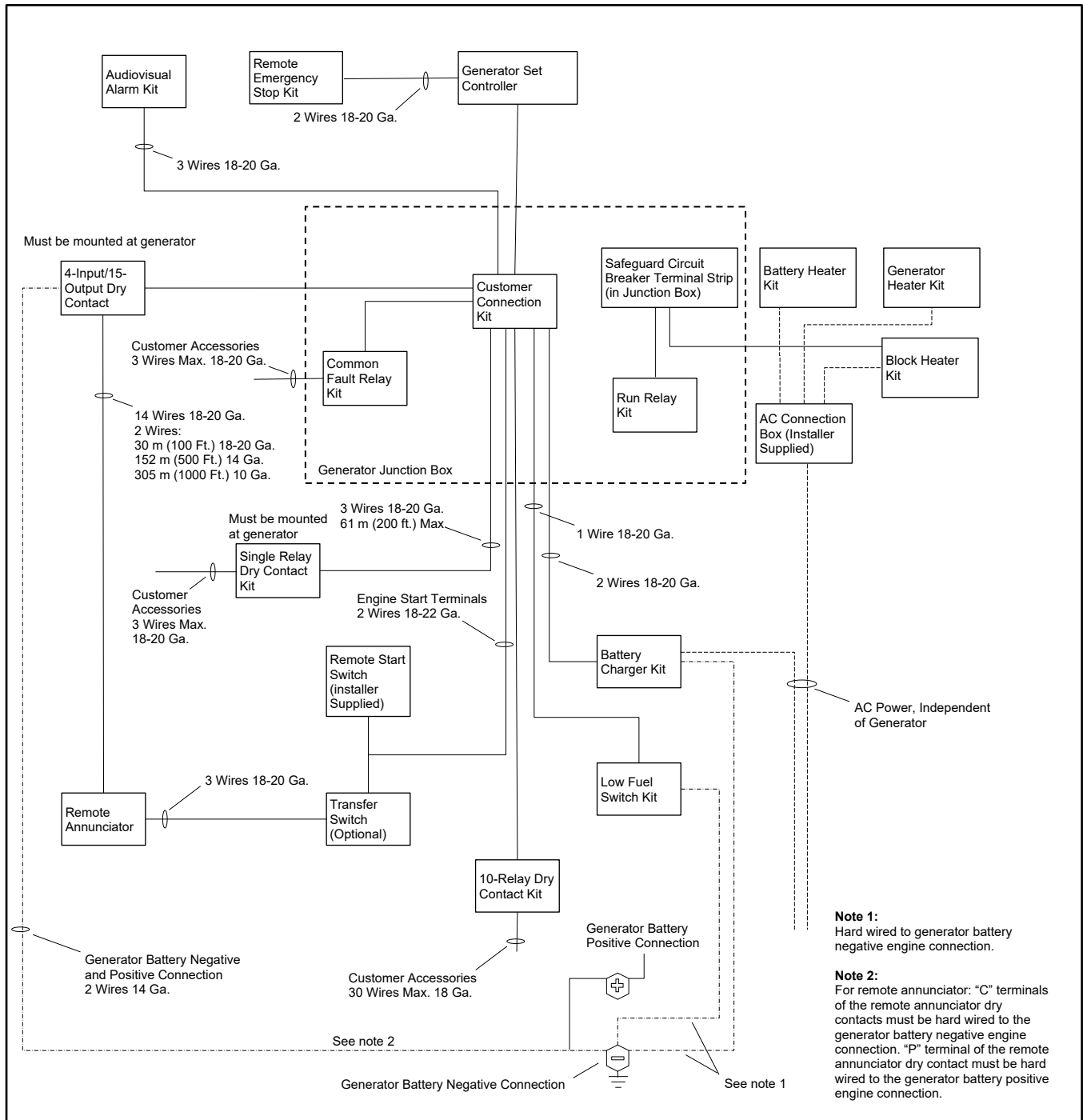

Figure 77 Generator Set Connections, Typical

Notes

Section 8. APM402/Decision-Maker 3000 Controller Accessories

8.1 Accessories and Connections

Note:

In 2018, Rehlko adopted a global controller naming convention. To support this, the name of the Decision-Maker® 3000 controller transitioned to APM402. The APM402 has the same form, fit and function as the Decision-Maker® 3000 and supports the same accessories.

Several accessories help finalize installation, add convenience to operation and service, and establish state and local code compliance.

Accessories vary with each generator set model and controller. Select factory-installed and/or shipped-loose accessories. See the figure below for a list of available kits. Obtain the most current accessory information from your local authorized service distributor/dealer.

This section illustrates several accessories available at print time of this publication. Accessory kits generally include installation instructions. See wiring diagrams manual for electrical connections not shown in this section. See the installation instructions and drawings supplied with kit for information on kit mounting location.

The instructions provided with the accessory kit supersede these instructions where there are differences. In general, run AC and DC wiring in separate conduit. Use shielded cable for all analog inputs. Observe all applicable national, state, and local electrical codes during accessory installation.

See the following subsection, "Accessory Connections," for terminal identification.

Kit Description
Common Fault/Failure (32A) Connections
Fifteen-Relay Dry Contact Kit
Float/Equalize Battery Charger (with alarms)
Gas Fuel Valve Kit
Input/Output Module Board
Low Fuel (Level) Switch
Low Fuel (Pressure) Switch
Prime Power Switch
Remote Emergency Stop
Remote Reset Feature
Remote Serial Annunciator (RSA III)
Shunt-Trip Line Circuit Breaker

Figure 78 Optional Accessories

8.1.1 Battery Charger Kit with Alarm Option

The battery charger with alarm option provides battery charging to the engine starting battery(ies) and connects to the controller for fault detection. Battery chargers for 12- or 24-volt models are available as a generator set accessory. See Figure 79 and Figure 80 for battery connections.

Note:

On charger GM87448, the Battery Charger Fault is communicated through CAN communication and the connection on TB1 is not used.

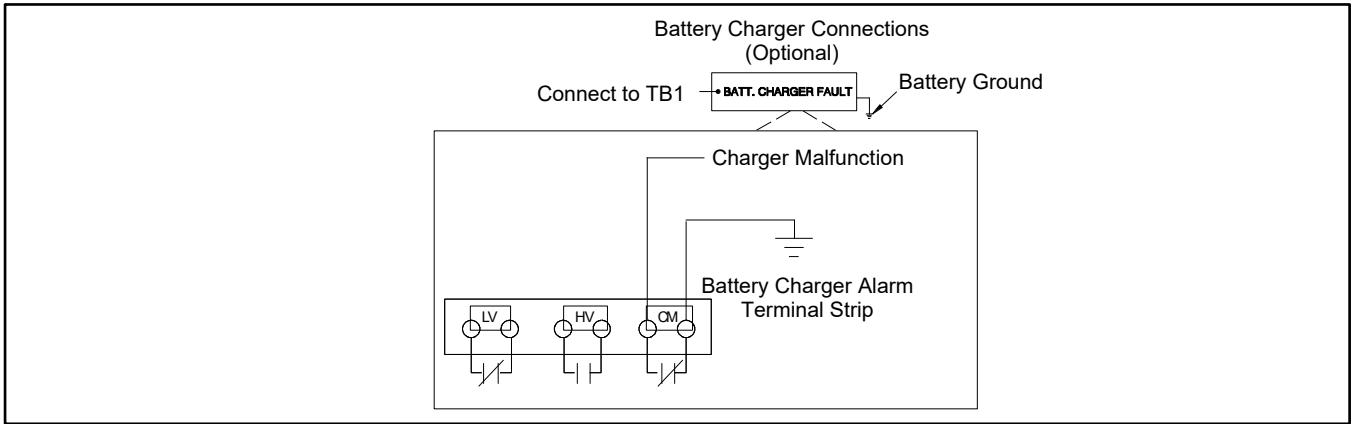

Figure 79 Battery Charger Connections

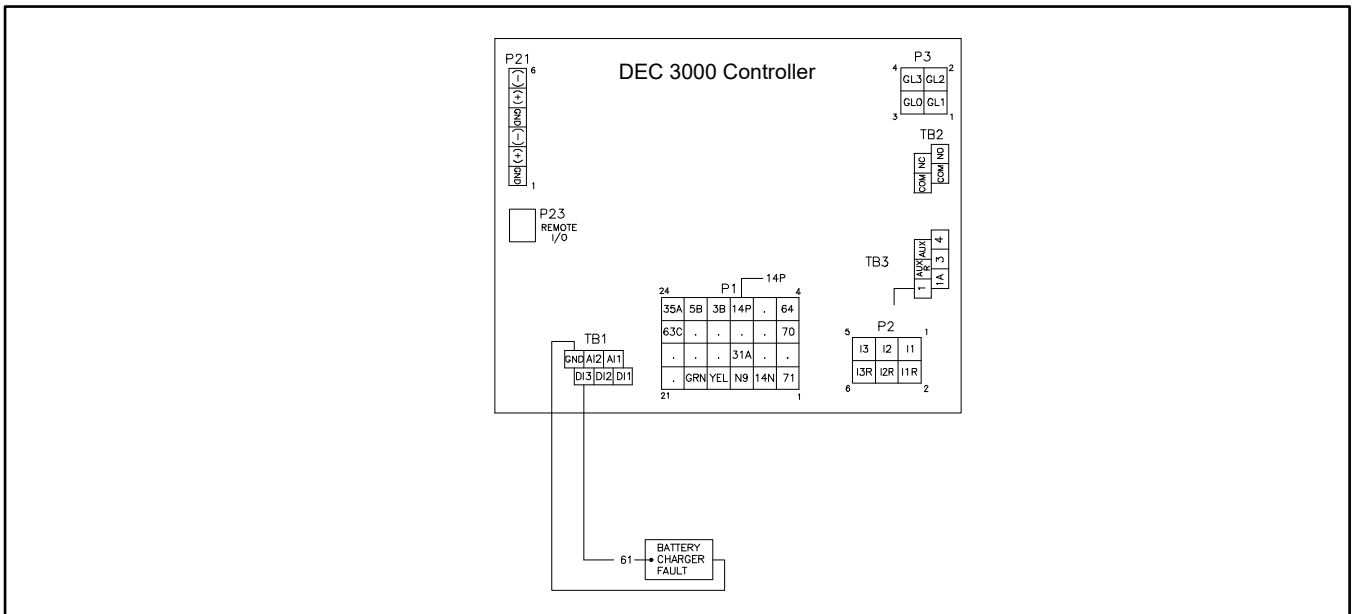

Figure 80 Battery Charger to Controller Connections

8.1.2 Common Fault/Failure (32A) Relay

The common fault relay is standard on the controller circuit board and located at the TB2 terminal strip connections. Contacts are rated at 2 amps at 32 VDC or 0.5 amps at 120 VAC max. See Figure 81 and Figure 82.

The optional common fault relay shown in Figure 82 as DCB2 has contacts rated at 10 amps at 28 VDC or 120 VAC and can be connected to user-supplied accessories.

The optional common fault relay shown in Figure 82 as DCB1 has contacts rated at 10 amps at 28 VDC or 120 VAC and is used to trigger the shunt-trip line circuit breaker kit (mentioned later in this section).

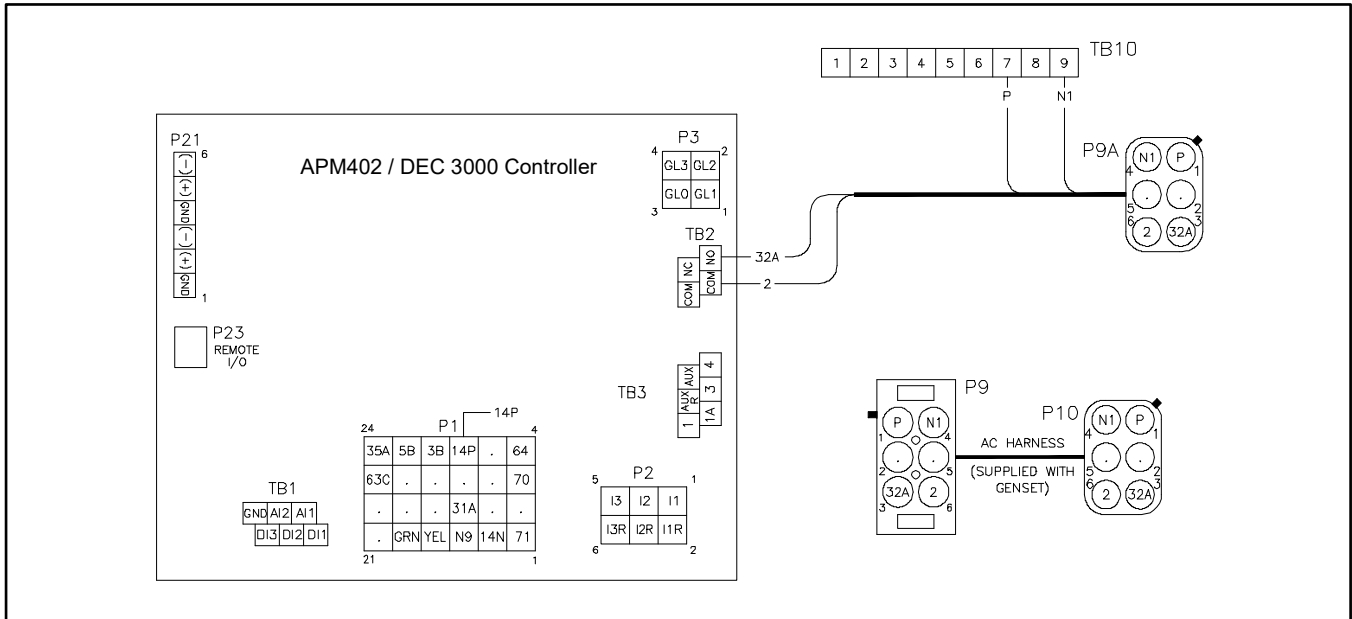

Figure 81 Common Fault Relay Wiring (Standard)

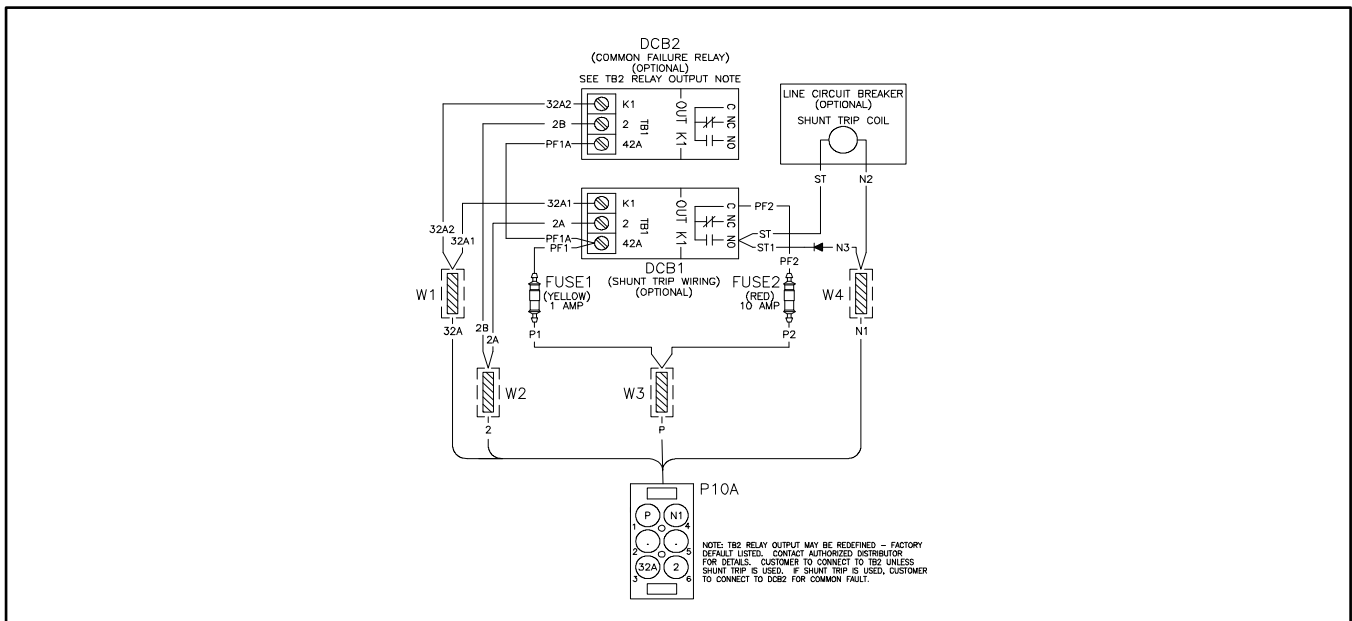

Figure 82 Common Fault Relay Kit and Shunt-Trip Relay Kit Wiring

8.1.3 Four-Input/Fifteen-Output Module

The optional four-input, fifteen-output module is available for selected models. The four-input, fifteen-output module is not available with the two-input, five-output module.

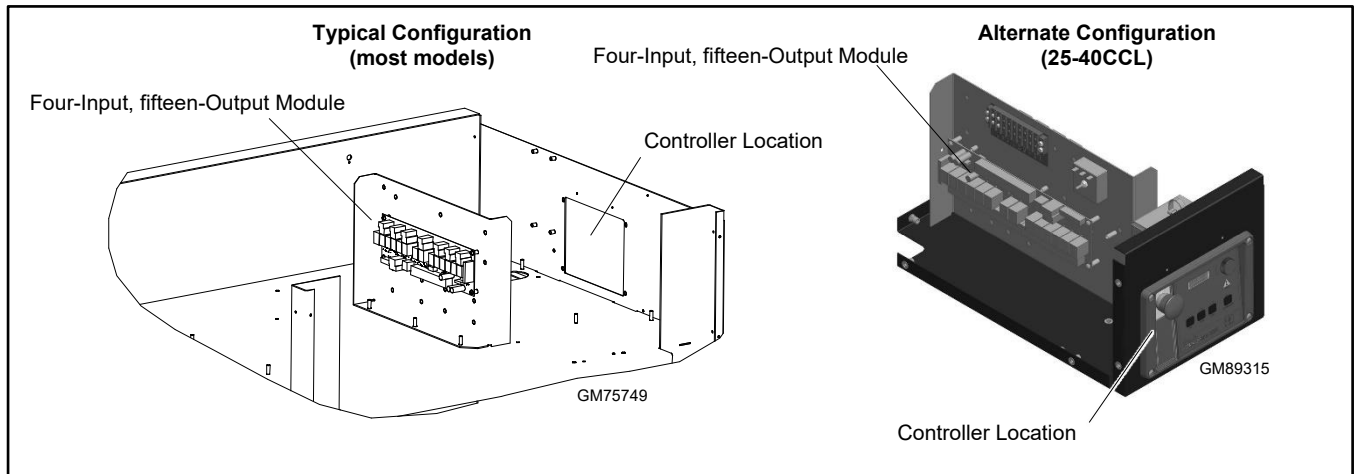

Figure 83 Optional four-Input, fifteen-Output Module

The optional four-input, fifteen-output module (see Figure 83 and Figure 84) provides normally open and normally closed contacts to activate warning devices and other user-provided accessories allowing remote monitoring of the generator set. Connect any controller fault output to the module. Typically, lamps, audible alarms, or other devices signal the fault conditions.

The four-input, fifteen-output module is factory-installed and connected to the controller.

A personal computer with SiteTech™ software is required to assign the inputs and outputs. SiteTech™ is available only to authorized distributors and dealers.

The module has four digital inputs and two analog inputs. There are fourteen programmable relay outputs (K1–K14) and one common fault relay output (K15).

When a generator fault condition occurs, the contact kit relay is energized. The relay energization corresponds to the controller output being activated.

Check the electrical requirements of the user-supplied accessories prior to installation of the input/output module. User-supplied accessories require their own electrical source and must not exceed the relay contact ratings.

Connect to the normally open (NO) or normally closed (NC) terminals as required for each accessory. The relay contacts (K1 to K14) are rated:

- 10 amp @ 120 VAC
- 10 amp @ 28 VDC (max.)
- 0.01 amp @ 28 VDC (min.)

The common fault relay contact (K15) is rated:

- 500 mA @ 125 VAC
- 2 amp @ 30 VDC

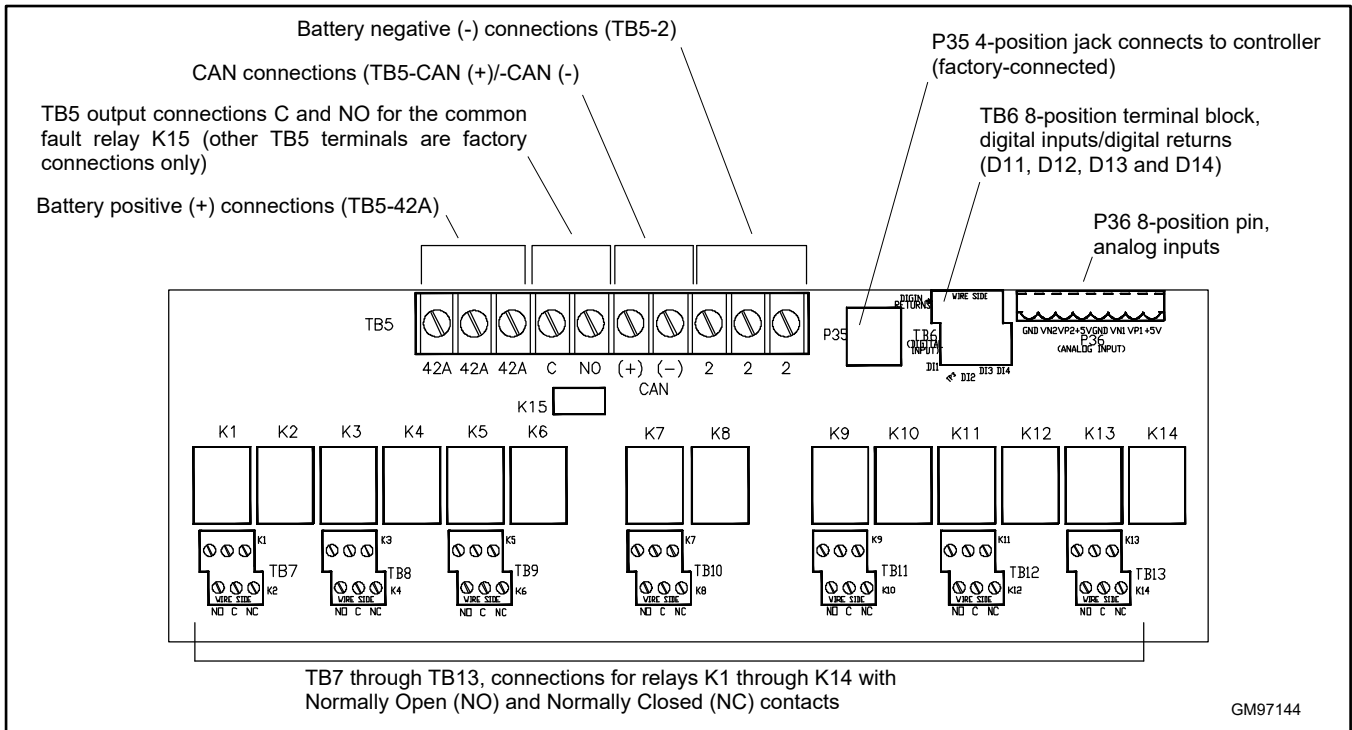

Figure 84 Four-Input, Fifteen-Output Module Customer Connections

Connections



Leads 42A and 2 provide power to the relays. Do not use terminals 42A (+) or 2 (GND) on the controller connection kit terminal strip to supply voltage to user-supplied accessories. User-supplied DC accessories require separate leads connected directly to the battery for the voltage supply. Attach user-supplied 12/24-volt DC accessories to the battery positive (+) connection at the starter solenoid and to the battery negative (-) connection at the engine ground. The 120 VAC accessories require a user-supplied voltage source.

Note:

A maximum of three inputs may be connected to a single relay driver output. Inputs include dry contacts, remote annunciator, common failure alarm, A/V alarm, and shunt trip line circuit breaker.

Note:

Only one four-input, fifteen-output module can be connected to the controller.

 WARNING	Accidental starting. Can cause severe injury or death. Disconnect the battery cables before working on the generator set. Remove the negative (-) lead first when disconnecting the battery. Reconnect the negative (-) lead last when reconnecting the battery.
	

Disabling the generator set. Accidental starting can cause severe injury or death. Before working on the generator set or equipment connected to the set, disable the generator set as follows: (1) Press the generator set off/reset button to shut down the generator set. (2) Disconnect the power to the battery charger, if equipped. (3) Remove the battery cables, negative (-) lead first. Reconnect the negative (-) lead last when reconnecting the battery. Follow these precautions to prevent the starting of the generator set by the remote start/stop switch.

Battery short circuits. Explosion can cause severe injury or death. Short circuits can cause bodily injury and/or equipment damage. Disconnect the battery before generator set installation or maintenance. Remove all jewelry before servicing the equipment. Use tools with insulated handles. Remove the negative (-) lead first when disconnecting the battery. Reconnect the negative (-) lead last when reconnecting the battery. Never connect the negative (-) battery cable to the positive (+) connection terminal of the starter solenoid. Do not test the battery condition by shorting the terminals together.

Electrical Connection Procedure

1. Press the generator set master control OFF/RESET button.
2. Disconnect the power to the battery charger, if equipped.
3. Disconnect the generator set engine starting battery(ies), negative (-) lead first.
4. Remove the top panel of the controller connection box or the front panel of the junction box.
 - a. 25 – 300 kW models: Remove the top panel of the controller connection box.
 - b. 350 – 500 kW models: Remove the front panel from the junction box below the controller.
5. See Figure 85 for connections of analog inputs.
6. Select the normally open (NO) contacts of the relay, Form A dry contact, depending upon the application. Use a two-wire harness for the NO connections.
7. Supply two lengths of stranded wire to make leads long enough to connect the user-supplied device to the dry contact terminals and power supply. Use color-coded wire for easy identification. Make leads long enough to allow for walls, ductwork, and other obstructions. Use separate conduit for the dry contact wiring.
8. **12/24-Volt DC Devices.**

Attach the user-supplied 12/24-volt DC accessories to the starting battery positive (+) connection at the starter solenoid and to the battery negative (-) connection at the engine ground. Otherwise, use a separate 12/24-volt DC supply. Do not use terminals 42A and 2 on the controller connection kit terminal strip to supply the voltage to the relay contacts. Supply separate leads connected directly to the battery for the supply voltage. The circuit must include fuse or circuit breaker protection.

9. **120-Volt AC Devices.**

Connect the user-supplied accessories to a separate 120-volt AC power supply. The circuit must include fuse or circuit breaker protection.

10. Connect the user-supplied device per the Instructions and/or schematic supplied with the device to a power source and to the dry contact terminals. Cut the user-supplied leads to length, strip lead ends, crimp on spade terminals (not supplied), and connect the leads to the relay contact screw terminals. Route the wiring for the relay dry contacts away from the generator set output leads.
11. Repeat Step 6 for the remaining dry contact relays.
12. Replace the cover on the controller connection box.
13. Check that the generator set is in the OFF mode.
14. Reconnect the generator set engine starting battery, negative (-) lead last.
15. Reconnect power to the battery charger, if equipped.

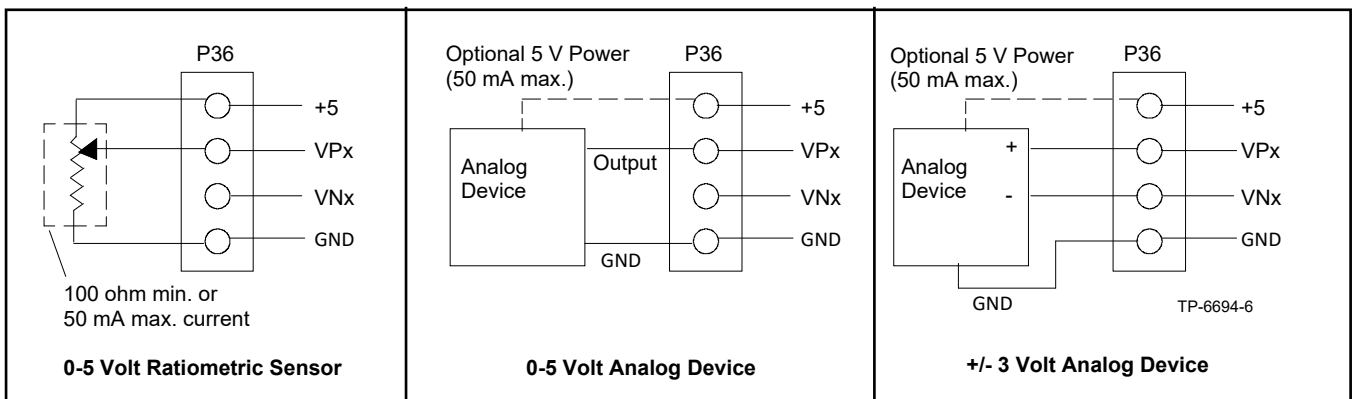

Figure 85 Dry Contact Kit Analog Input Connections P36

Program the inputs and outputs using SiteTech™

Use a computer with SiteTech™ software to assign functions to digital and analog inputs and outputs. Each input and output corresponds to a controller connection. Verify that the settings are appropriate for the connected sensor, switch, or equipment. Do not change factory-set inputs and outputs without verifying the input and output connections.

Refer to Introduction-List of Related Materials for the SiteTech™ Software Operation Manual part no.

SiteTech™ input and output parameters C1 through C14 are designated for use on the four input/fifteen output module. See Figure 86.

Test Dry Contact Relays

Verify the dry contact relay function by using the following procedure when troubleshooting.

1. Remove the user-supplied device wiring from the relay dry contact terminals.
2. Test the relay operation by connecting an ohmmeter across the NO and C terminals on the relay terminal strip.
3. Use a jumper wire to ground the selected fault terminal on the controller connection terminal strip. The relay contacts should close and the ohmmeter should display a low resistance reading (continuity).
4. Install the user-supplied device wiring on the relay dry contact output terminals

SiteTech I/O Name	Optional Dry Contact Board Connection
Analog Input C1	P36 Analog Input VN1/VP1
Analog Input C2	P36 Analog Input VN2/VP2
Digital Input C1	TB6 D11
Digital Input C2	TB6 D12
Digital Input C3	TB6 D13
Digital Input C4	TB6 D14
Digital Output C1	TB7 K1
Digital Output C2	TB7 K2
Digital Output C3	TB8 K3
Digital Output C4	TB8 K4
Digital Output C5	TB9 K5
Digital Output C6	TB9 K6
Digital Output C7	TB10 K7
Digital Output C8	TB10 K8
Digital Output C9	TB11 K9
Digital Output C10	TB11 K10
Digital Output C11	TB12 K11
Digital Output C12	TB12 K12
Digital Output C13	TB13 K13
Digital Output C14	TB13 K14

Figure 86 Optional Inputs and Outputs with 4 Input/15 Output Module

8.1.4 Gas Fuel Valve Kit

This section provides the wiring information for an additional gas fuel valve kit required for UL Approval. See the figure below. Refer to the respective generator set wiring diagrams for additional information and for LP liquid applications.

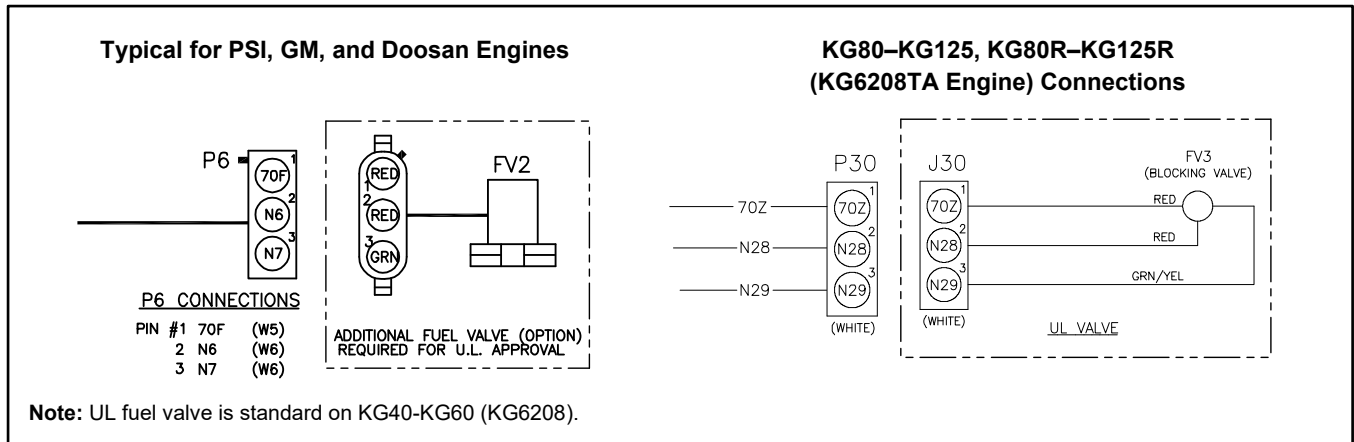

Figure 87 Gas Fuel Valve Kit Connections

8.1.5 Two-Input/Five-Output Module

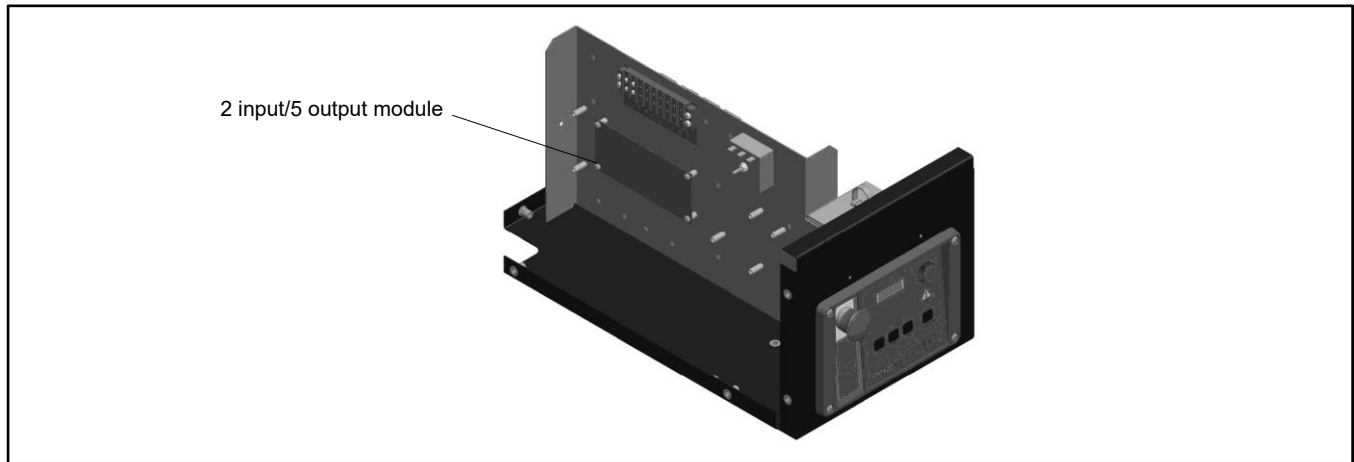

Figure 88 Two-Input/Five-Output Module Location

The two-input/five-output module provides a generator set mounted panel with two analog or digital inputs and five digital outputs. See Figure 90 for circuit board components and electrical connections to the controller.

- See Figure 91 for connections of analog inputs.
- See the following subsection, Accessory Connections, for terminal identification.

Use a computer with SiteTech™ software to assign functions to digital outputs. Each input and output corresponds to a controller connection. Verify that the settings are appropriate for the connected sensor, switch, or equipment.

- Refer to Introduction—List of Related Materials for the SiteTech™ Software Operation Manual part no.

SiteTech™ analog inputs B1 and B2 and digital outputs B1 through B5 are designated for use on the optional two-input/five-output module. See Figure 89.

SiteTech I/O Name	Optional I/O Module Connection
Analog Input B1 Analog Input B2	P28 Analog Input VN1/VP1 P28 Analog Input VN2/VP2
Digital Output B1 Digital Output B2 Digital Output B3 Digital Output B4 Digital Output B5	P29 (K1) P30 (K2) P31 (K3) P32 (K4) P32 (K5)

Figure 89 Input/Output Assignments

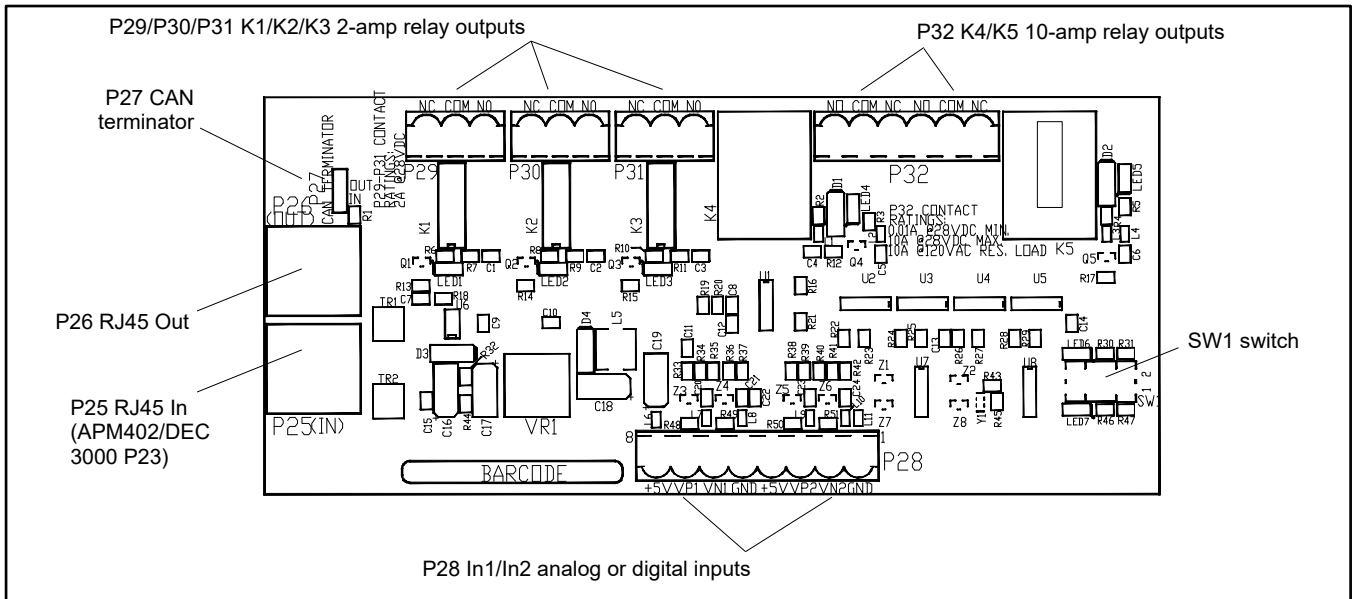

Figure 90 Two-Input/Five-Output Module Board

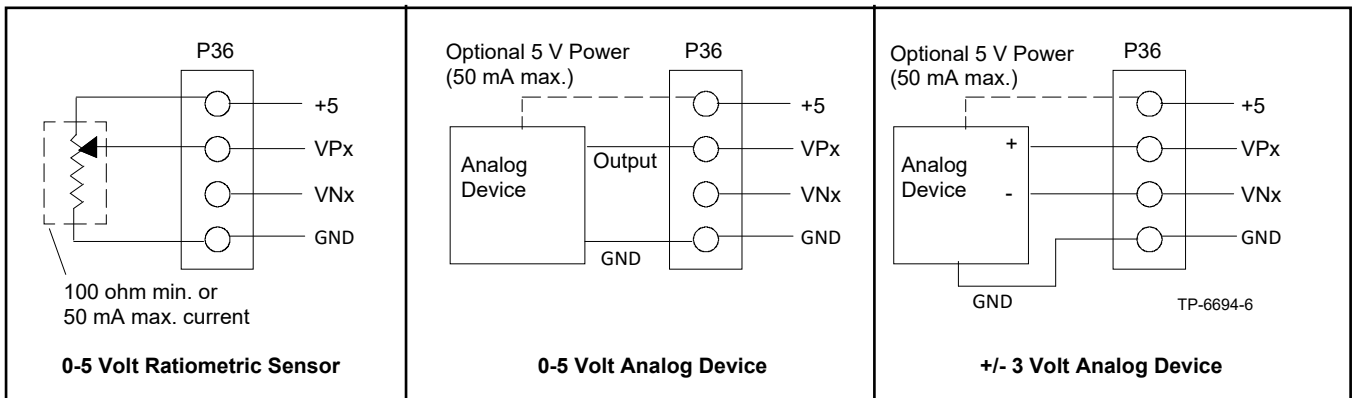

Figure 91 Analog Input Connections P28

8.1.6 Low Fuel (Level/Pressure) Switch

Some gaseous-fueled models offer a low fuel pressure switch. The low fuel pressure switch connects to the same controller terminal as the low fuel level switch on diesel-fueled models. See Figure 92, Figure 93, and Figure 94.

Note:

The main tank or the transfer/day tank includes the low fuel level switch. The fuel tank supplier typically provides the low fuel level switch.

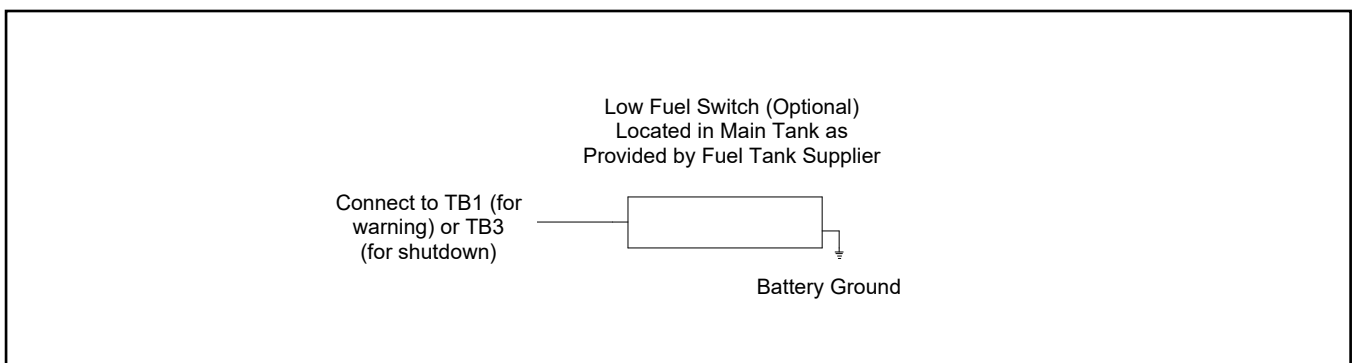

Figure 92 Low Fuel Switch (Level or Pressure)

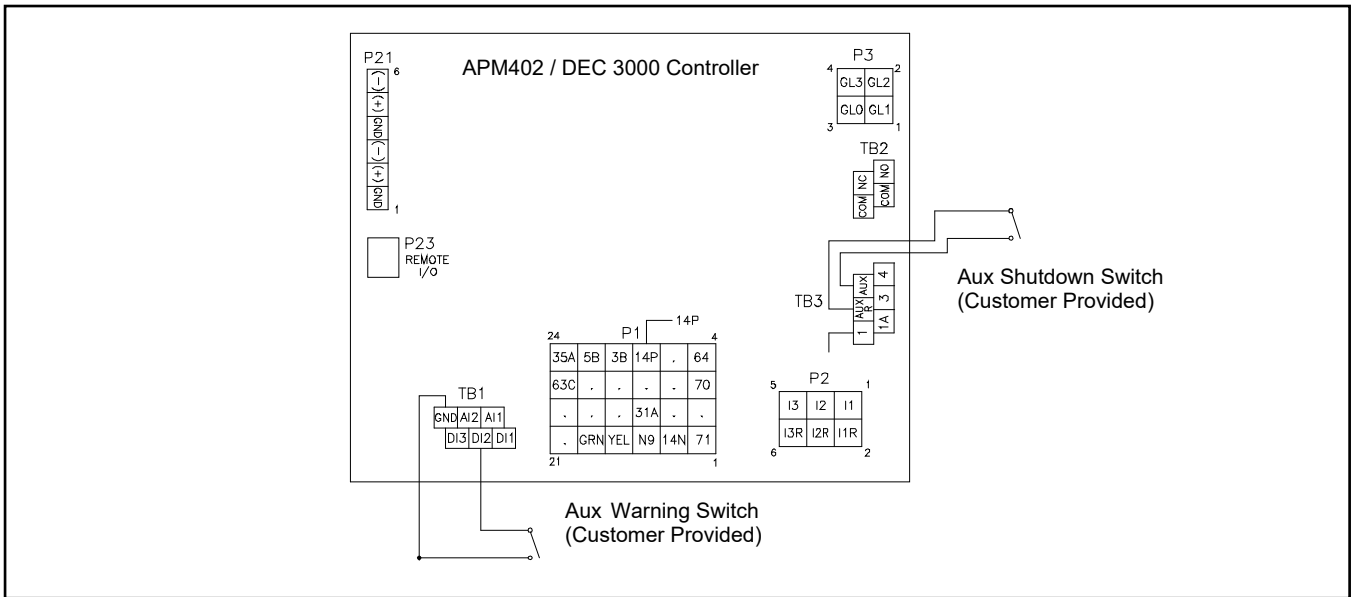

Figure 93 Low Fuel Switch Connection to Controller Connection

Switch Rating	12 volts DC minimum, 0.5 amp minimum
Wiring Recommendation	
Gauge	mm (ft.)
18-20	30.5 (100)
14	153 (500)
10	305 (1000)

Figure 94 Switch Rating & Wiring Recommendation

8.1.7 Prime Power Switch Kit

The prime power switch kit prevents battery drain during generator set no-operation periods and when the generator set battery cannot be maintained by an AC battery charger. See Figure 95 for an illustration of the kit and Figure 96 for the electrical connections.

Stop the generator set using the stopping procedures in respective operation manual before placing the generator set in the prime power mode. Move the prime power switch located on the junction box to the DOWN position. The controller including the digital display, LEDs, and alarm horn does not function when the generator set is in the prime power mode.

Move the prime power switch located on the junction box to the UP position. The generator set is now ready for starting.

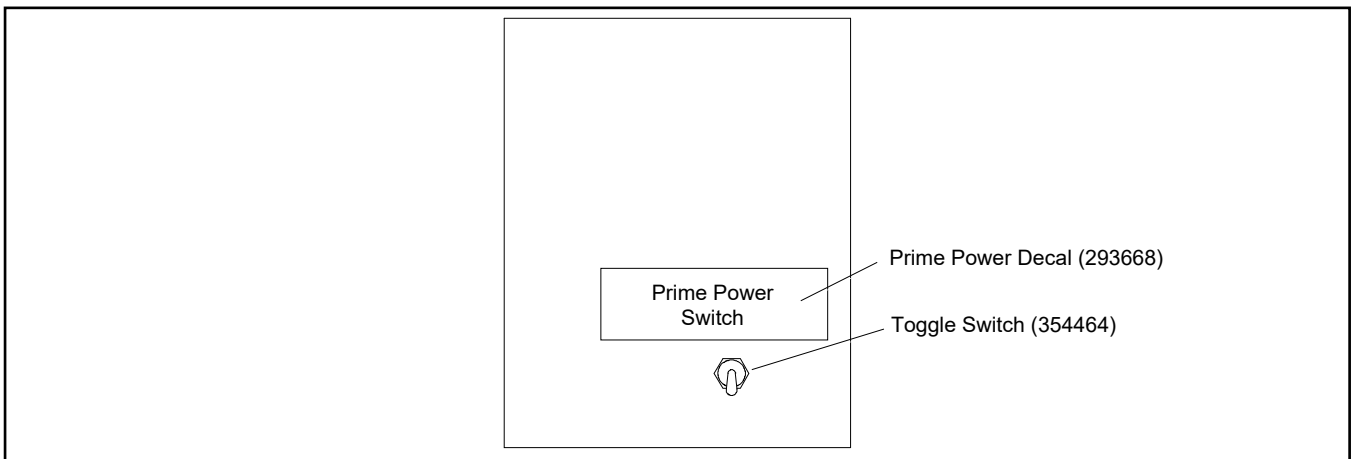

Figure 95 Prime Power Switch

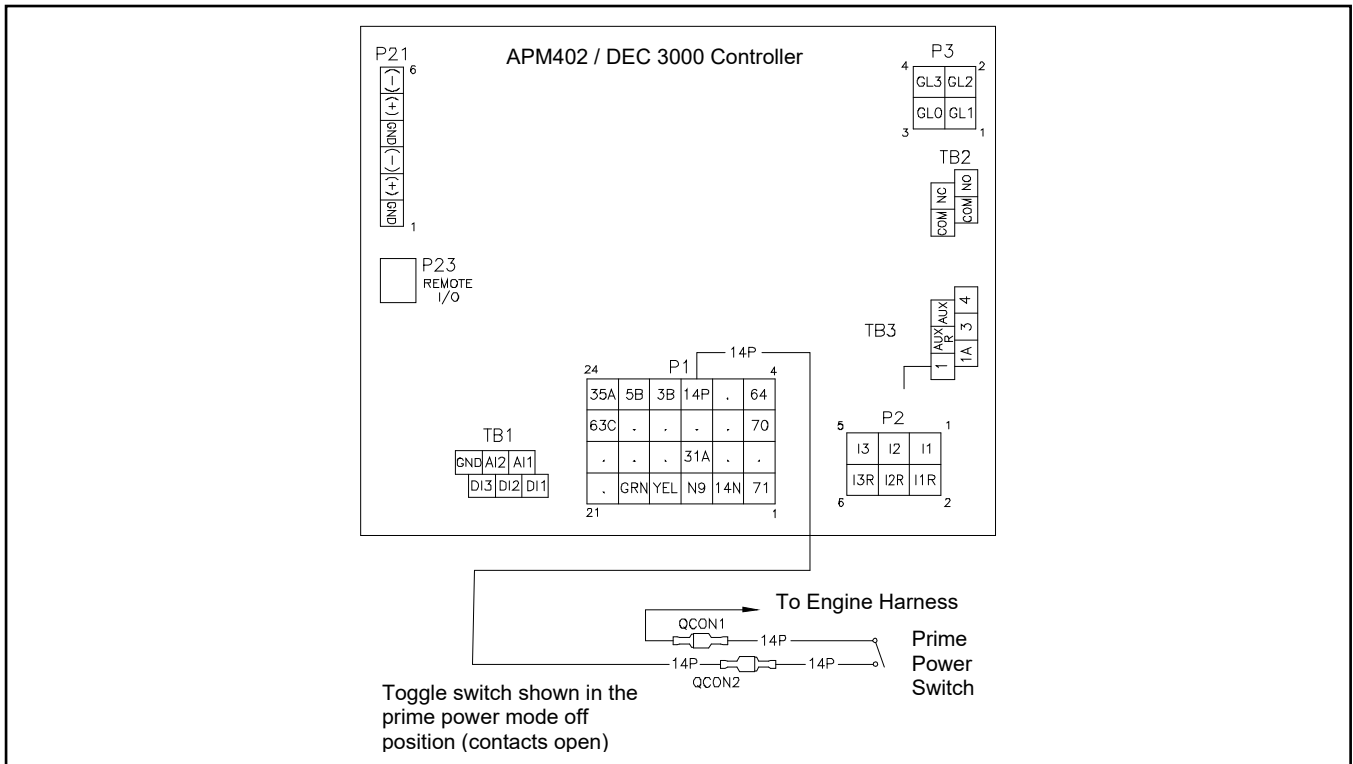

Figure 96 Prime Power Switch Connections

8.1.8 Remote Emergency Stop Kit

The emergency stop kit allows immediate shutdown of the generator set from a remote location. See the following figures for connection details. Install the emergency stop switch in a location that is easily accessible by operating personnel. Connect as many emergency stop switches as required; however, connect multiple switches in series so the system functions correctly.

Two emergency stop kits are available. See the image below.

- For the emergency stop switch, use the single glass piece located inside the switch for replacement and order additional glass pieces as service parts. See the respective operation manual for the Emergency Stop Switch Reset Procedure. See the following subsection, "Accessory Connections," for terminal identifications.
- The lockable emergency stop kit allows the installation of a lockout/tagout device to lock the switch in the STOP position. Insert a locking device through the openings in the shroud to prevent resetting the switch.

Refer to the instructions provided with the kit for installation instructions.

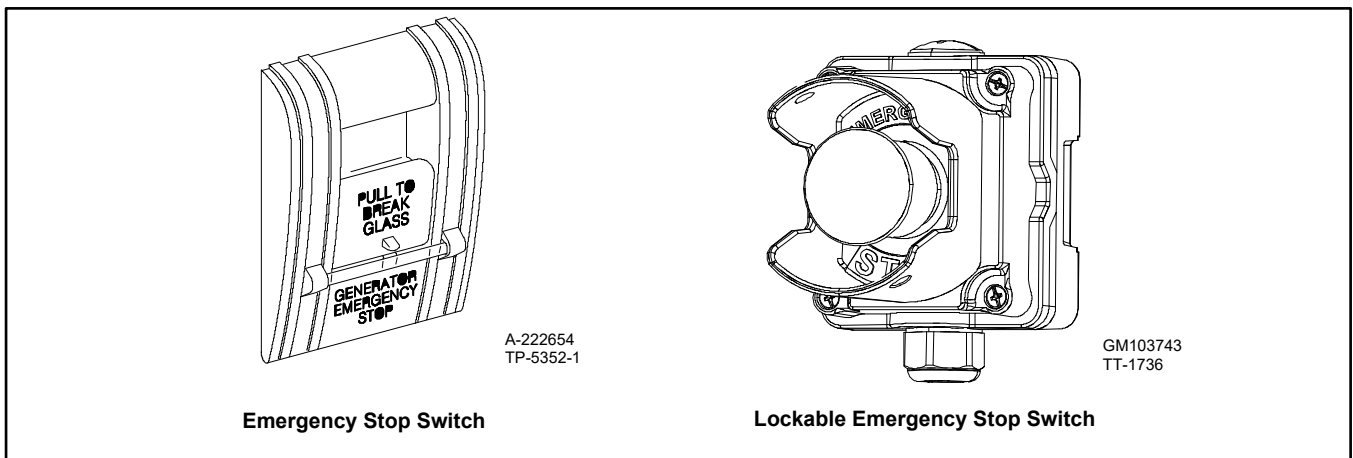

Figure 97 Emergency Stop Kits

See Figure 98 for typical connections. Refer to the generator set wiring diagram for your model. See the following subsection, Accessory Connections, for terminal identifications.

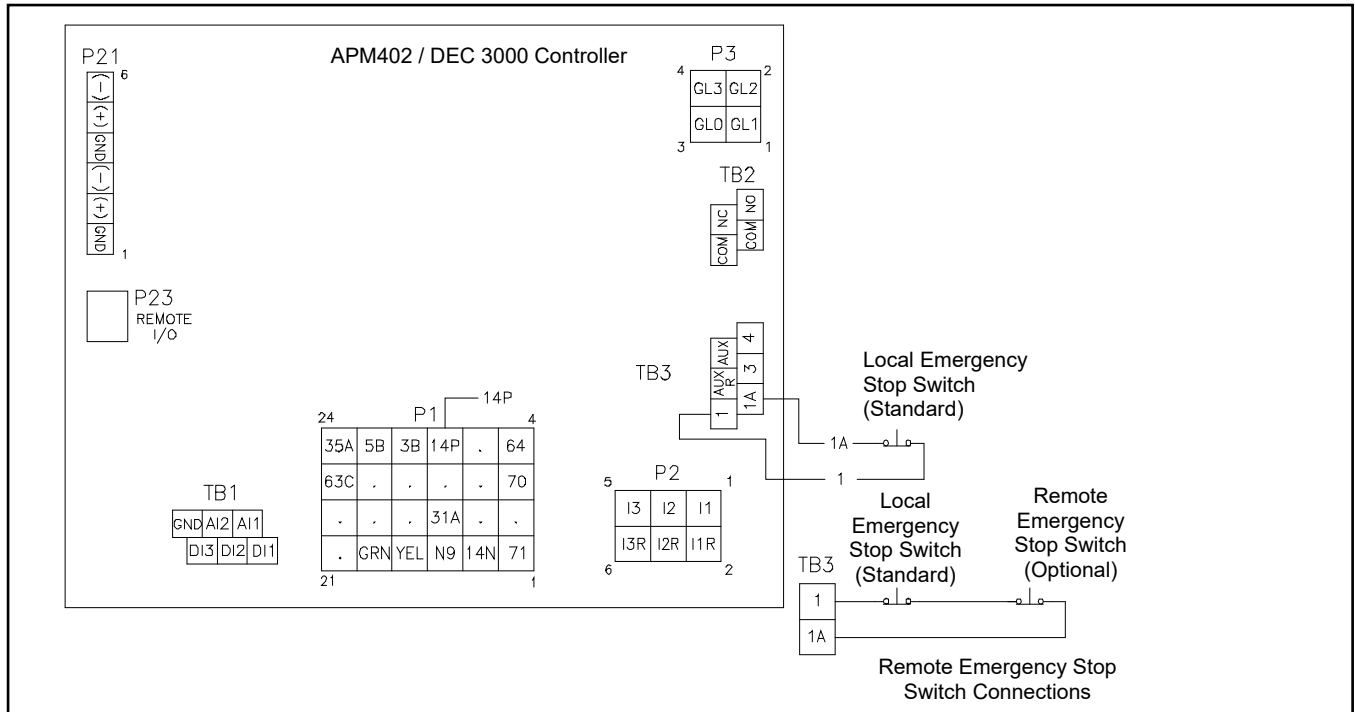

Figure 98 Remote Emergency Stop Kit Connections

8.1.9 Remote Reset Feature

The remote reset switch provides generator set controller resetting after a fault shutdown at a remote location. See Figure 99 and Figure 100 for user-supplied switch connection.

Press and hold the switch for 2-3 seconds and release to reset the generator set controller.

See the following subsection, "Accessory Connections," for terminal identifications.

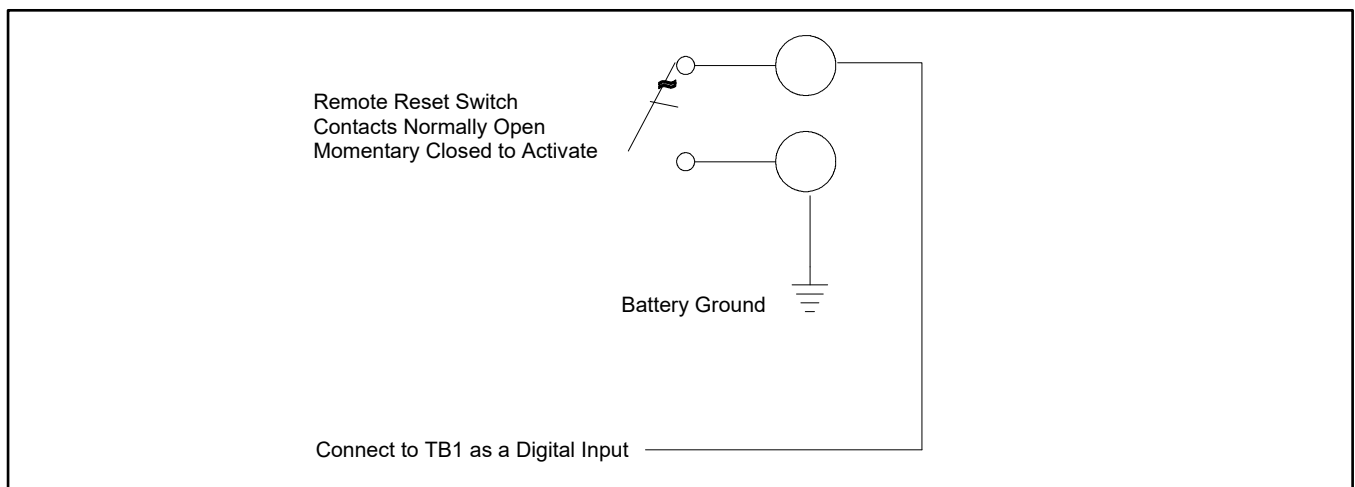

Figure 99 Remote Reset Switch Connections

Switch Rating	12 volts DC minimum, 1 amp minimum
Wiring Recommendation	
Gauge	m (ft.)
18-20	30.5 (100)
14	153 (500)
10	305 (1000)

Figure 100 Switch Rating & Wiring Recommendations

8.1.10 Remote Serial Annunciator (RSA III)

Refer to the RSA III installation instructions, TT-1625.

RSA III is an annunciator panel offered in several kit configurations to support power equipment. The RSA III is a remote serial annunciator that monitors the condition of the generator set and/or ATS from a remote location. The RSA III alerts the operator through visual and audible signals using LED indication and a horn. An alarm silence and lamp test switch are included.

The RSA III meets NFPA 110, Level 1 (2005) applications that require remote controls and alarms to be powered by a storage battery such as the engine starting battery. AC adaptor kit GM62466-KP1 is available when NFPA is not required.

A personal computer (PC) with SiteTech™ software is required to make the RSA III functional. SiteTech™ is available to authorized distributors and dealers.

An RSA III annunciator can be used for a single generator set or with a combination of a generator set and automatic transfer switch(es). In systems using more than a single RSA III, one must be designated as the master device to broadcast to additional RSA III annunciators, designated as slave devices. Up to five RSA III slave devices can be used with an RSA III master device. All RSA III annunciators are factory set as the master device, but can be changed to a slave device using a personal computer (PC) and SiteTech™ software that connects to the RSA III front panel via a universal serial bus (USB) connection.

For long distances and to reduce electrical noise, a lower baud rate, such as 19200, is recommended. See TT-1625 for more details.

Use SiteTech™ software to select that either the generator set controller or the transfer switch activates the EPS Supplying Load LED.

See the subsection, Accessory Connections, for terminal identifications.



Figure 101 Remote Serial Annunciator (RSA III)

Wiring

- For communication between the controller and RSA III master, see the figure below, P27 Connector on Master RSA III.
- For communication between RSA III Master and RSA III Slave, see the figure below, P27 Connection on RSA III Slave.
- Refer to the generator set wiring diagram for the RSA connections to the controller.
- If five or more devices are connected, place a terminating resistor on the last RSA III slave in the daisy chain connection.

Note:

When using RS-485 communication cable, connect the “shield” wire at either end but not at both ends.

P27 RS-485 Connections (from Controller to Master)	
P27-1	(-) Black (from controller)
P27-2	(+) White (from controller)
P27-3	Shield (from controller)
P27-4	(-) Black (to slave or terminating resistor)
P27-5	(+) White (to slave or terminating resistor)
P27-6	Shield (to slave or open)
Note: When using RS-485 communication cable, connect the "shield" wire at either end but not at both ends.	

Figure 102 P27 Connector on Master RSA III

Communication between RSA III Master and RSA III Slave. Select and connect the RS-485 wiring from the RSA III master to the RSA III slave(s) in a daisy chain wiring configuration. The figure below, "P27 Connection on RSA III Slave," shows the master/slave RS-485 connections and "RSA III Circuit Board GM86125 Connectors" shows the RSA III with P27 location.

- For communication connections, use #12-24 AWG shielded, twisted-pair communication cable. For indoor, non-plenum installations, Belden #9841 or equivalent cable is recommended.
- For outdoor or plenum installations, including those with buried cables and/or conduit, use outdoor-rated cable, Belden 3105DB or 3106DN or equivalent.

All wiring must comply with applicable national and local codes.

P27 RS-485 Connections (from Master to Slave)	
P27-1	(-) Black (from master or previous slave)
P27-2	(+) White (from master or previous slave)
P27-3	Shield (from master or previous slave)
P27-4	(-) Black (to next slave or terminating resistor)
P27-5	(+) White (to next slave or terminating resistor)
P27-6	Shield (to next slave or open)
Note: When using RS-485 communication cable, connect the "shield" wire at either end but not at both ends.	

Figure 103 P27 Connection on RSA III Slave

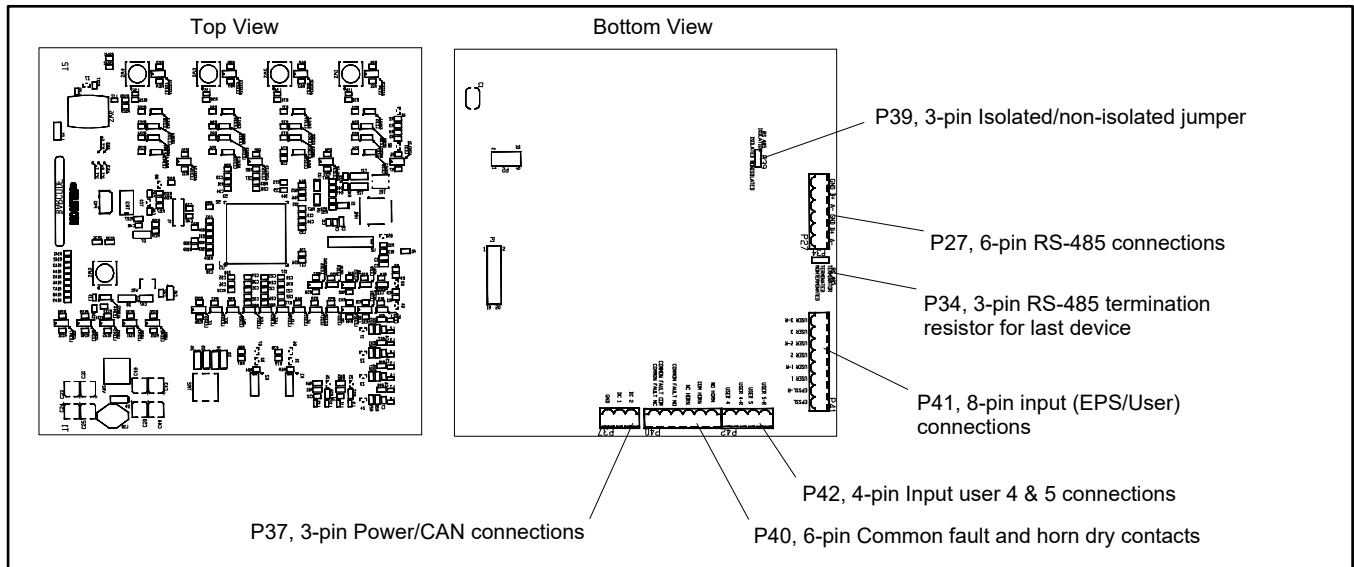

Figure 104 RSA III Circuit Board GM86125 Connectors

8.1.11 Shunt-Trip Line Circuit Breaker

A shunt-trip line circuit breaker provides a 12- or 24-DC volt solenoid within the line circuit breaker case that can energize the trip mechanism. This feature allows the circuit breaker to be tripped by the common fault (32A). Connection requires a shunt-trip wiring kit and a dry contact kit. See Figure 105 and Figure 106.

The optional common fault relay shown in Figure 106 as DCB2 has contacts rated at 10 amps at 28 VDC or 120 VAC and is used to trigger the shunt-trip line circuit breaker kit.

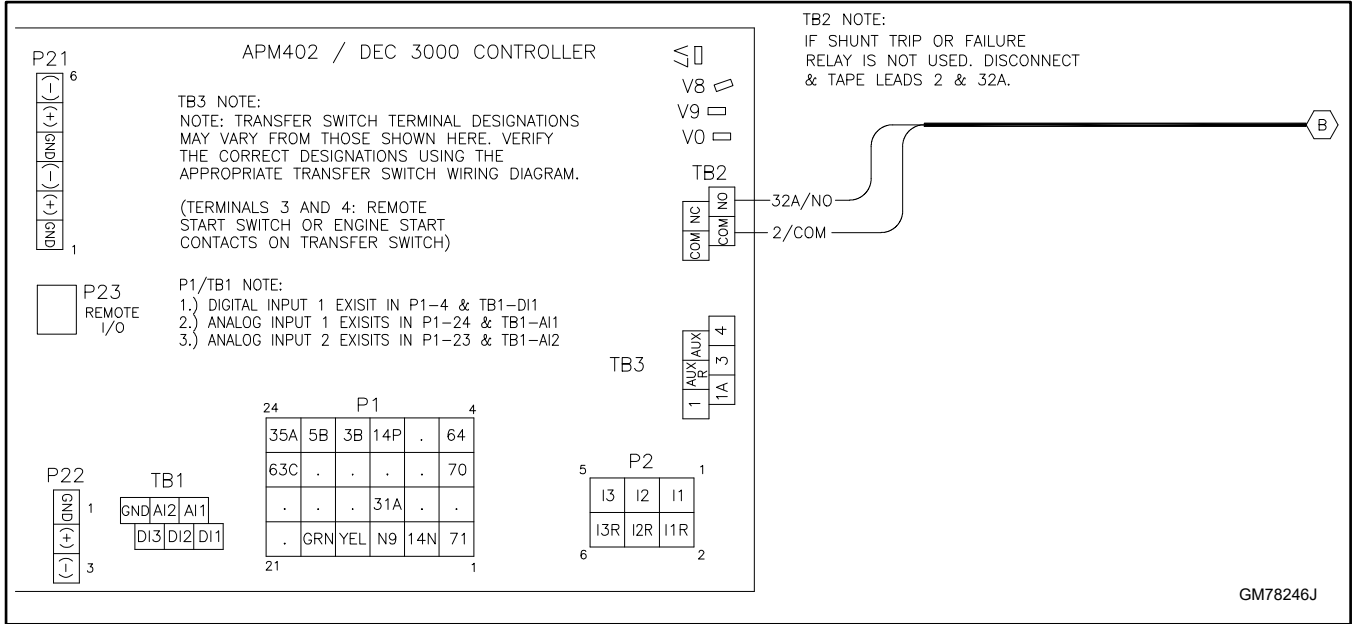

Figure 105 Shunt-Trip Wiring (Standard)

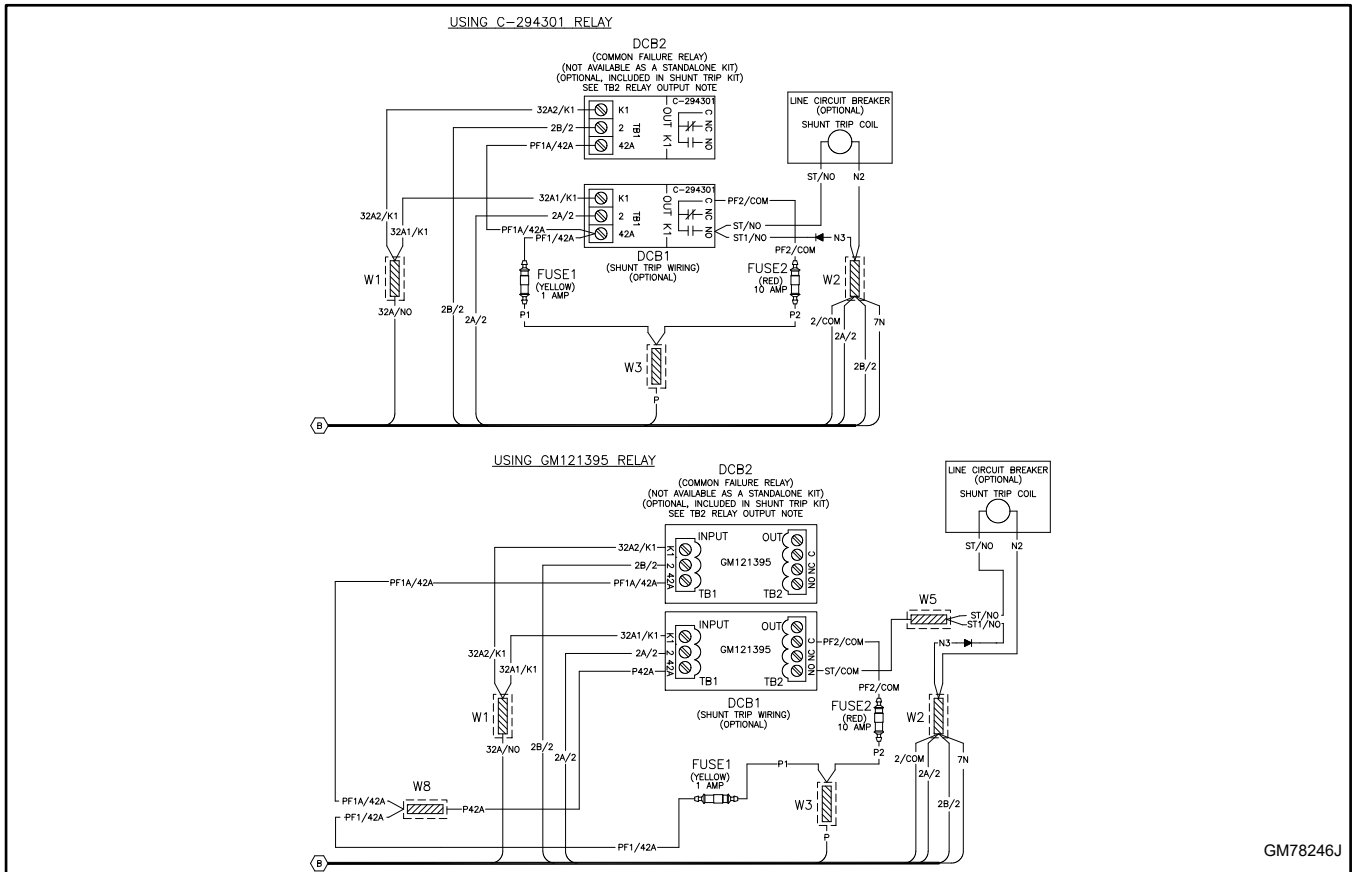

Figure 106 Shunt-Trip Relay Kit and Line Circuit Breaker Wiring (Shown with Common Fault/Failure Relay Kit)

8.2 Accessory Connections

The controller contains a circuit board equipped with terminal strip(s) for use in connecting external optional accessories including alarms, battery chargers, and remote switches. The optional I/O board provides an additional two analog or digital inputs and five digital outputs.

For specific information on accessory connections, refer to the accessory wiring diagrams in the wiring diagram manual and the instruction sheet accompanying the kit. See Figure 107, Figure 108, and Figure 109 for controller circuit board connections.

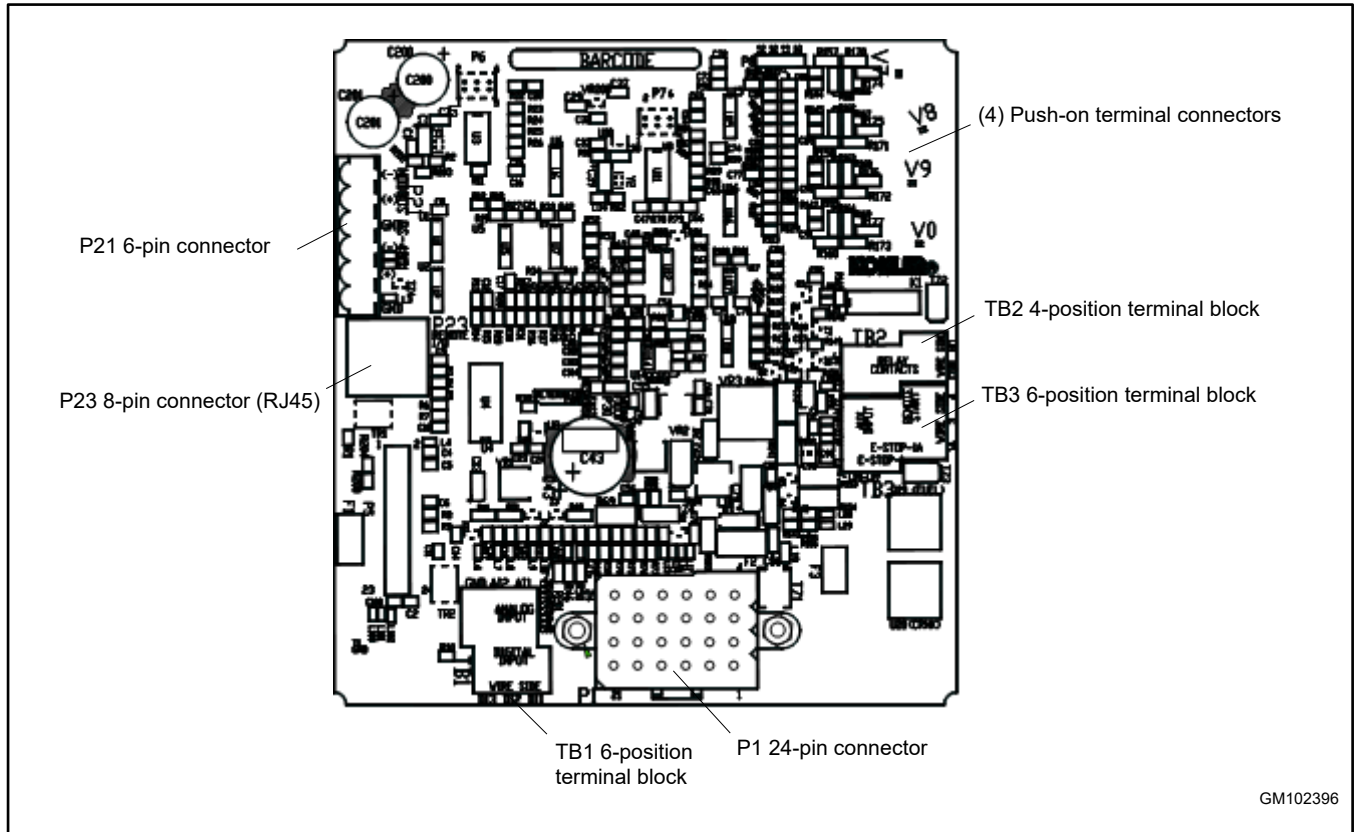

Figure 107 Controller Circuit Board Connections

TB1 Terminal Strip		
Analog and Digital Input Connections		
Terminal	Description	Connection
TB1-DI 1	DCH1	No Function
TB1-DI 2	DCH2	Aux. Warning Switch
TB1-DI 3	DCH3	Battery Charger Fault
TB1-AI 1	ACH1	No Function
TB1-AI 2	ACH2	No Function
TB1-GND	Ground	Common A/D Ground
TB2 Terminal Strip		
KI Relay Outputs		
Terminal	Description	Connection
TB2-COM	Common	User-Defined
TB2-COM	Common	Common Fault (2)
TB2-NO	Normally Open	Common Fault (32A)
TB2-NC	Normally Closed	User-Defined
TB3 Terminal Strip		
Accessory Power Output Connections		
Terminal	Description	Connection
TB3-1	E-Stop	E-Stop Ground
TB3-1A	E-Stop	E-Stop
TB3-3	Remote Start	Remote Start
TB3-4	Remote Start	Remote Start
TB3-AUX	Auxiliary	Aux. Shutdown Sw.
TB3-AUXR	Auxiliary-R	Aux. Shutdown Sw.
P1 24-Pin Connector		
Engine Wiring Harness		
Terminal	Description	Connection
P1-12	14P + 12VDC	Prime Power Switch
P21 6-Pin Connector		
RS-485 (RSA II)		
Terminal	Description	Connection
P21-1	GND	Shield
P21-2	(+)	Red
P21-3	(-)	Black
P21-4	GND	Shield
P21-5	(+)	Red
P21-6	(-)	Black
TB1 Terminal Strip Designations		
Analog and Digital Input Connections		
Terminals on Board	Controller Designation	SiteTech Designation
TB1-DI 1	DIn A1	A1
TB1-DI 2	DIn A2	A2
TB1-DI 3	DIn A3	A3
TB1-AI 1	AIn A1	-
TB1-AI 2	AIn A2	A1
TB1-GND	-	-

Figure 108 Controller Connections

P25 Connector		
RJ45 Remote I/O In		
Connects to APM402/DEC 3000 P23		
P26 Connector		
RJ45 I/O Out		
Open		
P27 Connector		
CAN Terminator		
Place the P27 jumper on the IN pins		
P28 Connector		
Single-Ended (0-5 V) Analog Input Connections		
Terminal	Description	
P28-GND	AGND Analog return	
P28-VN1	NO Connection	
P28-VP1	ACH1 Signal	
P28-+5V	Supply (0.05 amp max.)	
P28-GND	AGND Analog Return	
P28-VN2	NO Connection	
P28-VP2	ACH2 Signal	
P28-+5V	Supply (0.05 amp max.)	
P28 Connector		
Differential (+/-3 V) Analog Input Connections		
Terminal	Description	
P28-GND	AGND Analog Reference	
P28-VN1	ACH1 Negative Differential Signal	
P28-VP1	ACH1 Positive Differential Signal	
P28-+5V	Supply (0.05 amp max.)	
P28-GND	AGND Analog Reference	
P28-VN2	ACH2 Negative Differential Signal	
P28-VP2	ACH2 Positive Differential Signal	
P28-+5V	Supply (0.05 amp max.)	
P29 Connector		
2 Amp. K1 Relay Output (2.1) Connections		
Terminal	Description	
P29-NC	Normally Closed	
P29-COM	Common	
P29-NO	Normally Open	
P30 Connector		
2 Amp. K2 Relay Output (2.2) Connections		
Terminal	Description	
P30-NC	Normally Closed	
P30-COM	Common	
P30-NO	Normally Open	
P31 Connector		
2 Amp. K3 Relay Output (2.3) Connections		
Terminal	Description	
P31-NC	Normally Closed	
P31-COM	Common	
P31-NO	Normally Open	
P32 Connector		
10 Amp. K4 Relay Output (2.4) Connections		
Terminal	Description	
P32-NC	Normally Closed	
P32-COM	Common	
P32-NO	Normally Open	
10 Amp. K5 Relay Output (2.5) Connections		
Terminal	Description	
P32-NC	Normally Closed	
P32-COM	Common	
P32-NO	Normally Open	
P28 Connector Designations		
Terminals on Board	Controller Designation	SiteTech Designation
P28-GND	DIn B1	B1
P28-VN1		
P28-VP1		
P28-+5V		
P28-GND	Din B2	B2
P28-VN2		
P28-VP2		
P28-+5V		

Figure 109 Input/Output Module Board Connections

Section 9. APM603 Controller Accessories and Connections

This section covers typical APM603 accessories when used with most generator sets. For connecting accessories to the APM603 with generator sets KD800-KD3250, see the following section.

9.1 APM603 Controller Optional Connections

The APM603 provides a number of standard on-board inputs and outputs. Connect to these inputs and outputs at terminal strip TB12. See subsection “Controller Connections” for a list of TB12 connections and contact ratings. Also see the generator set wiring diagram.

Run AC and DC wiring in separate conduit. Use shielded cable for all analog inputs. Observe all applicable national, state, and local electrical codes when making connections.

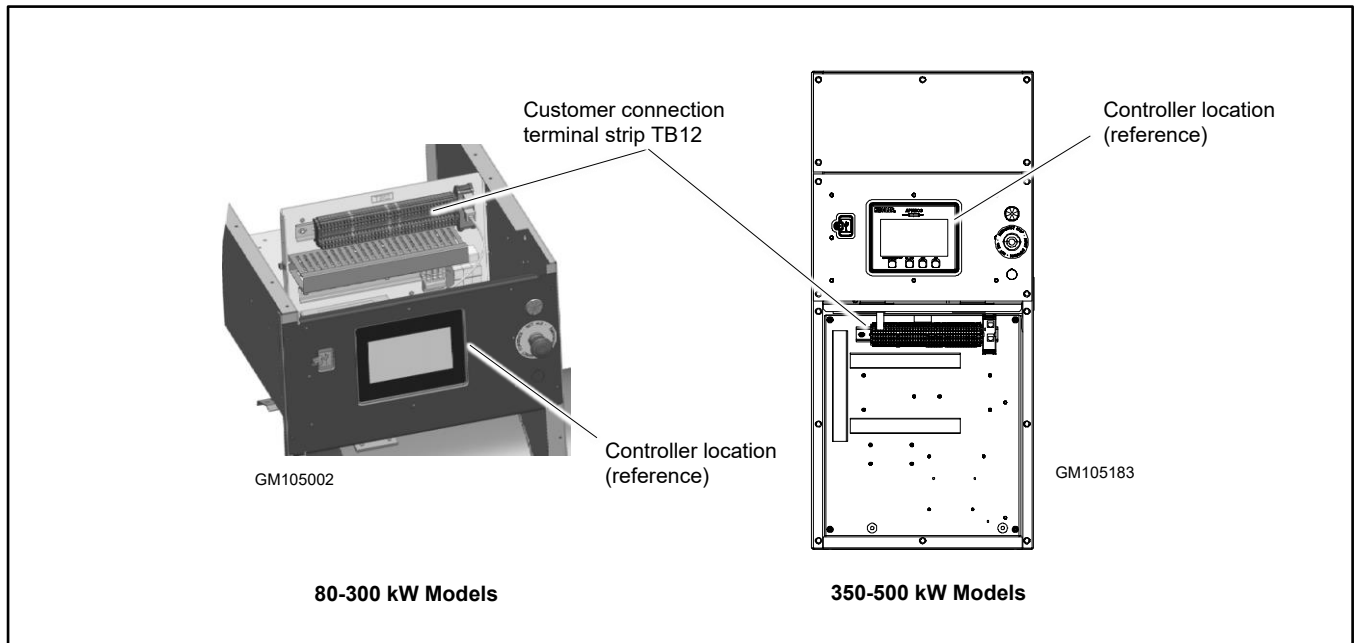

Figure 110 Terminal Strip TB12 Location

9.1.1 Run Relay

The APM603 controller is supplied with a run relay that is energized when the generator set engine is running. The run relay provides normally open (NO) and normally closed (NC) contacts for connection to customer-supplied equipment. Connect customer equipment to the run relay (RR) connections on terminal strip TB12. Section for TB12 connections and contact ratings. Also see the generator set wiring diagram.

9.1.2 Factory-Defined Inputs and Outputs

Factory-defined inputs and outputs are shown in subsection “Controller Connections”. Connect to these inputs and outputs at customer connection terminal block. See Figures for terminal block connections and contact ratings. Also see the generator set wiring diagram.

These factory-defined user inputs and outputs are not adjustable.

9.2 Accessories and Connections

Optional accessories help finalize installation, add convenience to operation and service, and establish state and local code compliance.

Select factory-installed and/or shipped-loose accessories. Factory installed kits are not covered in this Installation manual. Refer to the generator set operation manual or the documentation provided with the accessory for operation instructions.

See Figure 111 for a list of available loose kits. Obtain the most current accessory information from your local authorized service distributor/dealer.

Kit Description
Battery Charger, 6 Amps
Battery Charger, 10 Amps w/Alarms
Common Fault/Failure Relay
Four Input/ Fifteen-Output Module
Lockable Emergency Stop Switch
Low Fuel (Level) Switch
Manual Key Switch (factory installed only)
Remote Emergency Stop Switch
Remote Serial Annunciator (RSA III)
Shunt-Trip Line Circuit Breaker
Switchboards

Figure 111 Optional Accessories

This section illustrates selected loose accessories available at print time of this publication. Accessory kits generally include installation instructions.

- See the wiring diagram manual for electrical connections not shown in this section.
- See the installation instructions and drawings supplied with the kit for information on kit mounting location.

The instructions provided with the accessory kit supersede these instructions where there are differences. In general, run AC and DC wiring in separate conduit. Use shielded cable for all analog inputs. Observe all applicable national, state, and local electrical codes during accessory installation.

See subsection Accessory Connections, for terminal identification.

9.2.1 6-Amp Battery Charger Kit

The 6-Amp battery charger kit is available either factory installed or as a loose kit for installation in the field. For 24-volt systems, two chargers are included in the kit. The recommended location for the battery charger(s) varies for different generator set sizes. Follow the instructions provided with the kit for installation and connection.

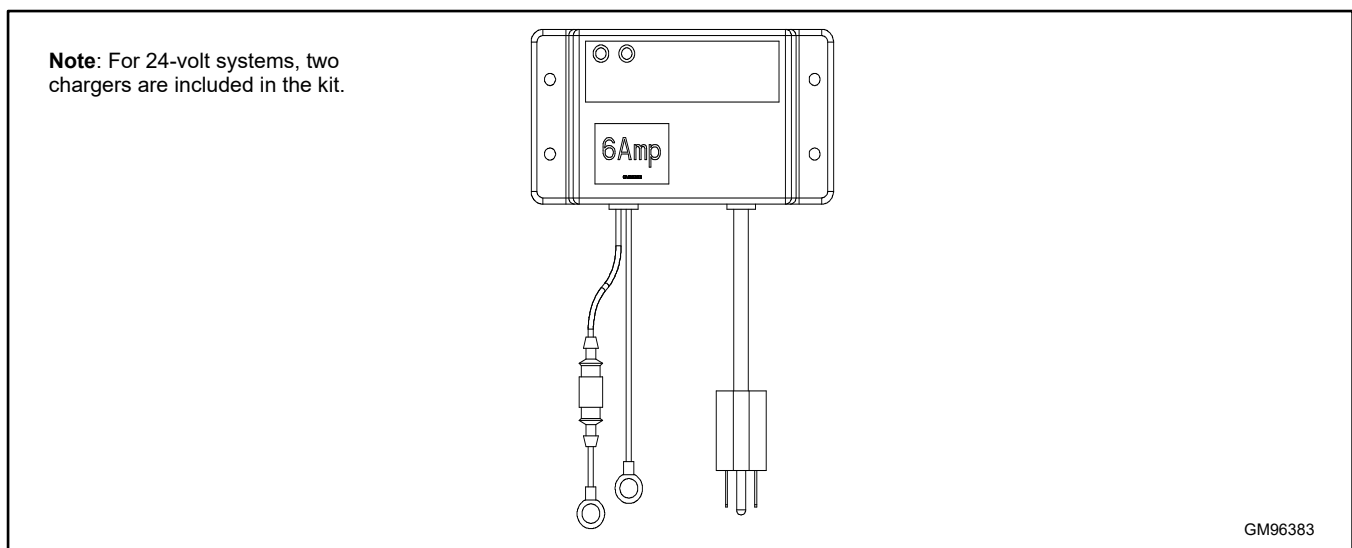

Figure 112 6-Amp Battery Charger (typical)

9.2.2 10-Amp Battery Charger Temperature Compensation Kit

The 10-amp battery charger with alarm option provides battery charging to the engine starting battery(ies) and connects to the controller for fault detection. Battery chargers for 12- or 24-volt models are available as a generator set accessory. The 10-amp battery charger is only available as a factory-installed kit.

A temperature compensation kit is available for the 10-amp battery charger. See Figure 113. The temperature compensation harness connects to the negative (-) battery terminal. Refer to the installation instructions provided with the temperature compensation kit for more information

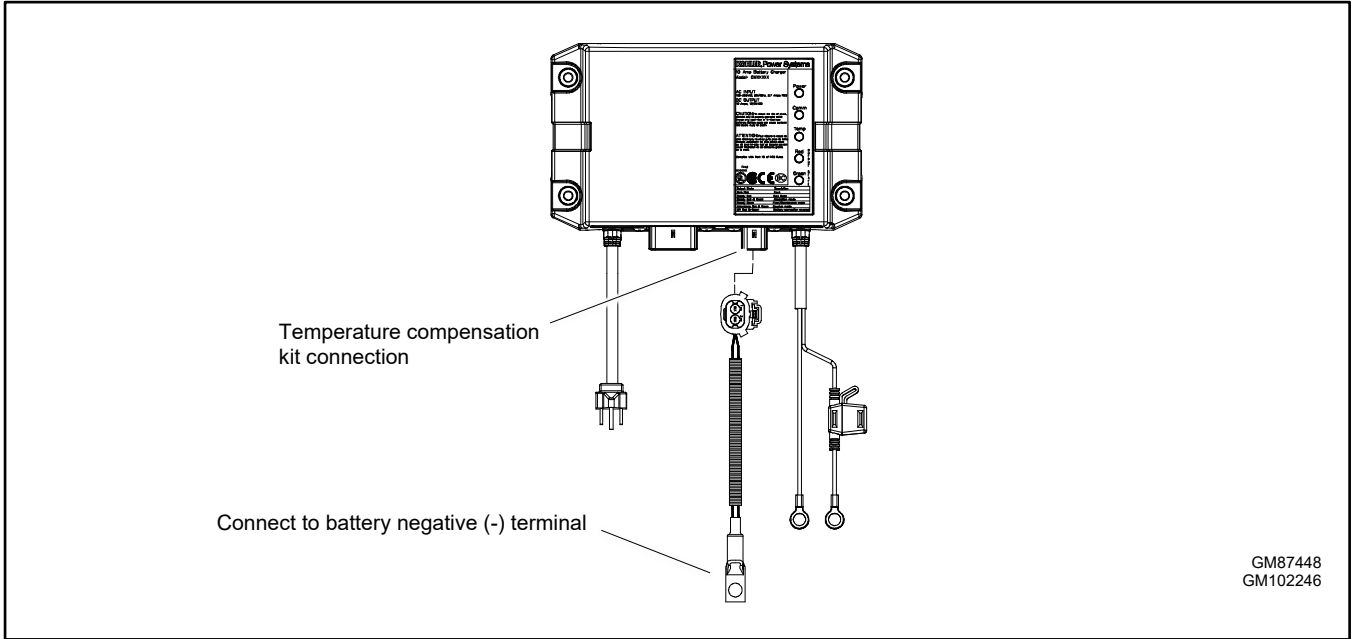

Figure 113 Battery Charger Temperature Compensation Kit

9.2.3 Common Fault/Failure Relay

The optional common fault relay shown in Figure 115 has contacts rated 10 amps at 28 VDC or 120 VAC. Connect user-supplied accessories to the normally open (NO) or normally closed (NC) contacts on TB2 of the relay board. See Figure 116 for customer connection terminals.

Event	Common Warning	Common Fault
Alternator Thermal Protection		•
Battery Charger Fault *	▲	
CAN Option Board Comm Loss	▲	
Critically Low Fuel Level *	▲	
ECM Diagnostic Event	▲	
ECM Mismatch Shutdown		•
Fuel Leak Alarm *	▲	
Gen Over Power Shutdown		•
Gen Over Power Warning	▲	
High Battery Voltage Warning	▲	
High Coolant Temperature Shutdown		•
High Coolant Temperature Shutdown ECM DTC		•
High Coolant Temperature Warning	▲	
High Coolant Temperature Warning ECM DTC	▲	
High Fuel Level Warning *	▲	
High Oil Temperature Shutdown		•
High Oil Temperature Warning	▲	
Local Emergency Stop Shutdown		•
Loss ECM Comms Shutdown		•
Loss Of Signal Low Coolant Level Voltage	▲	
Low Battery Voltage Warning	▲	
Low Coolant Level Shutdown		•
Low Coolant Temperature Warning	▲	
Low Fuel Level Shutdown *		•
Low Fuel Level Warning *	▲	
Low Oil Pressure Shutdown		•
Low Oil Pressure Shutdown ECM DTC		•
Low Oil Pressure Warning	▲	
Low Oil Pressure Warning ECM DTC	▲	
Low RTC Battery Voltage	▲	
Maintenance Reminder1	▲	
Maintenance Reminder2	▲	
Maintenance Reminder3	▲	
Not In Auto Alarm	▲	
Over Crank Shutdown		•
Over Current Shutdown (L1, L2, L3)		•
Over Current Warning (L1, L2, L3)	▲	
Over Frequency Shutdown		•
Over Frequency Warning	▲	
Over Power Shutdown		•
Over Power Warning	▲	
Over Speed Shutdown		•
Over Voltage Shutdown (L-L, L-N, each phase)		•
Over Voltage Warning (L-L, L-N, each phase)	▲	
Protective Relay Shutdown Over Current		•
Protective Relay Shutdown Over Power		•
Protective Relay Shutdown Reverse Power		•
Protective Relay Shutdown Reverse VAR		•
Protective Relay Trip Over Current	▲	
Protective Relay Trip Over Frequency	▲	
Protective Relay Trip Over Power	▲	
Protective Relay Trip Over Voltage	▲	
Protective Relay Trip Reverse Power	▲	
Protective Relay Trip Reverse VAR	▲	
Protective Relay Trip Under Frequency	▲	
Protective Relay Trip Under Voltage	▲	
Remote Emergency Stop Shutdown		•
Under Frequency Shutdown		•
Under Frequency Warning	▲	
Under Voltage Shutdown (L-L, L-N, each phase)		•
Under Voltage Warning (L-L, L-N, each phase)	▲	
Weak Cranking Battery	▲	

* Function requires optional input sensors or kits

Figure 114 Common Warnings and Faults (factory-set)

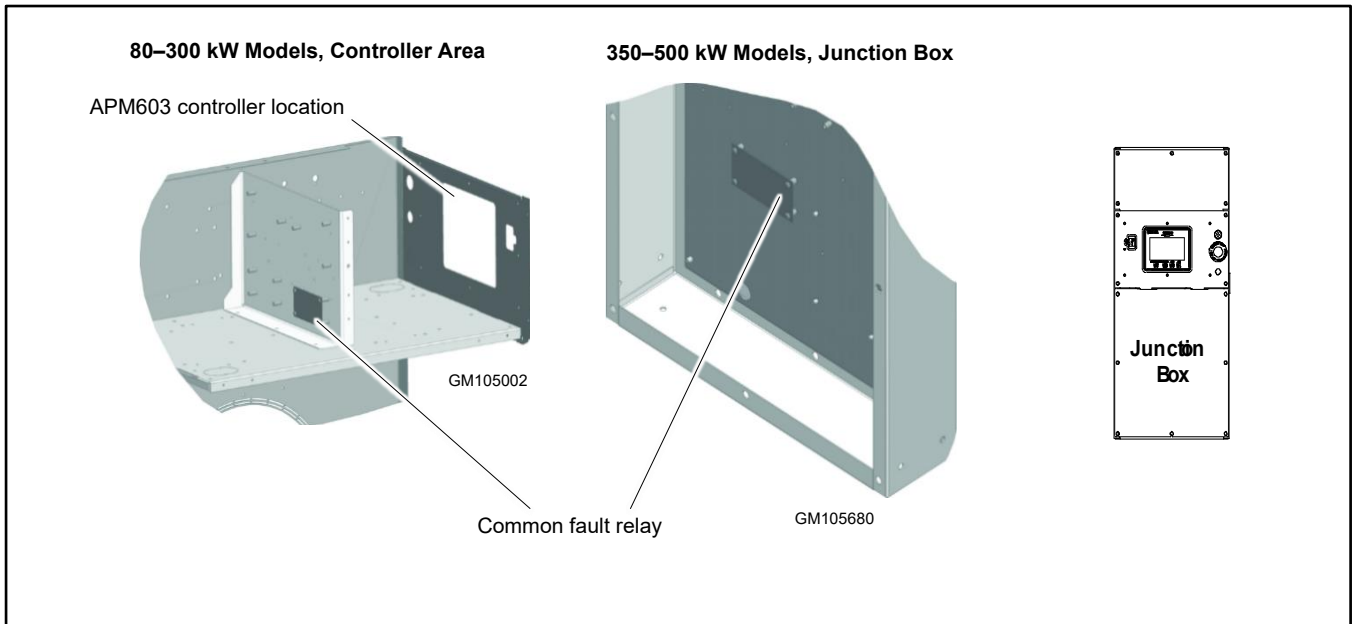

Figure 115 Optional Common Fault Relay Locations

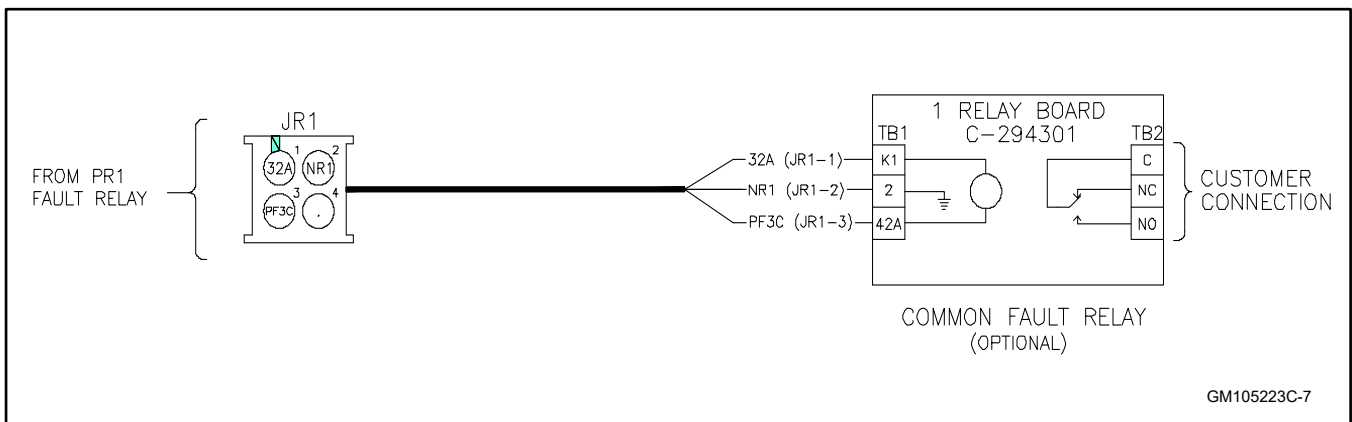

Figure 116 Common Fault Relay Wiring

9.2.4 Four-Input/Fifteen-Output Module

The optional four-input, fifteen-output module (see Figure 117 and Figure 118) provides normally open and normally closed contacts to activate warning devices and other user-provided accessories allowing remote monitoring of the generator set. Connect any controller fault output to the module. Typically, lamps, audible alarms, or other devices signal the fault conditions.

The I/O module is factory-installed and connected to the controller.

A personal computer with SiteTech™ software is required to assign the inputs and outputs. SiteTech™ is available only to authorized distributors and dealers.

The module has four digital inputs and two analog inputs. There are fourteen programmable relay outputs (K1–K14) and one common fault relay output (K15).

When a generator fault condition occurs, the contact kit relay is energized. The relay energization corresponds to the controller output being activated.

Check the electrical requirements of the user-supplied accessories prior to installation of the relay dry contact kit. User-supplied accessories require their own electrical source and must not exceed the relay contact ratings.

Connect to the normally open (NO) or normally closed (NC) terminals as required for each accessory. The relay contacts (K1 to K14) are rated:

- 10 amp @ 120 VAC
- 10 amp @ 28 VDC (max.)

- 0.01 amp @ 28 VDC (min.)

The common fault relay contact (K15) is rated:

- 500 mA @ 125 VAC
- 2 amp @ 30 VDC

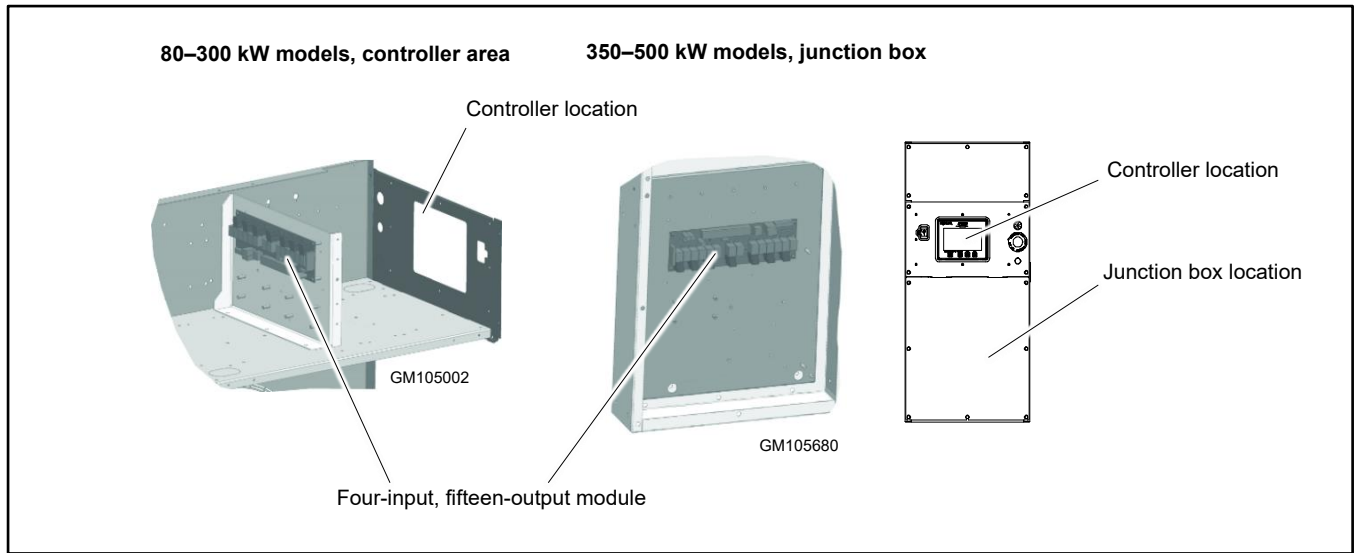

Figure 117 Optional Four-Input, Fifteen-Output Module Location (80-500 kW generator sets)

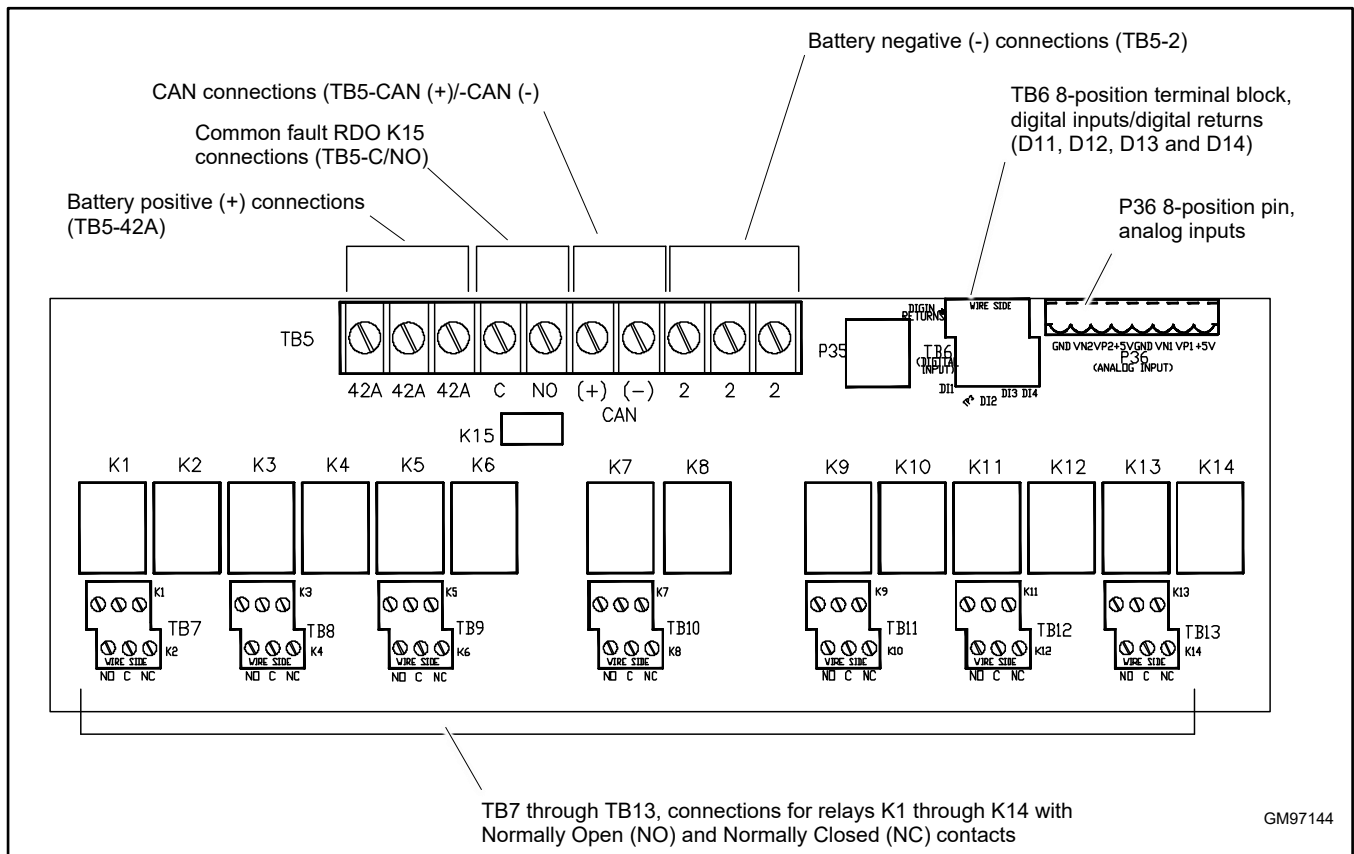



Figure 118 Four-Input, Fifteen-Output Module Customer Connections

For field connections, read the entire Electrical Connection procedure and perform the steps in the order shown. Observe applicable local and national electrical codes when installing the wiring system.

Observe the following safety precautions while making connections to the kit.

 WARNING	<p>Accidental starting. Can cause severe injury or death.</p> <p>Disconnect the battery cables before working on the generator set. Remove the negative (-) lead first when disconnecting the battery. Reconnect the negative (-) lead last when reconnecting the battery.</p>
	

Disabling the generator set. Accidental starting can cause severe injury or death. Before working on the generator set or equipment connected to the set, disable the generator set as follows: (1) Press the generator set off/reset button to shut down the generator set. (2) Disconnect the power to the battery charger, if equipped. (3) Remove the battery cables, negative (-) lead first. Reconnect the negative (-) lead last when reconnecting the battery. Follow these precautions to prevent the starting of the generator set by the remote start/stop switch.

Battery short circuits. Explosion can cause severe injury or death. Short circuits can cause bodily injury and/or equipment damage. Disconnect the battery before generator set installation or maintenance. Remove all jewelry before servicing the equipment. Use tools with insulated handles. Remove the negative (-) lead first when disconnecting the battery. Reconnect the negative (-) lead last when reconnecting the battery. Never connect the negative (-) battery cable to the positive (+) connection terminal of the starter solenoid. Do not test the battery condition by shorting the terminals together.

Connections

Leads 42A and 2 provide power to the relays. Do not use terminals 42A (+) or 2 (GND) on the controller connection kit terminal strip to supply voltage to user-supplied accessories. User-supplied DC accessories require separate leads connected directly to the battery for the voltage supply. Attach user-supplied 12/24-volt DC accessories to the battery positive (+) connection at the starter solenoid and to the battery negative (-) connection at the engine ground. The 120 VAC accessories require a user-supplied voltage source.

Note:

A maximum of three inputs may be connected to a single relay driver output. Inputs include dry contacts, remote annunciator, common failure alarm, A/V alarm, and shunt trip line circuit breaker.

Note:

Only one four-input, fifteen-output module can be connected to the controller.

Electrical Connection Procedure

1. Press the generator set master control OFF/RESET button.
2. Disconnect the power to the battery charger, if equipped.
3. Disconnect the generator set engine starting battery(ies), negative (-) lead first.
4. Remove the top panel of the controller connection box.
 - a. 80–300 kW models: Remove the top panel of the controller connection box.
 - b. 350–500 kW models: Remove the front panel from the junction box below the controller.
5. See Figure 119 for connections of analog inputs.
6. Select the normally open (NO) contacts of the relay, Form A dry contact, depending upon the application. Use a two-wire harness for the NO connections.
7. Supply two lengths of stranded wire to make leads long enough to connect the user-supplied device to the dry contact terminals and power supply. Use color-coded wire for easy identification. Make leads long enough to allow for walls, ductwork, and other obstructions. Use separate conduit for the dry contact wiring.

8. **12/24-Volt DC Devices.** Attach the user-supplied 12/24-volt DC accessories to the starting battery positive (+) connection at the starter solenoid and to the battery negative (-) connection at the engine ground. Otherwise, use a separate 12/24-volt DC supply. Do not use terminals 42A and 2 on the controller connection kit terminal strip to supply the voltage to the relay contacts. Supply separate leads connected directly to the battery for the supply voltage. The circuit must include fuse or circuit breaker protection.
9. **120-Volt AC Devices.** Connect the user-supplied accessories to a separate 120-volt AC power supply. The circuit must include fuse or circuit breaker protection.
10. Connect the user-supplied device per the Instructions and/or schematic supplied with the device to a power source and to the dry contact terminals. Cut the user-supplied leads to length, strip lead ends, crimp on spade terminals (not supplied), and connect the leads to the relay contact screw terminals. Route the wiring for the relay dry contacts away from the generator set output leads.
11. Repeat 6 for the remaining dry contact relays.
12. Replace the cover on the controller connection box.
13. Check that the generator set is in the OFF mode.
14. Reconnect the generator set engine starting battery, negative (-) lead last.
15. Reconnect power to the battery charger, if equipped.

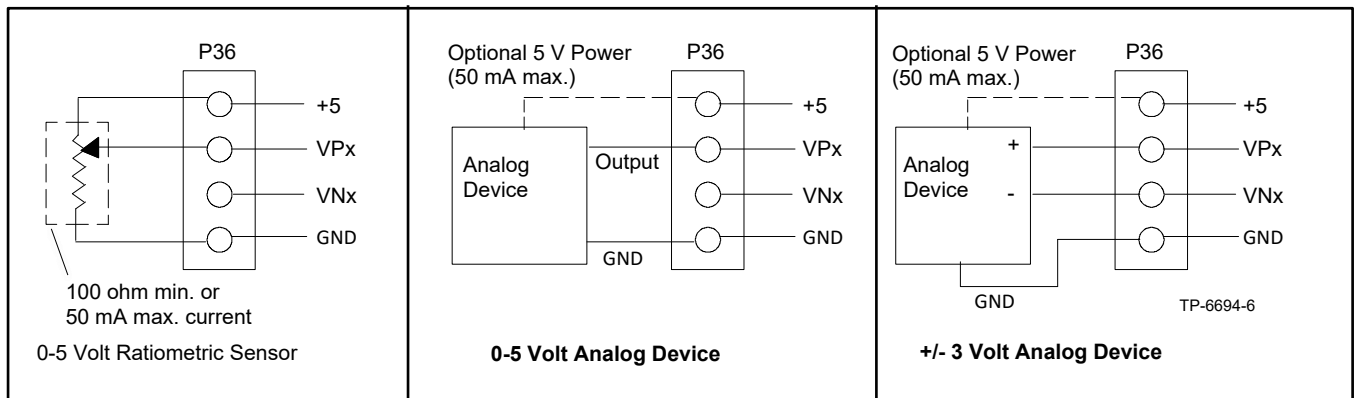

Figure 119 Input/output Module Analog Input Connections, P36

Program the inputs and outputs using SiteTech™

Use a computer with SiteTech™ software to assign functions to digital and analog inputs and outputs. Each input and output corresponds to a controller connection. Verify that the settings are appropriate for the connected sensor, switch, or equipment. Do not change factory-set inputs and outputs without verifying the input and output connections.

Refer to Introduction-List of Related Materials for the SiteTech™ Software Operation Manual part no.

SiteTech™ input and output parameters C1 through C14 are designated for use on the optional 15-relay dry contact board. See Figure Optional Inputs and Outputs with I/O Module Board.

Note:

See the previous figure, Input/15-Output Module Customer Connections, for P36 and TB7-TB13 locations.

Test the relays

Verify the dry contact relay function by using the following procedure when troubleshooting.

1. Remove the user-supplied device wiring from the relay dry contact terminals.
2. Test the relay operation by connecting an ohmmeter across the NO and C terminals on the relay terminal strip.
3. Use a jumper wire to ground the selected fault terminal on the controller connection terminal strip. The relay contacts should close and the ohmmeter should display a low resistance reading (continuity).
4. Install the user-supplied device wiring on the relay dry contact output terminals

SiteTech I/O Name	Optional Dry Contact Board Connection
Analog Input 1	P36 Analog Input VN1/VP1
Analog Input 2	P36 Analog Input VN2/VP2
Digital Input 1	TB6 DI1
Digital Input 2	TB6 DI2
Digital Input 3	TB6 DI3
Digital Input 4	TB6 DI4
Digital Output K1	TB7 K1
Digital Output K2	TB7 K2
Digital Output K3	TB8 K3
Digital Output K4	TB8 K4
Digital Output K5	TB9 K5
Digital Output K6	TB9 K6
Digital Output K7	TB10 K7
Digital Output K8	TB10 K8
Digital Output K9	TB11 K9
Digital Output K10	TB11 K10
Digital Output K11	TB12 K11
Digital Output K12	TB12 K12
Digital Output K13	TB13 K13
Digital Output K14	TB13 K14

Figure 120 Optional Inputs and Outputs with I/O Module Board

9.2.5 Digital Input/Output Modules

The optional digital 8 input/output module (D8IOM) is available for 750-2000REOZMD and 1250-1600ROZMC generator sets equipped with the APM603 controller. Each D8IOM provides 8 input and 8 output connections. Two optional D8IOMs can be installed on the generator set. See Figure 121 for the D8IOM location.

The I/O module is factory-installed and connected to the controller.

The D8IOM provides normally open and normally closed contacts to activate warning devices and other user-provided accessories allowing remote monitoring of the generator set. Typically, lamps, audible alarms, or other devices signal the fault conditions. A personal computer with SiteTech™ software is required to assign the inputs and outputs. SiteTech™ is available only to authorized distributors and dealers.

For load management connections and setup, refer to APM603 Commissioning Manual TP-7131.

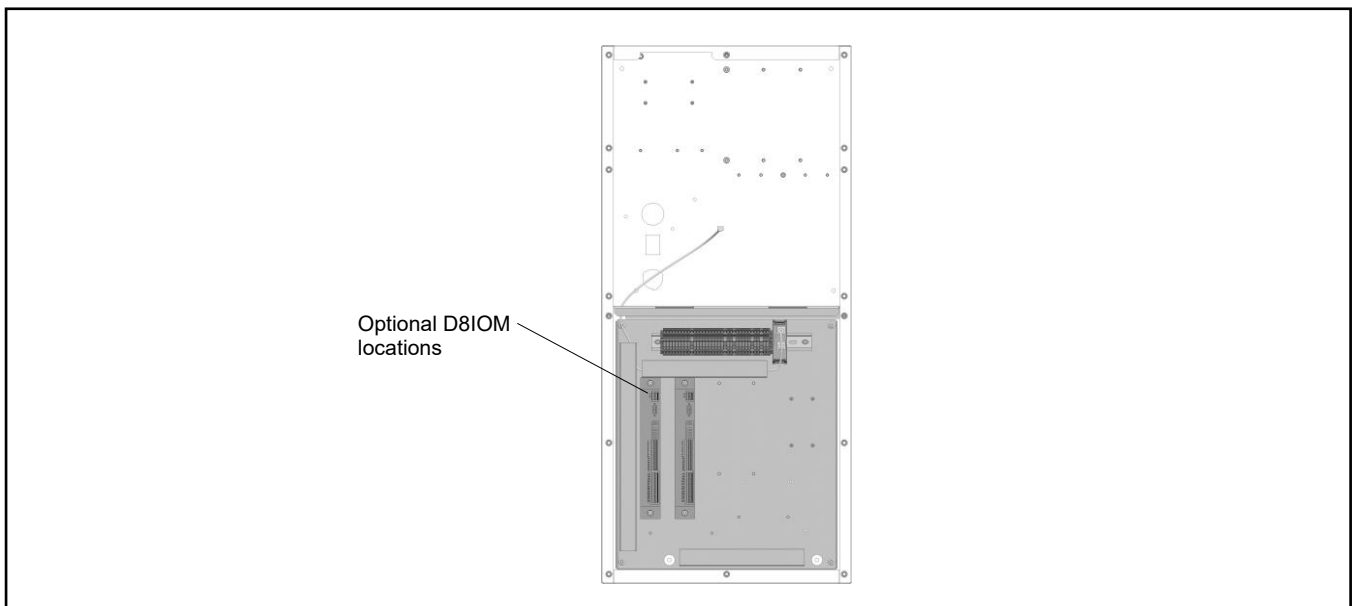

Figure 121 Digital 8 Input/Output Module (D8IOM), Mitsubishi Models

The Digital 8 Input/Output Module Kit is available as an optional accessory. The modules are factory-installed in the customer connection box. Module power and CAN communication with the controller are factory-connected. The module CAN address is factory-set. Do not change the CAN address DIP switch settings.

The original DIOM provides 8 digital inputs and 4 digital (relay) outputs. The updated D8IOM adds more outputs, providing 8 digital inputs and 8 digital (relay) outputs. See Figure 122 to compare the original and updated designs. Full support of the new D8IOM requires firmware version 3.6 or later for the APM603 controller and version 1.11 or later for the APM802 controller.

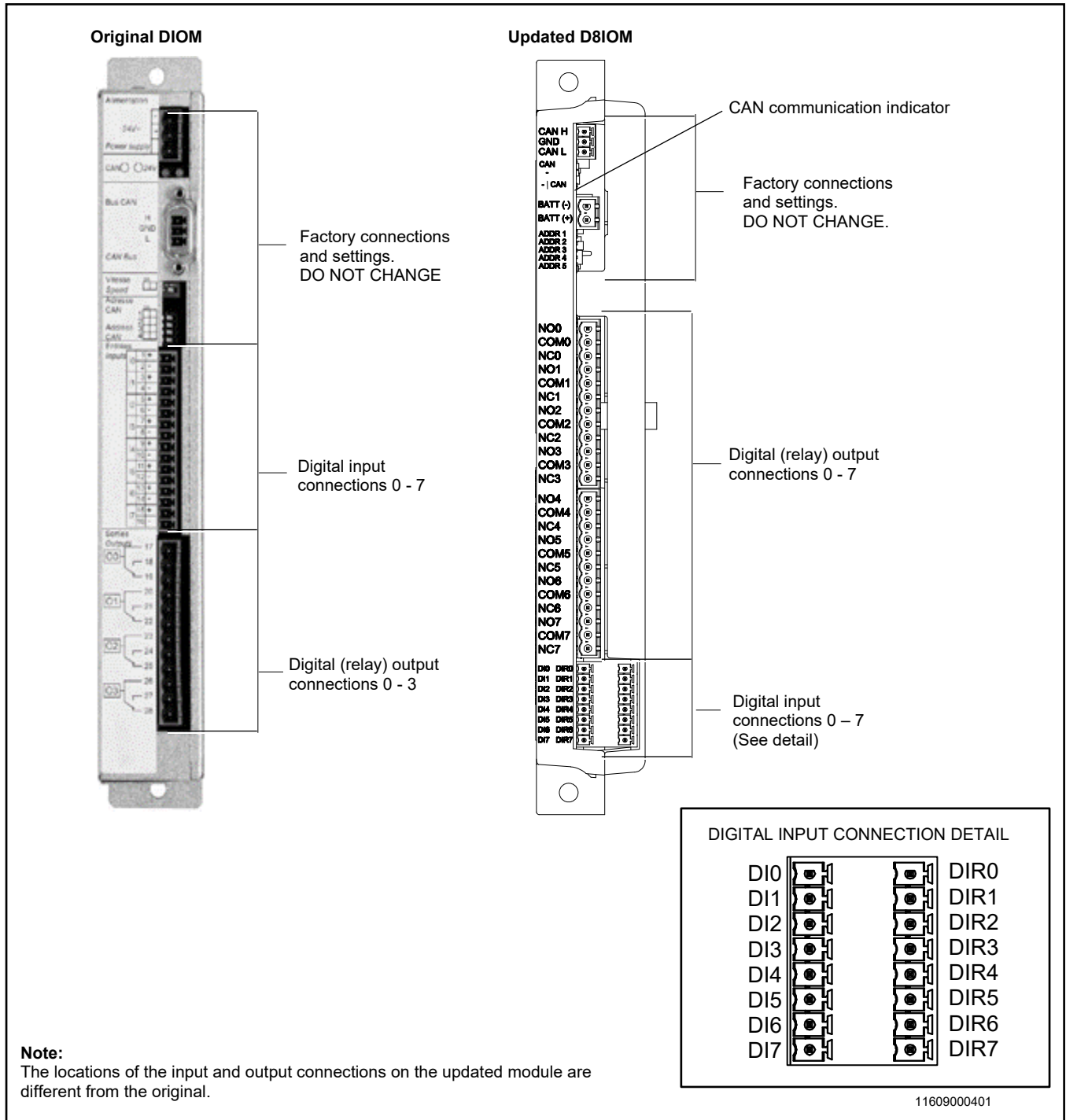

Figure 122 Digital Input/Output Modules, Original and Updated

See the table below for contact specifications. Refer to the D8IOM specification sheets, UL and CE versions, for additional specifications.

Inputs	
Number of inputs	8 configurable inputs
Input voltage	12 VDC/24VDC
Contacts	Normally open (NO). Activates on ground connection
Connection	0.75 to 1.5 mm ² (20AWG-16AWG)
Inputs isolated	Yes
Outputs	
Number of outputs	Binary outputs for power: 8
Contacts	Form C, rated 3 A @ 250 VAC (UL version) Form C, rated 3 A @ 30 VDC (CE version)
Connections	0.75 to 1.5 mm ² (20AWG-16AWG)
Voltage	250 VAC maximum (UL version) 30 VDC (CE version)
Current	3 Amps maximum
Power	375 VA maximum (UL version) 90 W (CE version)
Number of operation cycles at full load	100 000
Minimum current:	10 mAmps

Figure 123 Input and Output Specifications (updated D8IOM)

The updated module is equipped with one diagnostic LED to show the status of CAN communication between the module and the generator controller. See Figure 124.

LED Description	LED Operation
CANbus 1 Communication LED	Flashing green: CAN communication is consistent. Steady green: No CAN communication. Off: No CAN communication.

Figure 124 CAN Communication Indicator

The DIOM kit includes two digital input/output modules, referred to as DIOM 1 and DIOM 2. The digital inputs and outputs on DIOM 1 and DIOM 2 can be configured by an authorized service technician. Contact your distributor with your requirements for digital inputs and outputs.

9.2.6 Fuel Level Sender and Fuel Leak Alarm

Fuel Level Sender

The fuel level sender is included with the subbase fuel tank. The fuel level sender connects to quick connects QCON5 and QCON6 in the generator set junction box. See Figure 125 and Figure 126 for the connections.

Fuel Leak Alarm

If the tank is equipped with an optional fuel leak alarm, connect the alarm to quick connects QCON7 and QCON8 in the generator set junction box. See Figure 125 for the wiring recommendations and Figure 126 for the connections.

Wiring Recommendation	
Gauge	mm(ft.)
18-20	30.5(100)
14	153(500)
10	305(1000)

Figure 125 Wiring Recommendation

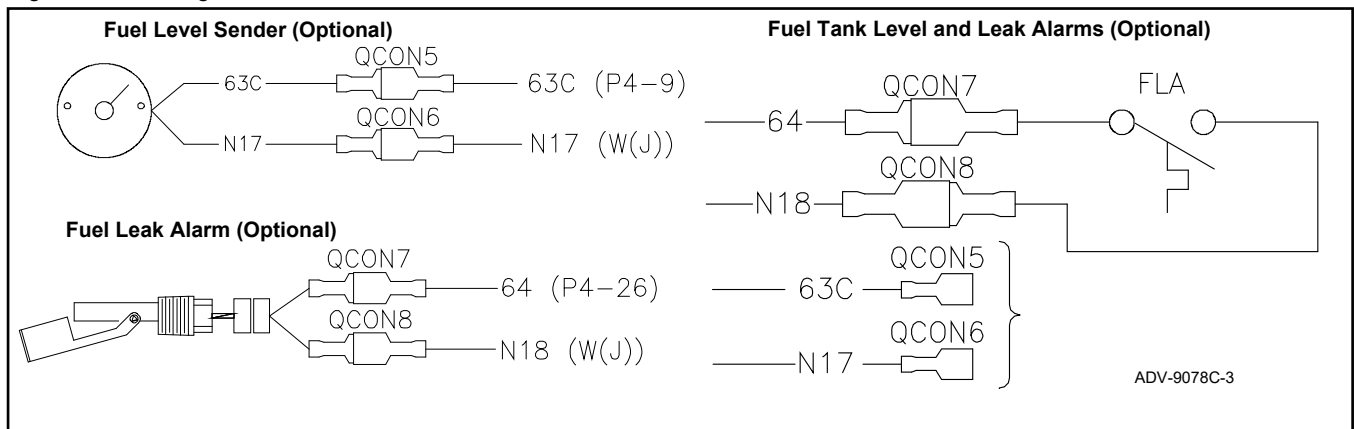

Figure 126 Low Fuel Level Sender and Fuel Leak Alarm Connections

9.2.7 Remote Emergency Stop Kit

The emergency stop kit allows immediate shutdown of the generator set from a remote location. See the following figures for connection details. Install the emergency stop switch in a location that is easily accessible by operating personnel. Connect as many emergency stop switches as required; however, connect multiple switches in series so the system functions correctly.

Two emergency stop kits are available. See the image below.

- For the emergency stop switch, use the single glass piece located inside the switch for replacement and order additional glass pieces as service parts. See the respective operation manual for the Emergency Stop Switch Reset Procedure. See the following subsection, "Accessory Connections," for terminal identifications.
- The lockable emergency stop kit allows the installation of a lockout/tagout device to lock the switch in the STOP position. Insert a locking device through the openings in the shroud to prevent resetting the switch.

Refer to the instructions provided with the kit for installation instructions.

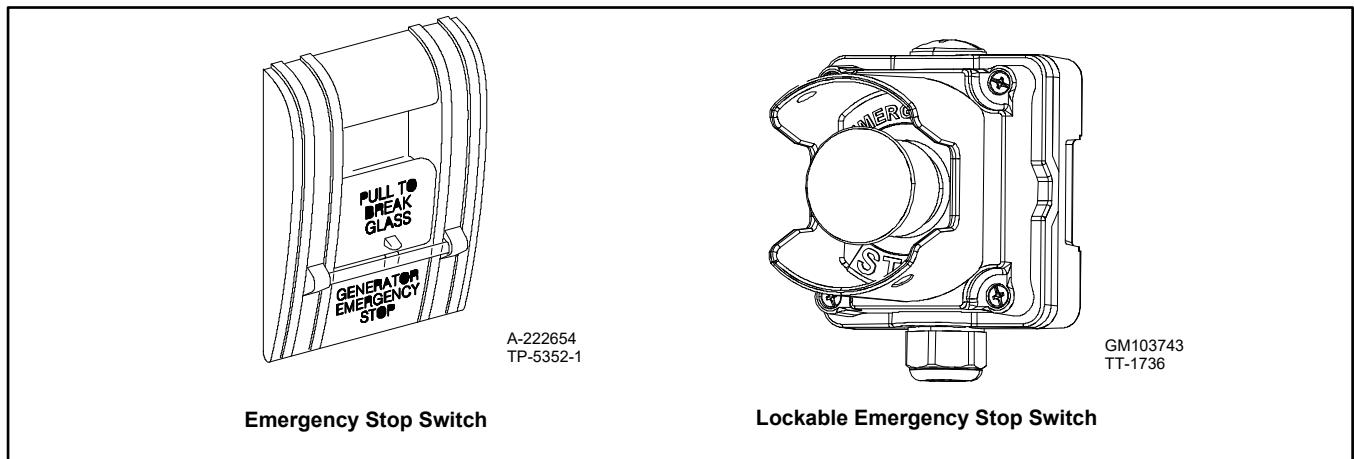

Figure 127 Emergency Stop Kits

See the figure below for typical connections. Refer to the generator set wiring diagram for your model. Remove the jumper across the E-stop connections when installing the switch.

Also see subsection Accessory Connections.

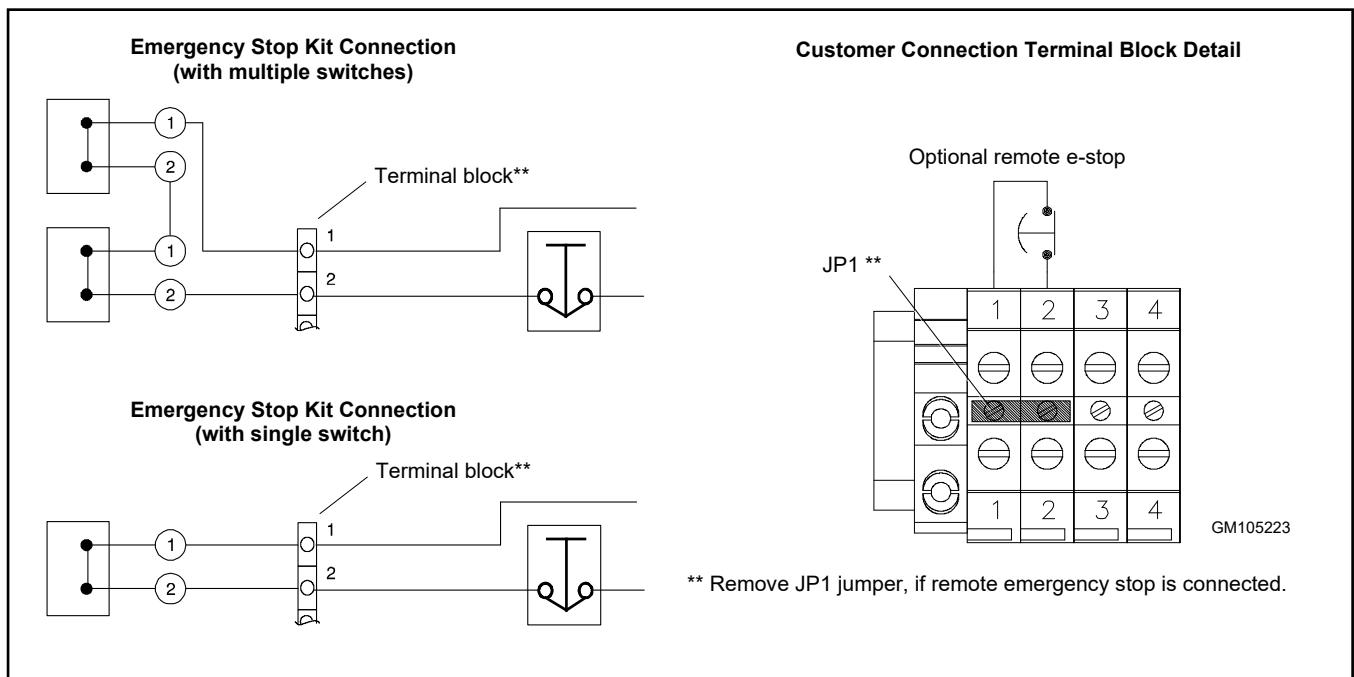

Figure 128 Remote Emergency Stop Kit Connections

9.2.8 Emergency Battle Mode

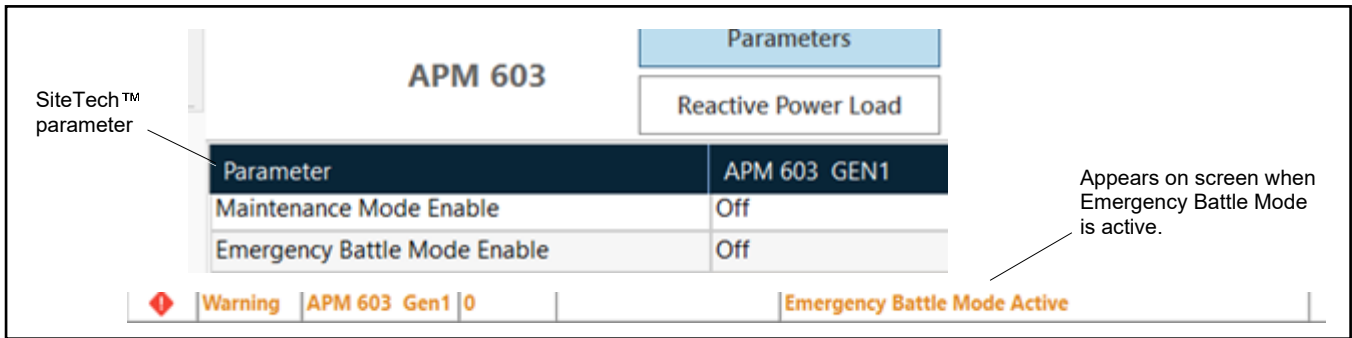

Figure 129 SiteTech™ Parameters and Onscreen Warning

Note that any damage to the generator set resulting from being placed in Emergency Battle Mode is not covered by warranty.

When uninterrupted power is essential for critical emergency operation, **Emergency Battle Mode** overrides most shutdowns and warnings except for emergency stop, overspeed, maintenance mode, and shutdown faults from the ECU. This operation allows the generator set to function when continuous power is more important than the potential damage to the generator set.

Emergency battle mode requires:

- Four-input, fifteen-output module (15-600 kW generator sets) or the digital I/O module (700-4000 kW generator sets)
- Controller firmware version 3.9
- Controller configuration version 3.9 (with Mitsubishi engines); 3.8 [with all other models, John Deere, Volvo, Doosan, and Rehlko engines (KG, KDI, KD series)]
- Output status indicator or status light (optional)

Note: Use SiteTech™ to verify the configuration version under the Genset Info menu.

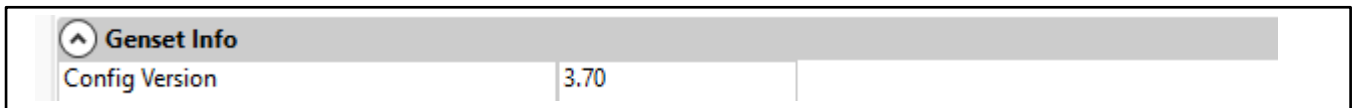
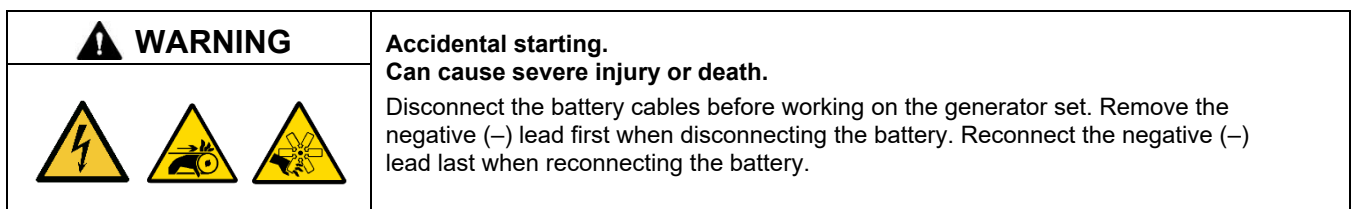

Figure 130 Config Version in SiteTech™

Emergency Battle Mode Enable parameter must be enabled by an authorized service technician. When emergency battle mode is enabled, the controller monitors the designated closed-circuit input. The monitored circuit is typically connected to essential equipment that needs emergency battle mode support from the generator set and activates emergency battle mode by opening the input. When activated, an on-screen prompt (Emergency Battle Mode Active Warning) appears on the APM603 controller.

While in Battle Mode, the engine ECU determines if a shutdown override request is implemented or ignored. As a result, a generator set in emergency battle mode may still shut down in certain instances depending on the specific engine ECU.



Disabling the generator set. Accidental starting can cause severe injury or death. Before working on the generator set or equipment connected to the set, disable the generator set as follows: (1) Press the generator set off/reset button to shut down the generator set. (2) Disconnect the power to the battery charger, if equipped. (3) Remove the battery cables, negative (-) lead first. Reconnect the negative (-) lead last when reconnecting the battery. Follow these precautions to prevent the starting of the generator set by the remote start/stop switch.

NOTICE

Emergency Battle Mode. Damage is not covered under warranty.

Emergency battle mode can cause severe or permanent damage to the generator set by overriding shutdown faults and warnings. Be aware of the risks to the generator set before enabling emergency battle mode.

9.2.8.1 Installation Procedure

9.2.8.1.1 Remove the Generator Set from Service

1. Turn off the generator set by pressing the OFF/RESET button on the generator set controller or placing the generator set master switch in the OFF position.
2. Press the Emergency Stop (E-Stop) button on the generator set, if equipped.
3. Disconnect the power to any generator set accessories such as a block heater, if equipped.
4. Disconnect the generator set engine starting battery (ies), negative (-) lead first.
5. Disconnect the generator set from load by opening the line circuit breaker.

9.2.8.1.2 Setup

Emergency battle mode can be used with either the four-input, fifteen-output module (under 600 kW) or the digital I/O module (700 kW and above). Use the following instructions to complete the installation for emergency battle mode.

Note:

The customer-supplied device for emergency battle mode is typically something like a water pump. Dry contacts for the customer supplied device are connected to the digital inputs for the APM603 controller. When the customer supplied device is activated, the controller will enter battle mode. The digital inputs shown below are factory preset for emergency battle mode.

1. Verify that the controller firmware is updated.

Note:

Always back up the controller parameters before updating the controller.

2. Use the following steps to connect the wiring harness from the customer-supplied device to either the four-input, fifteen-output module or the digital I/O module.

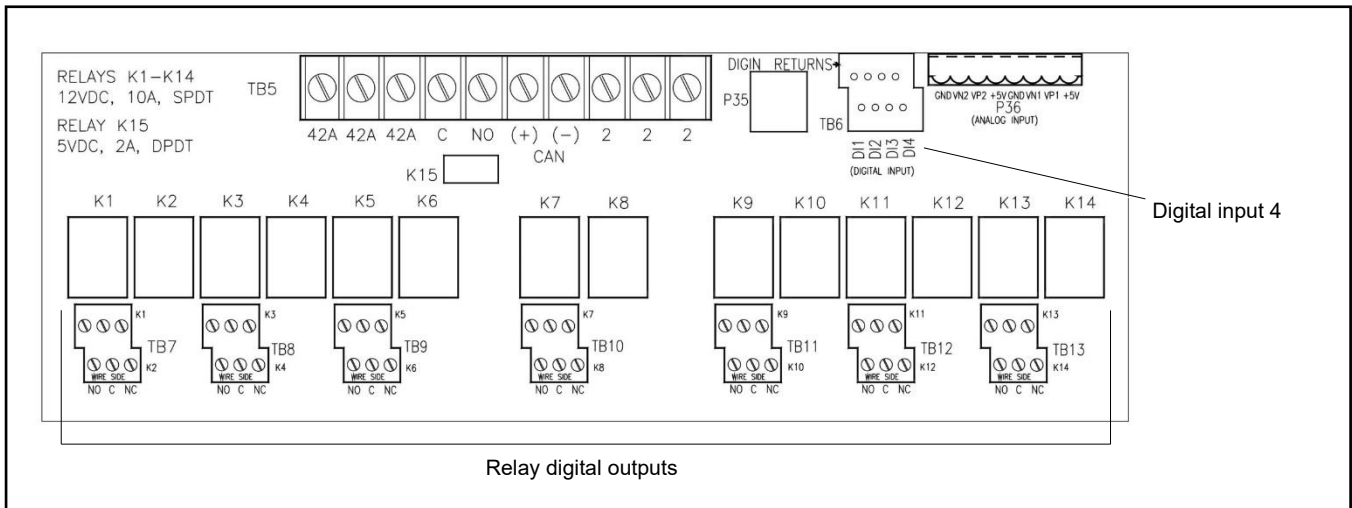

Figure 131 Four-input, Fifteen-output Module

- a. For the four-input, fifteen-output module, connect the digital outputs from the customer-supplied device to digital input 4 (DI4) on terminal block 6 (TB).

The relay contacts (K1 to K14) are rated:

- 10 amp @ 120 VAC

- 10 amp @ 28 VDC (max.)
- 0.01 amp @ 28 VDC (min.)

Note:

Any available output can be programmed in SiteTech™ to correspond to the digital input.

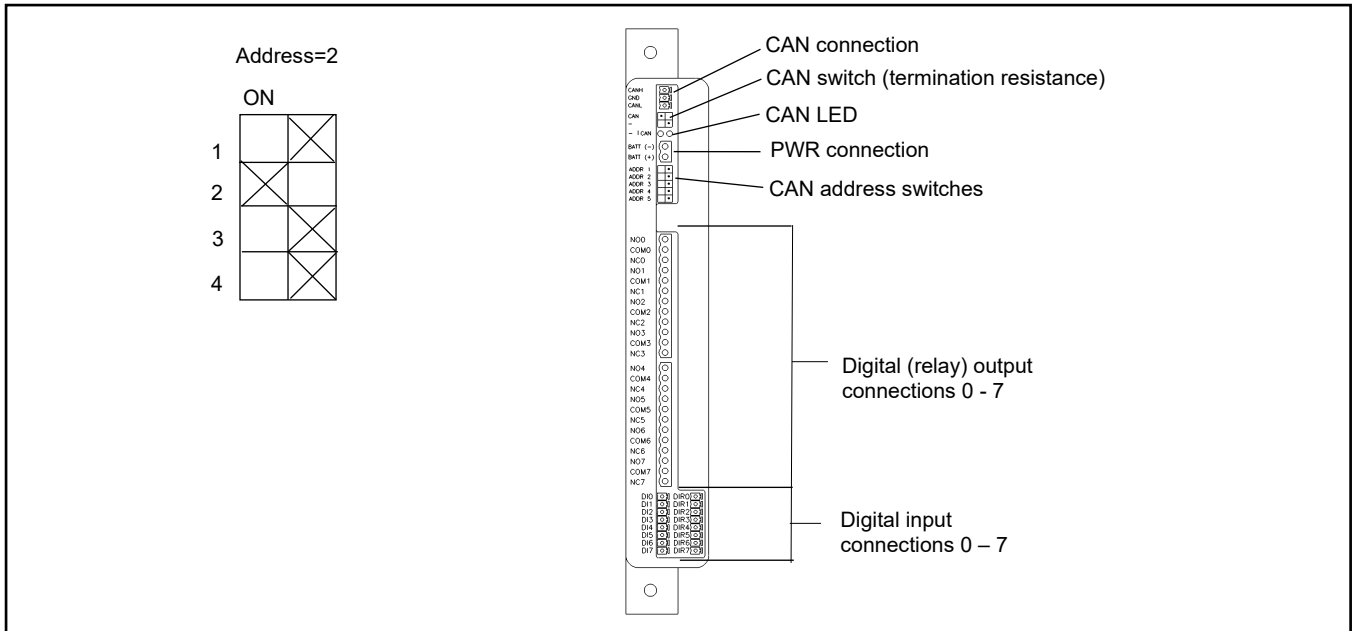

Figure 132 Digital Input/Output Module

- b. For the digital I/O module:
 - i. Set the CAN address switches to address 2.
 - ii. Connect the digital outputs from the customer-supplied device to digital input 7 (DI7).

Note: See the table below for D8IOM contact specifications.

Inputs	
Number of inputs	8 configurable inputs
Input voltage	12 VDC/24VDC
Contacts	Normally open (NO). Activates on ground connection
Connection	0.75 to 1.5 mm ² (20AWG-16AWG)
Inputs isolated	Yes
Outputs	
Number of outputs	Binary outputs for power: 8
Contacts	Form C, rated 3 A @ 250 VAC (UL version) Form C, rated 3 A @ 30 VDC (CE version)
Connections	0.75 to 1.5 mm ² (20AWG-16AWG)
Voltage	250 VAC maximum (UL version) 30 VDC (CE version)
Current	3 Amps maximum
Power	375 VA maximum (UL version) 90 W (CE version)
Number of operation cycles at full load	100 000
Minimum current:	10 mAmps

Figure 133 Input and Output Specifications (updated D8IOM)

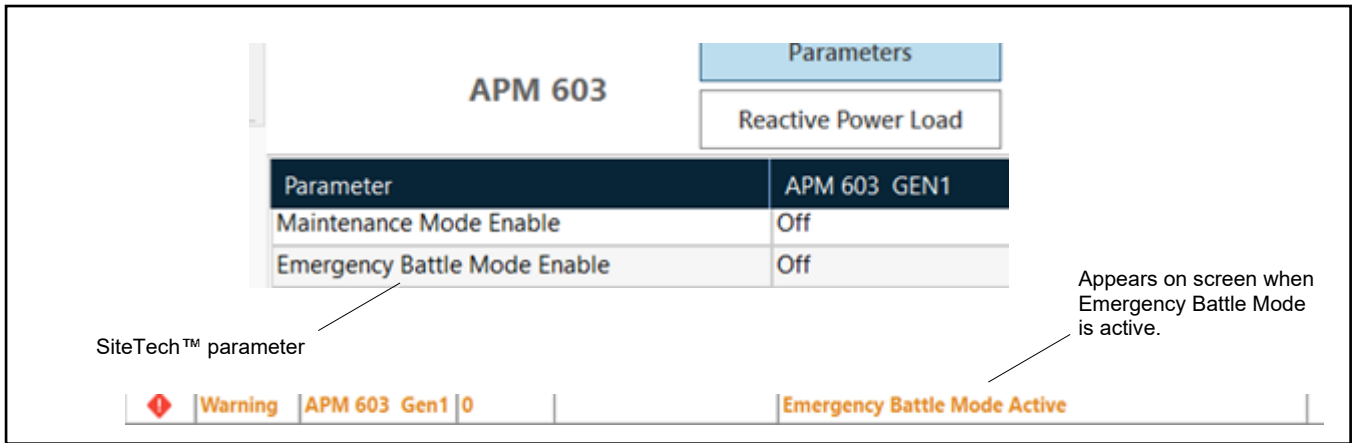

Figure 134 SiteTech™ Parameters and Onscreen Warning

- Using SiteTech™, enable the parameter, **Emergency Battle Mode Enable**.

Important: In SiteTech™, the following prompt will warn about warranty exclusions.

Warning: Operating a generator in Battle Mode will bypass some faults and prevent the generator from shutting down. As a result, the operation of battle mode may void your warranty. Do you want to continue activating Battle Mode?

9.2.8.1.3 Restore the Generator Set to Service

- Check that the generator set is OFF.
- Check that the Emergency Stop button is activated.
- Reconnect the generator set engine starting battery, negative (–) lead last.
- Reconnect the power to any generator set accessories such as a battery charger or block heater.
- Reconnect the generator set to load by closing the line circuit breaker.
- Reset the Emergency Stop button.
- Clear the Emergency Stop fault on the controller.
- For normal operation, move the manual key switch to AUTO and remove the key, if equipped.
- Return the generator set to normal operation by pressing the generator set master control AUTO or RUN button or by placing the generator set master switch in the AUTO or RUN position, as required.

9.2.9 Maintenance Mode

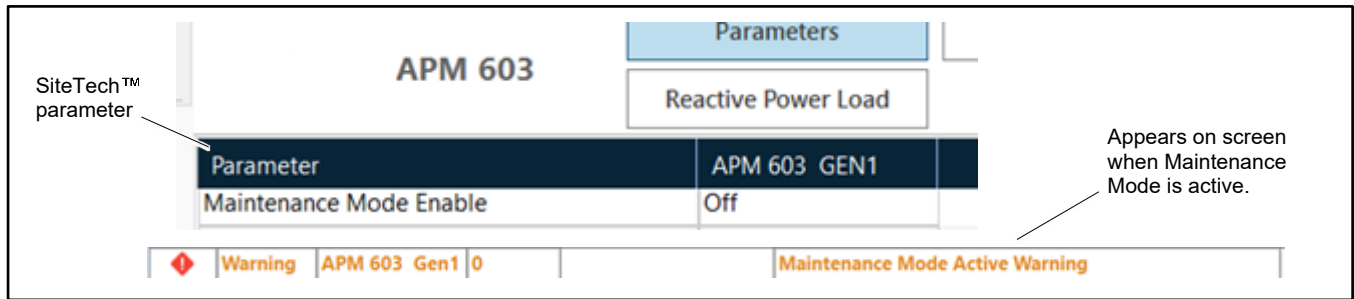

Figure 135 SiteTech™ Parameters and Onscreen Warning

For maintenance or service procedures that must be performed while the generator set is operating, **Maintenance Mode**, when engaged, lowers the overcurrent threshold and provides extra protection in dangerous situations. The overcurrent level is adjustable from 0-150% of rated current. The user can set the parameter low enough to protect and high enough not to trip under normal circumstances. Note that factory setting for overcurrent is typically 10% of rated current.

Maintenance mode does not alter breaker trip curves. Trip speed is dependent on the shunt trip speed of the breaker making the trip speed constant on all overcurrent settings on the controller. The controller reaction takes place 30 ms after detecting that the current exceeds the specified threshold.

An Arc flash study and selective coordination of the system is recommended to determine that maintenance mode settings will reduce incident energy exposure to levels that can be mitigated by the required personal protective equipment. The resulting study will determine maximum allowable arc current and thus dictate the overcurrent setting in maintenance mode.

Maintenance mode requires:

- Four-input, fifteen-output module (15-600 kW generator sets) or the digital I/O module (700-4000 kW generator sets)
- Shunt trip kit
- Physical switch to operate maintenance mode
- Controller firmware version 3.9
- Controller configuration version 3.9 with Mitsubishi engines; version 3.8 with all other engines [John Deere, Volvo, Doosan, and Rehlko (KG, KDI, KD series)]
- Output status indicator or status light (optional)

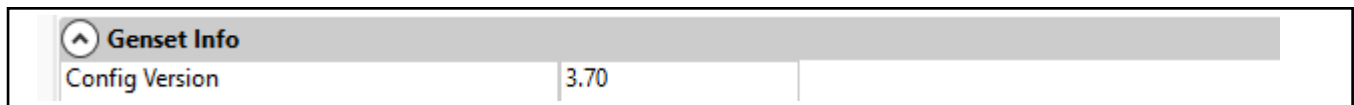



Figure 136 Config Version in SiteTech™

Maintenance Mode Enable parameter must be enabled by an authorized service technician. The service technician must also specify the maintenance mode trip level threshold. When maintenance mode is enabled and the digital input circuit is open, indicating a currently active feature, the controller monitors the designated closed-circuit input. The monitored circuit is typically connected to a physical switch that opens the circuit and activates maintenance mode. When activated, an on-screen prompt (Maintenance Mode Active Warning) appears on the APM603 controller.

 WARNING	Accidental starting. Can cause severe injury or death. Disconnect the battery cables before working on the generator set. Remove the negative (-) lead first when disconnecting the battery. Reconnect the negative (-) lead last when reconnecting the battery.
	

Disabling the generator set. Accidental starting can cause severe injury or death. Before working on the generator set or equipment connected to the set, disable the generator set as follows: (1) Press the generator set off/reset button to shut down the generator set. (2) Disconnect the power to the battery charger, if equipped. (3) Remove the battery cables, negative (-) lead first. Reconnect the negative (-) lead last when reconnecting the battery. Follow these precautions to prevent the starting of the generator set by the remote start/stop switch.

9.2.9.1 Installation Procedure

9.2.9.1.1 Remove the Generator Set from Service

6. Turn off the generator set by pressing the OFF/RESET button on the generator set controller or placing the generator set master switch in the OFF position.
7. Press the Emergency Stop (E-Stop) button on the generator set, if equipped.
8. Disconnect the power to any generator set accessories such as a block heater, if equipped.
9. Disconnect the generator set engine starting battery (ies), negative (-) lead first.
10. Disconnect the generator set from load by opening the line circuit breaker.

9.2.9.1.2 Setup

Maintenance mode can be used with either the four-input, fifteen-output module (under 600 kW) or the digital I/O module (700 kW and above). A specific digital input and output are dedicated for use with maintenance mode. If maintenance mode is not used, the digital input and output are not dedicated and are available for other uses. Use the following instructions to complete the installation for maintenance Mode.

Note:

Refer to the sections in the generator set installation manual for additional information about connecting to four-input, fifteen-output module. Refer to the controller service manual for additional information about updating the controller firmware.

1. Verify that the controller firmware is updated.

Note:

Always back up the controller parameters before updating the controller.

2. Use the following steps to connect the wiring harness to either the four-input, fifteen-output module or the digital I/O module.

Note:

A switch is connected to a specified digital input on the APM603 controller. When the switch is activated, the controller will enter maintenance mode. The digital inputs shown below are factory preset for maintenance mode.

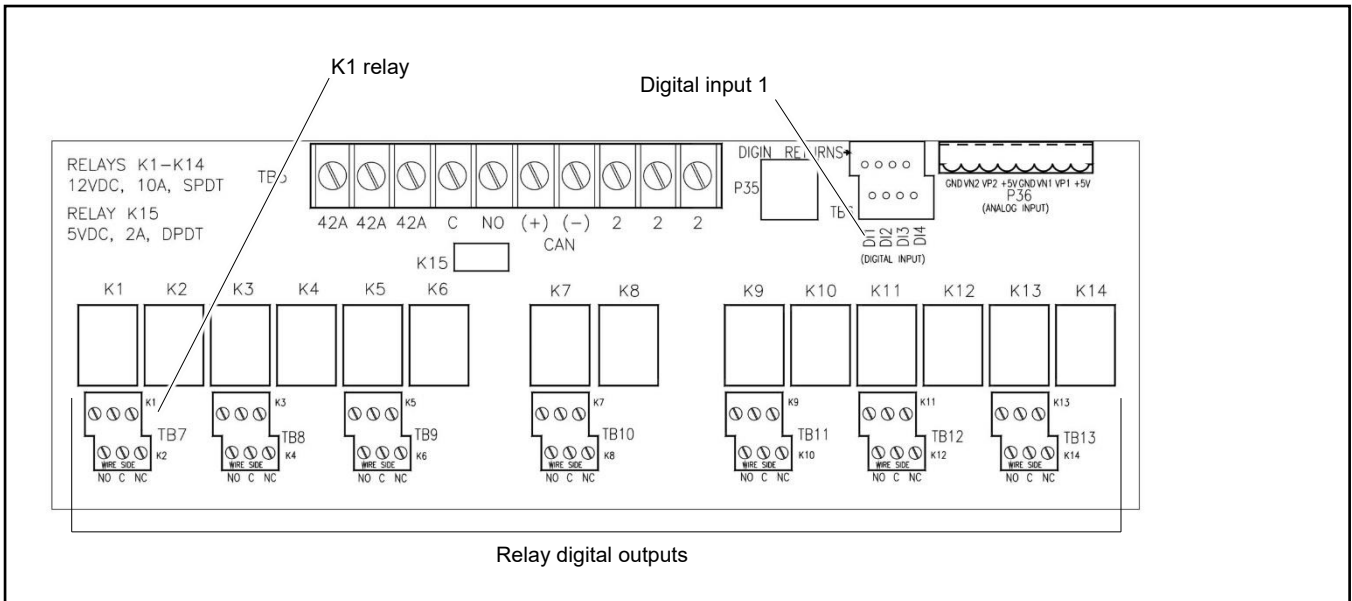

Figure 137 Four-input, Fifteen-output Module

a. For the four-input, fifteen-output module:

- i. Connect the normally closed operation switch to the input and return terminals on digital input 1 (DI1), terminal block 6 (TB).
- ii. If desired, connect an optional remote annunciation or status indicator light to the normally-closed output for the K1 relay, terminal block 7 (TB7).

The relay contacts (K1 to K14) are rated:

- 10 amp @ 120 VAC
- 10 amp @ 28 VDC (max.)
- 0.01 amp @ 28 VDC (min.)

Note:

Any available output can be programmed in SiteTech™ to correspond to the digital input.

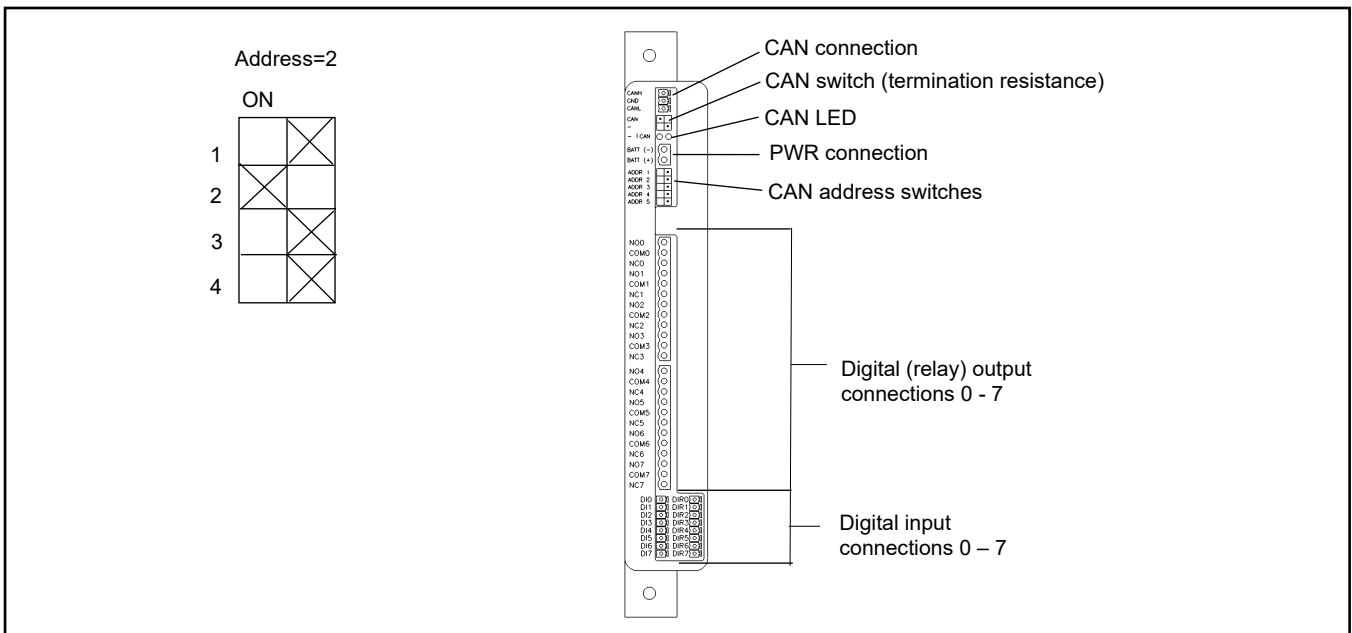

Figure 138 Digital Input/Output Module

b. For the digital I/O module

- i. Set the CAN address switches to address 2.
- ii. Connect an operation switch (normally closed) to the input and return terminals on digital input 6 (DI6):
- iii. If desired, connect an optional remote annunciation or status indicator light to the normally-closed connection for digital output 7 (DO7).

See the table below for D8IOM contact specifications.

Inputs	
Number of inputs	8 configurable inputs
Input voltage	12 VDC/24VDC
Contacts	Normally open (NO). Activates on ground connection
Connection	0.75 to 1.5 mm ² (20AWG-16AWG)
Inputs isolated	Yes
Outputs	
Number of outputs	Binary outputs for power: 8
Contacts	Form C, rated 3 A @ 250 VAC (UL version) Form C, rated 3 A @ 30 VDC (CE version)
Connections	0.75 to 1.5 mm ² (20AWG-16AWG)
Voltage	250 VAC maximum (UL version) 30 VDC (CE version)
Current	3 Amps maximum
Power	375 VA maximum (UL version) 90 W (CE version)
Number of operation cycles at full load	100 000
Minimum current:	10 mAmps

Figure 139 Input and Output Specifications (updated D8IOM)

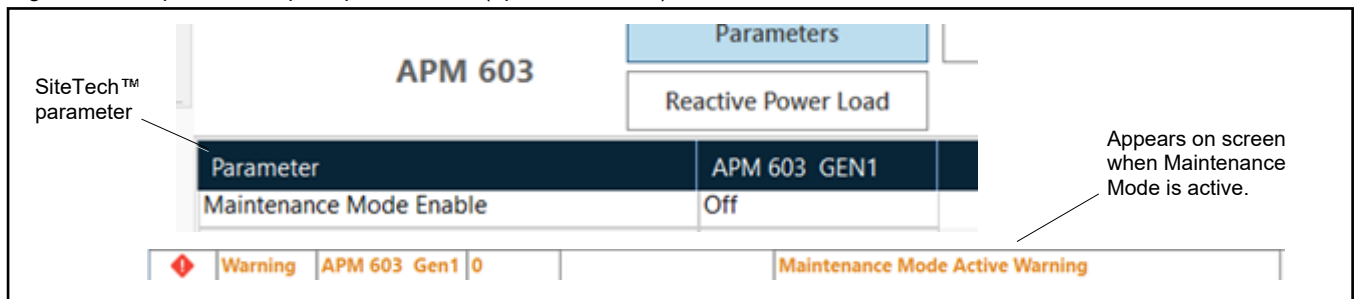

Figure 140 SiteTech™ Parameters and Onscreen Warning

3. Use SiteTech™ to enable the parameter, **Maintenance Mode Enable**.
4. Use the controller user interface (under Event Configuration menu) or SiteTech™ to set the maintenance overcurrent parameter, **Maintenance Over Current Shutdown Limit**, as desired (0–150% of rated current).

Note: Maintenance Over Current Shutdown Limit should be set lower than the Over Current Shutdown Limit parameter.

9.2.9.1.3 Restore the Generator Set to Service

1. Check that the generator set is OFF.
2. Check that the Emergency Stop button is activated.
3. Reconnect the generator set engine starting battery, negative (–) lead last.
4. Reconnect the power to any generator set accessories such as a battery charger or block heater.
5. Reconnect the generator set to load by closing the line circuit breaker.
6. Reset the Emergency Stop button.
7. Clear the Emergency Stop fault on the controller.
8. For normal operation, move the manual key switch to AUTO and remove the key, if equipped.
9. Return the generator set to normal operation by pressing the generator set master control AUTO or RUN button or by placing the generator set master switch in the AUTO or RUN position, as required.

9.2.10 Remote Serial Annunciator (RSA III)

Refer to the RSA III installation instructions, TT-1625.

RSA III is an annunciator panel offered in several kit configurations to support power equipment. The RSA III is a remote serial annunciator that monitors the condition of the generator set and/or ATS from a remote location. The RSA III alerts the operator through visual and audible signals using LED indication and a horn. An alarm silence and lamp test switch are included.

The RSA III meets NFPA 110, Level 1 (2005) applications that require remote controls and alarms to be powered by a storage battery such as the engine starting battery. AC adaptor kit GM62466-KP1 is available when NFPA is not required.

A personal computer (PC) with SiteTech™ software is required to make the RSA III functional. SiteTech™ is available to authorized distributors and dealers.

An RSA III annunciator can be used for a single generator set or with a combination of a generator set and automatic transfer switch(es). In systems using more than a single RSA III, one must be designated as the master device to broadcast to additional RSA III annunciators, designated as slave devices. Up to five RSA III slave devices can be used with an RSA III master device. All RSA III annunciators are factory set as the master device, but can be changed to a slave device using a personal computer (PC) and SiteTech™ software that connects to the RSA III front panel via a universal serial bus (USB) connection.

For long distances and to reduce electrical noise, a lower baud rate, such as 19200, is recommended. See TT-1625 for more details.

Use SiteTech™ software to select that either the generator set controller or the transfer switch activates the EPS Supplying Load LED.

See the subsection, Accessory Connections, for terminal identifications.



Figure 141 Remote Serial Annunciator (RSA III)

Wiring

- For communication between the controller and RSA III master, see the figure below, P27 Connector on Master RSA III.
- For communication between RSA III Master and RSA III Slave, see the figure below, P27 Connection on RSA III Slave.
- Refer to the generator set wiring diagram for the RSA connections to the controller.
- If five or more devices are connected, place a terminating resistor on the last RSA III slave in the daisy chain connection.

Note:

When using RS-485 communication cable, connect the “shield” wire at either end but not at both ends.

P27 RS-485 Connections (from Controller to Master)	
P27-1	(-) Black (from controller)
P27-2	(+) White (from controller)
P27-3	Shield (from controller)
P27-4	(-) Black (to slave or terminating resistor)
P27-5	(+) White (to slave or terminating resistor)
P27-6	Shield (to slave or open)
Note: When using RS-485 communication cable, connect the “shield” wire at either end but not at both ends.	

Figure 142 P27 Connector on Master RSA III

Communication between RSA III Master and RSA III Slave. Select and connect the RS-485 wiring from the RSA III master to the RSA III slave(s) in a daisy chain wiring configuration. The figure below, “P27 Connection on RSA III Slave,” shows the master/slave RS-485 connections and “RSA III Circuit Board GM86125 Connectors” shows the RSA III with P27 location.

- For communication connections, use #12-24 AWG shielded, twisted-pair communication cable. For indoor, non-plenum installations, Belden #9841 or equivalent cable is recommended.
- For outdoor or plenum installations, including those with buried cables and/or conduit, use outdoor-rated cable, Belden 3105DB or 3106DN or equivalent.

All wiring must comply with applicable national and local codes.

P27 RS-485 Connections (from Master to Slave)	
P27-1	(-) Black (from master or previous slave)
P27-2	(+) White (from master or previous slave)
P27-3	Shield (from master or previous slave)
P27-4	(-) Black (to next slave or terminating resistor)
P27-5	(+) White (to next slave or terminating resistor)
P27-6	Shield (to next slave or open)
Note: When using RS-485 communication cable, connect the “shield” wire at either end but not at both ends.	

Figure 143 P27 Connection on RSA III Slave

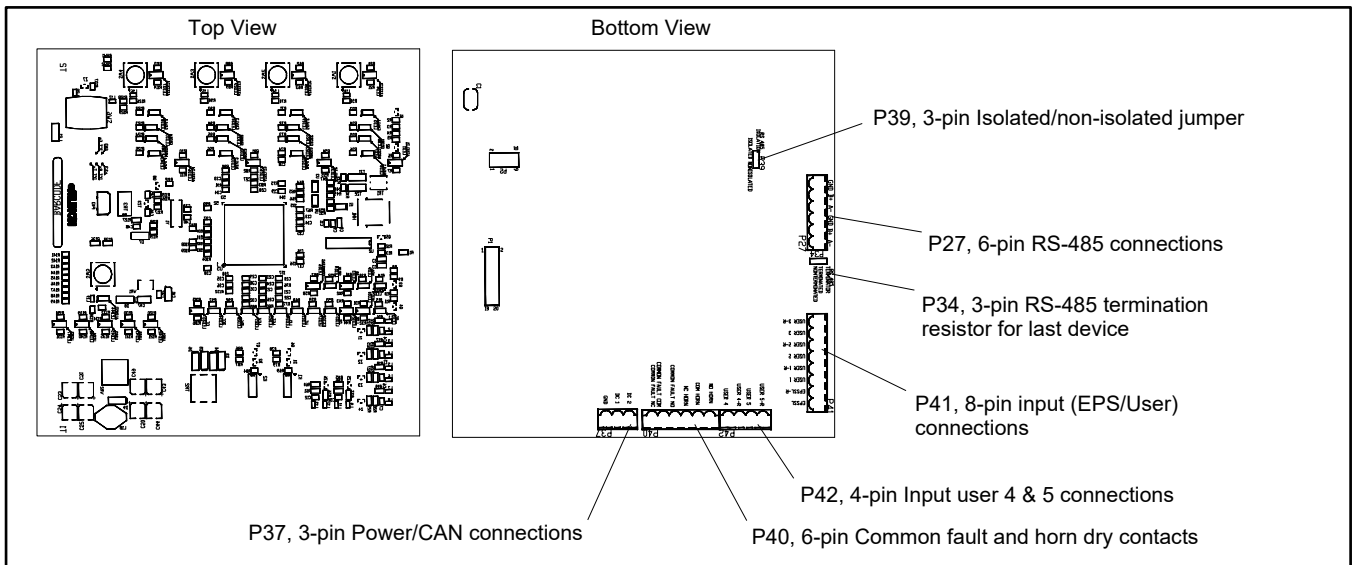

Figure 144 RSA III Circuit Board GM86125 Connectors

9.2.11 Shunt-Trip Line Circuit Breaker

A shunt-trip line circuit breaker provides a 12- or 24-DC volt solenoid within the line circuit breaker case that can energize the trip mechanism. This feature allows the circuit breaker to be tripped by the common fault. Connection requires a shunt-trip wiring kit, which includes a shunt trip wiring harness and a dry contact kit.

The relay has contacts rated at 10 amps at 28 VDC or 120 VAC and is used to trigger the shunt-trip line circuit breaker kit.

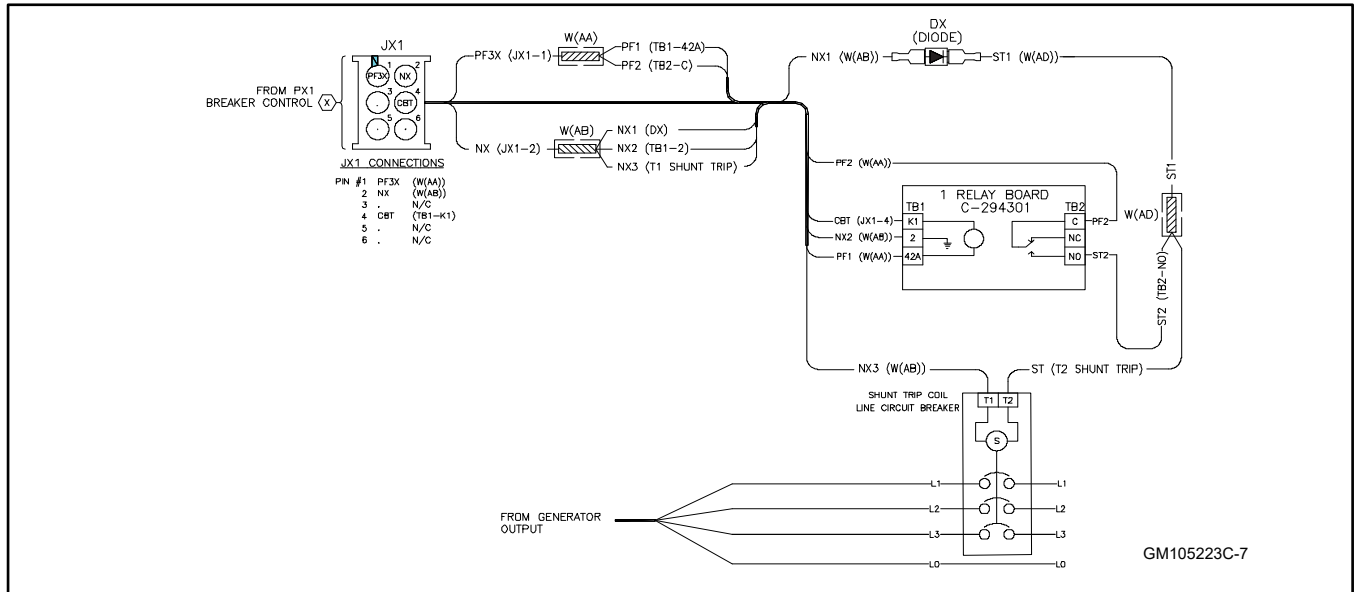

Figure 145 Shunt-Trip Wiring (80–500 kW generator sets)

9.2.12 Power Distribution Switchboards

Power Distribution Switchboards

Power distribution switchboards (PDS) for paralleling systems are available. Refer to the PDS specification sheet for switchboard and circuit breaker information. The installation manual provided with the switchboards contains instructions for switchboard installation and maintenance.

9.3 Accessory Connections

9.3.1 Controller Connections

Controller Connections

All customer connections to the controller are made to terminal strips or quick-connect terminals. Do not attempt to connect customer equipment directly to the controller.

Connectors inside the controller box provide connections for optional accessories. See Figure 146.

Terminal block TB12 provides customer connection points for emergency stop, remote start/stop, Modbus devices including the RSA III, and standard inputs and outputs. See Figure 147.

Note:

Do not apply voltage to dry contact inputs. Provide proper circuit protection to relay connections.

For specific information on accessory connections, refer to the accessory wiring diagrams in the wiring diagram manual and the instruction sheet accompanying the kit.

Control Box Connectors		
Terminal	Description	
Ethernet module RJ45 connector	Ethernet	
Quick-Connects		
QCON5	63C	Fuel level sender
QCON6	N17	
QCON7	64	Fuel leak alarm
QCON8	N18	
Connecting Plugs		
PB1	Bus voltage sense	
PR1	Common fault relay	
PR2	Factory only	
PR3	Factory only	
P15	4-in/15-out module	
P23	Crank relay	
P24	Run relay	
P30	Breaker close	
P31	Breaker open	
PK1	Manual key switch	
PX1	Breaker control	
TX1	Remote EOB	
TX5	Remote breaker bus sense	

Figure 146 Control Box Connectors

TB12 Terminal Strip			
Position	Description		
TB12-1	Emergency stop	Remove jumper if using E-stop	Use dry contact
TB12-2			
TB12-3	Remote start	Use dry contact	Use dry contact
TB12-4			
TB12-5	Fused battery power		10 A fused @ 24VDC Nominal
TB12-6	Battery positive during crank and run		10 A fused @ 24VDC Nominal
TB12-7	Battery negative		0 VDC
TB12-8	PGEN Isolated RS-485 #2	A (-)	For paralleling generators
TB12-9		B (+)	
TB12-10		Shield	
TB12-11	Low fuel level switch	Signal	Use dry contact
TB12-12		Return	Diesel models only No connection for gas models
TB12-13	Battery charger fault	Signal	Use dry contact
TB12-14		Return	
TB12-15	Auxiliary warning	Signal	Use dry contact
TB12-16		Return	
TB12-17	Auxiliary fault	Signal	Use dry contact
TB12-18		Return	
TB12-19	Modbus Isolated RS-485 #3	A (-)	For Modbus RTU, RS485
TB12-20		B (+)	
TB12-21		Shield	
TB12-22	RSA Non-isolated RS-485 #4	A (-)	For Modbus RTU, RS485
TB12-23		B (+)	
TB12-24		Shield	
TB12-25	Run relay dry contacts	Common	10A @28 VDC max.
TB12-26		NO	10 A @120 VAC max.
TB12-27		NC	6.66 A @ 250 VAC max
TB12-28	Speed bias	(+) Signal	+30 VDC/- 15 VDC Requires controller range setup
TB12-29		(-) Signal	
TB12-30		Shield	
TB12-31	Voltage bias	(+) Signal	+30 VDC/- 15 VDC Requires controller range setup
TB12-32		(-) Signal	
TB12-33		Shield	
TB12-34	Dual Fuel Natural Gas Contacts		Use dry contact
TB12-35			Gas models only No connection for diesel models
TB12-36	Isochronous Governor	JP2 Installed	Diesel models only No connection for gas models
	Droop Governor	JP2 Removed	
TB12-37	Analog Throttle Control	+5 VDC (ref)	Diesel models only
TB12-38		Signal (+2.5VDC Norm)	No connection for gas models
TB12-39		Sensor Return	Remove resistors if paralleling
TB12-40	Idle Mode	Consult Factory	Diesel models only
TB12-41			No connection for gas models
TB12-42	No Connection		
TB12-43	No Connection		
TB12-44	No Connection		

Figure 147 Terminal Strip TB12 Customer Connections (80–500 kW Models)

9.3.2 Four-Input/Fifteen-Output Module

Four Input/Fifteen Output Module

The optional four input/ fifteen output module provides additional inputs and outputs.

4 Input/15 Output Module Connections		
Terminal	Description	
P35 Connector		
P35	Controller Connection	
P36 Connector		
Differential (± 3 V) Analog Input Connections		
Terminal	Description	
P36-GND	AGND Analog Reference	
P36-VN1	ACH1 Negative Differential Signal	
P36-VP1	ACH1 Positive Differential Signal	
P36-+5V	Supply (50 mA max.)	
P36-GND	AGND Analog Reference	
P36-VN2	ACH2 Negative Differential Signal	
P36-VP2	ACH2 Positive Differential Signal	
P36-GND	Supply (50 mA max.)	
TB5 Terminal Block		
K15 Relay Output, 5 VDC, 2A		
TB5-C	Common	Common fault relay K15 output
TB5-NO	Normally open	Common fault relay K15 output
All other TB5 connections	Factory only	
TB6 Terminal Block		
DI1 - DI4 Digital Inputs		
TB6-DI1	Digital Input 1	
TB6-DI2	Digital Input 2	
TB6-DI3	Digital Input 3	
TB6-DI4	Digital Input 4	

TB7 Terminal Block		
K1 - K14 Relay Outputs, 10 A, 12VDC		
TB7 K1-NO	Normally open	K1 relay output
TB7 K1-C	Common	
TB7 K1-NC	Normally closed	
TB7 K2-NO	Normally open	K2 relay output
TB7 K2-C	Common	
TB7 K2-NC	Normally closed	
TB8 K3-NO	Normally open	K3 relay output
TB8 K3-C	Common	
TB8 K3-NC	Normally closed	
TB8 K4-NO	Normally open	K4 relay output
TB8 K4-C	Common	
TB8 K4-NC	Normally closed	
TB9 K5-NO	Normally open	K5 relay output
TB9 K5-C	Common	
TB9 K5-NC	Normally closed	
TB9 K6-NO	Normally open	K6 relay output
TB9 K6-C	Common	
TB9 K6-NC	Normally closed	
TB10 K7-NO	Normally open	K7 relay output
TB10 K7-C	Common	
TB10 K7-NC	Normally closed	
TB10 K8-NO	Normally open	K8 relay output
TB10 K8-C	Common	
TB10 K8-NC	Normally closed	
TB11 K9-NO	Normally open	K9 relay output
TB11 K9-C	Common	
TB11 K9-NC	Normally closed	
TB11 K10-NO	Normally open	K10 relay output
TB11 K10-C	Common	
TB11 K10-NC	Normally closed	
TB12 K11-NO	Normally open	K11 relay output
TB12 K11-C	Common	
TB12 K11-NC	Normally closed	
TB12 K12-NO	Normally open	K12 relay output
TB12 K12-C	Common	
TB12 K12-NC	Normally closed	
TB13 K13-NO	Normally open	K13 relay output
TB13 K13-C	Common	
TB13 K13-NC	Normally closed	
TB13 K14-NO	Normally open	K14 relay output
TB13 K14-C	Common	
TB13 K14-NC	Normally closed	

Figure 148 Input/Output Module Connections

Section 10. Decision-Maker 550 Controller Accessories

10.1 Accessories and Connections

Several accessories help finalize installation, add convenience to operation and service, and establish state and local code compliance.

Accessories vary with each generator set model and controller. Select factory-installed and/or shipped-loose accessories. See the figure below, Optional Accessories, for a list of available kits. Obtain the most current accessory information from your local authorized service distributor/dealer.

This section illustrates several accessories available at print time of this publication. Accessory kits generally include installation instructions. See wiring diagrams manual for electrical connections not shown in this section. See the installation instructions and drawings supplied with kit for information on kit mounting location.

The instructions provided with the accessory kit supersede these instructions where there are differences. In general, run AC and DC wiring in separate conduit. Use shielded cable for all analog inputs. Observe all applicable national, state, and local electrical codes during accessory installation.

Kit Description
Audiovisual Alarm
Common Failure Relay (Terminal 32A)
Controller (Customer) Connection
Float/Equalize Battery Charger (with alarms)
Ground Fault Annunciation
Idle (Speed) Mode Feature
Low Fuel (Level) Switch
Low Fuel (Pressure) Switch
Prime Power Switch
Remote Emergency Stop
Remote Reset Feature
Remote Serial Annunciator (RSA III)
Shunt-Trip Line Circuit Breaker and Shunt-Trip Wiring
Single-Relay Dry Contact
Ten-Relay Dry Contact
Twenty-Relay Dry Contact

Figure 149 Optional Accessories

10.1.1 Audiovisual Alarm Kit

An audiovisual alarm warns the operator at a remote location of fault shutdowns and prealarm conditions. Audiovisual alarms include an alarm horn, an alarm silence switch, and common fault lamp. See the figures below for connections. See the following subsection, "Accessory Connections," for terminal identification.

Note:

Use the audiovisual alarm with a dry contact kit

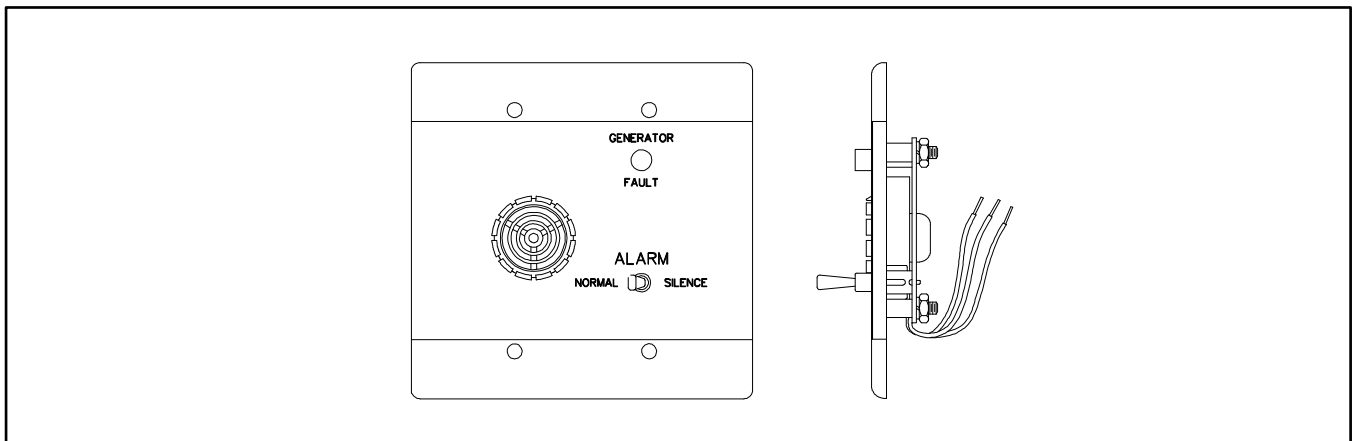

Figure 150 Audiovisual Alarm

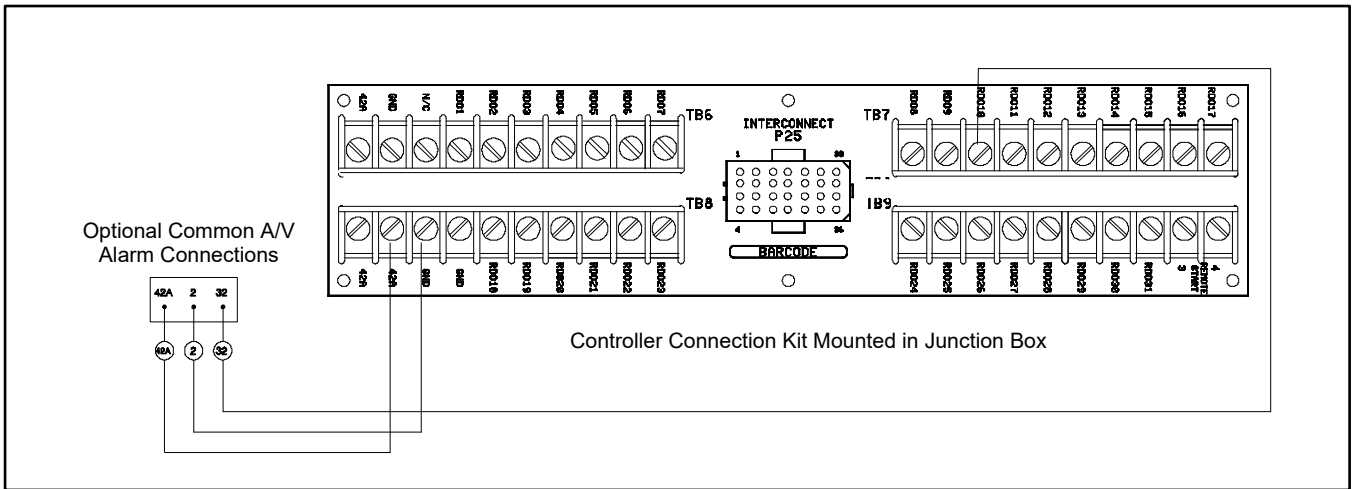

Figure 151 Audiovisual Alarm Connections

10.1.2 Common Failure Relay Kit

The common failure relay kit provides one set of contacts to trigger user-provided warning devices if a fault occurs. The common failure relay faults are user-defined. See the respective operation manual for status and faults available for this function.

Connect up to three common failure relay kits to the controller output. See the figures below for connections. See the following subsection on "Accessory Connections" for terminal identification.

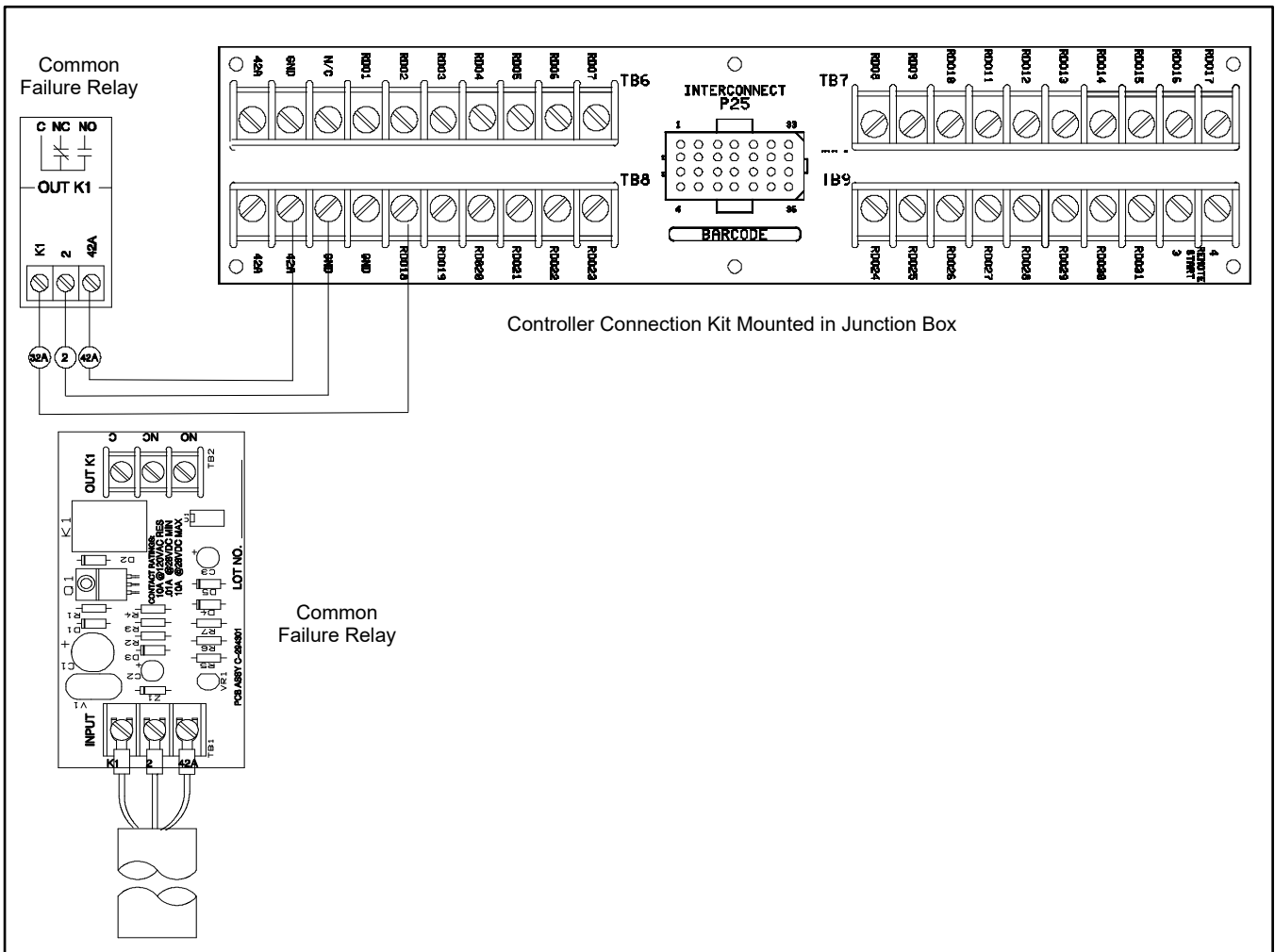

Figure 152 Common Failure Relay Kit Connections

10.1.3 Controller (Customer) Connection Kit

The controller connection kit allows easy connection of controller accessories without accessing the controller terminal strip. The supplied wiring harness connects controller connector P23 and terminal strips TB1-3 and TB1-4 to the controller connection kit connector P25 and terminal strips TB6, TB7, TB8, and TB9. Connect all accessories (except the emergency stop kit) to the controller connection kit terminal strips. See the figure below. See the following section, "Accessory Connections," for terminal identification.

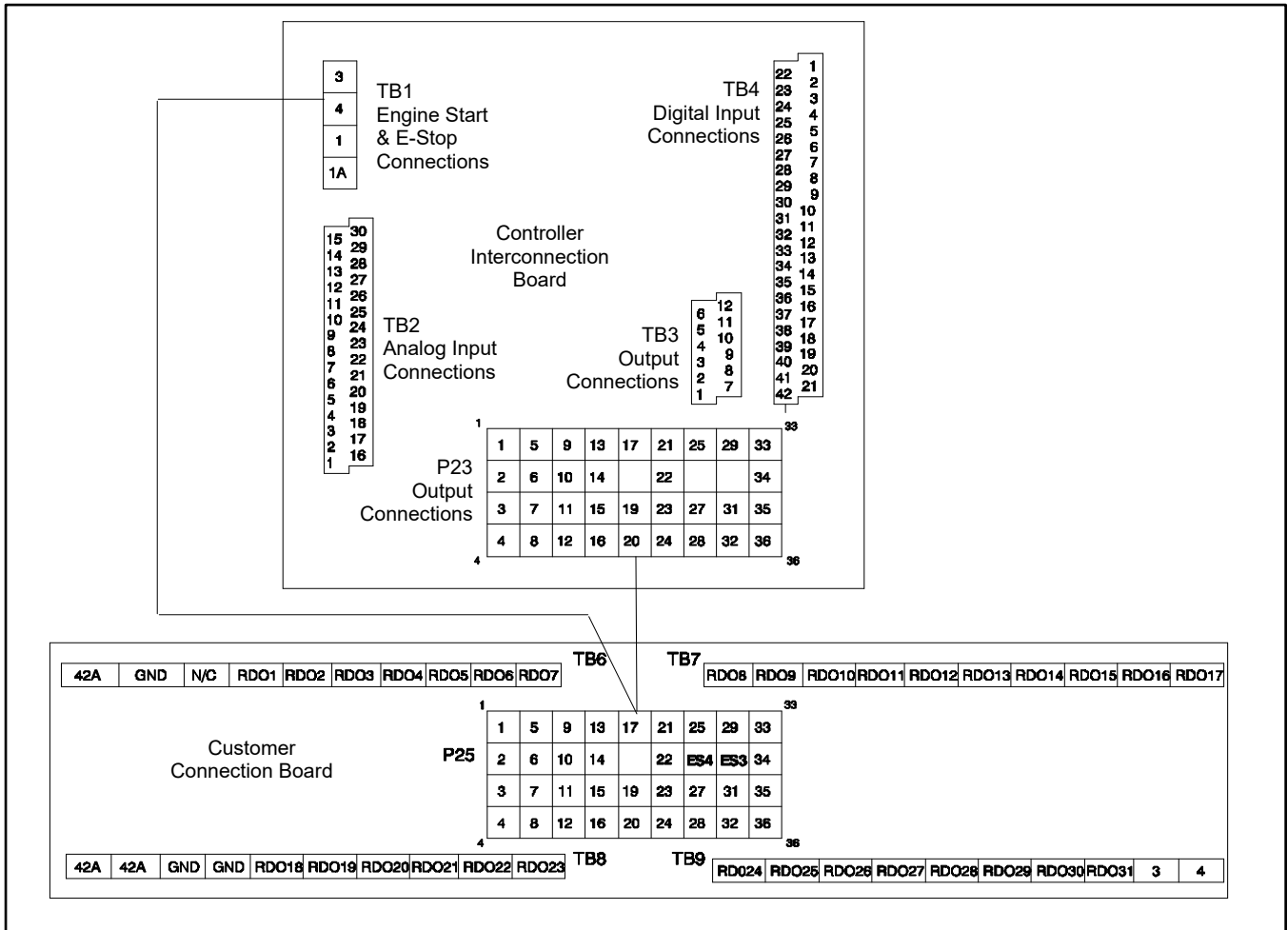

Figure 153 Controller (Customer) Connection Kit

10.1.4 Float/Equalize Battery Charger Kit with Alarm Option

The float/equalize battery charger with alarm option provides battery charging to the engine starting battery(ies) and connects to the controller for fault detection. Battery chargers for 12- or 24-volt models are available as a generator set accessory. See the figure below for connection details. See the following subsection, "Accessory Connections," for terminal identification.

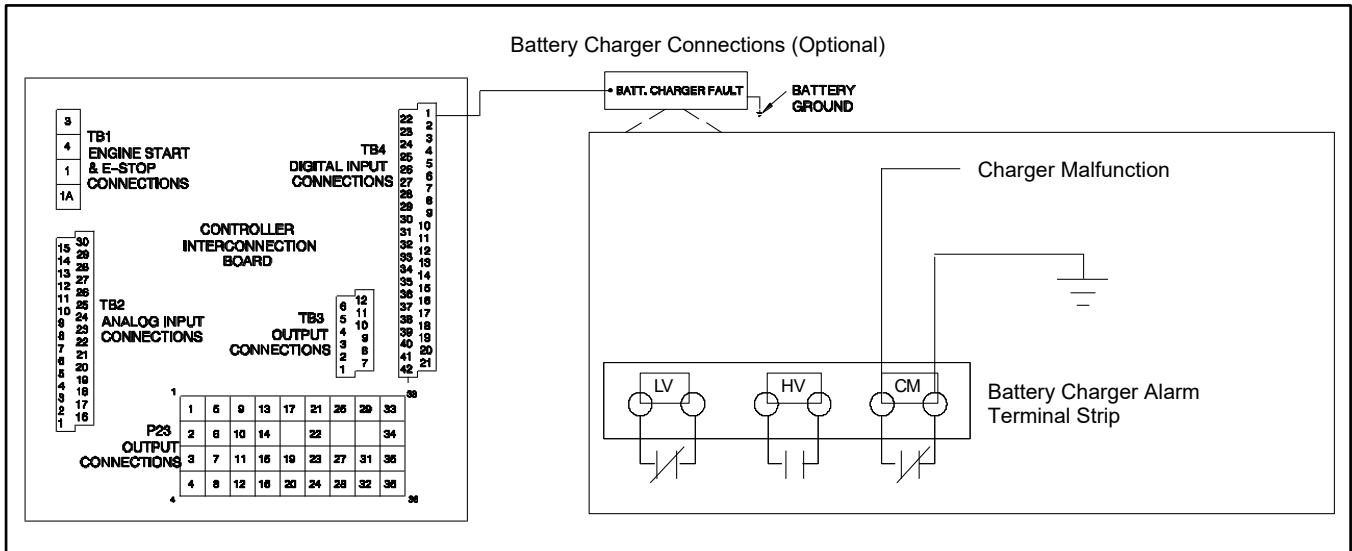



Figure 154 Float/Equalize Battery Charger Connections

10.1.5 Ground Fault Annunciation

 WARNING	<p>Accidental starting. Can cause severe injury or death.</p> <p>Disconnect the battery cables before working on the generator set. Remove the negative (-) lead first when disconnecting the battery. Reconnect the negative (-) lead last when reconnecting the battery.</p>
	

Disabling the generator set. Accidental starting can cause severe injury or death. Before working on the generator set or equipment connected to the set, disable the generator set as follows: (1) Move the generator set master switch to the OFF position. (2) Disconnect the power to the battery charger. (3) Remove the battery cables, negative (-) lead first. Reconnect the negative (-) lead last when reconnecting the battery. Follow these precautions to prevent starting of the generator set by an automatic transfer switch, remote start/stop switch, or engine start command from a remote computer.

A relay contact for customer connection indicates a ground fault condition and is part of a ground fault alarm. See the figure below for electrical connections and the steps in the following procedure for controller setup. Use the instructions with the kit when provided to install and setup this accessory.

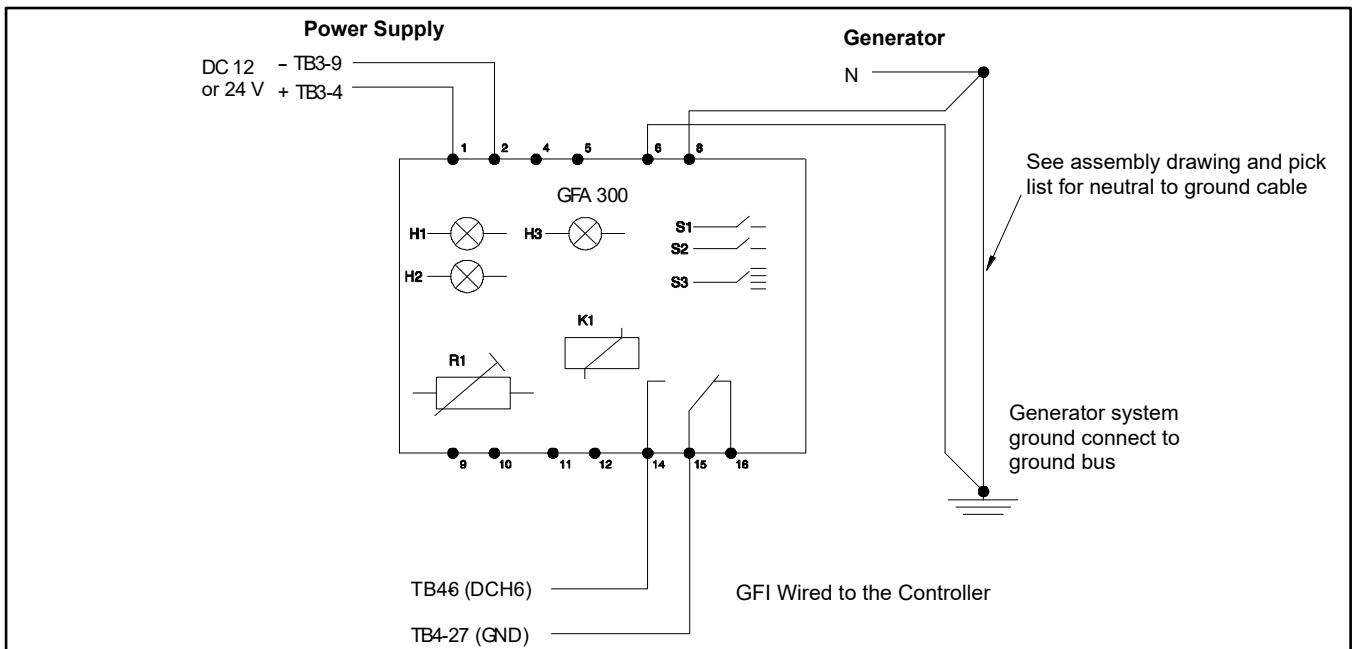

Figure 155 Ground Fault Connections



Ground Fault Controller Setup Procedure

1. Reconnect battery, if not already done.
2. Place the controller master switch to the AUTO position.
3. Press the Alarm Off key to silence the alarm horn, if necessary.
4. If the programming mode LED is not flashing, go to the step 5. If the programming mode LED is flashing, go to step 6.
5. Set Programming Mode to Local.



a. Press keys     

b. Press key  until Programming Mode- Local is displayed.

c. Press the YES   key.











d. When the Enter Code displays, press the factory default   or the user password keys and . The programming mode LED should be flashing.

6. Set digital input #6 to ground fault.

a. Press    Menu 9 Input Setup should be displayed.

b. Press  until Digital Input 06 warning is displayed.











c. Press  once to select this input.

- d. Press  until Ground Fault is displayed.
- e. Press   to define Digital Input #06 as ground fault. Entry Accepted is displayed.
- f. Press  to display Digital Input #06 Inhibit Time.
- g. Press   to enter the inhibit time. Entry Accepted is displayed and the inhibit time 0:00 is now displayed.
- h. Press  display Digital Input #006 Delay Time.
- i. Press   enter delay time. Entry Accepted is displayed. Default delay time is 5 sec.
- j. Press .

7. Verify Programming.

- a. Move handle of ground fault circuit breaker at generator set to simulate a ground fault.
- b. Verify that display shows D06 Ground Fault. The System Warning LED should be illuminated and the alarm horn should sound. If these indicators are not present, recheck steps 6a. through 6j.
- c. Return handle of ground fault circuit breaker to the non-ground fault position. D06 Ground Fault display should now be cleared.

8. Set Programming Mode to Off.

- a. Press    .
- b. Press key  until Programming Mode Off is displayed.
- c. Press the YES key  .
- d. When the Enter Code displays, press the factory default   or the user password keys and . The programming mode LED should now be off.

9. Place the controller master switch to the OFF/RESET position.
10. Disconnect the battery negative (-) lead to power down the generator set.
11. After 2–3 minutes, reconnect the battery negative (-) lead.
12. Reset the controller clock. See Menu 6 – Time and Date.

10.1.6 Idle (Speed) Mode Feature

The idle (speed) mode feature provides the ability to start and run the engine at idle (reduced) speed for a selectable time period (0-10 minutes) during warm-up. The controller will override the idle speed mode if the engine reaches the preprogrammed engine warmed-up temperature before the idle mode times out. See the figure below for user-supplied switch connection.

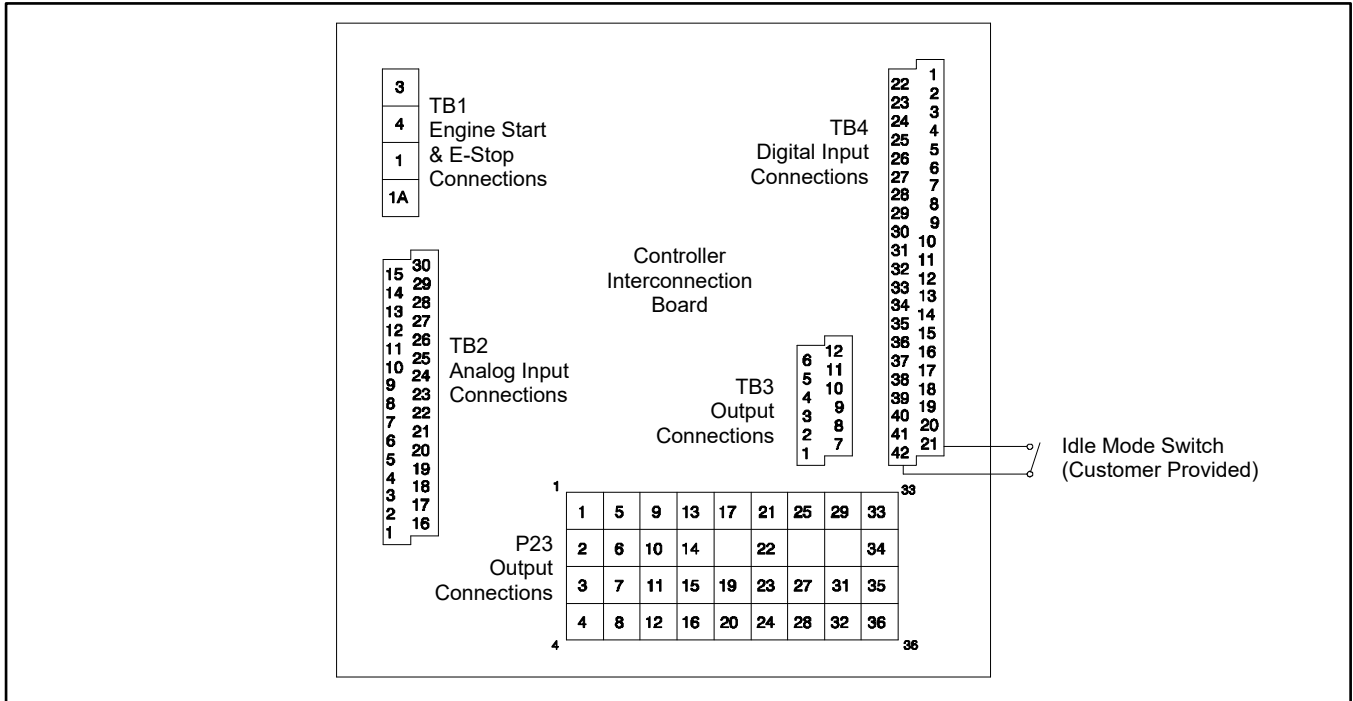

Figure 156 Idle (Speed) Mode Switch

10.1.7 Low Fuel (Level/Pressure) Switch

Some gaseous-fueled models offer a low fuel pressure switch. The low fuel pressure switch connects to the gasoline-fueled models. See the figures below for connection details. See the following subsection, "Accessory Connections, for terminal identification.

Note:

The main tank or the transfer/day tank includes the low fuel level switch. The fuel tank supplier typically provides the low fuel level switch.

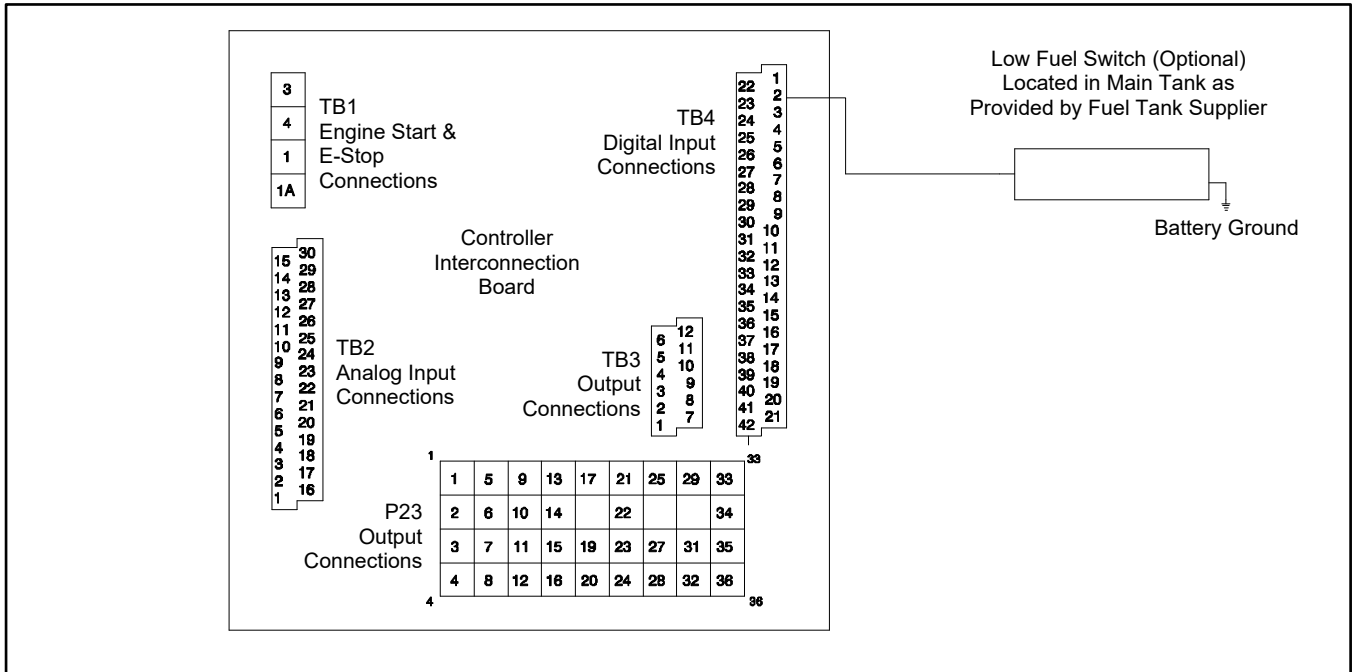

Figure 157 Low Fuel Switch (Level or Pressure)

Switch Rating	12 volts DC minimum, 0.5 amp minimum
Wiring Recommendation	
Gauge	mm (ft.)
18-20	30.5 (100)
14	153 (500)
10	305 (1000)

Figure 158 Switch Rating and Wiring Recommendations

10.1.8 Prime Power Switch Kit

The prime power switch kit prevents battery drain during generator set nonoperation periods and when the generator set battery cannot be maintained by an AC battery charger. See the figures below for an illustration of the kit and the electrical connections

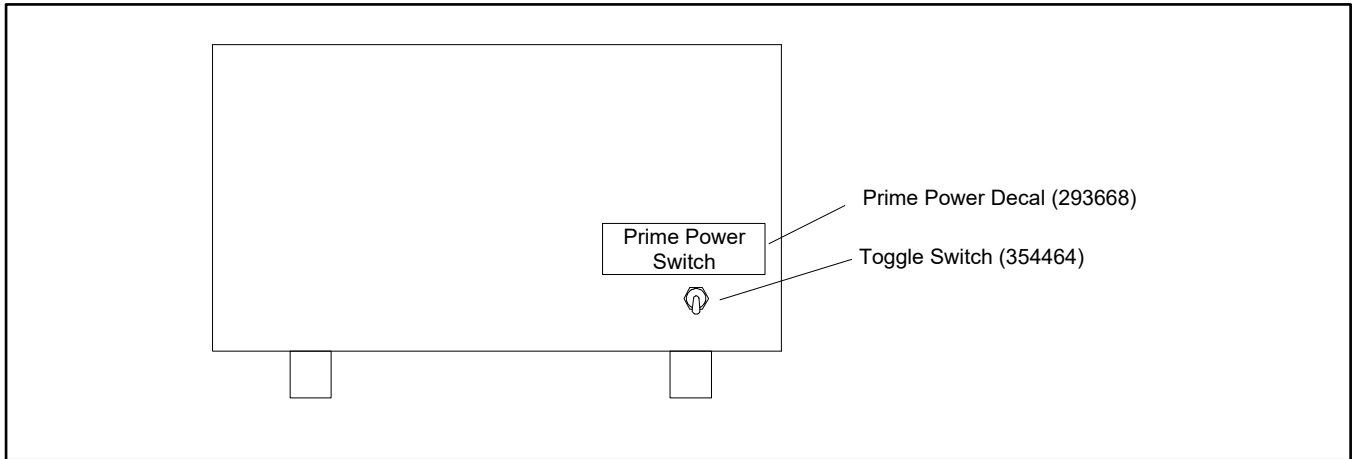

Figure 159 Prime Power Switch Installation Location

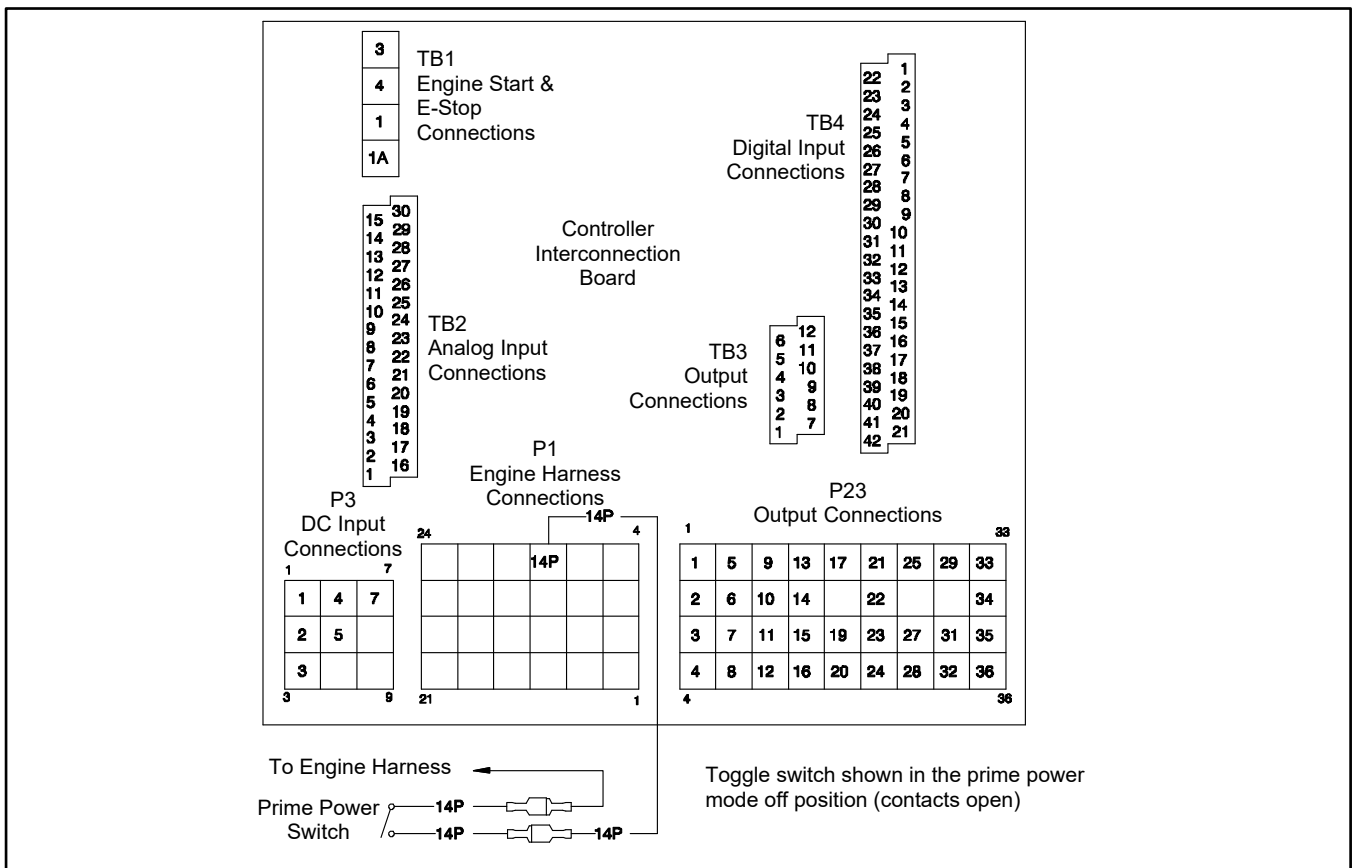

Figure 160 Prime Power Switch Connection

Stop the generator set using the stopping procedures in the respective operation manual before placing the generator set in the prime power mode. Move the prime power switch located on the back of the controller to the DOWN position. The controller including the digital display, LEDs, and alarm horn does not function when the generator set is in the prime power mode.

Move the prime power switch located on the back of the controller to the UP position and reset the controller time and date before attempting to start the generator set.

10.1.9 Remote Emergency Stop Kit

The emergency stop kit allows immediate shutdown of the generator set from a remote location. See the following figures for connection details. Install the emergency stop switch in a location that is easily accessible by operating personnel. Connect as many emergency stop switches as required; however, connect multiple switches in series so the system functions correctly.

Two emergency stop kits are available. See the image below.

- For the emergency stop switch, use the single glass piece located inside the switch for replacement and order additional glass pieces as service parts. See the respective operation manual for the Emergency Stop Switch Reset Procedure. See the following subsection, "Accessory Connections," for terminal identifications.
- The lockable emergency stop kit allows the installation of a lockout/tagout device to lock the switch in the STOP position. Insert a locking device through the openings in the shroud to prevent resetting the switch.

Refer to the instructions provided with the kit for installation instructions.

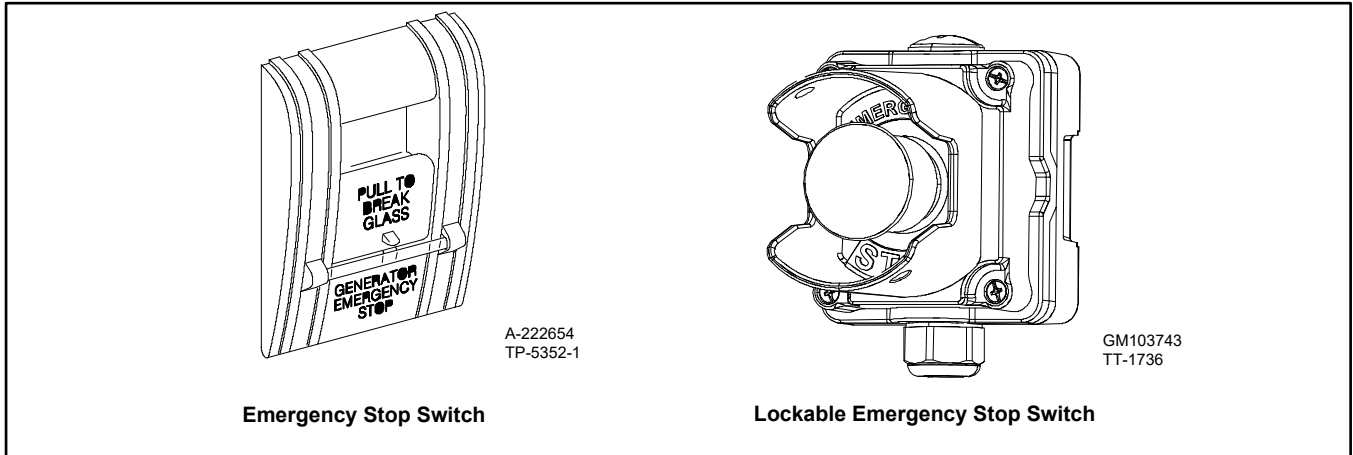

Figure 161 Emergency Stop Kits

See the figure below for typical connections. Refer to the generator set wiring diagram for your model.

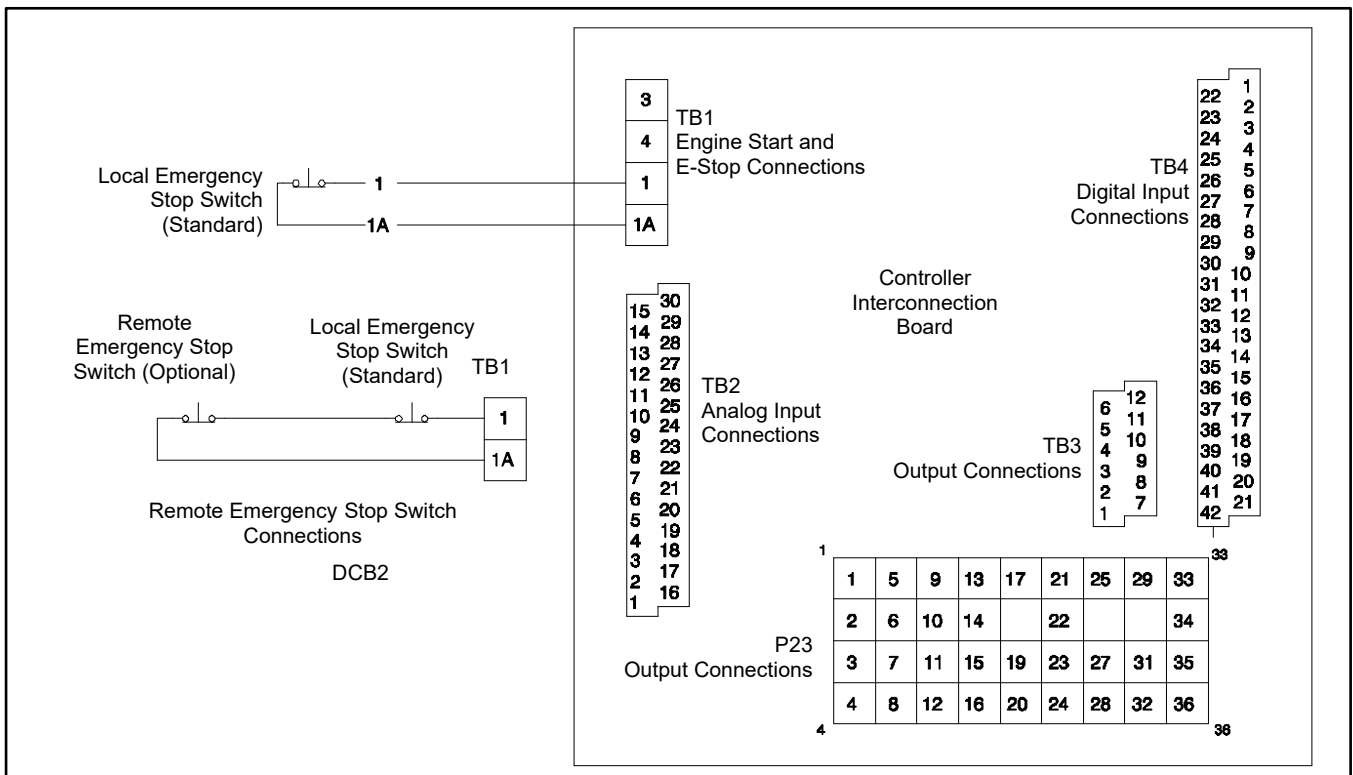

Figure 162 Remote Emergency Stop Kit Connections

10.1.10 Remote Reset Feature

The remote reset switch provides generator set resetting after a fault shutdown at a remote location. See the following figures for user-supplied switch connection.

Press and hold the switch for 2-3 seconds and release to reset the generator set controller.

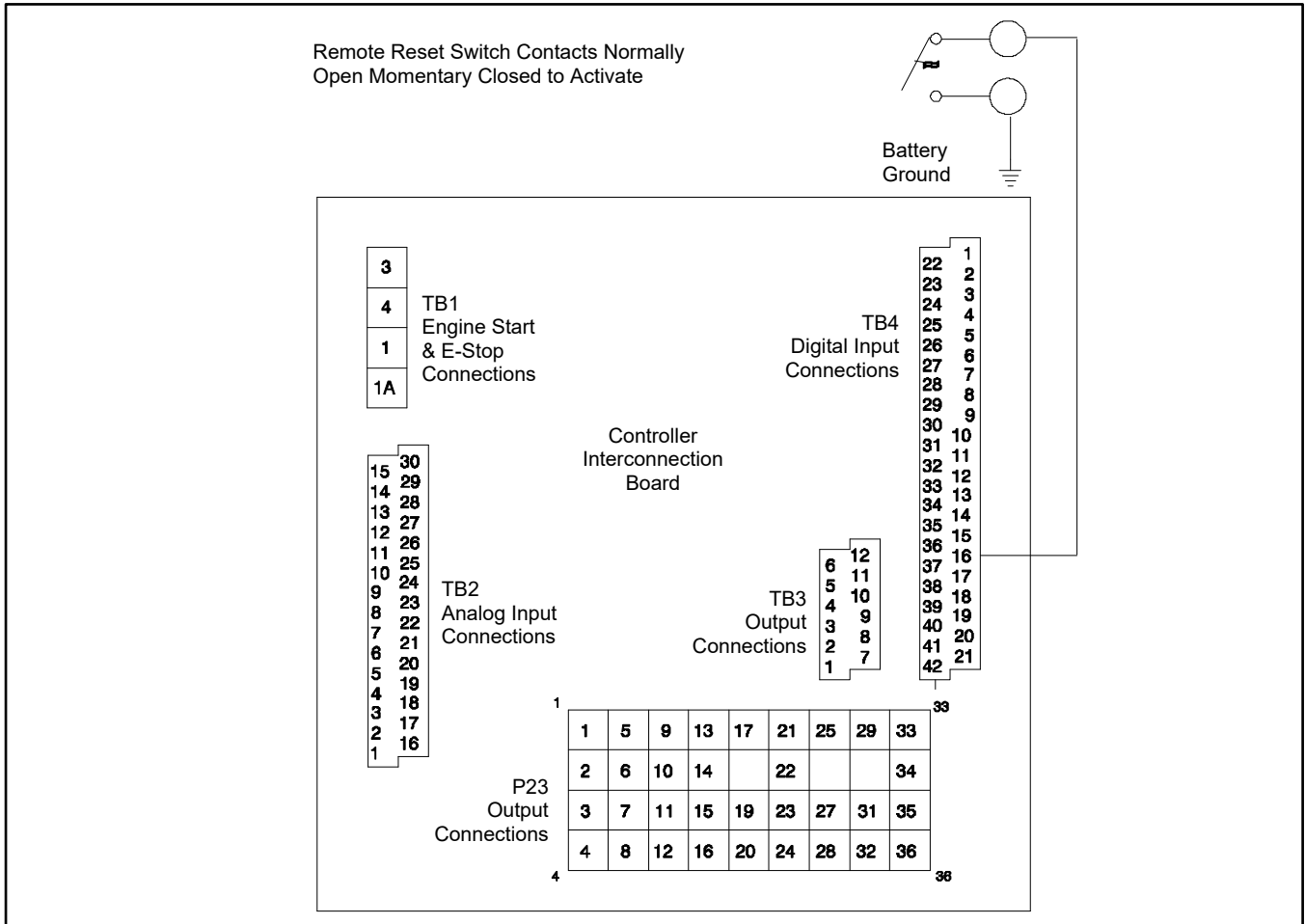

Figure 163 Remote Reset Switch Connections

Switch Rating	12 volts DC minimum, 0.5 amp minimum
Wiring Recommendation	
Gauge	Mm (ft.)
18-20	30.5 (100)
14	153 (500)
10	305 (1000)

Figure 164 Switch Rating & Wiring Recommendation

10.1.11 Remote Serial Annunciator (RSA III)

Refer to the RSA III installation instructions, TT-1625.

RSA III is an annunciator panel offered in several kit configurations to support power equipment. The RSA III is a remote serial annunciator that monitors the condition of the generator set and/or ATS from a remote location. The RSA III alerts the operator through visual and audible signals using LED indication and a horn. An alarm silence and lamp test switch are included.

The RSA III meets NFPA 110, Level 1 (2005) applications that require remote controls and alarms to be powered by a storage battery such as the engine starting battery. AC adaptor kit GM62466-KP1 is available when NFPA is not required.

A personal computer (PC) with SiteTech™ software is required to make the RSA III functional. SiteTech™ is available to authorized distributors and dealers.

An RSA III annunciator can be used for a single generator set or with a combination of a generator set and automatic transfer switch(es). In systems using more than a single RSA III, one must be designated as the master device to broadcast to additional RSA III annunciators, designated as slave devices. Up to five RSA III slave devices can be used with an RSA III master device. All RSA III annunciators are factory set as the master device, but can be changed to a slave device using a personal computer (PC) and SiteTech™ software that connects to the RSA III front panel via a universal serial bus (USB) connection.

For long distances and to reduce electrical noise, a lower baud rate, such as 19200, is recommended. See TT-1625 for more details.

Use SiteTech™ software to select that either the generator set controller or the transfer switch activates the EPS Supplying Load LED.

See the subsection, Accessory Connections, for terminal identifications.



Figure 165 Remote Serial Annunciator (RSA III)

Wiring

- For communication between the controller and RSA III master, see the figure below, P27 Connector on Master RSA III.
- For communication between RSA III Master and RSA III Slave, see the figure below, P27 Connection on RSA III Slave.
- Refer to the generator set wiring diagram for the RSA connections to the controller.
- If five or more devices are connected, place a terminating resistor on the last RSA III slave in the daisy chain connection.

Note:

When using RS-485 communication cable, connect the “shield” wire at either end but not at both ends.

P27 RS-485 Connections (from Controller to Master)	
P27-1	(-) Black (from controller)
P27-2	(+) White (from controller)
P27-3	Shield (from controller)
P27-4	(-) Black (to slave or terminating resistor)
P27-5	(+) White (to slave or terminating resistor)
P27-6	Shield (to slave or open)
Note: When using RS-485 communication cable, connect the "shield" wire at either end but not at both ends.	

Figure 166 P27 Connector on Master RSA III

Communication between RSA III Master and RSA III Slave. Select and connect the RS-485 wiring from the RSA III master to the RSA III slave(s) in a daisy chain wiring configuration. The figure below, "P27 Connection on RSA III Slave," shows the master/slave RS-485 connections and "RSA III Circuit Board GM86125 Connectors" shows the RSA III with P27 location.

- For communication connections, use #12-24 AWG shielded, twisted-pair communication cable. For indoor, non-plenum installations, Belden #9841 or equivalent cable is recommended.
- For outdoor or plenum installations, including those with buried cables and/or conduit, use outdoor-rated cable, Belden 3105DB or 3106DN or equivalent.

All wiring must comply with applicable national and local codes.

P27 RS-485 Connections (from Master to Slave)	
P27-1	(-) Black (from master or previous slave)
P27-2	(+) White (from master or previous slave)
P27-3	Shield (from master or previous slave)
P27-4	(-) Black (to next slave or terminating resistor)
P27-5	(+) White (to next slave or terminating resistor)
P27-6	Shield (to next slave or open)
Note: When using RS-485 communication cable, connect the "shield" wire at either end but not at both ends.	

Figure 167 P27 Connection on RSA III Slave

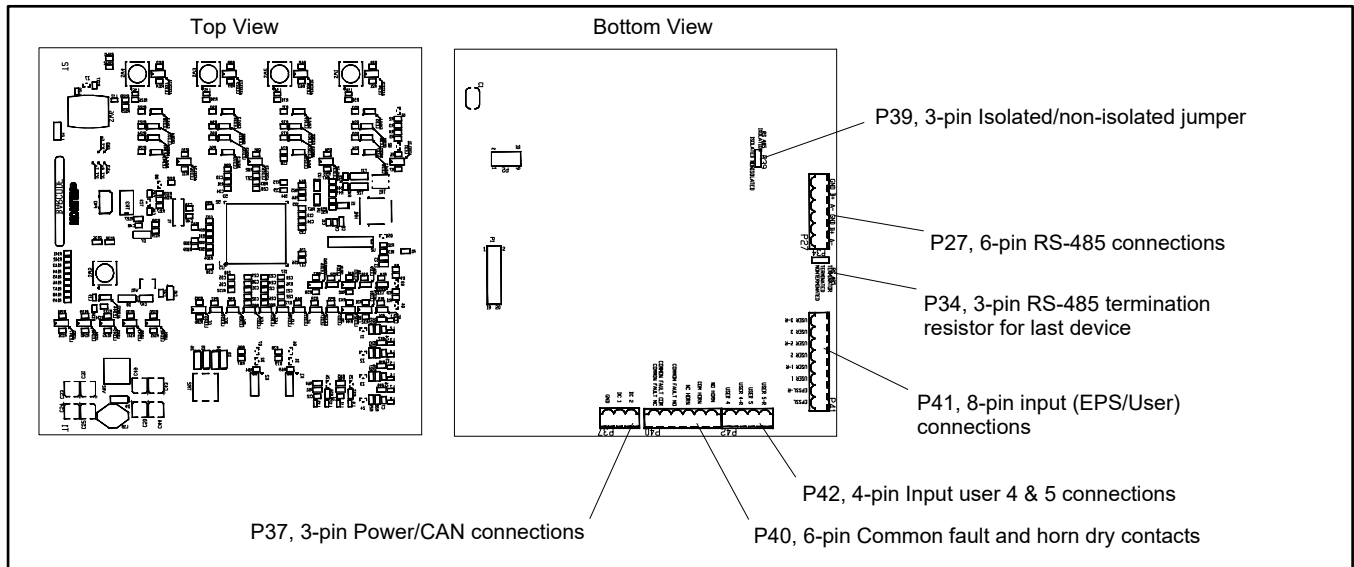

Figure 168 RSA III Circuit Board GM86125 Connectors

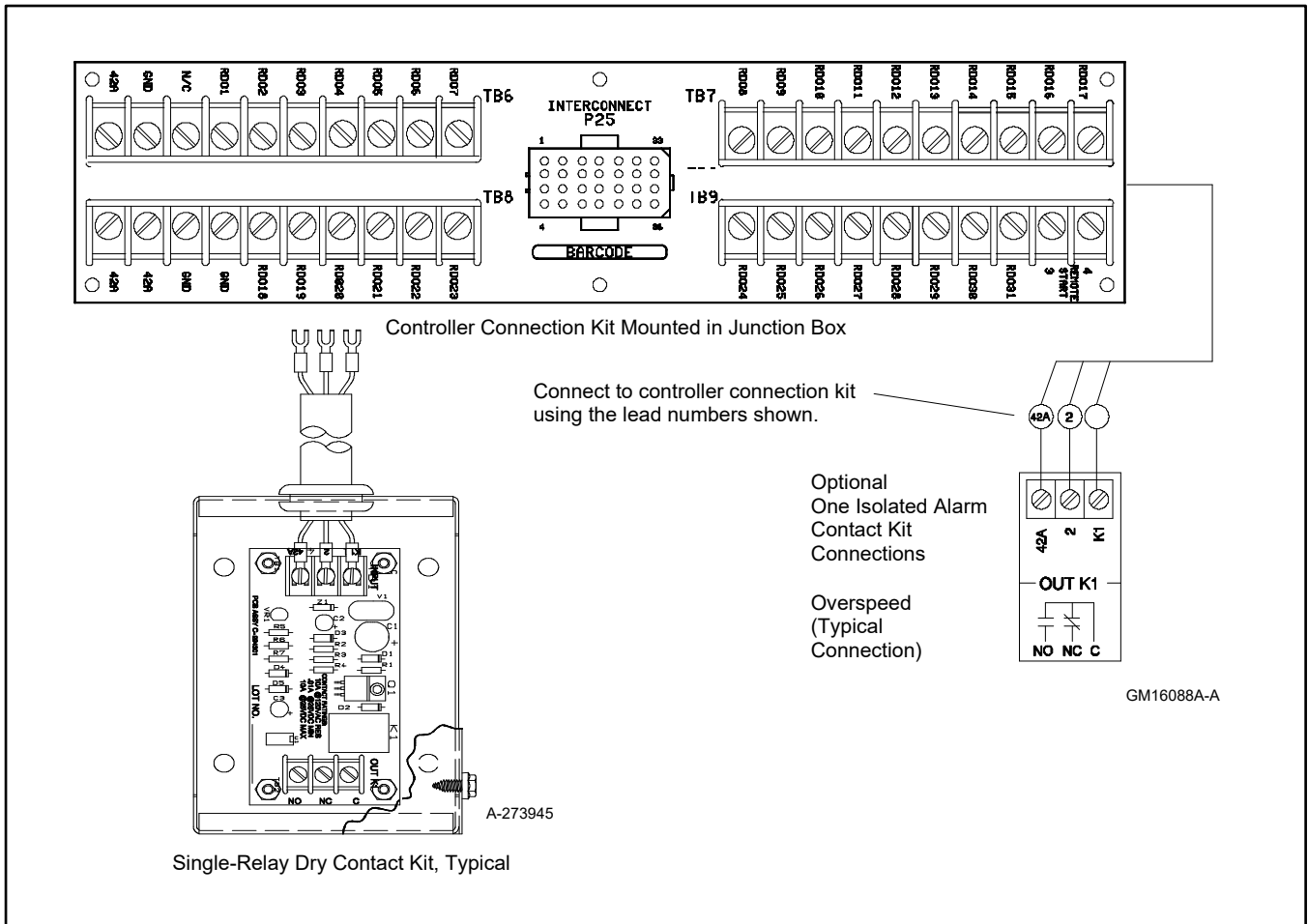

Figure 170 Single-Relay Dry Contact Kit Connections

10.1.14 Ten-Relay Dry Contact Kit

The ten-relay dry contact kit provides normally open and normally closed contacts in a form C configuration to activate warning devices and other user-provided accessories allowing remote monitoring of the generator set. Connect any controller fault output to the ten-relay dry contact kit. Typically, lamps, audible alarms, or other devices signal the fault conditions.

Refer to the figure, "Ten-Relay Dry Contact Kit" for an internal view of the contact kit. See the figure, "Ten-Relay Dry Contact Kit Connections," for electrical connections. See the following subsection, "Accessory Connections," for terminal identifications.

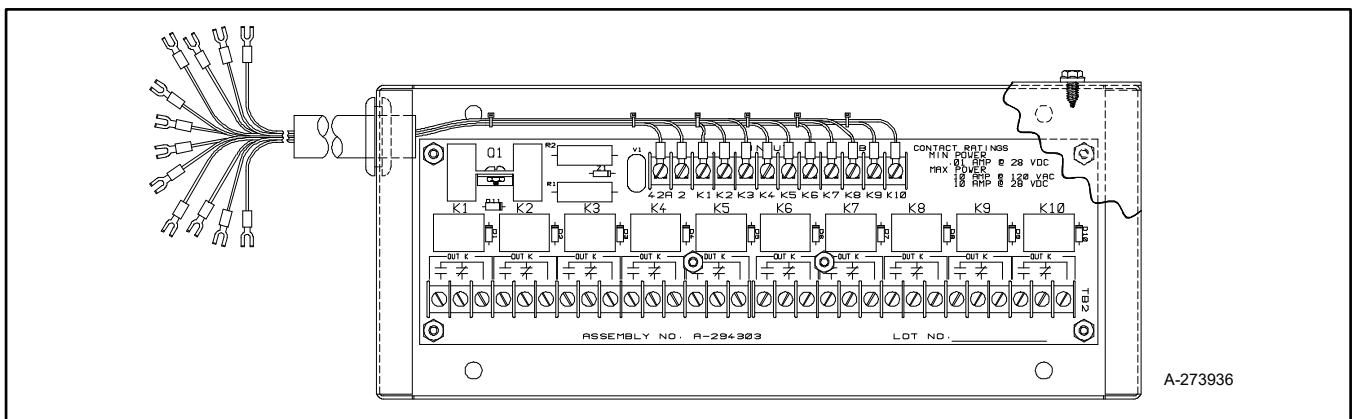

Figure 171 Ten-Relay Dry Contact Kit

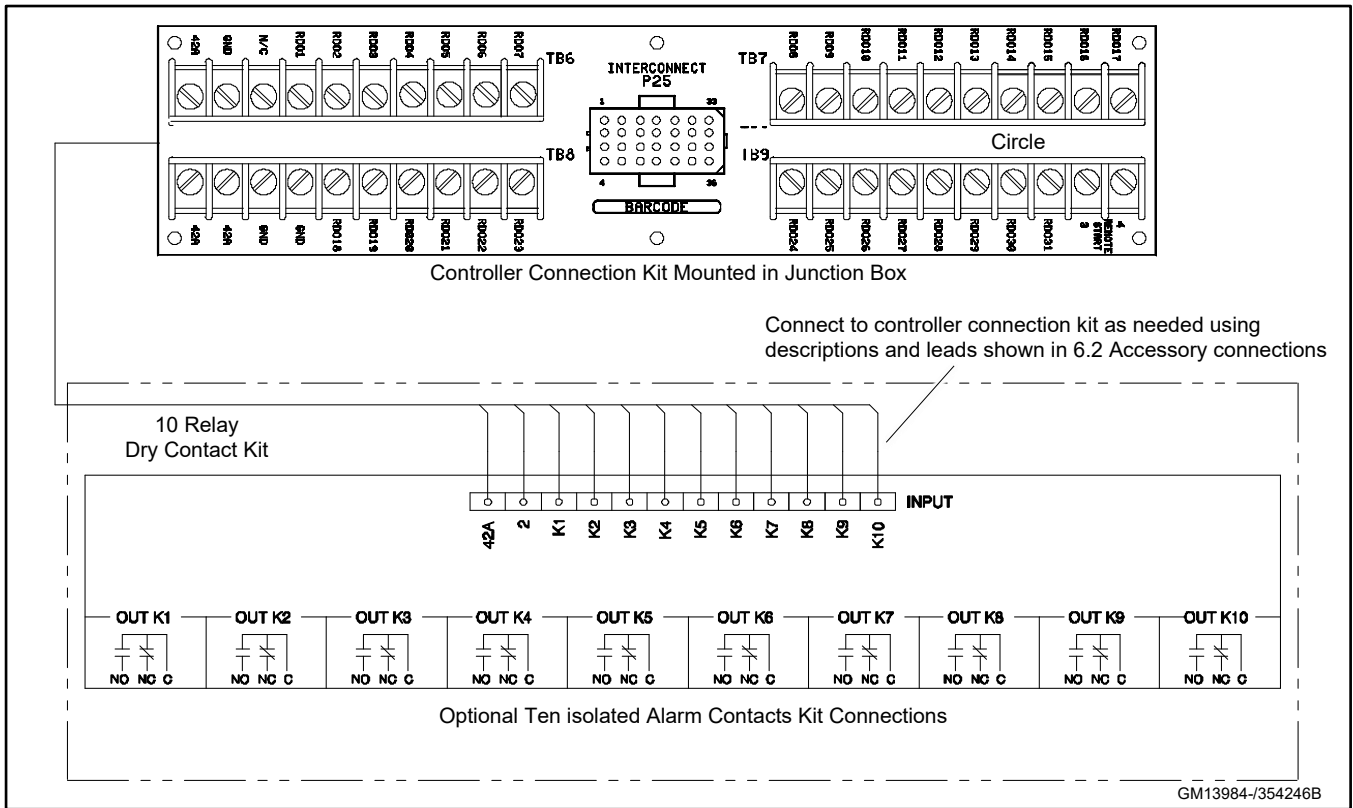

Figure 172 Ten-Relay Dry Contact Kit Connections

10.1.15 Twenty-Relay Dry Contact Kit

The twenty-relay dry contact kit provides normally open and normally closed contacts in a form C configuration to activate warning devices and other user-provided accessories allowing remote monitoring of the generator set. Typically, lamps, audible alarms, or other devices signal faults or status conditions. Connect any generator set fault output to the dry contact kit.

Refer to the figure below, “Twenty-Relay Dry Contact Kits” for an internal view of the contact kit. See the figure, “Twenty-Relay Dry Contact Relay Kit Connections” for electrical connections. See the following subsection, “Accessory Connections,” for terminal identifications.

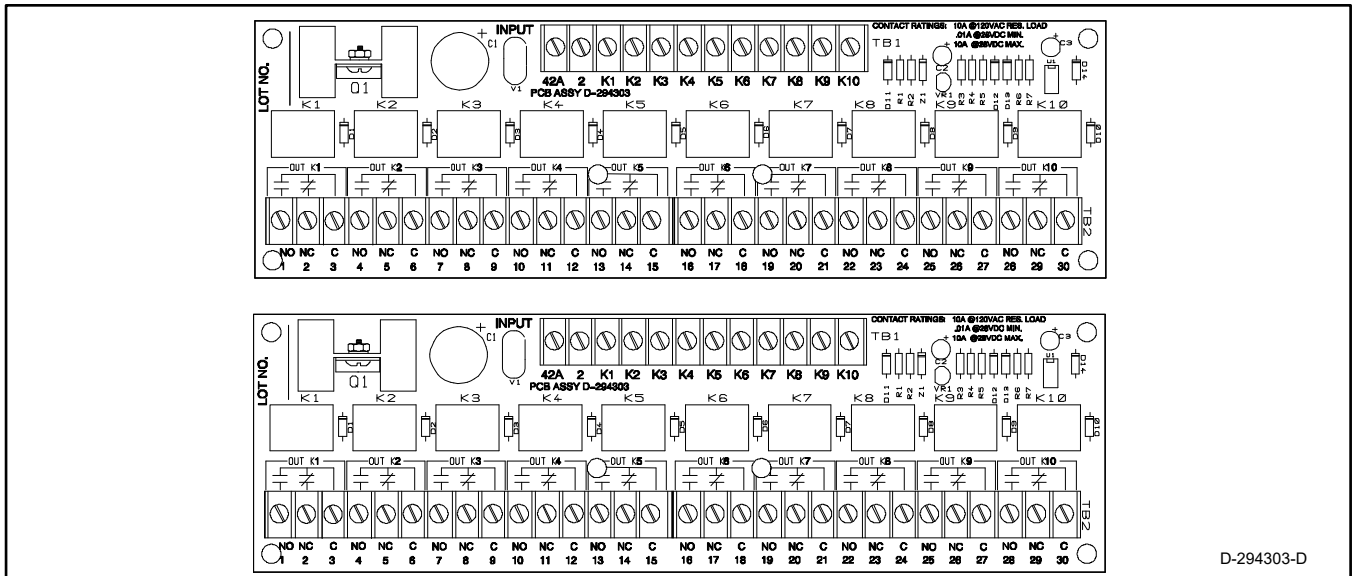

Figure 173 Twenty-Relay Dry Contact Kits

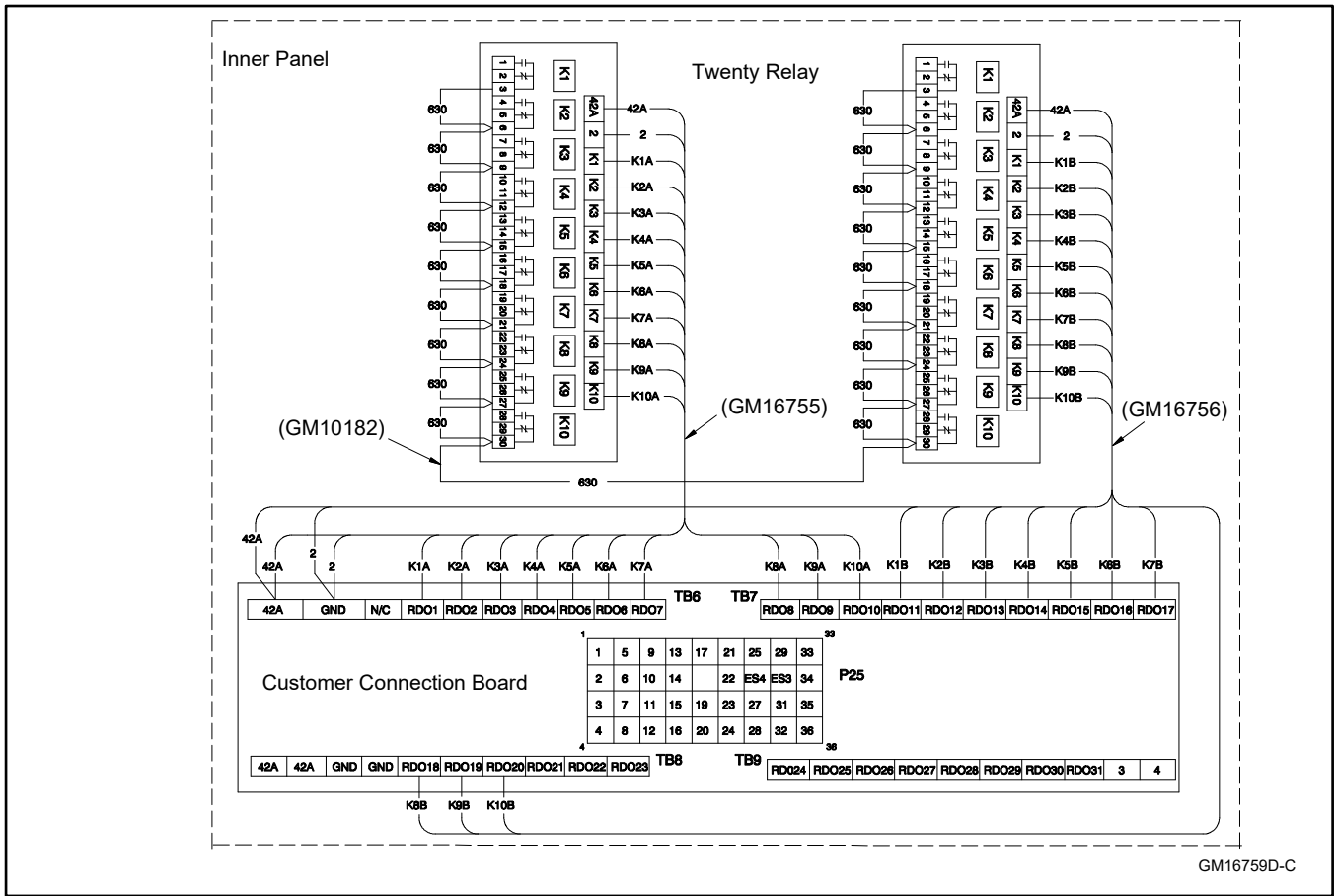

Figure 174 Twenty-Relay Dry Contact Relay Kit Connections

10.2 Accessory Connections

The controller contains circuit boards equipped with terminal strip(s) for use in connecting a controller connection kit. Do not connect accessories directly to the controller terminal strip(s). Connect accessories to either a controller connection kit or a dry contact kit. Connect the dry contact kit(s) to the controller connection kit. Connect alarms, battery chargers, remote switches, and other accessories to the dry contact kit relay(s).

For specific information on accessory connections, refer to the accessory wiring diagrams in the wiring diagram manual and the instruction sheet accompanying the kit.

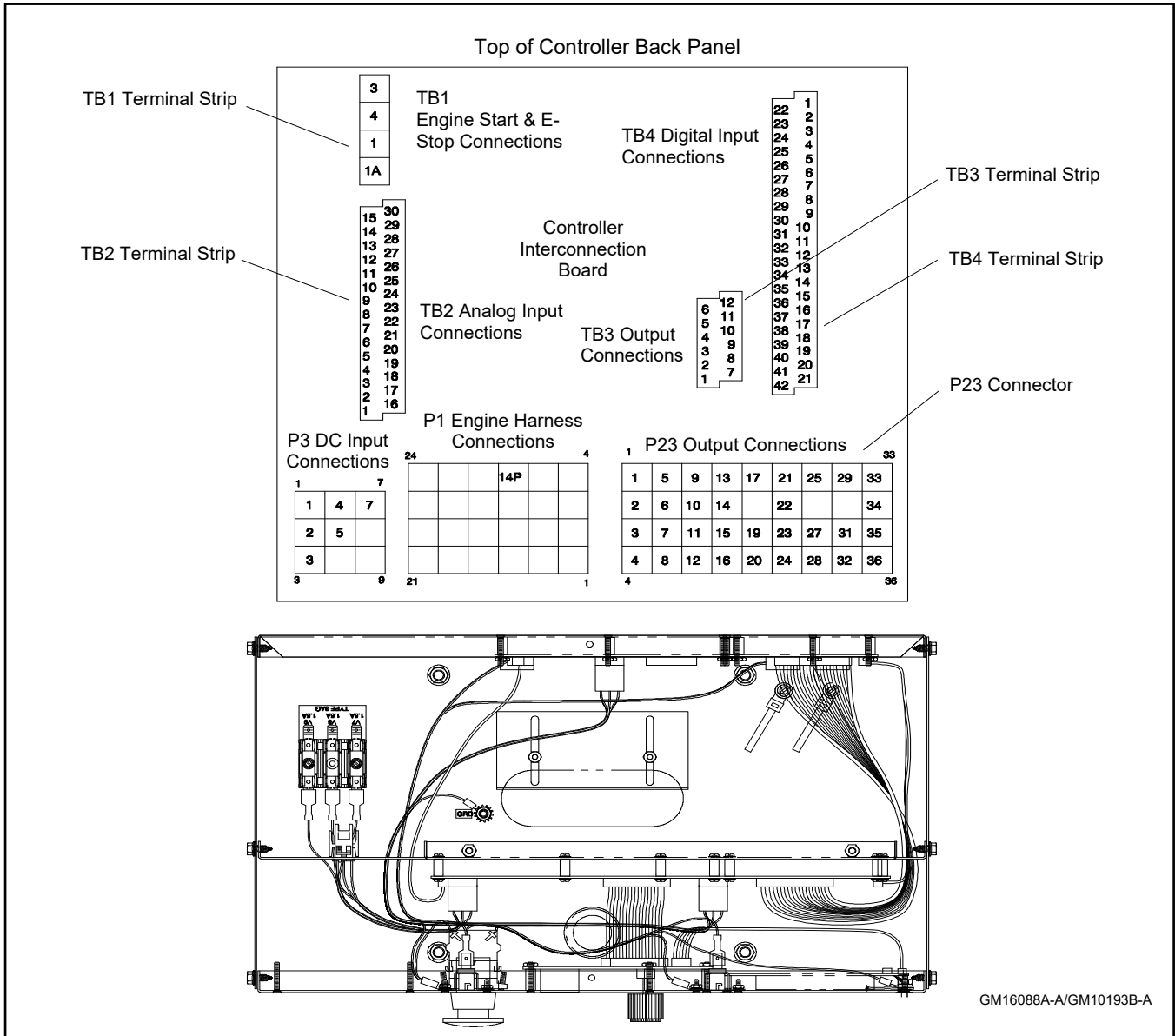
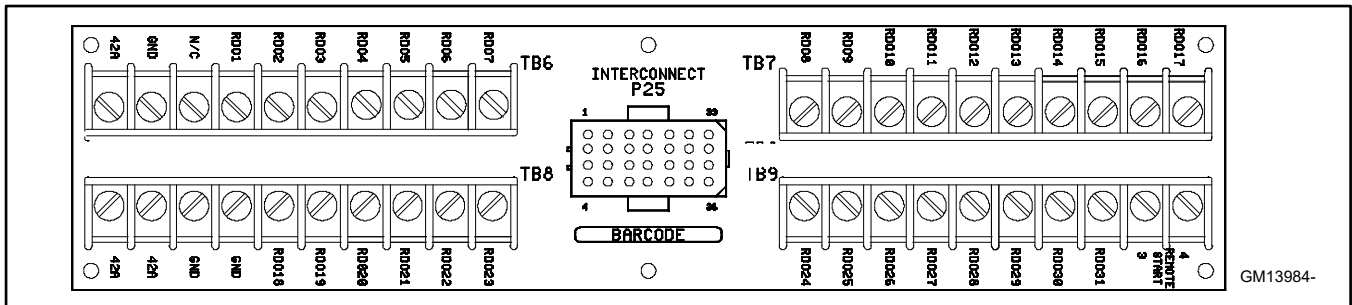

Figure 175 Terminal Strips on Controller Interconnection Circuit Board (Controller Back Panel Folded Down)

TB1 Terminal Strip—Engine Start and Emergency Stop Connections		TB4 Terminal Strip—Input Factory Connections	
Term.	Description	Term.	Description
1	Emergency stop ground	1	DCH1 Battery charger fault
1A	Emergency stop	2	DCH2 Low fuel
3	Remote start	3	DCH3 Low coolant temp. with ECM models or warning default with non-ECM models
4	Remote start	4	DCH4 Field overvoltage with M4/M5/M7 alternators or warning default with non-M4/M5/M7 alternators
TB2 Terminal Strip—Analog Input Connections		5	DCH5 Breaker Closed, Paralleling Applications
Term.	Description	6	DCH6 Enable Synch, Paralleling Applications
1	ACH1 (CTS) Signal (non-ECM including Waukesha)	7	DCH7 Warning
2	ACH1 (CTS) Supply (non-ECM including Waukesha)	8	DCH8 Warning
3	ACH2 (OPS) Signal (non-ECM including Waukesha)	9	DCH9 Warning
4	ACH2 (OPS) Supply (non-ECM including Waukesha)	10	DCH10 Warning
5	ACH3 Signal (air intake temp. for Waukesha)	11	DCH11 AFM Shutdown, Waukesha engine
6	ACH3 Supply (air intake temp. for Waukesha)	12	DCH12 Detonation Warning, Waukesha engine
7	ACH4 Signal (oil temp. for Waukesha)	13	DCH13 Detonation Shutdown, Waukesha engine
8	ACH4 Supply (oil temp. for Waukesha)	14	DCH14 Warning
9	ACH5 Signal	15	DCH15 Remote shutdown
10	ACH5 Supply	16	DCH16 Remote reset
11	ACH6 Signal	17	DCH17 VAR PF mode
12	ACH6 Supply (VSG for Volvo, GM, Doosan)	18	DCH18 Voltage lower
13	ACH7 Signal (optional analog voltage adjust signal)	19	DCH19 Voltage raise
14	ACH7 Supply	20	DCH20 Air damper
15	N/C	21	DCH21 Idle mode functional with ECM-equipped engines only
16	ACH1 (CTS) Return (non-ECM)	22	DCH1 Return
17	ACH1 (CTS) Shield ground (non-ECM)	23	DCH2 Return
18	ACH2 (OPS or OPS2) Return (non-ECM)	24	DCH3 Return
19	ACH2 (OPS) Shield ground (non-ECM)	25	DCH4 Return
20	ACH3 (IAT or OPS1) Return	26	DCH5 Return
21	ACH3 Shield ground	27	DCH6 Return
22	ACH4 (Oil Temp) Return	28	DCH7 Return
23	ACH4 Shield ground	29	DCH8 Return
24	ACH5 Return	30	DCH9 Return
25	ACH5 Shield ground	31	DCH10 Return
26	ACH6 Return	32	DCH11 Return
27	ACH6 Shield ground	33	DCH12 Return
28	ACH7 Return	34	DCH13 Return
29	ACH7 Shield ground	35	DCH14 Return
30	N/C	36	DCH16 Return
TB3 Terminal Strip—Accessory Power Output Connections		37	DCH16 Return
Term.	Description	38	DCH17 Return
1	+12 VDC (OEM use only)	39	DCH18 Return
2	+12 VDC (OEM use only)	40	DCH19 Return
3	+12 VDC (OEM use only)	41	DCH20 Return
4	Fused battery (+) (42A) (5 amp)	42	DCH21 Return
5	Fused battery (+) (42A) (5 amp)		
6	Fused battery (+) (42A) (5 amp)		
7	Battery (-)		
8	Battery (-)		
9	Battery (-)		
10	Battery (-)		
11	Battery (-)		
12	Panel lamp output		

Note: TB4-1 through TB4-21 are user definable with factory defaults listed. Terminals TB4-3, TB4-4, TB4-14, and TB4-21 have different functions depending upon the generator set configuration. See comments above. See Menu 9-Input Setup for changing inputs.

Figure 176 Controller Terminal Strip Identification



GM13984-

Figure 177 Terminal Strips TB6, TB7, TB8, and TB9 on the Controller Connection Kit in the Junction Box

TB6 Terminal Strip—RDOs 1-7		TB9 Terminal Strip—RDOs 24 – 31	
Term.	Description	Term.	Description
42A	Battery (+)	RDO24	Speed sensor fault
GND	Battery (-)	RDO25	Loss of AC sensing
N/C		RDO26	ECM loss of communication
RDO1	Overspeed (lead 39)	RDO27	Undervoltage
RDO2	Overcrank (lead 12)	RDO28	Overfrequency
RDO3	High coolant temperature shutdown (lead 36)	RDO29	Underfrequency
RDO4	Low oil pressure shutdown (lead 38)	RDO30	Load shed kW overload
RDO5	Low coolant temperature (lead 35)	RDO31	Load shed underfrequency
RDO6	High coolant temperature warning (lead 40)	3	Remote start
RDO7	Low oil pressure warning (lead 41)	4	Remote start
TB7 Terminal Strip—RDOs 8-17		Note: Lead numbers shown in parentheses are the factory default wire designations.	
Term.	Description	Note: RDO-1 though RDO-31 are user definable with the following factory defaults: emergency stop, high coolant temperature, low oil pressure, overcrank, and overspeed	
RDO8	Low fuel (lead 63)	*NFPA-110 common alarm faults include:	
RDO9	Master switch not in auto (lead 80)	Air damper indicator (RDO-23)	
RDO10	NFPA 110 common alarm (lead 32)*	Battery charger fault (RDO-11)	
RDO11	Battery charger fault (lead 61)	EPS supplying load (RDO-22)	
RDO12	Low battery voltage (lead 62)	High battery voltage (RDO-13)	
RDO13	High battery voltage	High coolant temperature warning (RDO-06)	
RDO14	Emergency stop (lead 48)	High coolant temperature shutdown (RDO-03)	
RDO15	Generator set running (lead 70R)	Low battery voltage (RDO-012)	
RDO16	Time delay engine cooldown (TDEC) (lead 70C)	Low coolant level (RDO-19)	
RDO17	System ready (lead 60)	Low coolant temperature warning (RDO-05)	
TB8 Terminal Strip—RDOs 18-23		Low fuel (level or pressure) (RDO-08)	
Term.	Description	Low oil pressure warning (RDO-07)	
42A	Battery (+)	Low oil pressure shutdown (RDO-04)	
42A	Battery (+)	Master switch not in auto (RDO-09)	
GND	Battery (-)	Overcrank (RDO-02)	
GND	Battery (-)	Overspeed (RDO-01)	
RDO18	Defined common fault (lead 32A)		
RDO19	Low coolant level		
RDO20	Overvoltage (lead 26)		
RDO21	Idle mode		
RDO22	EPS supplying load		
RDO23	Air damper indicator (lead 56)		

Figure 178 Controller (Customer) Connection Kit Terminal Strip Identification with Relay Driver Outputs (RDOs)

Section 11. Decision-Maker 3500 Controller Accessories

11.1 Accessories and Connections

Several accessories help finalize installation, add convenience to operation and service, and establish state and local code compliance.

Accessories vary with each generator set model and controller. Select factory-installed and/or shipped-loose accessories. See Figure 179 for a list of available kits. Obtain the most current accessory information from your local authorized service distributor/dealer.

This section illustrates several accessories available at print time of this publication. Accessory kits generally include installation instructions. See wiring diagrams manual for electrical connections not shown in this section. See the installation instructions and drawings supplied with kit for information on kit mounting location.

The instructions provided with the accessory kit supersede these instructions where there are differences. In general, run AC and DC wiring in separate conduit. Use shielded cable for all analog inputs. Observe all applicable national, state, and local electrical codes during accessory installation.

See the following subsection, Accessory Connections, for terminal identification.

Kit Description
Fifteen-Relay Dry Contact
Remote Emergency Stop
Remote Serial Annunciator (RSA III)

Figure 179 Optional Accessories

11.1.1 Fifteen-Relay Dry Contact Kit

The 15-relay dry contact board has four digital inputs and two analog inputs. There are 14 individual relay driver outputs (RDOs) with one common fault RDO.

See Figure 180 for circuit board components and electrical connections to the controller. See Figure 181 for connections of analog inputs.

See the following subsection, "Accessory Connections," for terminal identification.

The normally open (NO) relay contacts are rated:

- 10 amp @ 120 VAC
- 10 amp @ 28 VDC (max.)
- 10 amp @ 28 VDC (min.)

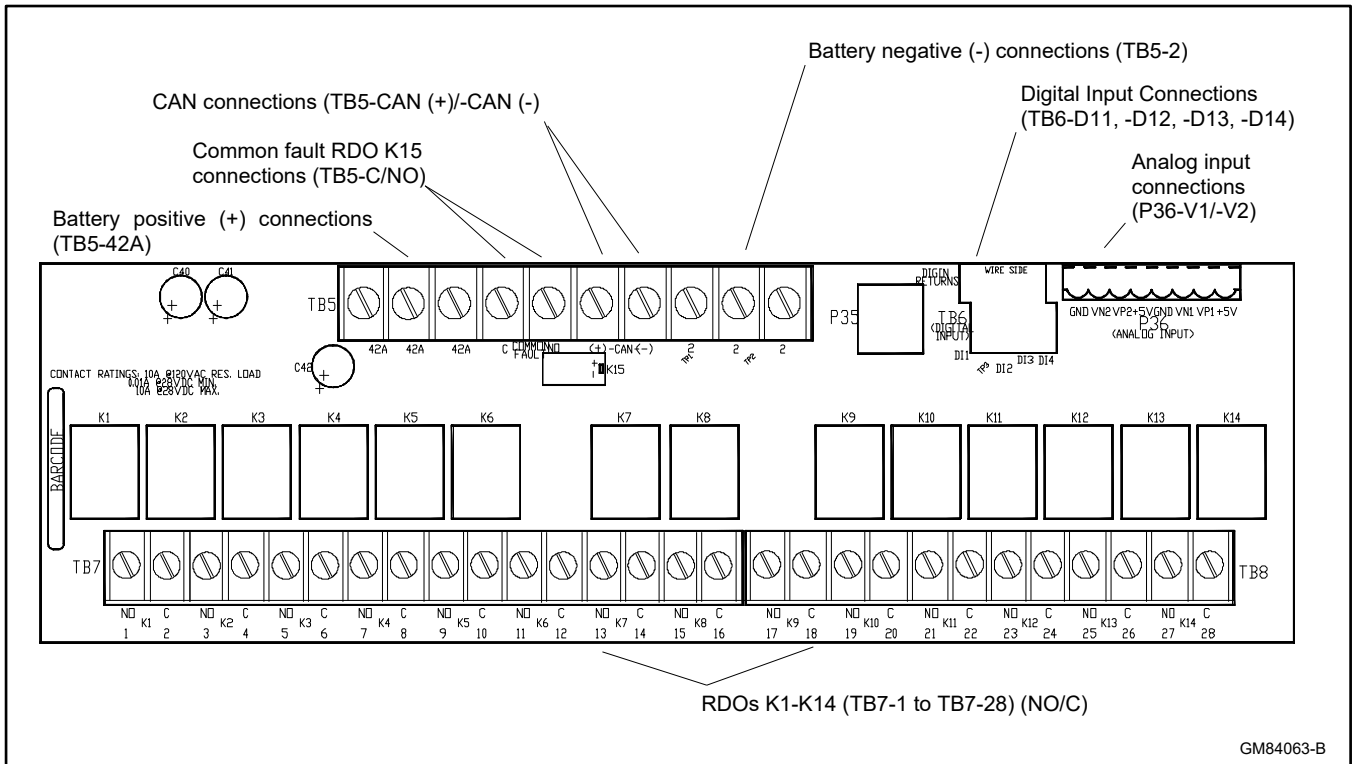

Figure 180 15-Relay Dry Contact Board

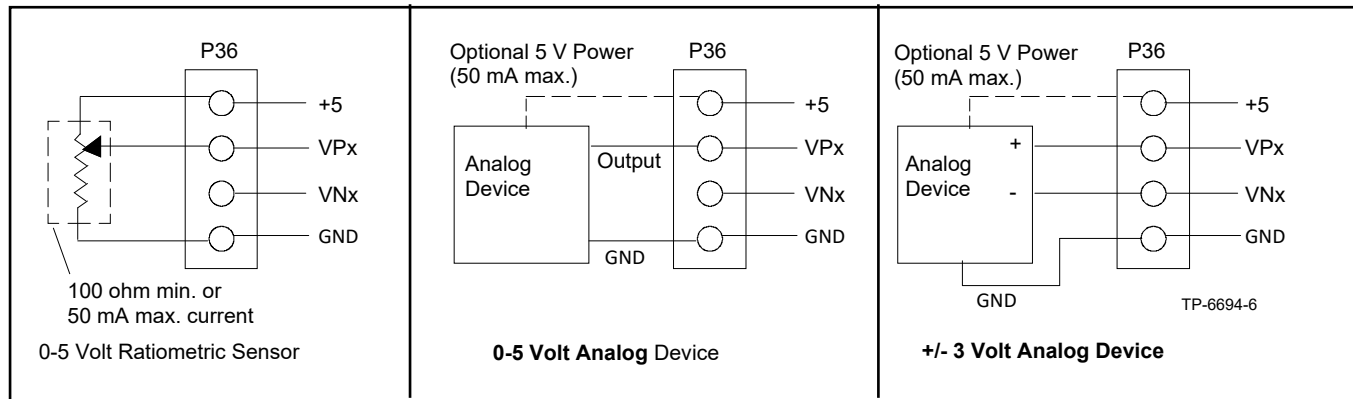

Figure 181 Analog Input Connections P36

11.1.2 Remote Emergency Stop Kit

The emergency stop kit allows immediate shutdown of the generator set from a remote location. See the following figures for connection details. Install the emergency stop switch in a location that is easily accessible by operating personnel. Connect as many emergency stop switches as required; however, connect multiple switches in series so the system functions correctly.

Two emergency stop kits are available. See the image below.

- For the emergency stop switch, use the single glass piece located inside the switch for replacement and order additional glass pieces as service parts. See the respective operation manual for the Emergency Stop Switch Reset Procedure. See the following subsection, "Accessory Connections," for terminal identifications.
- The lockable emergency stop kit allows the installation of a lockout/tagout device to lock the switch in the STOP position. Insert a locking device through the openings in the shroud to prevent resetting the switch.

Refer to the instructions provided with the kit for installation instructions.

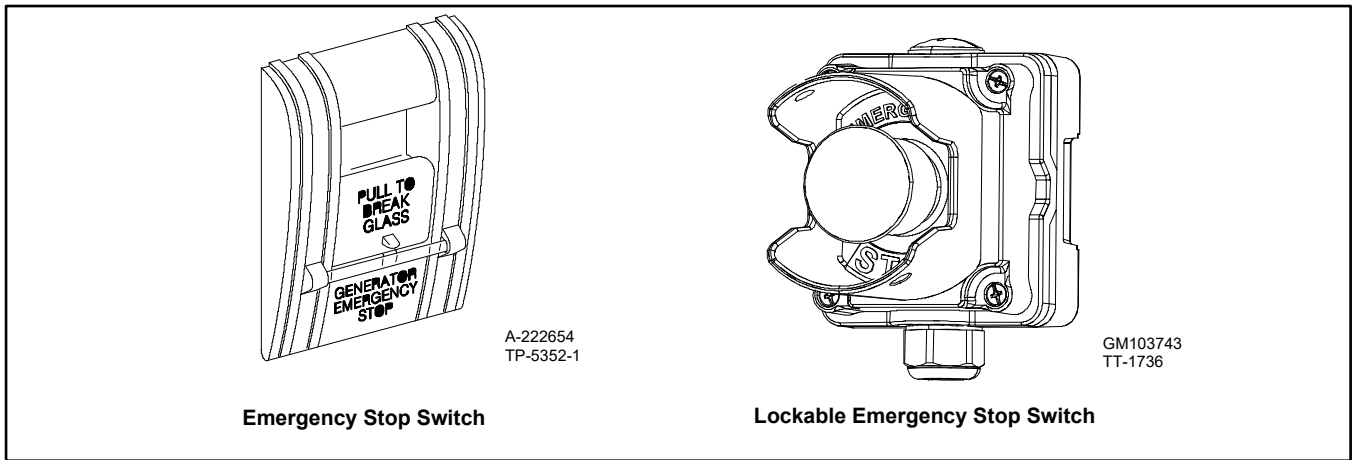

Figure 182 Emergency Stop Kits

See Figure 183 for typical connections. Refer to the generator set wiring diagram for your model. See the following subsection, "Accessory Connections," for terminal identifications.

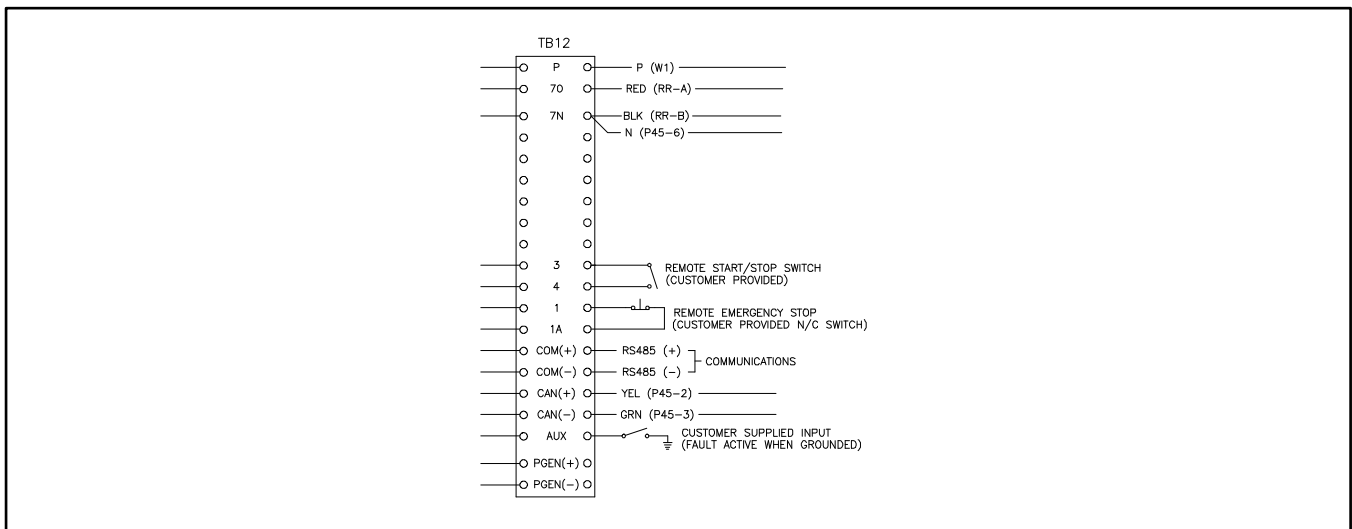

Figure 183 Remote E-Stop Kit Connections

11.1.3 Remote Serial Annunciator (RSA III)

Refer to the RSA III installation instructions, TT-1625.

RSA III is an annunciator panel offered in several kit configurations to support power equipment. The RSA III is a remote serial annunciator that monitors the condition of the generator set and/or ATS from a remote location. The RSA III alerts the operator through visual and audible signals using LED indication and a horn. An alarm silence and lamp test switch are included.

The RSA III meets NFPA 110, Level 1 (2005) applications that require remote controls and alarms to be powered by a storage battery such as the engine starting battery. AC adaptor kit GM62466-KP1 is available when NFPA is not required.

A personal computer (PC) with SiteTech™ software is required to make the RSA III functional. SiteTech™ is available to authorized distributors and dealers.

An RSA III annunciator can be used for a single generator set or with a combination of a generator set and automatic transfer switch(es). In systems using more than a single RSA III, one must be designated as the master device to broadcast to additional RSA III annunciators, designated as slave devices. Up to five RSA III slave devices can be used with an RSA III master device. All RSA III annunciators are factory set as the master device, but can be changed to a slave device using a personal computer (PC) and SiteTech™ software that connects to the RSA III front panel via a universal serial bus (USB) connection.

For long distances and to reduce electrical noise, a lower baud rate, such as 19200, is recommended. See TT-1625 for more details.

Use SiteTech™ software to select that either the generator set controller or the transfer switch activates the EPS Supplying Load LED.

See the subsection, Accessory Connections, for terminal identifications.



Figure 184 Remote Serial Annunciator (RSA III)

Wiring

- For communication between the controller and RSA III master, see the figure below, P27 Connector on Master RSA III.
- For communication between RSA III Master and RSA III Slave, see the figure below, P27 Connection on RSA III Slave.
- Refer to the generator set wiring diagram for the RSA connections to the controller.
- If five or more devices are connected, place a terminating resistor on the last RSA III slave in the daisy chain connection.

Note:

When using RS-485 communication cable, connect the “shield” wire at either end but not at both ends.

P27 RS-485 Connections (from Controller to Master)	
P27-1	(-) Black (from controller)
P27-2	(+) White (from controller)
P27-3	Shield (from controller)
P27-4	(-) Black (to slave or terminating resistor)
P27-5	(+) White (to slave or terminating resistor)
P27-6	Shield (to slave or open)
Note: When using RS-485 communication cable, connect the “shield” wire at either end but not at both ends.	

Figure 185 P27 Connector on Master RSA III

Communication between RSA III Master and RSA III Slave. Select and connect the RS-485 wiring from the RSA III master to the RSA III slave(s) in a daisy chain wiring configuration. The figure below, “P27 Connection on RSA III Slave,” shows the master/slave RS-485 connections and “RSA III Circuit Board GM86125 Connectors” shows the RSA III with P27 location.

- For communication connections, use #12-24 AWG shielded, twisted-pair communication cable. For indoor, non-plenum installations, Belden #9841 or equivalent cable is recommended.
- For outdoor or plenum installations, including those with buried cables and/or conduit, use outdoor-rated cable, Belden 3105DB or 3106DN or equivalent.

All wiring must comply with applicable national and local codes.

P27 RS-485 Connections (from Master to Slave)	
P27-1	(-) Black (from master or previous slave)
P27-2	(+) White (from master or previous slave)
P27-3	Shield (from master or previous slave)
P27-4	(-) Black (to next slave or terminating resistor)
P27-5	(+) White (to next slave or terminating resistor)
P27-6	Shield (to next slave or open)
Note: When using RS-485 communication cable, connect the "shield" wire at either end but not at both ends.	

Figure 186 P27 Connection on RSA III Slave

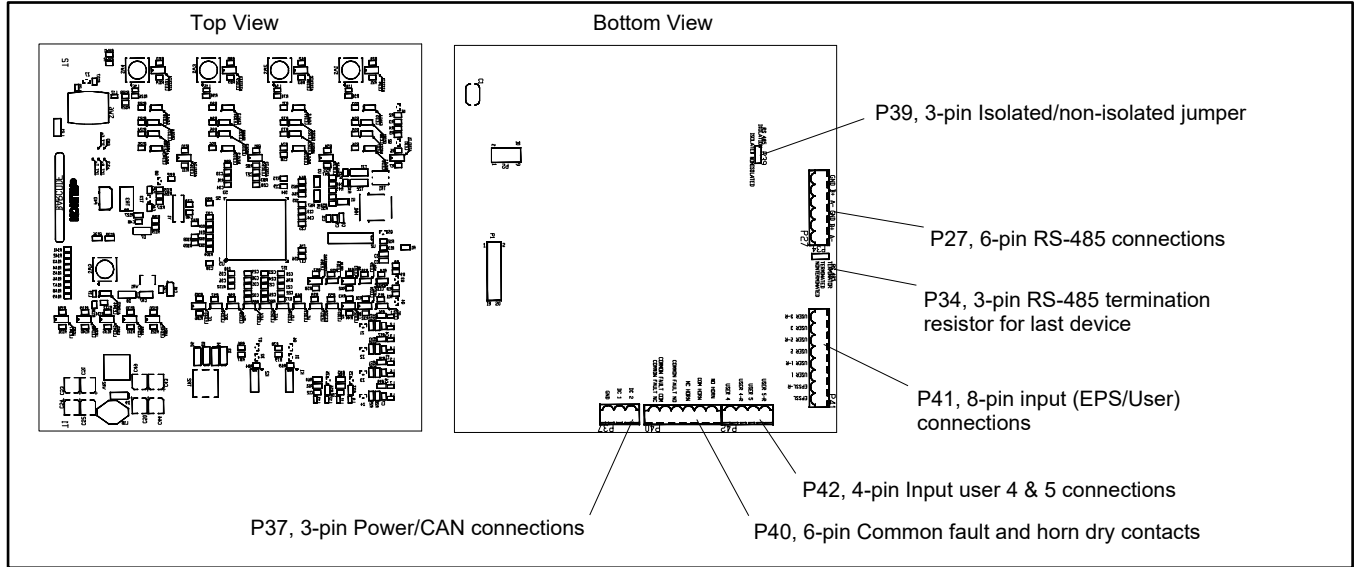

Figure 187 RSA III Circuit Board GM86125 Connectors

11.2 Accessory Connections

The controller contains a circuit board equipped with connectors for use in connecting external optional accessories including alarms, battery chargers, and remote switches. The optional fifteen relay dry contact board provides an additional four digital inputs and two analog inputs.

For specific information on accessory connections, refer to the accessory wiring diagrams in the wiring diagram manual and the instruction sheet accompanying the kit.

Circuit Board Connections (see Figure 188)

DEC 3500 Controller Front Panel (see Figure 189)

Panel Power Connections (see Figure 189)

P1 (35-Pin) Connector for engine/generator wiring harness.

P2 (14-Pin) Connector for sensor input connections and relay driver output connections.

P3 (8-Pin) Connector for generator set output voltage connection and paralleling bus voltage sensing connections.

P4 (Ethernet) RG 45 Connector connects to a network communication line.

P7 (10-Pin) Connector for factory use only.

Mini USB Connector for connection of a PC with SiteTech™ software programming or for firmware updates.

TB10 Terminal Strip for CAN, remote emergency stop, and remote start connections.

See Figure 190 for controller circuit board connections. See the appendix, Wiring Diagrams, for accessory connection wiring diagrams.

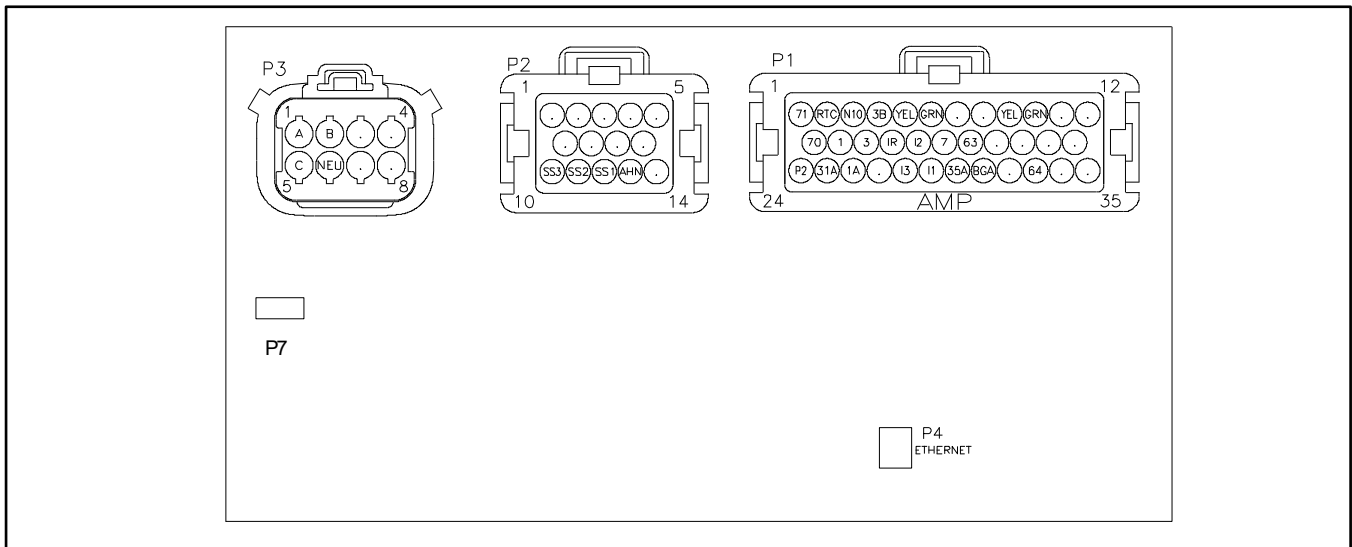

Figure 188 Main Circuit Board Connectors (Back of DEC 3500 Controller)

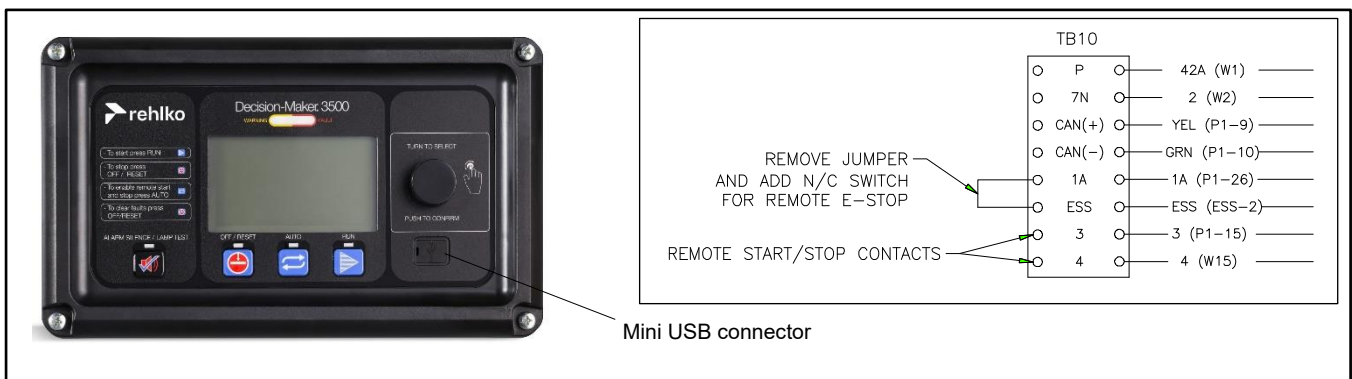

Figure 189 DEC 3500 Controller Front Panel

P1 35-Pin Connector		
Engine/Generator Wiring Harness		
Terminal	Description	Connection
P1-1	71	P31-3 (71)
P1-2	RTC	P48-23 (RTC)
P1-3	N10	P48-31 (14N1)
P1-4	3B	P7-8 (3B)
P1-5	YEL	P48-34 (YEL)
P1-6	GRN	P48-33 (GRN)
P1-7	Open	-
P1-8	Open	-
P1-9	YEL	TB10-CAN (+)
P1-10	GRN	TB10-CAN (-)
P1-11	Open	-
P1-12	Open	-
P1-13	70	P30-3 (70)
P1-14	1	ESS-1 (local E-stop)
P1-15	3	TB10-3
P1-16	IR	P7-4 (IR)
P1-17	12	P7-2 (I2)
P1-18	7	P48-22 (7)
P1-19	63	P48-21 (63)
P1-20	Open	-
P1-21	Open	-
P1-22	Open	-
P1-23	Open	-
P1-24	P2	P4B-9 (P1)
P1-25	31A	P48-15 (31A)
P1-26	1A	TB10-1A
P1-27	Open	-
P1-28	13	P7-3 (I3)
P1-29	11	P7-1 (I1)
P1-30	35A	P48-14 (35A)
P1-31	BGA	P48-31 (14N1)
P1-32	Open	-
P1-33	64	P7-11 (64)
P1-34	Open	-
P1-35	Open	-

P2 14-Pin Connector		
Analog/Digital Input and Relay Driver Output Connections		
Terminal	Description	Connection
P2-1	Open	-
P2-2	Open	-
P2-3	Open	-
P2-4	Open	-
P2-5	Open	-
P2-6	Open	-
P2-7	Open	-
P2-8	Open	-
P2-9	Open	-
P2-10	SS3	P7-7
P2-11	SS2	P7-6
P2-12	SS1	P7-5
P2-13	AHN	P4B-1
P2-14	Open	-

P3 8-Pin Connector		
Output Voltage and Paralleling Bus Voltage Sensing Connections		
Terminal	Description	Connection
P3-1	A	IS15
P3-2	B	IS16
P3-3	Open	-
P3-4	Open	-
P3-5	C	IS17
P3-6	NEU	IS18
P3-7	Open	-
P3-8	Open	-

TB10 8-Position Terminal Strip		
CAN, Remote E-Stop, and Remote Start Connections		
Terminal	Description	Connection
TB10-1	P	42A Battery (+)
TB10-2	7N	2 Battery (-)
TB10-3	CAN (+)	P1-9
TB10-4	CAN (-)	P1-10
TB10-5	1A	Remote E-Stop
TB10-6	ESS	Remote E-Stop
TB10-7	3	Remote start (ATS)
TB10-8	4	Remote start (ATS)

P4 Connector	
RJ45 Ethernet	
Terminal	Description
Open	Network communications

Figure 190 Controller Connections

Notes

Section 12. Decision-Maker 6000 Controller Accessories

12.1 Accessories and Connections

Several accessories help finalize installation, add convenience to operation and service, and establish state and local code compliance.

Accessories vary with each generator set model and controller. Select factory-installed and/or shipped-loose accessories. See the figure below, Optional Accessories, for a list of available kits. Obtain the most current accessory information from your local authorized service distributor/dealer.

This section illustrates several accessories available at print time of this publication. Accessory kits generally include installation instructions. See wiring diagrams manual for electrical connections not shown in this section. See the installation instructions and drawings supplied with kit for information on kit mounting location.

The instructions provided with the accessory kit supersede these instructions where there are differences. In general, run AC and DC wiring in separate conduit. Use shielded cable for all analog inputs. Observe all applicable national, state, and local electrical codes during accessory installation.

Kit Description
Audiovisual Alarm
Common Failure Relay (Terminal 32A)
Controller (Customer) Connection
Float/Equalize Battery Charger (with alarms)
Ground Fault Annunciation
Idle (Speed) Mode Feature
Low Fuel (Level) Switch
Low Fuel (Pressure) Switch
Prime Power Switch
Remote Emergency Stop
Remote Reset Feature
Remote Serial Annunciator (RSA III)
Shunt-Trip Line Circuit Breaker and Shunt-Trip Wiring
Single-Relay Dry Contact
Ten-Relay Dry Contact
Twenty-Relay Dry Contact

Figure 191 Optional Accessories

12.1.1 Audiovisual Alarm Kit

An audiovisual alarm warns the operator at a remote location of fault shutdowns and prealarm conditions. Audiovisual alarms include an alarm horn, an alarm silence switch, and common fault lamp. See the figures below for connections. See the following subsection, "Accessory Connections," for terminal identification.

Note:

Use the audiovisual alarm with a dry contact kit

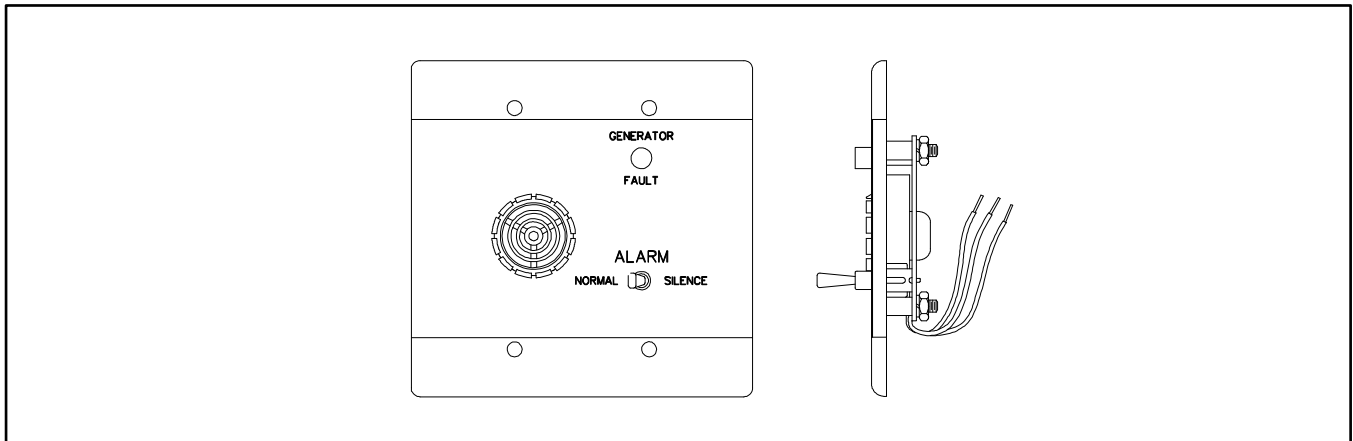

Figure 192 Audiovisual Alarm

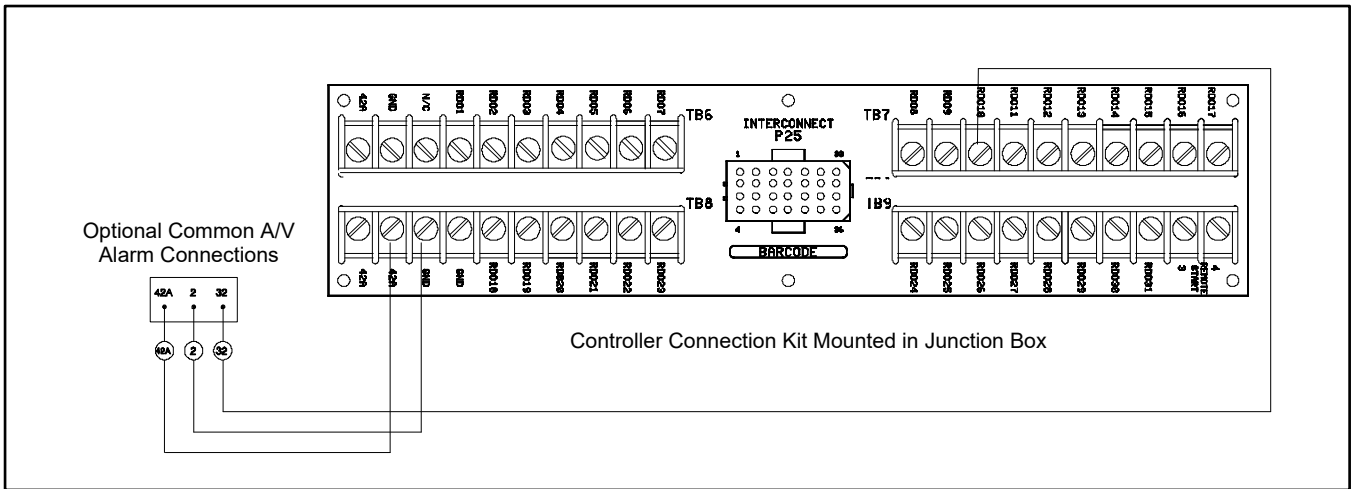

Figure 193 Audiovisual Alarm Connections

12.1.2 Common Failure Relay Kit

The common failure relay kit provides one set of contacts to trigger user-provided warning devices if a fault occurs. The common failure relay faults are user-defined. See the respective operation manual for status and faults available for this function.

Connect up to three common failure relay kits to the controller output. See the figures below for connections. See the following subsection on "Accessory Connections" for terminal identification.

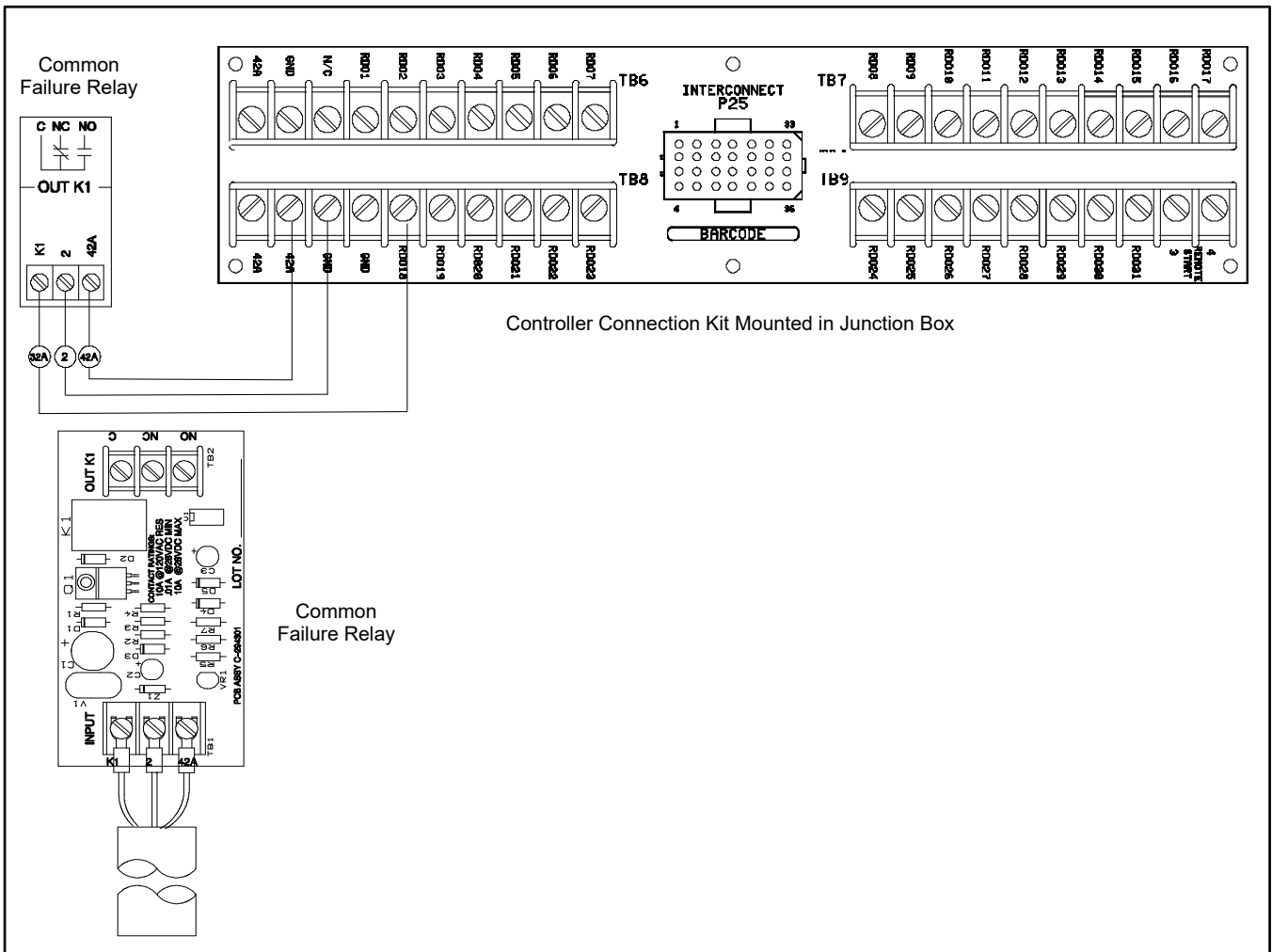

Figure 194 Common Failure Relay Kit Connections

12.1.3 Float/Equalize Battery Charger Kit with Alarm Option

The float/equalize battery charger with alarm option provides battery charging to the engine starting battery(ies) and connects to the controller for fault detection. Battery chargers for 12- or 24-volt models are available as a generator set accessory. See the figure below for connection details. See the following subsection, "Accessory Connections," for terminal identification.

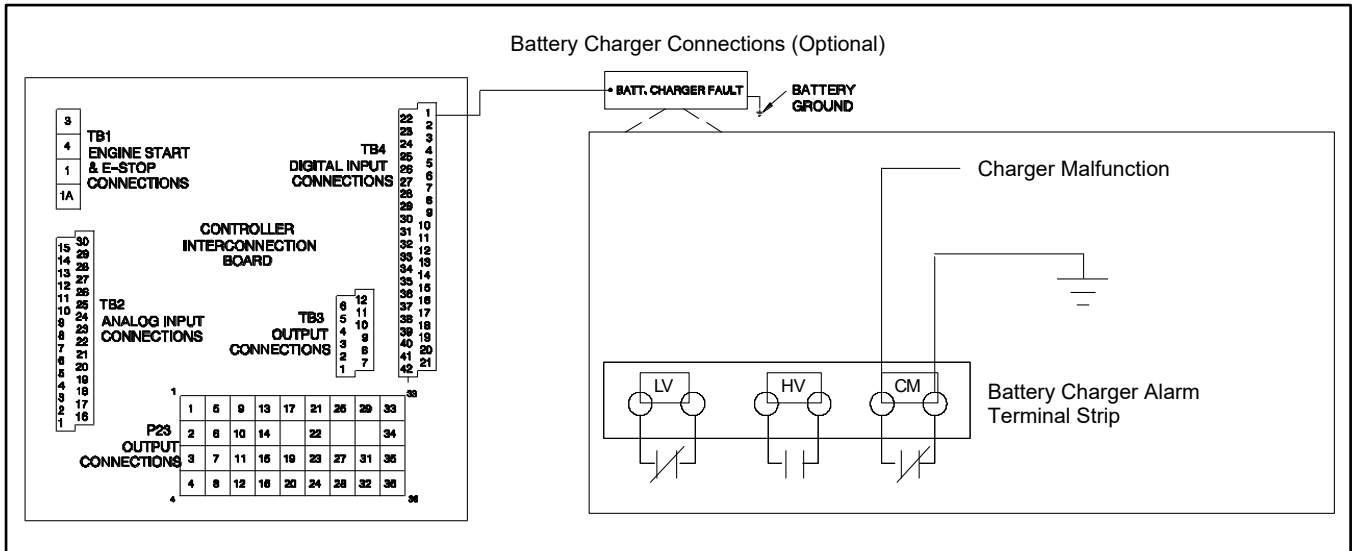

Figure 195 Float/Equalize Battery Charger Connections

12.1.4 Ground Fault Annunciation

<p>⚠ WARNING</p>	<p>Accidental starting. Can cause severe injury or death.</p> <p>Disconnect the battery cables before working on the generator set. Remove the negative (-) lead first when disconnecting the battery. Reconnect the negative (-) lead last when reconnecting the battery.</p>
-------------------------	---

Disabling the generator set. Accidental starting can cause severe injury or death. Before working on the generator set or equipment connected to the set, disable the generator set as follows: (1) Press the generator set off/reset button to shut down the generator set. (2) Disconnect the power to the battery charger, if equipped. (3) Remove the battery cables, negative (-) lead first. Reconnect the negative (-) lead last when reconnecting the battery. Follow these precautions to prevent the starting of the generator set by the remote start/stop switch.

A relay contact for customer connection indicates a ground fault condition and is part of a ground fault alarm. See the figure below for electrical connections and the steps in the following procedure for controller setup. Use the instructions with the kit when provided to install and setup this accessory.

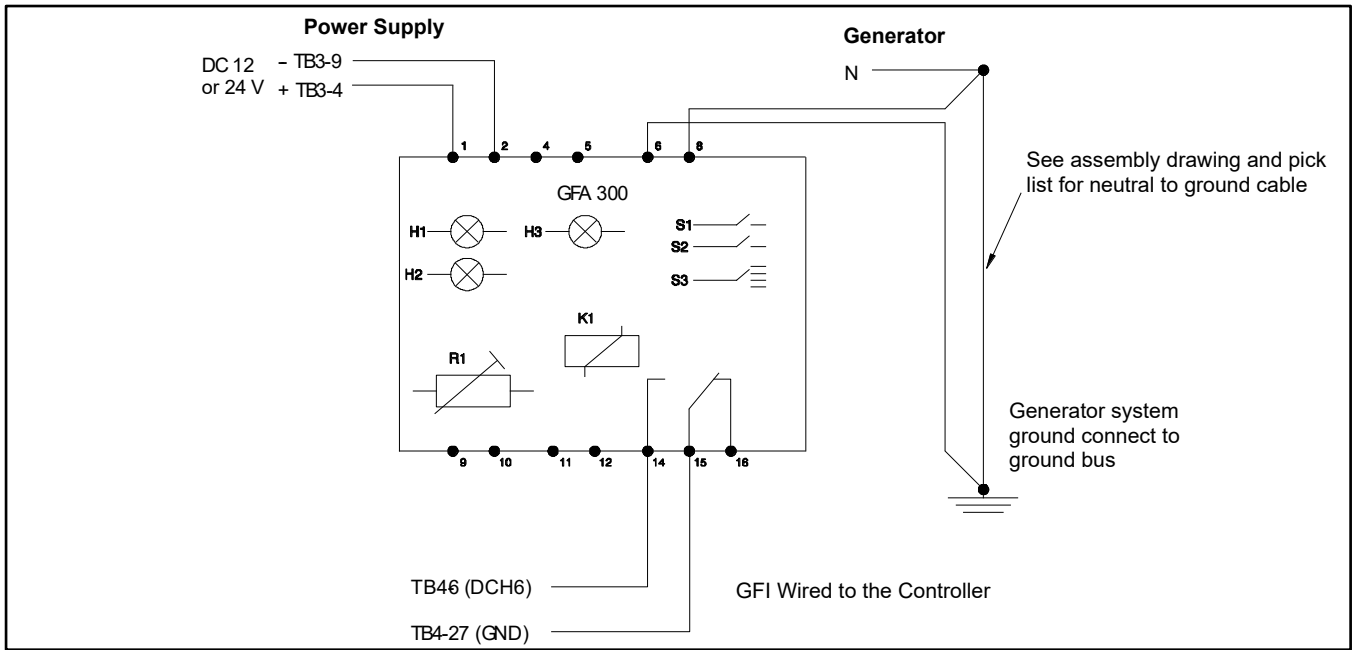



Figure 196 Ground Fault Connections



Ground Fault Controller Setup Procedure

13. Reconnect battery, if not already done.
14. Place the controller master switch to the AUTO position.
15. Press the Alarm Off key to silence the alarm horn, if necessary.
16. If the programming mode LED is not flashing, go to the step 5. If the programming mode LED is flashing, go to step 6.
17. Set Programming Mode to Local.



a. Press keys     

b. Press key  until Programming Mode- Local is displayed.

c. Press the YES   key.











d. When the Enter Code displays, press the factory default   or the user password keys and  The programming mode LED should be flashing.

18. Set digital input #6 to ground fault.

a. Press    Menu 9 Input Setup should be displayed.

b. Press  until Digital Input 06 warning is displayed.











c. Press  once to select this input.

- d. Press  until Ground Fault is displayed.
- e. Press   to define Digital Input #06 as ground fault. Entry Accepted is displayed.
- f. Press  to display Digital Input #06 Inhibit Time.
- g. Press   to enter the inhibit time. Entry Accepted is displayed and the inhibit time 0:00 is now displayed.
- h. Press  display Digital Input #006 Delay Time.
- i. Press   enter delay time. Entry Accepted is displayed. Default delay time is 5 sec.
- j. Press .

19. Verify Programming.

- a. Move handle of ground fault circuit breaker at generator set to simulate a ground fault.
- b. Verify that display shows D06 Ground Fault. The System Warning LED should be illuminated and the alarm horn should sound. If these indicators are not present, recheck steps 6a. through 6j.
- c. Return handle of ground fault circuit breaker to the non-ground fault position. D06 Ground Fault display should now be cleared.

20. Set Programming Mode to Off.

- a. Press    .
- b. Press key  until Programming Mode Off is displayed.
- c. Press the YES key  .
- d. When the Enter Code displays, press the factory default   or the user password keys and . The programming mode LED should now be off.

- 21. Place the controller master switch to the OFF/RESET position.
- 22. Disconnect the battery negative (-) lead to power down the generator set.
- 23. After 2–3 minutes, reconnect the battery negative (-) lead.
- 24. Reset the controller clock. See Menu 6 – Time and Date.

12.1.5 Idle (Speed) Mode Feature

The idle (speed) mode feature provides the ability to start and run the engine at idle (reduced) speed for a selectable time period (0-10 minutes) during warm-up. The controller will override the idle speed mode if the engine reaches the preprogrammed engine warmed-up temperature before the idle mode times out. See the figure below for user-supplied switch connection.

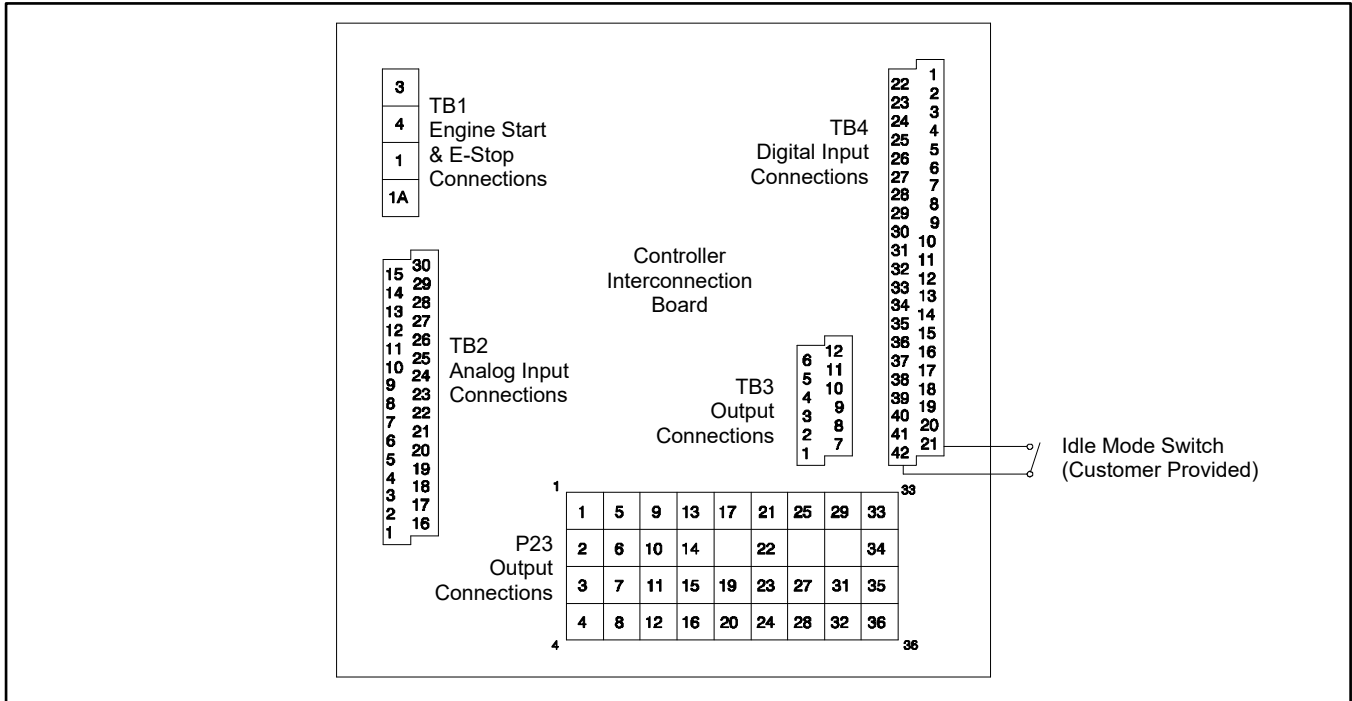

Figure 197 Idle (Speed) Mode Switch

12.1.6 Low Fuel (Level/Pressure) Switch

Some gaseous-fueled models offer a low fuel pressure switch. The low fuel pressure switch connects to the gasoline-fueled models. See the figures below for connection details. See the following subsection, "Accessory Connections, for terminal identification.

Note:

The main tank or the transfer/day tank includes the low fuel level switch. The fuel tank supplier typically provides the low fuel level switch.

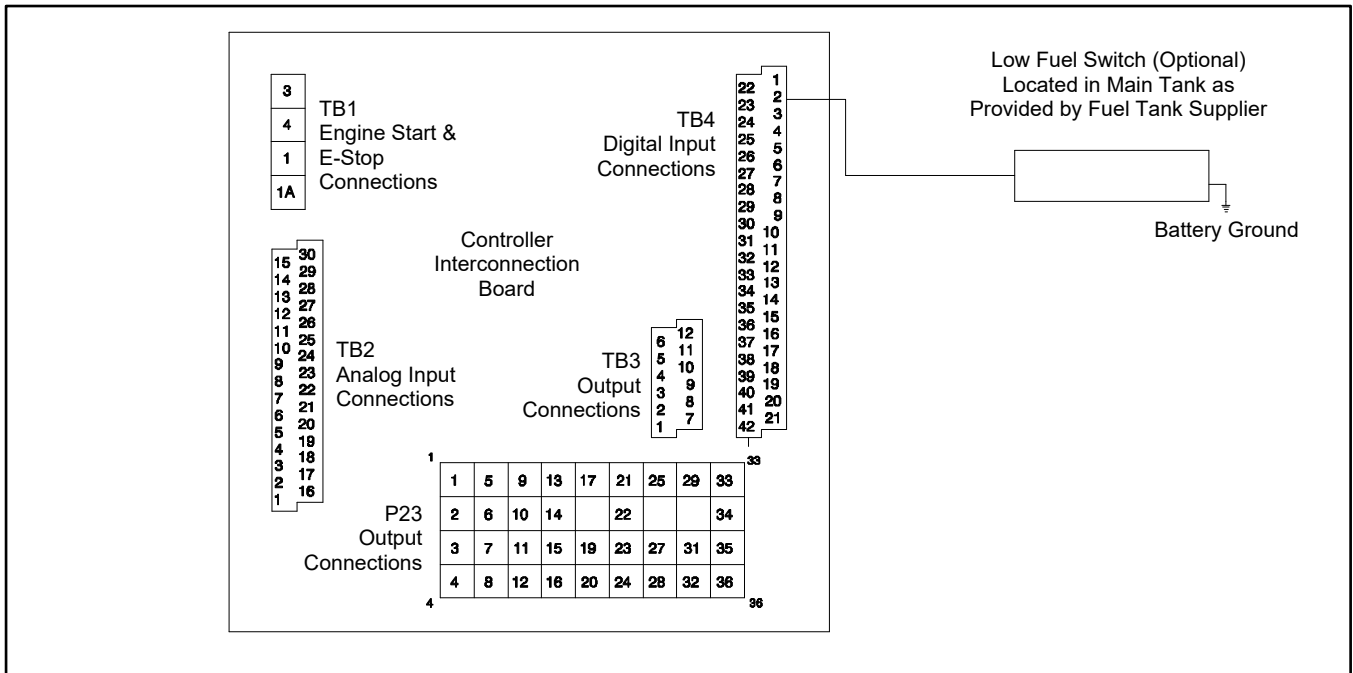

Figure 198 Low Fuel Switch (Level or Pressure)

Switch Rating	12 volts DC minimum, 0.5 amp minimum
Wiring Recommendation	
Gauge	mm (ft.)
18-20	30.5 (100)
14	153 (500)
10	305 (1000)

Figure 199 Switch Rating and Wiring Recommendations

12.1.7 Prime Power Switch Kit

The prime power switch kit prevents battery drain during generator set nonoperation periods and when the generator set battery cannot be maintained by an AC battery charger. See the figures below for an illustration of the kit and the electrical connections

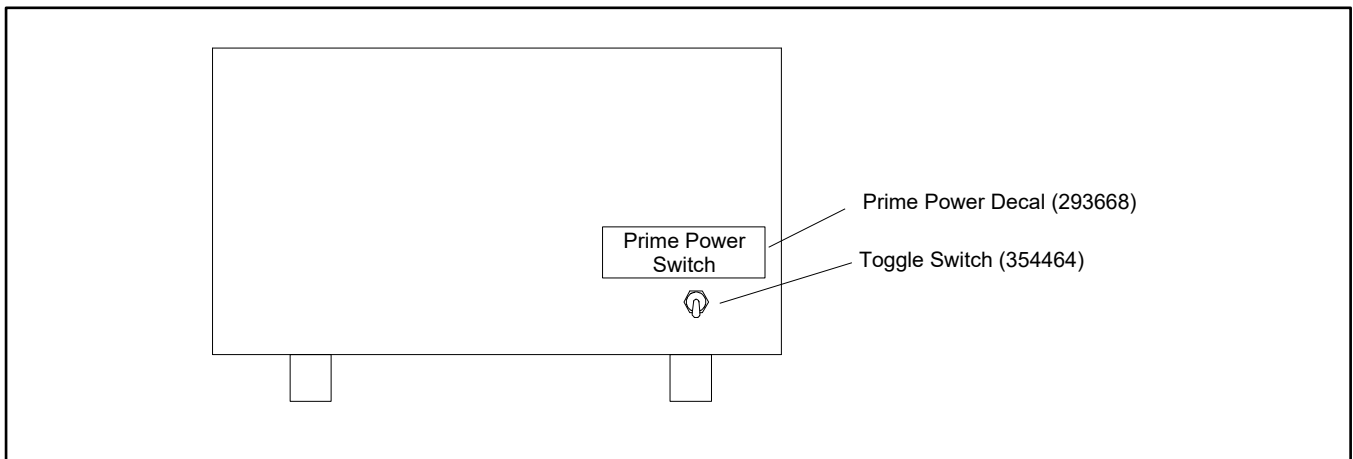

Figure 200 Prime Power Switch Installation Location

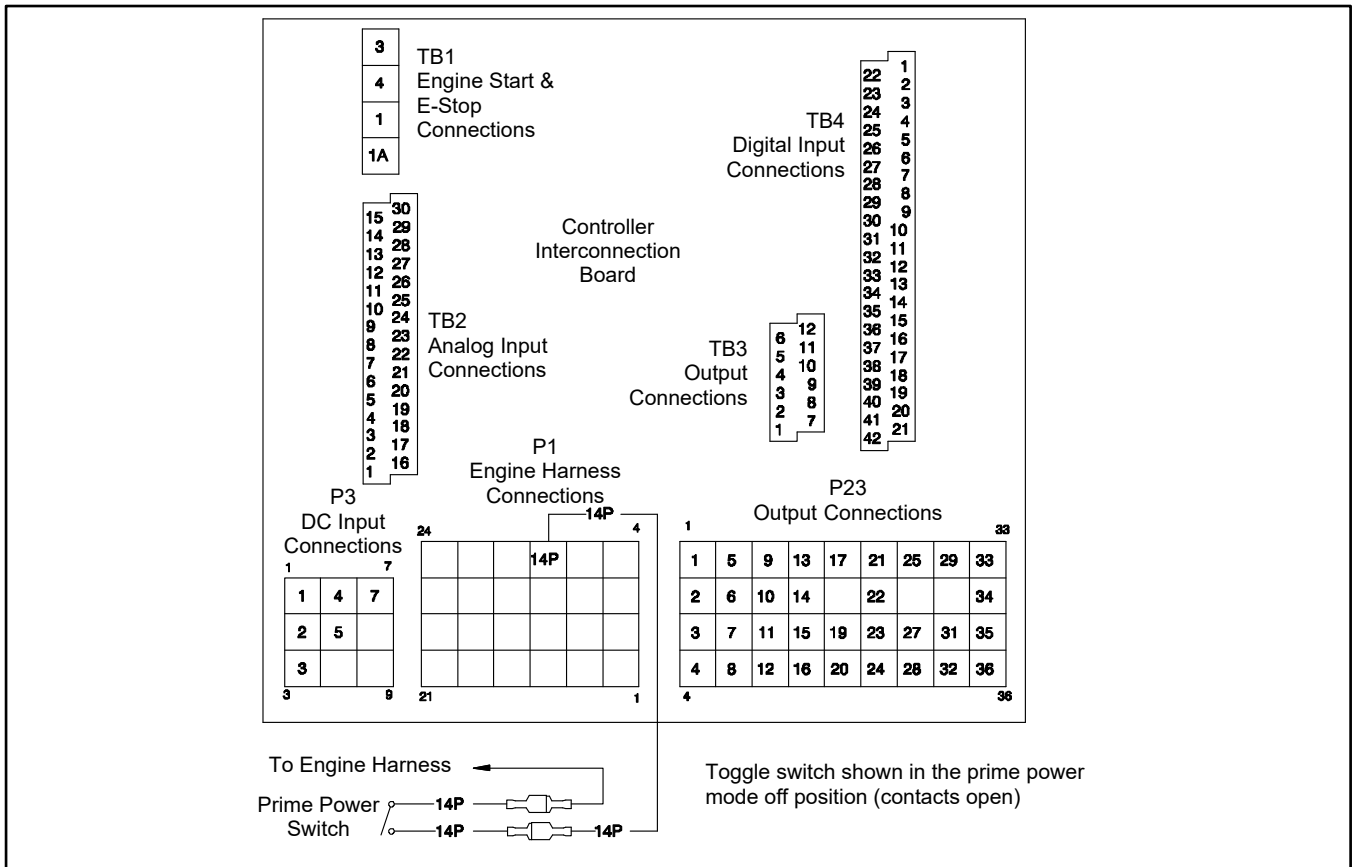

Figure 201 Prime Power Switch Connection

Stop the generator set using the stopping procedures in the respective operation manual before placing the generator set in the prime power mode. Move the prime power switch located on the back of the controller to the DOWN position. The controller including the digital display, LEDs, and alarm horn does not function when the generator set is in the prime power mode.

Move the prime power switch located on the back of the controller to the UP position and reset the controller time and date before attempting to start the generator set.

12.1.8 Remote Emergency Stop Kit

The emergency stop kit allows immediate shutdown of the generator set from a remote location. See the following figures for connection details. Install the emergency stop switch in a location that is easily accessible by operating personnel. Connect as many emergency stop switches as required; however, connect multiple switches in series so the system functions correctly.

Two emergency stop kits are available. See the image below.

- For the emergency stop switch, use the single glass piece located inside the switch for replacement and order additional glass pieces as service parts. See the respective operation manual for the Emergency Stop Switch Reset Procedure. See the following subsection, "Accessory Connections," for terminal identifications.
- The lockable emergency stop kit allows the installation of a lockout/tagout device to lock the switch in the STOP position. Insert a locking device through the openings in the shroud to prevent resetting the switch.

Refer to the instructions provided with the kit for installation instructions.

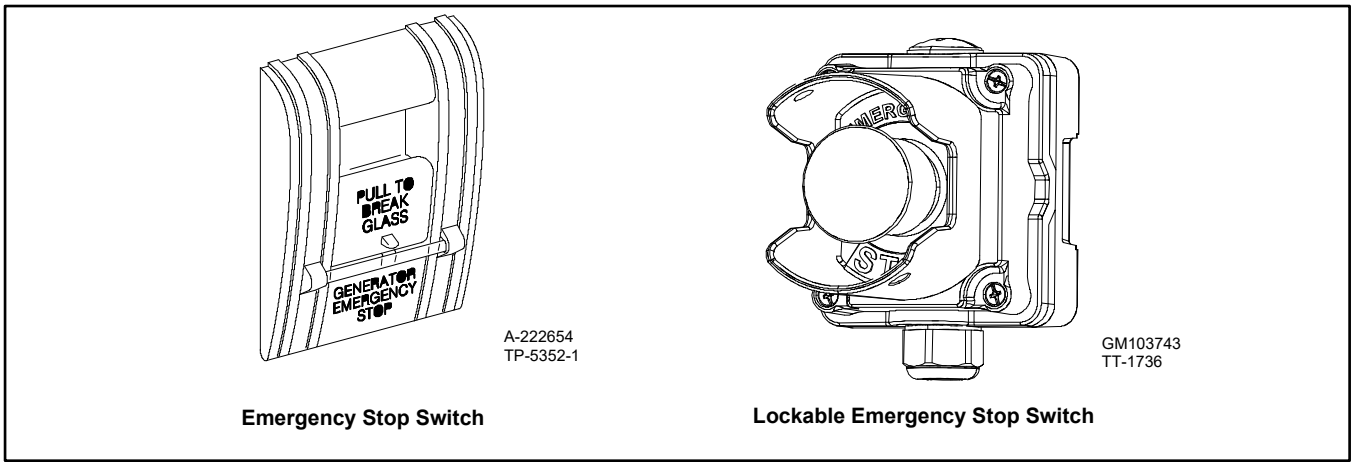

Figure 202 Emergency Stop Kits

See the figure below for typical connections. Refer to the generator set wiring diagram for your model.

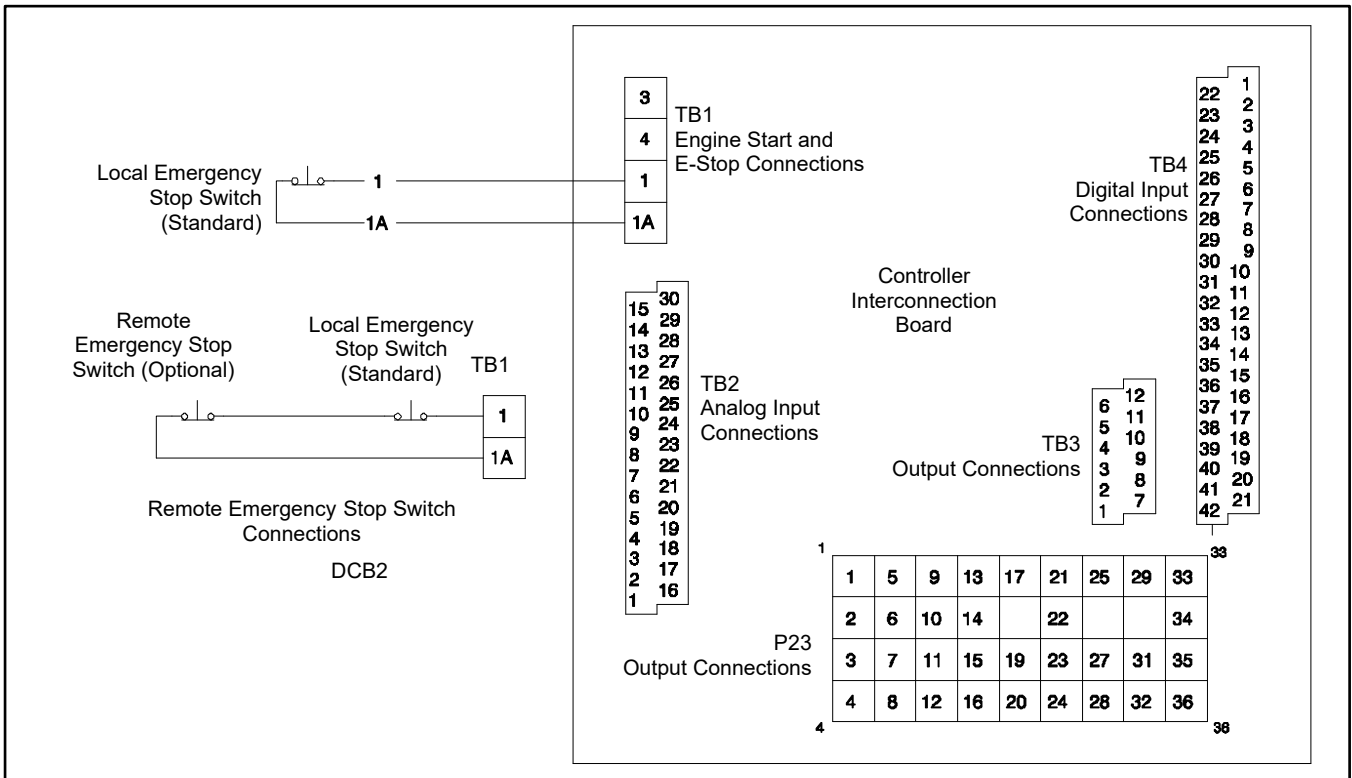

Figure 203 Remote Emergency Stop Kit Connections

12.1.9 Remote Reset Feature

The remote reset switch provides generator set resetting after a fault shutdown at a remote location. See the following figures for user-supplied switch connection.

Press and hold the switch for 2-3 seconds and release to reset the generator set controller.

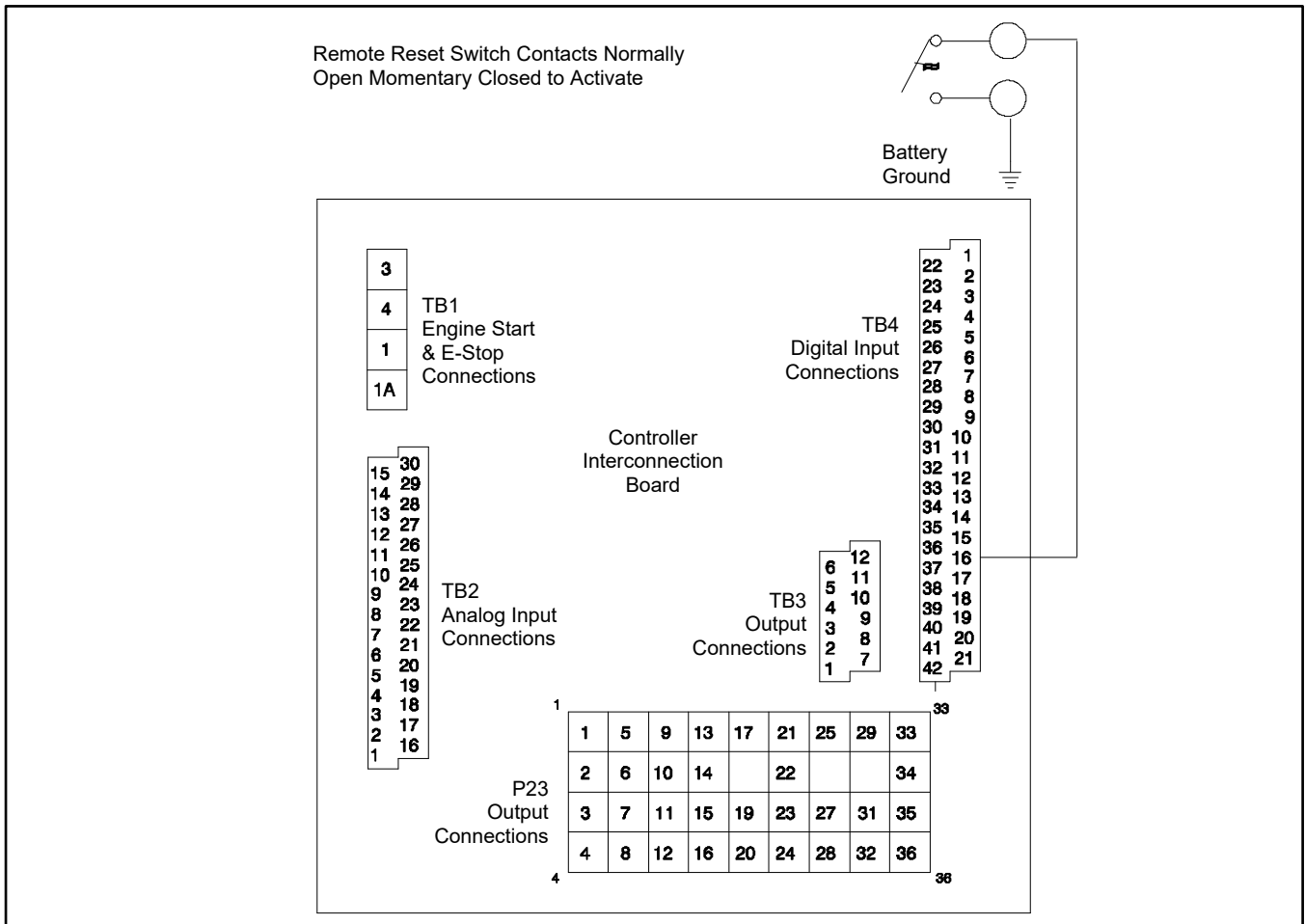

Figure 204 Remote Reset Switch Connections

Switch Rating	12 volts DC minimum, 0.5 amp minimum
Wiring Recommendation	
Gauge	Mm (ft.)
18-20	30.5 (100)
14	153 (500)
10	305 (1000)

Figure 205 Switch Rating & Wiring Recommendation

12.1.10 Remote Serial Annunciator (RSA III)

Refer to the RSA III installation instructions, TT-1625.

RSA III is an annunciator panel offered in several kit configurations to support power equipment. The RSA III is a remote serial annunciator that monitors the condition of the generator set and/or ATS from a remote location. The RSA III alerts the operator through visual and audible signals using LED indication and a horn. An alarm silence and lamp test switch are included.

The RSA III meets NFPA 110, Level 1 (2005) applications that require remote controls and alarms to be powered by a storage battery such as the engine starting battery. AC adaptor kit GM62466-KP1 is available when NFPA is not required.

A personal computer (PC) with SiteTech™ software is required to make the RSA III functional. SiteTech™ is available to authorized distributors and dealers.

An RSA III annunciator can be used for a single generator set or with a combination of a generator set and automatic transfer switch(es). In systems using more than a single RSA III, one must be designated as the master device to broadcast to additional RSA III annunciators, designated as slave devices. Up to five RSA III slave devices can be used with an RSA III master device. All RSA III annunciators are factory set as the master device, but can be changed to a slave device using a personal computer (PC) and SiteTech™ software that connects to the RSA III front panel via a universal serial bus (USB) connection.

For long distances and to reduce electrical noise, a lower baud rate, such as 19200, is recommended. See TT-1625 for more details.

Use SiteTech™ software to select that either the generator set controller or the transfer switch activates the EPS Supplying Load LED.

See the subsection, Accessory Connections, for terminal identifications.



Figure 206 Remote Serial Annunciator (RSA III)

Wiring

- For communication between the controller and RSA III master, see the figure below, P27 Connector on Master RSA III.
- For communication between RSA III Master and RSA III Slave, see the figure below, P27 Connection on RSA III Slave.
- Refer to the generator set wiring diagram for the RSA connections to the controller.
- If five or more devices are connected, place a terminating resistor on the last RSA III slave in the daisy chain connection.

Note:

When using RS-485 communication cable, connect the “shield” wire at either end but not at both ends.

P27 RS-485 Connections (from Controller to Master)	
P27-1	(-) Black (from controller)
P27-2	(+) White (from controller)
P27-3	Shield (from controller)
P27-4	(-) Black (to slave or terminating resistor)
P27-5	(+) White (to slave or terminating resistor)
P27-6	Shield (to slave or open)
Note: When using RS-485 communication cable, connect the "shield" wire at either end but not at both ends.	

Figure 207 P27 Connector on Master RSA III

Communication between RSA III Master and RSA III Slave. Select and connect the RS-485 wiring from the RSA III master to the RSA III slave(s) in a daisy chain wiring configuration. The figure below, "P27 Connection on RSA III Slave," shows the master/slave RS-485 connections and "RSA III Circuit Board GM86125 Connectors" shows the RSA III with P27 location.

- For communication connections, use #12-24 AWG shielded, twisted-pair communication cable. For indoor, non-plenum installations, Belden #9841 or equivalent cable is recommended.
- For outdoor or plenum installations, including those with buried cables and/or conduit, use outdoor-rated cable, Belden 3105DB or 3106DN or equivalent.

All wiring must comply with applicable national and local codes.

P27 RS-485 Connections (from Master to Slave)	
P27-1	(-) Black (from master or previous slave)
P27-2	(+) White (from master or previous slave)
P27-3	Shield (from master or previous slave)
P27-4	(-) Black (to next slave or terminating resistor)
P27-5	(+) White (to next slave or terminating resistor)
P27-6	Shield (to next slave or open)
Note: When using RS-485 communication cable, connect the "shield" wire at either end but not at both ends.	

Figure 208 P27 Connection on RSA III Slave

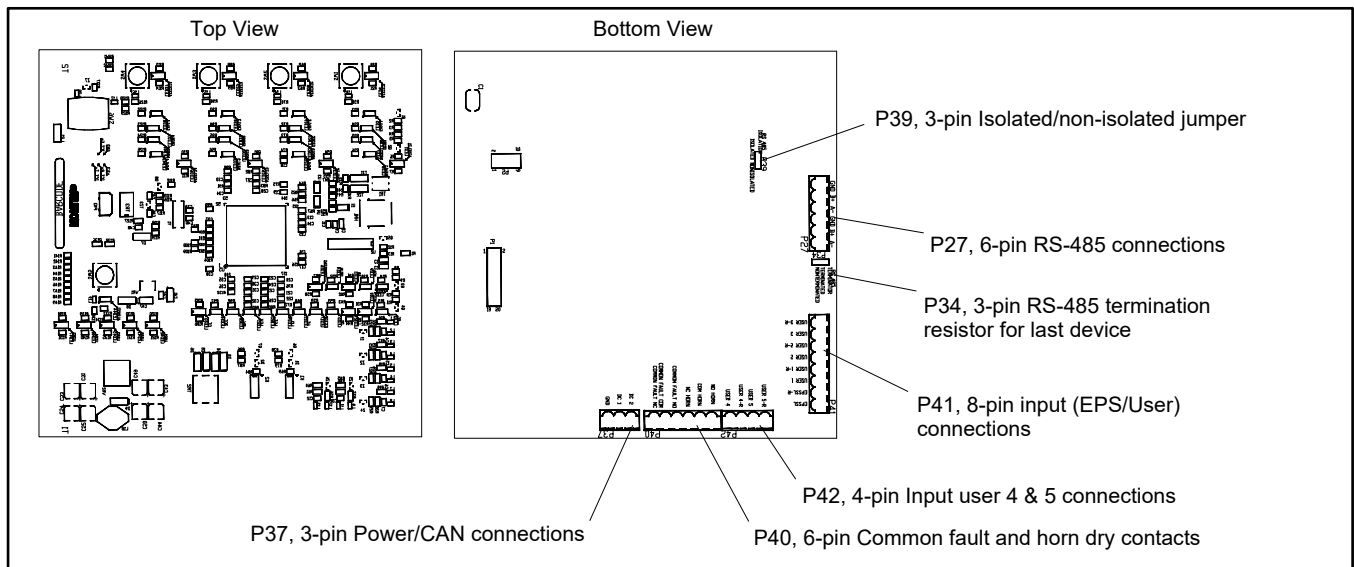

Figure 209 RSA III Circuit Board GM86125 Connectors

12.1.11 Shunt Trip Line Circuit Breaker

A shunt-trip line circuit breaker provides a 12- or 24-DC volt solenoid within the line circuit breaker case that can energize the trip mechanism. This feature allows the circuit breaker to be tripped by the common fault. Connection requires a shunt-trip wiring kit, which includes a shunt trip wiring harness and a dry contact kit.

The relay has contacts rated at 10 amps at 28 VDC or 120 VAC and is used to trigger the shunt-trip line circuit breaker kit.

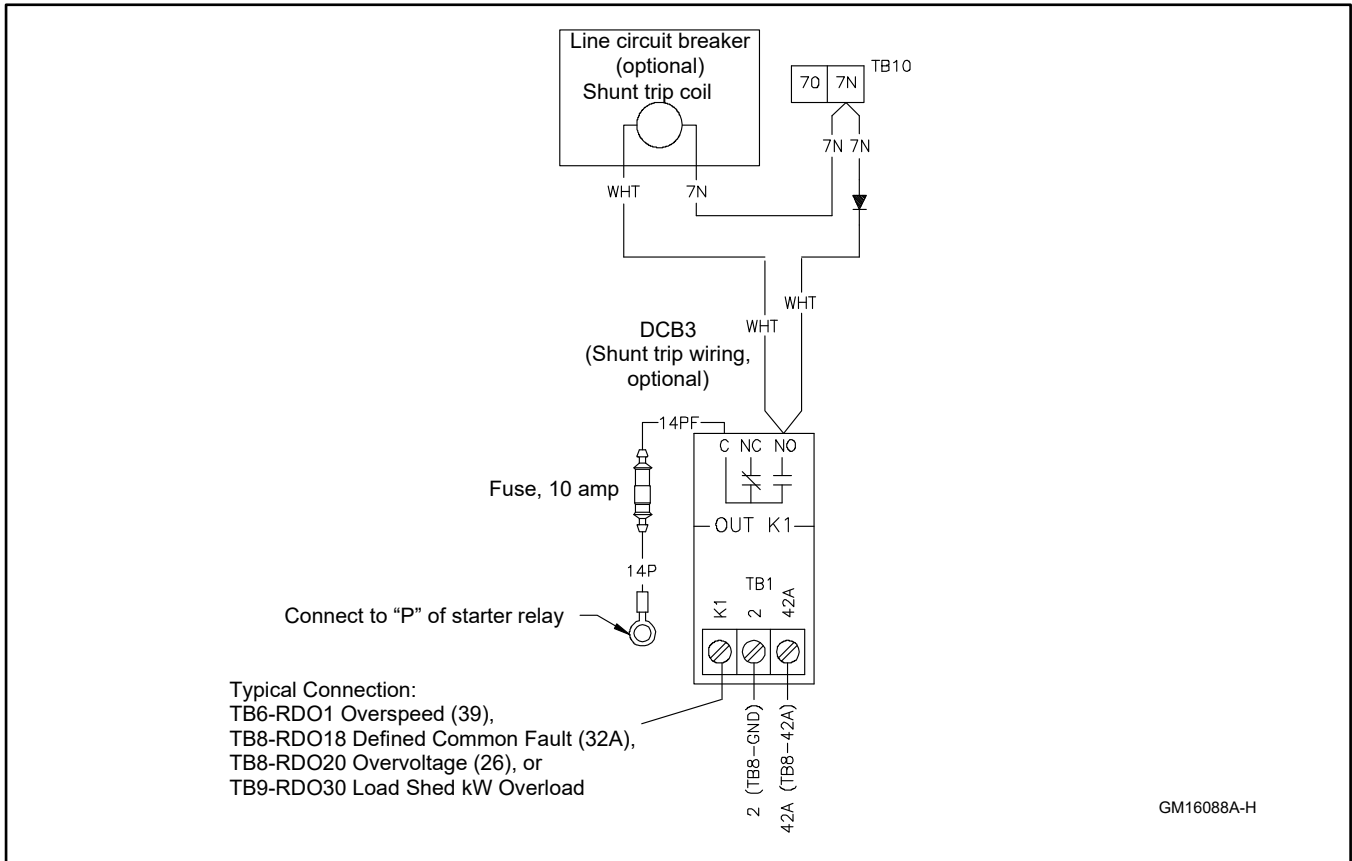

Figure 210 Shunt-Trip Line Circuit Breaker and Shunt-Trip Wiring Kit Connections

12.1.12 Single-Relay Dry Contact Kit

The single-relay dry contact kit provides normally open and normally closed contacts in a form C configuration to activate warning devices and other user-provided accessories allowing remote monitoring of the generator set. Typically, lamps, audible alarms, or other devices signal faults or status conditions. Connect any controller fault output to the single-relay dry contact kit.

A total of three dry contact kits may connect to a single controller output. See the figures below. See the following subsection, "Accessory Connections," for terminal identifications.

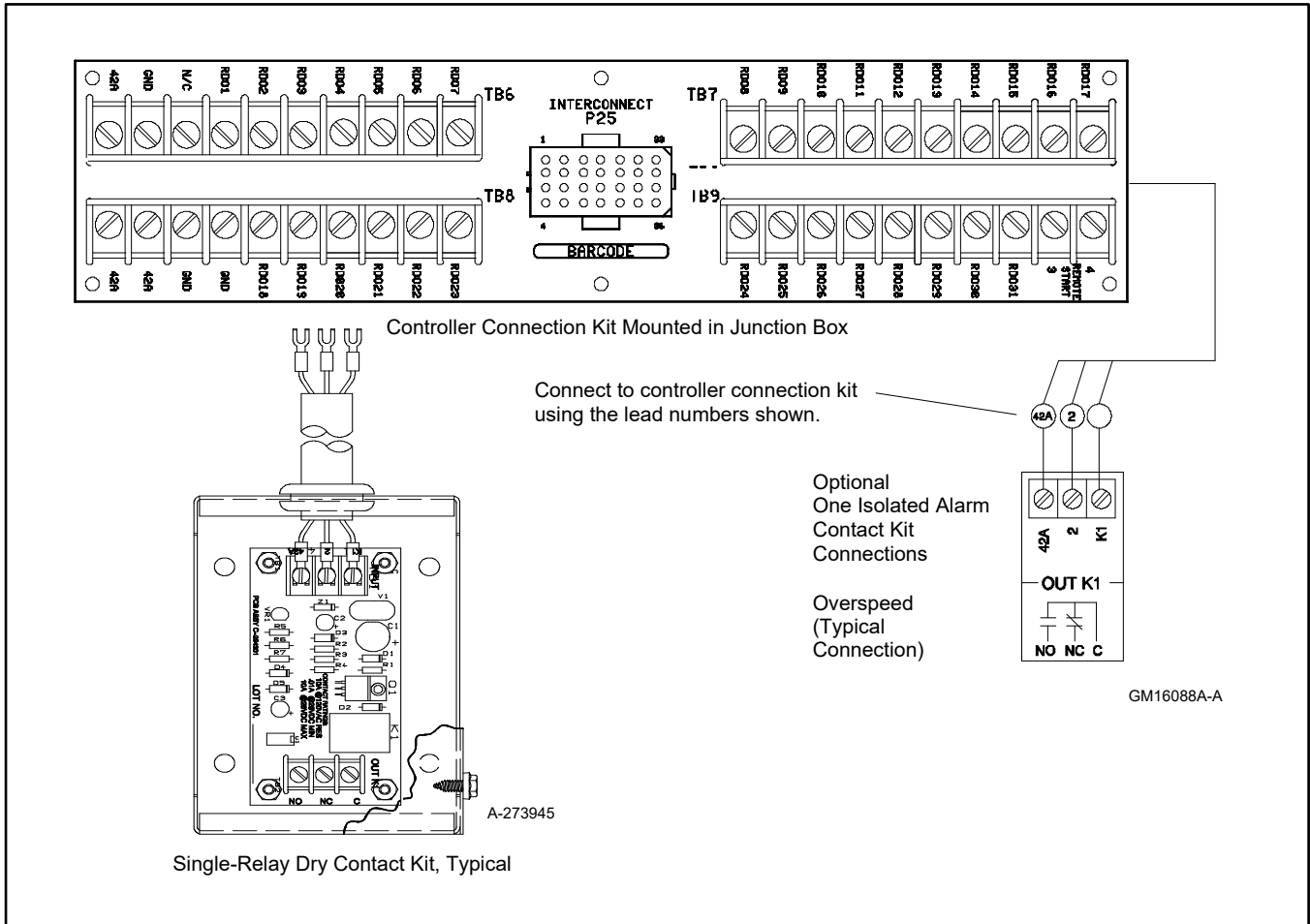

Figure 211 Single-Relay Dry Contact Kit Connections

12.1.13 Ten-Relay Dry Contact Kit

The ten-relay dry contact kit provides normally open and normally closed contacts in a form C configuration to activate warning devices and other user-provided accessories allowing remote monitoring of the generator set. Connect any controller fault output to the ten-relay dry contact kit. Typically, lamps, audible alarms, or other devices signal the fault conditions.

Refer to the figure, "Ten-Relay Dry Contact Kit" for an internal view of the contact kit. See the figure, "Ten-Relay Dry Contact Kit Connections," for electrical connections. See the following subsection, "Accessory Connections," for terminal identifications.

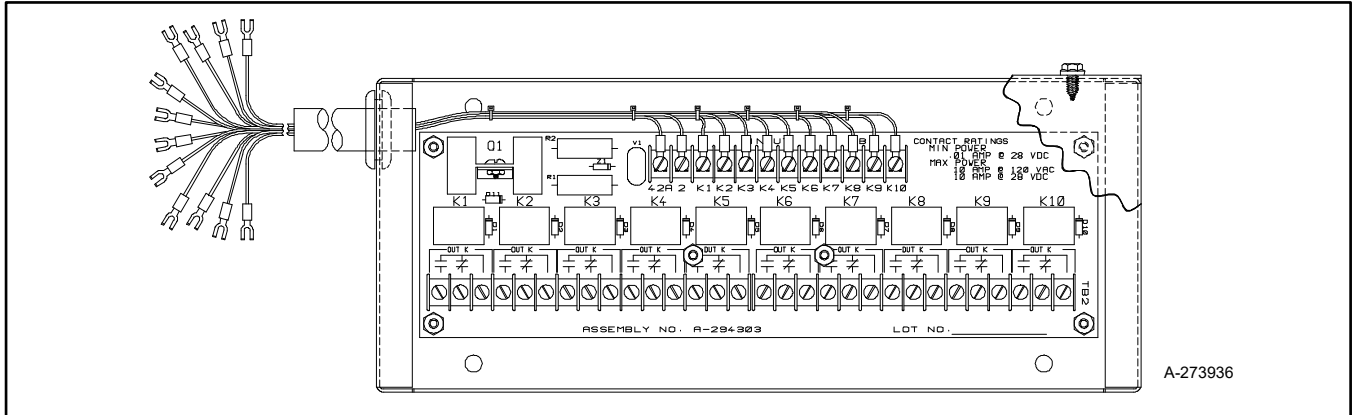

Figure 212 Ten-Relay Dry Contact Kit

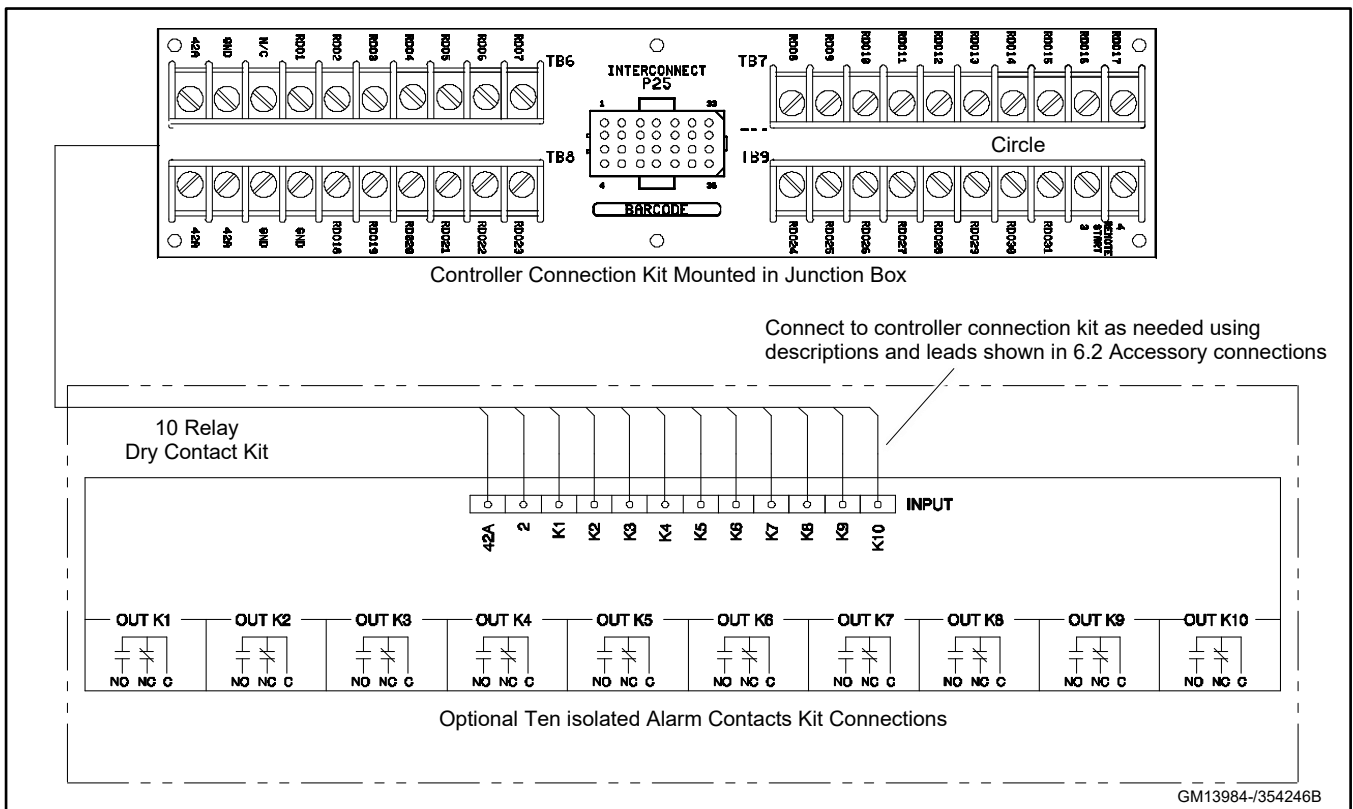
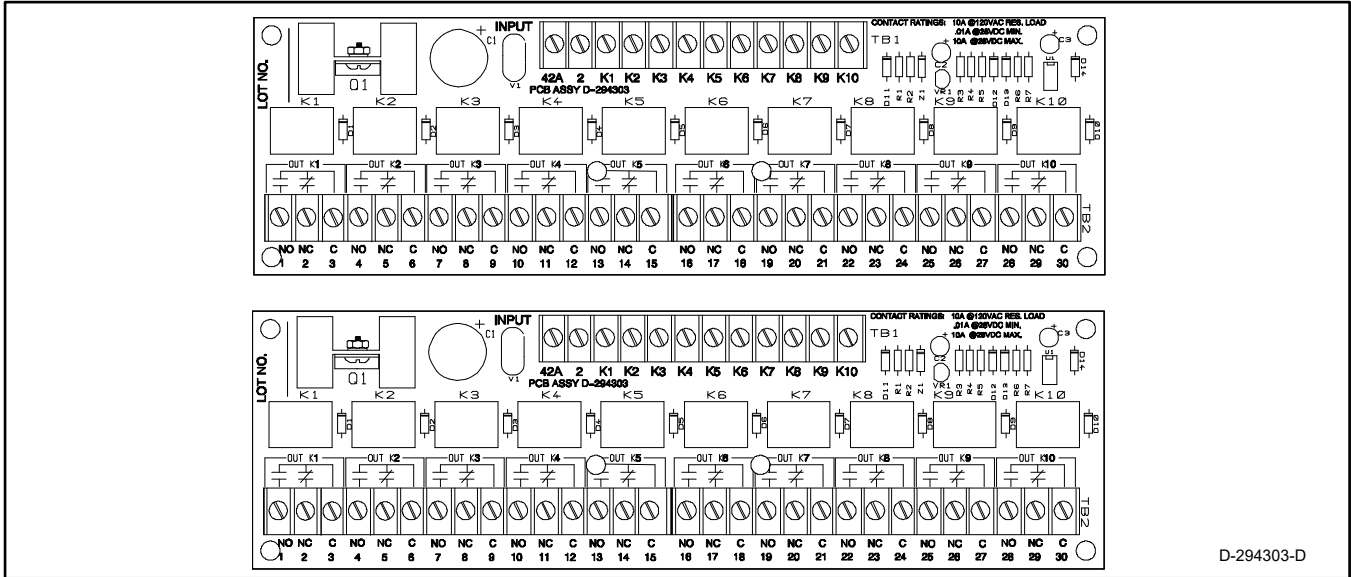

Figure 213 Ten-Relay Dry Contact Kit Connections

12.1.14 Twenty-Relay Dry Contact Kit

The twenty-relay dry contact kit provides normally open and normally closed contacts in a form C configuration to activate warning devices and other user-provided accessories allowing remote monitoring of the generator set. Typically, lamps, audible alarms, or other devices signal faults or status conditions. Connect any generator set fault output to the dry contact kit.

Refer to the figure below, "Twenty-Relay Dry Contact Kits" for an internal view of the contact kit. See the figure, "Twenty-Relay Dry Contact Relay Kit Connections" for electrical connections. See the following subsection, "Accessory Connections," for terminal identifications.



D-294303-D

Figure 214 Twenty-Relay Dry Contact Kits

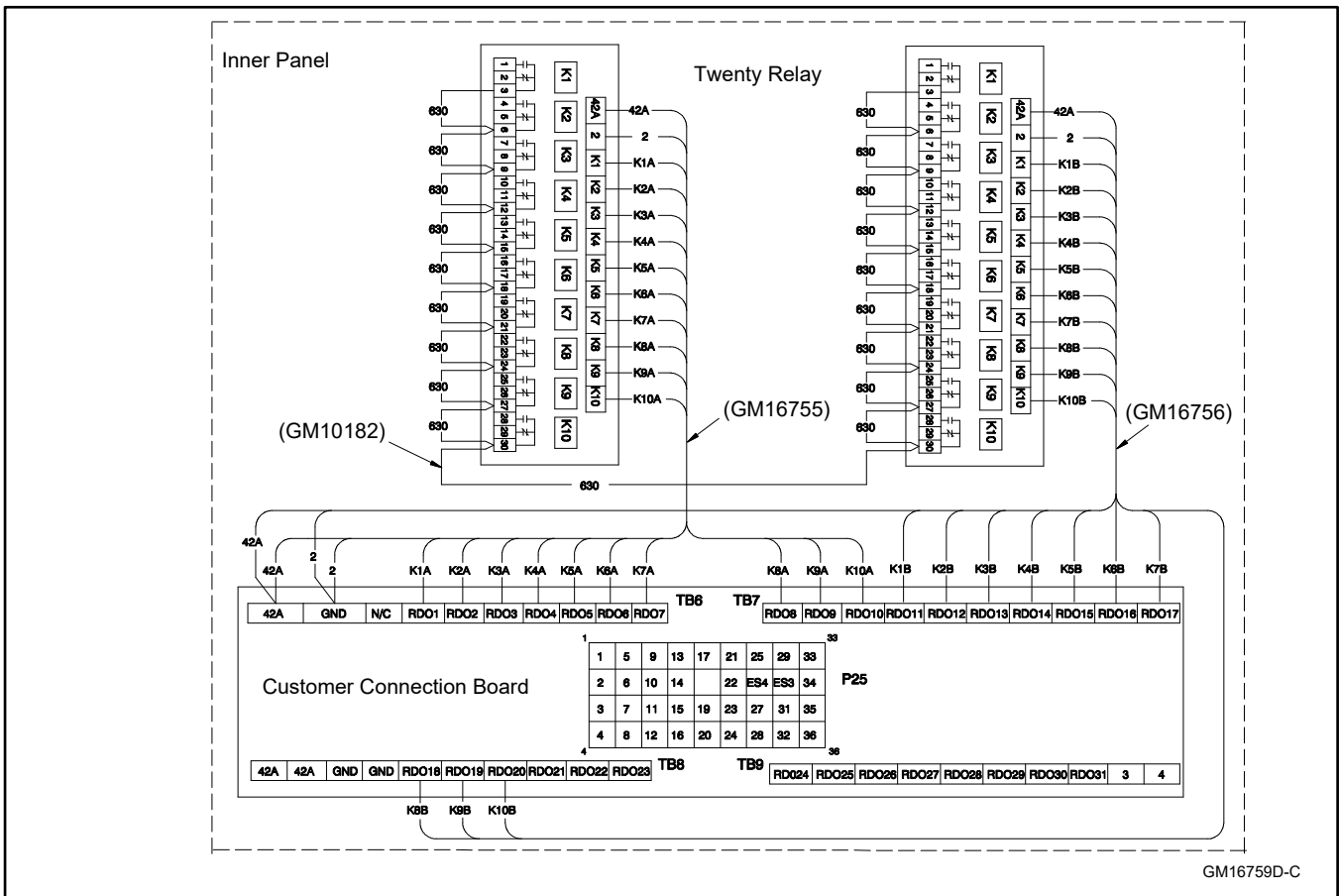

GM16759D-C

Figure 215 Twenty-Relay Dry Contact Relay Kit Connections

12.2 Accessory Connections

The controller contains circuit boards equipped with terminal strip(s) for use in connecting a controller connection kit. Do not connect accessories directly to the controller terminal strip(s). Connect accessories to either a controller connection kit or a dry contact kit. Connect the dry contact kit(s) to the controller connection kit. Connect alarms, battery chargers, remote switches, and other accessories to the dry contact kit relay(s).

For specific information on accessory connections, refer to the accessory wiring diagrams in the wiring diagram manual and the instruction sheet accompanying the kit.

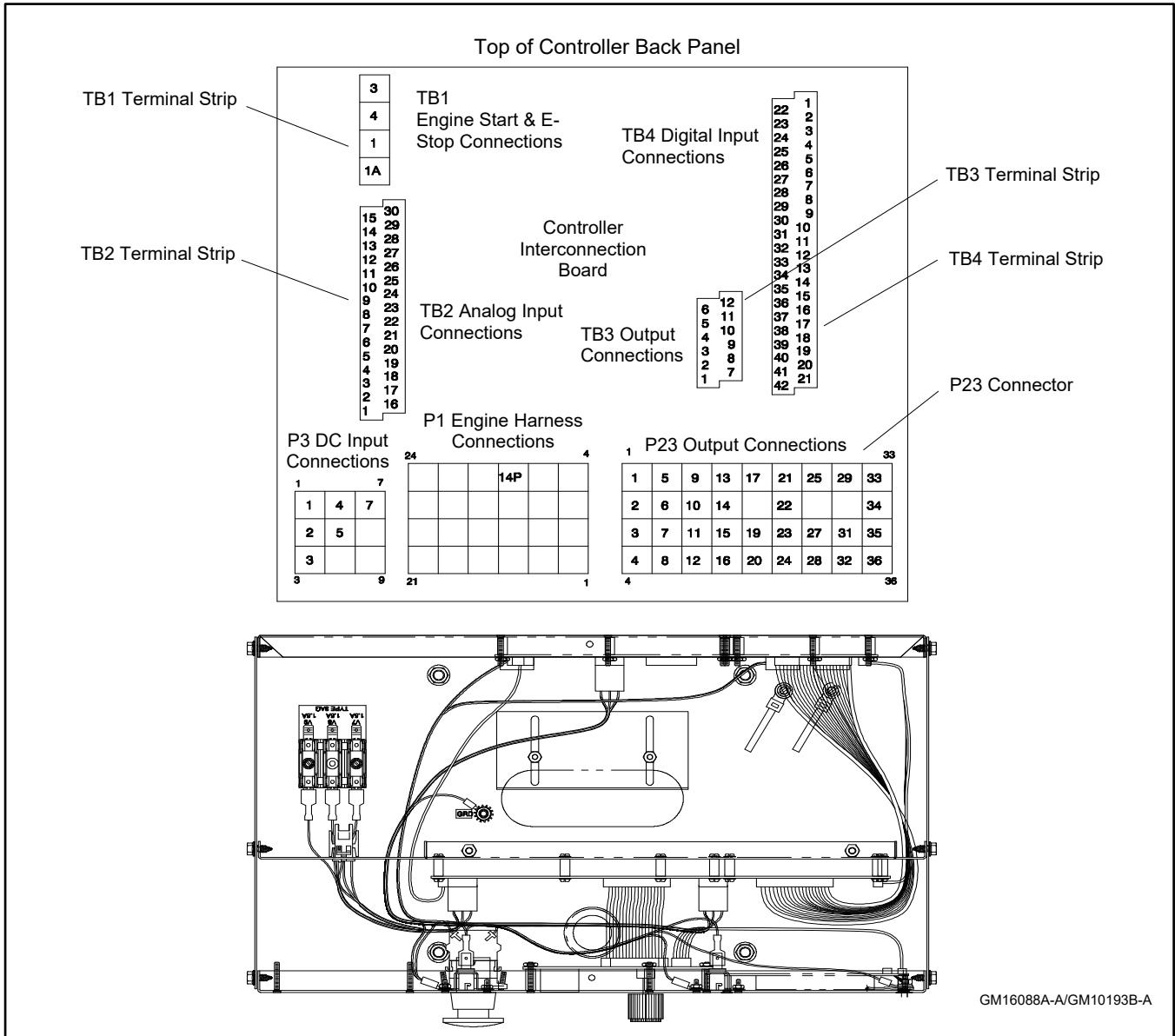
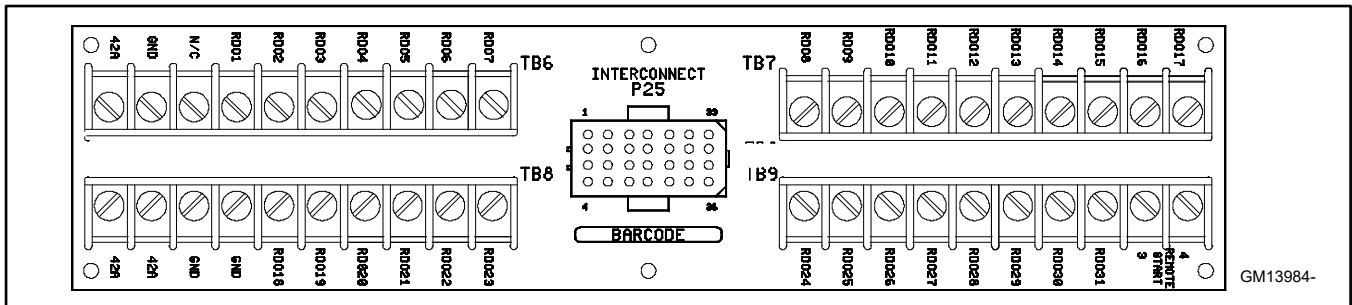

Figure 216 Terminal Strips on Controller Interconnection Circuit Board (Controller Back Panel Folded Down)

TB1 Terminal Strip—Engine Start and Emergency Stop Connections		TB4 Terminal Strip—Input Factory Connections	
Term.	Description	Term.	Description
1	Emergency stop ground	1	DCH1 Battery charger fault
1A	Emergency stop	2	DCH2 Low fuel
3	Remote start	3	DCH3 Low coolant temp. with ECM models or warning default with non-ECM models
4	Remote start	4	DCH4 Field overvoltage with M4/M5/M7 alternators or warning default with non-M4/M5/M7 alternators
TB2 Terminal Strip—Analog Input Connections		5	DCH5 Breaker Closed, Paralleling Applications
Term.	Description	6	DCH6 Enable Synch, Paralleling Applications
1	ACH1 (CTS) Signal (non-ECM including Waukesha)	7	DCH7 Warning
2	ACH1 (CTS) Supply (non-ECM including Waukesha)	8	DCH8 Warning
3	ACH2 (OPS) Signal (non-ECM including Waukesha)	9	DCH9 Warning
4	ACH2 (OPS) Supply (non-ECM including Waukesha)	10	DCH10 Warning
5	ACH3 Signal (air intake temp. for Waukesha)	11	DCH11 AFM Shutdown, Waukesha engine
6	ACH3 Supply (air intake temp. for Waukesha)	12	DCH12 Detonation Warning, Waukesha engine
7	ACH4 Signal (oil temp. for Waukesha)	13	DCH13 Detonation Shutdown, Waukesha engine
8	ACH4 Supply (oil temp. for Waukesha)	14	DCH14 Warning
9	ACH5 Signal	15	DCH15 Remote shutdown
10	ACH5 Supply	16	DCH16 Remote reset
11	ACH6 Signal	17	DCH17 VAR PF mode
12	ACH6 Supply (VSG for Volvo, GM, Doosan)	18	DCH18 Voltage lower
13	ACH7 Signal (optional analog voltage adjust signal)	19	DCH19 Voltage raise
14	ACH7 Supply	20	DCH20 Air damper
15	N/C	21	DCH21 Idle mode functional with ECM-equipped engines only
16	ACH1 (CTS) Return (non-ECM)	22	DCH1 Return
17	ACH1 (CTS) Shield ground (non-ECM)	23	DCH2 Return
18	ACH2 (OPS or OPS2) Return (non-ECM)	24	DCH3 Return
19	ACH2 (OPS) Shield ground (non-ECM)	25	DCH4 Return
20	ACH3 (IAT or OPS1) Return	26	DCH5 Return
21	ACH3 Shield ground	27	DCH6 Return
22	ACH4 (Oil Temp) Return	28	DCH7 Return
23	ACH4 Shield ground	29	DCH8 Return
24	ACH5 Return	30	DCH9 Return
25	ACH5 Shield ground	31	DCH10 Return
26	ACH6 Return	32	DCH11 Return
27	ACH6 Shield ground	33	DCH12 Return
28	ACH7 Return	34	DCH13 Return
29	ACH7 Shield ground	35	DCH14 Return
30	N/C	36	DCH16 Return
TB3 Terminal Strip—Accessory Power Output Connections		37	DCH16 Return
Term.	Description	38	DCH17 Return
1	+12 VDC (OEM use only)	39	DCH18 Return
2	+12 VDC (OEM use only)	40	DCH19 Return
3	+12 VDC (OEM use only)	41	DCH20 Return
4	Fused battery (+) (42A) (5 amp)	42	DCH21 Return
5	Fused battery (+) (42A) (5 amp)		
6	Fused battery (+) (42A) (5 amp)		
7	Battery (-)		
8	Battery (-)		
9	Battery (-)		
10	Battery (-)		
11	Battery (-)		
12	Panel lamp output		

Note: TB4-1 through TB4-21 are user definable with factory defaults listed. Terminals TB4-3, TB4-4, TB4-14, and TB4-21 have different functions depending upon the generator set configuration. See comments above. See Menu 9-Input Setup for changing inputs.

Figure 217 Controller Terminal Strip Identification



GM13984-

Figure 218 Terminal Strips TB6, TB7, TB8, and TB9 on the Controller Connection Kit in the Junction Box

TB6 Terminal Strip—RDOs 1-7		TB9 Terminal Strip—RDOs 24 – 31	
Term.	Description	Term.	Description
42A	Battery (+)	RDO24	Speed sensor fault
GND	Battery (-)	RDO25	Loss of AC sensing
N/C		RDO26	ECM loss of communication
RDO1	Overspeed (lead 39)	RDO27	Undervoltage
RDO2	Overcrank (lead 12)	RDO28	Overfrequency
RDO3	High coolant temperature shutdown (lead 36)	RDO29	Underfrequency
RDO4	Low oil pressure shutdown (lead 38)	RDO30	Load shed kW overload
RDO5	Low coolant temperature (lead 35)	RDO31	Load shed underfrequency
RDO6	High coolant temperature warning (lead 40)	3	Remote start
RDO7	Low oil pressure warning (lead 41)	4	Remote start
TB7 Terminal Strip—RDOs 8-17		Note: Lead numbers shown in parentheses are the factory default wire designations.	
Term.	Description	Note: RDO-1 though RDO-31 are user definable with the following factory defaults: emergency stop, high coolant temperature, low oil pressure, overcrank, and overspeed	
RDO8	Low fuel (lead 63)	*NFPA-110 common alarm faults include:	
RDO9	Master switch not in auto (lead 80)	Air damper indicator (RDO-23)	
RDO10	NFPA 110 common alarm (lead 32)*	Battery charger fault (RDO-11)	
RDO11	Battery charger fault (lead 61)	EPS supplying load (RDO-22)	
RDO12	Low battery voltage (lead 62)	High battery voltage (RDO-13)	
RDO13	High battery voltage	High coolant temperature warning (RDO-06)	
RDO14	Emergency stop (lead 48)	High coolant temperature shutdown (RDO-03)	
RDO15	Generator set running (lead 70R)	Low battery voltage (RDO-012)	
RDO16	Time delay engine cooldown (TDEC) (lead 70C)	Low coolant level (RDO-19)	
RDO17	System ready (lead 60)	Low coolant temperature warning (RDO-05)	
TB8 Terminal Strip—RDOs 18-23		Low fuel (level or pressure) (RDO-08)	
Term.	Description	Low oil pressure warning (RDO-07)	
42A	Battery (+)	Low oil pressure shutdown (RDO-04)	
42A	Battery (+)	Master switch not in auto (RDO-09)	
GND	Battery (-)	Overcrank (RDO-02)	
GND	Battery (-)	Overspeed (RDO-01)	
RDO18	Defined common fault (lead 32A)		
RDO19	Low coolant level		
RDO20	Overvoltage (lead 26)		
RDO21	Idle mode		
RDO22	EPS supplying load		
RDO23	Air damper indicator (lead 56)		

Figure 219 Controller (Customer) Connection Kit Terminal Strip Identification with Relay Driver Outputs (RDOs)





Notes

Section 13. Remote Adjustment/Control Systems

This section provides information about changes and adjustments when the system involves remote starting/control systems, voltage regulation, and paralleling generator set applications. Use the respective switchgear literature as supplied with the unit. Some of the items mentioned are available generator set accessories.

Before installing the generator set, provide for electrical connections through conduit to the transfer switch and other accessories for the generator set. Carefully install the selected generator set accessories. Route wiring to the generator set through flexible connections. Comply with all applicable codes when installing a wiring system.

See the previous section, Electrical System, for additional wiring information.

<p style="text-align: center;"> WARNING</p>	<p>Accidental starting. Can cause severe injury or death.</p>
<p style="text-align: center;">    </p>	<p>Disconnect the battery cables before working on the generator set. Remove the negative (-) lead first when disconnecting the battery. Reconnect the negative (-) lead last when reconnecting the battery.</p>

Disabling the generator set. Accidental starting can cause severe injury or death. Before working on the generator set or equipment connected to the set, disable the generator set as follows: (1) Move the generator set master switch to the OFF position. (2) Disconnect the power to the battery charger. (3) Remove the battery cables, negative (-) lead first. Reconnect the negative (-) lead last when reconnecting the battery. Follow these precautions to prevent starting of the generator set by an automatic transfer switch, remote start/stop switch, or engine start command from a remote computer.

(Decision-Maker® 3+ and 550 Controllers)

Disabling the generator set. Accidental starting can cause severe injury or death. Before working on the generator set or equipment connected to the set, disable the generator set as follows: (1) Press the generator set off/reset button to shut down the generator set. (2) Disconnect the power to the battery charger, if equipped. (3) Remove the battery cables, negative (-) lead first. Reconnect the negative (-) lead last when reconnecting the battery. Follow these precautions to prevent the starting of the generator set by the remote start/stop switch.



(APM402, APM603, RDC2, and Decision-Maker® 3000, 3500, and 6000 Controllers)

Disabling the generator set. Accidental starting can cause severe injury or death. Before working on the generator set or equipment connected to the set, disable the generator set as follows: (1) Shut down the generator set. (2) Place the controller in Out of Service mode. (3) Press the emergency stop button. (4) Disconnect the power to the battery charger, if equipped. (5) Remove the battery cables, negative (-) lead first. Reconnect the negative (-) lead last when reconnecting the battery. Follow these precautions to prevent the starting of the generator set by the remote start/stop switch.

(APM802 Controller)

Disabling the generator set. Accidental starting can cause severe injury or death. Before working on the generator set or equipment connected to the set, disable the generator set as follows: (1) If the controller is not already in the MAN (manual) mode, press the Controller Mode button and then press the MAN mode button. (2) If the generator set is running, press and hold the Manual-Stop button for at least 2 seconds to stop the generator set. (3) Press the Controller Mode button and then press the controller Off mode button. (4) Disconnect the power to the battery charger, if equipped. (5) Remove the battery cables, negative (-) lead first. Reconnect the negative (-) lead last when reconnecting the battery. Follow these precautions to prevent the starting of the generator set by the remote start/stop switch.

(Decision-Maker® 8000 Controller)

<p style="text-align: center;"> DANGER</p>	<p>Hazardous voltage. Moving parts. Will cause severe injury or death.</p>
<p style="text-align: center;">   </p>	<p>Operate the generator set only when all guards and electrical enclosures are in place.</p>

Short circuits. Hazardous voltage/current will cause severe injury or death. Short circuits can cause bodily injury and/or equipment damage. Do not contact electrical connections with tools or jewelry while making adjustments or repairs. Remove all jewelry before servicing the equipment.

13.1 Automatic Transfer Switches

A typical standby system has at least one automatic transfer switch connected to the generator set output to automatically transfer the electrical load to the generator set if the normal source fails. When normal power returns, the switch transfers the load back to the normal power source and then signals the generator set to stop.

The transfer switch uses a set of contacts to signal the engine/generator to start. When the normal source fails and the generator set master switch is in the AUTO position, the transfer switch contacts close to start the generator set.

The engine start terminals are usually located near the transfer switch contactor with an engine start decal identifying the terminals. Refer to the transfer switch decal, operation/installation manual, or wiring diagram manual to identify the engine start terminals prior to making connections.

Make connections to the transfer switch engine-start terminals and remote manual engine-start switch using wire run through conduit. Use separate conduits for engine-start leads, generator set load cables, battery charger leads, and remote annunciator wiring.

Use a minimum of 13 mm (0.5 in.) spacing between the conduit bushing and any uninsulated live parts in the ATS enclosure. All conduit openings in the ATS enclosure must be made such that no metal particles including drill chips contaminate the components in the ATS enclosure.

13.2 APM402 and Decision-Maker 3000 Controller Voltage Regulator

The controller has a voltage regulation function that is internal to the processor.

See the APM402/Decision-Maker® 3000 Controller and SiteTech™ Operation Manuals for further details regarding voltage adjustment setup.

13.3 APM603 Controller Voltage Regulator

The controller has a voltage regulation function that is internal to the processor.

See the APM603 Controller and SiteTech™ Operation Manuals for further details regarding voltage adjustment setup.

13.4 APM802 Controller Voltage Regulator

The generator set uses either a DER2 or D510C voltage regulator depending on the alternator.

See the APM802 Controller Operation Manual and Alternator Service and Maintenance Manual for further details regarding voltage adjustment.

13.5 Decision-Maker 550 Controller, Voltage Regulator and Paralleling Applications

The controller has a voltage regulation function that is internal to the processor.

See the Decision-Maker® 550 Controller Operation Manual for further details regarding voltage adjustment and paralleling operation setup.

13.6 Decision-Maker 3500 Controller Voltage Regulator

The controller has a voltage regulation function that is internal to the processor.

See the Decision-Maker® 3500 Controller and SiteTech™ Operation Manuals for further details regarding voltage adjustment setup.

13.7 Decision-Maker 6000 Controller Voltage Regulator and Paralleling Applications

The controller has a voltage regulation function that is internal to the processor.

See the Decision-Maker® 6000 Controller, Decision-Maker® Paralleling (DPS), and SiteTech™ Operation Manuals for further details regarding voltage adjustment and paralleling operation setup.

13.8 Decision-Maker 8000 Controller Voltage Regulator and Paralleling Applications

The generator set uses a Marathon® DVR® 2000EC voltage regulator.

See the Decision-Maker® 8000 Controller Operation Manual and TP-5579 Operation Manual, DVR® 2000 Voltage Regulator for further details regarding voltage adjustment and paralleling operation setup.

13.9 Remote Speed Adjustment

This kit provides remote engine speed adjustments with an approximate range of $\pm 5\%$ at 1800 rpm. This kit requires a generator set with an electronic governor. See Figure 220 and Figure 221.

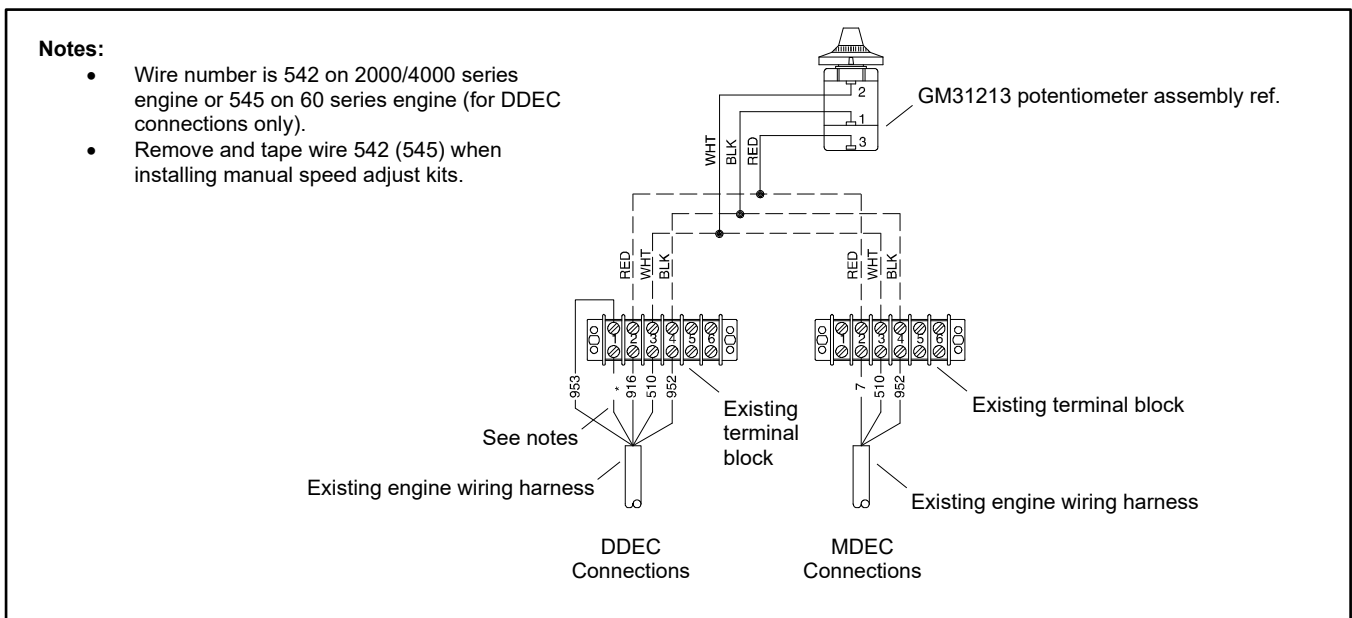

Figure 220 Remote Speed Adjusting Control Wiring Diagram

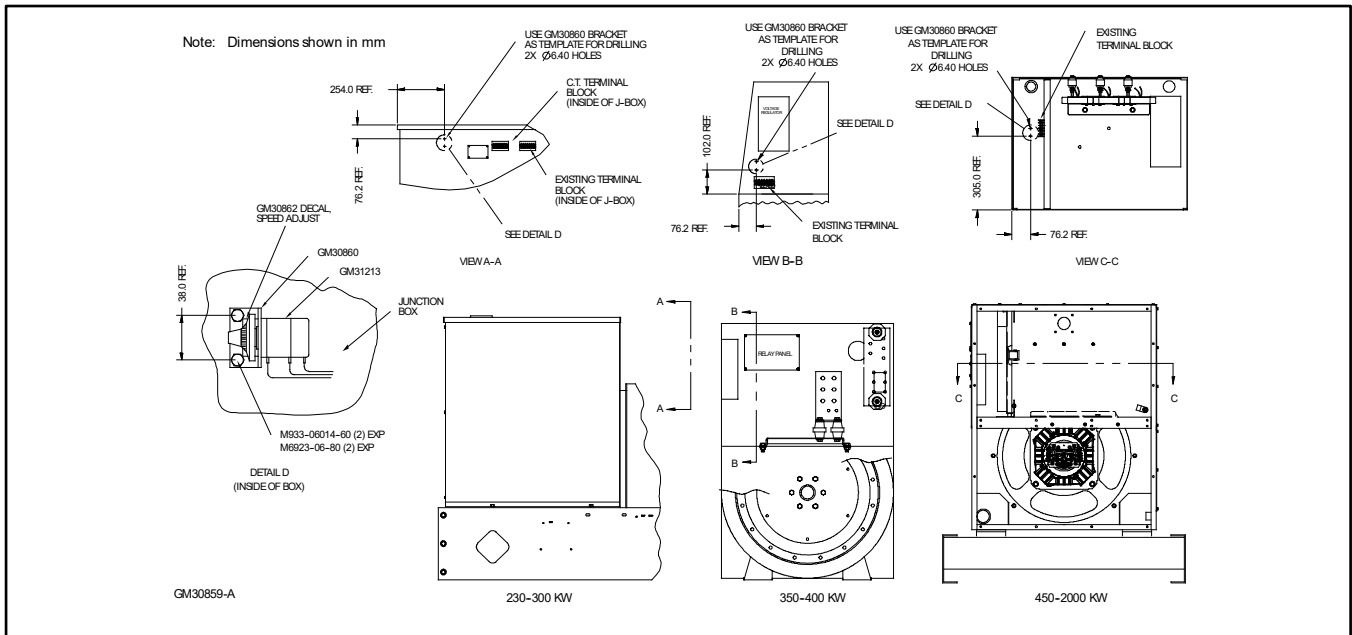

Figure 221 Remote Speed Potentiometer Installation

To program the 550 controller, MDEC-equipped DDC/MTU engines only, use the following instructions. See the 550 controller operation manual for further information, if necessary.

1. Go to Menu 14 - PROGRAMMING MODE to enable LOCAL programming.
2. Go to Menu 7 - GENERATOR SYSTEM.
3. Press MENU Down ↓ Key to access ENABLE VSG (variable governor speed) data.
4. Press the YES Key.
5. Press the ENTER ← Key to confirm entry.
6. Verify ENABLE VSG code YES appears on the display.
7. Go to Menu 14 - PROGRAMMING MODE to change to programming mode OFF.

13.10 Remote Voltage Adjustment

This kit provides the ability to fine adjust the generator output voltage from a remote location. The maximum recommended wire length from the potentiometer to the generator set is 15 ft. (4.6 m); 18-gauge twisted pair wire is recommended. See Figure 222 and Figure 223.

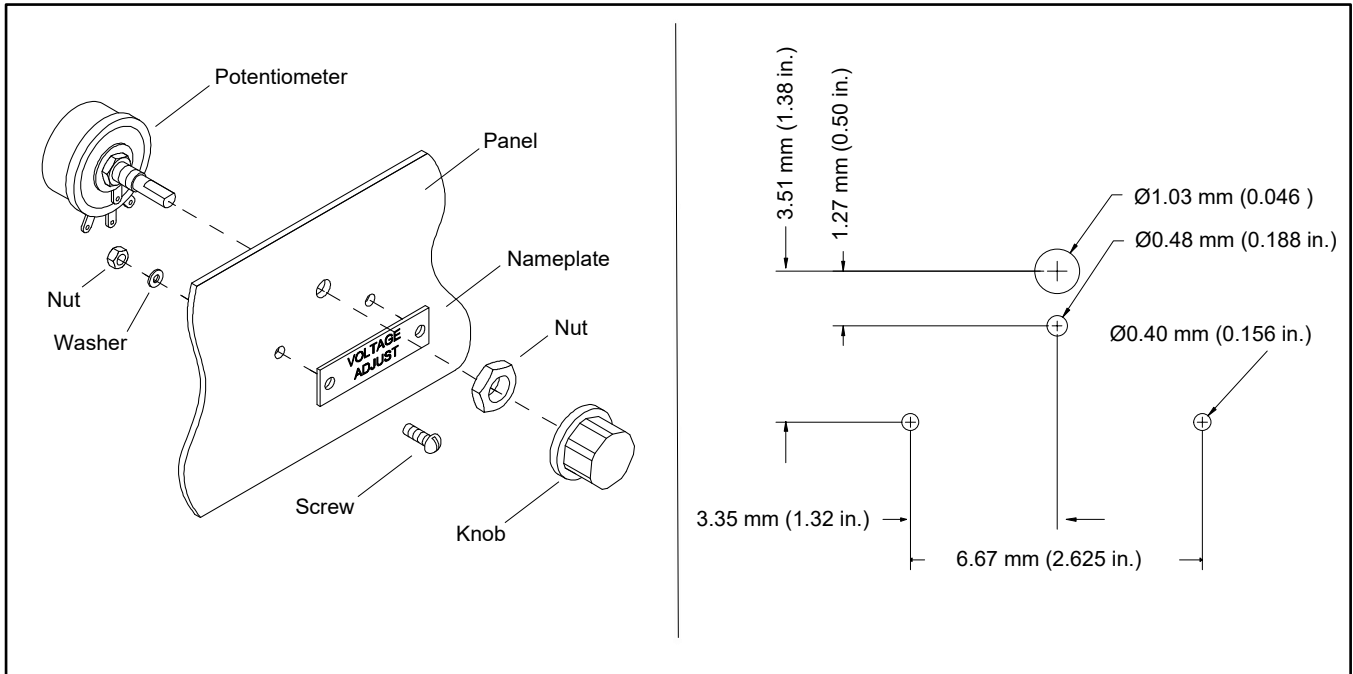

Figure 222 Potentiometer Installation

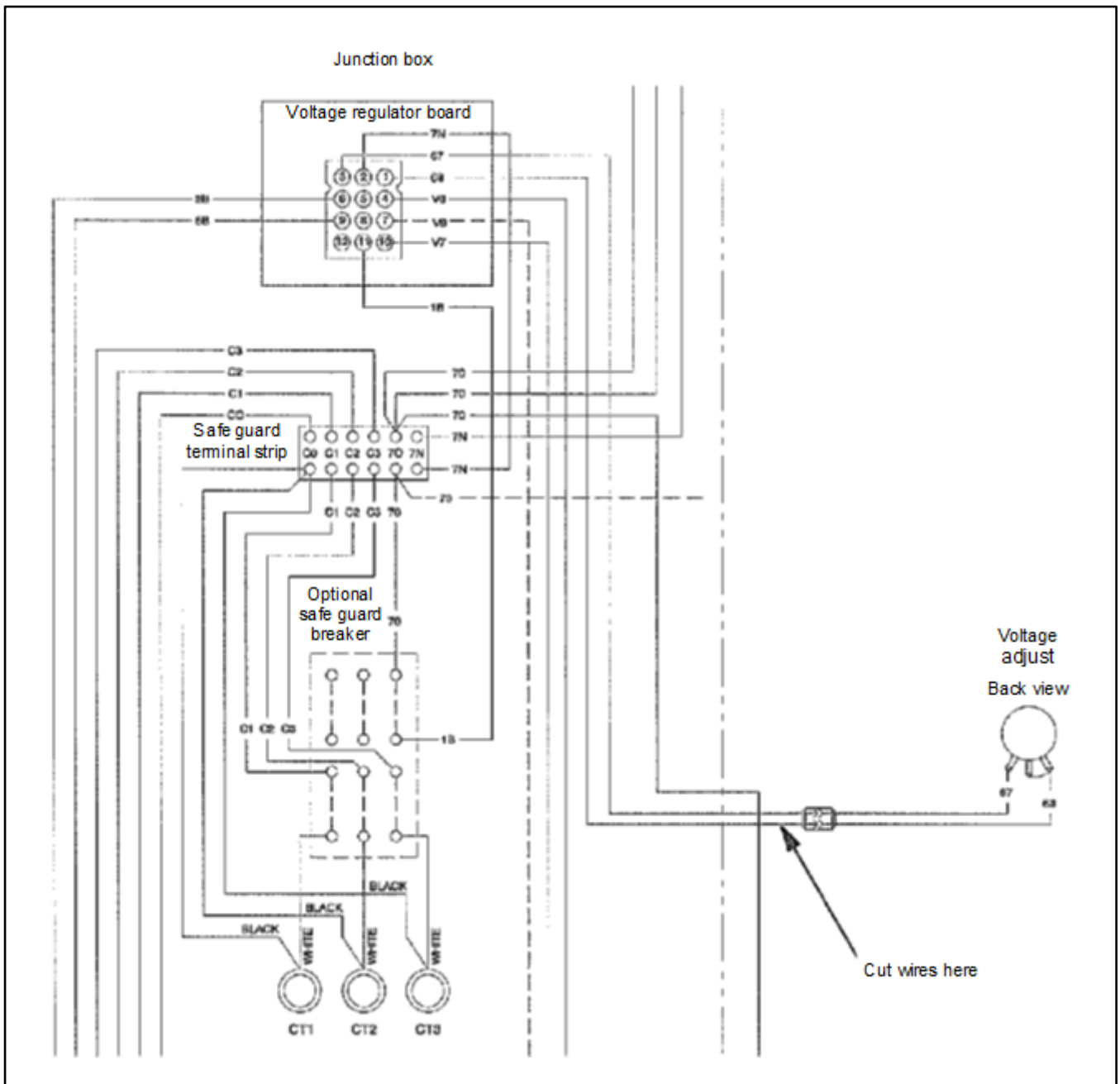

Figure 223 Disconnection of Controller Voltage Adjusting Potentiometer

13.11 Remote Wiring

Figure 224 is the accessory interconnection diagram showing the remote wiring for the 550 controller.

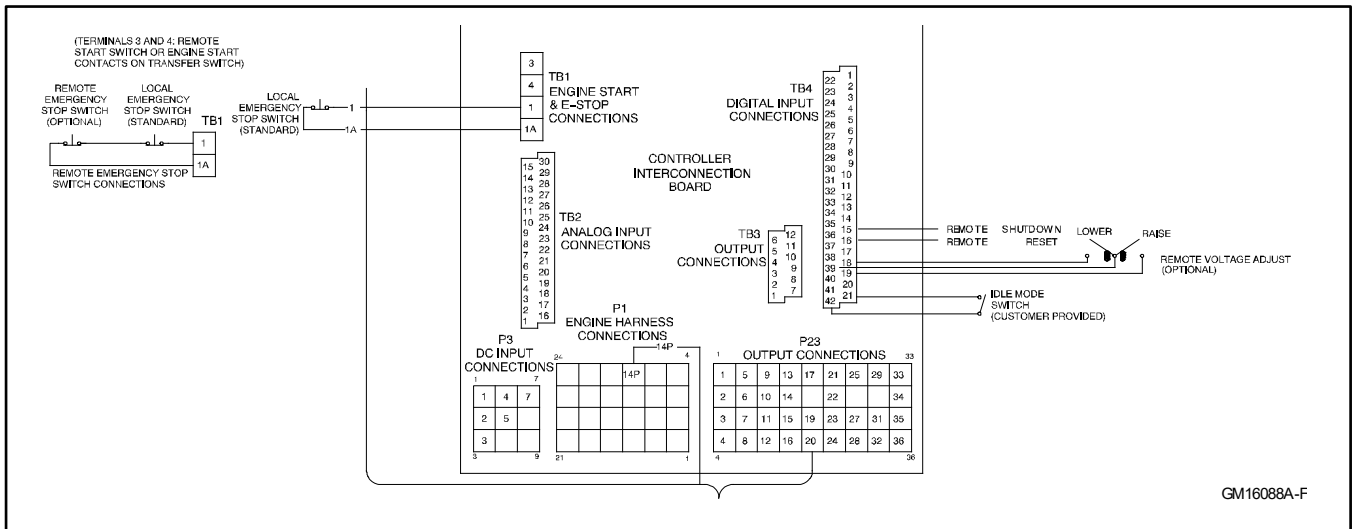

Figure 224 550 Controller Remote Wiring

13.12 Voltage Regulator DVR 2000 / Remote Voltage Regulator Kit, 350 kW and Above

The DVR[®] 2000E is used with nonparalleling applications and the DVR[®] 2000EC is used when paralleling is required.

If the voltage configuration is changed, make adjustments to the DVR[®] 2000 voltage regulator at the voltage regulator. Remove the junction box cover to adjust the DVR[®] 2000 voltage regulator. See Figure 225, Figure 226, and TP-5579 Operation Manual, DVR[®] 2000 Voltage Regulator for more information.

Use Figure 226 for installation and troubleshooting of the electrical wiring system

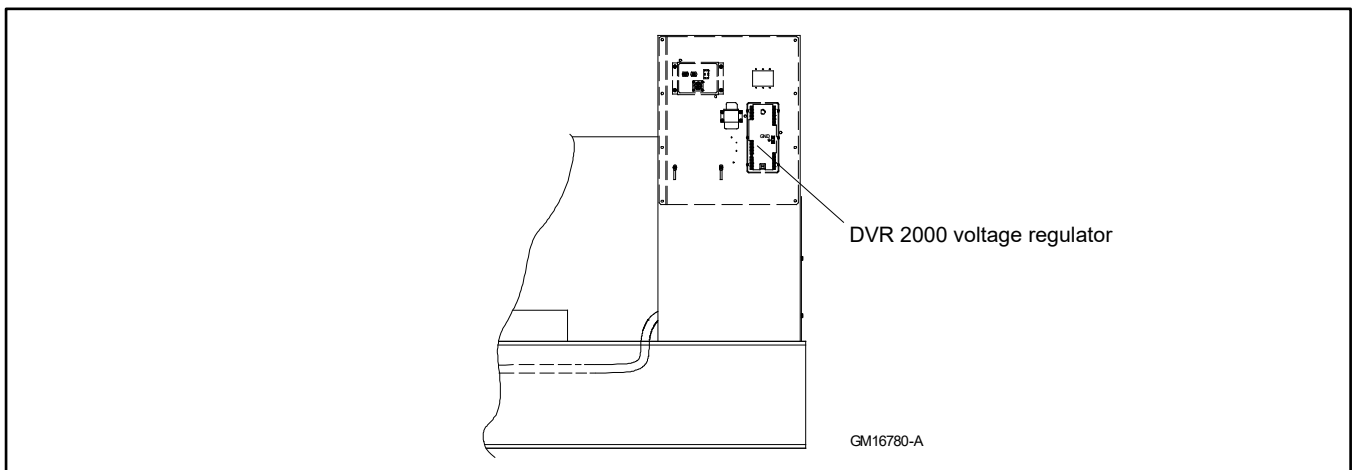

Figure 225 DVR[®] 2000 Voltage Regulator Mounting Location

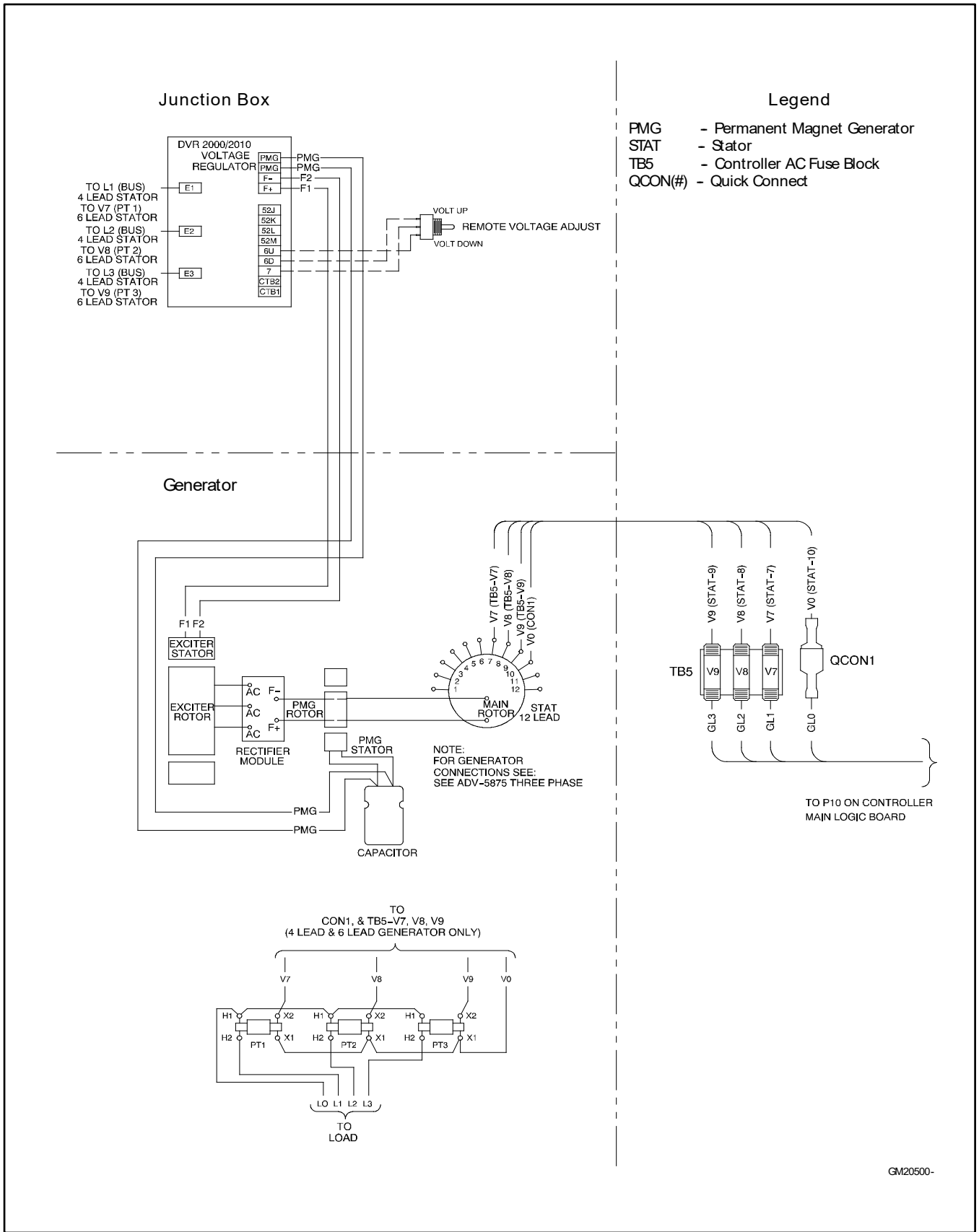

Figure 226 DVR[®] 2000 Voltage Regulator/Alternator Interconnection Wiring Diagram

Appendix A. Abbreviations

A, amp	ampere	blk. htr.	block heater	DAC	digital to analog converter
ABDC	after bottom dead center	BMEP	brake mean effective pressure	dB	decibel
AC	alternating current	bps	bits per second	dB(A)	decibel (A weighted)
A/D	analog to digital	br.	Brass	DC	direct current
ADC	advanced digital control; analog to digital converter	BTDC	before top dead center	DCR	direct current resistance
adj.	adjust, adjustment	Btu	British thermal unit	DEF	diesel exhaust fluid
ADV	advertising dimensional drawing	Btu/min.	British thermal units per minute	deg., °	degree
AGM	absorbent glass mat	C	Celsius, centigrade	dept.	department
Ah	amp-hour	cal.	Calorie	dia.	Diameter
AHWT	anticipatory high water temperature	CAN	controller area network	DI/EO	dual inlet/end outlet
AISI	American Iron and Steel Institute	CARB	California Air Resources Board	DIN	Deutsches Institut für Normung e. V. (also Deutsche Industrie Normenausschuss)
ALOP	anticipatory low oil pressure	CAT5	Category 5 (network cable)	DIP	dual inline package
alt.	alternator	CB	circuit breaker	DPDT	double-pole, double-throw
Al	aluminum	CC	crank cycle	DPST	double-pole, single-throw
ANSI	American National Standards Institute (formerly American Standards Association, ASA)	cc	cubic centimeter	DS	disconnect switch
AO	anticipatory only	CCA	cold cranking amps	DVR	digital voltage regulator
APDC	Air Pollution Control District	ccw.	Counterclockwise	E2PROM, EEPROM	electrically-erasable programmable read-only memory
API	American Petroleum Institute	CEC	Canadian Electrical Code	E, emer.	emergency (power source)
approx.	approximate, approximately	cert.	certificate, certification, certified	EATS	Exhaust Aftertreatment System
APU	Auxiliary Power Unit	cfh	cubic feet per hour	ECM	electronic control module, engine control module
AQMD	Air Quality Management District	cfm	cubic feet per minute	EDI	electronic data interchange
AR	as required, as requested	CG	center of gravity	EFR	emergency frequency relay
AS	as supplied, as stated, as suggested	CID	cubic inch displacement	e.g.	for example (exempli gratia)
ASE	American Society of Engineers	CL	centerline	EG	electronic governor
ASME	American Society of Mechanical Engineers	cm	centimeter	EGSA	Electrical Generating Systems Association
assy.	Assembly	CMOS	complementary metal oxide substrate (semiconductor)	EIA	Electronic Industries Association
ASTM	American Society for Testing Materials	com	communications (port)	EI/EO	end inlet/end outlet
ATDC	after top dead center	coml	commercial	EMI	electromagnetic interference
ATS	automatic transfer switch	Coml/Rec	Commercial/Recreational	emiss.	Emission
auto.	Automatic	conn.	Connection	eng.	Engine
aux.	auxiliary	cont.	continued	EPA	Environmental Protection Agency
avg.	average	CPVC	chlorinated polyvinyl chloride	EPS	emergency power system
AVR	automatic voltage regulator	crit.	Critical	ER	emergency relay
AWG	American Wire Gauge	CRM	Common Rail Manifold	ES	engineering special, engineered special
AWM	appliance wiring material	CSA	Canadian Standards Association		
bat.	Battery	CT	current transformer	ESD	electrostatic discharge
BBDC	before bottom dead center	Cu	copper	est.	estimated
BC	battery charger, battery charging	cUL	Canadian Underwriter's Laboratories	E-Stop	emergency stop
BCA	battery charging alternator	cu. in.	cubic inch	etc.	et cetera (and so forth)
BCI	Battery Council International	cw.	Clockwise	exh.	exhaust
BDC	before dead center	CWC	city water-cooled	ext.	external
BHP	brake horsepower	cyl.	Cylinder	F	Fahrenheit, female
blk.	black (paint color), block (engine)	D/A	digital to analog	FDS	Fluid Dosing System

FHM	flat head machine (screw)	in.	inch	Lpm	liters per minute
fl. oz.	fluid ounce	in. H ₂ O	inches of water	LOP	low oil pressure
flex.	flexible	in. Hg	inches of mercury	LP	liquefied petroleum
freq.	frequency	in. Lb.	inch pounds	LPG	liquefied petroleum gas
FS	full scale	Inc.	incorporated	LS	left side
ft.	foot, feet	ind.	Industrial	L _{wa}	sound power level, A weighted
ft. lb.	foot pounds (torque)	int.	internal	LWL	low water level
ft./min.	feet per minute	int./ext.	internal/external	LWT	low water temperature
ftp	file transfer protocol	I/O	input/output	m	meter, milli (1/1000)
g	gram	IP	internet protocol	M	mega (10 ⁶ when used with SI units), male
ga.	gauge (meters, wire size)	ISO	International Organization for Standardization	m ³	cubic meter
gal.	gallon	J	joule	m ³ /hr.	cubic meters per hour
gen.	generator	JIS	Japanese Industry Standard	m ³ /min.	cubic meters per minute
genset	generator set	k	kilo (1000)	mA	milliampere
GFI	ground fault interrupter	K	kelvin	man.	manual
GND, ⊕	ground	kA	kiloampere	max.	maximum
gov.	governor	KB	kilobyte (2 ¹⁰ bytes)	MB	megabyte (2 ²⁰ bytes)
gph	gallons per hour	KBus	Communication protocol	MCCB	molded-case circuit breaker
gpm	gallons per minute	kg	kilogram	MCM	one thousand circular mils
gr.	grade, gross	kg/cm ²	kilograms per square centimeter	meggar	megohmmeter
GRD	equipment ground	kgm	kilogram-meter	MHz	megahertz
gr. wt.	gross weight	kg/m ³	kilograms per cubic meter	mi.	mile
H x W x D	height by width by depth	kHz	kilohertz	mil	one one-thousandth of an inch
HC	hex cap	kJ	kilojoule	min.	minimum, minute
HCHT	high cylinder head temperature	km	kilometer	misc.	miscellaneous
HD	heavy duty	kOhm, kΩ	kilo-ohm	MJ	megajoule
HET	high exhaust temp., high engine temp.	kPa	kilopascal	mJ	millijoule
hex	hexagon	kph	kilometers per hour	mm	millimeter
Hg	mercury (element)	kV	kilovolt	mOhm, mΩ	milliohm
HH	hex head	kVA	kilovolt ampere	MOhm, MΩ	megohm
HHC	hex head cap	kVAR	kilovolt ampere reactive	MOV	metal oxide varistor
HP	horsepower	kW	kilowatt	MPa	megapascal
hr.	hour	kWh	kilowatt-hour	mpg	miles per gallon
HS	heat shrink	kWm	kilowatt mechanical	mph	miles per hour
hsg.	Housing	kWth	kilowatt-thermal	MS	military standard
HVAC	heating, ventilation, and air conditioning	L	liter	ms	millisecond
HWT	high water temperature	LAN	local area network	m/sec.	meters per second
Hz	hertz (cycles per second)	L x W x H	length by width by height	mtg.	mounting
IBC	International Building Code	lb.	pound, pounds	MTU	Motoren-und Turbinen-Union
IC	integrated circuit	lbm/ft ³	pounds mass per cubic feet	MW	megawatt
ID	inside diameter, identification	LCB	line circuit breaker	mW	milliwatt
IEC	International Electrotechnical Commission	LCD	liquid crystal display	μF	microfarad
IEEE	Institute of Electrical and Electronics Engineers	LED	light emitting diode	μF	microfarad
IMS	improved motor starting	Lph	liters per hour		

N, norm.	normal (power source)	PMG	permanent magnet generator	SCR	silicon controlled rectifier (electrical), selective catalytic reduction (exhaust emissions)
NA	not available, not applicable	pot	potentiometer, potential	s, sec.	second
nat. gas	natural gas	ppm	parts per million	SI	<i>Systeme international d'unites</i> , International System of Units
NBS	National Bureau of Standards	PROM	programmable read-only memory	SI/EO	side in/end out
NC	normally closed	psi	pounds per square inch	sil.	Silencer
NEC	National Electrical Code	psig	pounds per square inch gauge	SMTP	simple mail transfer protocol
NEMA	National Electrical Manufacturers Association	pt.	pint	SN	serial number
NiCd	nickel cadmium	PTC	positive temperature coefficient	SNMP	simple network management protocol
NFPA	National Fire Protection Association	PTO	power takeoff	SPDT	single-pole, double-throw
Nm	newton meter	PVC	polyvinyl chloride	SPST	single-pole, single-throw
NO	normally open	PVC	polyvinyl chloride	spec	specification
no., nos.	number, numbers	PWM	pulse width modulated, pulse width modulation	specs	specification(s)
NPS	National Pipe, Straight	qt.	quart, quarts	sq.	square
NPSC	National Pipe, Straight-coupling	qty.	quantity	sq. cm	square centimeter
NPT	National Standard taper pipe thread per general use	R	replacement (emergency) power source	sq. in.	square inch
NPTF	National Pipe, Taper-Fine	rad.	radiator, radius	SMS	short message service
NR	not required, normal relay	RAM	random access memory	SS	stainless steel
Ns	nanosecond	RDO	relay driver output	std.	standard
OC	overcrank	ref.	reference	stl.	Steel
OD	outside diameter	rem.	Remote	tach.	Tachometer
OEM	original equipment manufacturer	Res/Com	Residential/Commercial	TB	terminal block
OF	overfrequency	RFI	radio frequency interference	TCP	transmission control protocol
opt.	option, optional	RH	round head	TD	time delay
OS	oversize, overspeed	RHM	round head machine (screw)	TDC	top dead center
OSHA	Occupational Safety and Health Administration	rly.	Relay	TDEC	time delay engine cooldown
OSHPD	Office of Statewide Health Planning and Development (California)	rms	root mean square	TDEN	time delay emergency to normal
OV	overvoltage	rnd.	Round	TDES	time delay engine start
oz.	ounce	RO	read only	TDNE	time delay normal to emergency
p., pp.	page, pages	ROM	read only memory	TDOE	time delay off to emergency
PC	personal computer	rot.	rotate, rotating	TDON	time delay off to normal
PCB	printed circuit board	rpm	revolutions per minute	temp.	temperature
pF	picofarad	RS	right side	term.	Terminal
PF	power factor	RTDs	resistance temperature detectors	THD	total harmonic distortion
ph., ø	phase	RTU	remote terminal unit	TIF	telephone influence factor
PHC	Phillips® head Crimptiter (screw)	RTV	room temperature vulcanization	tol.	Tolerance
PHH	Phillips® hex head (screw)	RW	read/write	turbo.	Turbocharger
PHM	pan head machine (screw)	SAE	Society of Automotive Engineers	typ.	typical (same in multiple locations)
PLC	programmable logic control	scfm	standard cubic feet per minute	UF	underfrequency

UHF	ultrahigh frequency
UIF	user interface
UL	Underwriter's Laboratories, Inc.
UNC	unified coarse thread (was NC)
UNF	unified fine thread (was NF)
univ.	universal
URL	uniform resource locator (web address)
US	undersize, underspeed
UV	ultraviolet, undervoltage
V	volt
VAC	volts alternating current
VAR	voltampere reactive
VDC	volts direct current
VFD	vacuum fluorescent display
VGA	video graphics adapter
VHF	very high frequency
W	watt
WCR	withstand and closing rating
w/	with
WO	write only
w/o	without
wt.	weight
xfmr	transformer

Appendix B. Common Hardware Application Guidelines

Use the information below and on the following pages to identify proper fastening techniques when no specific reference for reassembly is made.

Bolt/Screw Length: When bolt/screw length is not given, use Figure 227 as a guide. As a general rule, a minimum length of one thread beyond the nut and a maximum length of 1/2 the bolt/screw diameter beyond the nut is the preferred method.

Washers and Nuts: Use split lock washers as a bolt locking device where specified. Use SAE flat washers with whiz nuts, spirallock nuts, or standard nuts and preloading (torque) of the bolt in all other applications.

See the Torque Specifications in the appendix and other torque specifications in the service literature.

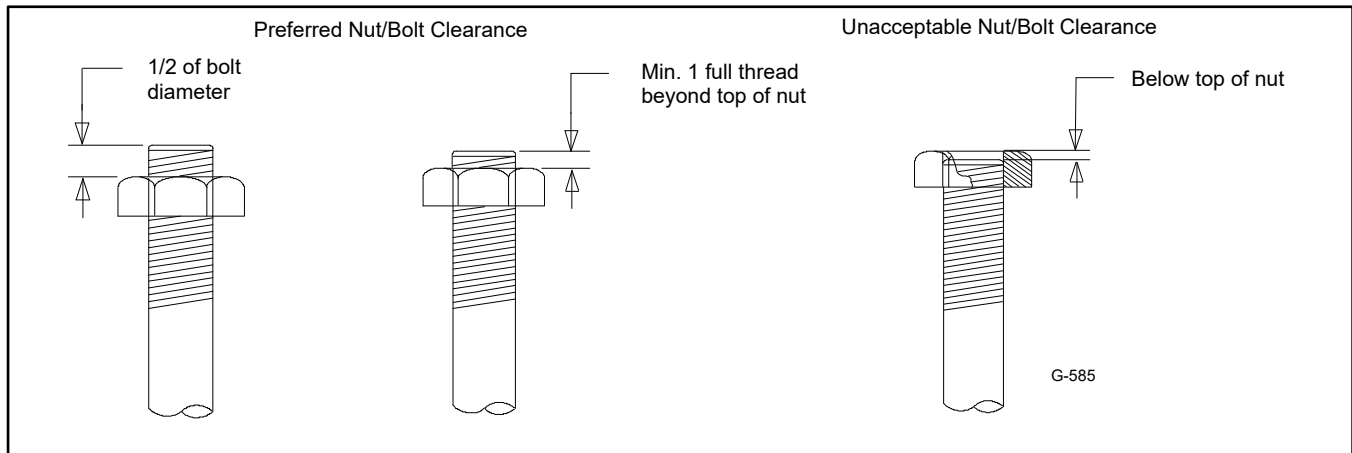

Figure 227 Acceptable Bolt Lengths

Steps for common hardware application:

1. Determine entry hole type: round or slotted.
2. Determine exit hole type: fixed female thread (weld nut), round, or slotted.
3. For round and slotted exit holes, determine if hardware is greater than 1/2 inch in diameter, or 1/2 inch in diameter or less. Hardware that is greater than 1/2 inch in diameter takes a standard nut and SAE washer. Hardware 1/2 inch or less in diameter can take a properly torqued whiz nut or spirallock nut. See Figure 228.
4. Follow these SAE washer rules after determining exit hole type:
 - a. Always use a washer between hardware and a slot.
 - b. Always use a washer under a nut (see step 2 above for exception).
 - c. Use a washer under a bolt when the female thread is fixed (weld nut).
5. Refer to Figure 228, which depicts the preceding hardware configuration possibilities.

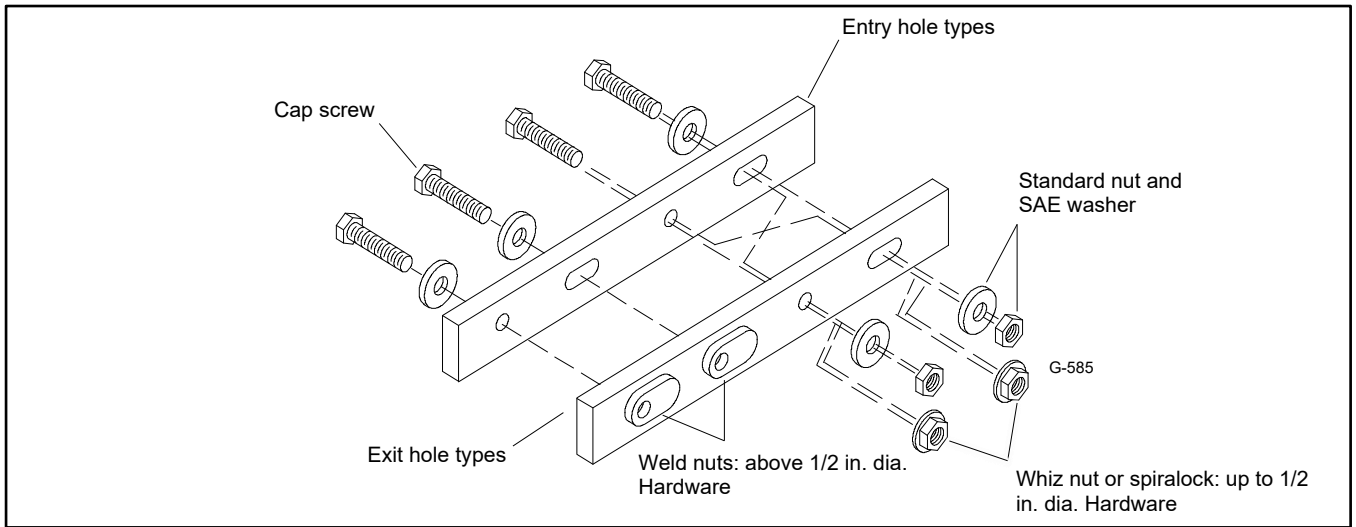

Figure 228 Acceptable Hardware Combinations

Appendix C. Torque Specifications

American Standard Fasteners Torque Specifications										
Size	Assembled into Cast Iron or Steel									Assembled into Aluminum
	Grade 2			Grade 5			Grade 8			
8-32	2.0	Nm	(18 in. lb.)	3.1	Nm	(27 in. lb.)	-			
10-24	3.2	Nm	(28 in. lb.)	4.9	Nm	(43 in. lb.)	-			
10-32	3.6	Nm	(32 in. lb.)	5.5	Nm	(49 in. lb.)	-			
12-24	5.0	Nm	(44 in. lb.)	7.7	Nm	(68 in. lb.)	-			
1/4-20	7.6	Nm	(67 in. lb.)	11.6	Nm	(103 in. lb.)	16.5	Nm	(146 in. lb.)	
1/4-28	8.6	Nm	(76 in. lb.)	13.2	Nm	(117 in. lb.)	18.8	Nm	(166 in. lb.)	
5/16-18	15.5	Nm	(137 in. lb.)	24.0	Nm	(212 in. lb.)	33.9	Nm	(300 in. lb.)	
5/16-24	17.1	Nm	(151 in. lb.)	26.4	Nm	(234 in. lb.)	40	Nm	(28 ft. lb.)	
3/8-16	27	Nm	(243 in. lb.)	42	Nm	(31 ft. lb.)	60	Nm	(44 ft. lb.)	
3/8-24	31	Nm	(274 in. lb.)	47	Nm	(35 ft. lb.)	68	Nm	(50 ft. lb.)	
7/16-14	43	Nm	(32 ft. lb.)	68	Nm	(50 ft. lb.)	96	Nm	(71 ft. lb.)	
7/16-20	49	Nm	(36 ft. lb.)	76	Nm	(56 ft. lb.)	107	Nm	(79 ft. lb.)	
1/2-13	66	Nm	(49 ft. lb.)	103	Nm	(76 ft. lb.)	146	Nm	(108 ft. lb.)	
1/2-20	75	Nm	(55 ft. lb.)	117	Nm	(86 ft. lb.)	164	Nm	(121 ft. lb.)	
9/16-12	96	Nm	(71 ft. lb.)	149	Nm	(110 ft. lb.)	210	Nm	(155 ft. lb.)	
9/16-18	107	Nm	(79 ft. lb.)	165	Nm	(122 ft. lb.)	235	Nm	(173 ft. lb.)	
5/8-11	133	Nm	(98 ft. lb.)	206	Nm	(152 ft. lb.)	290	Nm	(214 ft. lb.)	
5/8-18	150	Nm	(111 ft. lb.)	232	Nm	(171 ft. lb.)	328	Nm	(242 ft. lb.)	
3/4-10	-	-	-	365	Nm	(269 ft. lb.)	515	Nm	(380 ft. lb.)	
3/4-16	-	-	-	405	Nm	(299 ft. lb.)	572	Nm	(422 ft. lb.)	
1-8	-	-	-	881	Nm	(650 ft. lb.)	1245	Nm	(918 ft. lb.)	
1-12	-	-	-	961	Nm	(709 ft. lb.)	1357	Nm	(1001 ft. lb.)	
Metric Fasteners Torque Specifications, Measured in Nm (ft. lb.)										
Size (mm)	Assemblies into Cast Iron or Steel								Assembled into Aluminum	
	Grade 5.8		Grade 8.8		Grade 10.9		Grade 12.9			
Mxxx-04xxx-xx	1.9	(1.4)	2.9	(2.1)	4.3	(3.2)	4.3	(3.2)	See Note 3	
Mxxx-05xxx-xx	3.8	(2.8)	5.8	(4.3)	8.5	(6.3)	8.5	(6.3)		
Mxxx-06xxx-xx	6.5	(4.8)	10.4	(7.7)	14.7	(11)	17.6	(13)		
Mxxx-08xxx-xx	16	(12)	25	(17)	36	(26)	43	(31)		
Mxxx-08xxx-xxF	17	(13)	27	(20)	38	(28)	46	(34)		
Mxxx-10xxx-xx	31	(23)	50	(37)	70	(52)	85	(62)		
Mxxx-10xxx-xxF	33	(24)	53	(39)	74	(55)	89	(66)		
Mxxx-12xxx-xx	55	(40)	87	(64)	123	(91)	147	(109)		
Mxxx-12xxx-xxF	60	(44)	95	(70)	134	(99)	161	(119)		
Mxxx-14xxx-xx	87	(64)	135	(103)	196	(145)	236	(174)		
Mxxx-14xxx-xxF	94	(69)	151	(111)	212	(156)	254	(188)		
Mxxx-16xxx-xx	135	(100)	217	(160)	305	(225)	365	(270)		
Mxxx-16xxx-xxF	145	(107)	231	(171)	325	(240)	390	(288)		
Mxxx-18xxx-xx	187	(138)	299	(221)	421	(310)	505	(373)		
Mxxx-18xxx-xxF	210	(155)	336	(248)	473	(349)	567	(419)		
Mxxx-20xxx-xx	264	(195)	423	(312)	595	(439)	714	(526)		
Mxxx-20xxx-xxF	293	(216)	469	(346)	660	(487)	792	(584)		
Mxxx-22xxx-xx	360	(266)	576	(425)	811	(598)	973	(718)		
Mxxx-22xxx-xxF	396	(292)	633	(467)	890	(657)	1068	(788)		
Mxxx-24xxx-xx	457	(337)	731	(539)	1028	(758)	1233	(910)		
Mxxx-24xxx-xxF	498	(367)	797	(588)	1121	(827)	1345	(992)		
Mxxx-27xxx-xx	-	-	1072	(790)	1507	(1112)	1809	(1334)		
Mxxx-27xxx-xxF	-	-	1156	(853)	1626	(1199)	1952	(1439)		
Mxxx-30xxx-xx	-	-	1453	(1072)	2043	(1507)	2452	(1809)		

Notes:

1. The torque values above are general guidelines. Always use the torque values specified in the service manuals and/or assembly drawings when they differ from the above torque values.
2. The torque values above are based on new plated threads. Increase torque values by 15% if non-plated threads are used.
3. At minimum, hardware threaded into aluminum must have two diameters of thread engagement. Hardware threaded into steel and cast iron must have 1.25 diameters of thread.
4. Torque values are calculated as equivalent stress loading on American hardware with an approximate preload of 75% of proof strength and a friction coefficient of 0.2.

Notes

Appendix D. Fuel Physical Properties

Physical Property @ 15°C (60°F)	Butane	Propane	Natural Gas	Manufactured or Sewage Gas	Gasoline	Diesel Fuel
Normal atmospheric state	Gas	Gas	Gas	Gas	Liquid	Liquid
Boiling point, Initial, °C (°F)	-	-	-	-	36 (97)	177 (350)
End, °C (°F)	0 (32)	42 (-44)	-162 (-259)	-	216 (420)	357 (675)
Heating value, Btu /gal. (net, LHV*)	94670	83340	63310	-	116400	130300
/gal. (gross)	102032	91500	-	-	124600	139000
/ft ³ (gas)	3264	2516	1000	600-700	6390	-
Density, ft ³ of gas/gal.	31.26	36.39	57.75	-	19.5	-
Wt./gal. liquid, lb.	4.81	4.24	2.65	-	6.16	7.08
Octane Number Research	94	110+	110+	-	80-100	-
Motor	90	97	-	-	75-90	-

* Lower Heating Value

Figure 229 Engine Fuels, Physical Properties

Characteristic, LP Gas*	Butane	Propane
Formula	C ₄ H ₁₀	C ₃ H ₈
Boiling point, °C (°F)	0 (32)	-42 (-44)
Specific gravity of gas (air = 1.00)	2.00	1.53
Specific gravity of liquid (water = 1.00)	0.58	0.51
Btu/lb. of gas	21221	21591
Ft ³ . of vapor at 16°C (60°F)/lb. of liquid at 16°C (60°F)	6.506	8.547
Latent heat of vaporization at boiling point, Btu/gal.	808.0	785.0
Combustion Data:	31.02	23.86
Ft ³ air required to burn 1 ft.3 of gas	N/A	-104 (-156)
Flash point, °C (°F)	482-538	493-549
Ignition temperature in air, °C (°F)	(9900-1000)	(920-1020)
Max. flame temperature in air, °C (°F)	1991 (3615)	1979 (3595)
Limits of inflammability, percentage of gas in air mixture:		
At lower limit, %	1.9	2.4
At upper limit, %	8.6	9.6
Octane Number (ISO-Octane = 100)	92	Over 100

* Commercial quality. Figures shown in this chart represent average values.

Figure 230 Additional LP Gas Characteristics

Notes

Appendix E. Gas Fuel Vapor Pressures

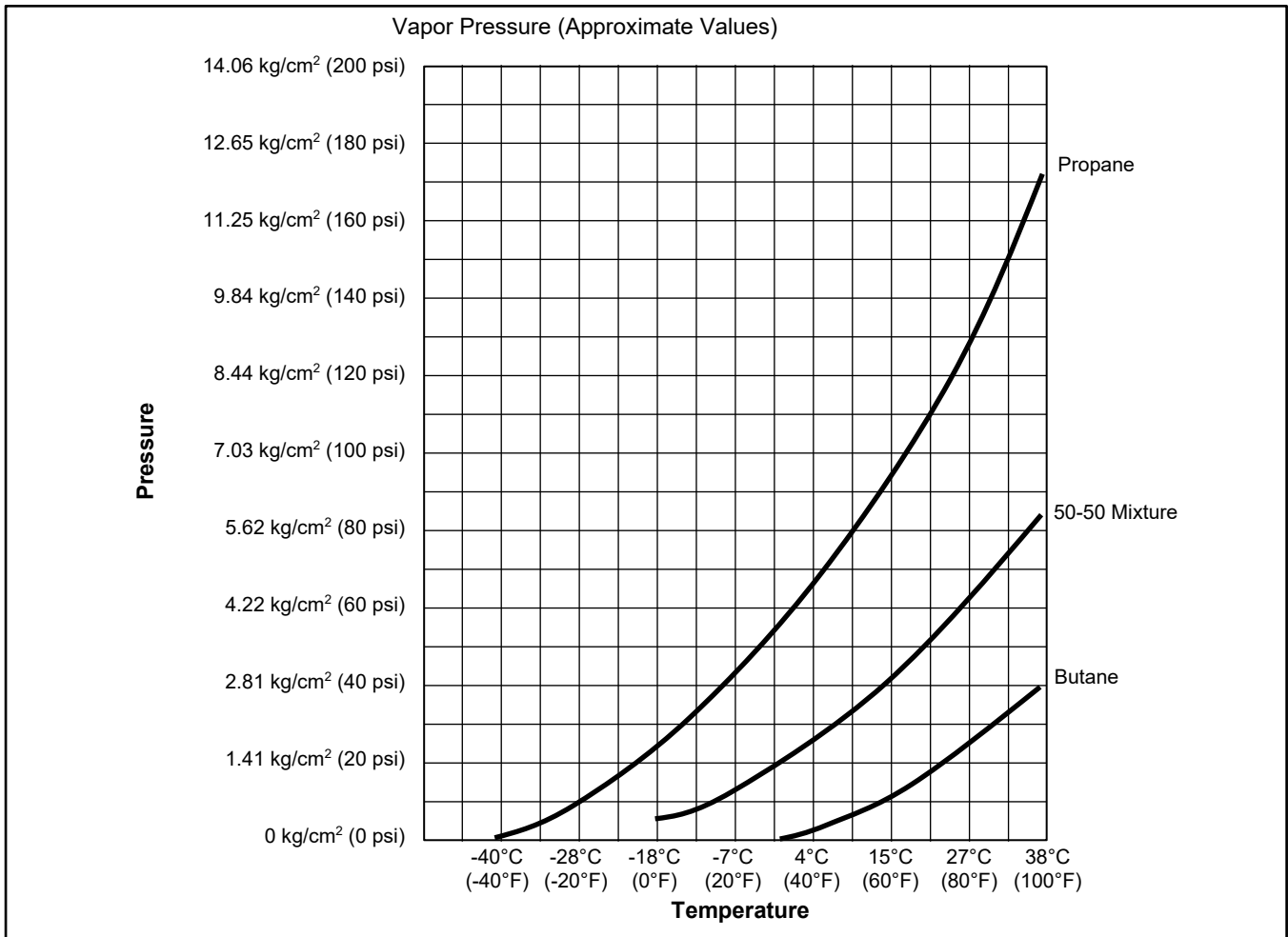

Figure 231 Vapor Pressures of LP Gases Graph

Temperature, °C (°F)	Approximate Pressure, kg/m ² (PSIG)		
	Propane	50/50 Mixture	Butane
-40 (-40)	0.1 (1)	-	
-36 (-33)	0.4 (5)	-	
-28 (-20)	0.7 (10)	-	
-23 (-10)	1.2 (17)	0.2 (3)	
-18 (0)	1.7 (24)	0.4 (5)	
-12 (10)	2.2 (32)	0.6 (8)	
-7 (20)	3.0 (42)	0.9 (13)	
-1 (30)	3.7 (52)	1.3 (19)	
4 (40)	4.6 (65)	1.8 (26)	0.1 (2)
10 (50)	5.5 (78)	2.4 (34)	0.5 (7)
15 (60)	6.5 (93)	3.0 (42)	0.8 (12)
21 (70)	7.7 (109)	3.5 (50)	1.2 (17)
27 (80)	9.6 (136)	4.2 (60)	1.7 (24)
32 (90)	10.3 (147)	5.1 (72)	2.2 (32)
38 (100)	11.9 (169)	6.0 (85)	2.8 (40)
43 (110)	14.1 (200)	7.0 (100)	3.5 (50)

Figure 232 Vapor Pressures of LP Gases Table

Notes

Appendix F. Gas Fuel System Installation Planning

Determining Propane Cylinder Quantity

Guide for Installing 100 lb. Cylinders

For continuous draws where temperatures may reach -18°C (0°F). Assume the vaporization rate of 100 lb. cylinder as approximately 50000 Btu/hr.

$$\text{Number of cylinders/side} = \frac{\text{Total load in Btu}}{50000}$$

Example:

Assume total load = 20000 Btu/hour.

$$\text{Cylinders/side} = \frac{20000}{50000} = 4 \text{ cylinders/side}$$

The chart in Figure 233 shows the vaporization rate of containers in terms of the temperature of the liquid and the wet surface area of the container. When the temperature is lower or if the container contains less liquid, the vaporization rate of the container is a lower value.

Lb. of Propane in Cyl.	Maximum Continuous Draw In Btu/Hour At Various Temperatures in $^{\circ}\text{C}$ ($^{\circ}\text{F}$)				
	-18°C (0°F)	-7°C (20°F)	4°C (40°F)	16°C (60°F)	21°C (70°F)
100	113000	167000	214000	277000	300000
90	104000	152000	200000	247000	277000
80	94000	137000	180000	214000	236000
70	83000	122000	160000	199000	214000
60	75000	109000	140000	176000	192000
50	64000	94000	125000	154000	167000
40	55000	79000	105000	131000	141000
30	45000	66000	85000	107000	118000
20	36000	51000	68000	83000	92000
10	28000	38000	49000	60000	66000

Figure 233 Vaporization Rate, 100 lb. Propane Cylinders, Approximate

Determining Propane Vaporization Capacity

Guide for ASME LP Gas Storage Containers

% of Container Filled	K Equals	Propane* Vaporization Capacity at -18°C (0°F) in Btu/Hr.**
60	100	$D \times L \times 100$
50	90	$D \times L \times 90$
40	80	$D \times L \times 80$
30	70	$D \times L \times 70$
20	60	$D \times L \times 60$
10	45	$D \times L \times 45$

* These formulae allow for the temperature of the liquid to refrigerate to -29°C (-20°F), producing a temperature differential of -7°C (20°F) for the transfer of heat from the air to the container's wetted surface and then into the liquid. The vapor space area of the vessel is not considered since its effect is negligible.
 ** D=Outside diameter in inches
 L=Overall length in inches
 K=Constant for percent volume of liquid in container.

Figure 234 Propane Vaporization Capacity

Vaporizing Capacities for Other Air Temperatures

Multiply the results obtained with the formulae in Figure 234 by one of the factors in the following table for the prevailing air temperature.

Prevailing Air Temperature		Multiplier
-26°C	(-15°F)	0.25
-23°C	(-10°F)	0.50
-21°C	(-5°F)	0.75
-18°C	(0°F)	1.00
-15°C	(5°F)	1.25
-12°C	(10°F)	1.50
-9°C	(15°F)	1.75
-7°C	(20°F)	2.00

Figure 235 Propane Vaporization Capacity

Notes

TP-5700 4/26ae

© 2026 - Discovery Energy, LLC - All rights reserved.



For the nearest sales and service,
go to powersystems.rehko.com