

**Tier 3 EPA-Certified for Stationary
 Emergency Applications**

Ratings Range

Standby:	kW	60 Hz
	kVA	
		300
		375

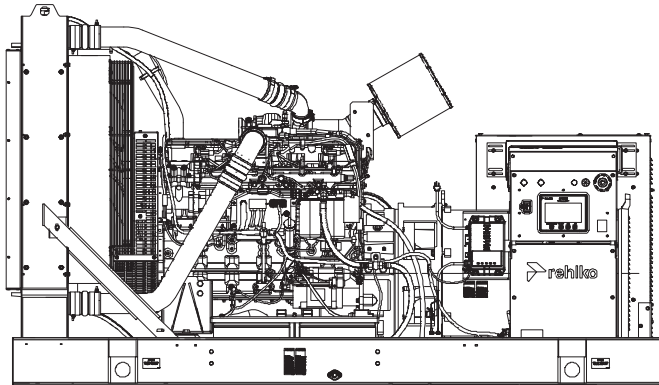

Standard Features

- One-source responsibility for the generating system and accessories.
- Approved for use with certified renewable Hydrotreated Vegetable Oil (HVO)/Renewable Diesel (RD) fuels compliant with EN15940/ASTM D975.
- The generator set and its components are prototype-tested, factory-built, and production-tested.
- The generator set offers a cULus listing (UL 2200 and CSA C22.2 No. 100).
- The generator set accepts rated load in one step.
- The generator set meets NFPA 110, Level 1, when equipped with the necessary accessories and installed per NFPA standards.
- A 2-year, 1000-hour limited warranty covers all generator set systems and components.
 - Extendable to a five-year, 2500-hour comprehensive warranty with a registered service contract through a distributor, dealer, or authorized service representative.
- Five-year basic, five-year comprehensive, and 10-year major components limited warranties are also available for purchase in some jurisdictions.
- Other features:
 - Rehlko designed controllers for one-source system integration and remote communication. See Controllers on page 3.
 - The low coolant level and high coolant temperature sensors protect the generator set from overheating.
 - Integral vibration isolation eliminates the need for under-unit vibration spring isolators.
- Mount up to two circuit breakers to allow circuit protection of selected priority loads.

Generator Set Ratings

Alternator	Voltage	Ph	Hz	130°C Rise Standby Rating	
				kW/kVA	Amps
KH02216TO4D	120/208	3	60	300/375	1041
	277/480	3	60	300/375	452
	347/600	3	60	300/375	361

RATINGS: All three-phase units are rated at 0.8 power factor. All single-phase units are rated at 1.0 power factor. Standby Ratings: The standby rating is applicable to varying loads for the duration of a power outage. There is no overload capability for this rating. Ratings are in accordance with ISO-8528-1 and ISO-3046-1. For limited running time, consult the factory. Obtain technical information bulletin (TIB-101) for ratings guidelines, complete ratings definitions, and site condition derates. The generator set manufacturer reserves the right to change the design or specifications without notice and without any obligation or liability whatsoever.

Application Data

Engine

Engine Specifications

Engine model	KD09L06T-6DDS
Engine type	4- Cycle, Turbocharged, Charge Air Cooled
Cylinder arrangement	6 Inline
Displacement, L (cu. in.)	8.9 (543)
Bore and stroke, mm (in.)	114 x 145 (4.48 x 5.7)
Compression ratio	16.1:1
Piston speed, m/min. (ft./min.)	522 (1712)
Main bearings: quantity, type	7, Replaceable Insert
Rated rpm	1800
Max. power at rated rpm, kWm (BHP)	346 (464)
Governor: type, make/model	Electronic
Frequency regulation, no-load to full-load	Isochronous
Frequency regulation, steady state	±0.25%
Frequency	Fixed
Air cleaner type, all models	Dry

Lubrication

Lubricating System

Type	Full Pressure
Oil pan capacity, L (qt.) §	23.8 (25.1)
Oil pan capacity with filter, L (qt.) §	26.5 (28)
Oil filter: quantity, type §	1, Spin-on
§ Rehiko recommends the use of Rehiko Genuine oil and filters.	

Fuel

Fuel System

Recommended fuel	#2 Ultra Low Sulfur Diesel/HVO/RD
Max. fuel flow, Lph (gph)	159.0 (42.1)
Fuel supply line, min. ID, mm (in.)	15.9 (0.62)
Fuel return line, min. ID, mm (in.)	12.7 (0.5)
Min Fuel supply Pressure, kPa (in. Hg)	-20 (-5.9)
Max Fuel supply Pressure, kPa (in. Hg)	69 (20.3)
Max. return line restriction, kPa (in. Hg)	34 (10)
Fuel filter	
Quantity, Primary	One
Quantity, Water Separator	One

Fuel Consumption**

Diesel, Lph (gph) at % load	Standby Rating	
100%	83.7	(22.2)
75%	67.6	(17.9)
50%	50.7	(13.4)
25%	27.3	(7.3)

** Volumetric Fuel consumption is up to 4% higher when using HVO/RD than #2 ULSD.

Cooling

Radiator System

Ambient temperature, °C (°F)*	50 (122)
Radiator system capacity, including engine, L (gal.)	37.0 (9.8)
Engine jacket water capacity, L (gal.)	11 (3)
Engine jacket water flow, Lpm (gpm)	273 (72)
Charge air cooler inlet temperature at 25°C (77°F) ambient	228 (442)
Heat rejected to cooling water at rated kW, dry exhaust, kW (Btu/min.)	110.4 (6279)
Heat rejected to air charge cooler at rated kW, dry exhaust, kW (Btu/min.)	89 (5062)
Turbocharger boost (abs) kPa (psi)	383 (56)
Water pump type	Vane
Fan diameter, including blades, mm (in.)	765 (30.2)
Fan, kWm (HP)	6.5 (9)
Max. restriction of cooling air, intake and discharge side of radiator, kPa (in. H ₂ O)	See TIB-118
* Enclosure with enclosed silencer reduces ambient temperature capability by 5°C (9°F).	

Exhaust

Exhaust System

Exhaust manifold type	Dry
Exhaust flow at rated kW, m ³ /min. (cfm)	66 (2341)
Exhaust temperature at rated kW, dry exhaust, °C (°F)	525 (977)
Maximum allowable back pressure, kPa (in. Hg)	10.2 (3)
Exhaust outlet size at engine hookup, mm (in.)	See ADV drawing

Engine Electrical

Engine Electrical System

Ignition System	Compression Ignition
Battery charging alternator:	24 Volt
Ground (negative/positive)	Negative
Volts (DC)	24
Ampere rating	70
Starter motor rated voltage (DC)	1 @ 8 kW
Battery, recommended cold cranking amps (CCA):	
Battery voltage (DC)	12
Quantity, CCA rating each	Two, 750

Operation Requirements

Air Requirements

Radiator-cooled cooling air, m ³ /min. (scfm)‡	345 (12200)
Combustion air, m ³ /min. (cfm)	25.4 (899)
Heat rejected to ambient air:	
Engine, kW (Btu/min.)	35.7 (2033)
Alternator, kW (Btu/min.)	20.3 (1155)
Max. combustion air restriction, kPa (in. H ₂ O)	6.2 (25.0)
‡ Air density = 1.20 kg/m ³ (0.075 lbm/ft ³)	

Alternator Specifications

Specifications	Alternator
Type	4-Pole, Rotating-Field
Exciter type	Brushless, Auxiliary Winding, Brushless, Permanent-Magnet (optional)
Voltage regulator	Solid State, Volts/Hz
Bearing: quantity, type	1, Sealed
Coupling	Flexible Disc
Unbalanced load capability	See alternator datasheet, TIB-102

Note: For additional alternator information, refer to TIB-102.

- The pilot-excited, permanent magnet (PM) alternator provides superior short-circuit capability.
- NEMA MG1, IEEE, and ANSI standards compliance for temperature rise and motor starting.
- Sustained short-circuit current enabling downstream circuit breakers to trip without collapsing the alternator field.
- Self-ventilated and dripproof construction.
- Windings are vacuum-impregnated with polyester resin for dependability and long life.
- Superior voltage waveform from a two-thirds pitch stator and skewed rotor.

NOTE: See TIB-102 Alternator Data Sheets for alternator application data and ratings, efficiency curves, voltage dip with motor starting curves, and short circuit decrement curves.

Controllers



APM402 Controller

Provides advanced control, system monitoring, and system diagnostics for optimum performance and compatibility.

- Digital display and menu control provide easy local data access
- Measurements are selectable in metric or English units
- Remote communication thru a PC via network or serial configuration
- Controller supports Modbus® protocol
- Integrated hybrid voltage regulator with ±0.5% regulation
- Built-in alternator thermal overload protection
- NFPA 110 Level 1 capability

Refer to G6-161 for additional controller features and accessories.



APM603 Controller

Provides advanced control, system monitoring, and system diagnostics for optimum performance and compatibility.

- 7-inch graphic display with touch screen and menu control provides easy local data access
- Measurements are selectable in metric or English units
- Load management to connect and disconnect loads as required
- Controller supports Modbus® RTU, Modbus® TCP, SNMP and BACnet®
- Integrated voltage regulator with ±0.25% regulation
- Built-in alternator thermal overload protection
- UL-listed overcurrent protective device
- NFPA 110 Level 1 capability

Refer to G6-162 for additional controller features and accessories.

Modbus® is a registered trademark of Schneider Electric.
 BACnet® is a registered trademark of ASHRAE.

Standard Features

- Alternator Protection
- Battery Rack and Cables
- Local Emergency Stop Switch
- Oil Drain Extension
- Operation and Installation Literature
- Common Failure Relay (APM603 controller only)
- Run Relay (APM603 controller only)
- Air Cleaner Restriction Indicator
- Engine Fluids Added

Available Options

Load Connection Option

- Bus Bar
- Generator Mounted Circuit Breaker
 - AIC Rating: 18kAIC @480V, 35kAIC @480V
 - Duty Cycle: 80%, 100%
 - Trip Unit: Thermal Magnetic, Electronic Trip (LSI or LSIG)
- Generator Mounted Paralleling Circuit Breaker (Electrically Operated)
 - AIC Rating: 35kAIC
 - Duty Cycle: 100%
 - Electronic Trip with Ground Fault (LSIG)

Approvals and Listings

- cULus (UL 2200 and CSA)
- California OSHPD Pre- Approval
- Hurricane Rated Enclosure
- IBC Seismic Certification
- Florida Dept. of Environmental Protection (FDEP) Compliance (fuel tanks only)

Enclosed Unit

- Sound Enclosure (with enclosed critical silencer)
- Weather Enclosure (with enclosed critical silencer)

Open Unit

- Exhaust Silencer, Critical (kit: PA-354809)
- Flexible Exhaust Connector

Fuel System

- Flexible Fuel Lines
- Fuel Pressure Gauge
- Subbase Fuel Tanks

Controller

- Common Failure Relay (APM402 controller only)
- Run Relay (APM402 controller only)
- Two Input/Five Output Module (APM402 controller only)
- Four Input/Fifteen Output Module
- Lockable Emergency Stop Switch
- Remote Emergency Stop Switch
- Remote Serial Annunciator Panel
- Manual Key Switch
- Manual Speed Adjust (APM402 controller only)

Starting Aids

- Block Heater, 2500 W, 120 V, 1 Ph
- Block Heater, 2500 W, 208 V, 1 Ph
- Block Heater, 2500 W, 240 V, 1 Ph

Cooling System

- Radiator Duct Flange

Electrical System

- Generator (Alternator Strip) Heater
- Battery
- Battery Charger (6A or 10A)
- Temperature Compensation for 10A Battery Charger
- Battery Heater

Miscellaneous

- Air Cleaner, Heavy Duty
- Certified Test Report
- Rated Power Factor Testing
- Rodent Guards

Literature

- General Maintenance
- NFPA 110
- Overhaul
- Production

Warranty

- 5-Year Basic Limited Warranty
- 5-Year Comprehensive Limited Warranty
- 10-year Major Components Limited Warranty

Dimensions and Weights

Overall Size, L x W x H, mm (in.): 2830 x 1350 x 1633
(111.4 x 53.1 x 64.3)

Weight (radiator model), wet, kg (lb.): 2170 (4785)

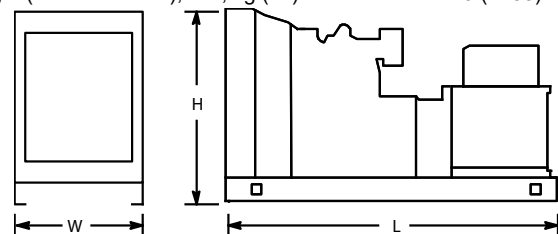

NOTE: This drawing is provided for reference only and should not be used for planning installation. Contact your local distributor for more detailed information.