

**Tier 3 EPA-Certified for Stationary
Emergency Applications**

Ratings Range

		60 Hz
Standby:	kW	44-52
	kVA	44-65
Prime:	kW	40-47
	kVA	40-58

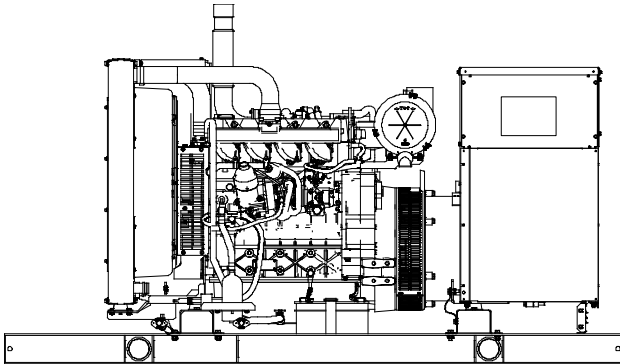

Model with TM Engine Shown

Generator Set Ratings

Alternator	Voltage	Ph	Hz	130°C Rise Standby Rating		105°C Rise Prime Rating	
				kW/kVA	Amps	kW/kVA	Amps
4P7BX	120/208	3	60	51/63	176	46/57	159
	120/240	3	60	49/61	147	44/55	132
	120/240	1	60	44/44	183	40/40	166
	277/480	3	60	51/63	76	46/57	69
	347/600	3	60	51/63	62	46/57	56
4P8X	120/208	3	60	52/65	180	47/58	163
	120/240	3	60	50/62	150	45/56	135
	120/240	1	60	50/50	208	45/45	187
	277/480	3	60	52/65	78	47/58	70
	347/600	3	60	52/65	62	47/58	56
4P10X	120/208	3	60	52/65	180	47/58	163
	120/240	3	60	50/62	150	45/56	135
	120/240	1	60	50/50	208	45/45	187
	277/480	3	60	52/65	78	47/58	70
	347/600	3	60	52/65	62	47/58	56
4Q7BX	120/240	1	60	48/48	200	43/43	179
4Q10X	120/240	1	60	50/50	208	45/45	187

Standard Features

- Rehiko provides one-source responsibility for the generating system and accessories.
- Approved for use with certified renewable Hydrotreated Vegetable Oil (HVO) / Renewable Diesel (RD) fuels compliant with EN15940 / ASTM D975.
- The generator set and its components are prototype-tested, factory-built, and production-tested.
- The 60 Hz generator set offers a UL 2200 listing.
- The generator set accepts rated load in one step.
- The 60 Hz generator set meets NFPA 110, Level 1, when equipped with the necessary accessories and installed per NFPA standards.
- The generator set engine is certified to meet the Environmental Protection Agency (EPA) emergency stationary emissions requirements.
- A one-year limited warranty covers all generator set systems and components. Two- and five-year extended limited warranties are also available for purchase in some jurisdictions.
- Alternator features:
 - The unique Fast-Response® X excitation system delivers excellent voltage response and short-circuit capability using a rare-earth, permanent magnet (PM)-excited alternator.
 - The brushless, rotating-field alternator has broadrange reconnectability.
- Other features:
 - Rehiko designed controllers for one-source system integration and remote communication. See Controllers on page 3.
 - The low coolant level shutdown prevents overheating (standard on radiator models only).
 - Integral vibration isolation eliminates the need for under-unit vibration spring isolators.
 - The generator set for 49-state applications is equipped with the KDI 3404 TM engine. The generator set that is CARB compliant/California South Coast Air Quality Management District (SCAQMD) pre-certified is equipped with the KDI 3404 TCR engine.

RATINGS: All three-phase units are rated at 0.8 power factor. All single-phase units are rated at 1.0 power factor. *Standby Ratings:* Standby rating is applicable to varying loads for the duration of a power outage. There is no overload capability for this rating. *Prime Power Ratings:* At varying load, the number of generator set operating hours is unlimited. A 10% overload capacity is available for one hour in twelve. Ratings are in accordance with ISO-8528-1 and ISO-3046-1. For limited running time and continuous ratings, consult the factory. Obtain the technical information bulletin (TIB-101) for ratings guidelines, complete ratings definitions, and site condition derates. The generator set manufacturer reserves the right to change the design or specifications without notice and without any obligation or liability whatsoever.

Alternator Specifications

Specifications	Alternator
Type	4-Pole, Rotating-Field
Exciter type	Brushless, Rare-Earth Permanent Magnet
Leads: quantity, type	12, Reconnectable 4, 110-120/220-240 V
Voltage regulator	Solid State, Volts/Hz
Insulation:	NEMA MG1
Material	Class H
Temperature rise	130°C, Standby
Bearing: quantity, type	1, Sealed
Coupling	Flexible Disc
Amortisseur windings	Full
Voltage regulation, no-load to full-load	Controller Dependent
One-step load acceptance	100% of Rating
Unbalanced load capability	100% of Rated Standby Current

- NEMA MG1, IEEE, and ANSI standards compliance for temperature rise and motor starting.
- Sustained short-circuit current of up to 300% of the rated current for up to 10 seconds.
- Sustained short-circuit current enabling downstream circuit breakers to trip without collapsing the alternator field.
- Self-ventilated and dripproof construction.
- Windings are vacuum-impregnated with epoxy varnish for dependability and long life.
- Superior voltage waveform from a two-thirds pitch stator and skewed rotor.

Specifications	Alternator
Peak motor starting kVA:	(35% dip for voltages below)
480 V 4P7BX (12 lead)	180
480 V 4P8X (12 lead)	261
480 V 4P10X (12 lead)	275
240 V 4Q7BX (4 lead)	113
240 V 4Q10X (4 lead)	144

Application Data

Engine

Engine Specifications	49-State Engine	California SCAQMD
Engine model	KDI	KDI
Engine type	3404TM	3404TCR
Cylinder arrangement	4-Cycle, Turbocharged	
Displacement, L (cu. in.)	4 Inline	
Bore and stroke, mm (in.)	3.4 (207)	
Compression ratio	96 x 116 (3.28 x 4.57)	
Piston speed, m/min. (ft./min.)	18.5:1	17.0:1
Main bearings: quantity, type	418 (1371)	510 (1673)
Rated rpm	5, Replaceable Insert	
Max. power at rated rpm, kWm (BHP)	1800	
Cylinder head material	64 (86)	70 (94)
Crankshaft material	Cast Iron	
Valve material:	Cast Iron	
Intake	Chromium-Silicon Steel	
Exhaust	Chromium Steel	
Governor: type, make/model	Mech. (or Electronic *)	Electronic
Frequency regulation, no-load to full-load	Droop, 5% (or Isochr. *)	Isochronous
Frequency regulation, steady state	±0.5%	±0.28%
Frequency	Fixed	
Air cleaner type, all models	Dry	
* Requires available electronic governor option		

Exhaust

Exhaust System	49-State Engine	California SCAQMD
Exhaust manifold type	Dry	
Exhaust flow at rated kW, m ³ /min. (cfm)	8.8 (310)	
Exhaust temperature at rated kW, dry exhaust, °C (°F)	490 (914)	471 (880)
Minimum/maximum allowable back pressure, kPa (in. Hg)	6 (1.8)/ 9 (2.7)	8 (2.4)/ 13.5 (4.0)
Exhaust outlet size at engine hookup, mm (in.)	63.5 (2.5)	

Engine Electrical

Engine Electrical System	49-State Engine	California SCAQMD
Battery charging alternator:		
Ground (negative/positive)		Negative
Volts (DC)		12
Ampere rating		90
Starter motor rated voltage (DC)		12
Battery, recommended cold cranking amps (CCA):		
Quantity, CCA rating each		One, 650
Battery voltage (DC)		12

Fuel

Fuel System	49-State Engine	California SCAQMD
Fuel supply line, min. ID, mm (in.)	8.0 (0.31)	
Fuel return line, min. ID, mm (in.)	6.0 (0.25)	
Max. lift, engine-driven fuel pump, m (ft.)	6.0 (20.0)	3.7 (12.1)
Max. fuel flow, Lph (gph)	46 (12.2)	87.4 (23.1)
Max. return line restriction, kPa (in. Hg)	20 (5.9)	17.7 (5.2)
Fuel filter		
Prefilter		74 Microns
Primary/Water Separator	5 Microns @ 98% Efficiency	5 Microns @ 95% Efficiency
Recommended fuel		#2 Ultra Low Sulfur Diesel/HVO/RD

Lubrication

Lubricating System	49-State Engine	California SCAQMD
Type	Full Pressure	
Oil pan capacity, L (qt.) §	15.3 (16.2)	
Oil pan capacity with filter, L (qt.) §	15.6 (16.5)	
Oil filter: quantity, type §	1, Cartridge	
Oil cooler	Water-Cooled	
§ Rehiko recommends the use of Rehiko Genuine oil and filters.		

Application Data

Cooling

Radiator System	49State Engine	California SCAQMD
Ambient temperature, °C (°F)*	50 (122)	
Engine jacket water capacity, L (gal.)	4.5 (1.19)	
Radiator system capacity, including engine, L (gal.)	12.3 (3.2)	
Engine jacket water flow, Lpm (gpm)	125 (33)	120 (32)
Heat rejected to cooling water at rated kW, dry exhaust, kW (Btu/min.)	37.8 (2207)	41.3 (2352)
Heat rejected to air charge cooler at rated kW, dry exhaust, kW (Btu/min.)	12 (682)	8.4 (477)
Water pump type	Centrifugal	
Fan diameter, including blades, mm (in.)	597 (23.5)	
Fan, kWm (HP)	1.8 (2.3)	
Max. restriction of cooling air, intake and discharge side of radiator, kPa (in. H ₂ O)	0.125 (0.5)	

* Enclosure with internal silencer reduces ambient temperature capability by 5°C (9°F).

Operation Requirements

Air Requirements	49-State Engine	California SCAQMD
Radiator-cooled cooling air, m ³ /min. (scfm) †	96.3 (3400)	
Combustion air, m ³ /min. (cfm)	4.8 (170)	4.0 (140)
Heat rejected to ambient air:		
Engine, kW (Btu/min.)	13.2 (750)	
Alternator, kW (Btu/min.)	7.6 (435)	
Max. air intake restriction, kPa (in. Hg)	5.2 (1.54)	4.2 (1.24)

† Air density = 1.20 kg/m³ (0.075 lbm/ft³)

Fuel Consumption**

Diesel, Lph (gph) at % load	49-State Engine	
	Standby Rating	
100%	17.4	(4.6)
75%	13.2	(3.5)
50%	9.1	(2.4)
25%	5.3	(1.4)
Diesel, Lph (gph) at % load	Prime Rating	
100%	16.1	(4.2)
75%	12.1	(3.2)
50%	8.3	(2.2)
25%	4.9	(1.3)
Diesel, Lph (gph) at % load	Calif. SCAQMD Engine	
	Standby Rating	
100%	15.2	(4.0)
75%	11.6	(3.1)
50%	8.0	(2.1)
25%	4.6	(1.2)
Diesel, Lph (gph) at % load	Prime Rating	
100%	12.3	(3.2)
75%	10.6	(2.8)
50%	6.6	(1.7)
25%	4.1	(1.1)

** Volumetric Fuel consumption is up to 4% higher when using HVO/RD than #2 ULSD.

Controllers



APM402 Controller

Provides advanced control, system monitoring, and system diagnostics for optimum performance and compatibility.

- Digital display and menu control provide easy local data access
 - Measurements are selectable in metric or English units
 - Remote communication thru a PC via network or serial configuration
 - Controller supports Modbus® protocol
 - Integrated hybrid voltage regulator with ±0.5% regulation
 - Built-in alternator thermal overload protection
 - NFPA 110 Level 1 capability
- Refer to G6-161 for additional controller features and accessories.

Additional Standard Features

- Air Cleaner, Heavy Duty
- Alternator Protection
- Battery Rack and Cables
- Open Crankcase Ventilation
- Oil Drain and Coolant Drain with Hose Barb
- Oil Drain Extension (with narrow skid and enclosure models only)
- Operation and Installation Literature
- Radiator Drain Extension (with enclosure models only)
- Stainless Steel Fasteners on Enclosure (with enclosure models only)

Available Options

Approvals and Listings

- California OSHPD Pre- Approval
- CSA Certified
- IBC Seismic Certification
- UL 2200 Listing

Enclosed Unit

- Sound Enclosure (with enclosed critical silencer)
- Stainless Steel Latches and Hinges
- Weather Enclosure (with enclosed critical silencer)

Open Unit

- Exhaust Silencer, Critical (kit: PA-324470)
- Flexible Exhaust Connector, Stainless Steel

Fuel System

- Flexible Fuel Lines
- Fuel Pressure Gauge (Available with 49-state engine only)
- Subbase Fuel Tanks

Controller

- 15-Relay Dry Contact (SCAQMD engine with APM402 controller only)
- Two Input/Five Output Module (49-state engine with APM402 controller only)
- Key Switch (SCAQMD engine with APM402 controller only)
- Manual Speed Adjust (requires Electronic Governor or SCAQMD engine)
- Remote Annunciator Panel
- Remote Emergency Stop
- Run Relay

Cooling System

- Block Heater (1000 W, 110-120 V)
Recommended for ambient temperatures below 20°C (68°F).
- Block Heater (1400 W, 110-120 V)
Recommended for ambient temperatures below 0°C (32°F).
- Radiator Duct Flange

Electrical System

- Alternator Strip Heater
- Battery
- Battery Charger, Equalize/Float Type
- Battery Heater
- Electronic Governor
- Line Circuit Breaker (NEMA type 1 enclosure)
- Line Circuit Breaker with Shunt Trip (NEMA type 1 enclosure)

Miscellaneous

- Air Cleaner Restriction Indicator
- Engine Fluids Added
- Rated Power Factor Testing
- Rodent Guards

Literature

- General Maintenance
- NFPA 110
- Overhaul
- Production

Warranty

- 2-Year Basic Limited Warranty
- 5-Year Basic Limited Warranty
- 5-Year Comprehensive Limited Warranty

Other Options

- _____
- _____
- _____
- _____
- _____

Dimensions and Weights

Overall Size, L x W x H, mm (in.):

Wide Skid: 2300 x 1040 x 1131

(90.6 x 41.0 x 44.5)

Narrow Skid:

1871 x 780 x 1055

(73.6 x 30.7 x 41.5)

Weight (radiator model), wet, kg (lb.):

841 (1855)

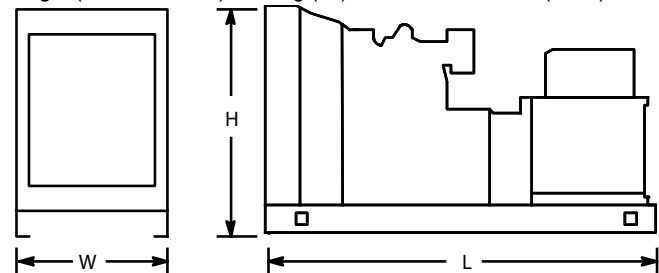

NOTE: This drawing is provided for reference only and should not be used for planning installation. Contact your local distributor for more detailed information.