

Command PRO EFI

ECH940 & ECH980

Service Manual

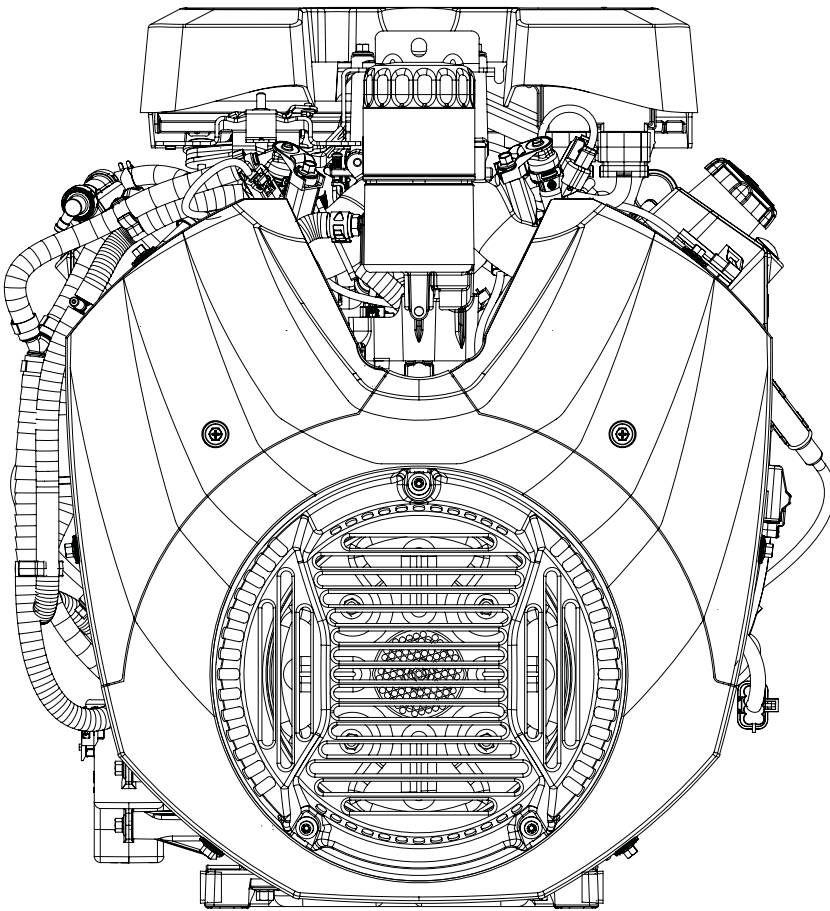

Rehiko Engines
is now Rehiko.

2	Safety
3	Maintenance
5	Specifications
21	Tools and Aids
24	Troubleshooting
29	Air Cleaner/Intake
30	Electronic Fuel Inject (EFI) System
54	Governor System
56	Lubrication System
58	Electrical System
64	Starter System
66	Disassembly/Inspection and Service
83	Reassembly

IMPORTANT: Read all safety precautions and instructions carefully before operating equipment. Refer to operating instruction of equipment that this engine powers.

Ensure engine is stopped and level before performing any maintenance or service.

Safety

SAFETY PRECAUTIONS

WARNING: A hazard that could result in death, serious injury, or substantial property damage.

CAUTION: A hazard that could result in minor personal injury or property damage.

NOTE: is used to notify people of important installation, operation, or maintenance information.

	⚠ WARNING Explosive Fuel can cause fires and severe burns. Do not fill fuel tank while engine is hot or running.
Gasoline is extremely flammable and its vapors can explode if ignited. Store gasoline only in approved containers, in well ventilated, unoccupied buildings, away from sparks or flames. Spilled fuel could ignite if it comes in contact with hot parts or sparks from ignition. Never use gasoline as a cleaning agent.	

	⚠ WARNING Rotating Parts can cause severe injury. Stay away while engine is in operation.
Keep hands, feet, hair, and clothing away from all moving parts to prevent injury. Never operate engine with covers, shrouds, or guards removed.	

	⚠ WARNING Carbon Monoxide can cause severe nausea, fainting or death. Avoid inhaling exhaust fumes. Never run engine indoors or in enclosed spaces.
Engine exhaust gases contain poisonous carbon monoxide. Carbon monoxide is odorless, colorless, and can cause death if inhaled.	

	⚠ WARNING Accidental Starts can cause severe injury or death. Disconnect and ground spark plug lead(s) before servicing.
Before working on engine or equipment, disable engine as follows: 1) Disconnect spark plug lead(s). 2) Disconnect negative (-) battery cable from battery.	

	⚠ WARNING Hot Parts can cause severe burns. Do not touch engine while operating or just after stopping.
Never operate engine with heat shields or guards removed.	

	⚠ WARNING Cleaning Solvents can cause severe injury or death. Use only in well ventilated areas away from ignition sources.
Carburetor cleaners and solvents are extremely flammable. Follow cleaner manufacturer's warnings and instructions on its proper and safe use. Never use gasoline as a cleaning agent.	

	⚠ CAUTION Electrical Shock can cause injury. Do not touch wires while engine is running.
---	--



	⚠ CAUTION Damaging Crankshaft and Flywheel can cause personal injury.
Using improper procedures can lead to broken fragments. Broken fragments could be thrown from engine. Always observe and use precautions and procedures when installing flywheel.	

	⚠ CAUTION Failure to utilize or reassemble debris screen as designed could result in debris screen failure and serious personal injury.
---	---

	⚠ WARNING High Pressure Fluids can puncture skin and cause severe injury or death. Do not work on fuel system without proper training or safety equipment.
Fluid puncture injuries are highly toxic and hazardous. If an injury occurs, seek immediate medical attention.	

	⚠ WARNING Explosive Fuel can cause fires and severe burns. Fuel system ALWAYS remains under HIGH PRESSURE.
Wrap a shop towel completely around fuel pump module connector. Press release button(s) and slowly pull connector away from fuel pump module allowing shop towel to absorb any residual fuel in high pressure fuel line. Any spilled fuel must be completely wiped up immediately.	

MAINTENANCE INSTRUCTIONS

	 WARNING	Before working on engine or equipment, disable engine as follows: 1) Disconnect spark plug lead(s). 2) Disconnect negative (-) battery cable from battery.
	Accidental Starts can cause severe injury or death. Disconnect and ground spark plug lead(s) before servicing.	

Normal maintenance, replacement or repair of emission control devices and systems may be performed by any repair establishment or individual; however, warranty repairs must be performed by a Rehlko authorized dealer.

MAINTENANCE SCHEDULE

Weekly

<ul style="list-style-type: none"> • Check filter minder. 	Air Cleaner/Intake
--	--------------------

Every 25 Hours or Annually¹

<ul style="list-style-type: none"> • Service/replace low-profile precleaner. 	Air Cleaner/Intake
---	--------------------

Every 100 Hours or Annually¹

<ul style="list-style-type: none"> • Change oil. Oil filter is recommended. 	Lubrication System
<ul style="list-style-type: none"> • Remove cooling shrouds and clean cooling areas. 	Air Cleaner/Intake

Every 150 Hours¹

<ul style="list-style-type: none"> • Check heavy-duty air cleaner element. 	Air Cleaner/Intake
<ul style="list-style-type: none"> • Replace low-profile air cleaner element. 	Air Cleaner/Intake
<ul style="list-style-type: none"> • Replace unique Electronic Fuel Injection (EFI) fuel filter. 	
<ul style="list-style-type: none"> • Check oil cooler fins, clean as necessary. 	Lubrication System

Every 200 Hours

<ul style="list-style-type: none"> • Change oil filter. 	Lubrication System
--	--------------------

Every 300 Hours

<ul style="list-style-type: none"> • Replace heavy-duty air cleaner element and check inner element. 	Air Cleaner/Intake
---	--------------------

Every 300 Hours²

<ul style="list-style-type: none"> • Change oil and filter (Xtended Life PRO 10W-50 oil and Xtended Life PRO filter only). 	Lubrication System
---	--------------------

Every 500 Hours or Annually¹

<ul style="list-style-type: none"> • Replace spark plugs and set gap. 	Electrical System
--	-------------------

Every 600 Hours

<ul style="list-style-type: none"> • Replace heavy-duty inner air cleaner element. 	Air Cleaner/Intake
---	--------------------

¹ Perform these procedures more frequently under severe, dusty, dirty conditions.

² Option only if using Xtended Life PRO oil and Xtended Life PRO filter.

REPAIRS/SERVICE PARTS

Rehlko genuine service parts can be purchased from Rehlko authorized dealers. To find a local Rehlko authorized dealer visit Engines.rehlko.com or call 1-800-544-2444 (U.S. and Canada).

Maintenance

OIL RECOMMENDATIONS

Xtended Life PRO 10W-50 Synthetic Oil is the ideal oil for Rehlko engines. It is specifically formulated to extend the oil and oil filter change interval to 300 Hours when paired with a Xtended Life PRO Extended Life Oil Filter.

300-Hour oil and oil filter change intervals are exclusive to and only authorized on Rehlko engines that utilize both the Xtended Life PRO 10W-50 Synthetic Oil and Xtended Life PRO Extended Life Oil Filter. Alternative engine oils and oil filters may be used with Rehlko engines but require 100-Hour oil and 200-Hour oil filter change intervals for proper maintenance. Oil must be API (American Petroleum Institute) service class SJ or higher. Select viscosity based on air temperature at time of operation as shown below.

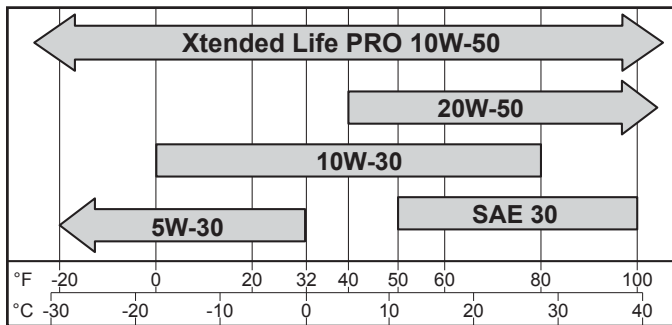

STORAGE

If engine will be out of service for 2 months or more follow procedure below.

1. Add PRO Series fuel treatment or equivalent to fuel tank. Run engine 2-3 minutes to get stabilized fuel into fuel system (failures due to untreated fuel are not warrantable).
2. Change oil while engine is still warm from operation (NOT required if using Xtended Life PRO 10W-50 full-synthetic oil). Remove spark plug(s) and pour about 1 oz. of engine oil into cylinder(s). Replace spark plug(s) and crank engine slowly to distribute oil.
3. Disconnect negative (-) battery cable.
4. Store engine in a clean, dry place.

FUEL RECOMMENDATIONS

	WARNING
	Explosive Fuel can cause fires and severe burns.
	Do not fill fuel tank while engine is hot or running.
Gasoline is extremely flammable and its vapors can explode if ignited. Store gasoline only in approved containers, in well ventilated, unoccupied buildings, away from sparks or flames. Spilled fuel could ignite if it comes in contact with hot parts or sparks from ignition. Never use gasoline as a cleaning agent.	

NOTE: E15, E20 and E85 are NOT approved and should NOT be used; effects of old, stale or contaminated fuel are not warrantable.

Fuel must meet these requirements:

- Clean, fresh, unleaded gasoline.
- Octane rating of 87 (R+M)/2 or higher.
- Research Octane Number (RON) 90 octane minimum.
- Gasoline up to 10% ethyl alcohol, 90% unleaded is acceptable.
- Methyl Tertiary Butyl Ether (MTBE) and unleaded gasoline blend (max 15% MTBE by volume) are approved.
- Do not add oil to gasoline.
- Do not overfill fuel tank.
- Do not use gasoline older than 30 days.

Engine Dimensions with Heavy-Duty Air Cleaner - Flywheel Side

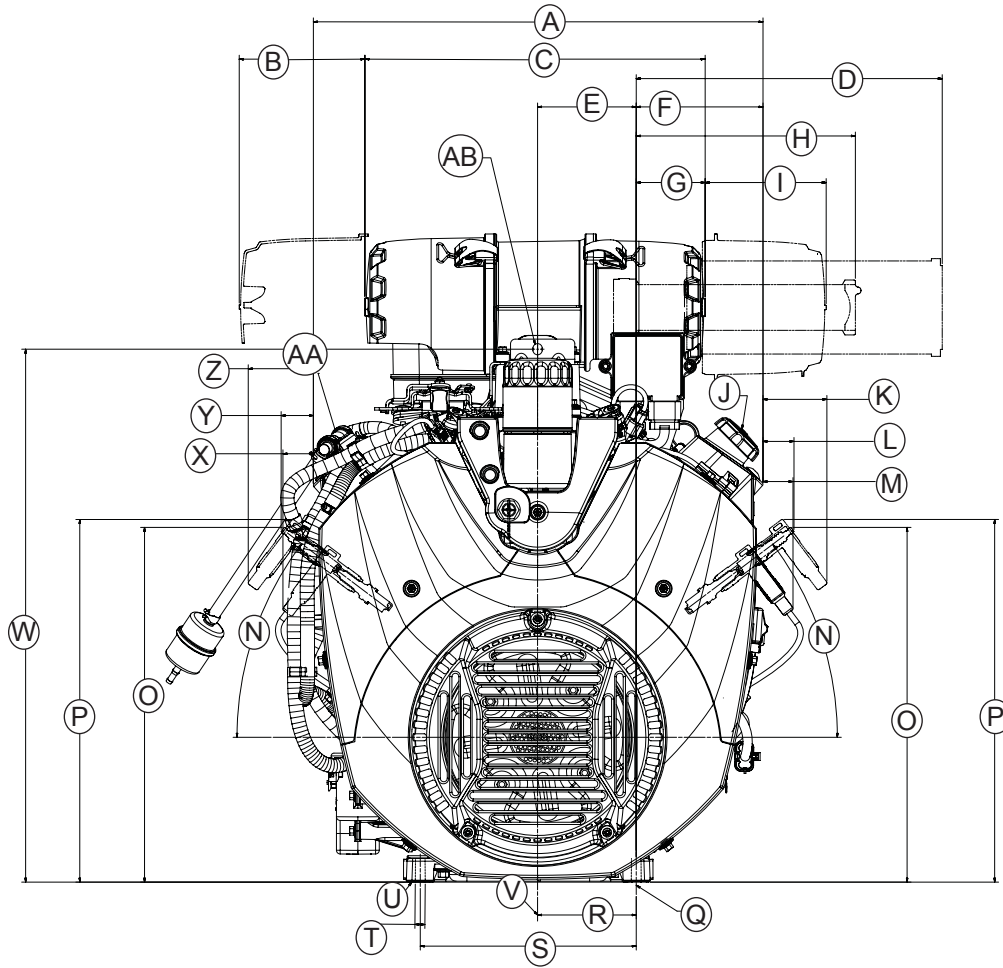

A	483.0 mm (19.02 in.)	B	135.0 mm (5.32 in.) Rain Cap Cover Removal	C	365.5 mm (14.39 in.)	D	328.69 mm (12.94 in.) Primary Air Filter Element Removal
E	105.99 mm (4.17 in.) Lifting Point	F	136.17 mm (5.36 in.)	G	74.03 mm (2.92 in.)	H	235.39 mm (9.27 in.) Safety Air Filter Element Removal
I	130.0 mm (5.12 in.) Air Filter Cover Removal	J	Oil Fill	K	68.62 mm (2.70 in.) Spark Plug Boot Removal	L	33.28 mm (1.31 in.) Spark Plug Removal
M	32.22 mm (1.27 in.) Spark Plug Boot	N	37°	O	381.05 mm (15.00 in.) Spark Plug Removal	P	389.59 mm (15.34 in.) Spark Plug Boot Removal
Q	Mounting Hole "A"	R	106.0 mm (4.17 in.)	S	232.0 mm (9.13 in.)	T	8 X Ø 10.7 mm (0.42 in.) Thru Mounting Holes
U	Engine Mounting Surface	V	Center Line Engine	W	572.48 mm (22.54 in.) Lifting Point	X	32.7 mm (1.29 in.) Spark Plug Boot
Y	34.62 mm (1.36 in.) Spark Plug Removal	Z	69.97 mm (2.76 in.) Spark Plug Boot Removal	AA	Mechanical Fuel Pump	AB	Lifting Point

Specifications

Engine Dimensions with Heavy-Duty Air Cleaner - PTO Side

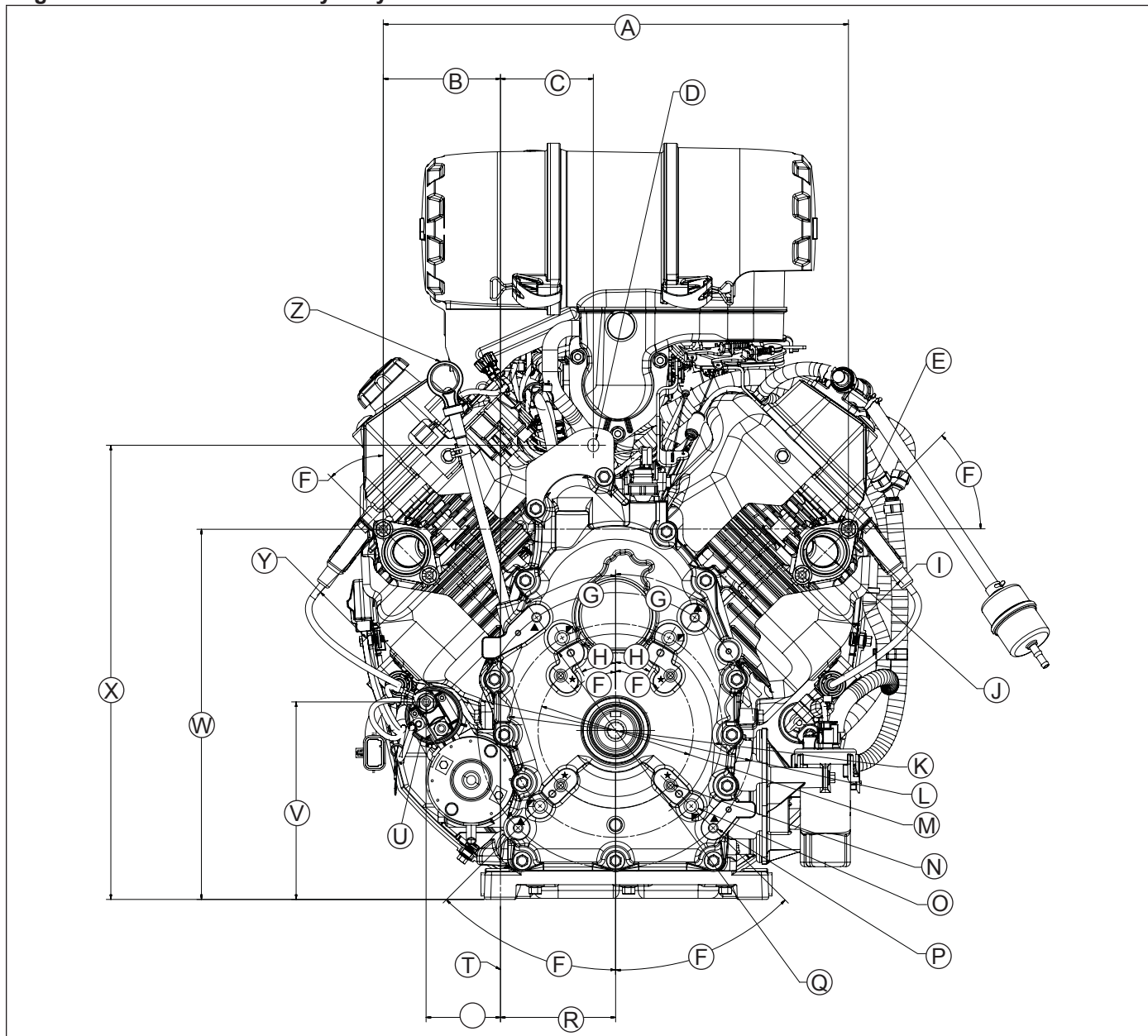

A	428.2 mm (16.86 in.)	B	S 107.9 mm (4.25 in.)	C	85.47 mm (3.37 in.) Lifting Point	D	Lifting Point
E	M8 X 1.25 mm 4 Studs	F	45°	G	35°	H	30°
I	60.0 mm (2.36 in.) Exhaust Port #2	J	2 X Ø 35.0 mm (1.38 in.) Gasket	K	Ø 196.85 mm (7.75 in.) B.C.	L	Ø 254.0 mm (10.0 in.) B.C.
M	Ø 142.88 mm (5.63 in.) B.C.	N	4 X 3/8-16 UNC-2B in. 21 mm (0.83 in.) Deep	O	4 X 7/16-14 UNC-2B in. 21 mm (0.83 in.) Deep	P	M8 X 1.25 mm-6H in. 25 mm (0.98 in.) Deep
Q	Ø 177.8 mm (7.00 in.) Pilot	R	106.0 mm (4.17 in.)	S	232.0 mm (9.13 in.)	T	Mounting Hole "A"
U	Solenoid Shift Starter	V	181.9 mm (7.16 in.) Starter Stud	W	340.9 mm (13.42 in.)	X	418.2 mm (16.47 in.) Lifting Point
Y	60.0 mm (2.36 in.) Exhaust Port #1	Z	Oil Level Dipstick				

Engine Dimensions with Heavy-Duty Air Cleaner - Starter Side

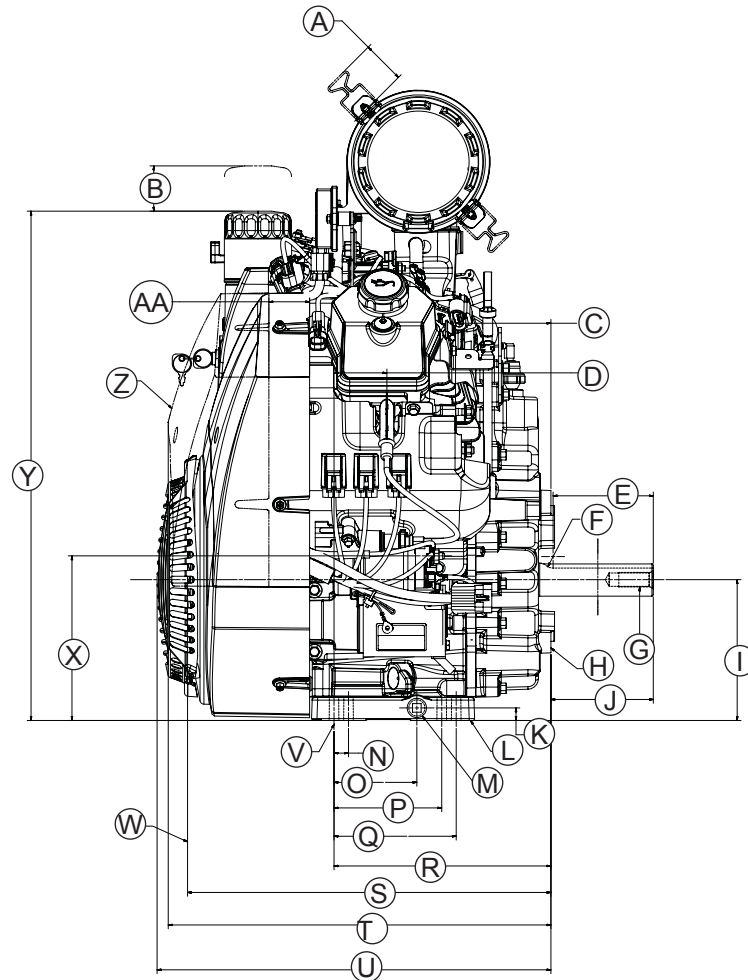

A	4 X 47.3 mm (1.86 in.) Air Cleaner Clip Clearance	B	50.0 mm (1.97 in.) Oil Filter Removal	C	105.4 mm (4.15 in.) Exhaust Port #1	D	58.4 mm (2.30 in.) Center Line Spark Plug
E	110.7 mm (4.36 in.)	F	12.7 mm (0.50 in.)	G	38.1 mm (1.5 in.) Deep 5/8-18 UNF-2B in.	H	PTO Mounting Surface
I	155.6 mm (6.13 in.)	J	113.1 mm (4.45 in.)	K	13.88 mm (0.55 in.)	L	Engine Mounting Surface
M	Oil Drain Plug 1/2 NPT Inch	N	16.0 mm (0.63 in.)	O	91.5 mm (3.60 in.)	P	119.0 mm (4.69 in.)
Q	135.0 mm (5.32 in.)	R	239.6 mm (9.44 in.)	S	401.5 mm (15.81 in.)	T	422.8 mm (16.65 in.) Cylinder #1 Shroud Removal
U	435.1 mm (17.13 in.)	V	Mounting Hole "A"	W	Grass Screen	X	181.9 mm (7.16 in.) Starter Stud
Y	562.7 mm (22.16 in.)	Z	Cylinder #1 Shroud	AA	45.0 mm (1.77 in.) Cylinder #1 Shroud Removal		

Specifications

Engine Dimensions with Heavy-Duty Air Cleaner - Opposite Starter Side

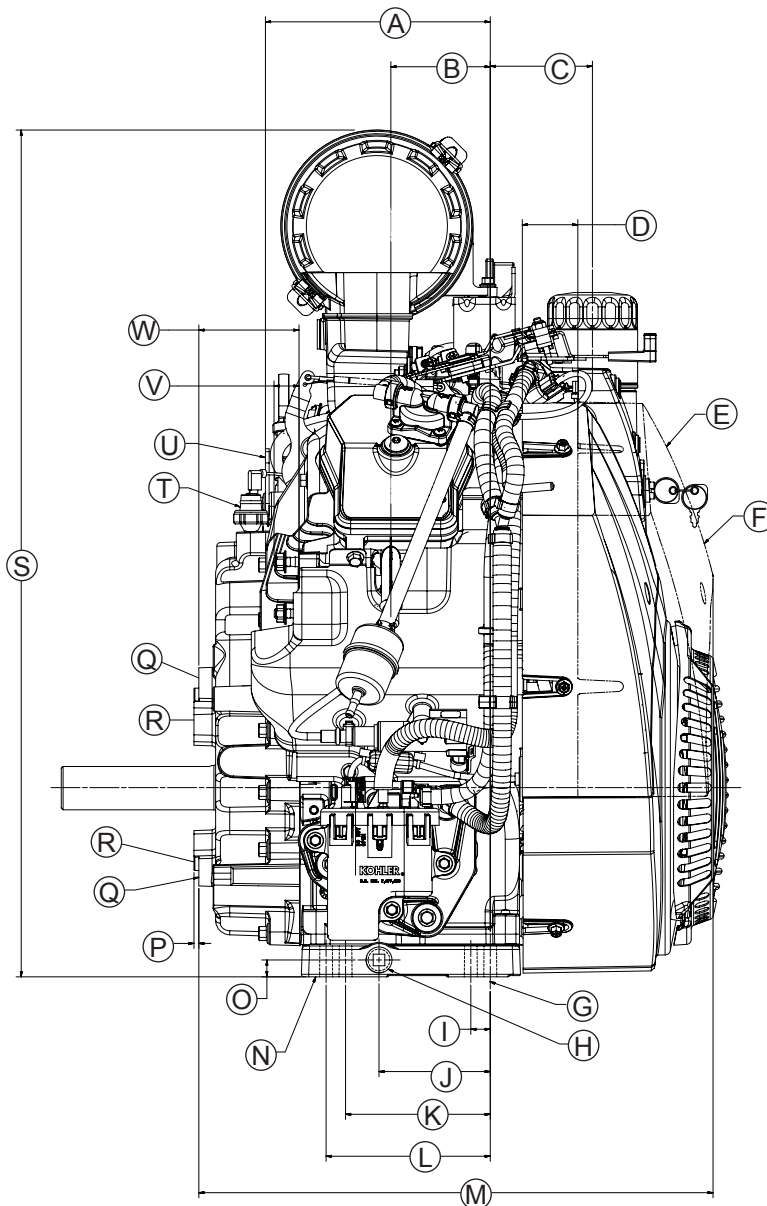

A	184.9 mm (7.28 in.)	B	81.8 mm (3.22 in.) Center Line Spark Plug	C	84.0 mm (3.31 in.) Oil Filter	D	45.6 mm (1.80 in.) Cylinder #2 Shroud Removal
E	Cylinder #2 Shroud	F	Access to Oil Cooler	G	Mounting Hole "A"	H	Oil Drain Plug 1/2 NPT Inch
I	16.0 mm (0.63 in.)	J	91.5 mm (3.60 in.)	K	119.0 mm (4.69 in.)	L	135.0 mm (5.32 in.)
M	422.8 mm (16.65 in.) Cylinder #2 Shroud Removal	N	Engine Mounting Surface	O	13.88 mm (0.55 in.)	P	4 X 4.0 mm (0.16 in.) Pilot Height
Q	PTO Mounting Surface	R	Pilot Surface	S	696.3 mm (27.41 in.)	T	Oil Pressure Switch
U	Lifting Point	V	4 X 20.6 mm (0.81in.) Muffler Mounting Stud Height	W	82.4 mm (3.24 in.) Exhaust Port #2		

Engine Dimensions with Low-Profile Air Cleaner - Flywheel Side

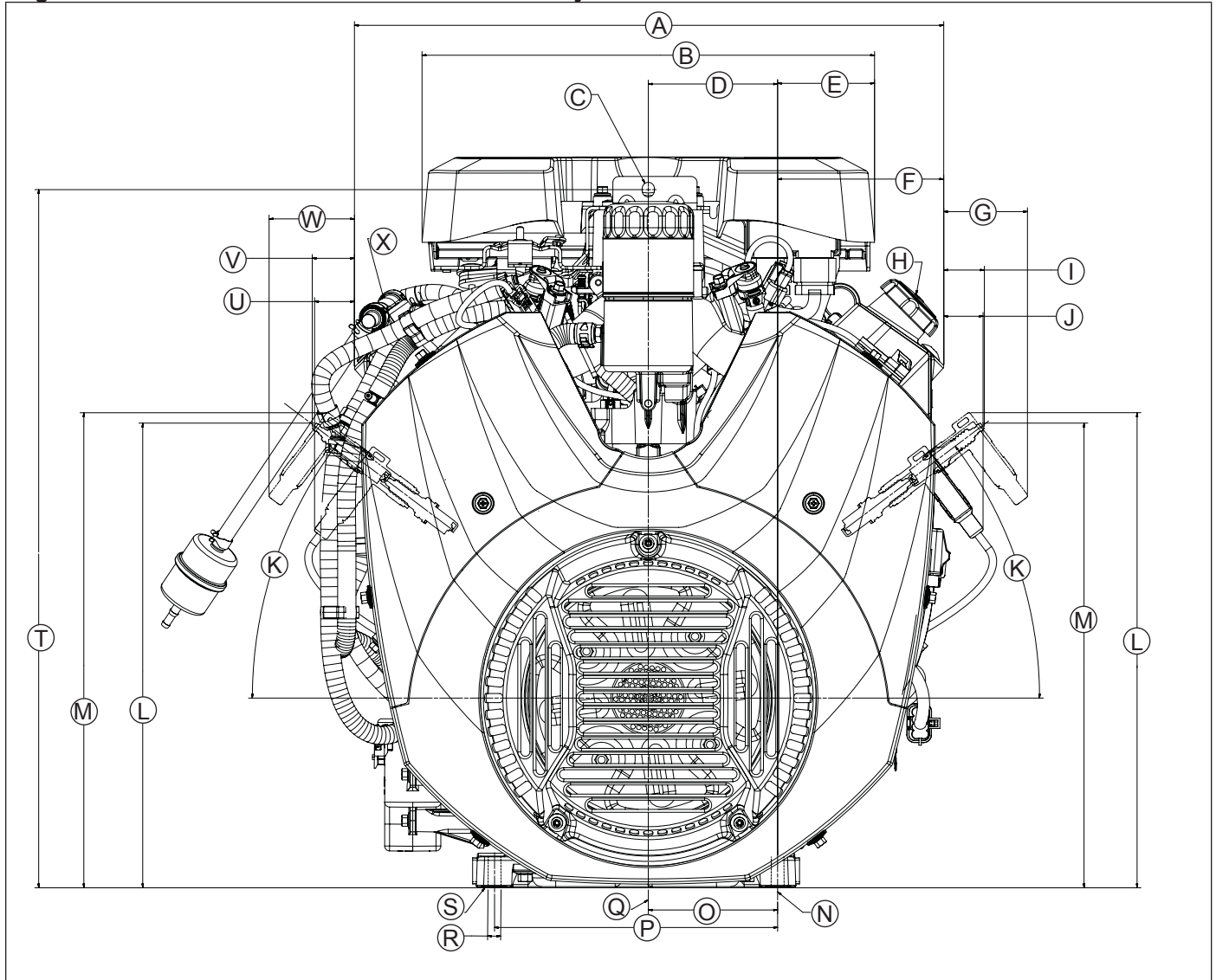

A	483.0 mm (19.02 in.)	B	370.9 mm (14.60 in.)	C	Lifting Point	D	106.0 mm (4.17 in.) Lifting Point
E	79.5 mm (3.13 in.)	F	136.2 mm (5.36 in.)	G	68.6 mm (2.70 in.) Spark Plug Boot Removal	H	Oil Fill
I	33.3 mm (1.31 in.) Spark Plug Removal	J	32.2 mm (1.27 in.) Spark Plug Boot	K	37°	L	389.6 mm (15.34 in.) Spark Plug Boot Removal
M	381.1 mm (15.00 in.) Spark Plug Removal	N	Mounting Hole "A"	O	106.0 mm (4.17 in.)	P	232.0 mm (9.13 in.)
Q	Center Line Engine	R	8 X Ø 10.7 mm (0.42 in.) Thru Mounting Holes	S	Engine Mounting Surface	T	572.5 mm (22.54 in.) Lifting Point
U	32.7 mm (1.29 in.) Spark Plug Boot	V	34.6 mm (1.36 in.) Spark Plug Removal	W	70.0 mm (2.76 in.) Spark Plug Boot Removal	X	Mechanical Fuel Pump

Specifications

Engine Dimensions with Low-Profile Air Cleaner - PTO Side

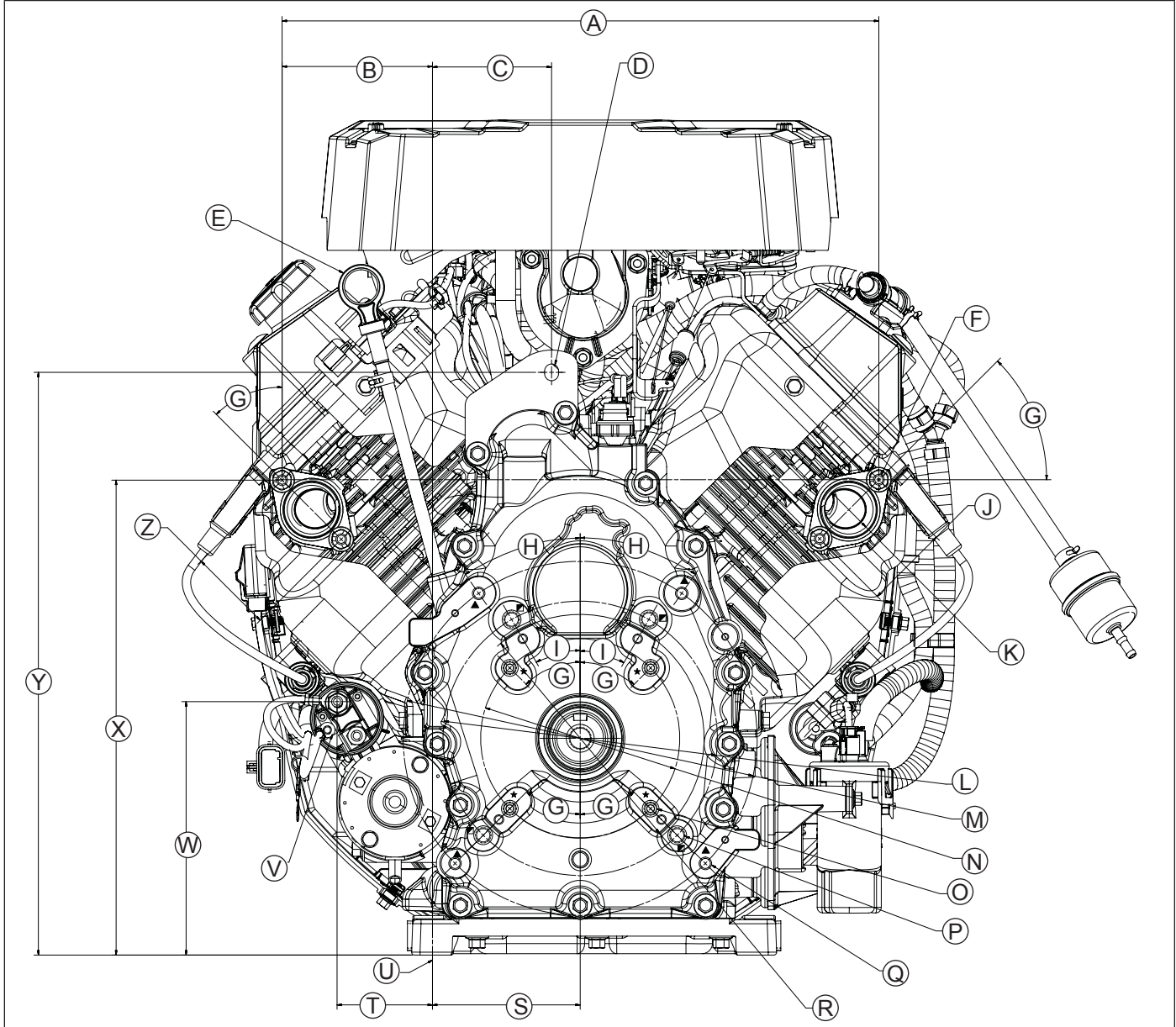

A	428.2 mm (16.86 in.)	B	107.9 mm (4.25 in.)	C	85.5 mm (3.37 in.) Lifting Point	D	Lifting Point
E	Oil Level Dipstick	F	M8 X 1.25 mm 4 Studs	G	45°	H	35°
I	30°	J	60.0 mm (2.37 in.) Exhaust Port #2	K	2 X Ø 35.0 mm (1.38 in.) Gasket	L	Ø 196.85 mm (7.75 in.) B.C.
M	Ø 254.0 mm (10.0 in.) B.C.	N	Ø 142.9 mm (5.63 in.) B.C.	O	4 X 3/8-16 UNC-2B in. 21 mm (0.83 in.) Deep	P	4 X 7/16-14 UNC-2B in. 21 mm (0.83 in.) Deep
Q	4 X M8 X 1.25 mm-6H in. 25 mm (0.98 in.) Deep	R	Ø 177.8 mm (7.00 in.) Pilot	S	106.0 mm (4.17 in.)	T	68.5 mm (2.70 in.) Starter Stud
U	Mounting Hole "A"	V	Solenoid Shift Starter	W	181.9 mm (7.16 in.) Starter Stud	X	340.9 mm (13.42 in.)
Y	418.2 mm (16.47 in.) Lifting Point	Z	60.0 mm (2.36 in.) Exhaust Port #1				

Engine Dimensions with Low-Profile Air Cleaner - Starter Side

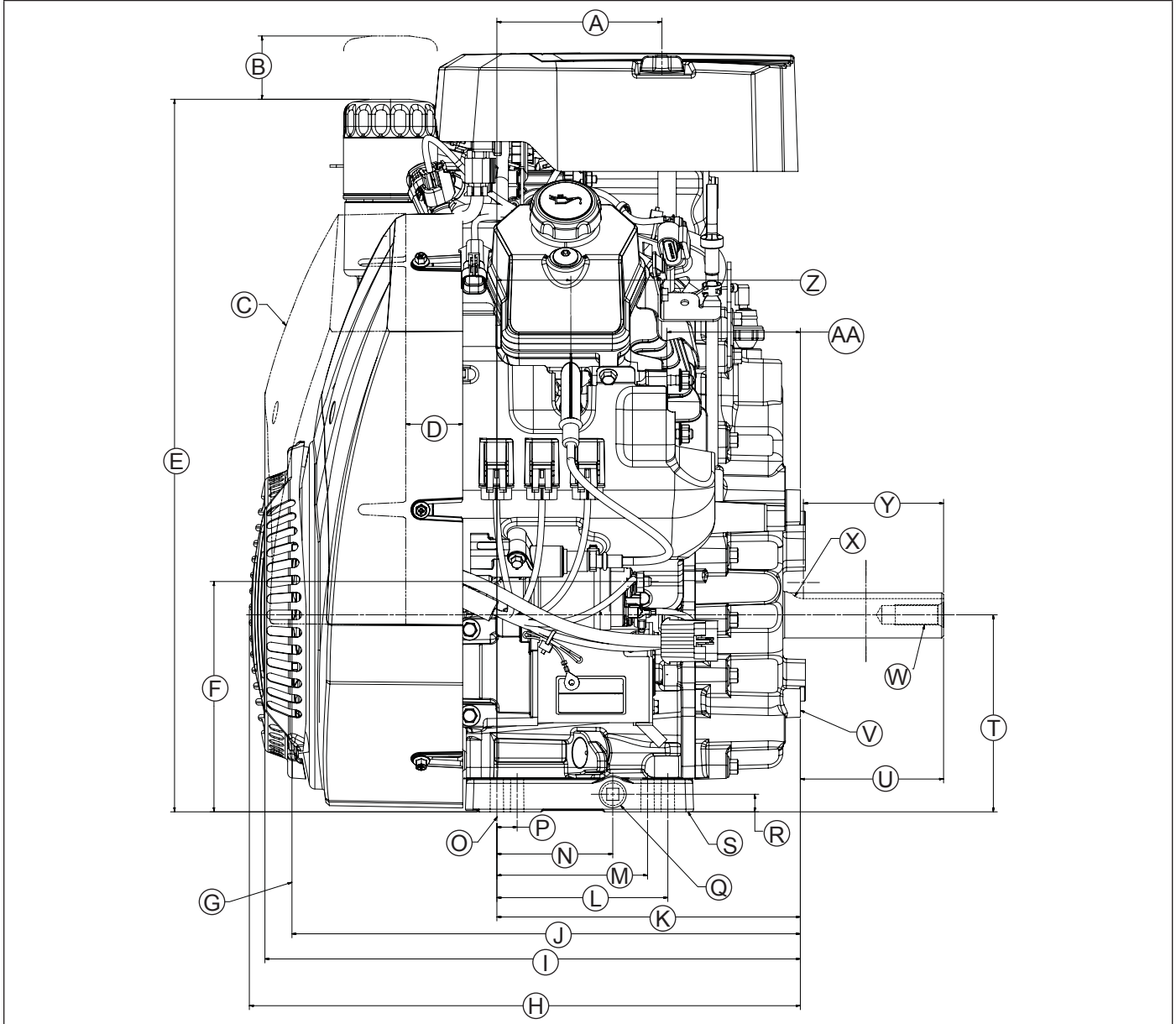

A	130.4 mm (5.13 in.)	B	50.0 mm (1.97 in.) Oil Filter Removal	C	Cylinder #1 Shroud	D	45.0 mm (1.77 in.) Cylinder #1 Shroud Removal
E	562.7 mm (22.16 in.)	F	181.9 mm (7.16 in.) Starter Stud	G	Grass Screen	H	435.13 mm (17.13 in.)
I	422.8 mm (16.65 in.) Cylinder #1 Shroud Removal	J	401.5 mm (15.81 in.)	K	239.6 mm (9.44 in.)	L	135.0 mm (5.32 in.)
M	119.0 mm (4.69 in.)	N	91.5 mm (3.6 in.)	O	Mounting Hole "A"	P	16.0 mm (0.63 in.)
Q	Oil Drain Plug 1/2 NPT Inch	R	Engine Mounting Surface	S	13.88 mm (0.55 in.)	T	155.6 mm (6.13 in.)
U	113.1 mm (4.45 in.)	V	PTO Mounting Surface	W	5/8-18 UNF-2B in. 38.1 mm (1.5 in.) Deep	X	12.7 mm (0.50 in.)
Y	110.7 mm (4.36 in.)	Z	58.4 mm (2.30 in.) Center Line Spark Plug	AA	105.4 mm (4.15 in.) Exhaust Port #1		

Specifications

Engine Dimensions with Low-Profile Air Cleaner - Opposite Starter Side

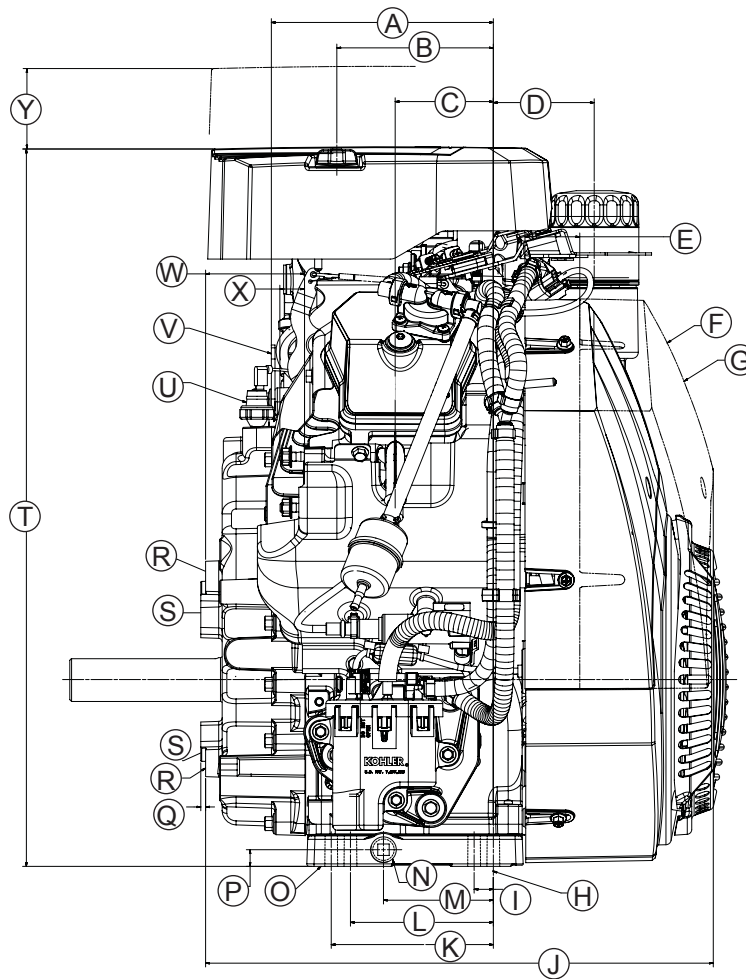

A	184.9 mm (7.28 in.)	B	130.4 mm (5.13 in.)	C	81.8 mm (3.22 in.) Center Line Spark Plug	D	84.0 mm (3.31 in.) Oil Filter
E	45.6 mm (1.80 in.) Cylinder #2 Shroud Removal	F	Cylinder #2 Shroud	G	Access to Integrated Oil Cooler	H	Mounting Hole "A"
I	16.0 mm (0.63 in.)	J	422.8 mm (16.65 in.) Cylinder #2 Shroud Removal	K	135.0 mm (5.32 in.)	L	119.0 mm (4.69 in.)
M	91.5 mm (3.60 in.)	N	Oil Drain Plug 1/2 NPT Inch	O	Engine Mounting Surface	P	13.88 mm (0.55 in.)
Q	4 X 4.0 mm (0.16 in.) Pilot Height	R	PTO Mounting Surface	S	Pilot Surface	T	597.5 mm (23.52 in.)
U	Oil Pressure Switch	V	Lifting Point	W	82.4 mm (3.24 in.) Exhaust Port #2	X	4 X 20.6 mm (0.81 in.) Muffler Mounting Stud Height
Y	67.0 mm (2.64 in.) Air Cleaner Cover Removal						

ENGINE IDENTIFICATION NUMBERS

Rehiko engine identification numbers (model, specification and serial) should be referenced for efficient repair, ordering correct parts, and engine replacement.

Model.....	ECH940	
EFI Command Engine		
Horizontal Shaft Numerical Designation		
Specification	ECH940-0001	
Serial	5023500328	
Year Manufactured Code	50	Factory Code
Code	Year	
50	2020	
51	2021	
52	2022	

GENERAL SPECIFICATIONS ^{3,4}	ECH940	ECH980
Bore	90 mm (3.54 in.)	
Stroke	78.5 mm (3.1 in.)	
Displacement	999 cc (61 cu. in.)	
Oil Capacity (refill)	1.9-2.6 L (2.0-2.7 U.S. qt.)	
Maximum Angle of Operation (@ full oil level) ⁵	25°	

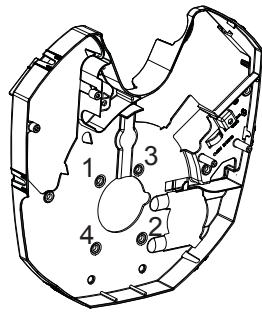
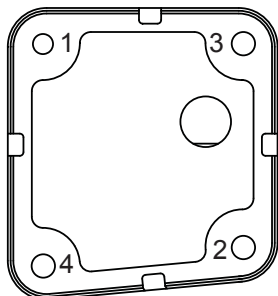
TORQUE SEQUENCES	ECH940	ECH980
(Refer to Torque Specifications for torque values).		
Backing Shroud Fasteners		
Breather Cover Fasteners		

³ Values are in Metric units. Values in parentheses are English equivalents.

⁴ Any and all horsepower (hp) references by Rehiko are Certified Power Ratings and per SAE J1940 & J1995 hp standards. Details on Certified Power Ratings can be found at

⁵ Exceeding maximum angle of operation may cause engine damage from insufficient lubrication.

Specifications

TORQUE SEQUENCES

ECH940

ECH980

(Refer to Torque Specifications for torque values).

<p>Cylinder Head Bolt Fasteners</p>	
<p>Intake Manifold Mounting Fasteners</p>	
<p>Closure Plate Fasteners</p>	
<p>Oil Reservoir Fasteners</p>	

TORQUE SPECIFICATIONS^{3,6}

ECH940

ECH980

Backing Shroud (torque sequence on page 13)

Backing Shroud to Crankcase	10.7 N·m (95 in. lb.) into new holes 7.3 N·m (65 in. lb.) into used holes
-----------------------------	--

Blower Housing and Sheet Metal

M6 Screw	
New, Untapped Hole (casting)	10.7 N·m (95 in. lb.)
Used, Tapped Hole (casting)	7.3 N·m (65 in. lb.)
New, Extruded Hole (sheet metal)	2.5 N·m (22 in. lb.)
Used, Extruded Hole (sheet metal)	2.0 N·m (18 in. lb.)
Mounting Clip (valley baffle)	2.5 N·m (22 in. lb.)

Closure Plate (torque sequence on page 14)

Closure Plate Fastener	25.6 N·m (227 in. lb.)
------------------------	------------------------

Connecting Rod

Cap Fastener (torque in increments)	11.6 N·m (103 in. lb.)
-------------------------------------	------------------------

Control Bracket

Mounting Screw (into baffle)	10.2 N·m (90 in. lb.)
------------------------------	-----------------------

Control Panel

Key Switch to Control Panel Nut	1.6 N·m (14 in. lb.)
Mounting Screw (into intake manifold)	11.3 N·m (100 in. lb.)
Mounting Screw (into oil filter housing)	11.3 N·m (100 in. lb.)

Crankcase

Breather Cover Fastener (torque sequence on page 13)	12.4 N·m (110 in. lb.)
Engine (oil) Temperature Sensor	7.3 N·m (65 in. lb.)
Oil Sentry™	10.7 N·m (95 in. lb.)
Oil Drain Plug	21.4 N·m (16 ft. lb.)

Cylinder Head (torque sequence on page 14)

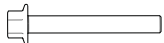
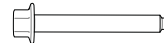
Cylinder Head Fastener (torque in 2 increments) Head Bolt	first to 23.7 N·m (210 in. lb.) finally to 46.9 N·m (415 in. lb.)
Pipe Plug (3/4 in.)	28.5 N·m (252 in. lb.)
Rocker Arm Screw	
	15.5 N·m (137 in. lb.)
	11.9 N·m (105 in. lb.)

Debris Screen/Fan/Flywheel

Debris Screen Fastener	9.9 N·m (88 in. lb.)
Flywheel Retaining Screw	69.8 N·m (51 in. lb.)
Front Drive Shaft Fastener	24.4 N·m (216 in. lb.)

Fuel Pump Module

Fuel Pump Module Baffle Fastener	11.3 N·m (100 in. lb.)
Fuel Pump Module Fastener	9.2 N·m (81 in. lb.)

³ Values are in Metric units. Values in parentheses are English equivalents.

⁶ Lubricate threads with engine oil prior to assembly.

Specifications

TORQUE SPECIFICATIONS^{3,6}

ECH940

ECH980

Fuse Holder Bracket

Fuse Holder Bracket to Cylinder Head Fastener	10.7 N·m (95 in. lb.) into new holes 7.3 N·m (65 in. lb.) into used holes
---	--

Governor

Governor Lever Nut	7.1 N·m (63 in. lb.)
Governor Yoke Mounting Screw	2.2 N·m (20 in. lb.)

Ignition

Ignition Coil Fastener	5.1 N·m (45 in. lb.)
Electronic Control Unit Isolation Mount Nut	2.0 N·m (18 in. lb.)
Crankshaft Position Sensor to Bracket Screw	11.3 N·m (100 in. lb.)
Crankshaft Position Sensor Bracket to Crankcase Screw	9.9 N·m (88 in. lb.)
Spark Plug	27 N·m (20 ft. lb.)
Rectifier-Regulator Fastener	2.5 N·m (22 in. lb.)
Rectifier-Regulator Ground Lead Fastener to Ground Lug/Backing Shroud	5.6 N·m (50 in. lb.) into new holes 4.0 N·m (35 in. lb.) into used holes
Wire Harness Clamp and Ground Eyelets Fastener	2.5 N·m (22 in. lb.) into new holes 2.0 N·m (18 in. lb.) into used holes

Intake Manifold (torque sequence on page 14)

Intake Manifold to Cylinder Head Mounting Fastener (torque in 2 increments)	first to 16.9 N·m (150 in. lb.) finally to 22.6 N·m (200 in. lb.)
Temperature/Manifold Absolute Pressure (TMAP) Sensor Fastener	7.3 N·m (65 in. lb.)
Air Cleaner to Throttle Body Fastener Nut	8.2 N·m (73 in. lb.)
Air Cleaner to Control Bracket Fastener	7.3 N·m (65 in. lb.)

Lifter Feed Chamber

Cover Screw	7.7 N·m (68 in. lb.)
-------------	----------------------

Muffler

Oxygen Sensor	50.1 N·m (37 ft. lb.)
Retaining Nut	24.4 N·m (216 in. lb.)
M6 Screw	9.9 N·m (88 in. lb.)
M8 Screw	24.4 N·m (216 in. lb.)

Oil Cooler

Mounting Screws	2.3 N·m (21 in. lb.)
-----------------	----------------------

Oil Filter Housing Assembly

Housing Assembly Mounting Screw	23.7 N·m (210 in. lb.)
Oil Filter Nipple	17.8 N·m (158 in. lb.)

Oil Pickup Screen

Mounting Screw	9.3 N·m (82 in. lb.) into new holes 7.7 N·m (68 in. lb.) into used holes
----------------	---

Oil Pickup Tube

Mounting Screw	11.3 N·m (100 in. lb.) into new holes 7.7 N·m (68 in. lb.) into used holes
----------------	---

³ Values are in Metric units. Values in parentheses are English equivalents.

⁶ Lubricate threads with engine oil prior to assembly.

Specifications

TORQUE SPECIFICATIONS ^{3,6}		ECH940	ECH980
Oil Pump			
Mounting Screw		9.9 N·m (88 in. lb.)	
Reservoir (oil) (torque sequence on page 14)			
Mounting Screw		25.6 N·m (227 in. lb.)	
Starter Assembly			
Mounting Screw		16.0 N·m (142 in. lb.)	
Stator			
Mounting Screw		9.3 N·m (82 in. lb.)	
Valve Cover			
Aluminum Valve Cover Fastener Into New Head		Torque screw to 26 N·m (230 in. lb.) to ensure seal seats in valve cover groove. Back off screw to zero and then torque screw again to 18.1 N·m (160 in. lb.).	
Into Used Head		Torque screw to 16.4 N·m (145 in. lb.) to ensure seal seats in valve cover groove. Back off screw to zero and then torque screw again to 16.4 N·m (145 in. lb.).	
Plastic Valve Cover Fastener		13.6 N·m (120 in. lb.)	

CLEARANCE SPECIFICATIONS ₃		ECH940	ECH980
Camshaft			
End Play		0.3/1.3 mm (0.011/0.051 in.)	
Running Clearance		0.025/0.063 mm (0.0010/0.0025 in.)	
Bore I.D.	New Max. Wear Limit	20.000/20.025 mm (0.7874/0.7884 in.) 20.038 mm (0.7889 in.)	
Bearing Surface O.D.	New Max. Wear Limit	19.962/19.975 mm (0.7859/0.7864 in.) 19.959 mm (0.7858 in.)	
Cam Lobe Profile (minimum dimension, measured from base circle to top of lobe) Exhaust		35 mm (1.3779 in.)	
Intake		35 mm (1.3779 in.)	
Connecting Rod			
Crankpin End I.D. @ 70°F	New Max. Wear Limit	44.030/44.037 mm (1.7334/1.7337 in.) 0.070 mm (0.0028 in.)	
Connecting Rod-to-Crankpin Running Clearance	New Max. Wear Limit	0.030/0.055 mm (0.0012/0.0022 in.) 0.070 mm (0.0028 in.)	
Connecting Rod-to-Crankpin Side Clearance		0.30/0.59 mm (0.0118/0.0232 in.)	
Connecting Rod-to-Piston Pin Running Clearance		0.015/0.028 mm (0.0006/0.0011 in.)	
Piston Pin End I.D. @ 70°F	New Max. Wear Limit	19.023/19.015 mm (0.7489/0.7486 in.) 19.036 mm (0.7494 in.)	

³ Values are in Metric units. Values in parentheses are English equivalents.

⁶ Lubricate threads with engine oil prior to assembly.

Specifications

CLEARANCE SPECIFICATIONS³

ECH940

ECH980

Crankcase

Governor Cross Shaft Bore I.D. New Max. Wear Limit	8.025/8.050 mm (0.3159/0.3169 in.) 8.088 mm (0.3184 in.)
--	---

Crankshaft

End Play (free) Non-Thrust Bearing	0.20/0.94 mm (0.008/0.037 in.)
Crankshaft Bore (in crankcase) New, Without Main Bearing With Main Bearing Installed Max. Wear Limit	50.00/50.025 mm (1.9685/1.969 in.) 45.040/45.145 mm (1.7732/1.7773 in.) 45.158 mm (1.7778 in.)
Crankshaft to Sleeve Bearing (in crankcase) Running Clearance New	0.040/0.167 mm (0.0015/0.0065 in.)
Crankshaft Bore (in closure plate) New, Without Bearing	50.025/50.00 mm (1.9694/1.9685 in.)
Crankshaft to Sleeve Bearing (in closure plate) Running Clearance New	0.040/0.167 mm (0.0015/0.0065 in.)
Closure Plate End Main Bearing Journal O.D. - New O.D. - Max. Wear Limit Max. Taper Max. Out-of-Round	44.978/45.00 mm (1.770/1.771 in.) 44.90 mm (1.767 in.) 0.022 mm (0.0009 in.) 0.025 mm (0.0010 in.)
Connecting Rod Journal O.D. - New O.D. - Max. Wear Limit Max. Taper Max. Out-of-Round Width	43.982/44.000 mm (1.731/1.732 in.) 43.97 mm (1.731 in.) 0.018 mm (0.0007 in.) 0.025 mm (0.0010 in.) 53.00/53.09 mm (2.0866/2.0901 in.)
Crankshaft T.I.R. PTO End, Crank in Engine Entire Crank, in V-Blocks	0.279 mm (0.0110 in.) 0.10 mm (0.0039 in.)
Flywheel End Main Bearing Journal O.D. - New O.D. - Max. Wear Limit Max. Taper Max. Out-of-Round	44.978/45.00 mm (1.770/1.771 in.) 44.90 mm (1.767 in.) 0.022 mm (0.0009 in.) 0.025 mm (0.0010 in.)

Cylinder Bore

Cylinder Bore I.D. New Max. Wear Limit Max. Taper Max. Out-of-Round	90.000/90.025 mm (3.543/3.544 in.) 90.075 mm (3.546 in.) 0.013 mm (0.00051 in.) 0.013 mm (0.00051 in.)
---	---

Cylinder Head

Max. Out-of-Flatness	0.076 mm (0.003 in.)
----------------------	----------------------

Governor

Governor Cross Shaft-to-Crankcase Running Clearance	0.025/0.087 mm (0.0009/0.0034 in.)
Governor Cross Shaft O.D. New Max. Wear Limit	7.963/8.000 mm (0.3135/0.3149 in.) 7.936 mm (0.3124 in.)
Governor Gear Shaft-to-Governor Gear Running Clearance	0.070/0.160 mm (0.0027/0.0063 in.)
Governor Gear Shaft O.D. New Max. Wear Limit	5.990/6.000 mm (0.2358/0.2362 in.) 5.977 mm (0.2353 in.)

³ Values are in Metric units. Values in parentheses are English equivalents.

Specifications



CLEARANCE SPECIFICATIONS ³	ECH940	ECH980
Ignition		
Spark Plug Gap	0.76 mm (0.030 in.)	
Crankshaft Bearing (flywheel/PTO)		
New (installed)	45.040/45.145 mm (1.773/1.777 in.)	
Max. Wear Limit	45.158 mm	
Piston, Piston Rings, and Piston Pin		
Piston-to-Piston Pin Running Clearance	0.006/0.017 mm (0.0002/0.0007 in.)	
Piston Pin Bore I.D. New Max. Wear Limit	20.006/20.012 mm (0.7876/0.7879 in.) 20.025 mm (0.7884 in.)	
Piston Pin O.D. New Max. Wear Limit	19.995/20.000 mm (0.7872/0.7874 in.) 19.994 mm (0.7872 in.)	
Top Compression Ring-to-Groove Side Clearance	0.030/0.070 mm (0.001/0.0026 in.)	
Middle Compression Ring-to-Groove Side Clearance	0.030/0.070 mm (0.001/0.0026 in.)	
Oil Control Ring-to-Groove Side Clearance	0.060/0.190 mm (0.0022/0.0073 in.)	
Top Compression Ring End Gap New Max. Wear Limit	0.125/0.304 mm (0.0049/0.0120 in.) 0.515 mm (0.0203 in.)	
Middle Compression Ring End Gap New Max. Wear Limit	0.900/1.179 mm (0.0354/0.0464 in.) 1.432 mm (0.0564 in.)	
Piston Thrust Face O.D. ⁷ New Bore Used Bore (max.)	89.972 mm (3.5422 in.) 89.827 mm (3.5365 in.)	
Piston Thrust Face-to-Cylinder Bore ⁷ Running Clearance New	0.021/0.060 mm (0.0008/0.00236 in.)	
Valves and Valve Lifters		
Hydraulic Valve Lifter to Crankcase Running Clearance	0.012/0.050 mm (0.0004/0.0019 in.)	
Intake Valve Stem-to-Valve Guide Running Clearance	0.038/0.076 mm (0.0015/0.0030 in.)	
Exhaust Valve Stem-to-Valve Guide Running Clearance	0.050/0.088 mm (0.0020/0.0035 in.)	
Intake Valve Guide I.D. New Max. Wear Limit	7.038/7.058 mm (0.2771/0.2779 in.) 7.135 mm (0.2809 in.)	
Exhaust Valve Guide I.D. New Max. Wear Limit	7.038/7.058 mm (0.2771/0.2779 in.) 7.159 mm (0.2819 in.)	
Valve Guide Reamer Size Standard 0.25 mm O.S.	7.048 mm (0.2775 in.) 7.298 mm (0.2873 in.)	
Nominal Valve Face Angle	45°	

³ Values are in Metric units. Values in parentheses are English equivalents.





⁷ Measure 11 mm (0.4331 in.) above bottom of piston skirt at right angles to piston pin.

Specifications

GENERAL TORQUE VALUES

English Fastener Torque Recommendations for Standard Applications				
Bolts, Screws, Nuts and Fasteners Assembled Into Cast Iron or Steel				Grade 2 or 5 Fasteners Into Aluminum
Size	 Grade 2	 Grade 5	 Grade 8	
Tightening Torque: N·m (in. lb.) ± 20%				
8-32	2.3 (20)	2.8 (25)	—	2.3 (20)
10-24	3.6 (32)	4.5 (40)	—	3.6 (32)
10-32	3.6 (32)	4.5 (40)	—	—
1/4-20	7.9 (70)	13.0 (115)	18.7 (165)	7.9 (70)
1/4-28	9.6 (85)	15.8 (140)	22.6 (200)	—
5/16-18	17.0 (150)	28.3 (250)	39.6 (350)	17.0 (150)
5/16-24	18.7 (165)	30.5 (270)	—	—
3/8-16	29.4 (260)	—	—	—
3/8-24	33.9 (300)	—	—	—

Tightening Torque: N·m (ft. lb.) ± 20%				
5/16-24	—	—	40.7 (30)	—
3/8-16	—	47.5 (35)	67.8 (50)	—
3/8-24	—	54.2 (40)	81.4 (60)	—
7/16-14	47.5 (35)	74.6 (55)	108.5 (80)	—
7/16-20	61.0 (45)	101.7 (75)	142.5 (105)	—
1/2-13	67.8 (50)	108.5 (80)	155.9 (115)	—
1/2-20	94.9 (70)	142.4 (105)	223.7 (165)	—
9/16-12	101.7 (75)	169.5 (125)	237.3 (175)	—
9/16-18	135.6 (100)	223.7 (165)	311.9 (230)	—
5/8-11	149.5 (110)	244.1 (180)	352.6 (260)	—
5/8-18	189.8 (140)	311.9 (230)	447.5 (330)	—
3/4-10	199.3 (147)	332.2 (245)	474.6 (350)	—
3/4-16	271.2 (200)	440.7 (325)	637.3 (470)	—

Metric Fastener Torque Recommendations for Standard Applications						
Size	Property Class					Noncritical Fasteners Into Aluminum
	 4.8	 5.8	 8.8	 10.9	 12.9	
Tightening Torque: N·m (in. lb.) ± 10%						
M4	1.2 (11)	1.7 (15)	2.9 (26)	4.1 (36)	5.0 (44)	2.0 (18)
M5	2.5 (22)	3.2 (28)	5.8 (51)	8.1 (72)	9.7 (86)	4.0 (35)
M6	4.3 (38)	5.7 (50)	9.9 (88)	14.0 (124)	16.5 (146)	6.8 (60)
M8	10.5 (93)	13.6 (120)	24.4 (216)	33.9 (300)	40.7 (360)	17.0 (150)
Tightening Torque: N·m (ft. lb.) ± 10%						
M10	21.7 (16)	27.1 (20)	47.5 (35)	66.4 (49)	81.4 (60)	33.9 (25)
M12	36.6 (27)	47.5 (35)	82.7 (61)	116.6 (86)	139.7 (103)	61.0 (45)
M14	58.3 (43)	76.4 (56)	131.5 (97)	184.4 (136)	219.7 (162)	94.9 (70)

Torque Conversions	
N·m = in. lb. x 0.113	in. lb. = N·m x 8.85
N·m = ft. lb. x 1.356	ft. lb. = N·m x 0.737

Certain quality tools are designed to help you perform specific disassembly, repair, and reassembly procedures. By using these tools, you can properly service engines easier, faster, and safer! In addition, you'll increase your service capabilities and customer satisfaction by decreasing engine downtime.

Here is a list of tools and their source.

NOTE: Not all tools listed are required to service this engine.

SEPARATE TOOL SUPPLIERS

Rehiko Tools
Contact your local Rehiko source of supply.

SE Tools 415 Howard
St. Lapeer, MI 48446
Phone 810-664-2981
Toll Free 800-664-2981
Fax 810-664-8181
Design Technology Inc.

768 Burr Oak Drive
Westmont, IL 60559
Phone 630-920-1300
Fax 630-920-0011

TOOLS

Description	Source/Part No.
Alcohol Content Tester For testing alcohol content (%) in reformulated/oxygenated fuels.	Rehiko 25 455 11-S
Camshaft Endplay Plate For checking camshaft endplay.	SE Tools KLR-82405
Camshaft Seal Protector (Aegis) For protecting seal during camshaft installation.	SE Tools KLR-82417
Dual Gauge Cylinder Leakdown Tester For checking combustion retention and if cylinder, piston, rings, or valves are worn. Individual component available: Adapter 12 mm x 14 mm (Required for leakdown test on XT-6 engines)	Rehiko 25 761 46-S Design Technology Inc. DTI-731-03
Dealer Tool Kit Complete kit of Rehiko required tools. Components of 25 761 39-S Ignition System Tester Dual Gauge Cylinder Leakdown Test Tool Oil Pressure Test Kit Digital Vacuum/Pressure Tester	Rehiko 25 761 39-S Rehiko 25 455 01-S Rehiko 25 761 46-S Rehiko 25 761 06-S Rehiko 25 455 22-S
Digital Vacuum/Pressure Tester For checking crankcase vacuum. Individual component available: Rubber Adapter Plug	Rehiko 25 455 22-S Design Technology Inc. DTI-721-10
EFI Service Kit For troubleshooting and setting up an EFI engine. Components of 24 761 01-S Fuel Pressure Tester Noid Light 90° Adapter Code Plug, Red Wire Code Plug, Blue Wire Code Plug, Yellow Wire Can Bus Reset Tool, Green Wire Shrader Valve Adapter Hose Wire Probe Set (2 pieces regular wire with clip; 1 piece fused wire) Hose Removal Tool, Dual Size/End (also sold as individual Rehiko tool) K-Line Adapter Jumper Lead Wiring Harness	Rehiko 24 761 01-S Design Technology Inc. DTI-019 DTI-021 DTI-023 DTI-027 DTI-029 DTI-028 DTI-030 DTI-037 DTI-031 DTI-033 Rehiko 25 176 23-S
Rehiko[®] Diagnostic System (KDS) Gen 2 For Laptop or Desktop PC. Components of 25 761 50-S Engine Communication Module 7 Pin to DB9 Cable USB Module to PC Cable 7 Pin to 4 Pin Adapter	Rehiko 25 761 50-S Rehiko 25 761 47-S Rehiko 25 761 48-S Rehiko 25 761 49-S Rehiko 25 761 53-S
Mobile KDS (Wireless) Module For mobile Android or iOS EFI diagnostics. Individual component available: Wireless Diagnostic System Interface Cable	Rehiko 25 761 45-S Rehiko 25 761 44-S

Tools and Aids

TOOLS

Description	Source/Part No.
Flywheel Puller For properly removing flywheel from engine.	SE Tools KLR-82408
Flywheel Anchor Bolts, Washers, Nuts Tool Used with Flywheel Puller for properly removing flywheel from 5400 Series engine.	Rehiko 25 086 753-S
Hose Removal Tool, Dual Size/End (also available in EFI Service Kit) Used to properly remove fuel hose from engine components.	Rehiko 25 455 20-S
Ignition System Tester For testing output on all systems, including CD.	Rehiko 25 455 01-S
Inductive Tachometer (Digital) For checking operating speed (RPM) of an engine.	Design Technology Inc. DTI-110
Oil Pressure Test Kit For testing/verifying oil pressure on pressure lubricated engines.	Rehiko 25 761 06-S
Rectifier-Regulator Tester (120 volt current) Rectifier-Regulator Tester (240 volt current) For testing rectifier-regulators. Components of 25 761 20-S and 25 761 41-S CS-PRO Regulator Test Harness Special Regulator Test Harness with Diode	Rehiko 25 761 20-S Rehiko 25 761 41-S Design Technology Inc. DTI-031R DTI-033R
Spark Advance Module (SAM) Tester For testing SAM (ASAM and DSAM) on engines with SMART-SPARK™.	Rehiko 25 761 40-S
Starter Servicing Kit (All Starters) For removing and reinstalling drive retaining rings and brushes. Individual component available: Starter Brush Holding Tool (Solenoid Shift)	SE Tools KLR-82411 SE Tools KLR-82416
Stepper Motor Controller Tool For testing operation of stepper motor/Digital Linear Actuator (DLA).	Rehiko 25 455 21-S
Jumper Lead Tool For use with Stepper Motor Controller Tool to test rotary stepper motor.	Rehiko 25 518 43-S
Triad/OHC Timing Tool Set For holding cam gears and crankshaft in timed position while installing timing belt.	Rehiko 28 761 01-S
Valve Guide Reamer (K and M Series) For properly sizing valve guides after installation.	Design Technology Inc. DTI-K828
Valve Guide Reamer O.S. (Command Series) For reaming worn valve guides to accept replacement oversize valves. Can be used in low-speed drill press or with handle below for hand reaming.	Rehiko 25 455 12-S
Reamer Handle For hand reaming using Rehiko 25 455 12-S reamer.	Design Technology Inc. DTI-K830

AIDS

Description	Source/Part No.
Camshaft Lubricant (Valspar ZZ613)	Rehiko 25 357 14-S
Dielectric Grease	Loctite® 51360
Rehiko Electric Starter Drive Lubricant (Inertia Drive)	Rehiko 52 357 01-S
P80 Emulsion Lubricant	Rehiko 25 357 80-S
RTV Silicone Sealant Loctite® 5900® Heavy Body in 4 oz. aerosol dispenser. Only oxime-based, oil resistant RTV sealants, such as those listed, are approved for use. Permatex® the Right Stuff® 1 Minute Gasket™ or Loctite® Nos. 5900® or 5910® are recommended for best sealing characteristics.	Rehiko 25 597 07-S Loctite® 5910® Loctite® Ultra Black 598™ Loctite® Ultra Blue 587™ Loctite® Ultra Copper 5920™ Permatex® the Right Stuff® 1 Minute Gasket™
Spline Drive Lubricant	Rehiko 25 357 12-S

FLYWHEEL HOLDING TOOL

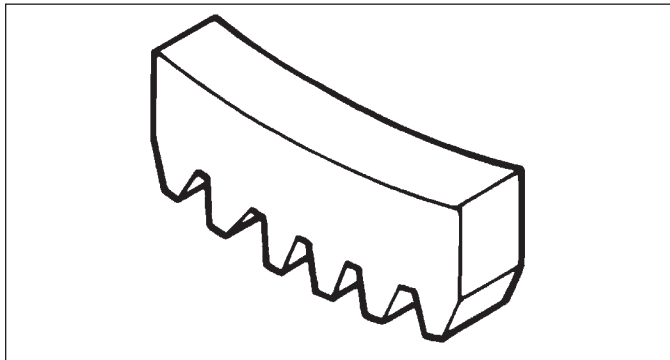

A flywheel holding tool can be made out of an old junk flywheel ring gear and used in place of a strap wrench.

1. Using an abrasive cut-off wheel, cut out a six tooth segment of ring gear as shown.
2. Grind off any burrs or sharp edges.
3. Invert segment and place it between ignition bosses on crankcase so tool teeth engage flywheel ring gear teeth. Bosses will lock tool and flywheel in position for loosening, tightening, or removing with a puller.

ROCKER ARM/CRANKSHAFT TOOL

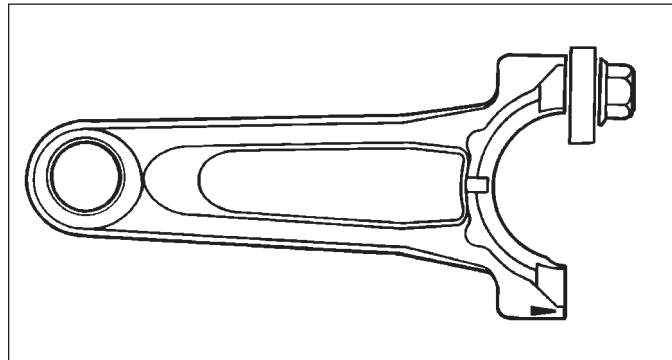

A spanner wrench to lift rocker arms or turn crankshaft may be made out of an old junk connecting rod.

1. Find a used connecting rod from a 10 HP or larger engine. Remove and discard rod cap.
2. Remove studs of a Posi-Lock rod or grind off aligning steps of a Command rod, so joint surface is flat.
3. Find a 1 in. long capscrew with correct thread size to match threads in connecting rod.
4. Use a flat washer with correct I.D. to slip on cap-screw and approximately 1 in. O.D. Assemble cap-screw and washer to joint surface of rod.

Troubleshooting

TROUBLESHOOTING GUIDE

When troubles occur, be sure to check simple causes which, at first, may seem too obvious to be considered. For example, a starting problem could be caused by an empty fuel tank.

Some general common causes of EFI engine troubles are listed below and vary by engine specification. Use these to locate causing factors.

Engine Cranks But Will Not Start

- Battery connected backwards.
- Blown fuses.
- Clogged fuel line or fuel filter.
- Empty fuel tank.
- Faulty ignition coil(s).
- Faulty spark plug(s).
- Fuel pump malfunction-vacuum hose clogged or leaking.
- Fuel shut-off valve closed.
- Insufficient voltage to electronic control unit.
- Interlock switch is engaged or faulty.
- Key switch or kill switch in OFF position.
- Low oil level.
- Quality of fuel (dirt, water, stale, mixture).
- Spark plug lead(s) disconnected.

Engine Starts But Does Not Keep Running

- Faulty cylinder head gasket.
- Faulty or misadjusted throttle controls.
- Fuel pump malfunction-vacuum hose clogged or leaking.
- Intake system leak.
- Loose wires or connections that intermittently ground ignition kill circuit.
- Quality of fuel (dirt, water, stale, mixture).
- Restricted fuel tank cap vent.

Engine Starts Hard

- Clogged fuel line or fuel filter.
- Engine overheated.
- Faulty ACR mechanism (Recoil Start).
- Faulty spark plug(s).
- Flywheel key sheared.
- Fuel pump malfunction-vacuum hose clogged or leaking.
- Interlock switch is engaged or faulty.
- Loose wires or connections that intermittently ground ignition kill circuit.
- Low compression.
- Quality of fuel (dirt, water, stale, mixture).
- Weak spark.

Engine Will Not Crank

- Battery is discharged.
- Faulty electric starter or solenoid.
- Faulty key switch or ignition switch.
- Interlock switch is engaged or faulty.
- Loose wires or connections that intermittently ground ignition kill circuit.
- Pawls not engaging in drive cup (Recoil Start).
- Seized internal engine components.

Engine Runs But Misses

- Fuel system issue (Fuel Injectors).
- Engine overheated.
- Faulty spark plug(s).
- Ignition module(s) faulty.
- Incorrect crankshaft position sensor air gap.
- Interlock switch is engaged or faulty.
- Loose wires or connections that intermittently ground ignition kill circuit.
- Quality of fuel (dirt, water, stale, mixture).
- Spark plug lead(s) disconnected.
- Spark plug lead boot loose on plug.
- Spark plug lead loose.

Engine Will Not Idle

- Engine overheated.
- Faulty spark plug(s).
- Idle speed adjusting screw improperly set.
- Inadequate fuel supply.
- Low compression.
- Quality of fuel (dirt, water, stale, mixture).
- Restricted fuel tank cap vent.

Engine Overheats

- Cooling fan broken.
- Excessive engine load.
- High crankcase oil level.
- Lean fuel mixture.
- Low crankcase oil level.
- Cooling system components clogged or restricted.

Engine Knocks

- Excessive engine load.
- Hydraulic lifter malfunction.
- Incorrect oil viscosity/type.
- Internal wear or damage.
- Low crankcase oil level.
- Quality of fuel (dirt, water, stale, mixture).
- Loose/worn pulley/clutch on crankshaft PTO.

Engine Loses Power

- Dirty air cleaner element.
- Engine overheated.
- Excessive engine load.
- Restricted exhaust.
- Faulty spark plug(s).
- High crankcase oil level.
- Incorrect governor setting.
- Low battery.
- Low compression.
- Low crankcase oil level.
- Quality of fuel (dirt, water, stale, mixture).

Engine Uses Excessive Amount of Oil

- Loose or improperly torqued fasteners.
- Blown head gasket/overheated.
- Breather reed broken.
- Clogged, broken, or inoperative crankcase breather.
- Crankcase overfilled.
- Incorrect oil viscosity/type.
- Worn cylinder bore.
- Worn or broken piston rings.
- Worn valve stems/valve guides.

Oil Leaks from Oil Seals, Gaskets

- Breather reed broken.
- Clogged, broken, or inoperative crankcase breather.
- Loose or improperly torqued fasteners.
- Piston blow by, or leaky valves.
- Restricted exhaust.



EXTERNAL ENGINE INSPECTION

NOTE: It is good practice to drain oil at a location away from workbench. Be sure to allow ample time for complete drainage.

Before cleaning or disassembling engine, make a thorough inspection of its external appearance and condition. This inspection can give clues to what might be found inside engines (and cause) when it is disassembled.

- Check for buildup of dirt and debris on crankcase, cooling fins, grass screen, and other external surfaces. Dirt or debris on these areas can cause overheating.
- Check for obvious fuel and oil leaks, and damaged components. Excessive oil leakage can indicate a clogged or inoperative breather, worn or damaged seals or gaskets, or loose fasteners.
- Check air cleaner cover and base for damage or indications of improper fit and seal.
- Check air cleaner element. Look for holes, tears, cracked or damaged sealing surfaces, or other damage that could allow unfiltered air into engine. A dirty or clogged element could indicate insufficient or improper maintenance.
- Check throttle body for dirt. Dirt in throat is further indication that air cleaner was not functioning properly.
- Check if oil level is within operating range on dipstick. If it is above, sniff for gasoline odor.
- Check condition of oil. Drain oil into a container; it should flow freely. Check for metal chips and other foreign particles. Sludge is a natural by-product of combustion; a small accumulation is normal. Excessive sludge formation could indicate over rich fuel settings, weak ignition, overextended oil change interval or wrong weight or type of oil was used.

CLEANING ENGINE

	 WARNING
	<p>Cleaning Solvents can cause severe injury or death.</p> <p>Use only in well ventilated areas away from ignition sources.</p>
<p>Carburetor cleaners and solvents are extremely flammable. Follow cleaner manufacturer's warnings and instructions on its proper and safe use. Never use gasoline as a cleaning agent.</p>	

After inspecting external condition of engine, clean engine thoroughly before disassembly. Clean individual components as engine is disassembled. Only clean parts can be accurately inspected and gauged for wear or damage. There are many commercially available cleaners that will quickly remove grease, oil, and grime from engine parts. When such a cleaner is used, follow manufacturer's instructions and safety precautions carefully.

Make sure all traces of cleaner are removed before engine is reassembled and placed into operation. Even small amounts of these cleaners can quickly break down lubricating properties of engine oil.

Troubleshooting

CRANKCASE VACUUM TEST

	⚠ WARNING
	Carbon Monoxide can cause severe nausea, fainting or death. Avoid inhaling exhaust fumes. Never run engine indoors or in enclosed spaces.
Engine exhaust gases contain poisonous carbon monoxide. Carbon monoxide is odorless, colorless, and can cause death if inhaled.	

	⚠ WARNING
	Rotating Parts can cause severe injury. Stay away while engine is in operation.
Keep hands, feet, hair, and clothing away from all moving parts to prevent injury. Never operate engine with covers, shrouds, or guards removed.	

A partial vacuum should be present in crankcase when engine is operating. Pressure in crankcase (normally caused by a clogged or improperly assembled breather) can cause oil to be forced out at oil seals, gaskets, or other available spots.

Crankcase vacuum is best measured with either a water manometer or a vacuum gauge. Complete instructions are provided in kits.

To test crankcase vacuum with manometer:

1. Insert rubber stopper into oil fill hole. Be sure pinch clamp is installed on hose and use tapered adapters to connect hose between stopper and one manometer tube. Leave other tube open to atmosphere. Check that water level in manometer is at 0 line. Make sure pinch clamp is closed.
2. Start engine and run no-load high speed.
3. Open clamp and note water level in tube. Level in engine side should be a minimum of 10.2 cm (4 in.) above level in open side. If level in engine side is less than specified (low/no vacuum), or level in engine side is lower than level in open side (pressure), check for conditions in table below.
4. Close pinch clamp before stopping engine. To test crankcase vacuum with vacuum/pressure gauge:

5. Remove dipstick or oil fill plug/cap.
6. Install adapter into oil fill/dipstick tube opening, upside down over end of a small diameter dipstick tube, or directly into engine if a tube is not used. Insert barbed gauge fitting into hole in stopper.
7. Run engine and observe gauge reading. Analog tester—needle movement to left of 0 is a vacuum, and movement to right indicates a pressure. Digital tester—depress test button on top of tester. Crankcase vacuum should be a minimum of 10.2 cm (4 in.) of water. If reading is below specification, or if pressure is present, check table below for possible causes and conclusions.

Condition	Conclusion
Crankcase breather clogged or inoperative.	NOTE: If breather is integral part of valve cover and cannot be serviced separately, replace valve cover and recheck pressure. Disassemble breather, clean parts thoroughly, check sealing surfaces for flatness, reassemble, and recheck pressure.
Seals and/or gaskets leaking. Loose or improperly torque fasteners.	Replace all worn or damaged seals and gaskets. Make sure all fasteners are tightened securely. Use appropriate torque values and sequences when necessary.
Piston blow by or leaky valves (confirm by inspecting components).	Recondition piston, rings, cylinder bore, valves and valves guides.
Restricted exhaust.	Check exhaust screen/spark arrestor (if equipped). Clean or replace as needed. Repair or replace any other damaged/restricted muffler or exhaust system parts.

COMPRESSION TEST

A compression test is best performed on a warm engine. Clean any dirt or debris away from base of spark plugs before removing them. Be sure battery is fully charged, unplug ECU, and throttle is wide open during test. Compression should be at least 160 psi and should not vary more than 15% between cylinders. **CYLINDER**

LEAKDOWN TEST

A cylinder leakdown test can be a valuable alternative to a compression test. By pressurizing combustion chamber from an external air source you can determine if valves or rings are leaking, and how badly.

Cylinder leakdown tester is a relatively simple, inexpensive leakdown tester for small engines. This tester includes a quick-connect for attaching adapter hose and a holding tool.

Dual Gauge Test Procedure

1. Run engine until oil temperature reaches and maintains 150°F (66°C) or more for a minimum of 5 minutes. Ideally, engine should be run under normal load conditions.
2. Remove spark plug(s) and air filter from engine.
3. Rotate crankshaft until piston (of cylinder being tested) is at top dead center (TDC) of compression stroke. Hold engine in this position while testing. Holding tool from kit can be used if PTO end of crankshaft is accessible. Lock holding tool onto crankshaft. Install a 3/8 in. breaker bar into hole/slot of holding tool, so it is perpendicular to both holding tool and crankshaft PTO. If flywheel end is more accessible, use a breaker bar and socket on flywheel nut/screw to hold it in position. An assistant may be needed to hold breaker bar during testing. If engine is mounted in a piece of equipment, it may be possible to hold it by clamping or wedging a driven component. Just be certain engine cannot rotate off TDC in either direction.
4. Connect an air source (at least 100 PSI) to tool.
5. Turn regulator knob clockwise (increase direction). Confirm both gauges read approximately the same air pressure from 0 to 80 PSI. Note any discrepancies between gauges for leakage calculation. Release pressure by turning regulator knob completely counterclockwise before proceeding.
6. Install adapter hose into spark plug hole of cylinder being tested. Use 12 mm x 14 mm adapter if required.
7. Firmly hold engine at TDC. Connect other end of adapter hose to tool quick connect. Turn regulator knob clockwise (increase direction) until left gauge needle reads 20 PSI.

NOTE: When piston is at TDC, little to no holding force should be required when air pressure is applied to cylinder. If excess holding force is required, this indicates piston is not at TDC. Readjust as necessary before proceeding.

8. Slowly turn regulator knob clockwise until left hand gauge maintains selected test pressure (see chart below).

Left Gauge Regulated Pressure Selection
80 PSI Recommended for engines over 200 cc or those exhibiting high leakage at 35 PSI setting.
35 PSI Recommended for single cylinder walk-behind push mower applications.

9. Compare right gauge reading to Test Pressure Chart on next page to identify percentage of leakage. Also refer to Leakdown Test Results chart on next page for colors, conditions, and action required.
10. For engines exhibiting leakage in yellow or red zone, repeat test procedure. Operate engine under normal load conditions prior to test. Confirm piston is at TDC during test.

NOTE: To prevent damage to gauge assembly, always turn pressure regulator knob to zero (counterclockwise) after each test.

Troubleshooting

Test Pressure Chart for Dual Gauge Tool

Left Gauge Regulated Pressure Selection	Right Gauge Reading in PSI											
80 PSI Recommended for engines over 200 cc or those exhibiting high leakage at 35 PSI setting.	80	72	64	56	48	40	32	24	16	8	0	
35 PSI Recommended for single cylinder walk-behind push mower applications.	35	31.5	28	24.5	21	17.5	14	10.5	7	3.5	0	
Percentage of leakage	0%	10%	20%	30%	40%	50%	60%	70%	80%	90%	100%	
	Green Zone				Yellow Zone				Red Zone			

Leakdown Test Results

Test Result	Condition	Action
Gauge reading in low (green) zone.	Piston rings and cylinder in good condition.	No further action required.
Gauge reading in moderate (yellow) zone.	Air escaping from crankcase breather and/or dipstick tube.	Some wear present causing leakage from combustion chamber to crankcase. Repair not required at this time if breather system is functioning normally.
	Air escaping from exhaust.	Exhaust valve leakage present, possibly due to carbon deposits. Repair not required. Carbon cleaning could be performed to reduce leakage.
Gauge reading in high (red) zone. Confirm consecutive leakdown test has been performed AFTER engine has been operated under normal load conditions.	Air escaping from intake.	Intake valve leakage present, possibly due to carbon deposits. Repair not required. Carbon cleaning could be performed to reduce leakage.
	Air escaping from crankcase breather and/or dipstick tube.	Excess wear present causing leakage from combustion chamber to crankcase. Breather system will not function normally and will fail crankcase vacuum test if this condition is truly present. Engine disassembly and analysis required to determine root cause and correction.
	Air escaping from exhaust.	Excess exhaust valve leakage present, possibly due to carbon deposits and/or valve to seat sealing issues. Carbon cleaning may reduce leakage. Valve grind and/or component replacement may be necessary. Excess oil consumption and/or excess heat is a suspect cause and must be resolved to prevent reoccurrence.
	Air escaping from intake.	Excess intake valve leakage present, possibly due to carbon deposits and/or valve to seat sealing issues. Carbon cleaning may reduce leakage. Valve grind and/or component replacement may be necessary. Excess oil consumption through intake valve and/or excess heat is a suspect cause and must be resolved to prevent reoccurrence. Inspect breather system components and intake valve stem sealing.

AIR CLEANER

These systems are CARB/EPA certified and components should not be altered or modified in any way.

Low-Profile Air Cleaner Components

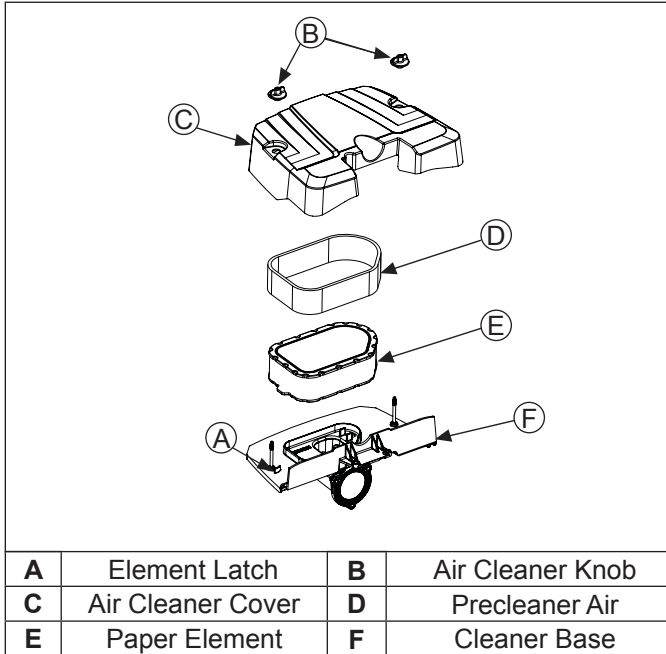

Heavy-Duty Air Cleaner Components

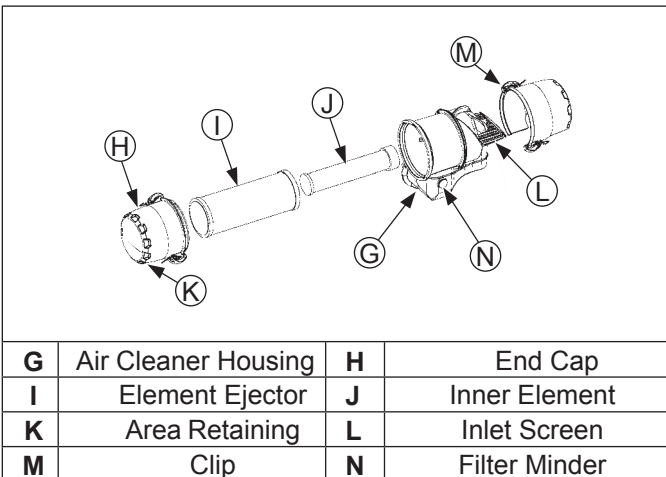

NOTE: Operating engine with loose or damaged air cleaner components could cause premature wear and failure. Replace all bent or damaged components.

NOTE: Paper element cannot be blown out with compressed air.

Low-Profile

Loosen knobs and remove air cleaner cover.

Precleaner

1. Remove precleaner from paper element.
2. Replace or wash precleaner in warm water with detergent. Rinse and allow to air dry.
3. Saturate precleaner with new engine oil; squeeze out excess oil.
4. Reinstall precleaner over paper element.

Paper Element 1.

1. Rotate element latch (if equipped); remove paper element with precleaner.
2. Separate precleaner from element; service precleaner and replace paper element.
3. Install new paper element on base; install precleaner over paper element; rotate element latch (if equipped).

Reinstall air cleaner cover and secure with knobs.

Heavy-Duty

1. Unhook retaining clips and remove end cap(s).
2. Check and clean inlet screen (if equipped).
3. Pull air cleaner element out of housing and replace. Check condition of inner element; replace when dirty.
4. Check all parts for wear, cracks, or damage, and that ejector area is clean.
5. Install new element(s).
6. Reinstall end cap(s) with dust ejector valve/screen down; secure with retaining clips.

BREATHER TUBE

Ensure both ends of breather tube are properly connected.

AIR COOLING

	WARNING
	Hot Parts can cause severe burns. Do not touch engine while operating or just after stopping.
Never operate engine with heat shields or guards removed.	

Proper cooling is essential. To prevent over heating, clean screens, cooling fins, and other external surfaces of engine. Avoid spraying water at wiring harness or any electrical components. Refer to Maintenance Schedule.

EFI SYSTEM

	<p>⚠ WARNING</p> <p>Explosive Fuel can cause fires and severe burns.</p> <p>Do not fill fuel tank while engine is hot or running.</p>
<p>Gasoline is extremely flammable and its vapors can explode if ignited. Store gasoline only in approved containers, in well ventilated, unoccupied buildings, away from sparks or flames. Spilled fuel could ignite if it comes in contact with hot parts or sparks from ignition. Never use gasoline as a cleaning agent.</p>	

Typical electronic fuel injection (EFI) system and related components include:

- Fuel pump module and lift pump.
- Fuel filter.
- High pressure fuel line.
- Fuel line(s).
- Fuel injectors.
- Throttle body/intake manifold.
- Electronic control unit (ECU).
- Ignition coils.
- Engine (oil) temperature sensor.
- Throttle position sensor (TPS).
- Crankshaft position sensor.
- Oxygen sensor.
- Temperature/Manifold Absolute Pressure (TMAP) sensor.
- Malfunction indicator light (MIL) - optional.
- 30 Amp fuse (charging system).
- 10 Amp fuse (ignition switch).
- 10 Amp fuse (battery power).
- Wire harness assembly & associated wiring.

FUEL RECOMMENDATIONS

Refer to Maintenance.

FUEL LINE

Low permeation fuel line must be installed on all Rehlko engines to maintain EPA and CARB regulatory compliance.

OPERATION

NOTE: When performing voltage or continuity tests, avoid putting excessive pressure on or against connector pins. Pin probes are recommended for testing to avoid spreading or bending terminals.

EFI system is designed to provide peak engine performance with optimum fuel efficiency and lowest possible emissions. Ignition and injection functions are electronically controlled, monitored and continually corrected during operation to maintain ideal air/fuel ratio.

Central component of system is Engine Control Unit (ECU) which manages system operation, determining best combination of fuel mixture and ignition timing for current operating conditions.

A lift fuel pump is used to move fuel from tank through an in-line fuel filter and fuel line. Fuel is then pumped to fuel pump module. Fuel pump module regulates fuel pressure to a system operating pressure of 39 psi. Fuel is delivered from fuel pump module through high pressure fuel line into injectors, which inject fuel into intake ports. ECU controls amount of fuel by varying length of time that injectors are on. This can range from 2 to over 12 milliseconds depending on fuel requirements. Controlled injection of fuel occurs every other crankshaft revolution, or once for each 4-stroke cycle. When intake valve opens, air/fuel mixture is drawn into combustion chamber, compressed, ignited, and burned.

ECU controls amount of fuel being injected and ignition timing by monitoring primary sensor signals for engine temperature, speed (RPM), and throttle position (load). These primary signals are compared to preprogrammed maps in ECU computer chip, and ECU adjusts fuel delivery to match mapped values. After engine reaches operating temperature, an exhaust gas oxygen sensor provides feedback to ECU based upon amount of unused oxygen in exhaust, indicating whether fuel mixture being delivered is rich or lean. Based upon this feedback, ECU further adjusts fuel input to re-establish ideal air/fuel ratio. This operating mode is referred to as closed loop operation. EFI system operates closed loop when all three of following conditions are met:

- Oil temperature is greater than 50-60°C (122-140°F).
- Oxygen sensor has warmed sufficiently to provide a signal (minimum 400°C, 752°F).
- Engine operation is at a steady state (not starting, warming up, accelerating, etc.).

During closed loop operation ECU has ability to readjust and learn adaptive controls, providing compensation for changes in overall engine condition and operating environment, so it will be able to maintain ideal air/ fuel ratio. This system requires a minimum engine oil temperature greater than 60-70°C (140-158°F) to properly adapt. These adaptive values are maintained as long as ECU is not reset.

During certain operating periods such as cold starts, warm up, acceleration, high load, etc., a richer air/fuel ratio is required and system operates in an open loop mode. In open loop operation oxygen sensor output is used to ensure engine is running rich, and controlling adjustments are based on primary sensor signals and programmed maps only. This system operates open loop whenever three conditions for closed loop operation (above) are not being met.

ECU is brain or central processing computer of entire EFI system. During operation, sensors continuously gather data which is relayed through wiring harness to input circuits within ECU. Signals to ECU include: ignition (on/off), crankshaft position and speed (RPM), throttle position, oil temperature, intake air temperature, exhaust oxygen levels, manifold absolute pressure, and battery voltage.

ECU compares input signals to programmed maps in its memory to determine appropriate fuel and spark requirements for immediate operating conditions. ECU then sends output signals to set injector duration and ignition timing.

ECU continually performs a diagnostic check of itself, each of sensors, and system performance. If a fault is detected, ECU can turn on a Malfunction Indicator Light (MIL) (if equipped) on equipment control panel, store fault code in its fault memory, and go into a default operating mode. Depending on significance or severity of fault, normal operation may continue. A technician can access stored fault code using a blink code diagnosis flashed out through MIL. An optional computer software diagnostic program is also available, see Tools and Aids. ECU requires a minimum of 6.0 volts to operate.

To prevent engine over-speed and possible failure, a rev-limiting feature is programmed into ECU. If maximum RPM limit (4500) is exceeded, ECU suppresses injection signals, cutting off fuel flow. This process repeats itself in rapid succession, limiting operation to preset maximum.

Wiring harness used in EFI system connects electrical components, providing current and ground paths for system to operate. All input and output signaling occurs through two special all weather connectors that attach and lock to ECU. Connectors are Black and Grey and keyed differently to prevent being attached to ECU incorrectly.

Condition of wiring, connectors, and terminal connections is essential to system function and performance. Corrosion, moisture, and poor connections are as likely cause of operating problems and system errors as an actual component. Refer to Electrical System for additional information.

EFI system is a 12 VDC negative ground system, designed to operate down to a minimum of 6.0 volts. If system voltage drops below this level, operation of voltage sensitive components such as ECU, fuel pump, ignition coils, and injectors will be intermittent or disrupted, causing erratic operation or hard starting. A fully charged, 12 volt battery with a minimum of 350 cold cranking amps is important in maintaining steady and reliable system operation. Battery condition and state of charge should always be checked first when troubleshooting an operational problem.

Keep in mind that EFI-related problems are often caused by wiring harness or connections. Even small amounts of corrosion or oxidation on terminals can interfere with milliamp currents used in system operation.

Cleaning connectors and grounds will solve problems in many cases. In an emergency situation, simply disconnecting and reconnecting connectors may clean up contacts enough to restore operation, at least temporarily.

If a fault code indicates a problem with an electrical component, disconnect ECU connector and test for continuity between component connector terminals and corresponding terminals in ECU connector using an ohmmeter. Little or no resistance should be measured, indicating that wiring of that particular circuit is OK.

Crankshaft position sensor is essential to engine operation; constantly monitoring rotation and speed (RPM) of crankshaft. There are 23 consecutive teeth cast into flywheel. One tooth is missing and is used to reference crankshaft position for ECU.

During rotation, an AC voltage pulse is created within sensor for each passing tooth. ECU calculates engine speed from time interval between consecutive pulses. Gap from missing tooth creates an interrupted input signal, corresponding to specific crankshaft position near BDC for cylinder #1. This signal serves as a reference for control of ignition timing by ECU. Synchronization of inductive speed pickup and crankshaft position takes place during first two revolutions each time engine is started. Sensor must be properly connected at all times. If sensor becomes disconnected for any reason, engine will quit running.

Throttle position sensor (TPS) is used to indicate throttle plate angle to ECU. Since throttle (by way of governor) reacts to engine load, angle of throttle plate is directly related to load on engine.

Mounted on throttle body and operated directly off end of throttle shaft, TPS works as a potentiometer, varying voltage signal to ECU in direct correlation to angle of throttle plate. This signal, along with other sensor signals, is processed by ECU and compared to internal preprogrammed maps to determine required fuel and ignition settings for amount of load.

Correct position of TPS is established and set at factory. Do not loosen TPS or alter mounting position unless absolutely required by fault code diagnosis. If TPS is loosened or repositioned, appropriate TPS Learn Procedure must be performed to re-establish baseline relationship between ECU and TPS.

Engine (oil) temperature sensor is used by system to help determine fuel requirements for starting (a cold engine needs more fuel than one at or near operating temperature).

Mounted in crankcase next to breather cover, it has a temperature-sensitive resistor that extends into oil flow. Resistance changes with oil temperature, altering voltage sent to ECU. Using a table stored in its memory, ECU correlates voltage drop to a specific temperature. Using fuel delivery maps, ECU then knows how much fuel is required for starting at that temperature.

Temperature/Manifold Absolute Pressure (TMAP) sensor is an integrated sensor that checks both intake air temperature and manifold absolute pressure.

Intake Air Temperature control is a thermally sensitive resistor that exhibits a change in electrical resistance with a change in its temperature. When sensor is cold, resistance of sensor is high. As sensor warms up, resistance drops and voltage signal increases. From voltage signal, ECU can determine temperature of intake air.

Purpose of sensing air temperature is to help ECU calculate air density. Higher air temperature less dense air becomes. As air becomes less dense ECU knows that it needs to lessen fuel flow to achieve correct air/fuel ratio. If fuel ratio was not changed engine would become rich, possibly losing power and consuming more fuel.

EFI SYSTEM

Manifold Absolute Pressure check provides immediate manifold pressure information to ECU. TMAP sensor measures difference in pressure between outside atmosphere and vacuum level inside intake manifold and monitors pressure in manifold as primary means of detecting load. Data is used to calculate air density and determine engine's mass air flow rate, which in turn determines required ideal fueling. TMAP also stores instant barometric pressure reading when key is turned ON.

Oxygen sensor functions like a small battery, generating a voltage signal to ECU based upon difference in oxygen content between exhaust gas and ambient air.

Tip of sensor, protruding into exhaust gas, is hollow. Outer portion of tip is surrounded by exhaust gas, with inner portion exposed to ambient air. When oxygen concentration on one side of tip is different than that of other side, a voltage signal up to 1.0 volt is generated and sent to ECU. Voltage signal tells ECU if engine is straying from ideal fuel mixture, and ECU then adjusts injector pulse accordingly.

Oxygen sensor functions after being heated to a minimum of 400°C (752°F). A heater inside sensor heats electrode to optimum temperature in about 10 seconds. Oxygen sensor receives ground through wire, eliminating need for proper grounding through muffler. If problems indicate a bad oxygen sensor, check all connections and wire harness. Oxygen sensor can also be contaminated by leaded fuel, certain RTV and/or other silicone compounds, fuel injector cleaners, etc. Use only those products indicated as O2 Sensor Safe.

Fuel injectors mount into intake manifold, and high pressure fuel line attaches to them at top end. Replaceable O-rings on both ends of injector prevent external fuel leakage and also insulate it from heat and vibration. A special clip connects each injector to high pressure fuel line and holds it in place. O-rings and retaining clip must be replaced any time fuel injector is separated from its normal mounting position.

When key switch is on, fuel pump module will pressurize high pressure fuel line to 39 psi, and voltage is present at injector. At proper instant, ECU completes ground circuit, energizing injector. Valve needle in injector is opened electromagnetically, and pressure in high pressure fuel line forces fuel down through inside. Director plate at tip of injector contains a series of calibrated openings which directs fuel into manifold in a cone-shaped spray pattern.

Injectors have sequential fueling that open and close once every other crankshaft revolution. Amount of fuel injected is controlled by ECU and determined by length of time valve needle is held open, also referred to as injection duration or pulse width. Time injector is open (milliseconds) may vary in duration depending on speed and load requirements of engine.

A high-voltage, solid-state, battery ignition system is used with EFI system. ECU controls ignition output and timing through transistorized control of primary current delivered to coils. Based on input from crankshaft position sensor, ECU determines correct firing point for speed at which engine is running. At proper instant, it interrupts flow of primary current in coil, causing electromagnetic flux field to collapse. Flux collapse induces an instantaneous high voltage in coil secondary which is strong enough to bridge gap on spark plug. Each coil fires every other revolution.

EFI engines are equipped with either a 20 or 25 amp charging system to accommodate combined electrical demands of ignition system and specific application. Charging system troubleshooting information is provided in Electrical System.

An electric fuel pump module and a lift pump are used to transfer fuel in EFI system. Pumping action is created by direct lever/pump actuation off rocker arm movement. Pumping action causes diaphragm on inside of pump to pull fuel in on its downward stroke and to push it into fuel pump module on its upward stroke. Internal check valves prevent fuel from going backward through pump. Fuel pump module receives fuel from lift pump, increases and regulates pressure for fuel injectors.

Fuel pump module is rated for a minimum output of 13.5 liters per hour and regulated at 270 kilopascals (39 psi).

When key switch is turned ON and all safety switch requirements are met, ECU activates fuel pump module for about six seconds, which pressurizes system for start-up. If key switch is not promptly turned to start position, engine fails to start, or engine is stopped with key switch ON (as in case of an accident), ECU switches off pump preventing continued delivery of fuel. In this situation, MIL will go on, but it will go back off after 4 cranking revolutions if system function is OK. Once engine is running, fuel pump remains on.

Precision components inside fuel pump module are not serviceable. DO NOT attempt to open fuel pump module. Damage to components will result and warranty will be void. Because fuel pump module is not serviceable, engines are equipped with a special 10-micron EFI fuel filter to prevent harmful contamination from entering module.

If there are two filters in system, one before lift pump will be a standard 51-75 micron filter, and one after lift pump will be special 10-micron filter. Be sure to use an approved 10-micron filter for replacement.

High pressure fuel line is an assembly of hoses, injector caps and a fuel connector to fuel pump module. High pressure fuel line feeds fuel to top of injectors through injector caps. Caps are fastened to intake manifold and injectors are locked into place. A small retaining clip provides a secondary lock.

High pressure fuel line is serviced as a complete assembly to prevent tampering and safety hazards. Components are not individually serviceable.

Vent hose assembly is intended to vent fuel vapor out of fuel pump module and direct fuel vapor into throttle body. Most EFI engines are equipped with an engine mounted purge port on #2 cylinder barrel baffle. This capped purge port can be used by OEM to vent fuel tanks or used in conjunction with a carbon canister kit for Tier III evaporative emissions compliance. Purge port connects to vent hose assembly and directs all fuel vapor into throttle body. If purge port remains unused, port must remain capped to prevent dirt from entering engine.

EFI engines have no carburetor, so throttle function (regulate incoming combustion airflow) is achieved with a throttle valve in a separate throttle body attached to intake manifold. Throttle body/intake manifold provides mounting for fuel injectors, TMAP sensor, high pressure fuel line, idle speed screw, and air cleaner assembly.

Idle and high speed adjustments may be performed on EFI system. Standard idle speed setting for EFI engines is 1500 RPM, but certain applications might require a different setting. Check Rehlko Plus and equipment manufacturer's recommended settings.

For starting and warm up, ECU will adjust fuel and ignition timing, based upon ambient temperature, engine temperature, and loads present. In cold conditions, idle speed will probably be different than normal for a few moments. Under other conditions, idle speed may actually start lower than normal, but gradually increase to established setting as operation continues. Do not attempt to circumvent this warm up period, or readjust idle speed during this time. Engine must be completely warmed up, in closed loop operating mode for accurate idle adjustment.

IMPORTANT NOTES!

- Cleanliness is essential and must be maintained at all times when servicing or working on EFI system. Dirt, even in small quantities, can cause significant problems.
- Clean any joint or fitting with parts cleaning solvent before opening to prevent dirt from entering system.
- Always depressurize fuel system through fuel connector on fuel pump module before disconnecting or servicing any fuel system components.
- Never attempt to service any fuel system component while engine is running or ignition switch is ON.
- Do not use compressed air if system is open. Cover any parts removed and wrap any open joints with plastic if they will remain open for any length of time. New parts should be removed from their protective packaging just prior to installation.
- Avoid direct water or spray contact with system components.
- Do not disconnect or reconnect ECU wiring harness connector or any individual components with ignition on. This can send a damaging voltage spike through ECU.
- Do not allow battery cables to touch opposing terminals. When connecting battery cables attach positive (+) cable to positive (+) battery terminal first, followed by negative (-) cable to negative (-) battery terminal.
- Never start engine when cables are loose or poorly connected to battery terminals.
- Never disconnect battery while engine is running.
- Never use a quick battery charger to start engine.
- Do not charge battery with key switch ON.
- Always disconnect negative (-) battery cable before charging battery, and also unplug harness from ECU before performing any welding on equipment.

EFI SYSTEM

ELECTRICAL COMPONENTS

Electronic Control Unit (ECU)

Pinout of ECU

Black Connector Side	
Pin #	Function
1	Ignition Coil #1 Ground
2	Battery Ground
3	Diagnostic Communication Line
4	Crankshaft Position Sensor input
5	Fuel Injector Output #1 Ground
6	Fuel Injector Output #2 Ground
7	Oxygen Sensor Heater
8	Intake Air Temperature (TMAP) sensor input
9	Fuel Pump Ground
10	Ground for TPS, TMAP, O2 and Oil Sensors
11	Manifold Absolute Pressure (TMAP) sensor input
12	Throttle Position Sensor (TPS) input
13	Crankshaft Position Sensor Ground
14	Oil Temperature Sensor input
15	Ignition Switch (Switched +12V)
16	Power for TPS and TMAP Sensors (+5V)
17	Oxygen Sensor (O2) input
18	Battery Power (Permanent +12V)

Grey Connector Side	
Pin #	Description
1	Not Used
2	Not Used
3	Malfunction Indicator Light (MIL) Ground
4	Not Used
5	Not Used
6	GCU Tach Output (Electronic Governor)
7	Not Used
8	Not Used
9	Battery Ground
10	Ignition Coil #2 Ground
11	Not Used
12	Not Used
13	Not Used
14	Safety Switch Ground
15	Not Used
16	ECU
17	Fuel Pump Control (+12V)
18	Not Used

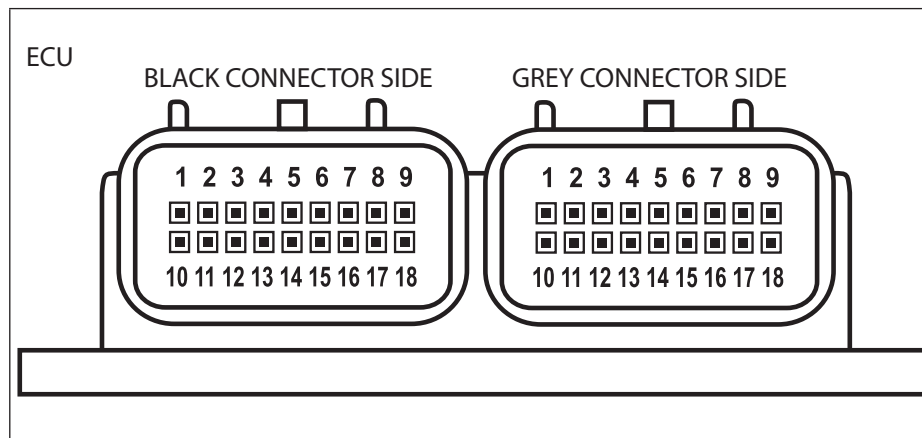

Pinout of ECU

Never attempt to disassemble ECU. It is sealed to prevent damage to internal components. Warranty is void if case is opened or tampered with in any way.

All operating and control functions within ECU are preset. No internal servicing or readjustment may be performed. If a problem is encountered, and you determine ECU to be faulty, contact your source of supply.

ECU pins are coated at factory with a thin layer of electrical grease to prevent fretting and corrosion. Do not attempt to remove grease from ECU pins.

Relationship between ECU and throttle position sensor (TPS) is very critical to proper system operation. If TPS or ECU is changed, or mounting position of TPS is altered, appropriate TPS Learn Procedure must be performed to restore synchronization.

Any service to ECU, TPS/Throttle Body (including idle speed increase over 300 RPM), or fuel pump module replacement should include ECU Reset.

This will clear all trouble codes, all closed loop learned offsets, all max values, and all timers besides permanent hour meter.

This system will NOT reset when battery is disconnected!

ECU Reset Procedure

1. Turn key/ignition OFF.
2. Install Red wire jumper from Rehlko EFI service kit on to service port (connect white wire to black wire in 4 way diagnostic port).
3. Turn key/ignition ON, then OFF and count 10 seconds.
4. Turn key/ignition ON, then OFF and count to 10 seconds a second time.
5. Remove Red wire jumper. Turn key/ignition ON, then OFF and count to 10 seconds a third time. ECU is reset.

A TPS Learn Procedure **must** be performed after ECU reset.

TPS Learn Procedure

1. Turn idle screw clockwise one full turn prior to key/ignition ON after ECU Reset.
2. Start engine, run at low idle until engine is warm.
3. Idle speed must be above 1500 RPM. If below 1500 RPM, turn idle screw up to 1700 RPM and then shut down engine and perform ECU Reset again.
4. Adjust idle speed down to 1500 RPM. Allow engine to dwell at 1500 RPM for about 3 seconds.
5. After this, adjust idle speed to final specified speed setting.
6. Turn key/ignition OFF and count to 10 seconds.

Learn procedure is complete.

EFI SYSTEM

Wiring Harness
EFI Wiring Diagram 8-Terminal Connector

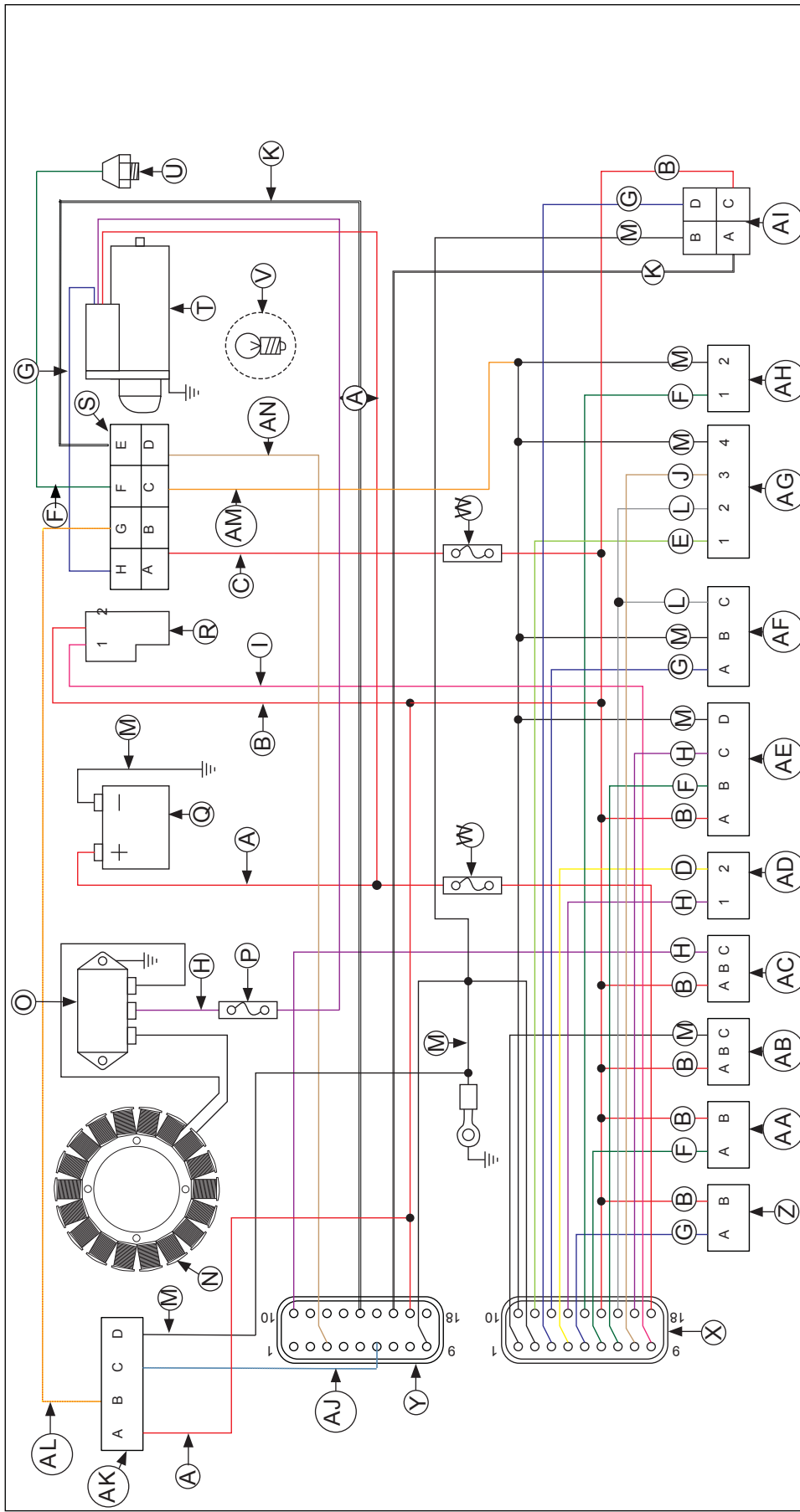

A	Red	B	Red/Black	C	Red/White	D	Yellow	E	Light Green
F	Dark Green	G	Dark Blue	H	Purple	I	Pink	J	Tan
K	White	L	Grey	M	Black	N	Stator	O	Rectifier-Regulator
P	30A Fuse	Q	Battery	R	Fuel Pump	S	8-Terminal Connector	T	Starter Motor
U	Oil Pressure Switch	V	MIL (Optional)	W	10A Fuse	X	Black Connector	Y	Grey Connector
Z	Fuel Injector #1	AA	Fuel Injector #2	AB	Ignition Coil #1	AC	Ignition Coil #2	AD	Crankshaft Position Sensor
AE	Oxygen Sensor	AF	Throttle Position Sensor	AG	TMAP Sensor	AH	Oil Temperature Sensor	AI	Diagnostic Connector
AJ	Grey/Blue	AK	Electronic Governor only	AL	Red/Yellow	AM	Orange	AN	Tan (MIL Ground)

Crankshaft Position Sensor

A sealed, non-serviceable assembly. If Fault Code diagnosis indicates a problem within this area, test and correct as follows.

1. Inspect wiring and connections for damage or problems.
2. Make sure engine has resistor type spark plugs.
3. Disconnect Black connector from ECU.
4. Connect an ohmmeter between #4 and #13 pin terminals. A resistance value of 325-395 Ω at room temperature (20°C, 68°F) should be obtained.
5. If resistance is incorrect, remove blower housing.
6. Disconnect crankshaft position sensor connector from wiring harness. Test resistance between terminals. A reading of 325-395 Ω should again be obtained.
 - a. If resistance is incorrect, remove screws securing sensor to mounting bracket and replace sensor.
 - b. If resistance in step 4 was incorrect, but resistance of sensor alone was correct, test wire harness circuits between sensor connector terminals and corresponding pin terminals (#4 and #13) in main connector. Correct any observed problem, reconnect sensor, and perform step 5 again.
7. If resistance is correct from step 4, check mounting, flywheel teeth (damage, run-out, etc.) and flywheel key.
8. When fault is corrected and engine starts, clear fault codes following ECU Reset procedure.

Throttle Position Sensor (TPS)

TPS is a sealed, non-serviceable assembly. If diagnosis indicates a bad sensor, complete replacement is necessary. A magnet that sensor detects is separate, and can be replaced or reused. If a blink code indicates a problem with TPS, it can be tested as follows:

Diagnostics of sensor: ECU will have electrical faults captured in fault codes P0122 and P0123. Fault code P0122 detecting low voltage, open circuit, and P0123 for high voltage conditions between ECU, wire harness, and sensor. Tip: when working with any electrical connection, remember to keep connections clean & dry. This is best accomplished by cleaning connection thoroughly prior to disassembly. Contaminated sensor connections can cause premature engine faults. Functionally testing sensor can no longer be done with simple resistance checks. If either of these two faults is present or a TPS fault is suspected, recommended diagnostic test is as follows:

If a computer with diagnostic software is available

Observe throttle percent and raw TPS values through diagnostic software. With diagnostic software communicating to ECU and key ON engine not running, these values can be observed while throttle is moved from closed to full open position. There should be a smooth and repeatable throttle percent value starting at closed position reading between 0% to WOT position of 100%.

If one of these values is outside of specified range and output transitions in a smooth manner, reset ECU and run test again. Since there is no longer any wear elements inside sensor, most likely faults will be in electrical connections between sensor and wire harness and wire harness to ECU. With service software communicating to ECU and engine not running, a small load or gentle back and forth motion can be applied to connectors or wires just outside connectors to detect a faulty connection.

If only a volt meter is available

Measure voltage supply to sensor from ECU. This voltage should be 5.00 +/- 0.20 volts. This can be measured by gently probing terminals B & C on harness side with TPS connector removed from TPS and key ON. This will generate a P0122 fault that can be cleared with an ECU reset. If voltage is low, battery, harness and ECU should be investigated. If supply voltage is good, plug sensor back into harness. Probe sensor signal wire with volt meter, terminal A at TPS or pin Black 12 at ECU. This signal should start between 0.6-1.2 volts at low idle and grow smoothly as throttle is opened to 4.34.8 volts at full open (WOT). Since there is no longer any wear elements inside sensor, most likely faults will be in electrical connections between sensor and wire harness and wire harness to ECU.

Replace magnet assembly

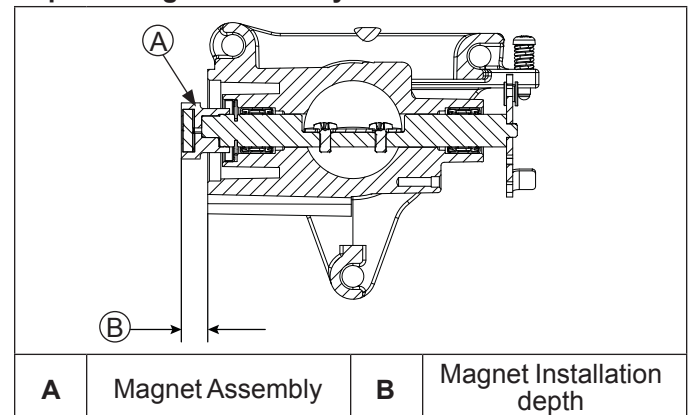

Magnet assembly is captured in a small plastic housing that is press fit to end of throttle shaft. This generally does not need replacement. If replacement is required, can be replaced as follows:

1. Remove sensor from throttle body, exposing round magnet assembly.
2. A pair of flat blade screw drivers or a spanner tool can be used to pry this off shaft. Caution should be used to avoid damage to machined flat surface that sensor seals against. Also, make sure throttle blade is in full open position to avoid driving throttle blade into throttle bore causing damage to blade and/or bore.
3. When replacing magnet assembly, alignment is critical. There is a D-shaped drive feature on end of shaft and a matching pocket in magnet assembly. On outer diameter of magnet assembly is a notch that aligns with center of flat feature of D. Align this notch and flat of D feature in shaft and preassemble parts.

EFI SYSTEM

4. With throttle blade in full open position (WOT), press magnet assembly fully on to throttle shaft. Full insertion can be checked by measuring height from throttle body sensor mounting face to end of magnet assembly. This should be no more than 8.6 mm (0.338 in.). Installation process requires significant force, so take care that all parts are aligned. Tapping magnet assembly on can fracture/damage brittle magnet within assembly and throttle body assembly and is NOT RECOMMENDED.

Engine (Oil) Temperature Sensor

A sealed, non-serviceable assembly. A faulty sensor must be replaced. If a blink code indicates a problem with temperature sensor, it can be tested as follows:

1. Remove temperature sensor from breather cover and cap or block sensor hole.
2. Wipe sensor clean and allow it to reach room temperature (25°C, 77°F).
3. Unplug Black connector from ECU.
4. With sensor still connected, check temperature sensor circuit resistance between Black pin 10 and 14 terminals. Value should be 9000-11000 Ω.
5. Unplug sensor from wire harness and check sensor resistance separately across two pins. Resistance value should again be 9000-11000 Ω.
 - a. If resistance is out of specifications, replace temperature sensor.
 - b. If it is within specifications, proceed to Step 6.
6. Check circuits (input, ground), from wire harness connector to sensor plug for continuity, damage, etc. Connect one ohmmeter lead to Black pin 14 in wire harness connector (as in step 4). Connect other lead to terminal #1 in sensor plug. Continuity should be indicated. Repeat test between Black pin 10 and terminal #2 in sensor plug.

Temperature/Manifold Absolute Pressure (TMAP) Sensor

A sealed non-serviceable integrated sensor that checks both intake air temperature and manifold absolute pressure. Complete replacement is required if it is faulty. Sensor and wiring harness can be checked as follows.

If a blink code indicates a problem with Intake Air Temperature (TMAP) Sensor Circuit (P0112 or P0113), it can be tested as follows:

1. Remove TMAP sensor from intake manifold.
2. Allow it to reach room temperature (20°C, 68°F).
3. Unplug Black connector from ECU.
4. With sensor still connected, check temperature sensor circuit resistance between Black pin 10 and 8 pin terminals. Value should be 1850-2450 Ω.
5. Unplug sensor from wire harness and check sensor resistance separately across pin. Resistance value should again be 1850-2450 Ω.

- a. If resistance is out of specifications, check local temperature. Sensor resistance will go down as temperature is higher. Replace TMAP sensor if determined to be faulty.
 - b. If it is within specifications, proceed to Step 6.
6. Check circuits (input, ground), from main harness connector to sensor plug for continuity, damage, etc. Connect one ohmmeter lead to Black pin 8 in main harness connector (as in step 4). Connect other lead to terminal #3 in sensor plug. Continuity should be indicated. Repeat test between Black pin 10 and terminal #4 in sensor plug.

7. Reinstall sensor.

If a blink code indicates a problem with Manifold Absolute Pressure (TMAP) Sensor Circuit (P0107 or P0108), it can be tested as follows:

1. Make sure all connections are making proper contact and are free of dirt and debris. Slide locking tab out and pull off TMAP connector. Turn key switch to ON and check with a volt meter by contacting red lead to pin 1 and black lead to pin 2. There should be 5 volts present, indicating ECU and wiring harness are functioning.
2. Check continuity in wire harness. Ohms between Pin 3 at sensor connector and Black pin 11 connector at ECU should be near zero ohms. If no continuity is measured or very high resistance, replace wire harness.
3. Check to make sure intake manifold is not loose and TMAP sensor is not loose. Loose parts would allow a vacuum leak, making TMAP sensor report misleading information to ECU.
 - a. Tighten all hardware and perform an ECU Reset and a TPS Learn Procedure to see if MIL will display a fault with sensor again. If MIL finds a fault with TMAP sensor, replace it.

Oxygen Sensor (O₂)

Components

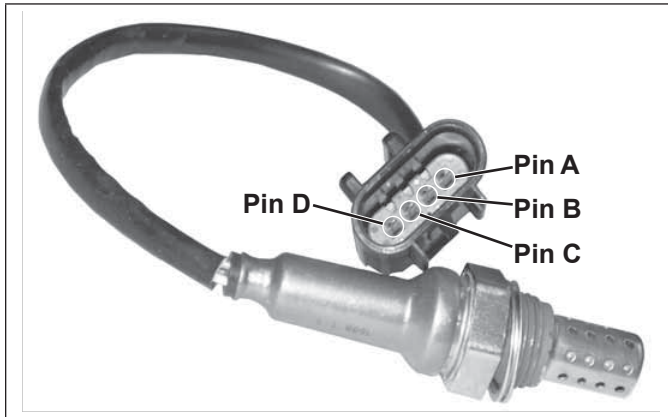

Cutaway Oxygen Sensor Components (O₂)

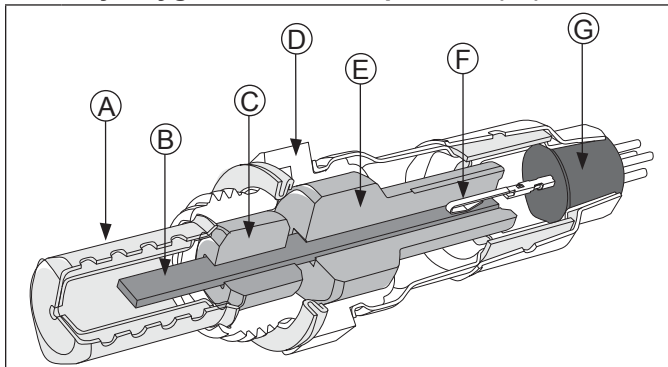

A	Protection Shield	B	Planar Element and Heater
C	Lower Insulator	D	Stainless Steel Housing
E	Upper Insulator	F	Terminal Connection to Element
G	Water Seal High Temp		

Temperature must be controlled very accurately and gas constituents measured to a high degree of accuracy for absolute sensor measurements. This requires laboratory equipment to determine a good or bad sensor in field. Furthermore, as with most devices, intermittent problems are difficult to diagnose. Still, with a good understanding of system and sensor, it is possible to diagnose many sensor problems in field.

Using diagnostic software connected to ECU is a useful technique for observing sensor performance. However, user must understand that such software reads a signal generated by ECU. If there is an ECU or wiring problem, readings could be misinterpreted as a sensor problem. Digital nature of signal to software means that it is not reading continuous output of sensor. A voltmeter can also be used as an effective tool in diagnosing sensors. It is advisable to use an electronic meter such as a digital voltmeter. Simple mechanical meters may place a heavy electrical load on sensor and cause inaccurate readings. Since resistance of sensor is highest at low temperatures, such meters will cause largest inaccuracies when sensor is in a cool exhaust.

Visual Inspection

1. Look for a damaged or disconnected sensor-to-engine harness connection.
2. Look for damage to sensor lead wire or associated engine wiring due to cutting, charring or melting on a hot surface.
3. Disconnect sensor connector and look for corrosion in connector.
4. Try reconnecting sensor and observe if problem has cleared.
5. Correct any problems found during visual check.

Sensor Signal Observation

NOTE: Do not cut into or pierce sensor or engine wiring to make this connection. Sensor produces a very small signal. Corrosion or damage to wiring could lead to an incorrect signal because of repairs or contamination to sensor.

1. Using a voltmeter, observe voltage between Pin C and Pin D before engine is started. With key ON, and sensor unplugged, voltage should read about 5.0 volts. With sensor attached, using diagnostic software, voltage should read about 1.0 volt. This voltage is generated by ECU. If it is not present, there is a short in associated wiring and corrective action should be taken. If voltage still is not present, there is a problem with ECU or engine harness.
2. Reconnect sensor and start engine. Run engine at sufficient speed to bring sensor up to operating temperature. Maintain for 1 to 2 minutes to ensure that engine has gone closed loop. Once in closed loop, sensor voltage should cycle between about 100 to 250 mv (low speed idle) and 700 to 900 mv (high speed no load). If this cycling is not observed, a determination must be made, if problem is with engine or sensor.
3. Check engine harness for battery voltage on heater circuit.

Removal Inspection

NOTE: Apply anti-seize compound only to threads.

Anti-seize compound will affect sensor performance if it gets into lower shield of sensor.

1. If sensor has heavy deposits on lower shield, engine, oil, or fuel may be source.
2. If heavy carbon deposits are observed, incorrect engine fuel control may be occurring.
3. If sensor is at room temperature, measure between signal leads, black wire (Pin C) and grey wire (Pin D) attached to sensor. If resistance is less than one megohm, sensor has an internal short.
4. With sensor at room temperature measure heater circuit resistance, purple wire (Pin A) and white wire (Pin B), resistance should be 8.1-11.1 Ω .
5. If a damaged sensor is found, identify root cause, which may be elsewhere in application. Refer to Troubleshooting-Oxygen Sensor (O₂) table.



EFI SYSTEM

6. A special "dry to touch" anti-seize compound is applied to all new oxygen sensors at factory. If recommended mounting thread sizes are used, this material provides excellent anti-seize capabilities and no additional anti-seize is needed. If sensor is removed from engine and reinstalled, anti-seize compound should be reapplied. Use an oxygen sensor safe type anti-seize compound. It should be applied according to directions on label.

Troubleshooting-Oxygen Sensor (O₂)

Condition	Possible Cause	Conclusion
Low voltage output.	Shorted sensor or sensor circuit. Shorted lead wire. Wiring shorted to ground.	Replace sensor or repair wiring.
	Contamination of air reference.	Remove source of external contamination, protect air reference area.
	Air leak at sensor or gasket, sensor upper shield damage.	Use recommended torque at installation, replace gasket or sensor. Revise application exhaust. Shield sensor from damage.
High voltage output.	Silica poisoning.	Replace sensor.
	Contaminated gasoline.	Use high quality fuel.
	Engine problem; misfire.	Correct cause of misfire.
	Excessive rich air/fuel ratio.	Check for high fuel pressure Leaking injector Liquid fuel in vent line
	Wiring shorted to voltage.	Repair wiring.
Open circuit, no activity from sensor.	Broken element . Sensor dropped. Hard blow to engine or exhaust system. Defective sensor. Thermal shock.	Replace sensor.
Slow time response.	Open heater circuit. Improper handling. Carbon deposits.	Replace sensor.
	Improper fueling.	Correct fueling.
	Incorrect or contaminated fuel.	Use high quality fuel.
	Excessive engine oil consumption causing exhaust contamination or other exhaust side contamination.	Correct engine condition.
	Heater circuit open/shorted or out of specification.	Repair short in harness wires, replace sensor.

Fuel Injectors

	 WARNING
	Explosive Fuel can cause fires and severe burns. Fuel system ALWAYS remains under HIGH PRESSURE.
Wrap a shop towel completely around fuel pump module connector. Press release button(s) and slowly pull connector away from fuel pump module allowing shop towel to absorb any residual fuel in high pressure fuel line. Any spilled fuel must be completely wiped up immediately.	

Details

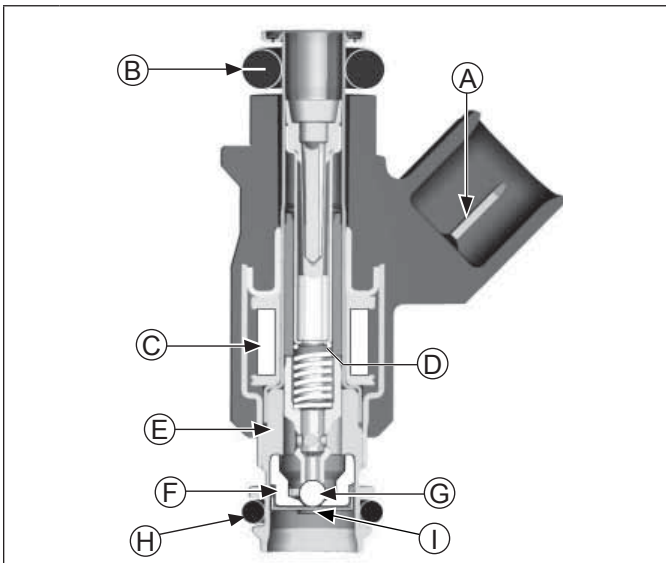

A	Electrical Connection	B	Upper O-ring
C	Solenoid Winding	D	Armature
E	Valve Housing	F	Valve Seat
G	Valve End	H	Lower O-ring
I	Director Plate		

NOTE: Do not apply voltage to fuel injector(s). Excessive voltage will burn out injector(s). Do not ground injector(s) with ignition ON. Injector(s) will open/turn on if relay is energized.

NOTE: When cranking engine with injectors disconnected, fault codes will be registered in ECU and will need to be cleared using software fault clear or an ECU Reset and TPS Learn Procedure.

Injector problems typically fall into three general categories: electrical, dirty/clogged, or leakage. An electrical problem usually causes one or both of injectors to stop functioning. Several methods may be used to check if injectors are operating.

1. With engine running at idle, listen for a buzzing or clicking sound.
2. Disconnect electrical connector from an injector and listen for a change in idle performance (only running on one cylinder) or a change in injector noise or vibration.

If an injector is not operating, it can indicate either a bad injector, or a wiring/electrical connection problem. Check as follows:

1. Disconnect electrical connector from both injectors. Plug a 12 volt noid light into one connector.
2. Make sure all safety switch requirements are met. Crank engine and check for flashing of noid light. Turn key OFF for at least 10 seconds between tests to allow ECU to go to sleep and reawake. Repeat test at other connector.
 - a. If flashing occurs, use an ohmmeter (Rx1 scale) and check resistance of each injector across two terminals. Proper resistance is 11-13 Ω . If injector resistance is correct, check whether connector and injector terminals are making a good connection. If resistance is not correct, replace injector.

Check all electrical connections, connectors, and wiring harness leads if resistance is incorrect.

Injector leakage is very unlikely, but in those rare instances it can be internal (past tip of valve needle), or external (weeping around injector O-rings). Loss of system pressure from leakage can cause hot restart problems and longer cranking times. Refer to Disassembly for removal of injector.

1. Remove manifold mounting bolts and separate throttle body/manifold from engine leaving TPS, high pressure fuel line, injectors and fuel line connections intact. Discard old gaskets.
2. Position manifold assembly over an appropriate container to capture fuel and turn key switch ON to activate fuel pump and pressurize system. Do not turn switch to START position.

NOTE: Fuel pump module pins are coated with a thin layer of electrical grease to prevent fretting and corrosion. Do not attempt to remove electrical grease from fuel pump module pins.

3. If either injector exhibits leakage of more than two to four drops per minute from tip, or shows any sign of leakage around outer shell, turn ignition switch OFF and replace injector as follows.
4. Depressurize fuel system.
5. Clean any dirt accumulation from sealing/mounting area of faulty injector(s) and disconnect electrical connector(s).
6. Pull retaining clip off top of injector(s). Remove screw holding injector(s) from manifold.

EFI SYSTEM

- Reverse appropriate procedures to install new injector(s) and reassemble engine. Use new O-rings and retaining clips any time an injector is removed (new replacement injectors include new O-rings and retaining clips). Lubricate O-rings lightly with clean engine oil. Use installation tool provided with O-rings to install new upper O-ring. Place tool into fuel injector inlet. Place one side of O-ring into O-ring groove and roll O-ring over tool onto fuel injector. Torque screw securing fuel injector caps and blower housing mounting screws to 7.3 N·m (65 in. lb.), and intake manifold and air cleaner mounting screws to 11.3 N·m (100 in. lb.). An ECU Reset will need to be completed.

Injector problems due to dirt or clogging are generally unlikely due to design of injectors, high fuel pressure, and detergent additives in gasoline. Symptoms that could be caused by dirty/clogged injectors include rough idle, hesitation/stumbling during acceleration, or triggering of fault codes related to fuel delivery. Injector clogging is usually caused by a buildup of deposits on director plate, restricting flow of fuel, resulting in a poor spray pattern. Some contributing factors to injector clogging include higher than normal operating temperatures, short operating intervals, and dirty, incorrect, or poor quality fuel. Cleaning of clogged injectors is not recommended; they should be replaced. Additives and higher grades of fuel can be used as a preventative measure if clogging has been a problem.

Ignition Coil

If a coil is determined to be faulty, replacement is necessary. An ohmmeter may be used to test wiring and coil windings.

NOTE: Do not ground primary coil with ignition ON as they may overheat or spark.

NOTE: Always disconnect spark plug lead from spark plug before performing following tests.

NOTE: **If ignition coil(s) are disabled and an ignition fault is registered, system will automatically disable corresponding fuel injector drive signal.** Fault must be corrected to ignition coil and ECU power (switch) must be turned OFF for 10 seconds for injector signal to return. This is a safety measure to prevent bore washing and oil dilution.

Testing

Using an ohmmeter set on Rx1 scale, check resistance in circuits as follows:

- To check cylinder coil 1 (starter side), disconnect Black connector from ECU and test between Black pins 1 and 15. To check cylinder coil 2 (oil filter side), disconnect Grey connector from ECU and test between Grey pins 10 and 17. Wiring and coil primary circuits are OK if readings are 0.5-0.8 Ω .
- If reading(s) are not within specified range, check and clean connections and retest.
- If reading(s) are still not within specified range, test coils separately from main harness as follows:
 - Remove screw retaining coil to housing and disconnect primary leads connector.

- Connect an ohmmeter set on Rx1 scale to primary terminals of coil. Primary resistance should be 0.5-0.8 Ω .
- Connect an ohmmeter set on Rx10K scale between spark plug boot terminal and B+ primary terminal. Secondary resistance should be no more than 1100 Ω .
- If secondary resistance is not within specified range, coil is faulty and needs to be replaced.

FUEL COMPONENTS

	WARNING
	Explosive Fuel can cause fires and severe burns. Fuel system ALWAYS remains under HIGH PRESSURE.
Wrap a shop towel completely around fuel pump module connector. Press release button(s) and slowly pull connector away from fuel pump module allowing shop towel to absorb any residual fuel in high pressure fuel line. Any spilled fuel must be completely wiped up immediately.	

Fuel Pump Module (FPM)

Fuel pump module is not serviceable and must be replaced if determined to be faulty. If a fuel pump problem is suspected, make certain pump is being activated, all electrical connections are properly secured, fuses are good, and a minimum of 7.0 volts is being supplied. If during cranking, voltage drops below 7.0 volts, a reduction of fuel pressure may occur resulting in a lean starting condition. If required, testing of fuel pump may be conducted.

- Relieve fuel pressure at fuel pump module. Fuel pump module may need to be loosened or pulled away from engine. Disconnect fuel coupler from fuel pump module and insert pressure test jumper (from Rehiko EFI Service Kit) between high pressure fuel line and fuel pump module.
- Connect black hose of Pressure Tester. Route clear hose into a portable gasoline container or equipment fuel tank.
- Turn on key switch to activate pump and check system pressure on gauge. It may take several key cycles to compress air introduced into system and reach regulated pressure. If system pressure of 39 psi \pm 3 is observed, wiring, fuel pump, and regulator are working properly. Turn key switch OFF and depress valve button on tester to relieve system pressure.
 - If pressure is too high or too low, replace fuel pump module.
- If pump did not activate (step 3), disconnect plug from fuel pump. Connect a DC voltmeter across terminals in plug, turn on key switch and observe if a minimum of 7 volts is present during six second prime process.
- If no voltage is observed, connect red lead of meter to red wire of plug and black lead to a good ground while key is still ON.

6. If voltage is between 7 and 14, turn key switch OFF and connect an ohmmeter between terminals on pump to check for continuity.
 - a. If there was no continuity between pump terminals, replace fuel pump.
 - b. If voltage was below 7, test wiring harness.
7. If voltage at plug was good, and there was continuity across pump terminals, reconnect plug to pump, making sure you have a good connection. Turn on key switch and listen for pump to activate.
 - a. If pump starts, repeat steps 2 and 3 to verify correct pressure.
 - b. If pump still does not operate, replace it.

High Pressure Fuel Line

High pressure fuel line is mounted to intake manifold. No specific servicing is required unless operating conditions indicate that it needs replacement. Thoroughly clean area around all joints and relieve any pressure before starting any disassembly. Detach by removing two mounting screws, wire ties, and injector retaining clips.

Purge Port and Vent Hose Assembly

No specific servicing is required for vent hose assembly or purge port unless operating conditions indicate replacement is required. All components are serviced individually. Abrasion sleeves on hoses should be reused or replaced when servicing vent hoses. Please note vent hose routing and replicate after service or component replacement to prevent pinching or abrasion of vent hoses. Only Rehlko replacement parts can be used because fitting is specific to system and must be maintained. Visit Engines.rehlko.com for recommended Rehlko replacement parts.

Throttle Body/Intake Manifold Assembly

NOTE: ECU Reset is required if throttle body is replaced.

Throttle body is serviced as an assembly, with throttle shaft, TPS, throttle plate, and idle speed adjusting screw installed. Throttle shaft rotates on needle bearings (non-serviceable), capped with seals to prevent air leaks.

TROUBLESHOOTING

Troubleshooting Guide

Condition	Possible Cause
Engine Starts Hard or Fails to Start When Cold.	Fuel pump not running.
	Faulty spark plugs.
	Old/stale fuel.
	Incorrect fuel pressure.
	Crankshaft position sensor loose or faulty.
	TPS set incorrect (ECU Reset and TPS Learn).
	TPS faulty.
	Engine temp sensor faulty.
	Faulty coils.
	Low system voltage.
	Faulty injectors.
	Faulty battery.
	Loose or corroded connections.

EFI SYSTEM

Troubleshooting Guide

Condition	Possible Cause
Engine Starts Hard or Fails to Start When Hot.	Faulty spark plugs.
	Fuel pump not running.
	Fuel pressure low.
	Insufficient fuel delivery.
	TPS set incorrect (ECU Reset and TPS Initialization).
	Crankshaft position sensor loose or faulty.
	TPS faulty.
	Engine temp sensor faulty.
	Faulty injectors.
Engine Stalls or Idles Roughly (cold or warm).	Faulty spark plugs.
	Insufficient fuel delivery.
	TPS set incorrect.
	TPS faulty.
	Faulty engine temperature sensor.
	Faulty injectors.
Engine Misses, Hesitates, or Stalls Under Load.	Fuel injector(s), fuel filter, fuel line, or fuel pick-up dirty/restricted.
	Dirty air cleaner.
	Insufficient fuel pressure or fuel delivery.
	Vacuum (intake air) leak.
	Improper governor setting, adjustment or operation.
	TPS faulty, mounting problem or TPS Initialization Procedure incorrect.
	Bad coil(s), spark plug(s), or wires.
Low Power	Faulty/malfunctioning ignition system.
	Dirty air filter.
	Insufficient fuel delivery.
	Improper governor adjustment.
	Plugged/restricted exhaust.
	One injector not working.
	Basic engine problem exists.
	TPS faulty or mounting exists.
Throttle plate in throttle body not fully opening to WOT stop (if equipped).	

Function Test

	WARNING
	<p>High Pressure Fluids can puncture skin and cause severe injury or death.</p> <p>Do not work on fuel system without proper training or safety equipment.</p>
<p>Fluid puncture injuries are highly toxic and hazardous. If an injury occurs, seek immediate medical attention.</p>	

Function of fuel system is to provide sufficient delivery of fuel at system operating pressure of 39 psi ± 3. If an engine starts hard, or turns over but will not start, it may indicate a problem with EFI fuel system. A quick test will verify if system is operating.

1. Disconnect and ground spark plug leads.
2. Complete all safety interlock requirements and crank engine for approximately 3 seconds.
3. Remove spark plugs and check for fuel at tips.
 - a. If there is fuel at tips of spark plugs fuel pump and injectors are operating.
 - b. If there is no fuel at tips of spark plugs, check following:
 1. Make sure fuel tank contains clean, fresh, proper fuel.
 2. Make sure that vent in fuel tank is open.
 3. Make sure fuel tank valve (if equipped) is fully opened.
 4. Make sure battery is supplying proper voltage.
 5. Check that fuses are good, and that no electrical or fuel line connections are damaged or broken.
 6. Test fuel pump module operation as described earlier under Fuel Pump.

Fault Codes

Example of Diagnostic Display

<p>★ ★ ★ ★ ★ ★ ★ ★ ★ ★ (0)</p> <p>One second pause</p> <p>★ (1)</p> <p>One second pause</p> <p>★ ★ ★ ★ ★ ★ ★ ★ ★ ★ (0)</p> <p>One second pause</p> <p>★ ★ ★ ★ ★ ★ ★ ★ (7)</p>	<p>} Fault Code 0107</p> <p>} End Code 61</p>
---	---

Diagnostic Fault Code Summary

Fault Code	Connection or Failure Description
0031	Oxygen Sensor Heater Circuit Low Voltage
0032	Oxygen Sensor Heater Circuit High Voltage
0107	Manifold Absolute Pressure (MAP or TMAP) Sensor Circuit Low Voltage or Open
0108	Manifold Absolute Pressure (MAP or TMAP) Sensor Circuit High Voltage
0112	Intake Air Temperature (IAT or TMAP) Sensor Circuit Low Voltage
0113	Intake Air Temperature (IAT or TMAP) Sensor Circuit High Voltage or Open
0117	Coolant/Oil Temperature Sensor Circuit Low Voltage
0118	Coolant/Oil Temperature Sensor Circuit High Voltage or Open
0122	Throttle Position Sensor Circuit Low Voltage or Open
0123	Throttle Position Sensor Circuit High Voltage
0131	Oxygen Sensor 1 Circuit Low Voltage, or Open
0132	Oxygen Sensor 1 Circuit High Voltage
0171	Maximum Adaptation Limit Exceeded
0172	Minimum Adaptation Limit Exceeded
0174	Lean Fuel Condition at High Load (Open Loop)
0201	Injector 1 Circuit Malfunction
0202	Injector 2 Circuit Malfunction

EFI SYSTEM

Fault Code	Connection or Failure Description
0230	Fuel Pump Module Circuit Low Voltage or Open
0232	Fuel Pump Module Circuit High Voltage
0336	Crankshaft Position Sensor Noisy Signal
0337	Crankshaft Position Sensor No Signal
0351	Cylinder 1 Ignition Coil Malfunction
0352	Cylinder 2 Ignition Coil Malfunction
0562	System Voltage Low
0563	System Voltage High
0650	MIL Circuit Malfunction
1693	Tach Output (ECU) Low
1694	Tach Output (ECU) High
61	End of Code Transmission

ECU continuously monitors engine operation against preset performance limits. If operation is outside limits, ECU activates MIL, if equipped, and stores a diagnostic code in its fault memory. If component or system returns to proper function, ECU will turn off MIL. If MIL stays illuminated, it warns customer a fault is currently happening, and dealer service is required. Upon receipt, dealer technician can access fault code(s) to help determine what portion of system is malfunctioning.

Codes are accessed through key switch and displayed as blinks or flashes of MIL. Access codes as follows:

1. Check that battery voltage is above 11 volts.
2. Start with key switch OFF.
3. Turn key switch to ON and OFF, then ON and OFF, then ON, leaving it on in third sequence. Do not start engine. Time between sequences must be less than 2.5 seconds.
4. MIL will blink a series of times. Number of times MIL blinks represents a number in blink code.
5. A sequence of four digits make up a fault code. There is a one (1) second pause between blinks of a fault code. There is a three (3) second pause between separate fault codes. After fault code(s) are blinked a two digit 61 is blinked to indicate program has completed.
 - a. It's a good idea to write down codes as they appear, as they may not be in numerical sequence.
 - b. Code 61 will always be last code displayed, indicating end of code transmission. If code 61 appears immediately, no other fault codes are present.

After problem has been corrected, fault codes may be cleared by following ECU Reset and TPS Learn Procedures.

Diagnostic Fault Code Summary lists fault codes, and what they correspond to. Diagnostic Code Summary is a list of individual codes with an explanation of what triggers them, what symptoms might be expected, and probable causes.

A MIL may not be provided with engine. If equipment manufacturer has not added a MIL to equipment, one can be added easily for quick diagnostics. Main engine to vehicle connection will have a tan wire which is ground for MIL. Either incandescent or LED type bulbs can be used for MIL as long as they do not draw more than 0.1 amps. Bulb needs to be rated at 1.4 Watts or less, or needs to have a total resistance of 140 Ω or more. LEDs typically draw less than 0.03 amps. Attach +12 volts to positive terminal of bulb and attach ground terminal of bulb to tan wire.

Diagnostic Code Summary Code 0031

Component:	Oxygen Sensor Heater
Fault:	O2S Heater Circuit Low Voltage
Condition:	System voltage too low, open connection or faulty sensor.
Conclusion:	Engine Wiring Harness Related <ul style="list-style-type: none"> ● Pin circuit wiring or connectors. ECU black pin 7 or broken wire. Oxygen Sensor Related <ul style="list-style-type: none"> ● Sensor connector or wiring problem. Poor system ground from ECU to engine or battery to engine.

Code 0032

Component:	Oxygen Sensor Heater
Fault:	O2S Heater Circuit High Voltage
Condition:	System voltage too high, shorted connection or faulty sensor.
Conclusion:	Oxygen Sensor Related <ul style="list-style-type: none"> ● Sensor connector or wiring problem. ● Sensor damaged. ● Pin circuit wiring or connectors at Black ECU Related ECU-to-harness connection problem.

Code 0107

Component:	Manifold Absolute Pressure (TMAP)
Fault:	TMAP Circuit Low Voltage or Open
Condition:	Intake manifold leak, open connection or faulty sensor.
Conclusion:	<p>TMAP Sensor Related</p> <ul style="list-style-type: none"> ● Sensor malfunction. ● Vacuum leaks from loose manifold or sensor. <p>Wire Harness Related</p> <ul style="list-style-type: none"> ● Poor grounding or open circuit. ● Wire harness and connectors loose, damaged or corroded. ● Pin circuit wiring or connectors at Black 10, 11 and 16. <p>Bad TPS Learn.</p>

Code 0108

Component:	Manifold Absolute Pressure (TMAP)
Fault:	TMAP Circuit High Voltage
Condition:	Intake manifold leak, shorted connection or faulty sensor.
Conclusion:	<p>TMAP Sensor Related</p> <ul style="list-style-type: none"> ● Sensor malfunction. ● Vacuum leaks from loose manifold or sensor. <p>Wire Harness Related</p> <ul style="list-style-type: none"> ● Poor grounding. ● Pin circuit wiring or connectors at Black <p>Bad TPS Learn.</p>

Code 0112

Component:	Intake Air Temperature (TMAP)
Fault:	Intake Air Temperature Sensor Circuit Low Voltage
Condition:	Shorted connection, faulty sensor or shorted wire.
Conclusion:	<p>TMAP Sensor Related</p> <ul style="list-style-type: none"> ● Sensor wiring or connection. <p>Engine Wiring Harness Related</p> <ul style="list-style-type: none"> ● Pin circuits Black 10 and Black 8 may be damaged or routed near noisy signal (coils, alternator, etc.). ● ECU-to-harness connection problem.

Code 0113

Component:	Intake Air Temperature (TMAP)
Fault:	Intake Air Temperature Sensor Circuit High Voltage or Open
Condition:	Shorted connection, faulty sensor, broken wire or connection.
Conclusion:	<p>TMAP Sensor Related</p> <ul style="list-style-type: none"> ● Sensor wiring or connection. <p>Engine Wiring Harness Related</p> <ul style="list-style-type: none"> ● Pin circuits ECU Black pin 10 and 8 may be damaged. ● ECU-to-harness connection problem or broken wire.

Code 0117

Component:	Coolant/Oil Sensor
Fault:	Coolant/Oil Temperature Sensor Circuit Low Voltage
Condition:	Shorted connection, faulty sensor or shorted wire.
Conclusion:	<p>Temperature Sensor Related</p> <ul style="list-style-type: none"> ● Sensor wiring or connection. <p>Engine Wiring Harness Related</p> <ul style="list-style-type: none"> ● Pin circuits Black 10 and Black 14 maybe damaged or routed near noisy signal (coils, stator, etc.). ● ECU-to-harness connection problem.

Code 0118

Component:	Coolant/Oil Sensor
Fault:	Coolant/Oil Temperature Sensor Circuit High Voltage or Open
Condition:	Shorted connection, faulty sensor, open connection or broken wire.
Conclusion:	<p>Temperature Sensor Related</p> <ul style="list-style-type: none"> ● Sensor wiring or connection. <p>Engine Wiring Harness Related</p> <ul style="list-style-type: none"> ● Pin circuits ECU Black pin 10 and 14 may be damaged. ● ECU-to-harness connection problem or broken wire. <p>System Related</p> <ul style="list-style-type: none"> ● Engine is operating above 176°C (350°F) temperature sensor limit.

EFI SYSTEM

Code 0122

Component:	Throttle Position Sensor (TPS)
Fault:	TPS Circuit Low Voltage or Open
Condition:	Open connection, broken wire or faulty sensor.
Conclusion:	<p>TPS Related</p> <ul style="list-style-type: none"> ● TPS bad or worn internally. <p>Engine Wiring Harness Related</p> <ul style="list-style-type: none"> ● Broken or shorted wire in harness. ECU Black pin 10 to TPS pin 1. ECU Black pin 12 to TPS pin 3. ECU Black pin 16 to TPS pin 2. <p>Throttle Body Related</p> <ul style="list-style-type: none"> ● Throttle shaft inside TPS worn, broken, or damaged. ● Throttle plate loose or misaligned. ● Throttle plate bent or damaged allowing extra airflow past, or restricting movement. <p>ECU Related</p> <ul style="list-style-type: none"> ● Circuit providing voltage or ground to TPS damaged. ● TPS signal input circuit damaged.

Code 0123

Component:	Throttle Position Sensor (TPS)
Fault:	TPS Circuit High Voltage
Condition:	Shorted connection or faulty sensor.
Conclusion:	<p>TPS Sensor Related</p> <ul style="list-style-type: none"> ● Sensor connector or wiring. ● Sensor output affected or disrupted by dirt, grease, oil, wear. ● Sensor loose on throttle body manifold. <p>Throttle Body Related</p> <ul style="list-style-type: none"> ● Throttle shaft or bearings worn/ damaged. <p>Engine Wiring Harness Related</p> <ul style="list-style-type: none"> ● ECU pins Black 10, 12 and 16 damaged (wiring, connectors). ● ECU pins Black 10, 12 and 16 routed near noisy electrical signal (coils, alternator). ● Intermittent 5 volt source from ECU (pin Black 16). ● ECU-to-harness connection problem.

Code 0131

Component:	Oxygen Sensor
Fault:	O2S 1 Circuit Low Voltage
Condition:	Open connection, broken wire or faulty sensor.
Conclusion:	<p>Oxygen Sensor Related</p> <ul style="list-style-type: none"> ● Sensor connector or wiring problem. ● Sensor contaminated, corroded or damaged. ● Poor ground path. ● Pin circuit wiring or connectors. ECU Black pin 10 or 17. <p>TPS Learn Procedure Incorrect</p> <ul style="list-style-type: none"> ● Lean condition (check oxygen sensor signal with VOA and see Oxygen Sensor section). <p>Engine wiring harness related such as a cut wire, broken or pinched.</p>

Code 0132

Component:	Oxygen Sensor
Fault:	O2S 1 Circuit High Voltage
Condition:	Shorted connection or faulty sensor.
Conclusion:	<p>Oxygen Sensor Related</p> <ul style="list-style-type: none"> ● Sensor connector or wiring problem. ● Sensor contaminated or damaged. ● Poor ground path. ● Pin circuit wiring or connectors. ECU Black pin 10 or Black pin 17. <p>Engine Wiring Harness Related</p> <ul style="list-style-type: none"> ● Difference in voltage between sensed voltage and actual sensor voltage. ● Short in wire harness.

Code 0171

Component:	Fuel System
Fault:	Maximum adaptation limit exceeded
Condition:	Fuel inlet screen/filter plugged, low pressure at high pressure fuel line, TPS malfunction, shorted connection, faulty sensor, low fuel or wrong fuel type.
Conclusion:	<p>Oxygen Sensor Related</p> <ul style="list-style-type: none"> ● Corrosion or poor connection. ● Sensor contaminated or damaged. ● Air leak into exhaust. ● Poor ground path. ● Pin circuit wiring or connectors. ECU Black pin 10 or Black pin 17. <p>TPS Sensor Related</p> <ul style="list-style-type: none"> ● Throttle plate position incorrect during Learn procedure. ● TPS problem or malfunction. <p>Engine Wiring Harness Related</p> <ul style="list-style-type: none"> ● Difference in voltage between sensed voltage and actual sensor voltage. ● Problem in wiring harness. ● ECU-to-harness connection problem. <p>Systems Related</p> <ul style="list-style-type: none"> ● Ignition (spark plug, plug wire, ignition coil). ● Fuel (fuel type/quality, injector, fuel pressure too low, fuel pump module or lift pump). ● Combustion air (air cleaner dirty/restricted, intake leak, throttle bores). ● Base engine problem (rings, valves). ● Exhaust system leak (muffler, flange, oxygen sensor mounting boss, etc.). ● Fuel in crankcase oil.

Code 0172

Component:	System
Fault:	Minimum adaptation limit exceeded
Condition:	Too high pressure at high pressure fuel line, TPS malfunction, shorted connection, faulty sensor or fuel pump module failure.
Conclusion:	<p>Oxygen Sensor Related</p> <ul style="list-style-type: none"> ● Sensor connector or wiring. ● Sensor contaminated or damaged. ● Poor ground path. ● Pin circuit wiring or connectors. ECU Black pin 10 or 17. <p>TPS Sensor Related</p> <ul style="list-style-type: none"> ● Throttle plate position incorrect during Learn procedure. ● TPS problem or malfunction. <p>Engine Wiring Harness Related</p> <ul style="list-style-type: none"> ● Difference in voltage between sensed voltage and actual sensor voltage. ● Problem in wiring harness. ● ECU-to-harness connection problem. <p>Systems Related</p> <ul style="list-style-type: none"> ● Ignition (spark plug, plug wire, ignition coil). ● Fuel (fuel type/quality, injector, fuel pressure too high, fuel pump module or lift pump). ● Combustion air (air cleaner dirty/restricted). ● Base engine problem (rings, valves). ● Fuel in crankcase oil. ● Fuel pump module is over filled. ● Lift pump diaphragm is ruptured.

EFI SYSTEM

Code 0174

Component:	Fuel System
Fault:	Lean fuel condition
Condition:	Fuel inlet screen/filter plugged, low pressure at high pressure fuel line, TPS malfunction, shorted connection or faulty sensor.
Conclusion:	<p>TPS Learn Incorrect</p> <ul style="list-style-type: none"> Lean condition (check oxygen sensor signal with VOA and see Oxygen Sensor). <p>Engine Wiring Harness Related</p> <ul style="list-style-type: none"> Pin circuit wiring or connectors. ECU pin Black 10, 12, 16 and 17. <p>Low Fuel Pressure</p> <ul style="list-style-type: none"> Plugged filters. Bad lift pump. <p>Oxygen Sensor Related</p> <ul style="list-style-type: none"> Sensor connector or wiring problem. Exhaust leak. Poor ground. <p>Poor system ground from ECU to engine, causing rich running while indicating lean.</p> <p>Fuel pump module connection. See Fuel Components.</p>

Code 0201

Component:	Fuel Injector
Fault:	Injector 1 Circuit Malfunction
Condition:	Injector damaged or faulty, shorted or open connection.
Conclusion:	<p>Injector Related</p> <ul style="list-style-type: none"> Injector coil shorted or opened. <p>Engine Wiring Harness Related</p> <ul style="list-style-type: none"> Broken or shorted wire in harness. ECU pin Black 5. Wiring from Ignition. <p>ECU Related</p> <ul style="list-style-type: none"> Circuit controlling injector #1 damaged.

Code 0202

Component:	Fuel Injector
Fault:	Injector 2 Circuit Malfunction
Condition:	Injector damaged or faulty, shorted or open connection.
Conclusion:	<p>Injector Related</p> <ul style="list-style-type: none"> Injector coil shorted or opened. <p>Engine Wiring Harness Related</p> <ul style="list-style-type: none"> Broken or shorted wire in harness. ECU pin Black 6. Wiring from Ignition. <p>ECU Related</p> <ul style="list-style-type: none"> Circuit controlling injector #2 damaged.

Code 0230

Component:	Fuel Pump
Fault:	Circuit Low Voltage or Open
Condition:	Shorted or open connection.
Conclusion:	<p>Fuel Pump Related</p> <ul style="list-style-type: none"> Fuel pump module open or shorted internally. <p>Engine Wiring Harness related</p> <ul style="list-style-type: none"> Broken or shorted wire in harness. ECU pin Black 9 or Grey 17. <p>ECU Related</p> <ul style="list-style-type: none"> ECU is damaged.

Code 0232

Component:	Fuel Pump
Fault:	Circuit High Voltage
Condition:	Shorted connection.
Conclusion:	<p>Fuel Pump Related</p> <ul style="list-style-type: none"> Fuel pump module damaged internally. <p>Charging Output System Too High.</p>

Code 0336

Component:	Crankshaft Position Sensor
Fault:	Crankshaft Position Sensor Noisy Signal
Condition:	Loose sensor, faulty/bad battery, shorted or faulty connection, faulty sensor or faulty sensor grounding.
Conclusion:	<p>Crankshaft Position Sensor Related</p> <ul style="list-style-type: none"> • Sensor connector or wiring. • Sensor loose. <p>Crankshaft Position Sensor Wheel Related</p> <ul style="list-style-type: none"> • Damaged teeth. • Gap section not registering. <p>Engine Wiring Harness Related</p> <ul style="list-style-type: none"> • Pin circuit wiring or connectors. ECU pin Black 4 and Black 13. • ECU-to-harness connection problem. <p>Ignition System Related</p> <ul style="list-style-type: none"> • Non-resistor spark plug(s) used. • Faulty or disconnected ignition coil or secondary lead.

Code 0337

Component:	Crankshaft Position Sensor
Fault:	Crankshaft Position Sensor No Signal
Condition:	Loose sensor, open or shorted connection or faulty sensor.
Conclusion:	<p>Crankshaft Position Sensor Related</p> <ul style="list-style-type: none"> • Sensor connector or wiring. • Sensor loose. <p>Crankshaft Position Sensor Wheel Related</p> <ul style="list-style-type: none"> • Damaged teeth. <p>Engine Wiring Harness Related</p> <ul style="list-style-type: none"> • Pin circuit wiring or connectors. ECU pin Black 4 or Black 13. • ECU-to-harness connection problem. <p>If code is stored in fault history and starts normally. Clear code, no other service required.</p>

Code 0351

Component:	Ignition Coil
Fault:	Cylinder 1 Ignition Coil Malfunction
Condition:	Broken wire in harness (may not be visible), shorted connection or faulty sensor.
Conclusion:	<p>Engine Wiring Harness Related</p> <ul style="list-style-type: none"> • Connection to ignition or fuse. • Pin circuit wiring or connectors. • ECU pin Black 1. • ECU-to-harness connection problem. <p>Ignition System Related</p> <ul style="list-style-type: none"> • Incorrect spark plug(s) used. • Poor connection to spark plug.

Code 0352

Component:	Ignition Coil
Fault:	Cylinder 2 Ignition Coil Malfunction
Condition:	Broken wire in harness (may not be visible), shorted connection or faulty sensor.
Conclusion:	<p>Engine Wiring Harness Related</p> <ul style="list-style-type: none"> • Connection to ignition or fuse. • Pin circuit wiring or connectors. ECU pin Grey 10. • ECU-to-harness connection problem. <p>Ignition System Related</p> <ul style="list-style-type: none"> • Incorrect spark plug(s) used. • Poor connection to spark plug.

Code 0562

Component:	System Voltage
Fault:	System Voltage Low
Condition:	Faulty voltage regulator, bad fuse or shorted connection.
Conclusion:	<p>Corroded Connections</p> <p>Bad Stator</p> <p>Bad Battery</p> <ul style="list-style-type: none"> • Low output charging system. • Poor magnet in flywheel. • Bad or missing fuse.

Code 0563

Component:	System Voltage
Fault:	System Voltage High
Condition:	Faulty voltage regulator or shorted connection.
Conclusion:	<p>Faulty Rectifier-Regulator</p> <p>Bad Stator.</p> <p>Bad Battery.</p>

Code 0650

Component:	MIL Circuit
Fault:	MIL Circuit Malfunction
Condition:	Failure in MIL circuit detected.
Conclusion:	<p>Bad ECU.</p> <p>Bad Connection.</p> <p>Broken Wire.</p>

Code 1693

Component:	Tach Output (ECU)
Fault:	Tach Circuit Low
Condition:	Tachometer output circuit short to ground.
Conclusion:	<p>Bad Tach Wire (grounded).</p> <p>GCU circuit short to ground.</p>

EFI SYSTEM

Code 1694

Component:	Tach Output (ECU)
Fault:	Tach Circuit High
Condition:	Tachometer output circuit short to battery.
Conclusion:	ECU or GCU circuit error.

Code 61

Component:	End of Code Transmission
------------	--------------------------

Troubleshooting Flow Chart

Flow chart provides an alternative method of troubleshooting EFI system. Chart will enable you to review entire system in about 10-15 minutes. Using chart, accompanying diagnostic aids (listed chart), and any signaled fault codes, you should be able to quickly locate any problems within system.

Flow Chart Diagnostic Aids

Diagnostic Aid #1 SYSTEM POWER

(MIL does not illuminate when key is turned ON)

NOTE: MIL is installed by vehicle OEM. Twelve volt supply to bulb will be part of vehicle wire harness. Rehlko key switch model will have MIL on engine with 12V supply to bulb.

Conclusion

- Battery
- Main system fuse
- MIL light bulb burned out
- MIL electrical circuit problem
Pin circuits Grey 3.
- Ignition switch
- Permanent ECU power circuit problem
Pin circuit Black 18.
- Switched ECU power circuit problem
Pin circuit Black 15.
- ECU grounds
- ECU

Diagnostic Aid #2 FAULT CODES

Refer to Diagnostic Fault Code Summary.

Diagnostic Aid #3 RUN/ON

(MIL remains ON while engine is running)*

Condition

NOTE: Either incandescent or LED type bulbs can be used for MIL as long as they do not draw more than 0.1 amps. Bulb needs to be rated at 1.4 Watts or less, or needs to have a total resistance of 140 Ω or more. LEDs typically draw less than 0.03 amps.

*All current fault codes will turn on MIL when engine is running.

Diagnostic Aid #4 CRANKSHAFT POSITION SENSOR (MIL does not turn off during cranking)

Condition

- Crankshaft position sensor
- Crankshaft position sensor circuit problem, pin circuits Black 4 and Black 13.
- Crankshaft position sensor/toothed wheel air gap
- Toothed wheel
- Flywheel key sheared
- ECU

Diagnostic Aid #5 FUEL PUMP (fuel pump not turning on)

Condition

- Main fuse
- Fuel pump circuit problem, pin circuits Black 9 and Grey 17.
- Fuel pump module

Diagnostic Aid #6 IGNITION SYSTEM (no spark)

Condition

- Spark plug
- Plug wire
- Coil
- Coil circuit(s), pin circuits Grey 10 and Black 1.
- ECU grounds
- ECU
- Vehicle safety interlocks, ground signal on safety wire.

Diagnostic Aid #7 FUEL SYSTEM ELECTRICAL (no fuel delivery)

Condition

- No fuel
- Air in high pressure fuel line
- Fuel valve shut OFF
- Fuel filter/line plugged
- Injector circuit(s), pin circuits Black 5 and Black 6
- Injector
- ECU grounds
- ECU
- Lift pump not working

Diagnostic Aid #8 FUEL SYSTEM

(fuel pressure)

Low Fuel Pressure-Condition

- Low fuel
- Fuel filter plugged
- Fuel supply line plugged
- Lift fuel pump - insufficient fuel supply
- Fuel pump (lift or module) - internally plugged
- Pressure regulator not functioning properly inside fuel pump module.

Diagnostic Aid #9 BASIC ENGINE

(cranks but will not run)

Condition

- Refer to basic engine troubleshooting charts within Troubleshooting.

EFI Diagnostic Flow Diagram

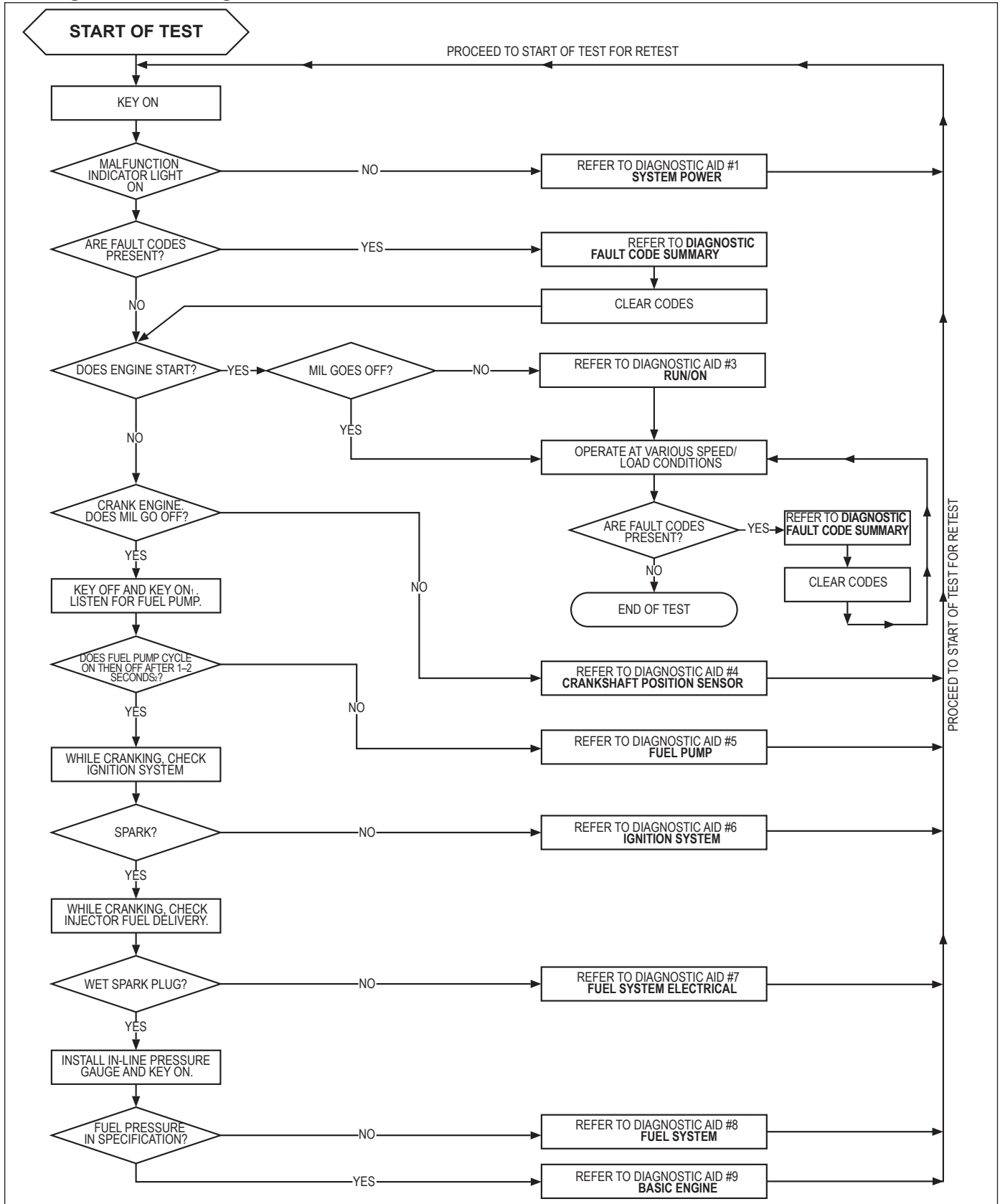

1. After turning key to OFF, wait 10 seconds before turning to ON to allow ECU to go to sleep.
2. Fuel pump module can be heard or a vibration can be felt to establish pump cycle. Fuel pump module will run for one 4-6 second cycle when ECU wakes up after being asleep.

Governor System

GOVERNOR

Governed speed setting is determined by position of throttle control. It can be variable or constant, depending on engine application.

Governor is designed to hold engine speed constant under changing load conditions. Most engines are equipped with a centrifugal flyweight mechanical governor. Governor gear/flyweight mechanism of mechanical governor is mounted inside crankcase and is driven off gear on camshaft.

Governor Components

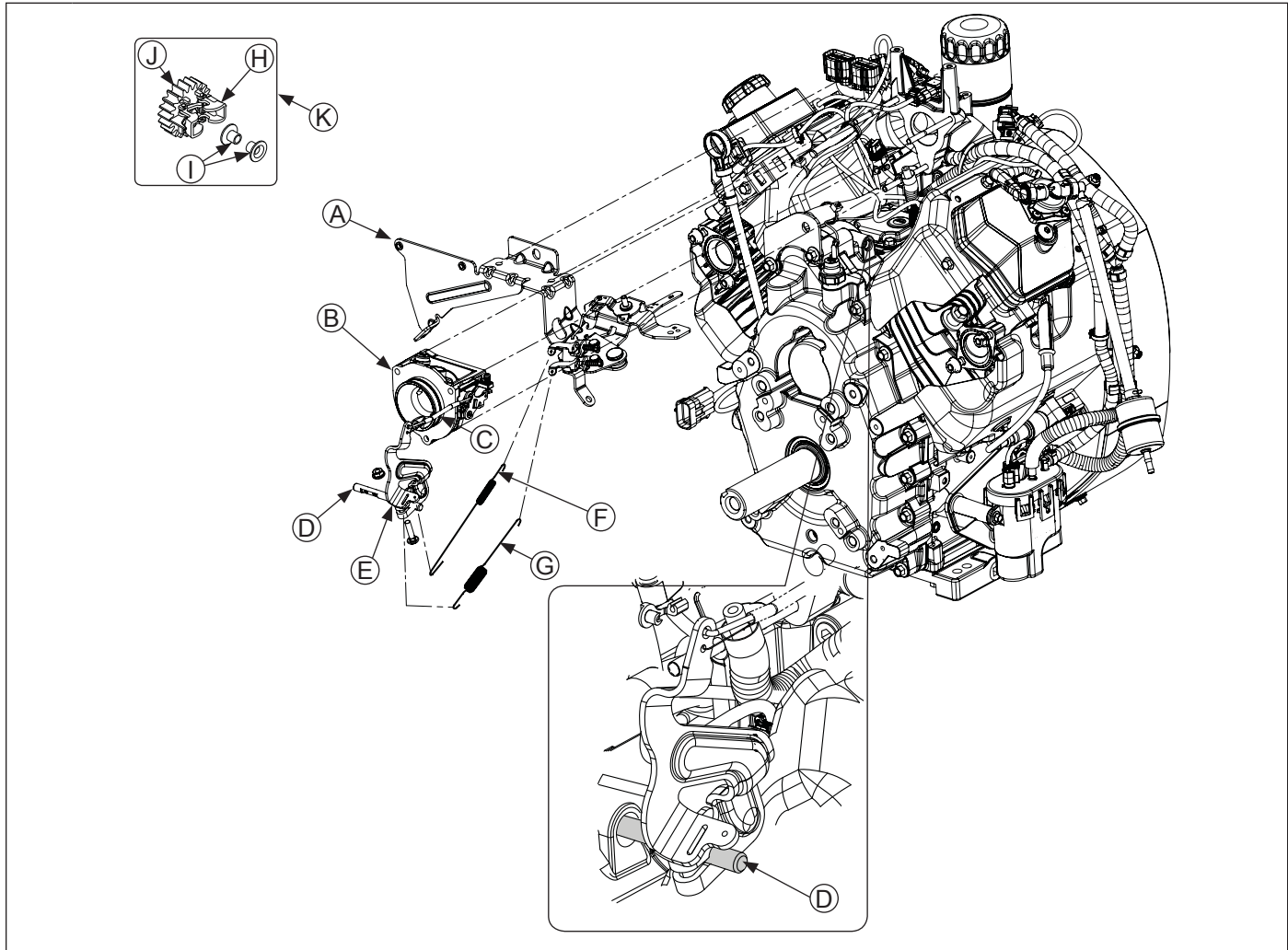

A	Control Bracket	B	Throttle Body	C	Throttle Linkage and Linkage Spring	D	Cross Shaft
E	Governor Arm	F	Governor Spring	G	Governed Idle Spring	H	Flyweight
I	Regulating Pin	J	Governor Gear	K	Inside Engine		

This governor design works as follows:

- Centrifugal force acting on rotating governor gear assembly causes flyweights to move outward as speed increases. Governor spring tension moves them inward as speed decreases.
- As flyweights move outward, they cause regulating pin to move outward.
- Regulating pin contacts tab on cross shaft causing shaft to rotate.
- One end of cross shaft protrudes through crankcase. Rotating action of cross shaft is transmitted to throttle lever of throttle body through external throttle linkage.
- When engine is at rest, and throttle is in fast position, tension of governor spring holds throttle plate open. When engine is operating, governor gear assembly is rotating. Force applied by regulating pin against cross shaft tends to close throttle plate. Governor spring tension and force applied by regulating pin balance each other during operation, to maintain engine speed.
- When load is applied and engine speed and governor gear speed decreases, governor spring tension moves governor arm to open throttle plate wider. This allows more fuel into engine, increasing engine speed. As speed reaches governed setting, governor spring tension and force applied by regulating pin will again offset each other to hold a steady engine speed.

Governor Adjustments

NOTE: Do not tamper with governor setting. Overspeed is hazardous and could cause personal injury.

Initial Adjustment Procedure Make this adjustment whenever governor arm is loosened or removed from cross shaft. Adjust as follows:

1. Make sure throttle linkage is connected to governor arm and throttle lever on throttle body.
2. Loosen nut holding governor lever to cross shaft.
3. Move governor lever toward throttle body as far as it will go (wide open throttle) and hold in this position.
4. Insert a long thin rod or tool into hole on cross shaft and rotate shaft clockwise (viewed from end) as far as it will turn, then torque nut to 7.1 N·m (63 in. lb.).

Lubrication System

This engine uses a full pressure lubrication system which delivers oil under pressure to crankshaft, camshaft, connecting rod bearing surfaces, and hydraulic valve lifters.

A high-efficiency gerotor oil pump maintains high oil flow and oil pressure, even at low speeds and high operating temperatures. A pressure relief valve limits maximum pressure of system. Closure plate must be removed to service oil pickup, pressure relief valve, and oil pump.

Lubrication Components

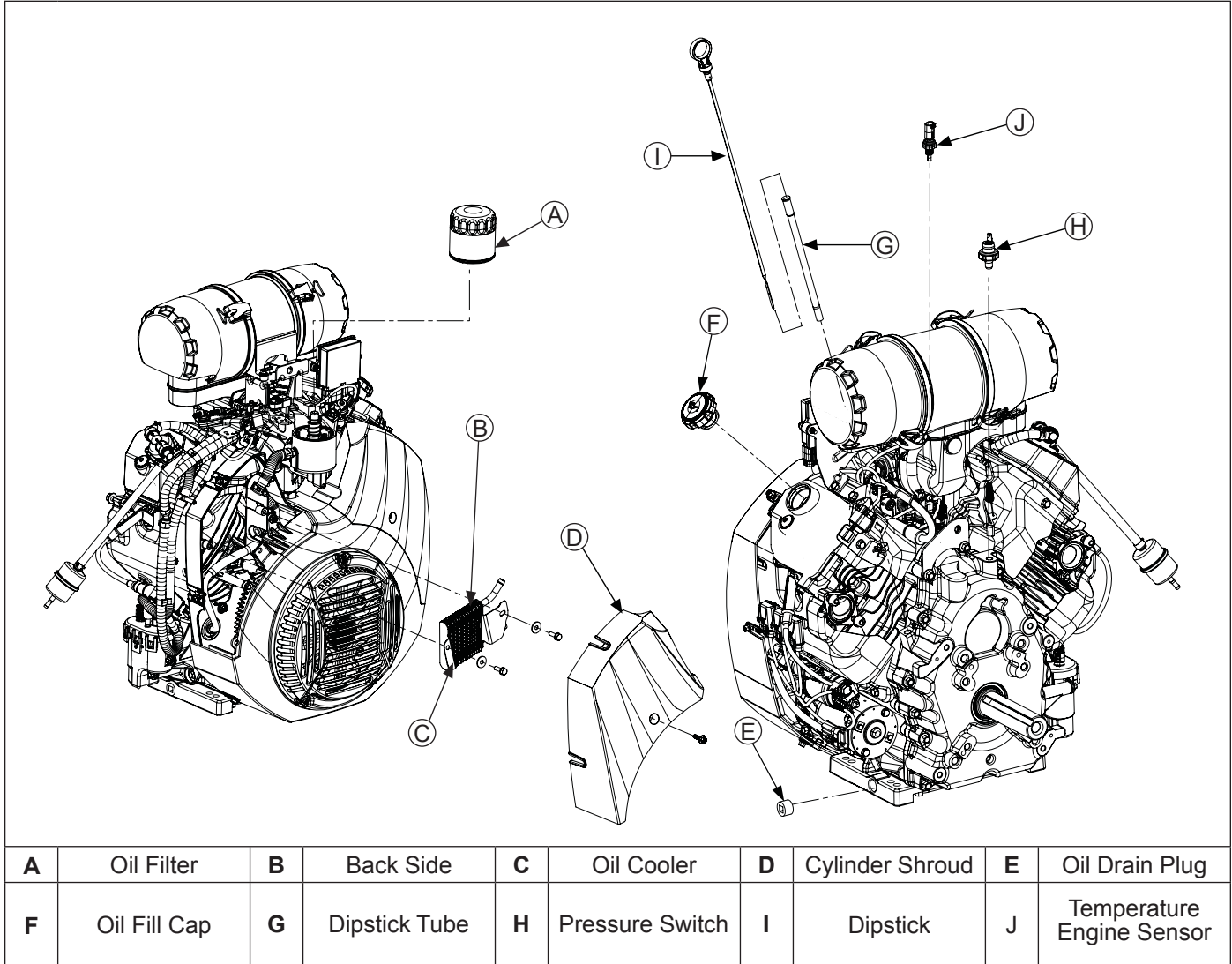

OIL RECOMMENDATIONS

Refer to Maintenance.

CHECK OIL LEVEL

NOTE: To prevent extensive engine wear or damage, never run engine with oil level below or above operating range indicator on dipstick.

Ensure engine is cool and level. Clean oil fill/dipstick areas of any debris.

1. Remove dipstick; wipe oil off .
2. Reinsert dipstick into tube; press completely down.
3. Remove dipstick; check oil level. Level should be at top of indicator on dipstick.
4. If oil is low on indicator, add oil up to top of indicator mark.
5. Reinstall and secure dipstick.

CHANGE OIL AND FILTER

Change oil while engine is warm.

1. Clean area around oil fill cap/dipstick and drain plug. Remove drain plug and oil fill cap/dipstick. Allow oil to drain completely.
2. Clean area around oil filter; remove filter; wipe off mounting surface. Reinstall drain plug and torque to 21.4 N·m (16 ft. lb.).
3. Place new filter in shallow pan with open end up. Fill with new oil until oil reaches bottom of threads. Allow 2 minutes for oil to be absorbed by filter material.
4. Apply a thin film of clean oil to rubber gasket on new filter.
5. Refer to instructions on oil filter for proper installation.
6. Fill crankcase with new oil. Level should be at top of indicator on dipstick.
7. Reinstall oil fill cap/dipstick and tighten securely.
8. Start engine; check for oil leaks. Stop engine; correct leaks. Recheck oil level.
9. Dispose of used oil and filter in accordance with local ordinances.

OIL COOLER

NOTE: Oil cooler is mounted under cylinder shroud. Removal of cylinder shroud is necessary to access oil cooler.

1. Clean fins with a brush or compressed air.
2. Remove screws securing oil cooler and tilt to clean back side.
3. Reinstall oil cooler and torque to 2.3 N·m (21 in. lb.).

OIL SENTRY™ (if equipped)

This switch is designed to prevent engine from starting in a low oil or no oil condition. Oil Sentry™ may not shut down a running engine before damage occurs. In some applications this switch may activate a warning signal. Read your equipment manuals for more information.

Oil Sentry™ pressure switch is installed in closure plate pressure port. On engines not equipped with Oil Sentry™ installation hole is sealed with a 1/8-27 N.P.T.F. pipe plug.

Installation

1. Apply pipe sealant with Teflon® (Loctite® PST® 592™ Thread Sealant or equivalent) to threads of switch.
2. Install switch into tapped hole in closure plate.
3. Torque switch to 10.7 N·m (95 in. lb.).

Testing

Compressed air, a pressure regulator, pressure gauge, and a continuity tester are required to test switch.

1. Connect continuity tester across blade terminal and metal case of switch. With 0 psi pressure applied to switch, tester should indicate continuity (switch closed).
2. Gradually increase pressure to switch. As pressure increases through range of 7-11 psi tester should indicate a change to no continuity (switch open). Switch should remain open as pressure is increased to 90 psi maximum.
3. Gradually decrease pressure through range of 7-11 psi. Tester should indicate a change to continuity (switch closed) down to 0 psi.
4. Replace switch if it does not operate as specified.

Electrical System

SPARK PLUGS



CAUTION Electrical

Shock can cause injury. Do not touch wires while engine is running.

Spark Plug Component and Details

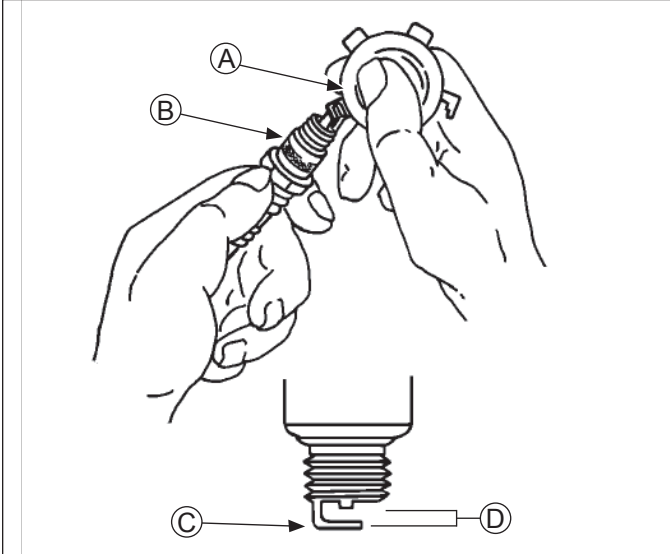

A	Wire Gauge	B	Spark Plug
C	Ground Electrode	D	Gap

NOTE: Do not clean spark plug in a machine using abrasive grit. Some grit could remain in spark plug and enter engine causing extensive wear and damage.

Engine misfire or starting problems are often caused by a spark plug that has improper gap or is in poor condition.

Engine is equipped with following spark plugs:

Gap	0.76 mm (0.030 in.)
Thread Size	14 mm
Reach	19.1 mm (3/4 in.)
Hex Size	15.9 mm (5/8 in.)

Refer to Maintenance for Repairs/Service Parts.

Service

Clean out spark plug recess. Remove plug and replace.

1. Check gap using wire feeler gauge. Adjust gap to 0.76 mm (0.030 in.).
2. Install plug into cylinder head.
3. Torque plug to 27 N·m (20 ft. lb.).

Inspection

Inspect each spark plug as it is removed from cylinder head. Deposits on tip are an indication of general condition of piston rings, valves, and throttle body.

Normal and fouled plugs are shown in following photos:

Normal

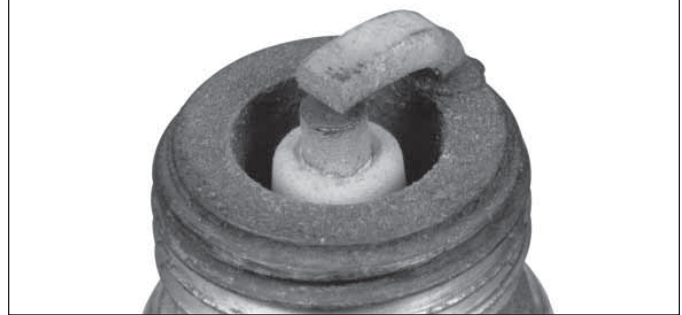

Plug taken from an engine operating under normal conditions will have light tan or gray colored deposits. If center electrode is not worn, plug can be set to proper gap and reused.

Worn



On a worn plug, center electrode will be rounded and gap will be greater than specified gap. Replace a worn spark plug immediately.

Wet Fouled



A wet plug is caused by excess fuel or oil in combustion chamber. Excess fuel could be caused by a restricted air cleaner, a throttle body problem, or operating engine with too much choke. Oil in combustion chamber is usually caused by a restricted air cleaner, a breather problem, worn piston rings, or valve guides.

Carbon Fouled



Soft, sooty, black deposits indicate incomplete combustion caused by a restricted air cleaner, over rich carburetion, weak ignition, or poor compression.

Overheated



Chalky, white deposits indicate very high combustion temperatures. This condition is usually accompanied by excessive gap erosion. Lean throttle body settings, an intake air leak, or incorrect spark timing are normal causes for high combustion temperatures.

BATTERY

A 12-volt battery with 400 cold cranking amps (cca) is generally recommended for starting in all conditions. A smaller capacity battery is often sufficient if an application is started only in warmer temperatures. Refer to following table for minimum capacities based on anticipated ambient temperatures. Actual cold cranking requirement depends on engine size, application, and starting temperatures. Cranking requirements increase as temperatures decrease and battery capacity shrinks. Refer to equipment's operating instructions for specific battery requirements.

Battery Size Recommendations

Temperature	Battery Required
Above 32°F (0°C)	300 cca minimum
0°F to 32°F (-18°C to 0°C)	300 cca minimum
-5°F to 0°F (-21°C to -18°C)	300 cca minimum
-10°F (-23°C) or below	400 cca minimum

If battery charge is insufficient to turn over engine, recharge battery.

Battery Maintenance

Regular maintenance is necessary to prolong battery life.

Battery Test

To test battery, follow manufacturer's instructions.

FUSES

This engine has 3 blade type automotive fuses. Replacement fuses must have same rating as blown fuse. Use fuse chart below to determine correct fuse.

Wire Color	Fuse Rating
2 Purple Wires	30-amp Fuse
1 Red Wire w/Black Stripe 1 Red Wire w/White Stripe	10-amp Fuse
2 Red Wires	10-amp Fuse

Fuse Replacement

1. Shut engine off and remove key.
2. Locate fuse holders.
3. Remove fuse cover and pull out fuse. Inspect condition of fuse holder.
4. Inspect fuse for a solid fusible link or a broken fusible link. Replace fuse if fusible link is broken. If you are not sure if fusible link is broken, replace fuse.
5. Insert fuse into fuse holder until it is seated properly. Install fuse cover.
6. If replacement fuse fails, there is a problem within circuit. Diagnostics are required. Identify which circuit is affected (see EFI System for electrical schematic) by identifying failed fuse/circuit. Perform troubleshooting procedures appropriate for circuit fuse that failed.
7. Install fuse holder into fuse cover.

Electrical System

Test Ignition Systems

NOTE: If engine starts or runs during testing, you may need to ground kill lead to shut it down. Because you have interrupted kill circuit, it may not stop using switch.

Isolate and verify trouble is within engine.

1. If Rehlko diagnostic software is available, review "Safety System Active" status in Data Display screen. If yes is displayed, equipment safety circuit is active (seat switch/PTO switch/Safety interlocks, etc.). This must be corrected prior to continuing testing. If diagnostic software is not available, locate connectors where wiring harnesses from engine and equipment are joined. Separate connectors and remove white kill lead from engine connector. Rejoin connectors and position or insulate kill lead terminal so it cannot touch ground. Try to start engine to verify whether reported problem is still present.

Condition	Possible Cause	Conclusion
Problem goes away.	Electrical System	Check key switch, wires, connections, safety interlocks, etc.
Problem persists.	Ignition or Electrical System	Leave kill lead isolated until all testing is completed. Identify white kill lead of engine wiring harness connector. Establish a connection to a known good ground location. Engine should kill completely. If not or only one cylinder is affected, test ignition coils.

Test for Spark

NOTE: If 2 testers are available, testing can be performed simultaneously for both cylinders. However, if only 1 tester is available, 2 individual tests must be performed. Side not being tested must have spark plug lead connected or grounded. Do not crank engine or perform tests with 1 spark plug lead disconnected and not grounded, or permanent coil damage may occur.

1. With engine stopped, disconnect 1 spark plug lead. Connect spark plug lead to post terminal of spark tester and attach tester clip to a good engine ground.
2. Crank engine over, establishing a minimum of 350-450 RPM, and observe tester(s) for spark.
3. Repeat spark test on opposite cylinder if cylinders are being tested individually.

Condition	Possible Cause	Conclusion
One side is not firing.	Wiring and Connections	Check all wiring, connections, and terminals on that side. If wiring is okay, replace ignition coil and retest for spark.
Tester shows spark but engine misses or won't run on that cylinder.	Spark Plug(s)	Try new spark plug(s).
Neither side is firing.	Ignition Switch/EFI System/Kill Lead	Recheck position of ignition switch and check for shorted kill lead.
Both cylinders have good spark but engine runs poorly or existing plug condition is questionable.	Spark Plug(s)	Install new spark plug(s) and retest engine performance.
1 cylinder has good spark and other cylinder has no or intermittent spark.	Ignition	Test ignition coils and connections.

Wire Diagram-8-pin Connector and Key Switch Auxiliary Harness

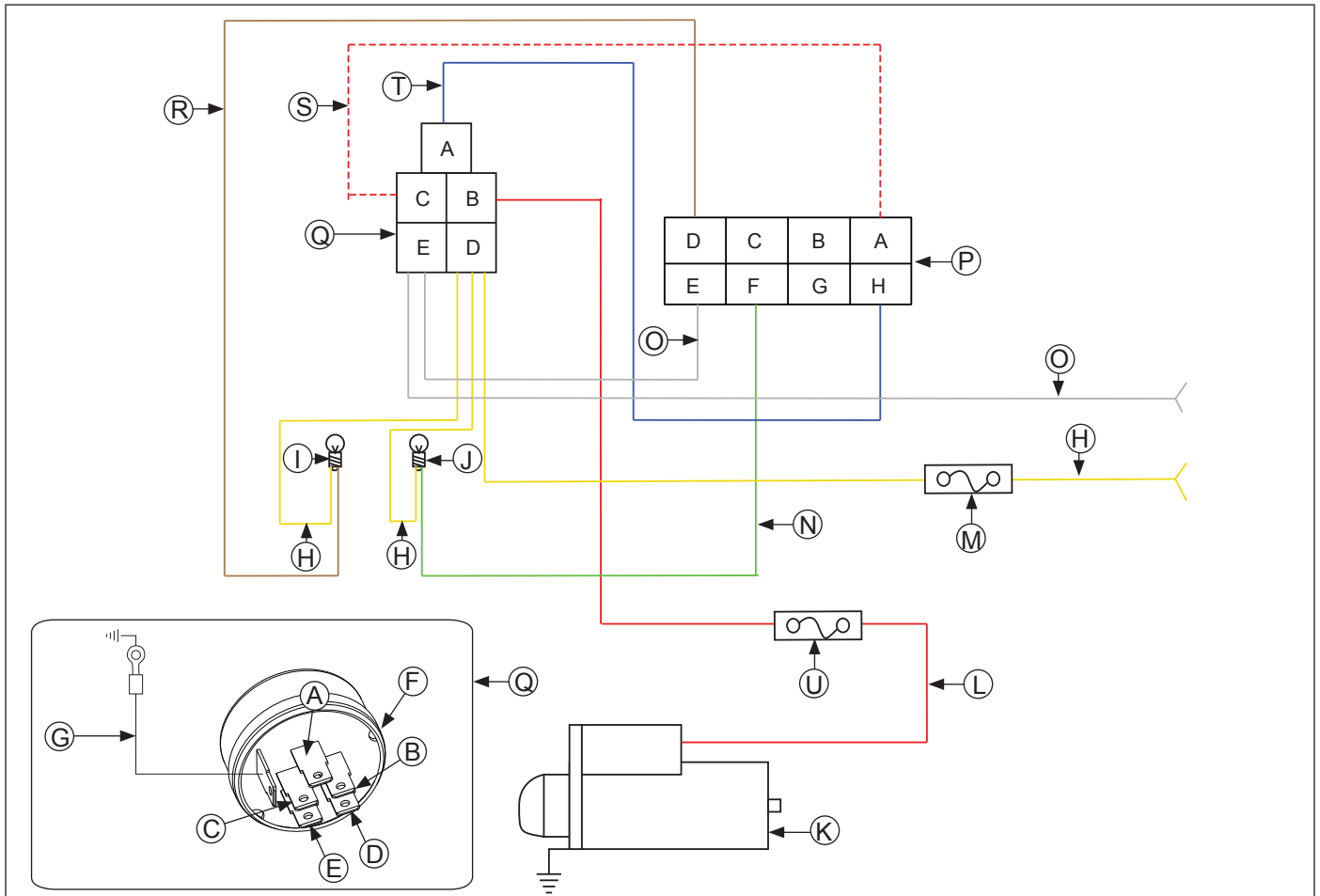

A	To Starter	B	ECU Power	C	12V Constant	D	Switch Power Accessories
E	Ground to Kill	F	Key Switch	G	Ground	H	Yellow
I	MIL 15 Amp	J	Oil	K	Starter	L	Red
M	Fuse	N	Green	O	White	P	8-Pin Connector
Q	5-Pin Connector	R	Tan	S	Red with White Stripe	T	Blue
U	25 Amp Fuse						

Electrical System

BATTERY CHARGING SYSTEM

NOTE: Observe following guidelines to avoid damage to electrical system and components:

- Make sure battery polarity is correct. A negative (–) ground system is used.
- Disconnect rectifier-regulator plug and/or wiring harness plug before doing any electric welding on equipment powered by engine. Disconnect all other electrical accessories in common ground with engine.
- Prevent stator (AC) leads from touching or shorting while engine is running. This could damage stator.

NOTE: 20 amp charging systems use a 15 amp stator with a 25 amp rectifier-regulator.

These engines are equipped with a 20 or 25 amp regulated charging system.

20/25 Amp Regulated Charging System

Stator

Stator is mounted on crankcase behind flywheel. Follow procedures in Disassembly and Reassembly if stator replacement is necessary.

Rectifier-Regulator

NOTE: When installing rectifier-regulator, take note of terminal positions and install plug correctly.

NOTE: Disconnect all electrical connections attached to rectifier-regulator. Testing may be performed with rectifier-regulator mounted or loose. Repeat applicable test procedure 2 or 3 times to determine condition of part.

Rectifier-regulator is mounted on backing shroud assembly. To replace it, disconnect plug, remove mounting screws, and ground lead.

Testing rectifier-regulator may be performed as follows, using appropriate rectifier-regulator tester.

To test 20/25 amp rectifier-regulators:

1. Connect single lead adapter in between B+ (center) terminal of rectifier-regulator being tested and squared single end of tandem adapter lead.
2. Connect tester ground lead (with spring clamp) to body of rectifier-regulator.
3. Connect red lead and 1 black lead to terminals on open end of tandem adapter lead (connections are not location specific).
4. Connect remaining black lead from tester to 1 outer AC terminal on rectifier-regulator.
5. Plug tester into proper AC outlet/power for tester being used. Turn on power switch. POWER light should be illuminated and 1 of 4 status lights may be on as well. This does not represent condition of part.
6. Press TEST button until a click is heard and then release. Momentarily 1 of 4 lights will illuminate indicating partial condition of part.

Condition	Conclusion
OK (green) light comes on and stays steady.	20/25 amp Disconnect tester black lead attached to 1 AC terminal and reconnect it to other AC terminal. Repeat test. If OK (green) light comes on again, part is good and may be used.
NOTE: A flashing LOW light can also occur as a result of an inadequate ground lead connection. Make certain connection location is clean and clamp is secure. Other lights come on.	Rectifier-regulator is faulty and should not be used.

20/25 Amp Battery Charging Systems

NOTE: Always zero ohmmeter on each scale before testing to ensure accurate readings. Voltage tests should be made with engine running at 3600 RPM with no load. Battery must be good and fully charged.

When problems occur in keeping battery charged or battery charges at high rate, charging system or battery might be causing problems.

To test charging system for no charge to battery:

1. Insert an ammeter in B+ lead from rectifier-regulator. With engine running at 3600 RPM and B+ (at terminal on rectifier-regulator) to ground using a DC voltmeter. If voltage is 13.8 volts or more, place a minimum load of 5 amps (turn on lights if 60 watts or more, or place a 2.5 ohm, 100 watt resistor across battery terminals) on battery to reduce voltage. Observe ammeter.

Condition	Conclusion
Charge rate increases when load is applied.	Charging system is OK and battery was fully charged.
Charge rate does not increase when load is applied.	Test stator and rectifier-regulator (steps 2 and 3).

2. Remove connector from rectifier-regulator. With engine running at 3600 RPM, measure AC voltage across stator leads using an AC voltmeter.

Condition	Conclusion
Voltage is 28 volts or more.	Stator is OK. Rectifier-regulator is faulty; replace.
Voltage is less than 28 volts.	Stator is faulty; replace. Test stator further using an ohmmeter (steps 3 and 4).

3. With engine stopped, measure resistance across stator leads using an ohmmeter.

Condition	Conclusion
Resistance is 0.1/0.2 ohms.	Stator is OK.
Resistance is 0 ohms.	Stator is shorted; replace.
Resistance is infinity ohms.	Stator is open; replace.

4. With engine stopped, measure resistance from each stator lead to ground using an ohmmeter.

Condition	Conclusion
Resistance is infinity ohms (no continuity).	Stator is OK (not shorted to ground).
Resistance (or continuity) measured.	Stator leads are shorted to ground; replace.

To test charging system for battery continuously charging at high rate:

1. With engine running at 3600 RPM, measure voltage from B+ lead to ground using a DC voltmeter.

Condition	Conclusion
Voltage is 14.7 volts or less.	Charging system is OK. Battery is unable to hold charge; service or replace.
Voltage is more than 14.7 volts.	Faulty rectifier-regulator; replace.

Starter System

NOTE: Do not crank engine continuously for more than 10 seconds. Allow a 60 second cool-down period between starting attempts. Failure to follow these guidelines can burn out starter motor.

NOTE: If engine develops sufficient speed to disengage starter but does not keep running (a false start), engine rotation must be allowed to come to a complete stop before attempting to restart engine. If starter is engaged while flywheel is rotating, starter pinion and flywheel ring gear may clash and damage starter.

NOTE: If starter does not crank engine, shut off starter immediately. Do not make further attempts to start engine until condition is corrected.

NOTE: Do not drop starter or strike starter frame. Doing so can damage starter.

NOTE: Battery must be tested and confirmed acceptable prior to troubleshooting starter system. Follow battery or OEM battery testing procedures.

Engines in this series use solenoid shift starters.

Troubleshooting-Starting Difficulties

Condition	Possible Cause	Conclusion
Starter does not energize.	Battery	Check specific gravity of battery and battery state of charge. If low, recharge or replace battery as necessary.
	Wiring	Clean corroded connections and tighten loose connections. Replace wires in poor condition and with frayed or broken insulation.
	Starter Switch or Solenoid	By-pass switch or solenoid with a jumper wire. If starter cranks normally, replace faulty components. Consult with OEM electrical system service procedures for OEM related component diagnostics. Perform solenoid test procedure.
Starter energizes but turns slowly.	Battery	Check specific gravity of battery and battery state of charge. If low, recharge or replace battery as necessary.
	Transmission or Engine	Make sure clutch or transmission is disengaged or placed in neutral. This is especially important on equipment with hydrostatic drive. Transmission must be exactly in neutral to prevent resistance which could keep engine from starting. Check for seized engine components such as bearings, connecting rod, and piston.

SOLENOID SHIFT STARTERS

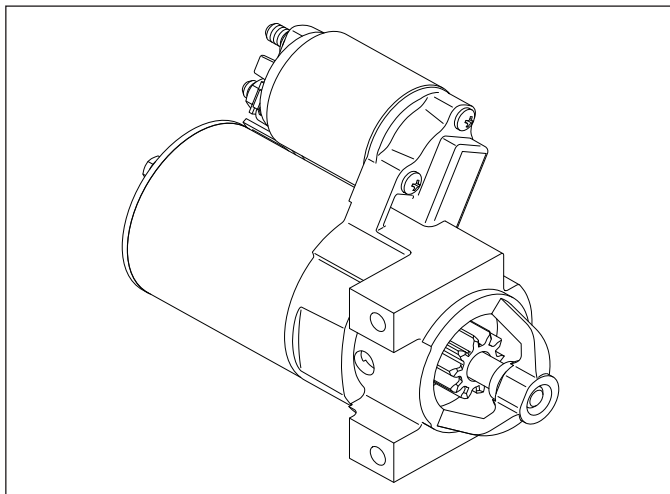

When power is applied to starter electric solenoid moves drive pinion out onto drive shaft and into mesh with flywheel ring gear. When pinion reaches end of drive shaft it rotates flywheel and cranks engine.

When engine starts and start switch is released, starter solenoid is deactivated, drive lever moves back, and drive pinion moves out of mesh with ring gear into retracted position.

Inspection

Drive Pinion

Check and inspect following areas:

- Pinion teeth for abnormal wear or damage.
- Surface between pinion and clutch mechanism for nicks or irregularities which could cause seal damage.
- Check drive clutch by holding clutch housing and rotating pinion. Pinion should rotate in only 1 direction.

Solenoid Tests

NOTE: Please perform following testing as near to conditions during failure.

Before Starting

- Disable ignition system: with key off, unplug EFI Electronic Control Unit (ECU) or remove both 10 amp (red) engine mounted fuses.
- Battery voltage should be tested and must be at 12.4 VDC or higher. Do not proceed if battery voltage is less than 12.4 VDC as battery should be charged.
- Test meter leads before use. (Set meter to Ohms and check for resistance reading of less than 0.5 Ohm.)
- If available, use clamping meter leads to assist with testing.
- Set meter to next highest voltage scale that includes 12 VDC.
- When taking readings, allow meter to stabilize before recording. Reading should stabilize after 3 to 5 seconds. If reading continues to drop while cranking, stop test and perform a battery load test.

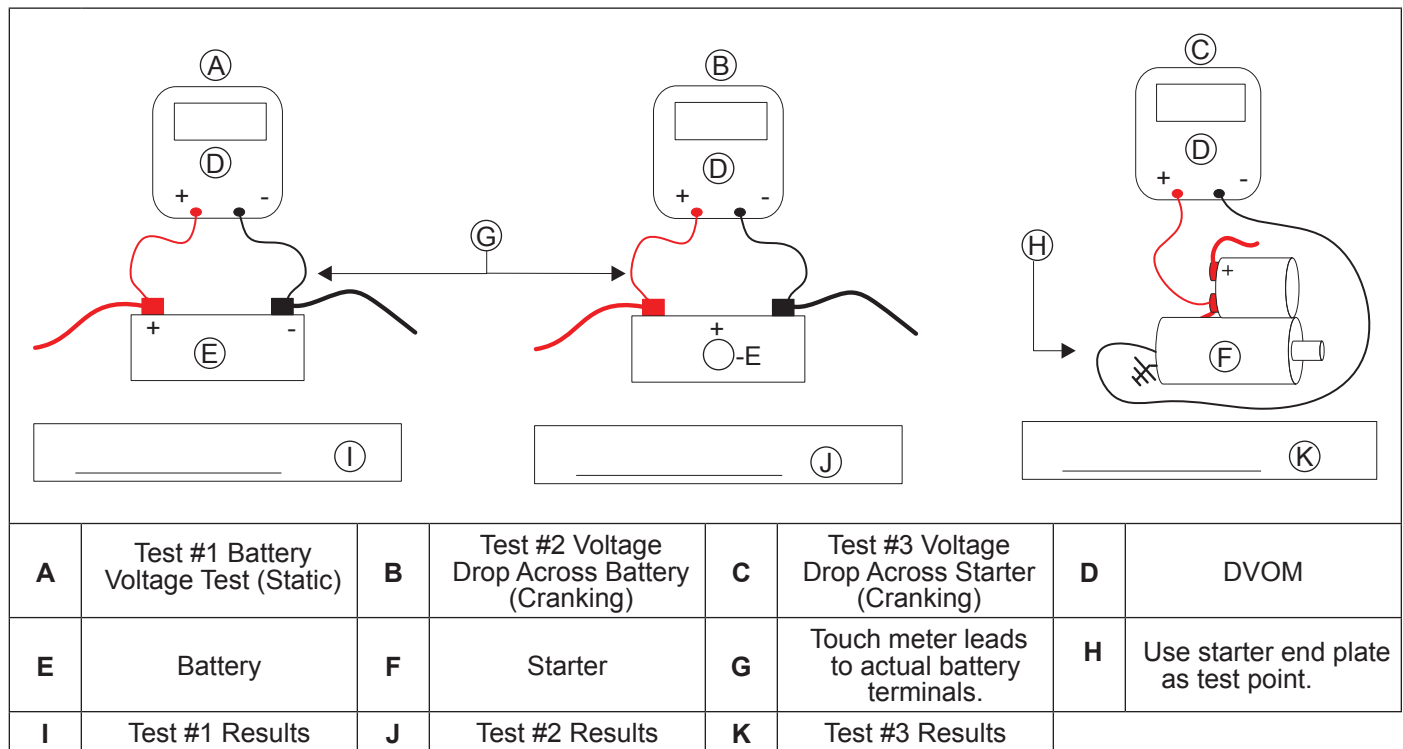

Test 1 Conclusions

- If battery voltage is above 12.4 VDC continue to Test 2.
- If voltage is below 12.4 VDC, charge battery and retest.
- If battery will not hold a charge it should be replaced before continuing test or replacing starter.

Test 2 Conclusions

- If battery cranking voltage is above 9.0 VDC continue to Test 3.
- If battery cranking voltage is below 9.0 VDC you should check battery by using a load tester. Also check for external engine load.

Test 3 Conclusions

- If difference between test 2 and test 3 is greater than 1 VDC check all positive and negative electrical connections for corrosion and/or loose fasteners in starter circuit.

Disassembly/Inspection and Service

	⚠ WARNING	Before working on engine or equipment, disable engine as follows: 1) Disconnect spark plug lead(s). 2) Disconnect negative (-) battery cable from battery.
	Accidental Starts can cause severe injury or death. Disconnect and ground spark plug lead(s) before servicing.	

External Engine Components

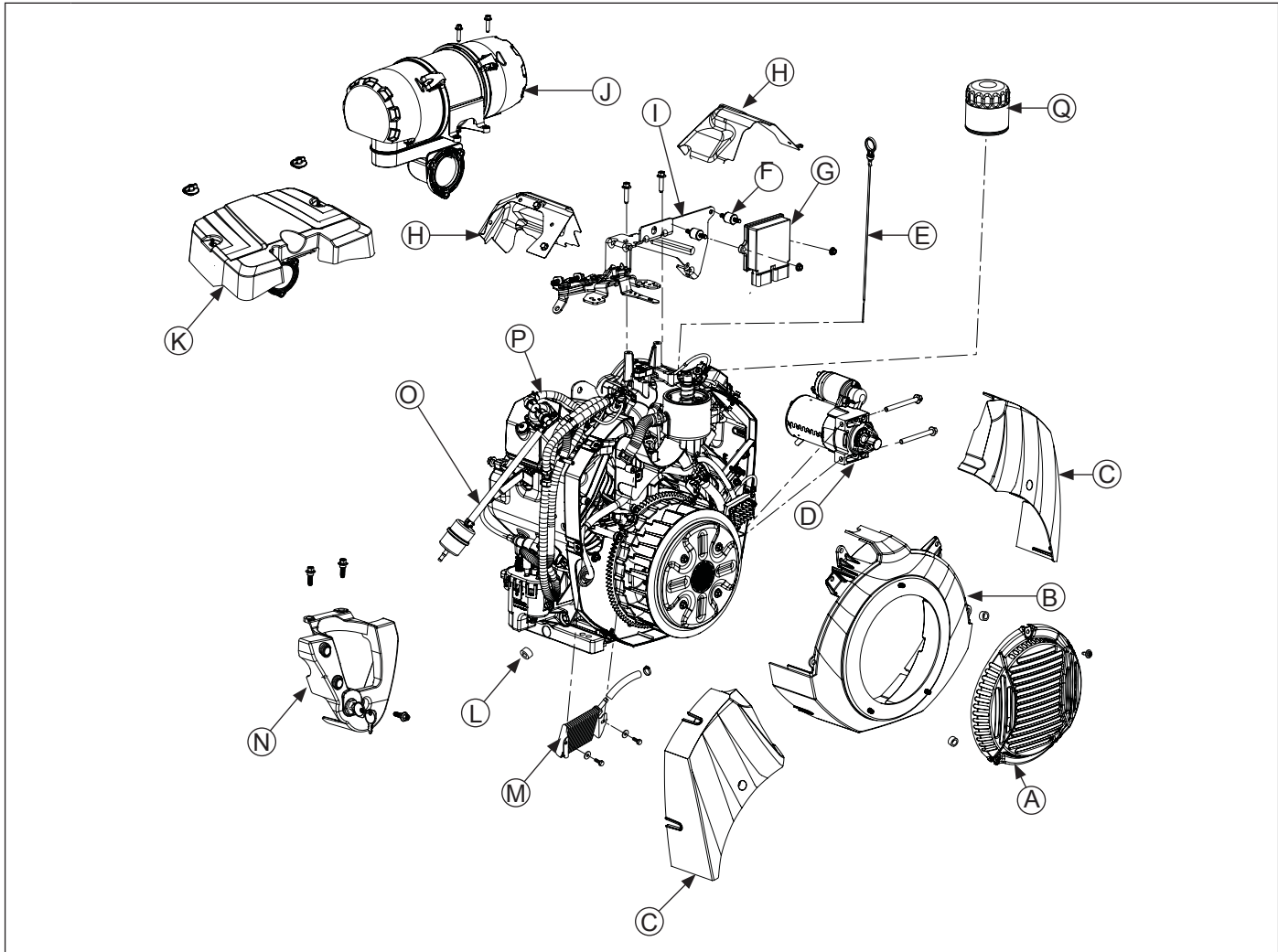

A	Fixed Guard	B	Blower Housing	C	Cylinder Shroud	D	Electric Starter
E	Dipstick	F	Electronic Control Unit (ECU)	G	Vibration Stud Isolator	H	Valley Baffle
I	Control Bracket	J	Heavy-Duty Air Cleaner	K	Low-Profile Air Cleaner	L	Drain Plug
M	Oil Cooler	N	Control Panel (if equipped)	O	Inlet Fuel Line	P	Outlet Fuel Line
Q	Oil Filter						

Disassembly/Inspection and Service

Clean all parts thoroughly as engine is disassembled. Only clean parts can be accurately inspected and gauged for wear or damage. There are many commercially available cleaners that will quickly remove grease, oil and grime from engine parts. When such a cleaner is used, follow manufacturer's instructions and safety precautions carefully.

Make sure all traces of cleaner are removed before engine is reassembled and placed into operation. Even small amounts of these cleaners can quickly break down lubricating properties of engine oil.

NOTE: This disassembly sequence removes some components in subassemblies to enable technician to perform internal engine servicing. Do not disconnect every EFI component.

Disconnect Spark Plug Leads

NOTE: Pull on boot only, to prevent damage to spark plug lead.

1. Disconnect leads from spark plugs.
2. Shut off fuel supply.

Drain Oil from Crankcase and Remove Oil Filter

1. Clean oil filter and housing area. Remove and discard oil filter.
2. Remove dipstick and 1 oil drain plug.
3. Allow ample time for oil to drain from crankcase.

Remove Muffler (if equipped)

NOTE: Unless oxygen sensor is damaged or malfunctioning, disassembly from muffler is unnecessary.

1. Disconnect oxygen sensor connector from wire harness.
2. Remove exhaust system and attaching hardware from engine. On engines equipped with a port liner, remove it now.

Remove Cylinder Shrouds and Blower Housing

1. Remove front mounting screw and loosen shoulder screws on each side. Remove cylinder shrouds.
2. Remove top mounting screws, loosen bottom screws, and separate blower housing from backing shroud. Fixed guard (if equipped) may be removed with blower housing.

Remove Electric Starter Motor

1. Disconnect leads from starter.
2. Remove screws and starter.

Remove Control Panel (if equipped)

NOTE: Unless control panel is damaged or malfunctioning, disassembly from engine is unnecessary.

1. Remove three screws securing control panel.
2. Disconnect 5-pin connector and ground terminal from key switch.
3. After noting where yellow, green, and tan wires are connected, carefully disconnect wire connectors and remove control panel.

Remove Air Cleaner Assembly

NOTE: Low-profile air cleaner is removed same way as heavy-duty air cleaner.

1. Disconnect breather hose from air cleaner.
2. Remove top air cleaner body support screws.
3. Remove air cleaner elbow nuts.
4. Remove air cleaner as an assembly from engine.

Remove Control Bracket and Governor Springs

NOTE: Unless ECU is damaged or malfunctioning, disassembly from control bracket is unnecessary.

1. Unhook governed idle and governor springs from controls on control bracket and governor lever. Note color, location, and position of each.
2. Unhook bushing, remove throttle linkage and linkage spring from governor lever, and remove bushing.
3. Disconnect Black and Grey electrical connectors from ECU.
4. Remove two screws and lift off control bracket.
5. Remove nuts from vibration stud isolators securing ECU module to control bracket and remove ECU module.
6. Loosen nut and remove governor lever from cross shaft.

Disassembly/Inspection and Service

Remove #1 Valley Baffle Dipstick Tube Mounting

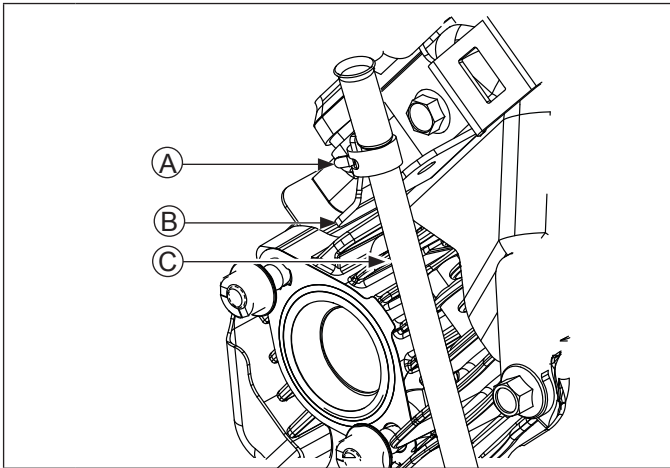

A	Spring Hose Clamp	B	Fuse Holder Bracket
C	Dipstick Tube		

1. Slide spring hose clamp upwards on dipstick tube.
2. On engines with control panel, remove fuses from covers located in fuse holder bracket.
3. Remove two screws from fuse holder bracket that secure valley baffle to cylinder head.
4. Carefully remove clip from fuse holder bracket.
5. Remove third screw securing valley baffle, remove clips securing ECU plugs, and remove baffle.

Remove #2 Valley Baffle

1. Carefully remove clip securing low pressure fuel lines to valley baffle. Access clip through backing shroud.
2. Remove two screws that secure valley baffle to cylinder head and remove baffle.

Remove Oil Sentry™ (if equipped)

NOTE: Unless Oil Sentry™ switch is damaged or malfunctioning, disassembly from closure plate is unnecessary.

1. Disconnect lead from Oil Sentry™ switch.
2. Remove Oil Sentry™ switch from closure plate.

Remove Oil Cooler

NOTE: New clamps are recommended any time disassembly is performed, or if clamps have been loosened (expanded) several times.

NOTE: Make note of clamp orientation for reassembly.

1. Remove oil cooler mounting screws. Do not lose any washers (if used).
2. Loosen clamps and disconnect hoses from oil cooler.

Disconnect Fuel Lines from Fuel Pump Module (FPM) and Fuel Pump



⚠ WARNING

Explosive Fuel can cause fires and severe burns.
Do not fill fuel tank while engine is hot or running.

Gasoline is extremely flammable and its vapors can explode if ignited. Store gasoline only in approved containers, in well ventilated, unoccupied buildings, away from sparks or flames. Spilled fuel could ignite if it comes in contact with hot parts or sparks from ignition. Never use gasoline as a cleaning agent.

FPM Components

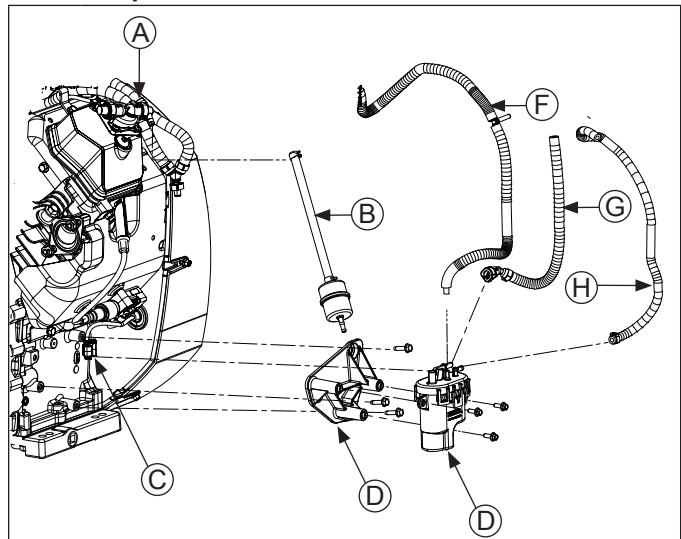

A	Fuel Pump	B	Inlet Fuel Line	
C	Electrical Connector	D	FPM Baffle	
E	FPM		F	Vent Hose
G	High Pressure Fuel Line	H	Outlet Fuel Line to FPM	

NOTE: Do not cut Oetiker clamp unless fuel line or FPM are being replaced.

1. Disconnect fuel lines at fuel pump.
2. Fuel pump will be removed with valve cover. Refer to valve cover removal procedure.
3. Lift grey locking tab and squeeze to disconnect electrical connector.
4. Using Hose Removal Tool (see Tools and Aids), disconnect vent hose from top of FPM.
5. Wrap a shop towel completely around high pressure fuel line connector. Press release button and slowly pull connector away from FPM, allowing shop towel to absorb any residual fuel in high pressure fuel line. Any spilled fuel must be wiped up immediately.
6. Keep inlet fuel line attached at FPM.

Intake Manifold Components

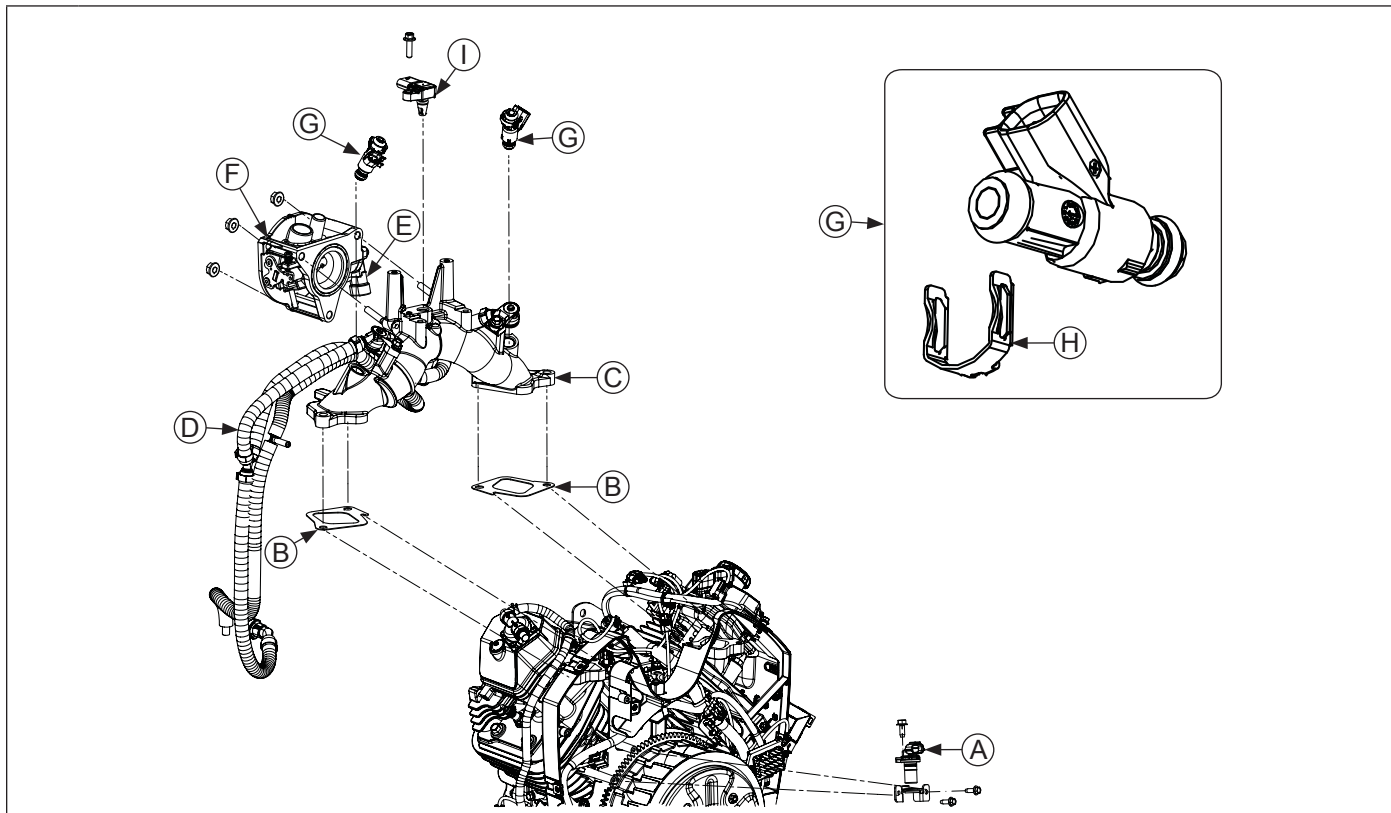

A	Crankshaft Position Sensor	B	Intake Manifold Gasket	C	Intake Manifold	D	Fuel Rail
E	TPS Sensor	F	Throttle Body	G	Fuel Injector	H	Metal Retaining Clip
I	TMAP Sensor						

Remove Temperature/Manifold Absolute Pressure (TMAP) Sensor

NOTE: Unless TMAP sensor is damaged or malfunctioning, disassembly from intake manifold is unnecessary.

1. With a screwdriver, slide locking tab on electrical connector.
2. Detach connector.
3. Remove screw and pull TMAP sensor out of intake manifold.

Remove Throttle Body

NOTE: Mark position of fuel injector electrical connector before removing.

1. Disconnect throttle position sensor connector.
2. Disconnect vent hose from throttle body.
3. Slide throttle body off studs.
4. Using a permanent marker, place a 1 or 2 on each electrical connector, designating appropriate cylinder head.
5. Disconnect fuel injector electrical connectors.

Remove Fuel Injectors

NOTE: Unless fuel injectors are damaged or malfunctioning, disassembly from intake manifold is unnecessary.

NOTE: Make note of position of fuel injector before removing.

1. Remove screw and pull injector out of intake manifold.
2. When removed, pull metal retaining clip connecting fuel injector to fuel injector cap. There may be some fuel left in line. Any spilled fuel must be cleaned up immediately.

Disassembly/Inspection and Service

Remove Intake Manifold/Injectors/Fuel Rail/FPM Assembly

1. Carefully remove clip from #2 barrel bae.
2. Remove screws securing intake manifold to cylinder heads.
3. Remove screws securing FPM to baffle.
4. Remove screws securing FPM baffle to crankcase and remove baffle.
5. While holding FPM so fuel does not leak out, remove intake manifold assembly and intake manifold gaskets. Note position of gaskets for reassembly.

Remove Crankshaft Position Sensor

NOTE: Do not remove sensor from bracket unless sensor is being replaced.

1. Remove screws securing crankshaft position sensor bracket to crankcase posts.
2. Disconnect electrical connector from crankshaft position sensor.

Remove Oil Filter Housing

Oil Filter Housing Components

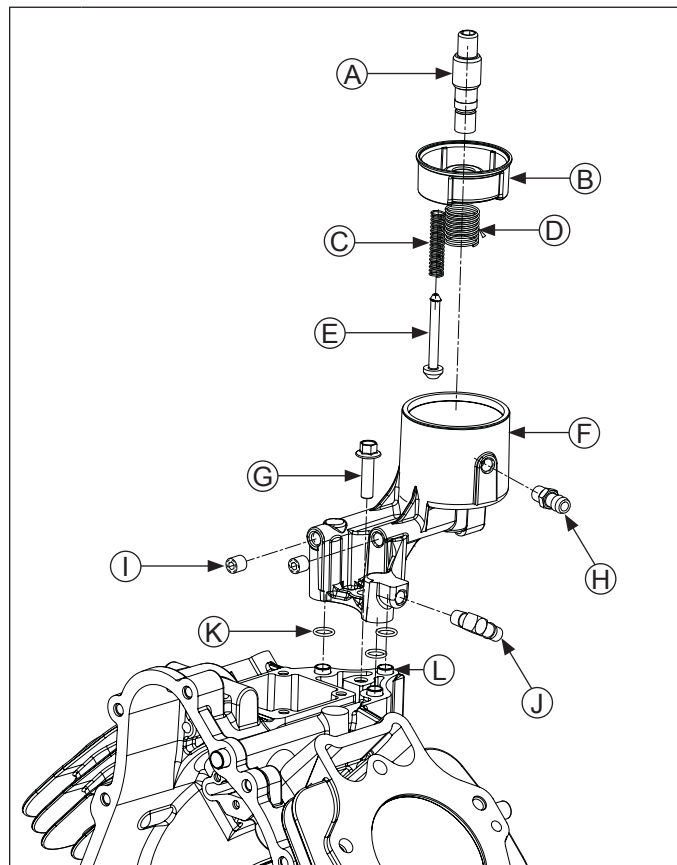

A	Oil Filter Nipple	B	Oil Filter Cup
C	Oil Filter Valve Spring	D	Oil Filter Cup Spring
E	Oil Filter Valve	F	Oil Filter Housing

G	Screw	H	Straight Fitting
I	Pipe Plug	J	Barbed Fitting
K	O-Ring	L	Dowel

NOTE: Further disassembly of oil filter housing assembly is not required unless being serviced individually. Follow substeps a, b, c and d.

Remove screw securing oil filter housing and individual O-rings to crankcase. Carefully separate parts. Perform following only if oil filter housing assembly requires individual servicing.

- a. Remove nipple from cup and oil filter housing.
- b. Remove oil filter cup and spring from housing.
- c. Remove rubber valve and spring from cup.
- d. If oil passages in housing require cleaning, remove pipe plug, barbed fitting, and O-rings.

Remove Debris Screen and Fan Option #1

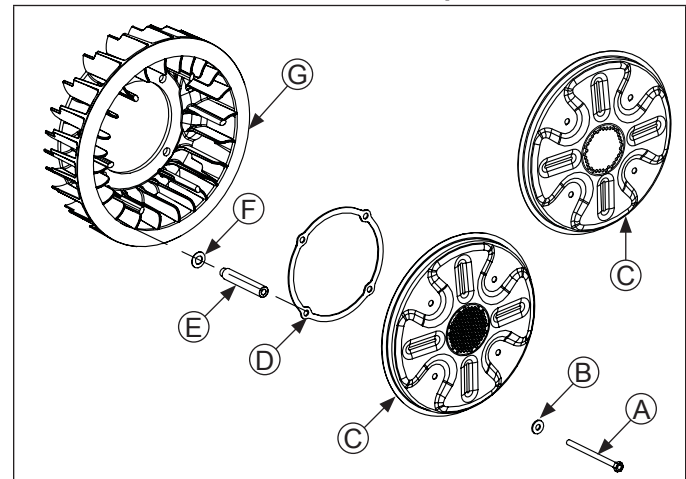

A	Screw Debris	B	Washer
C	Screen	D	Support Ring
E	Spacer	F	Spring Washer
G	Fan		

NOTE: Use this disassembly sequence if fan and debris screen are being repaired/replaced individually.

NOTE: Inspect fan/screen assembly for cracks, nicks, or damage of any kind. Replace fan and/or screen if any damage is found.

1. Remove screws and washers securing screen.
2. Remove screen, support ring, and spacers, paying attention to curvature of spring washers between spacers and fan.

Remove Debris Screen and Fan Option #2

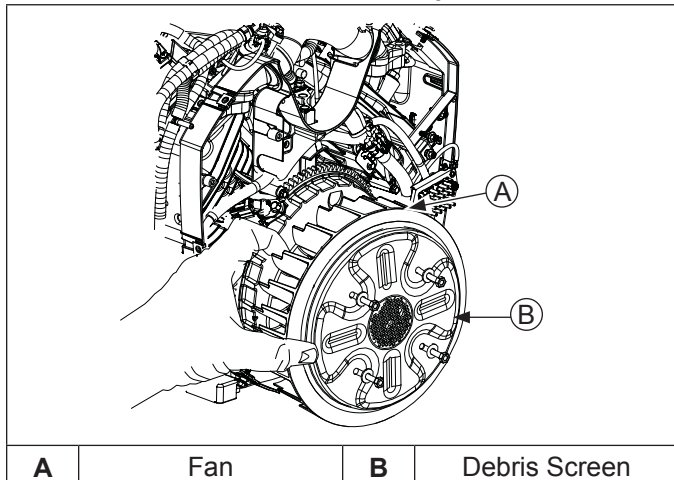

NOTE: Use this disassembly sequence if fan and debris screen are not being repaired/replaced individually.

NOTE: Inspect fan/screen assembly for cracks, nicks, or damage of any kind. Replace fan and/or screen if any damage is found.

Loosen screws while holding screen against flywheel fan.

Continue to hold screen and fan together. Carefully separate fan/screen assembly from face of flywheel. It is important to retain fan and screen together as a complete assembly. This will allow screen spacers and spring washers to stay in place.

Once assembly is removed from flywheel, carefully set aside assembly with fan on bottom and screen on top.

Remove Flywheel

Flywheel, Backing Shroud, and Baffle Components

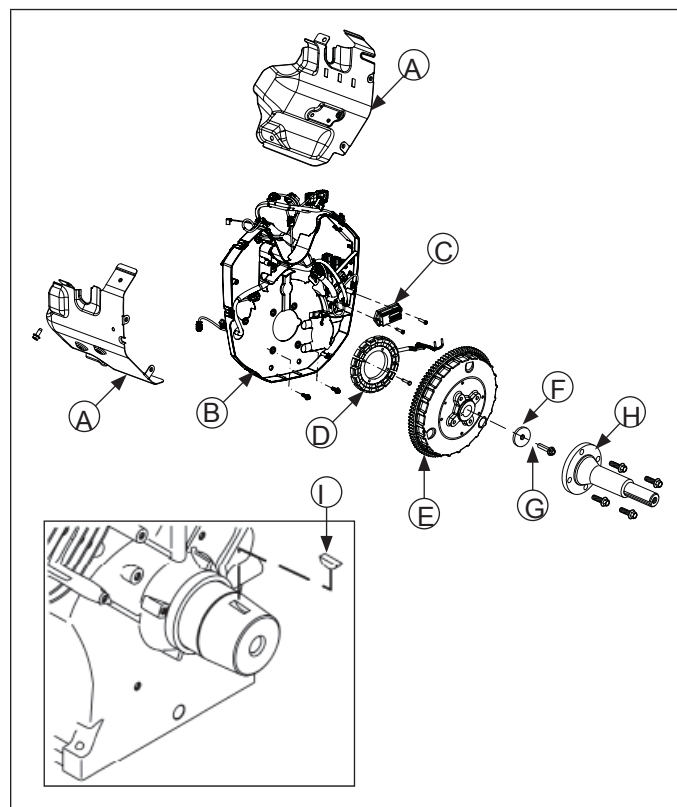

NOTE: Always use a flywheel strap wrench or holding tool to hold flywheel when loosening or tightening flywheel screw. Do not use any type of bar or wedge to hold flywheel. Use of such tools could cause flywheel to become cracked or damaged.

NOTE: Always use a flywheel puller to remove flywheel from crankshaft. Do not strike crankshaft or flywheel, as these parts could become cracked or damaged.

1. If equipped, loosen screws securing front drive shaft to flywheel and carefully remove shaft.
2. Use a flywheel strap wrench or holding tool to hold flywheel and loosen screw securing flywheel to crankshaft.
3. Remove screw and washer.
4. Use a puller to remove flywheel from crankshaft.
5. Remove woodruff key from crankshaft.

Disassembly/Inspection and Service

Inspection

Inspect flywheel for cracks and flywheel keyway for damage. Replace flywheel if it is cracked. Replace flywheel and crankshaft if keyway is damaged. Replace flywheel key if sheared or damaged.

Inspect ring gear for cracks or damage. Rehlko does not provide ring gear as a serviceable part. Replace flywheel if ring gear is damaged.

Remove Stator and Rectifier-Regulator

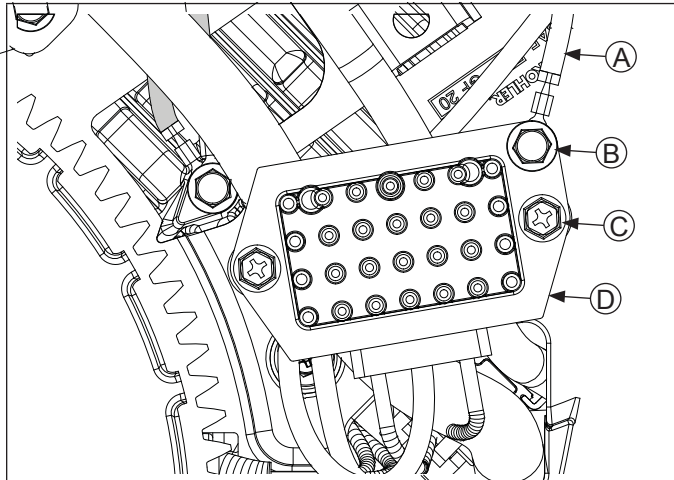

A	Ground Lead	B	Ground Lead Screw
C	Screw	D	Rectifier-Regulator

1. Disconnect plug from rectifier-regulator. Only disconnect B+ (center) lead if replacing stator or wiring harness. If it must be removed from plug, use a small flat tool to bend locking tang. Then remove lead.
2. Note location of ground lead. Remove ground lead screw and ground lead.
3. Remove mounting screws securing rectifier-regulator assembly.
4. Remove screws securing stator to crankcase. If stator is not being replaced, keep stator leads in their position in backing shroud. If replacing stator, note stator wire routing, cut wire ties, then carefully separate stator wires from backing shroud.

Remove Fuses

Disconnect fuses from holders on barrel baffle.

Remove Barrel Baffles

NOTE: Do not remove ignition coils from baffles unless coils are being replaced.

1. Disconnect wiring harness lead from each ignition coil.
2. Remove screws securing barrel baffle to backing shroud; 2 on each side.
3. Remove 2 screws securing baffle to cylinder head and crankcase.
4. Carefully squeeze clip and remove ignition coil from baffle.

Remove Backing Shroud and Wiring Harness

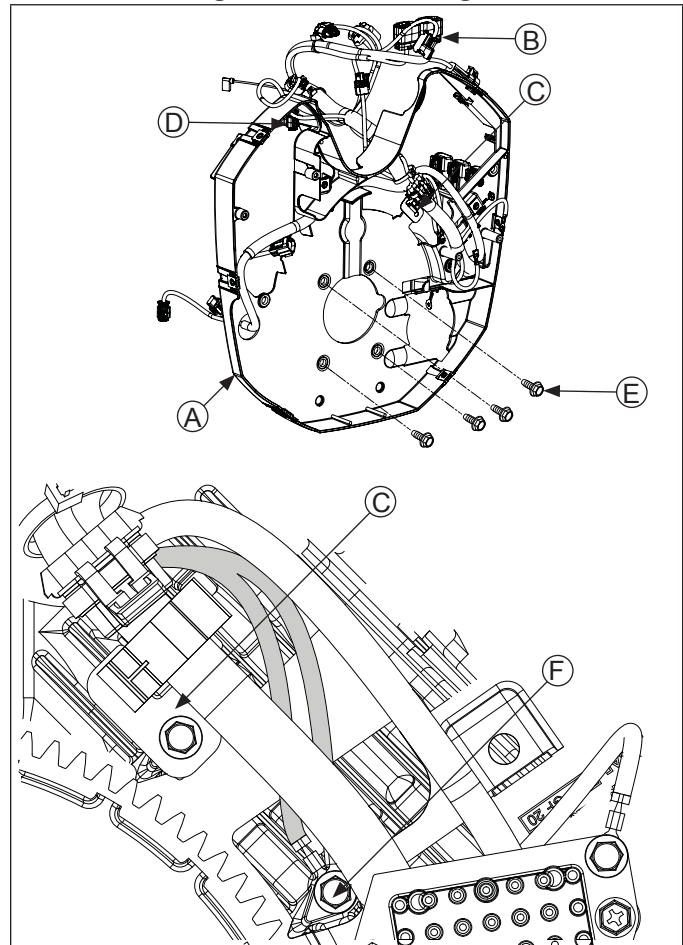

A	Ground Lead	A	Wiring Harness
C	Wire Harness Clamp	D	Engine (oil) Temperature Sensor Connector
E	Backing Shroud	F	Ground Wire Screws

NOTE: Pay attention to how wires are routed prior to removal.

Disconnect engine (oil) temperature sensor connector from top of engine.

Remove screw securing ground wires and remove screw securing wire harness clamp to crankcase.

Remove screws securing backing shroud to crankcase. Remove backing shroud and wiring harness as a complete assembly.

Cylinder Head Components

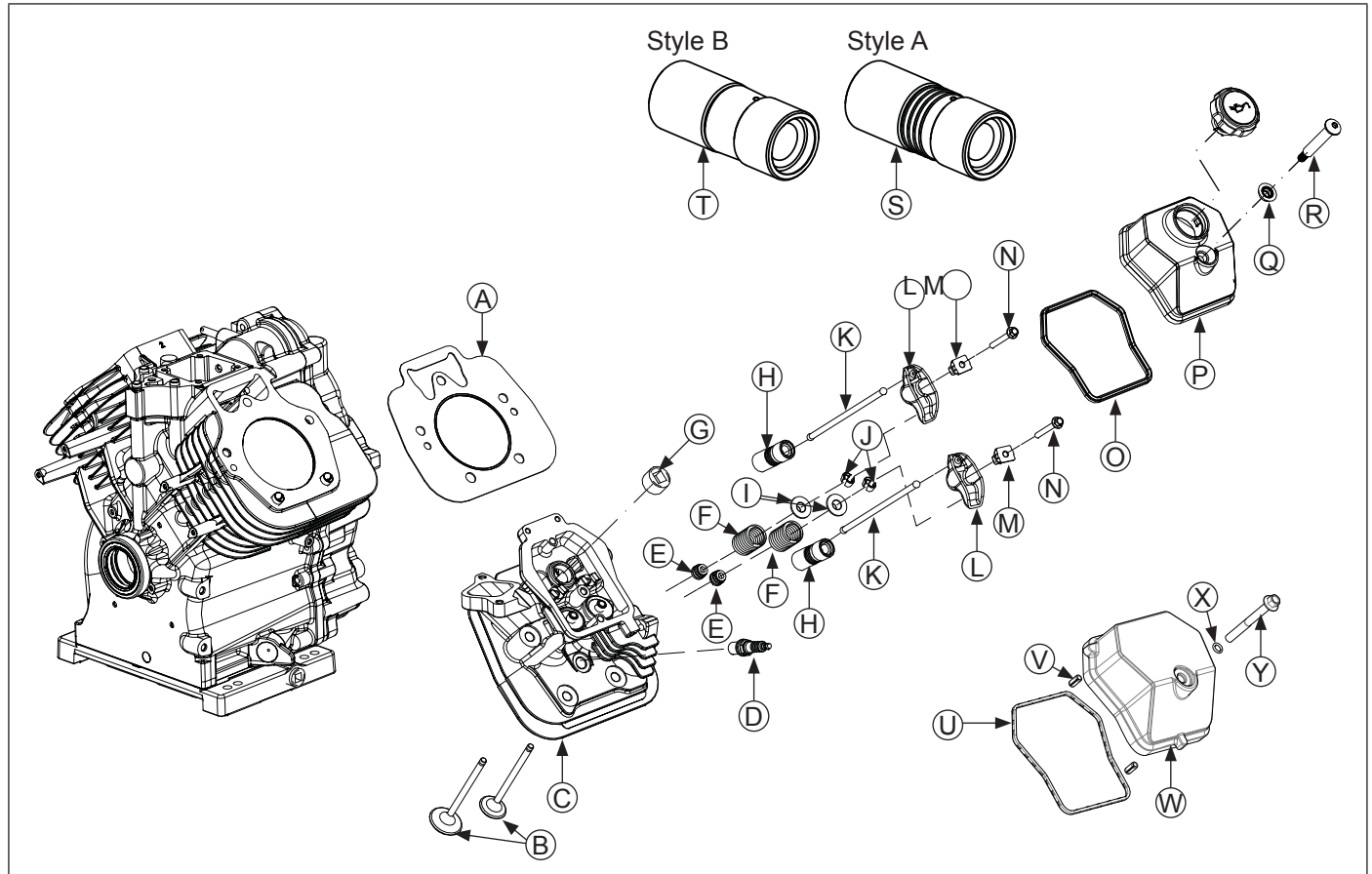



A	Gasket	B	Valve	C	Cylinder Head	D	Spark Plug
E	Valve Stem Seal	F	Valve Spring	G	Pipe Plug	H	Hydraulic Lifter
I	Valve Spring Cap	J	Valve Spring Keeper	K	Push Rod	L	Rocker Arm
M	Rocker Arm Pivots	N	Rocker Arm Screw	O	Valve Cover Seal (Plastic Valve Cover)	P	Valve Cover (Plastic)
Q	Grommet (Plastic Valve Cover)	R	Screw (Plastic Valve Cover)	S	Hydraulic Lifter Style A (Ribbed)	T	Hydraulic Lifter Style B (Smooth)
U	Valve Cover Seal (Aluminum Valve Cover)	V	Roll Pin (Aluminum Valve Cover)	W	Valve Cover (Aluminum)	X	O-Ring (Aluminum Valve Cover)
Y	Screw (Aluminum Valve Cover)						

Disassembly/Inspection and Service

Remove Spark Plugs

Remove spark plug from each cylinder head.

Remove Valve Covers and Fuel Pump

	WARNING
	Explosive Fuel can cause fires and severe burns.
	Do not fill fuel tank while engine is hot or running.
Gasoline is extremely flammable and its vapors can explode if ignited. Store gasoline only in approved containers, in well ventilated, unoccupied buildings, away from sparks or flames. Spilled fuel could ignite if it comes in contact with hot parts or sparks from ignition. Never use gasoline as a cleaning agent.	

Valve Covers

Plastic Valve Covers

1. Remove screw and grommet securing each valve cover.
2. Remove valve cover and seal from each cylinder head. Note locations of individual valve covers if they are different.

Aluminum Valve Covers

NOTE: A new valve cover seal must be installed whenever an aluminum valve cover is removed from cylinder head.

1. Remove screw and O-ring securing each valve cover.
2. Remove valve cover and seal from each cylinder head. Note locations of individual valve covers if they are different. Remove seal from valve cover; discard seal.

Remove Cylinder Heads and Hydraulic Lifters

NOTE: Exhaust lifters are located on output shaft side of engine while intake lifters are located on fan side of engine. Cylinder head number is embossed on outside of each cylinder head.

1. Remove pipe plug from cylinder head to access screw in upper center location.
2. Remove screws securing each cylinder head. Note locations of washers and spacer.
3. Mark position of push rods as either intake or exhaust and cylinder 1 or 2. Push rods should always be reinstalled in same positions.
4. Carefully remove push rods, cylinder head and head gasket.
5. Repeat procedure for other cylinder head.
6. Remove lifters from lifter bores. Use a hydraulic lifter tool. Do not use a magnet to remove lifters. Mark lifters by location, as either intake or exhaust and cylinder 1 or 2. Hydraulic lifters should always be reinstalled in same position.

Inspection

Check base surface of hydraulic lifters for wear or damage. If lifters need to be replaced, apply a liberal coating of Rehlko lubricant to base of each new lifter before it is installed.

Bleeding Lifters

To prevent a possible bent push rod or broken rocker arm, it is important to bleed any excess oil out of lifters before they are installed.

1. Cut a 50-75 mm (2-3 in.) piece from end of an old push rod and chuck it in a drill press.
2. Lay a rag or shop towel on table of drill press and place lifter, open end up, on towel.
3. Lower chucked push rod until it contacts plunger in lifter. Slowly pump plunger 2 or 3 times to force oil out of feed hole in side of lifter.

Disassemble Cylinder Heads

NOTE: These engines use valve stem seals on intake and exhaust valves. Use a new seal whenever valves are removed, or if seal is deteriorated in any way. Never reuse an old seal.

1. Remove screws, rocker arm pivots, and rocker arms from cylinder head.
2. Compress valve springs using a valve spring compressor.
3. Once valve spring is compressed, remove following items:
 - Valve spring keepers.
 - Valve spring caps.
 - Valve springs.
 - Intake and exhaust valves (mark position).
 - Valve stem seals.
4. Repeat above procedure for other cylinder head. Do not interchange parts from one cylinder head to another.

Inspection and Service Valve Details

Dimension		Intake	Exhaust
A	Seat Angle	89°	89°
B	Seat Taper	30°	30°
C	Guide Depth	8.5 mm (0.334 in.) 7.038/7.058 mm	8.5 mm (0.334 in.) 7.038/7.058 mm
D	Guide I.D.	(0.2771/0.2779 in.) 38.625/38.685 mm	(0.2771/0.2779 in.) 31.625/31.825 mm
E	Valve Head Diameter	(1.5206/1.5230 in.)	(1.2450/1.2549 in.)
F	Valve Face Angle	45°	45°
G	Valve Margin (Min.)	1.0 mm (0.0393 in.) 6.982/7.000 mm	1.0 mm (0.0393 in.) 6.970/6.988 mm
H	Valve Stem Diameter	(0.2749/0.2756 in.)	(0.2744/0.2751 in.)

After cleaning, check flatness of cylinder head and corresponding top surface of crankcase using a surface plate or precision straight edge and feeler gauge. Maximum allowable out of flatness is 0.076 mm (0.003 in.).

Carefully inspect valve mechanism parts. Inspect valve springs and related hardware for excessive wear or distortion. Check valves and valve seat area or inserts for evidence of deep pitting, cracks, or distortion. Check clearance of valve stems in guides.

Hard starting or loss of power accompanied by high fuel consumption may be symptoms of faulty valves. Although these symptoms could also be attributed to worn rings, remove and check valves first. After removal, clean valve heads, faces, and stems with a power wire brush.

Then, carefully inspect each valve for defects such as a warped head, excessive corrosion, or a worn stem end. Replace valves found to be in bad condition.

Valve Guides

If a valve guide is worn beyond specifications, it will not guide valve in a straight line. This may result in burnt valve faces or seats, loss of compression, and excessive oil consumption.

To check valve guide-to-valve stem clearance, thoroughly clean valve guide and, using a split-ball gauge, measure inside diameter of guide. Then, using an outside micrometer, measure diameter of valve stem at several points on stem where it moves in valve guide. Use largest stem diameter to calculate clearance by subtracting stem diameter from guide diameter. If intake clearance exceeds 0.038/0.076 mm (0.0015/0.0030 in.) or exhaust clearance exceeds 0.050/0.088 mm (0.0020/0.0035 in.), determine if valve stem or guide is responsible for excessive clearance.

Maximum (I.D.) wear on intake valve guide is 7.135 mm (0.2809 in.) and 7.159 mm (0.2819 in.) for exhaust guide. Guides are not removable but can be reamed 0.25 mm (0.010 in.) oversize. Valves with 0.25 mm oversize stems must then be used.

If guides are within limits but valve stems are worn beyond limits, install new valves.

Valve Seat Inserts

Hardened steel alloy intake and exhaust valve seat inserts are press fitted into cylinder head. Inserts are not replaceable but can be reconditioned if not too badly pitted or distorted. If cracked or badly warped, cylinder head should be replaced.

Disassembly/Inspection and Service

Recondition valve seat inserts following instructions provided with valve seat cutter being used. Final cut should be made with an 89° cutter as specified for valve seat angle. Cutting proper 45° valve face angle as specified, and proper valve seat angle (44.5°, half of full 89° angle), will achieve desired 0.5° (1.0° full cut) interference angle where maximum pressure occurs on outside diameters of valve face and seat.

Lapping Valves

Reground or new valves must be lapped in, to provide proper fit. Use a hand valve grinder with a suction cup for final lapping. Lightly coat valve face with a fine grade of grinding compound, then rotate valve on its seat with grinder. Continue grinding until a smooth surface is obtained on seat and on valve face. Thoroughly clean cylinder head in soap and hot water to remove all traces of grinding compound. After drying cylinder head, apply a light coating of SAE 10 oil to prevent rusting.

Valve Stem Seals

These engines use valve stem seals on intake and exhaust valves. Always use new seals when valves are removed from cylinder head. Seals should also be replaced if deteriorated or damaged in any way. Never reuse an old seal.

Breather/Closure Plate/Oil Reservoir Components

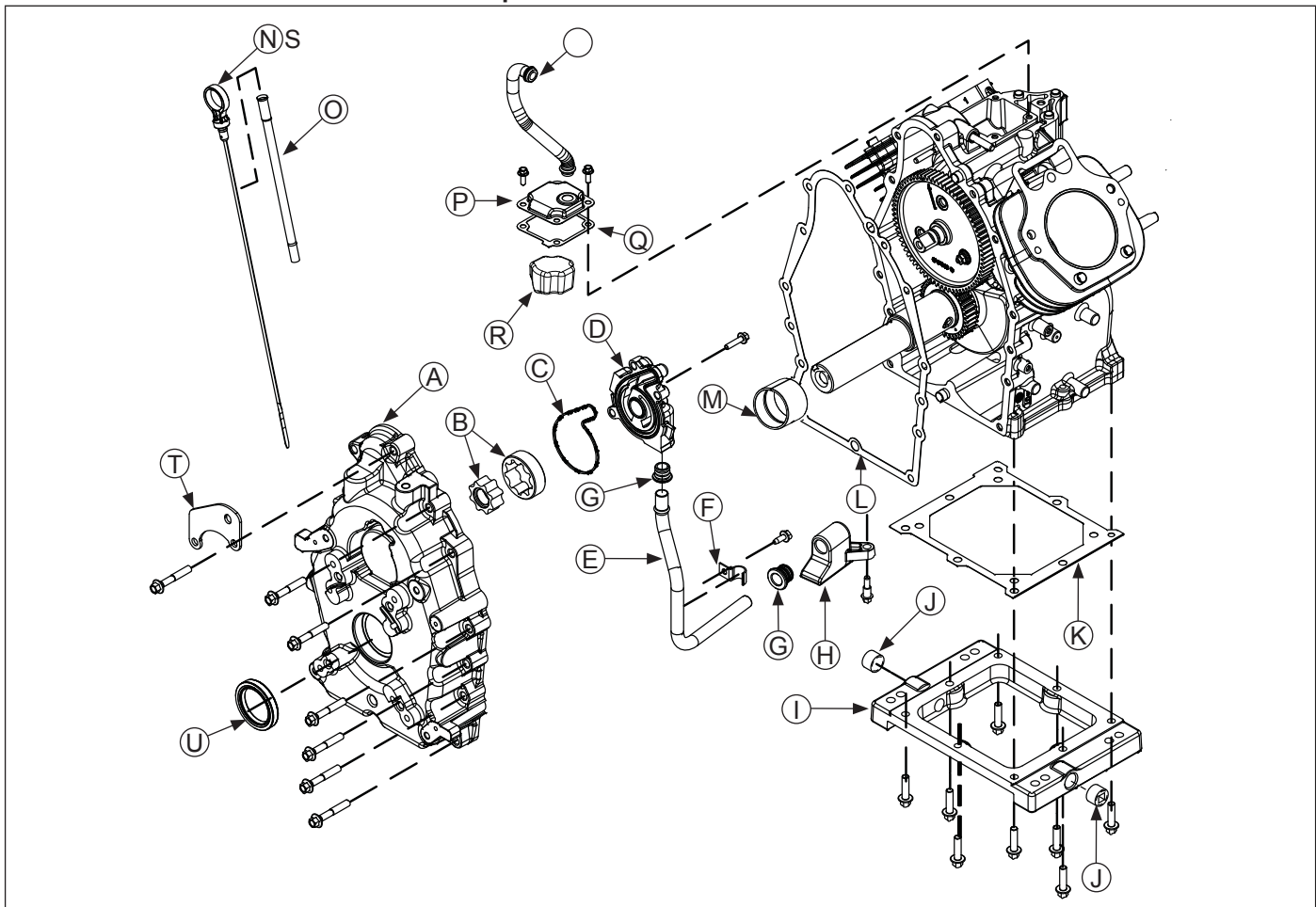

A	Closure Plate	B	Gerotor Gears	C	Oil Pump O-ring	D	Oil Pump Housing
E	Pickup Tube	F	Clamp Drain	G	Inlet Seal	H	Pickup Screen
I	Oil Reservoir	J	Plug	K	Gasket	L	Closure Plate Gasket
M	Crankshaft Non-Thrust Bearing (PTO)	N	Dipstick	O	Dipstick Tube	P	Breather Assembly
Q	Breather Gasket	R	Filter	S	Breather Hose	T	Lifting Strap
U	Oil Seal						

Remove Breather Assembly

1. Remove fasteners securing breather assembly and gasket to crankcase.
2. Carefully break gasket seal and remove all parts. Do not pry on sealing surfaces as it could cause damage resulting in leaks. Note assembly and orientation of parts.

Remove Oil Reservoir and Pickup Screen

1. Remove screws securing oil reservoir and gasket to engine.
2. Remove mounting screw and carefully work pickup screen off end of pickup tube.

Remove Closure Plate Assembly

1. Remove screws securing closure plate to crankcase.
2. Locate protruding tabs on closure plate. Carefully tap to break gasket seal. Do not pry on sealing surfaces as this could cause leaks. Separate closure plate from crankcase. Remove old gasket.

Inspection

Inspect oil seal in closure plate and replace it if worn or damaged.

Inspect crankshaft bearing surface for wear or damage. Replace bearing or closure plate assembly if required.

Oil Pump Assembly

Disassembly 1.

1. Remove screws securing oil pump housing and pickup tube clamp.
2. Remove oil pump housing and pickup tube from closure plate.
3. Remove oil pump gerotor gears from closure plate recess.
4. Remove oil pickup tube and inlet seal from oil pump body.
5. Relief valve is a one-piece style, staked to oil pump housing; removal should not be attempted, nor is internal servicing possible. If a problem with relief valve is encountered, oil pump should be replaced.

Inspection

Inspect oil pump housing, gerotor gears, and closure plate recess for nicks, burrs, wear, or any visible damage. Inspect inlet seal of pickup tube. If any parts are worn or damaged, replace seal, oil pump or closure plate as required.

Reassembly Torque Sequence

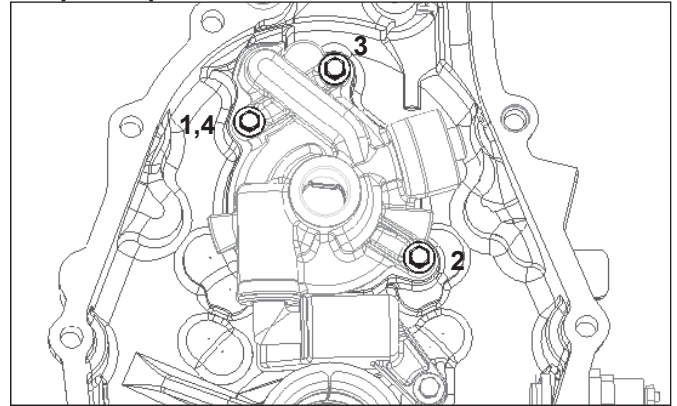

1. Make sure recess in closure plate for oil pump gerotor gears is clean.
2. Lubricate oil pump gerotor gears with grease (Lubriplate® 100 or equivalent), and install into recess.
3. Lightly lubricate with oil and install inlet seal into oil pump housing until it is fully seated.
4. Install O-ring in groove of oil pump housing. Use a small quantity of grease to hold it in place.
5. Lightly lubricate I.D. of inlet seal with oil and carefully insert ferruled end of pickup tube through grommet, into oil pump housing. Position pickup tube so out-board end faces up.
6. Install oil pump housing with pickup tube, over oil pump boss and gears. Align all 3 screw locations.
7. Install clamp for pickup tube and finger tighten screw. Check alignment of parts and torque oil pump housing screws to 9.9 N·m (88 in. lb.) using sequence below:
 - a. Install fastener into location 1 and lightly tighten to position pump.
 - b. Install fastener into location 2 and fully torque to recommended value.
 - c. Install fastener into location 3 and fully torque to recommended value.
 - d. Finish torquing fastener in location 1 to recommended value.
8. Torque clamp (pickup tube) mounting screw to 11.3 N·m (100 in. lb.) into new hole or 7.7 N·m (68 in. lb.) into used hole.

Install Closure Plate Crankshaft Bearing (PTO) and Oil Seal

If bearing was removed in servicing, install a new bearing using an arbor press and driver.

1. Make sure closure plate bore for bearing is clean, dry and free of nicks or burrs.
2. Press closure plate side main bearing in place with notch oriented in 12 o'clock position using an arbor press and driver. Make sure bearing is fully seated against flange.

Disassembly/Inspection and Service

Oil Seal Details

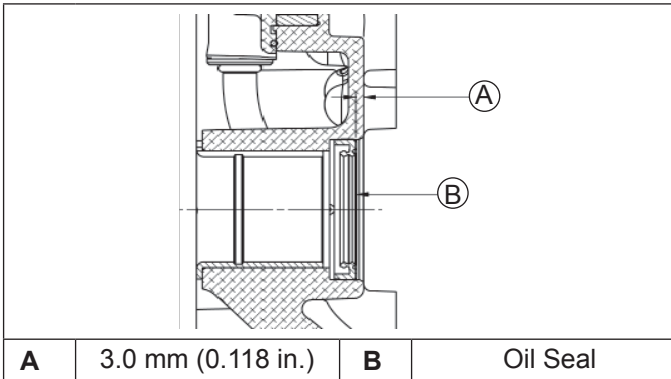

1. Check to make sure there are no nicks or burrs in crankshaft seal bore of closure plate.
2. Apply a light coat of P80 Emulsion Lubricant (refer to Tools and Aids) to outside diameter of oil seal.
3. Install oil seal into closure plate using a seal driver. Make sure oil seal is installed straight and true in bore to depth shown.
4. Apply a light coat of clean engine oil to inner surface of bearing and oil seal.

Crankcase Components

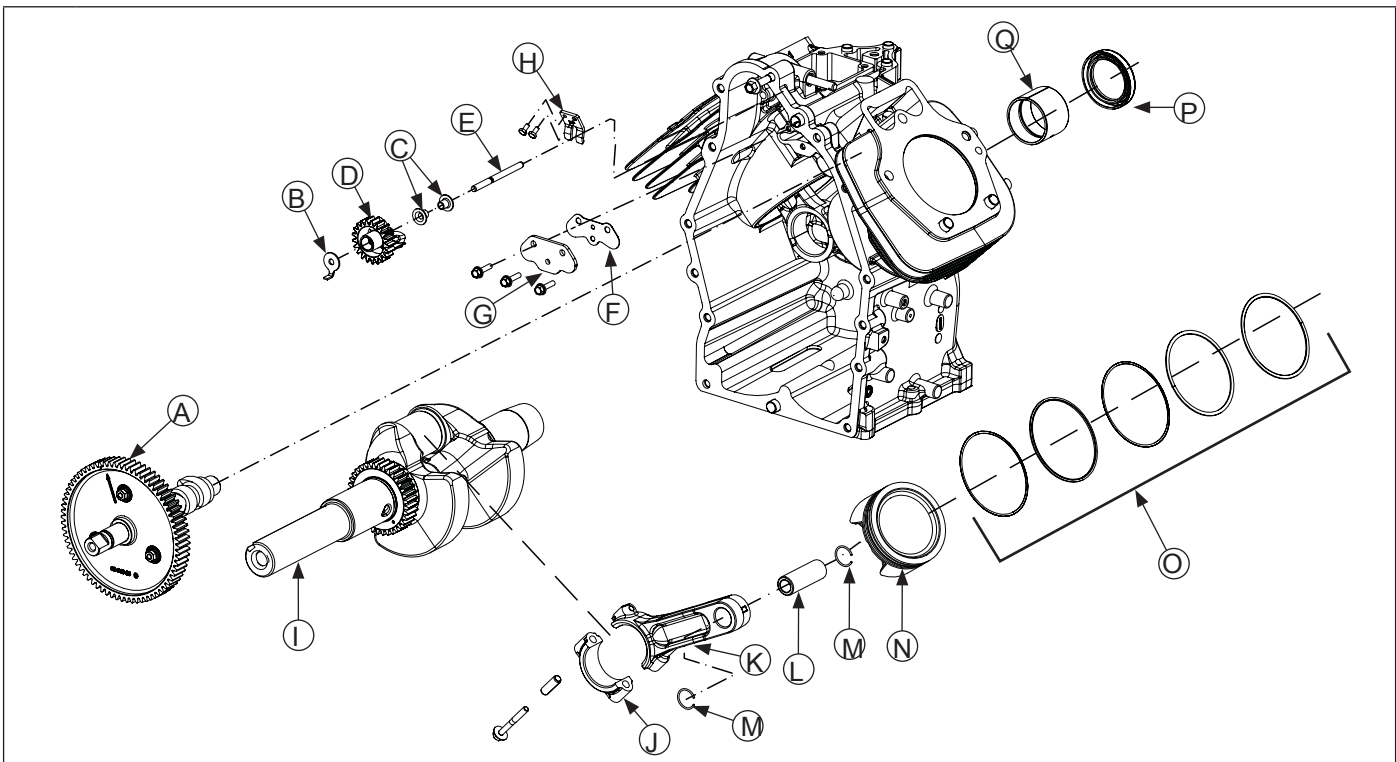

A	Camshaft	B	Locking Tab	C	Regulating Pin	D	Governor Gear
E	Governor Gear Shaft	F	Lift Feed Cover Gasket	G	Lifter Feed Cover	H	Governor Yoke
I	Crankshaft	J	Connecting Rod End Cap	K	Connecting Rod	L	Piston Pin
M	Piston Pin Retainer	N	Piston	N	Piston Ring Set	P	Oil Seal
Q	Crankshaft Non-Thrust Bearing						

Remove Camshaft

Remove camshaft and shim (if used).

Inspection

Check lobes of camshaft for wear or damage. Inspect cam gear for badly worn, chipped, or missing teeth. Replacement of camshaft will be necessary if any of these conditions exist.

Remove Connecting Rods with Pistons and Rings

NOTE: If a carbon ridge is present at top of either cylinder bore, use a ridge reamer tool to remove ridge before attempting to remove piston.

NOTE: Cylinders are numbered on crankcase. Use numbers to mark each end cap, connecting rod and piston for reassembly. Do not mix end caps and connecting rods.

1. Remove screws securing closest connecting rod end cap. Remove end cap.
2. Carefully remove connecting rod and piston assembly from cylinder bore.
3. Repeat above procedures for other connecting rod and piston assembly.

Connecting Rods

Offset, stepped-cap connecting rods are used in these engines.

Inspection and Service

Check bearing area (big end) for excessive wear, score marks, running and side clearances. Replace rod and cap if scored or excessively worn.

Service replacement connecting rods are available in STD crankpin size and 0.25 mm (0.010 in.) undersize. Always refer to appropriate parts information to ensure that correct replacements are used.

Piston and Rings

Inspection

Piston and Rings Components and Details

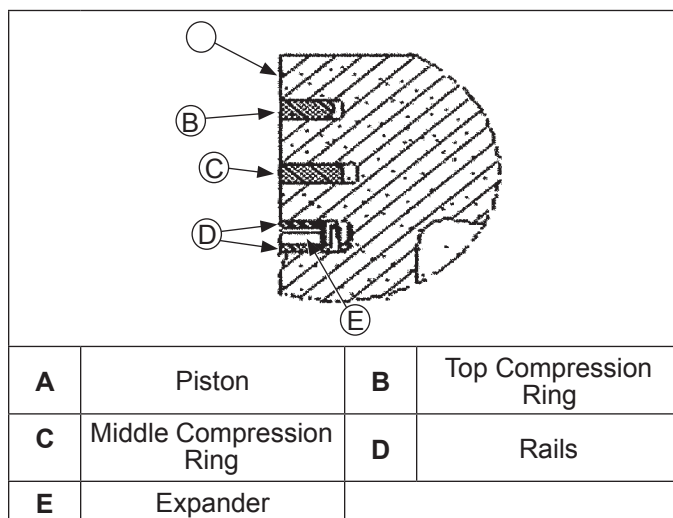

Scuffing and scoring of pistons and cylinder walls occurs when internal engine temperatures approach welding point of piston. Temperatures high enough to do this are created by friction, which is usually attributed to improper lubrication and/or overheating of engine.

Normally, very little wear takes place in piston boss/piston pin area. If original piston and connecting rod can be reused after new rings are installed, original pin can also be reused but new piston pin retainers are required. Piston pin is included as part of piston assembly – if pin boss in piston or pin are worn or damaged, a new piston assembly is required.

Ring failure is usually indicated by excessive oil consumption and blue exhaust smoke. When rings fail, oil is allowed to enter combustion chamber where it is burned along with fuel. High oil consumption can also occur when piston ring end gap is incorrect because ring cannot properly conform to cylinder wall under this condition. Oil control is also lost when ring gaps are not staggered during installation.

When cylinder temperatures get too high, lacquer and varnish collect on pistons causing rings to stick, which results in rapid wear. A worn ring usually takes on a shiny or bright appearance.

Scratches on rings and pistons are caused by abrasive material such as carbon, dirt, or pieces of hard metal.

Detonation damage occurs when a portion of fuel charge ignites spontaneously from heat and pressure shortly after ignition. This creates 2 flame fronts which meet and explode to create extreme hammering pressures on a specific area of piston. Detonation generally occurs from using low octane fuels.

Preignition or ignition of fuel charge before timed spark can cause damage similar to detonation. Preignition damage is often more severe than detonation damage. Preignition is caused by a hot spot in combustion chamber from sources such as glowing carbon deposits, blocked cooling fins, an improperly seated valve, or wrong spark plug(s).

Replacement pistons are available in STD bore size, and in 0.25 mm (0.010 in.), and 0.50 mm (0.020 in.) oversize. Replacement pistons include new piston ring sets and new piston pins.

Replacement ring sets are also available separately for STD, 0.25 mm (0.010 in.), and 0.50 mm (0.020 in.) oversize pistons. Always use new piston rings when installing pistons. Never reuse old rings.

Some important points to remember when servicing piston rings:

1. Cylinder bore must be de-glazed before service ring sets are used.
2. If cylinder bore does not need re-boring and if old piston is within wear limits and free of score or scuff marks, old piston may be reused.
3. Remove old rings and clean up grooves. Never reuse old rings.

Disassembly/Inspection and Service

- Before installing new rings on piston, place top 2 rings, each in turn, in its running area in cylinder bore and check end gap. Top compression ring end gap clearance is 0.125/0.304 mm (0.0049/0.0120 in.) for a new bore, or 0.515 mm (0.0203 in.) for a used bore. Middle compression ring end cap is 0.900/1.179 mm (0.0354/0.0464 in.) for a new bore, or 1.432 mm (0.0564 in.) for a used bore.
- After installing new compression (top and middle) rings on piston, make sure top compression ring-to-groove side clearance and is 0.030/0.070 mm (0.0010/0.0026 in.) and middle compression ring-to-groove side clearance 0.030/0.070 mm (0.0010/0.0026 in.). If side clearance is greater than specified, a new piston must be used.

Install New Piston Rings

Piston Ring Orientation

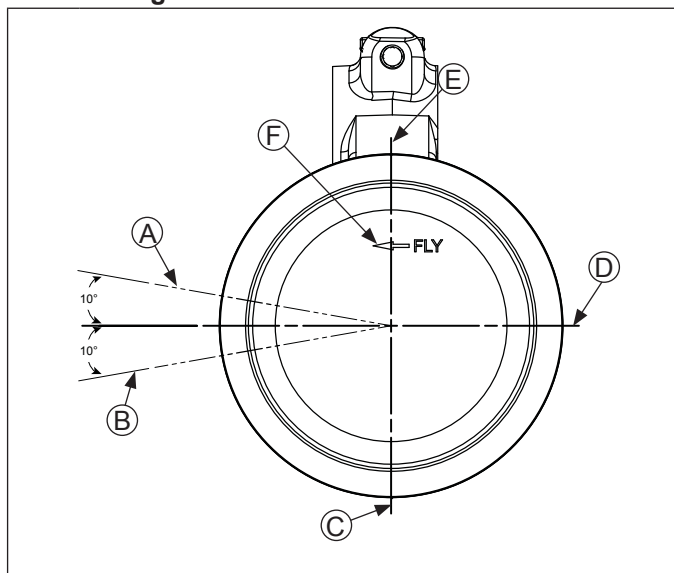

A	Top Oil Ring Rail Gap	B	Bottom Oil Ring Rail Gap
C	Intermediate Ring Gap	D	Oil Ring Expander Gap
E	Top Ring Gap	F	FLY Stamp

NOTE: Rings must be installed correctly. Ring installation instructions are usually included with new ring sets. Follow instructions carefully. Use a piston ring expander to install rings. Install bottom (oil control) ring first and top compression ring last.

To install new piston rings, proceed as follows:

- Oil control ring (bottom groove): Install expander and then rails. Make sure ends of expander are not overlapped.
- Middle compression ring (center groove): Install center ring using a piston ring installation tool. Make sure identification mark is up or colored dye stripe (if contained), is to left of end gap.
- Top compression ring (top groove): Install top ring using a piston ring expander. Make sure identification mark is up or colored dye stripe (if contained), is to left of end gap.

Remove Crankshaft

NOTE: If crankpin is reground, visually check to ensure that fillet blends smoothly with crankpin surface.

Carefully pull crankshaft from crankcase. Note thrust washers and shims if used.

Inspection and Service Crankshaft Components and Details

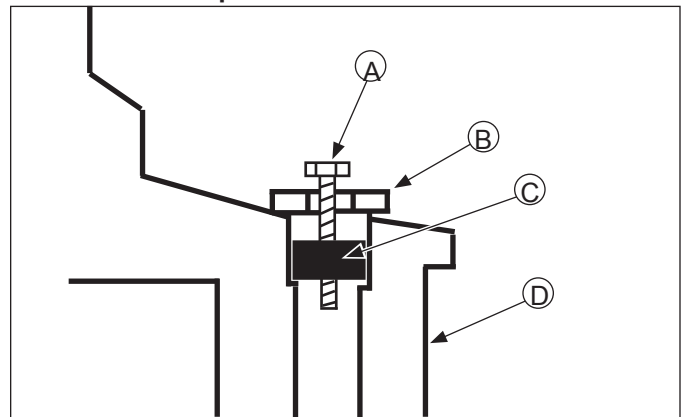

A	Self-Tapping Screw	B	Flat Washer
C	Plug	D	Crankshaft

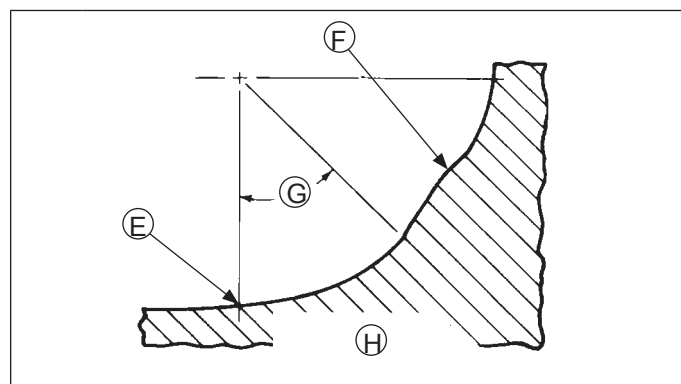

E	Fillet Must Blend Smoothly with Bearing Journal Surface
F	High Point from Fillet Intersections
G	45° Minimum
H	This Fillet Area Must Be Completely Smooth

Inspect gear teeth of crankshaft. If teeth are badly worn, chipped, or some are missing, replacement of crankshaft will be necessary.

Inspect crankshaft bearing surfaces for scoring, grooving, etc. Replaceable bearing is used in crankshaft bore of closure plate and/or crankcase. Do not replace bearing unless they show signs of damage or are out of running clearance 0.040/0.167 mm (0.0015/0.0065 in.). If crankshaft turns easily, without noise, and there is no evidence of scoring, grooving, etc., on races or bearing surfaces, bearing can be reused.

Disassembly/Inspection and Service

Inspect crankshaft keyways. If they are worn or chipped, replacement of crankshaft will be necessary.

Inspect crankpin for score marks or metallic pickup. Slight score marks can be cleaned with crocus cloth soaked in oil. If wear limits, as stated in Clearance Specifications, are exceeded, it will be necessary to replace crankshaft or regrind crankpin to 0.25 mm (0.010 in.) undersize. If reground, a 0.25 mm (0.010 in.) undersize connecting rod (big end) must then be used to achieve proper running clearance. Measure crankpin for size, taper, and out-of-round.

Clearance Specifications-Connecting Rod Journal

O.D. - New	43.982/44.000 mm (1.731/1.732 in.)
O.D. - Max. Wear Limit	43.97 mm (1.731 in.)
Max. Taper	0.018 mm (0.0007 in.)
Max. Out-of-Round	0.025 mm (0.0010 in.)
Width	53.00/53.09 mm (2.0866/2.0901 in.)

Connecting rod journal can be ground 1 size under. When grinding a crankshaft, grinding stone deposits can get caught in oil passages, which could cause severe engine damage. Removing crankpin plug when crankshaft is ground provides easy access for removing any grinding deposits that may collect in oil passages.

Use following procedure to remove and replace plug.

Remove Crankshaft Plug

1. Drill a 3/16 in. hole through plug in crankshaft.
2. Thread a 3/4 in. or 1 in. long self-tapping screw with a flat washer into drilled hole. Flat washer must be large enough to seat against shoulder of plug bore.
3. Tighten self-tapping screw until it draws plug out of crankshaft.

Install New Crankshaft Plug

Use 1 single cylinder camshaft pin, as a driver and tap plug into plug bore until it seats at bottom of bore. Make sure plug is tapped in evenly to prevent leakage.

Remove Governor Gear Assembly

Governor gear is held onto shaft by small molded tabs in gear. When gear is removed from shaft, these tabs are destroyed and gear must be replaced. Therefore, remove gear only if absolutely necessary. If governor cross shaft, yoke, or gear condition does not require removal, governor gear may be left in place. If removal is necessary, perform as follows:

1. Remove locking tab thrust washer and note orientation.
2. Using a screwdriver, carefully pry upward to unseat governor gear assembly from governor gear shaft. Remove regulating pin and governor gear assembly.
3. Inspect governor gear shaft for wear or damage. Remove shaft only if replacement is needed.

Inspection

Governor gear is located within crankcase. Inspect governor gear teeth. Replace gear if it is worn, chipped, or if any teeth are missing. Inspect governor weights. They should move freely in governor gear.

Remove Governor Yoke, Cross Shaft, and Seal

1. Remove mounting screws securing yoke to governor cross shaft.
2. Pull governor cross shaft out of crankcase and remove seal.

Remove Lifter Feed Chamber Cover and Gasket

Remove screws securing lifter feed, cover, and gasket. Carefully separate parts from crankcase.

Remove Flywheel End Oil Seal

Remove oil seal from crankcase using a seal puller.

Remove Crankshaft Bearing (flywheel)

NOTE: Bearing should only be removed if replacement is required due to wear. If removal is performed, use a press and support casting surface around bearing flange. Do not press against or support by gasket/outer perimeter surface.

Crankcase

Inspection and Service

Check all gasket surfaces to make sure they are free of gasket fragments. Gasket surfaces must also be free of deep scratches or nicks.

Inspect crankshaft bearing (if equipped) for wear or damage. Replace bearing or crankcase using a miniblock or short block as required.

Check cylinder bore for scoring. In severe cases, unburned fuel can cause scuffing and scoring of cylinder wall. It washes necessary lubricating oils off piston and cylinder wall. As raw fuel seeps down cylinder wall, piston rings make metal to metal contact with wall. Scoring of cylinder wall can also be caused by localized hot spots resulting from blocked cooling fins or from inadequate or contaminated lubrication.

If cylinder bore is badly scored, excessively worn, tapered, or out-of-round, resizing is necessary. Use an inside micrometer to determine amount of wear, then select nearest suitable oversize of either 0.25 mm (0.010 in.) or 0.50 mm (0.020 in.). Resizing to these oversizes will allow usage of available oversize piston and ring assemblies. Initially, resize using a boring bar, then use following procedures for honing cylinder.

Disassembly/Inspection and Service

Honing Detail

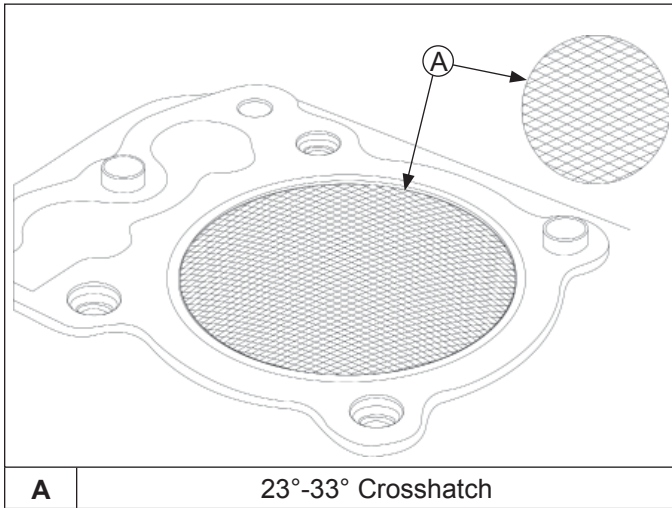

NOTE: Rehlko pistons are custom-machined to exacting tolerances. When oversizing a cylinder, it should be machined exactly 0.25 mm (0.010 in.) or 0.50 mm (0.020 in.) over new diameter. Corresponding oversize Rehlko replacement piston will then fit correctly.

While most commercially available cylinder hones can be used with either portable drills or drill presses, use of a low speed drill press is preferred as it facilitates more accurate alignment of bore in relation to crankshaft crossbore. Honing is best accomplished at a drill speed of about 250 RPM and 60 strokes per minute. After installing coarse stones in hone, proceed as follows:

1. Lower hone into bore and after centering, adjust so stones are in contact with cylinder wall. Use of a commercial cutting-cooling agent is recommended.
2. With lower edge of each stone positioned even with lowest edge of bore, start drill and honing process. Move hone up and down while resizing to prevent formation of cutting ridges. Check size frequently.
3. When bore is within 0.064 mm (0.0025 in.) of desired size, remove coarse stones and replace them with burnishing stones. Continue with burnishing stones until bore is within 0.013 mm (0.0005 in.) of desired size and then use finish stones (220-280 grit) and polish bore to its final size. A crosshatch should be observed if honing is done correctly. Crosshatch should intersect at approximately 23°-33° off horizontal. Too flat an angle could cause rings to skip and wear excessively, and too steep an angle will result in high oil consumption.
4. After resizing, check bore for roundness, taper, and size. Use an inside micrometer, telescoping gauge, or bore gauge to take measurements. These measurements should be taken at 3 locations in cylinder – at top, middle, and bottom. There are 2 measurements that should be taken (perpendicular to each other) at all 3 locations.

Clean Cylinder Bore After Honing

Proper cleaning of cylinder walls following boring and/or honing is very critical to a successful overhaul. Machining grit left in cylinder bore can destroy an engine in less than 1 hour of operation after a rebuild.

Final cleaning operation should always be a thorough scrubbing with a brush and hot, soapy water. Use a strong detergent that is capable of breaking down machining oil while maintaining a good level of suds. If suds break down during cleaning, discard dirty water and start again with more hot water and detergent. Following scrubbing, rinse cylinder with very hot, clear water, dry it completely, and apply a light coating of engine oil to prevent rusting.

Measuring Piston-to-Bore Clearance Piston Detail

Piston Details

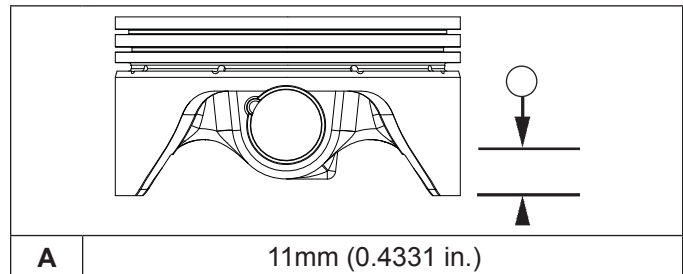

NOTE: Do not use a feeler gauge to measure piston-to-bore clearance; it will yield inaccurate measurements. Always use a micrometer

Before installing piston into cylinder bore, it is necessary that clearance be accurately checked. This step is often overlooked, and if clearances are not within specifications, engine failure will usually result.

Use following procedure to accurately measure piston-to-bore clearance:

1. Use a micrometer and measure diameter of piston above bottom of piston skirt and perpendicular to piston pin.
2. Use an inside micrometer, telescoping gauge, or bore gauge and measure cylinder bore. Take measurement approximately 63.5 mm (2.5 in.) below top of bore and perpendicular to piston pin.
3. Piston-to-bore clearance is difference between bore diameter and piston diameter (step 2 minus step 1).

Crankcase Components

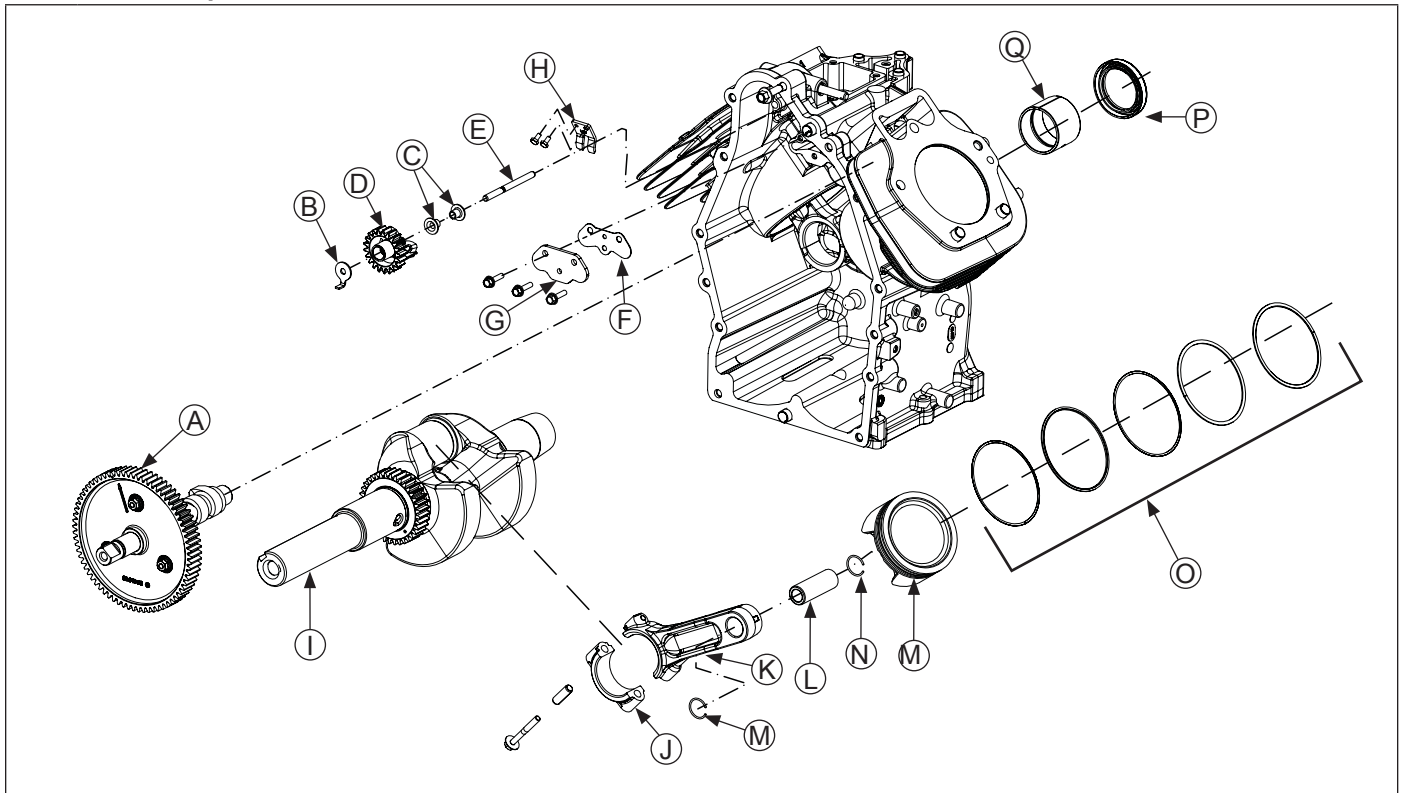

A	Camshaft	B	Locking Tab	C	Regulating Pin	D	Governor Gear
E	Governor Gear Shaft	F	Lifter Feed Cover Gasket	G	Lifter Feed Cover	H	Governor Yoke
I	Crankshaft	J	Connecting Rod End Cap	K	Connecting Rod	L	Piston Pin
M	Piston Pin Retainer	N	Piston	O	Piston Ring Set	P	Oil Seal
Q	Crankshaft Non-Thrust Bearing						

Reassembly

NOTE: Make sure engine is assembled using all specified torque values, torque sequences, and clearances. Failure to observe specifications could cause severe engine wear or damage. Always use new gaskets. Apply a small amount of oil to threads of critical fasteners before assembly, unless a sealant or Loctite® is specified or preapplied.

Make sure all traces of any cleaner are removed before engine is assembled and placed into operation. Even small amounts of these cleaners can quickly break down lubricating properties of engine oil.

Check closure plate, crankcase, cylinder heads, and valve covers to be certain all old gasket material has been removed. Use gasket remover, lacquer thinner, or paint remover to remove any remaining traces. Clean surfaces with isopropyl alcohol, acetone, lacquer thinner, or electrical contact cleaner.

Install Flywheel End Oil Seal

1. Make sure seal bore of crankcase is clean and free of any nicks or burrs.
2. Apply a light coat of P80 Emulsion Lubricant (refer to Tools and Aids) to outside diameter of oil seal.
3. Install oil seal into crankcase using a seal driver. Make sure oil seal is installed straight and true in bore and tool bottoms against crankcase.

Install Lifter Feed Chamber Gasket and Cover

1. Install lifter feed chamber gasket, followed by lifter feed cover over lifter feed chamber.
2. Install 3 screws. Make sure all parts are properly aligned. Torque screws to 7.7 N·m (68 in. lb.).

Install Crankshaft Bearing (flywheel)

If bearing was removed in servicing, install a new bearing using an arbor press and driver.

1. Make sure crankcase bore for bearing is clean, dry and free of nicks or burrs.
2. Press flywheel side main bearing in place with notch oriented in 12 o'clock position using an arbor press and driver. Make sure bearing is fully seated against flange and oil feed hole is open in crankcase.
3. Apply a light coat of clean engine oil to inner surface of bearing and oil seal.

Install Governor Shafts, Seal, and Governor Gear Governor Components and Details

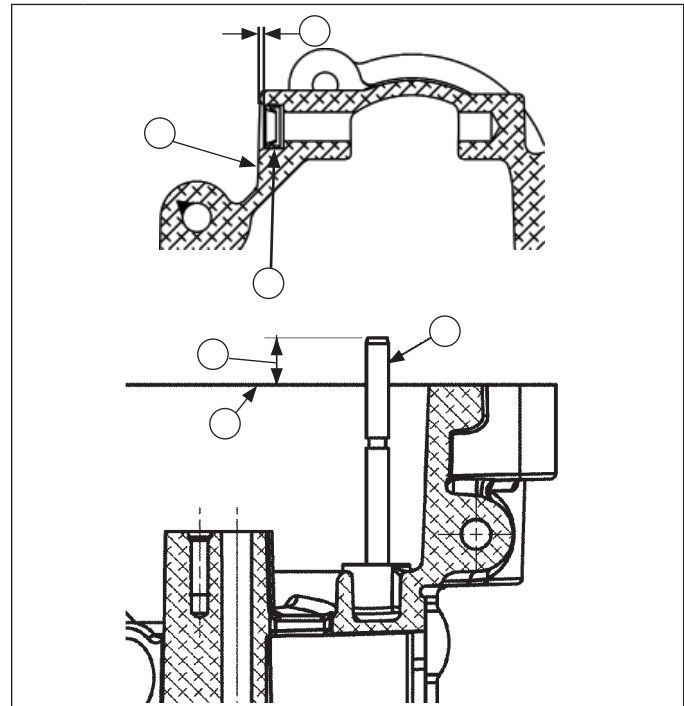

A	Crankcase Surface	B	Seal Depth 1.5 - 2.9 mm (0.059-0.078)
C	Oil Seal	D	12.66 mm (0.498 in.)
E	Crankcase Surface	F	Governor Gear Shaft

Governor Gear Shaft If governor shafts, seal, and/or governor gear were removed, reassemble as follows.

1. Lightly coat outside diameter of new governor cross shaft seal with P80 Emulsion Lubricant (refer to Tools and Aids). Install seal into crankcase to depth shown.
2. If governor gear shaft was removed, press or lightly tap replacement shaft into closure plate to depth shown.
3. Lubricate governor cross shaft bearing surfaces in crankcase with engine oil. Insert governor cross shaft end with flat cutout where governor yoke is secured, into crankcase and position shaft so that flat part is visible (up).
4. Attach governor yoke to cross shaft so curved section is up as marked. Secure with 2 screws. If a thread locking compound is not preapplied, apply a small amount of Loctite® 266™ Threadlocker or equivalent, to screw threads before installing. Torque screws to 2.2 N·m (20 in. lb.).

5. Install first regulating pin with head down so it will contact yoke. Install governor gear with second regulating pin and flyweight assembly in/down onto governor shaft until it locks into position. Apply a small amount of grease to locking tab thrust washer and install on top of governor gear so tang is facing up in 6 o'clock position.

Install Crankshaft

Carefully slide flywheel end of crankshaft through bearing in crankcase.

Install Connecting Rods with Pistons and Rings

Piston Details

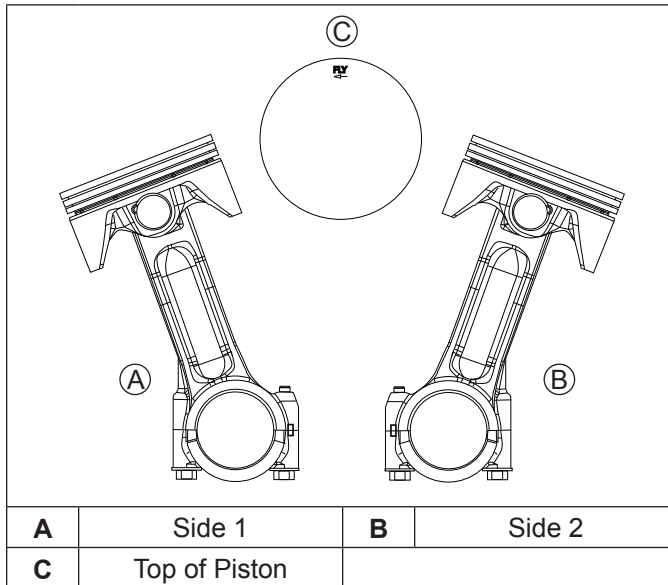

NOTE: Cylinders are numbered on crankcase. Make sure to install piston, connecting rod and end cap into appropriate cylinder bore as previously marked at disassembly. Do not mix end caps and connecting rods.

NOTE: Proper orientation of piston/connecting rod assemblies inside engine is extremely important. Improper orientation can cause extensive wear or damage. Be certain pistons and connecting rods are assembled exactly as shown.

1. If piston rings were removed, refer to Disassembly/Inspection and Service procedure to install new rings.
2. Lubricate cylinder bore, piston, and piston rings with engine oil. Compress rings of piston side 1 using a piston ring compressor.
3. Lubricate crankshaft journals and connecting rod bearing surfaces with engine oil.
4. Make sure FLY stamping on piston is facing toward flywheel side of engine. Use a hammer with a rubber grip and gently tap piston into cylinder. Be careful oil ring rails do not spring free between bottom of ring compressor and top of cylinder.
5. Install inner rod cap to connecting rod using screws. Torque screws in increments to 11.6 N·m (103 in. lb.).

Align chamfer of connecting rod with chamfer of its mating end cap. When installed, flat faces of connecting rods should face each other. Faces with raised rib should be toward outside.

7. Repeat this procedure for other connecting rod and piston assembly.

Install Camshaft

1. Liberally apply camshaft lubricant (see Tools and Aids) to each cam lobe. Lubricate camshaft bearing surfaces of crankcase and camshaft with engine oil.
2. Position timing mark of crankshaft gear at 12 o'clock position.
3. Slide camshaft into bearing surface of crankcase, positioning timing mark of camshaft gear at 6 o'clock position. Make sure camshaft gear and crankshaft gear mesh, with both timing marks aligned.

Determining Camshaft End Play

1. Place a new closure plate gasket into position on crankcase.
2. Position camshaft end play checking tool over camshaft. Use a feeler gauge to check end play between camshaft and end play checking tool. Camshaft endplay should be between 0.3/1.3 mm (0.011/0.051 in.).
3. No shim is typically used from factory. However, if camshaft end play is not within specified range, remove checking tool and shim as necessary.
3. Several color coded shims are available:
4. Reinstall end play checking tool and recheck end play.

White: 0.69215/0.73025 mm (0.02725/0.02875 in.)

Blue: 0.74295/0.78105 mm (0.02925/0.03075 in.)

Red: 0.79375/0.83185 mm (0.03125/0.03275 in.)

Yellow: 0.84455/0.88265 mm (0.03325/0.03475 in.)

Green: 0.89535/0.99345 mm (0.03525/0.03675 in.)

Gray: 0.94615/0.98425 mm (0.03725/0.03875 in.)

Black: 0.99695/1.03505 mm (0.03925/0.04075 in.)

Reassembly

Breather/Closure Plate/Oil Reservoir Components

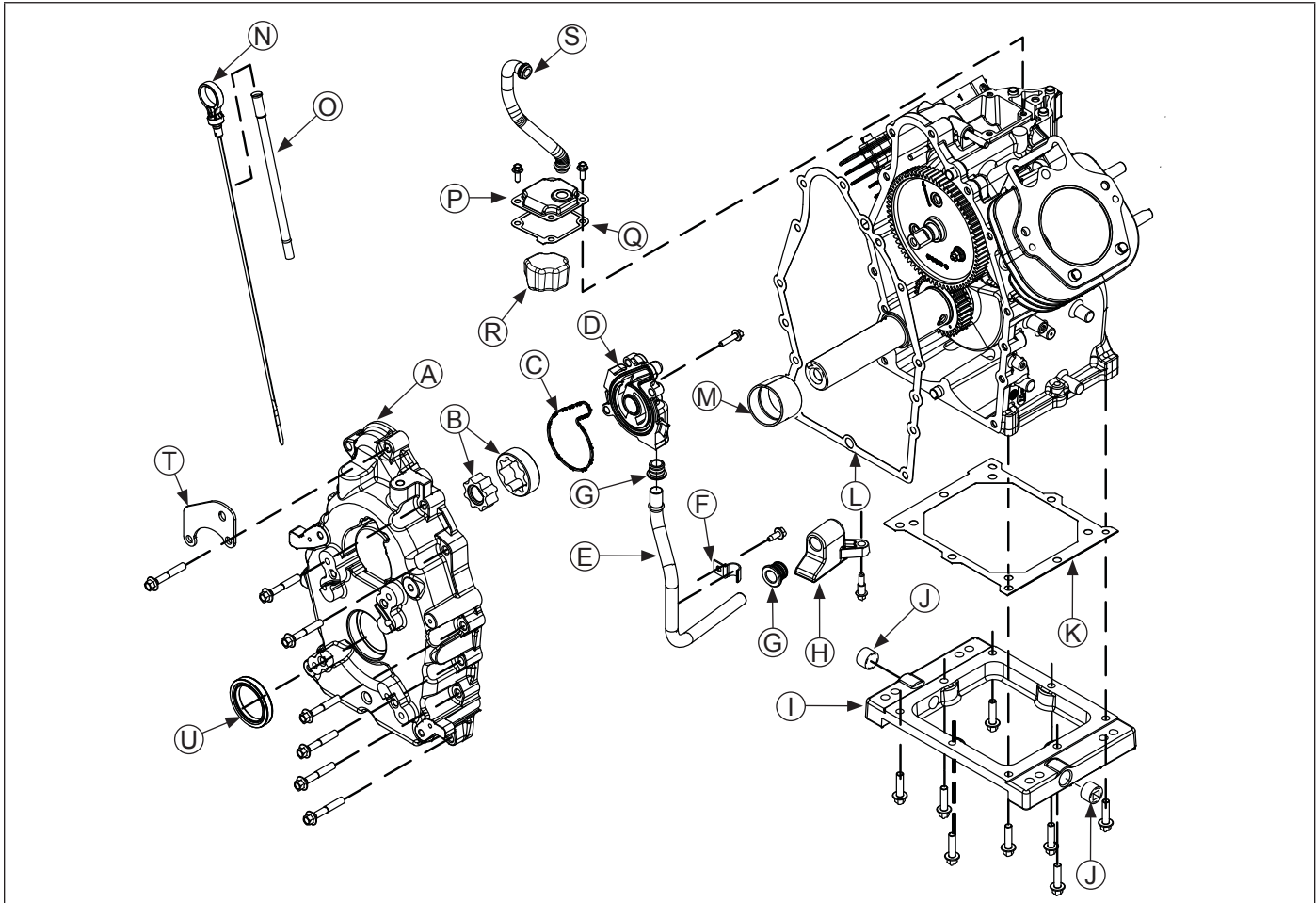

A	Closure Plate	B	Gerotor Gears	C	Oil Pump O-ring	D	Oil Pump Housing
E	Pickup Tube	F	Clamp Drain	G	Inlet Seal	H	Pickup Screen
I	Oil Reservoir	J	Plug	K	Gasket	L	Closure Plate Gasket
M	Crankshaft Non-Thrust Bearing (PTO)	N	Dipstick	O	Dipstick Tube	P	Breather Assembly
Q	Breather Gasket	R	Filter	S	Breather Hose	T	Lifting Strap
U	Oil Seal						

Oil Pump Assembly

Oil pump is mounted inside closure plate. If service was required and oil pump was removed, refer to Disassembly/Inspection and Service procedure.

Install Closure Plate Assembly

Torque Sequence

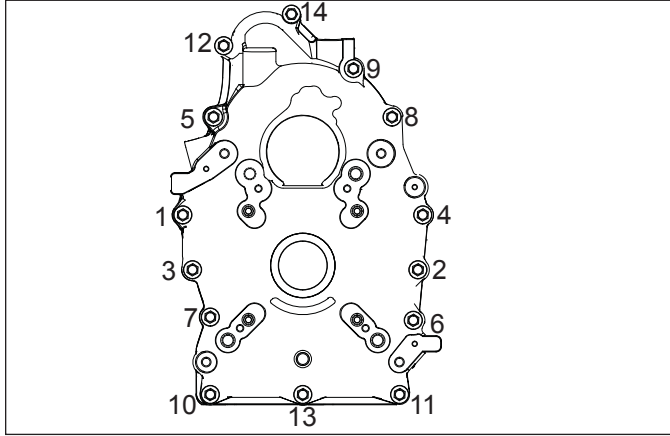

1. Make sure sealing surfaces of closure plate and crankcase are clean, dry, and free of any nicks or burrs. Install a new O-ring in closure plate.
2. Install a new closure plate gasket onto crankcase.
3. Make sure oil pump is installed and oil pickup tube faces outward at lower end.
4. Ensure end of tabbed washer on governor gear is positioned outward in 6 o'clock position inside crankcase.
5. Orient flat of oil pump gear to match position of flat on camshaft. Then install closure plate to crankcase. Carefully seat camshaft and crankshaft into their mating bearings. Rotate crankshaft slightly to help oil pump and governor gears mesh.
6. Install screws securing closure plate to crankcase. Torque screws in sequence shown to 25.6 N·m (227 in. lb.).

Install Oil Pickup Screen

Apply a small amount of oil to grommet of pickup screen and insert it onto lower end of pickup tube within crankcase. Secure pickup to boss on bottom of crankcase. Torque mounting screw to 9.3 N·m (82 in. lb.) into new holes and 7.7 N·m (68 in. lb.) into used holes.

Install Oil Reservoir

Torque Sequence

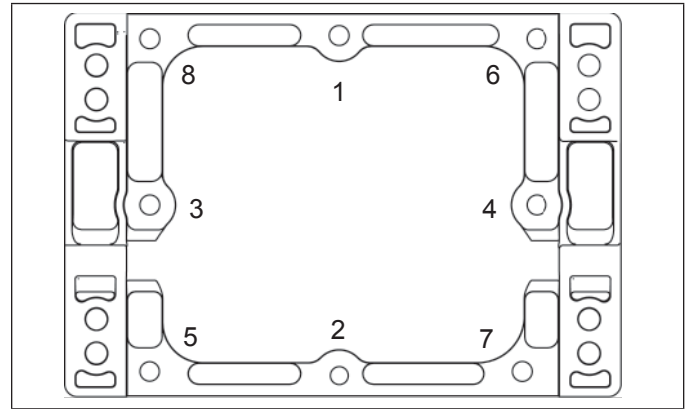

1. Use bolts with heads removed, or a similar item as temporary alignment pins and install into 2 center holes on ends.
2. Install a new oil reservoir gasket onto bottom of crankcase using alignment pins. Notched side of gasket must be towards flywheel.
3. Install oil reservoir onto crankcase and temporary alignment pins. Flywheel side is indicated on cover. Install and finger tighten screws. Remove alignment pins and install remaining screws. Torque screws in sequence shown to 25.6 N·m (227 in. lb.).

Check Crankshaft End Play

Set engine on base and use a dial indicator to check crankshaft end play to 0.20/0.94 mm (0.008/0.037 in.) for non-thrust bearing.

Reassembly

Breather Components

**Breather Fastener
Torque Sequence**

A	Breather Hose	B	Screws	C	Breather Cover	D	Breather Chamber Gasket
E	Filter						

Install Breather Assembly

1. Make sure sealing surfaces of crankcase and breather cover are clean and free of any nicks or burrs. Do not scrape surfaces, as this could result in leakage.
2. Install breather chamber gasket as shown. Assemble and install breather assembly components as illustrated. Make sure filter does not extend above top surface and all parts are properly aligned.
3. Install screws then torque using sequence shown to 12.4 N·m (110 in. lb.).
4. Lightly oil lower end of breather hose and install into hole in breather assembly. Cover should be situated between 2 raised rings of hose as illustrated.

Install Engine (oil) Temperature Sensor

NOTE: Ensure part is clean, undamaged and free of debris and make sure electrical connector has seal in place.

1. Lightly lubricate engine (oil) temperature sensor O-ring and install sensor in breather cover.
2. Torque sensor to 7.3 N·m (65 in. lb.).

Cylinder Head Components

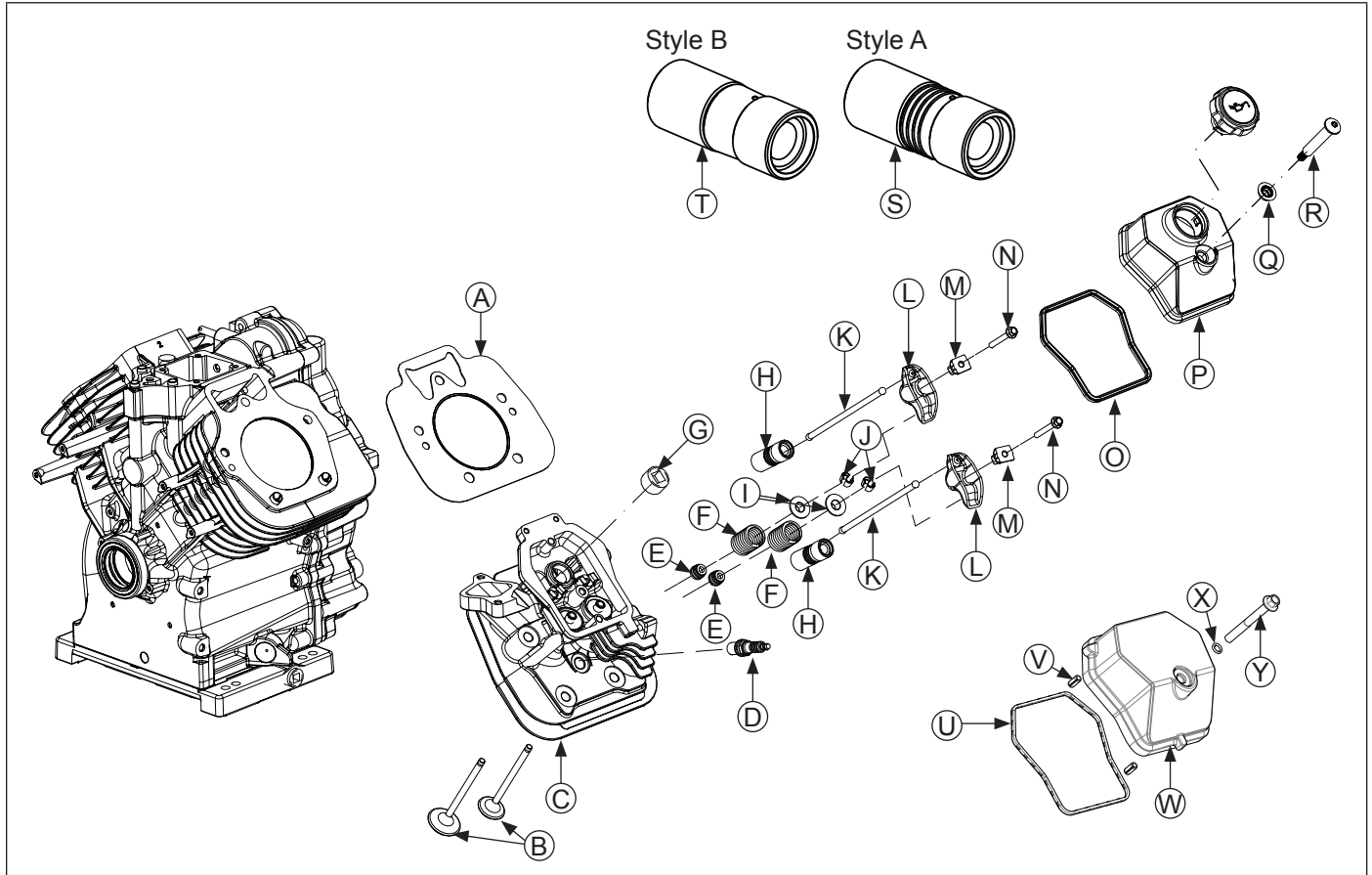

A	Gasket	B	Valve	C	Cylinder Head	D	Spark Plug
E	Valve Stem Seal	F	Valve Spring	G	Pipe Plug	H	Hydraulic Lifter
I	Valve Spring Cap	J	Valve Spring Keeper	K	Push Rod	L	Rocker Arm
M	Rocker Arm Pivots	N	Rocker Arm Screw	O	Valve Cover Seal (Plastic Valve Cover)	P	Valve Cover (Plastic)
Q	Grommet (Plastic Valve Cover)	R	Screw (Plastic Valve Cover)	S	Hydraulic Lifter Style A (Ribbed)	T	Hydraulic Lifter Style B (Smooth)
U	Valve Cover Seal (Aluminum Valve Cover)	V	Roll Pin (Aluminum Valve Cover)	W	Valve Cover (Aluminum)	X	O-Ring (Aluminum Valve Cover)
Y	Screw (Aluminum Valve Cover)						

Reassembly

Install Hydraulic Lifters

NOTE: Hydraulic lifters should always be installed in same position as they were disassembled. Exhaust lifters are located on output shaft side of engine while intake lifters are located on fan side of engine. Cylinder numbers are embossed on top of crankcase and each cylinder head.

Refer to Disassembly/Inspection and Service for lifter preparation (bleed down) procedures.

Apply camshaft lubricant (see Tools and Aids) to bottom surface of each lifter. Lubricate hydraulic lifters and lifter bores in crankcase with engine oil.

Note mark or tag identifying hydraulic lifters as either intake or exhaust and cylinder 1 or cylinder 2. Install hydraulic lifters into their appropriate location in crankcase. Do not use a magnet.

Valve Stem Seals

These engines use valve stem seals on intake and exhaust valves. Always use new seals whenever valves are removed from cylinder head. Seals should also be replaced if worn or damaged. Never reuse an old seal.

Assemble Cylinder Heads

Prior to installation, lubricate all components with engine oil, paying particular attention to lip of valve stem seal, valve stems, and valve guides. Install in order listed below using a valve spring compressor.

- Intake and exhaust valves.
- Valve stem seals.
- Valve springs.
- Valve spring caps.
- Valve spring keepers.

Install Cylinder Heads

Torque Sequence

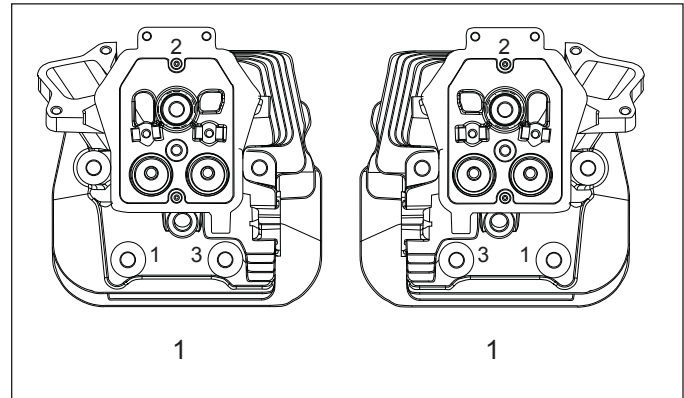

NOTE: Match numbers embossed on cylinder heads and crankcase.

1. Check to make sure there are no nicks or burrs on sealing surfaces of cylinder head or crankcase.
2. Check dowel pins are in place in 2 lower locations, and install a new cylinder head gasket, (printed side up).
3. Install cylinder head. Make sure head is flat on gasket and dowel pins. Install a flat washer on screws in locations 1 and 3. Install spacer followed by a flat washer on screw in location 5. Start 5 screws.
4. Torque screws in 2 stages, first to 23.7 N·m (210 in. lb.), finally to 46.9 N·m (415 in. lb.) following sequence shown.
5. Repeat procedure for opposite cylinder.
6. Make sure threads of pipe plugs for cylinder heads are clean and dry. Install a plug into each cylinder head above screw on location 2 and torque to 28.5 N·m (252 in. lb.).

Install Push Rods and Rocker Arms

NOTE: Push rods should always be installed in same position as before disassembly.

1. Note mark or tag identifying push rod as either intake or exhaust and cylinder 1 or 2. Dip ends of push rods in engine oil and install, making sure each push rod ball seats in its hydraulic lifter socket.
2. Apply grease to contact surfaces of rocker arms and rocker arm pivots. Install rocker arms and rocker arm pivots on cylinder head 1, and start 2 screws.
3. Rotate crankshaft to establish TDC on compression stroke. Keyway should be aligned with cylinder 1.
4. Torque screws to the appropriate torque for style of screw.

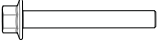
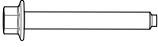
	15.5 N·m (137 in. lb.)
	11.9 N·m (105 in. lb.)

5. If push rods were not already seated, use a spanner wrench or rocker arm lifting tool, to lift rocker arms and position push rods underneath.
6. From PTO end, rotate crankshaft 270° (3/4 turn) counterclockwise and align crankshaft keyway with cylinder 2. This now puts cylinder 2 at TDC on compression stroke.
7. Repeat steps 1-5 for remaining cylinder. Do not interchange parts from cylinder heads.
8. Rotate crankshaft to check for free operation of valve train. Check clearance between valve spring coils at full lift. Minimum allowable clearance is 0.25 mm (0.010 in.).

Install Valve Covers

Plastic Valve Covers

Make sure sealing surfaces are clean and free of any nicks or burrs.

Install and properly seat seal onto each valve cover.

Install valve covers on same side as they were originally installed.

Install a new grommet on each valve cover mounting screw. Start each screw into hole.

Check position of each cover and seal, then torque screws to 13.6 N·m (120 in. lb.).

Install oil fill cap onto valve cover (if equipped).

Aluminum Valve Covers

NOTE: A new valve cover seal must be installed whenever an aluminum valve cover is removed from cylinder head.

1. Make sure sealing surfaces are clean and free of any nicks or burrs.
2. Install and properly seat a new seal into each valve cover.
3. Apply clean engine oil under screw head and on threads of each valve cover screw, O-ring, and new valve cover seal.
4. Install valve covers on same side as they were originally installed and tighten screws.
5. Check position of valve cover and seal. Into New Head: Torque screw to 26 N·m (230 in. lb.) to ensure seal seats in valve cover groove. Back off screw and then torque screw again to 18.1 N·m (160 in. lb.). Into Used Head: Torque screw to 16.4 N·m (145 in. lb.) to ensure seal seats in valve cover groove. Back off screw and then torque screw again to 16.4 N·m (145 in. lb.).

Install Spark Plugs

1. Check gap using wire feeler gauge. Adjust gap to 0.76 mm (0.030 in.).
2. Install plug into cylinder head.
3. Torque plug to 27 N·m (20 ft. lb.).

Reassembly

Oil Filter Components

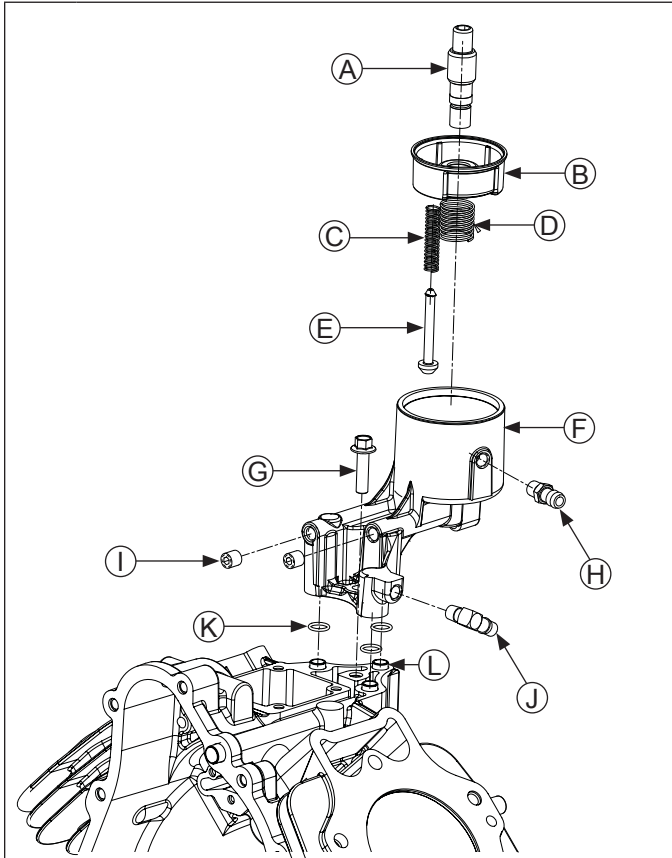

A	Oil Filter Nipple	B	Oil Filter Cup
C	Oil Filter Valve Spring	D	Oil Filter Cup Spring
E	Oil Filter Valve	F	Oil Filter Housing
G	Screw Pipe	H	Straight Fitting
I	Plug	J	Barbed Fitting
K	O-Ring	L	Dowel

Install Oil Filter Housing Assembly

Reassemble oil filter housing if disassembled previously.

Reassembly

1. Install small spring onto rubber valve, and insert small end through corresponding hole in cup until properly seated.
2. Install larger spring into filter housing.
3. Insert oil filter cup, aligning cutout with corresponding section in housing.
4. Install nipple in housing and torque to 17.8 N·m (158 in. lb.).
5. If fittings and plug were removed, insert O-ring, barbed fitting, and pipe plug into housing assembly.

Installation

1. Make sure all sealing surfaces are clean and all dowel pins are in position. Install or check new O-rings are around all oil filter adapter dowel pins.
2. Install oil filter housing assembly and secure with M8 screw. Make sure housing is flat on crankcase and all O-rings remain in position. Torque screw to 23.7 N·m (210 in. lb.).

Flywheel, Backing Shroud, and Baffle Components

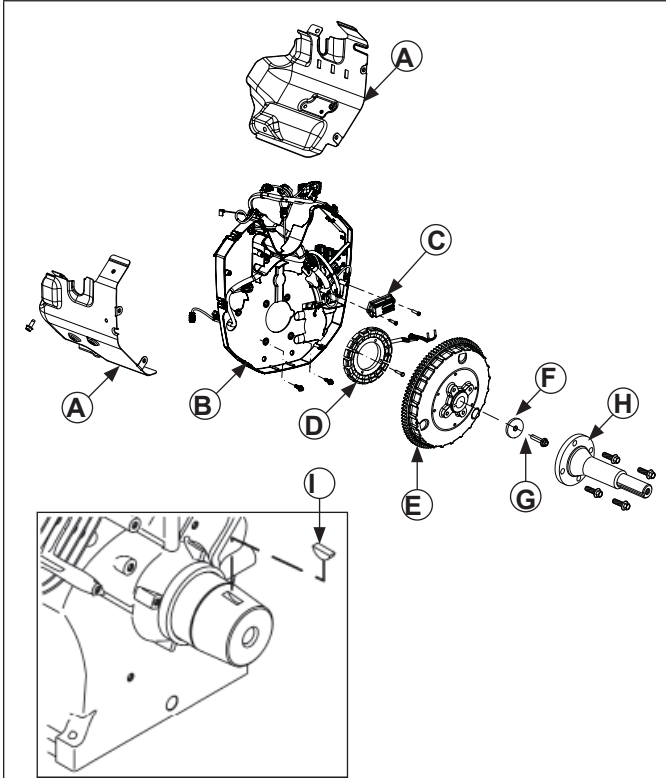

A	Barrel Baffles	B	Backing Shroud
C	Rectifier-Regulator	D	Stator
E	Flywheel	F	Washer
G	Flywheel Screw	H	Front Drive Shaft (if equipped)
I	Woodruff Key		

Install Backing Shroud

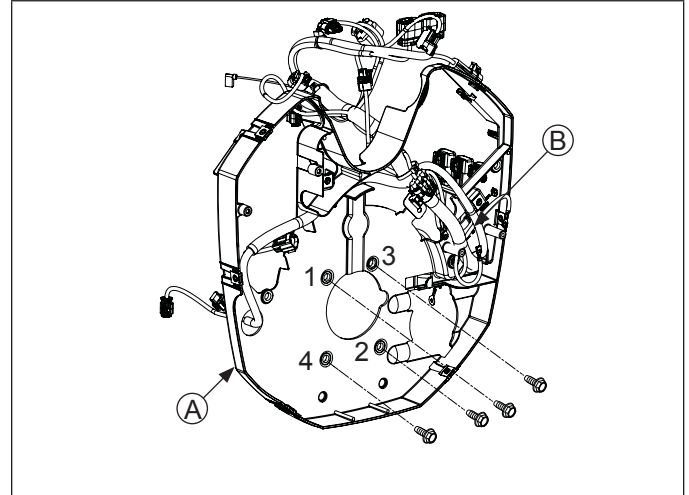

A	Backing Shroud	B	Wiring Harness
----------	----------------	----------	----------------

NOTE: New hose clamps are recommended for reassembly, or if clamps have been loosened (expanded) several times to avoid leakage.

1. To aid assembly, and if it was removed, install lower oil cooler hose onto oil filter housing prior to installing backing shroud assembly, and secure with a clamp. Position clamp as noted in disassembly.
2. Install backing shroud assembly and secure to crankcase with M6 screws. Torque screws, in sequence shown, to 10.7 N·m (95 in. lb.) into new holes, or 7.3 N·m (65 in. lb.) into used holes.

Install Barrel Baffles

1. Position barrel baffles and start each screw.
2. Torque M6 screws going into cylinder head and crankcase to 10.7 N·m (95 in. lb.) for new holes, or 7.3 N·m (65 in. lb.) for used holes.
3. Torque M6 shoulder screws going through backing shroud assembly into extruded holes in baffles to 2.5 N·m (22 in. lb.) into new holes, or 2.0 N·m (18 in. lb.) into used holes.
4. If removed, install ignition coils to barrel baffles and secure with clip and screw. Torque screw to 5.1 N·m (45 in. lb.).
5. Connect wiring harness leads to ignition coils.
6. Install fuses into fuse holder covers on barrel baffle.

Reassembly

Install Stator

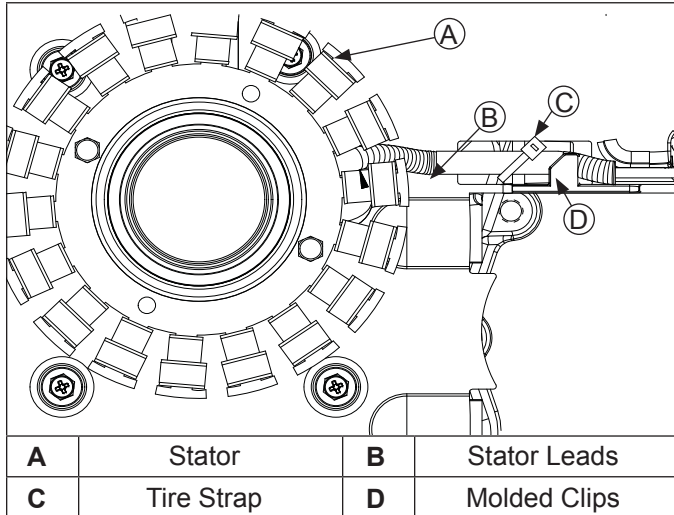

1. Apply pipe sealant with Teflon® (Loctite® PST® 592™ Thread Sealant or equivalent) to stator mounting holes.
2. Position stator, aligning mounting holes so leads are at 3 o'clock position and toward rectifier-regulator mount on cylinder 1 side.
3. Install and torque screws to 9.3 N·m (82 in. lb.).
4. Route stator wires under molded clips and install new tie strap.

Install Wiring Harness

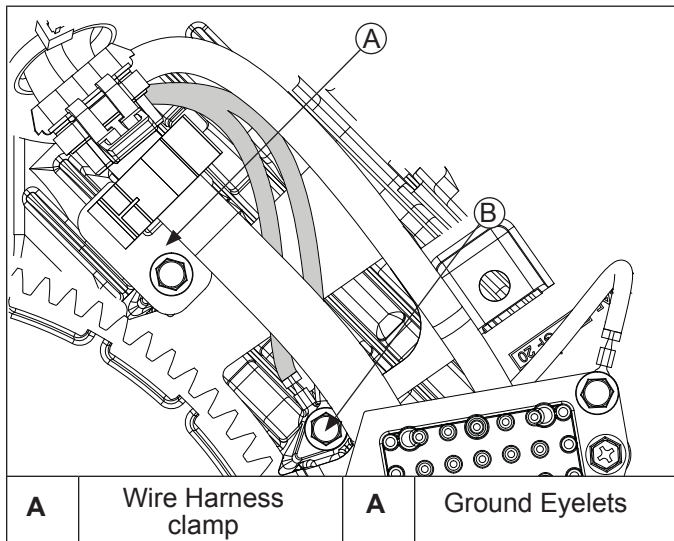

1. Install wire harness under molded clips in backing shroud assembly.
2. Install wire harness clamp and wire harness ground eyelets. Torque M6 screws to 2.5 N·m (22 in. lb.) into new holes, or 2.0 N·m (18 in. lb.) into used holes.

Install Rectifier-Regulator

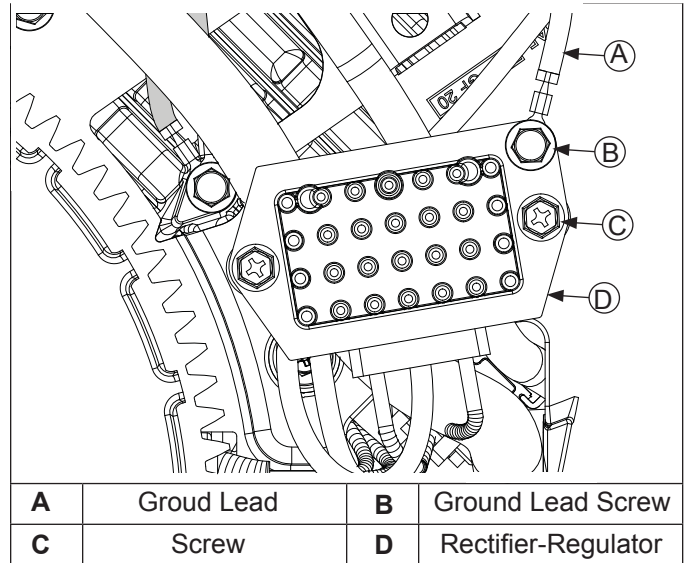

1. If purple wire was removed, verify locking tang is raised on terminal and push wire terminal into plug prior to connecting to rectifier-regulator.
2. Position rectifier-regulator onto mounting posts and secure with screws. Torque mounting screws to 2.5 N·m (22 in. lb.).
3. Engine has ground lead that secures in ground lug fastener hole. Attach ground lead to rectifier-regulator and torque to 5.6 N·m (50 in. lb.) into new holes, or 4.0 N·m (35 in. lb.) into used holes.
4. Connect plug to rectifier-regulator.

Install Flywheel

	<p>CAUTION</p> <p>Damaging Crankshaft and Flywheel Can cause personal injury.</p>
<p>Using improper procedures can lead to broken fragments. Broken fragments could be thrown from engine. Always observe and use precautions and procedures when installing flywheel.</p>	

NOTE: Before installing flywheel make sure crankshaft taper and flywheel hub are clean, dry, and completely free of any lubricants. Presence of lubricants can cause flywheel to be over stressed and damaged when screw is torqued to specifications.

NOTE: Make sure flywheel key is installed properly in keyway. Flywheel can become cracked or damaged if key is not properly installed.

1. Install woodruff key into crankshaft keyway. Make sure key is properly seated and parallel with shaft taper.
2. Install flywheel onto crankshaft, being careful not to shift woodruff key.

3. Install screw and washer.
4. Use a flywheel strap wrench or holding tool to hold flywheel. Torque screw to 69.8 N·m (51 ft. lb.).
5. If equipped, install front drive shaft. Secure with screws and torque to 24.4 N·m (216 in. lb.).

Install Crankshaft Position Sensor

NOTE: Ensure all parts are clean, undamaged and free of debris and make sure electrical connectors have seal in place.

1. If removed, install crankshaft position sensor to bracket and torque screws to 11.3 N·m (100 in. lb.).
2. Install crankshaft position sensor and bracket assembly to crankcase posts. Torque bracket screws to 9.9 N·m (88 in. lb.).
3. Push electrical connector on crankshaft position sensor making sure a good connection is made.

Install Debris Screen and Fan Option #1



CAUTION

Failure to utilize or reassemble debris screen as designed could result in debris screen failure and serious personal injury.

Debris Screen and Fan Components

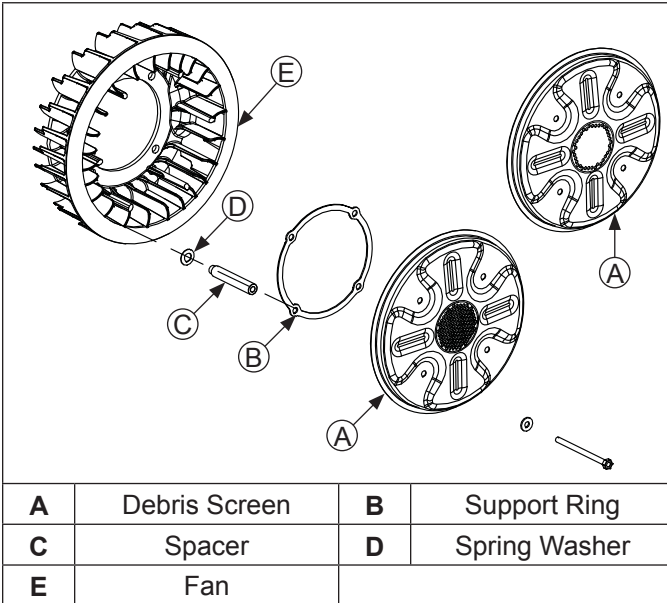

Spring Washer Details

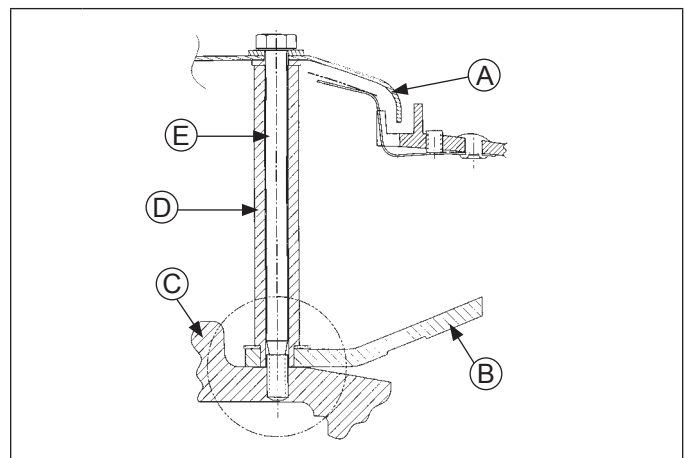
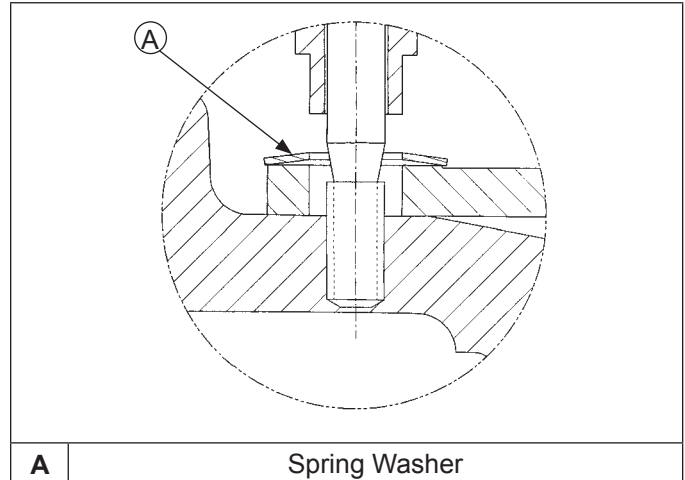

NOTE: Use this reassembly sequence if fan and debris screen disassembled individually.

NOTE: Position locating tabs on back of fan into locating holes of flywheel.

1. Verify locating tabs on back of fan are inserted into locating holes on flywheel.
2. To assist assembly, find intake manifold studs with M6 thread at least 100 mm in length to be used as guide pins. Insert intake manifold studs through cooling fan mounting holes and thread them 4 or 5 turns into flywheel.
3. Install a spring washer on each stud with concave side down toward cooling fan.
4. Install a spacer on each stud with stepped end down. Smaller diameter should extend through spring washer and fan, so tip is resting on flywheel, and shoulder is resting on spring washer.
5. Install support ring on studs, so it is resting on spacers. Then install metal screen on top of support ring.

Reassembly

6. Install a plain washers on each of screws. Apply Loctite® 242® to screw threads.
7. Carefully remove studs and replace with screws. Torque screws to 9.9 N·m (88 in. lb.). Repeat procedure for other studs and screws.

Install Debris Screen and Fan Option #2

	⚠ CAUTION
	Failure to utilize or reassemble debris screen as designed could result in debris screen failure and serious personal injury.

Debris Screen and Fan Components

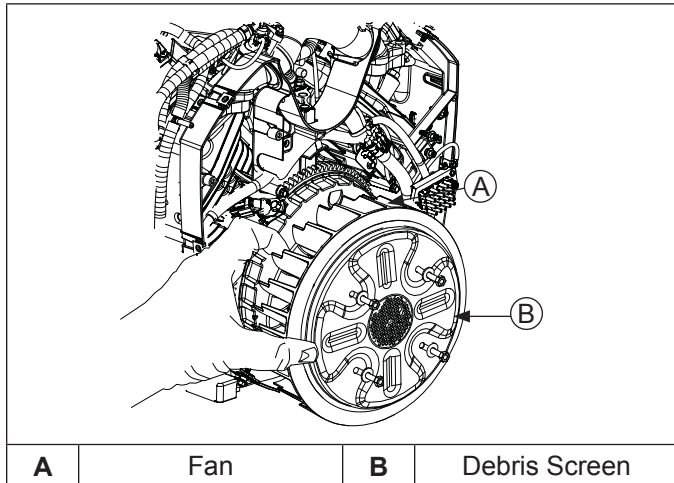

Fan Mounting Holes Detail

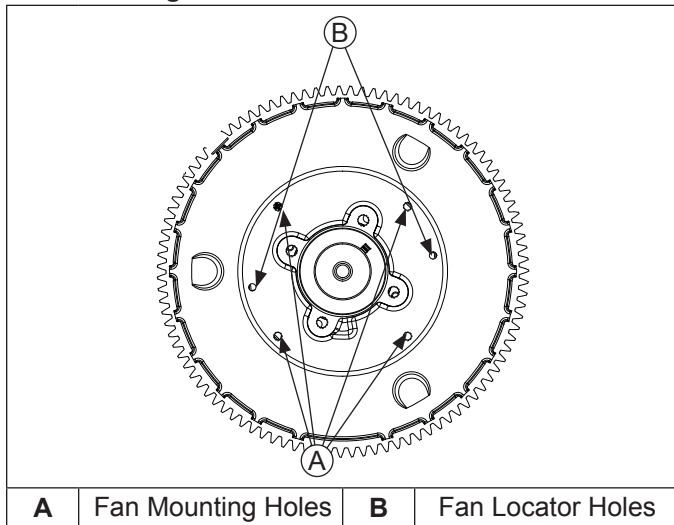

NOTE: Use this reassembly sequence if fan and debris screen were kept as a complete assembly and not replaced individually.

1. Inspect flywheel position on engine. Note two fan pilot hole locations on face of flywheel.
Pilot holes accept two locator pins which are molded into mating surface of engine cooling fan.
2. Using two hands, pick up fan, screen, and hardware as a complete assembly (as described in Disassembly section).
3. Arrange assembly vertically to position fan mating surface against flywheel fan mounting surface.
4. Turn fan/screen assembly. Pay close attention to locator pins on fan and ensure that they mate to locator holes on face of flywheel.
5. While holding fan/screen assembly in position against flywheel, start fan/screen mounting screws into flywheel.
6. Screw all four screws finger tight making sure fan locator pins are aligning with locator holes in flywheel. Torque screws to 9.9 N·m (88 in. lb.).

Intake Manifold Components

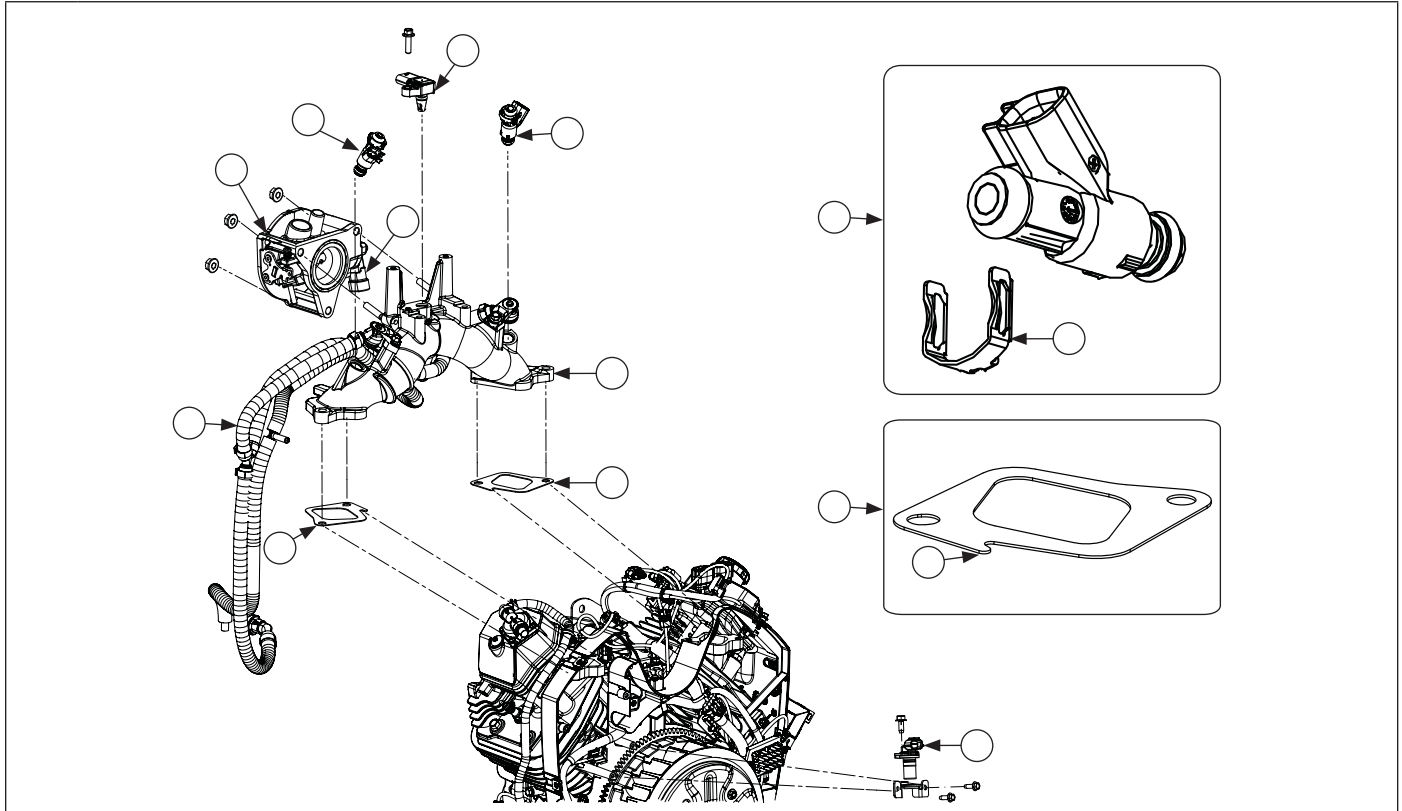

A	Crankshaft Position Sensor	B	Intake Manifold Gasket	C	Intake Manifold	D	Fuel Rail
E	TPS Sensor	F	Throttle Body	G	Fuel Injector	H	Metal Retaining Clip
I	TMAP Sensor	J	Gasket Notch				

Install Intake Manifold

Torque Sequence

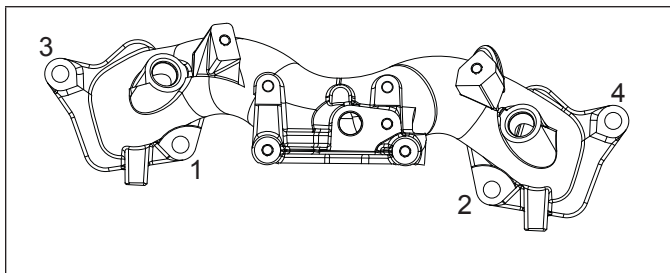

1. Install new intake manifold gaskets so notched section is inward and points toward flywheel side.
2. Install intake manifold to cylinder heads. Make sure gaskets remain in proper position. Torque intake manifold screws in 2 stages using sequence shown, first to 16.9 N·m (150 in. lb.), finally to 22.6 N·m (200 in. lb.).
3. Install throttle body studs into intake manifold if previously removed. Use nuts, locked flange to flange, and tighten each stud until bottomed/tight.

Install Fuel Injectors

NOTE: Ensure all parts are clean, undamaged and free of debris and make sure electrical connectors have seal in place.

NOTE: O-rings and retaining clips should be replaced any time fuel injector is separated from its normal mounting position.

1. Lightly lubricate fuel injector O-rings with clean engine oil.
2. Push retaining clip onto fuel injector, aligning clip as shown.
3. Press fuel injector into fuel injector cap until retaining clip snaps into place.
4. Press fuel injector into bore in intake manifold and rotate to original position, as noted in Disassembly/Inspection and Service.
5. Install fuel injector cap screw into intake manifold and torque to 7.3 N·m (65 in. lb.).
6. Push electrical connector on fuel injector making sure a good connection is made. Ensure injector connector is in proper position based on identification steps made in Disassembly.
7. Repeat steps 1 through 6 for other fuel injector.

Reassembly

Install Fuel Pump Module (FPM)

	⚠ WARNING
Explosive Fuel can cause fires and severe burns. Do not fill fuel tank while engine is hot or running.	
Gasoline is extremely flammable and its vapors can explode if ignited. Store gasoline only in approved containers, in well ventilated, unoccupied buildings, away from sparks or flames. Spilled fuel could ignite if it comes in contact with hot parts or sparks from ignition. Never use gasoline as a cleaning agent.	

FPM Components

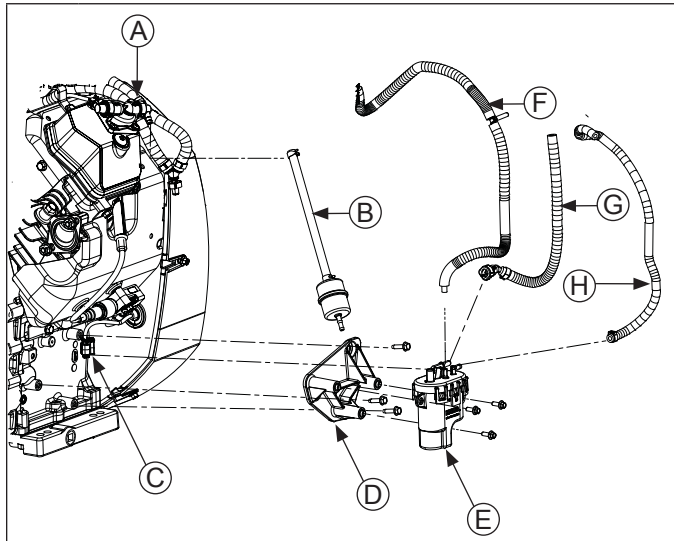

A	Fuel Pump	B	Inlet Fuel Line
C	Electrical Connector	D	FPM Baffle
E	FPM	F	Vent Hose
G	High Pressure Fuel Line	H	Outlet Fuel Line to FPM

NOTE: Ensure all parts are clean, undamaged and free of debris and make sure electrical connector has seal in place.

NOTE: FPM pins should be coated with a thin layer of electrical grease to prevent fretting and corrosion and may be reapplied if FPM is being reused.

1. Install screws to secure FPM baffle to crankcase. Torque screws to 11.3 N·m (100 in. lb.).
2. If removed, push high pressure fuel line connector onto FPM fitting.
3. If Oetiker clamp was cut to remove inlet fuel line, slide a new Oetiker clamp onto fuel line and connect fuel line. Only use an Oetiker clamp pliers to crimp Oetiker clamps. Oetiker clamp crimp must point up, away from top of FPM and abrasion sleeve must be positioned over Oetiker clamp.
4. Connect electrical connector to top of FPM. Ensure grey locking tab is pulled out before connecting. Push connector onto terminal until a click is heard, then push in grey locking tab to lock connector.
5. Install FPM to baffle using screws. Torque screws to 9.2 N·m (81 in. lb.).
6. Install vent line to top of FPM.
7. Install fuel lines into clip and secure to barrel baffle.

External Engine Components

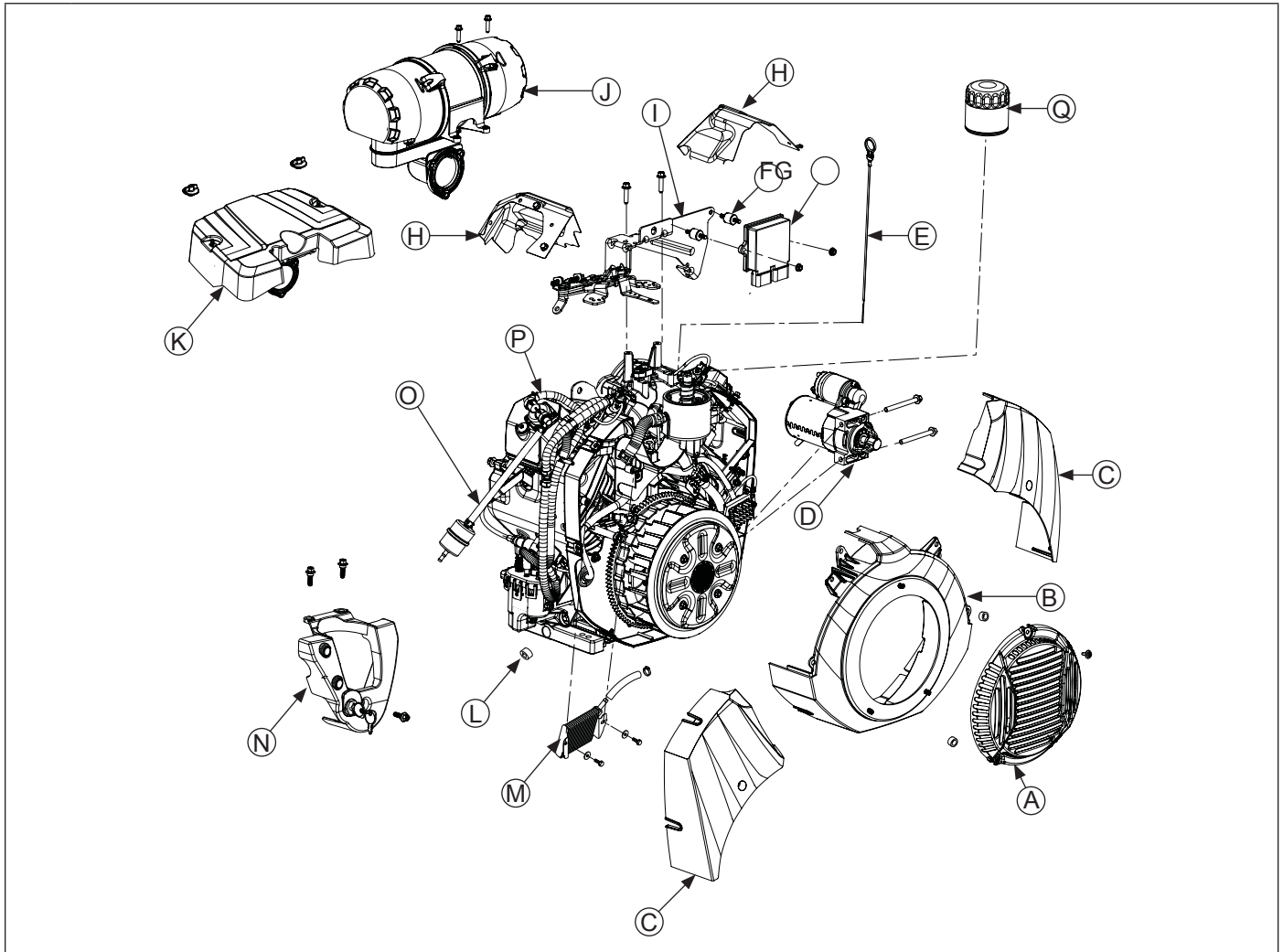

A	Fixed Guard	B	Blower Housing	C	Cylinder Shroud	D	Electric Starter
E	Dipstick	F	Electronic Control Unit (ECU)	G	Vibration Stud Isolator	H	Valley Baffle
I	Control Bracket	J	Heavy-Duty Air Cleaner	K	Low-Profile Air Cleaner	L	Drain Plug
M	Oil Cooler	N	Control Panel (if equipped)	O	Inlet Fuel Line	P	Outlet Fuel Line
Q	Oil Filter						

Reassembly

Install #2 Valley Baffle

Install cylinder #2 valley baffle with two screws and torque screws to 2.5 N·m (22 in. lb.) into new holes, or 2.0 N·m (18 in. lb.) into used holes.

Install #1 Valley Baffle

1. Install 1 screw to secure cylinder #1 valley baffle to backing shroud. Torque screw to 2.5 N·m (22 in. lb.) into new hole, or 2.0 N·m (18 in. lb.) into used hole.
2. Install fuse holder bracket over baffle and secure with 2 screws. Torque screws to 10.7 N·m (95 in. lb.) into new holes, or 7.3 N·m (65 in. lb.) into used holes.
3. Secure dipstick tube to fuse holder bracket. Once positioned, slide down spring hose clamp to secure.
4. If equipped, install fuses into fuse covers on fuse holder bracket.
5. Insert clips into baffle to secure wire harness.
6. Push connector on engine temperature sensor making sure a good connection is made and click is heard. Secure lock tab.

Install Throttle Body

NOTE: Ensure all parts are clean, undamaged and free of debris and make sure electrical connector has seal in place.

1. Install a new throttle body O-ring prior to installation.
2. Install throttle body and throttle linkage.
3. Install vent hose assembly to throttle body.
4. Push electrical connector onto throttle position sensor (TPS) making sure a good connection is made.

Install Governor Lever

Install governor lever onto governor shaft and connect throttle linkage with black linkage bushing and dampening spring. Do not tighten governor lever at this time.

Install Temperature/Manifold Absolute Pressure (TMAP) Sensor

NOTE: Ensure all parts are clean, undamaged and free of debris and make sure electrical connector has seal in place.

1. Lightly oil TMAP sensor O-ring and push sensor into bore in intake manifold.
2. Torque screw to 7.3 N·m (65 in. lb.).
3. Push electrical connector on TMAP sensor making sure a good connection is made. Slide down lock tab.

Install Fuel Lines to Fuel Pump

1. Reinstall low pressure fuel line to fuel pump. Slide clamp to secure in place.
2. Install fuel line into clips and secure to valley baffle.

Control Bracket Components

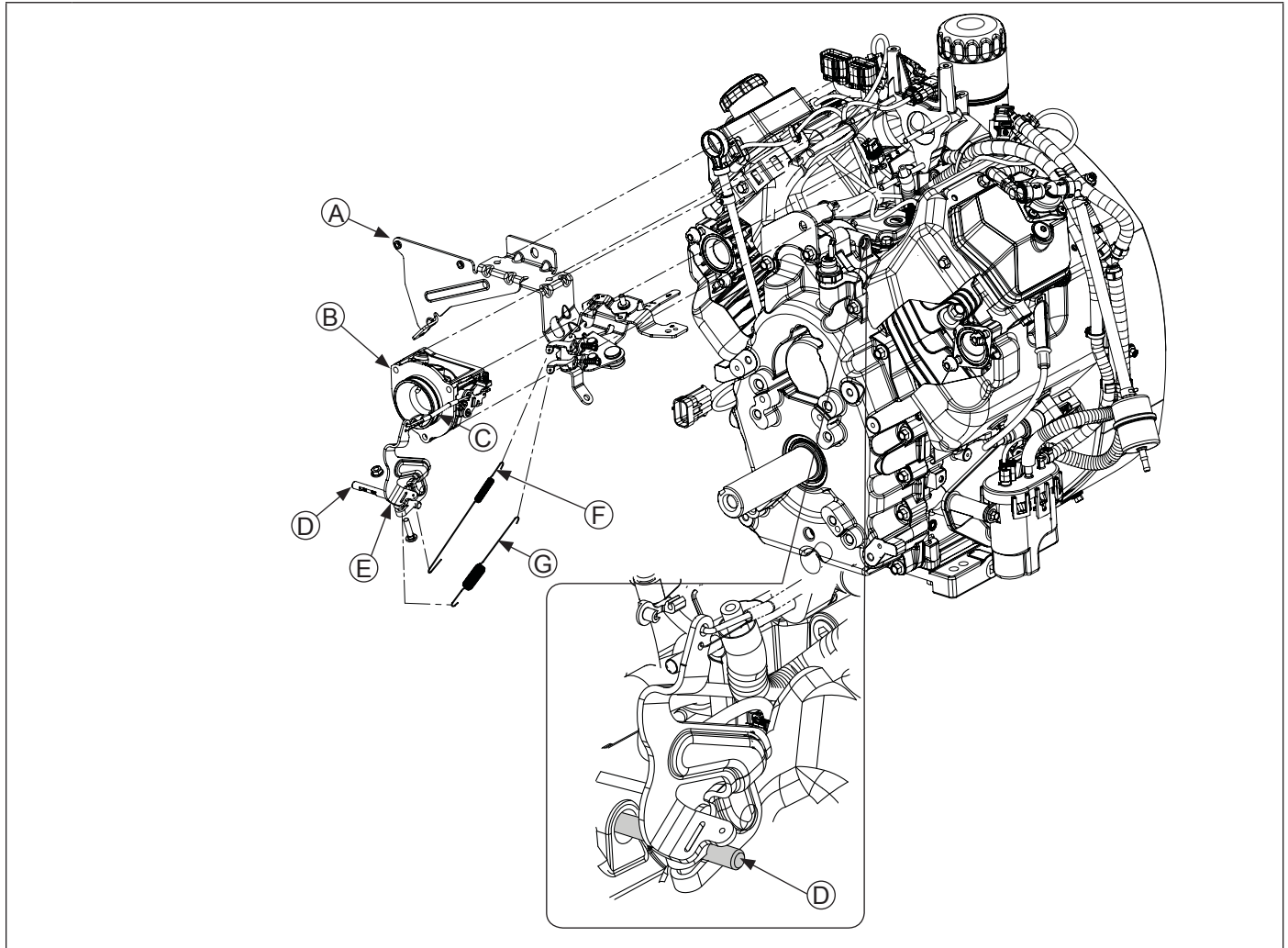

A	Control Bracket	B	Throttle Body	C	Throttle Linkage and Linkage Spring	D	Cross Shaft
E	Governor Arm	F	Governor Spring	G	Governed Idle Spring		

Install Control Bracket and Air Cleaner Assembly

NOTE: Low-profile air cleaner is installed in similar manner to heavy-duty air cleaner.

NOTE: ECU pins should be coated with a thin layer of electrical grease to prevent fretting and corrosion and may need to be reapplied if ECU is being reused.

1. If removed, install ECU to control bracket using vibration stud isolators and mounting nuts. Torque nuts to 2.0 N·m (18 in. lb.).
2. Connect Black and Grey electrical connectors to ECU. Connectors and ECU are keyed in such a way so they cannot be installed incorrectly. Install wires into clips and secure to valley baffle.
3. Position control bracket assembly onto 2 intake manifold bosses. Align rear supports with top valley baffle/cylinder head mounting screw locations and install screws, but do not fully tighten.
4. Install a new air cleaner elbow gasket.
5. Slide air cleaner assembly onto throttle body mounting studs and control bracket assembly. Start three nuts on mounting studs. Start two screws in intake manifold boss/control bracket.
6. Torque 3 air cleaner nuts to 8.2 N·m (73 in. lb.).
7. Torque 2 control bracket baffle screws to 10.2 N·m (90 in. lb.).
8. Torque 2 air cleaner/control bracket screws to 11.3 N·m (100 in. lb.).
9. Connect breather hose to fitting on air cleaner outlet.

Reassembly

Install and Adjust Governor Lever Details

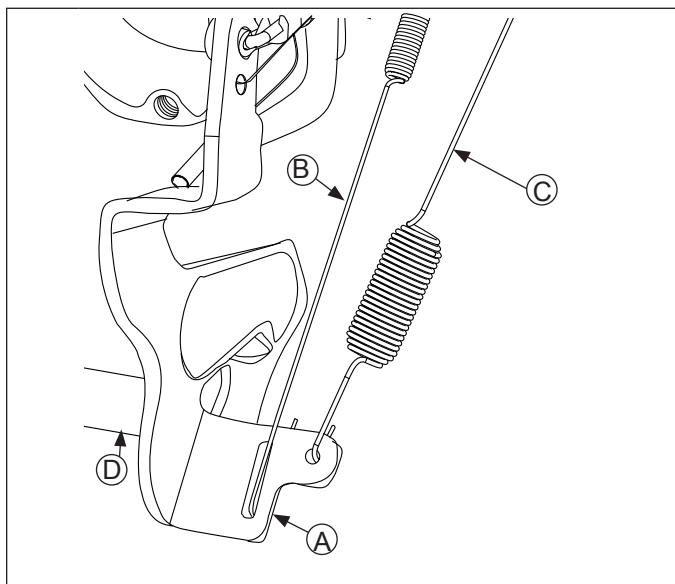

A	Governor Lever	B	Governor Spring
C	Governed Idle Spring	D	Cross Shaft

1. Position governor lever so clamping area is inboard but completely on knurled area of governor cross shaft.
2. Move governor lever toward throttle body as far as it will go (wide-open throttle) and hold in position.
3. Insert a long thin rod or tool into hole on cross shaft and rotate shaft clockwise (viewed from end) as far as it will turn, then torque nut to 7.1 N·m (63 in. lb.).
4. Connect governor spring (with long looped end), to inner hole on governor lever and control bracket.
5. Connect governed idle spring to outer governor lever hole and control bracket. Make sure springs do not contact valley baffle.

Install Oil Sentry™ (if equipped)

1. Apply pipe sealant with Teflon® (Loctite® PST® 592™ Thread Sealant or equivalent) to Oil Sentry™ threads switch and install it into 1/8 in. port in closure plate. Torque switch to 10.7 N·m (95 in. lb.).
2. Connect green wire lead to Oil Sentry™ terminal.

Install Oil Cooler

1. Connect hoses between oil filter adapter and oil cooler. Secure with new clamps in same orientation as noted in Disassembly.
2. Align oil cooler with bosses in backing shroud assembly. Secure with screws and washers. Torque screws to 2.3 N·m (21 in. lb.)

Install Blower Housing and Cylinder Shrouds

1. Align and install blower housing.
2. Secure blower housing with screws. Torque screws to 2.5 N·m (22 in. lb.) into new holes, or 2.0 N·m (18 in. lb.) into used holes.
3. Install cylinder shrouds and secure with shoulder screws. Torque screws to 2.5 N·m (22 in. lb.) into new holes, or 2.0 N·m (18 in. lb.) into used holes.

Install Electric Starter Motor

1. Install electric starter motor using screws.
2. Torque screws to 16.0 N·m (142 in. lb.).
3. Connect leads to solenoid.

Control Panel Components

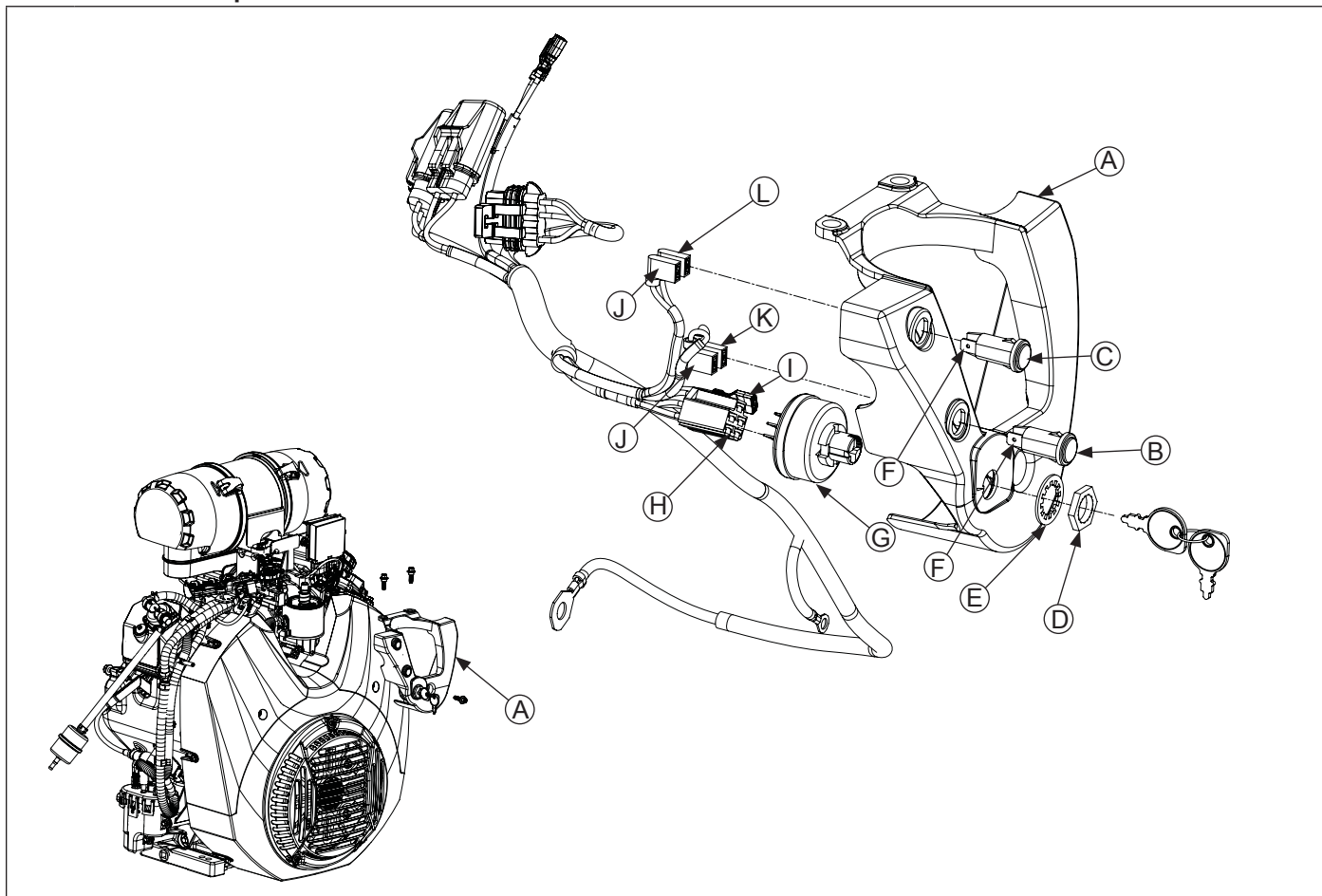

A	Control Panel	B	MIL Indicator Light	C	Oil Pressure Indicator Light	D	Nut
E	Washer	F	Indicator Positive (Red Mark) Terminal	G	Key Switch	H	5-Pin Connector
I	Ground Terminal	J	Yellow Wire	K	Tan Wire	L	Green Wire

Install Control Panel (if equipped)

1. If key switch was removed, install in control panel aligning slot in key switch housing with tab on control panel. Secure key switch with washer and nut on outside of control panel. Torque nut to 1.6 N·m (14 in. lb.).
2. Connect ground terminal and 5-pin connector to key switch.
3. Connect yellow, tan, and green wires for Oil Pressure and MIL LEDs. Ensure yellow wires are connected to positive (red mark) indicator light terminals.
4. Slide control panel up and over oil filter housing.
5. Install control panel to main control bracket and oil filter housing. Torque top 2 screws into intake manifold to 11.3 N·m (100 in. lb.). Torque bottom screw into oil filter housing to 11.3 N·m (100 in. lb.).

Install Muffler

1. Install new exhaust gaskets onto exhaust studs.
2. Install port liners (if equipped). Attach muffler and secure with nuts onto exhaust studs. Torque nuts to 24.4 N·m (216 in. lb.).
3. If equipped, install any attaching hardware and brackets. Torque M6 screws to 9.9 N·m (88 in. lb.), and M8 screws to 24.4 N·m (216 in. lb.).
4. Install oxygen sensor, torque to 50.1 N·m (37 ft. lb.), and connect to wire harness.
5. Install spark arrestor (if used).

Reassembly

Install Oil Filter and Add Oil to Crankcase

NOTE: Make sure both oil drain plugs are installed and torqued to 21.4 N·m (16 ft. lb.) to prevent oil leakage.

1. Install oil drain plugs. Torque plugs to 21.4 N·m (16 ft. lb.).
2. Place new filter in shallow pan with open end up. Fill with new oil until oil reaches bottom of threads. Allow 2 minutes for oil to be absorbed by filter material.
3. Apply a thin film of clean oil to rubber gasket on new filter.
4. Refer to instructions on oil filter for proper installation.
5. Fill crankcase with new oil. Level should be at top of indicator on dipstick.
6. Reinstall oil fill cap/plug and dipstick and tighten securely.

Connect Spark Plug Leads

Connect leads to spark plugs.

Prepare Engine for Operation

NOTE: If ECU, throttle body, TPS or fuel pump module were replaced, an ECU Reset and TPS Learn is required. Refer to EFI System Reset and TPS Learn procedure.

Engine is now completely reassembled. Before starting or operating engine, be sure to follow steps below.

1. Make sure all hardware is tightened securely.
2. Make sure oil drain plugs, Oil Sentry™ pressure switch, and a new oil filter are installed.
3. Verify crankcase has been filled with correct amount, weight, and type of oil. Refer to oil recommendations and procedures in Maintenance, Specifications, and Lubrication System.
4. Turn on fuel supply.

Testing Engine and Setting Speed

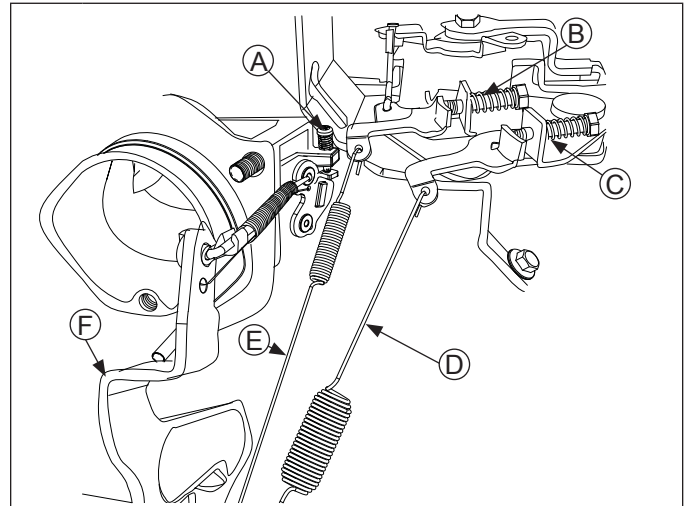

A	Idle Speed Screw	B	High Speed Screw
C	Governed Low Idle Screw	D	Governed Idle Spring
E	Governor Spring	F	Governor Lever

It is recommended engine be operated on a stand or bench prior to installation in piece of equipment.

1. Set engine up on a test stand. Install an oil pressure gauge. Start engine and check to be certain oil pressure (20 psi or more) is present. Run engine at idle for 2-3 minutes, then 5-6 minutes more between idle and midrange.
2. Adjust idle speed screw located on throttle body 100 RPM below specified idle speed setting.
3. Set governed idle speed to specified governor speed setting.
4. Adjust high speed as necessary. Make sure maximum engine speed does not exceed 3750 RPM (no load).

Governor Spring/RPM Range Chart

ECH940/ECH980	
Governor Idle Spring (Color)	Idle Speed (RPM)
Black	1626-1800 RPM
ECH940	
Governor Spring (Color)	High Speed (RPM)
Orange	3000-3300 RPM
Brown Patch	3301-3675 RPM
Red	3676-3900 RPM
ECH980	
Governor Spring (Color)	High Speed (RPM)
Purple	3000-3900 RPM



1P62 690 13



8 85612 49779 6