

## Command PRO

CH682, CH732, CH742, CH752

Service Manual

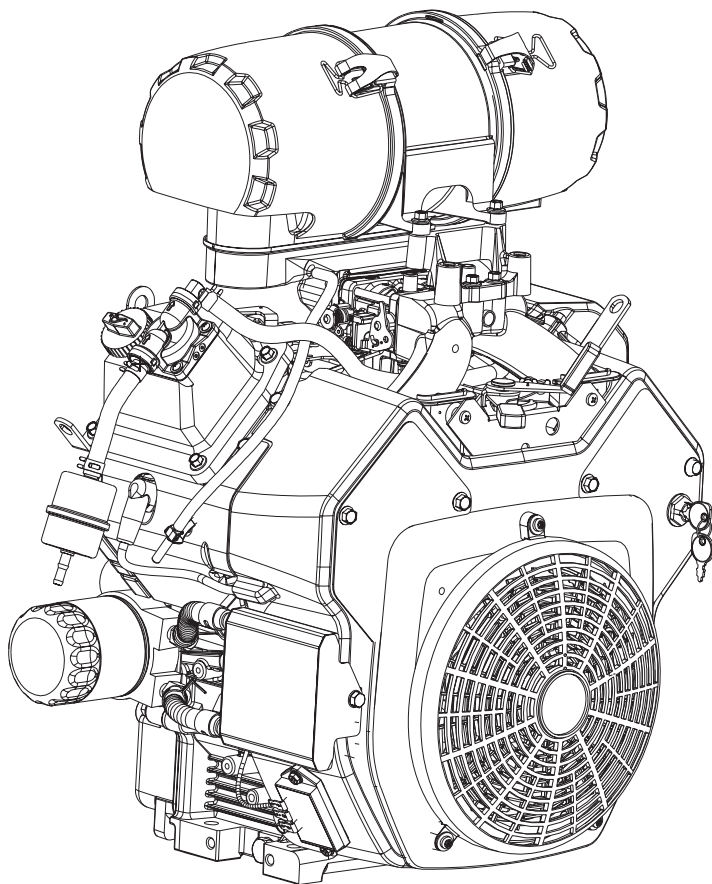

Kohler Engines  
is now Rehlko.

2	Safety
3	Maintenance
5	Specifications
13	Tools and Aids
16	Troubleshooting
20	Air Cleaner/Intake
21	Fuel System
27	Governor System
29	Lubrication System
31	Electrical System
38	Starter System
42	Disassembly/Inspection and Service
56	Reassembly

**IMPORTANT:** Read all safety precautions and instructions carefully before operating equipment. Refer to operating instruction of equipment that this engine powers.

Ensure engine is stopped and level before performing any maintenance or service.

# Safety

## SAFETY PRECAUTIONS

**⚠ WARNING:** A hazard that could result in death, serious injury, or substantial property damage.

**⚠ CAUTION:** A hazard that could result in minor personal injury or property damage.

NOTE: is used to notify people of important installation, operation, or maintenance information.

	<b>⚠ WARNING</b>
	Explosive Fuel can cause fires and severe burns. Do not fill fuel tank while engine is hot or running.
Gasoline is extremely flammable and its vapors can explode if ignited. Store gasoline only in approved containers, in well ventilated, unoccupied buildings, away from sparks or flames. Spilled fuel could ignite if it comes in contact with hot parts or sparks from ignition. Never use gasoline as a cleaning agent.	

	<b>⚠ WARNING</b>
	Rotating Parts can cause severe injury. Stay away while engine is in operation.
Keep hands, feet, hair, and clothing away from all moving parts to prevent injury. Never operate engine with covers, shrouds, or guards removed.	

	<b>⚠ WARNING</b>
	Carbon Monoxide can cause severe nausea, fainting or death. Avoid inhaling exhaust fumes. Never run engine indoors or in enclosed spaces.
Engine exhaust gases contain poisonous carbon monoxide. Carbon monoxide is odorless, colorless, and can cause death if inhaled.	

	<b>⚠ WARNING</b>
	Accidental Starts can cause severe injury or death. Disconnect and ground spark plug lead(s) before servicing.
Before working on engine or equipment, disable engine as follows: 1) Disconnect spark plug lead(s). 2) Disconnect negative (-) battery cable from battery.	

	<b>⚠ WARNING</b>
	Hot Parts can cause severe burns. Do not touch engine while operating or just after stopping.
Never operate engine with heat shields or guards removed.	



	<b>⚠ WARNING</b>
	Cleaning Solvents can cause severe injury or death. Use only in well ventilated areas away from ignition sources.
Carburetor cleaners and solvents are extremely flammable. Follow cleaner manufacturer's warnings and instructions on its proper and safe use. Never use gasoline as a cleaning agent.	

	<b>⚠ CAUTION</b>
	Electrical Shock can cause injury. Do not touch wires while engine is running.

	<b>⚠ CAUTION</b>
	Damaging Crankshaft and Flywheel Can cause personal injury.
Using improper procedures can lead to broken fragments. Broken fragments could be thrown from engine. Always observe and use precautions and procedures when installing flywheel.	

	<b>⚠ CAUTION</b>
	Failure to utilize or reassemble debris screen as designed could result in debris screen failure and serious personal injury.

## MAINTENANCE INSTRUCTIONS

  	<b>⚠ WARNING</b>	Before working on engine or equipment, disable engine as follows: 1) Disconnect spark plug lead(s). 2) Disconnect negative (-) battery cable from battery.
	Accidental Starts can cause severe injury or death. Disconnect and ground spark plug lead(s) before servicing.	

Normal maintenance, replacement or repair of emission control devices and systems may be performed by any repair establishment or individual; however, warranty repairs must be performed by a Rehlko authorized dealer.

## MAINTENANCE SCHEDULE

### Weekly

• Check filter minder.	Air Cleaner/Intake
------------------------	--------------------

### Every 25 Hours or Annually<sup>1</sup>

• Service/replace low-profile precleaner.	Air Cleaner/Intake
-------------------------------------------	--------------------

### Every 100 Hours or Annually<sup>1</sup>

• Change oil. Oil filter is recommended.	Lubrication System
------------------------------------------	--------------------

### Every 150 Hours<sup>1</sup>

• Replace low-profile air cleaner element.	Air Cleaner/Intake
• Remove cooling shrouds and clean cooling areas.	Air Cleaner/Intake

### Every 150 Hours

• Check heavy-duty air cleaner element.	Air Cleaner/Intake
• Replace fuel filter.	
• Check oil cooler fins, clean as necessary.	Lubrication System

### Every 200 Hours

• Change oil filter.	Lubrication System
----------------------	--------------------

### Every 300 Hours

• Replace heavy-duty air cleaner element.	Air Cleaner/Intake
-------------------------------------------	--------------------

### Every 300 Hours<sup>3</sup>

• Change oil and filter (Xtended Life PRO 10W-50 oil and Xtended Life PRO filter only).	Lubrication System
-----------------------------------------------------------------------------------------	--------------------

### Every 500 Hours or Annually<sup>1</sup>

• Replace spark plugs and set gap.	Electrical System
------------------------------------	-------------------

### Every 500 Hours<sup>2</sup>

• Have crankshaft splines lubricated.	
---------------------------------------	--

### Every 600 Hours

• Replace heavy-duty inner air cleaner element.	Air Cleaner/Intake
-------------------------------------------------	--------------------

<sup>1</sup> Perform these procedures more frequently under severe, dusty, dirty conditions.

<sup>2</sup> Have a Rehlko authorized dealer perform this service.

<sup>3</sup> Option only if using Rehlko Xtended Life PRO oil and Xtended Life PRO filter.

## REPAIRS/SERVICE PARTS

Rehlko genuine service parts can be purchased from Rehlko authorized dealers. To find a local Rehlko authorized dealer visit [engines.rehlko.com](http://engines.rehlko.com) or call 1-800-544-2444 (U.S. and Canada).

# Maintenance

## OIL RECOMMENDATIONS

All-season Xtended Life PRO 10W-50 Synthetic Oil is the ideal oil for Rehlko engines. It is specifically formulated to extend the oil and oil filter change interval to 300 Hours when paired with Xtended Life PRO Oil Filter.

300-Hour oil and oil filter change intervals are exclusive to and only authorized on Rehlko engines that utilize both the Xtended Life PRO 10W-50 Synthetic Oil and Xtended Life PRO Oil Filter. Alternative engine oils and oil filters may be used with Rehlko engines but require 100-Hour oil and 200-Hour oil filter change intervals for proper maintenance. Oil must be API (American Petroleum Institute) service class SJ or higher. Select viscosity based on air temperature at time of operation as shown below.

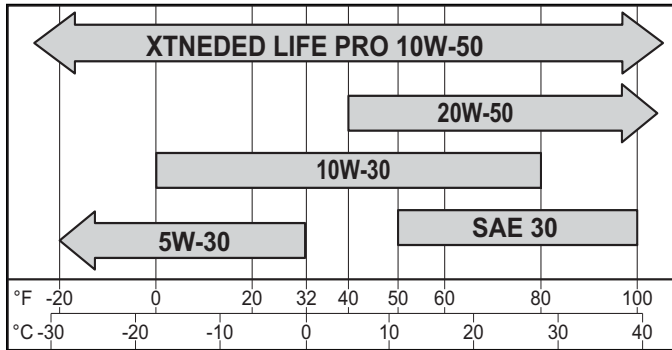

## STORAGE

If engine will be out of service for 2 months or more follow procedure below.

1. Add Xtended Life PRO Series fuel treatment or equivalent to fuel tank. Run engine 2-3 minutes to get stabilized fuel into fuel system (failures due to untreated fuel are not warrantable).
2. Change oil while engine is still warm from operation (NOT required if using Xtended Life PRO 10W-50 full-synthetic oil). Remove spark plug(s) and pour about 1 oz. of engine oil into cylinder(s). Replace spark plug(s) and crank engine slowly to distribute oil.
3. Disconnect negative (-) battery cable.
4. Store engine in a clean, dry place.

## FUEL RECOMMENDATIONS

	<b>WARNING</b>
	Explosive Fuel can cause fires and severe burns. Do not fill fuel tank while engine is hot or running.
Gasoline is extremely flammable and its vapors can explode if ignited. Store gasoline only in approved containers, in well ventilated, unoccupied buildings, away from sparks or flames. Spilled fuel could ignite if it comes in contact with hot parts or sparks from ignition. Never use gasoline as a cleaning agent.	

NOTE: E15, E20 and E85 are NOT approved and should NOT be used; effects of old, stale or contaminated fuel are not warrantable.

Fuel must meet these requirements:

- Clean, fresh, unleaded gasoline.
- Octane rating of 87 (R+M)/2 or higher.
- Research Octane Number (RON) 90 octane minimum.
- Gasoline up to 10% ethyl alcohol, 90% unleaded is acceptable.
- Methyl Tertiary Butyl Ether (MTBE) and unleaded gasoline blend (max 15% MTBE by volume) are approved.
- Do not add oil to gasoline.
- Do not overfill fuel tank.
- Do not use gasoline older than 30 days.

## Engine Dimensions with Heavy-Duty Air Cleaner - Flywheel Side

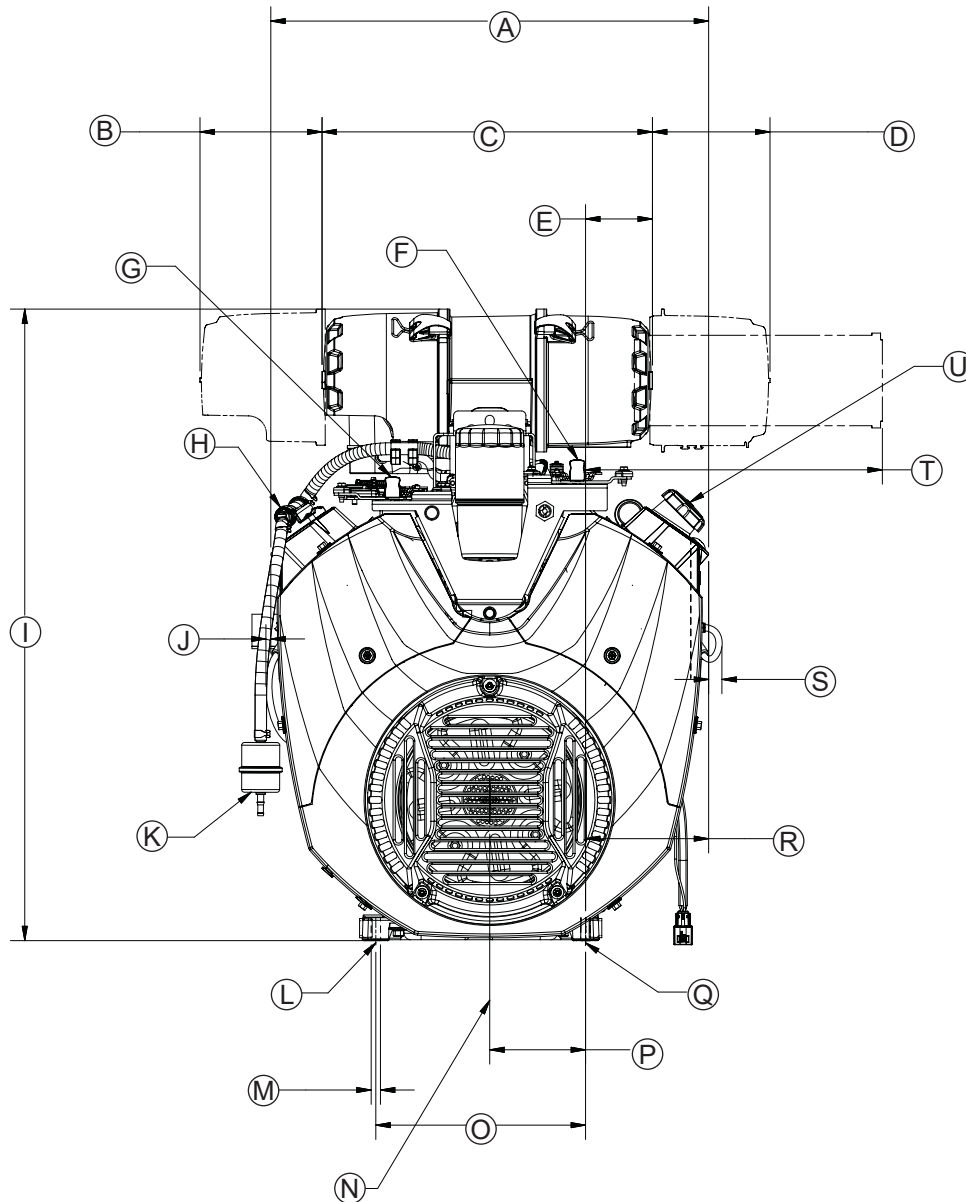

<b>A</b>	484.3 mm (19.07 in.)	<b>B</b>	135.0 mm (5.32 in.) Rain Cap Cover Removal	<b>C</b>	365.5 mm (14.39 in.)	<b>D</b>	130.0 mm (5.12 in.) Air Filter Cover Removal
<b>E</b>	74.0 mm (2.91 in.)	<b>F</b>	Choke Control	<b>G</b>	Throttle Control	<b>H</b>	Mechanical Fuel Pump
<b>I</b>	698.6 mm (27.50 in.)	<b>J</b>	5.4 mm (0.21 in.) Spark Plug Lead	<b>K</b>	Supply Fuel Filter	<b>L</b>	Engine Mounting Surface
<b>M</b>	8 X 10.3 mm (0.40 in.) Thru Mounting Holes	<b>N</b>	Center Line Engine	<b>O</b>	232.0 mm (9.13 in.)	<b>P</b>	106.0 mm (4.17 in.)
<b>Q</b>	Mounting Hole "A"	<b>R</b>	136.2 mm (5.36 in.)	<b>S</b>	14.7 mm (0.58 in.) Spark Plug Lead	<b>T</b>	328.3 mm (12.93 in.) Air Filter Element Removal
<b>U</b>	Oil Fill						

# Specifications

## Engine Dimensions with Heavy-Duty Air Cleaner - PTO Side

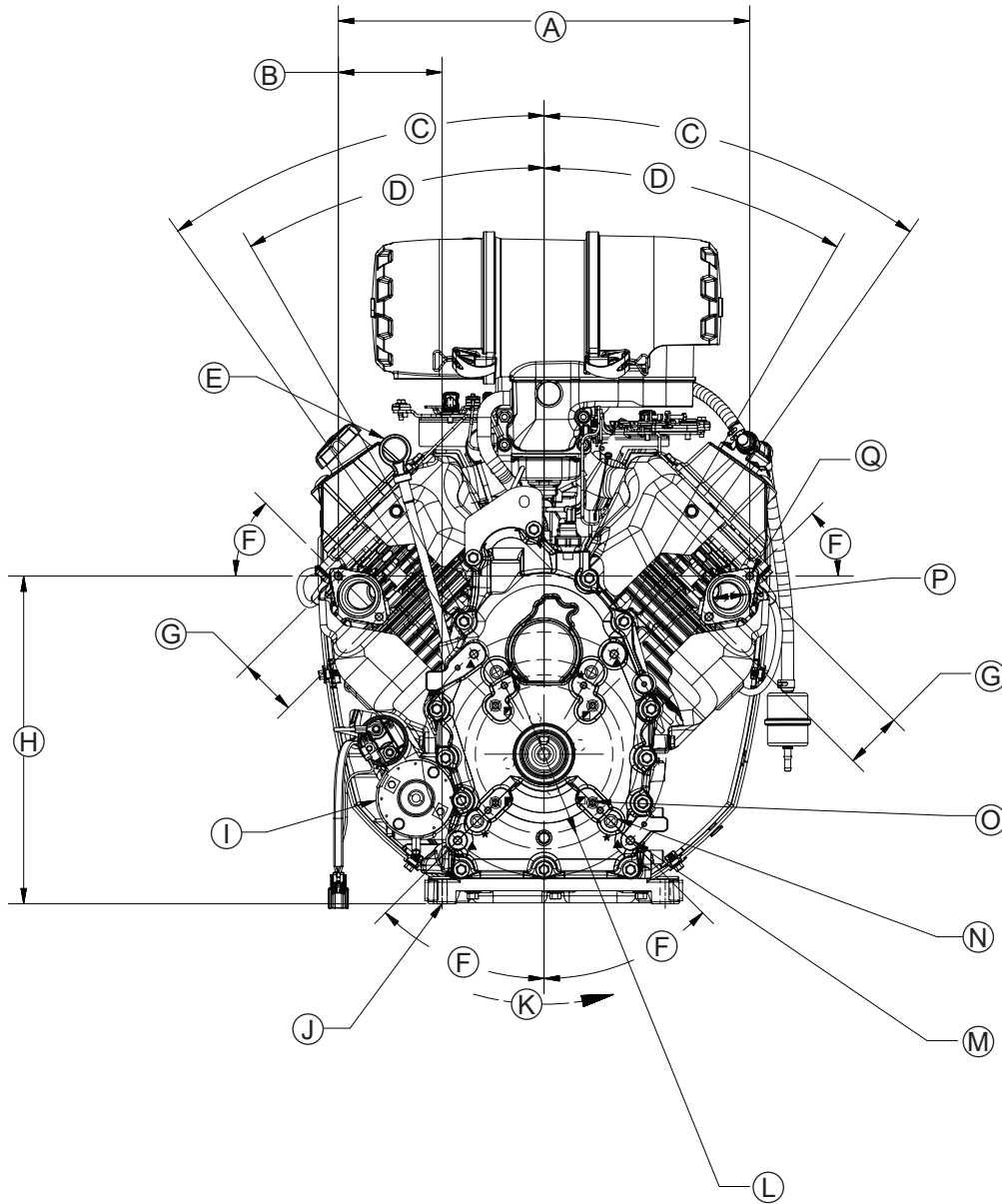

<b>A</b>	427.8 mm (16.84 in.)	<b>B</b>	107.9 mm (4.25 in.)	<b>C</b>	35°	<b>D</b>	30°
<b>E</b>	Oil Level Dipstick	<b>F</b>	45°	<b>G</b>	60.0 mm (2.37 in.) Exhaust Port	<b>H</b>	340.8 mm (13.42 in.)
<b>I</b>	Solenoid Shift Starter	<b>J</b>	Mounting Hole "A"	<b>K</b>	Rotation Direction	<b>L</b>	177.8 mm (7.0 in.) Optional Pilot
<b>M</b>	M8 X 1.25 mm-6H in. 25 mm (0.98 in.) Deep on a Ø 254 mm (10.0 in.) B.C.	<b>N</b>	4 X 7/16-14 UNC-2B in. 21 mm (0.83 in.) Deep on a Ø 196.9 mm (7.750 in.) B.C.	<b>O</b>	4 X 3/8-16 UNC-2B in. 17 mm (0.67 in.) Deep on a Ø 142.9 mm (5.63 in.) B.C.	<b>P</b>	2 X 35.0 mm (1.38 in.) Gasket
<b>Q</b>	4 X M8 X 1.25 mm Studs						

## Engine Dimensions with Heavy-Duty Air Cleaner - Starter Side

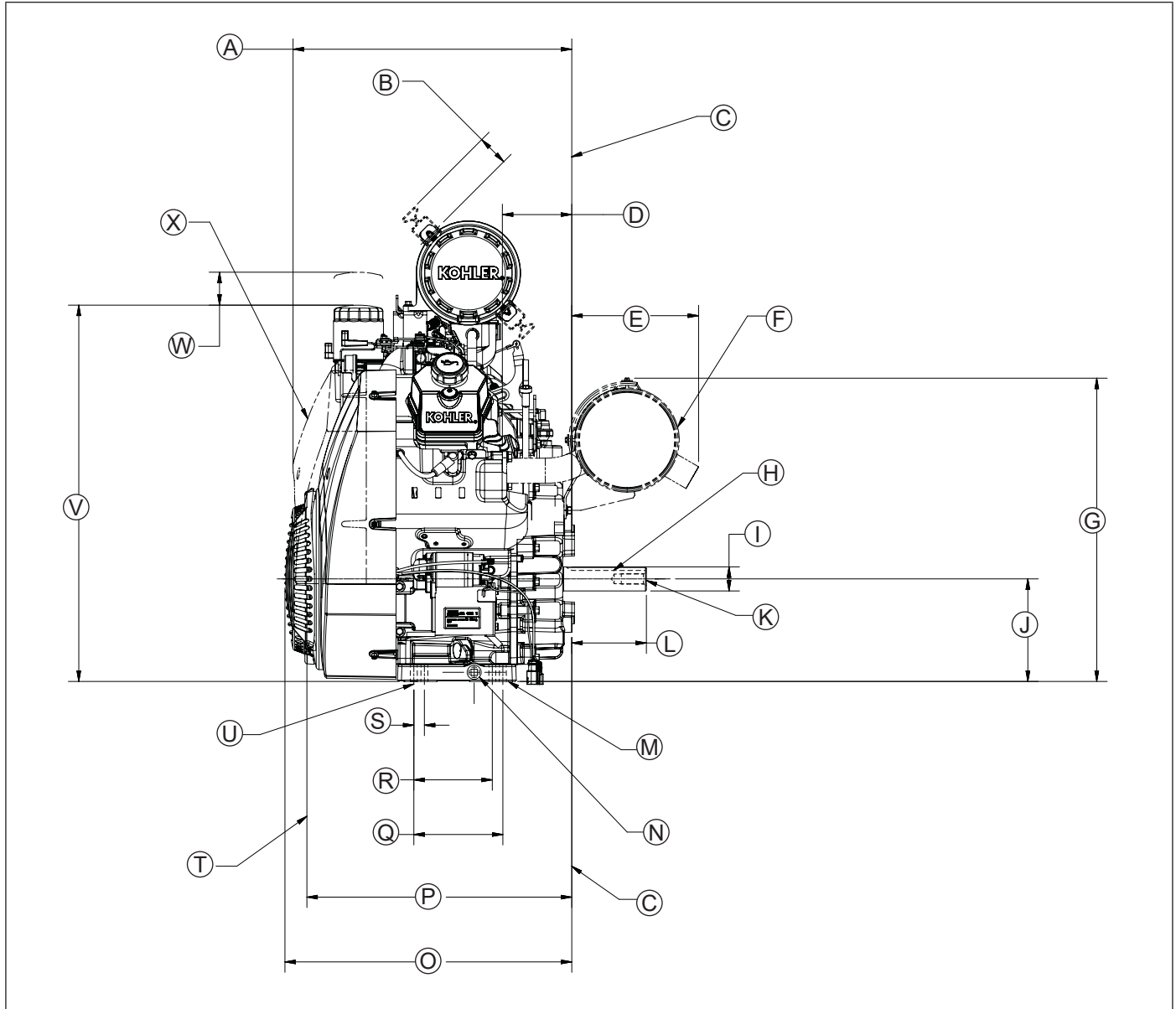

<b>A</b>	422.7 mm (16.64 in.) Cylinder #1 Shroud Removed	<b>B</b>	4 X 47.3 mm (1.86 in.) Air Cleaner Clip Clearance	<b>C</b>	PTO Mounting Surface	<b>D</b>	105.3 mm (4.14 in.) Exhaust Port #1
<b>E</b>	192.3 mm (7.57 in.)	<b>F</b>	Muffler (Optional)	<b>G</b>	460.0 mm (18.11 in.)	<b>H</b>	9.5 mm (0.38 in.) SQ. Keyway
<b>I</b>	36.5 mm (1.44 in.)	<b>J</b>	155.6 mm (6.13 in.)	<b>K</b>	5/8-18 UNF-2B in. 38.1 mm (1.5 in.) Deep	<b>L</b>	113.2 mm (4.46 in.)
<b>M</b>	Engine Mounting Surface	<b>N</b>	Oil Drain Plug 1/2 NPT Inch	<b>O</b>	435.0 mm (17.13 in.)	<b>P</b>	401.8 mm (15.82 in.)
<b>Q</b>	135.0 mm (5.3 in.)	<b>R</b>	119.0 mm (4.69 in.)	<b>S</b>	16.0 mm (0.63 in.)	<b>T</b>	Grass Screen
<b>U</b>	Mounting Hole "A"	<b>V</b>	570.8 mm (22.47 in.)	<b>W</b>	50.0 mm (1.97 in.) Oil Filter Removal	<b>X</b>	Cylinder #1 Shroud

# Specifications

## Engine Dimensions with Heavy-Duty Air Cleaner - Opposite Starter Side

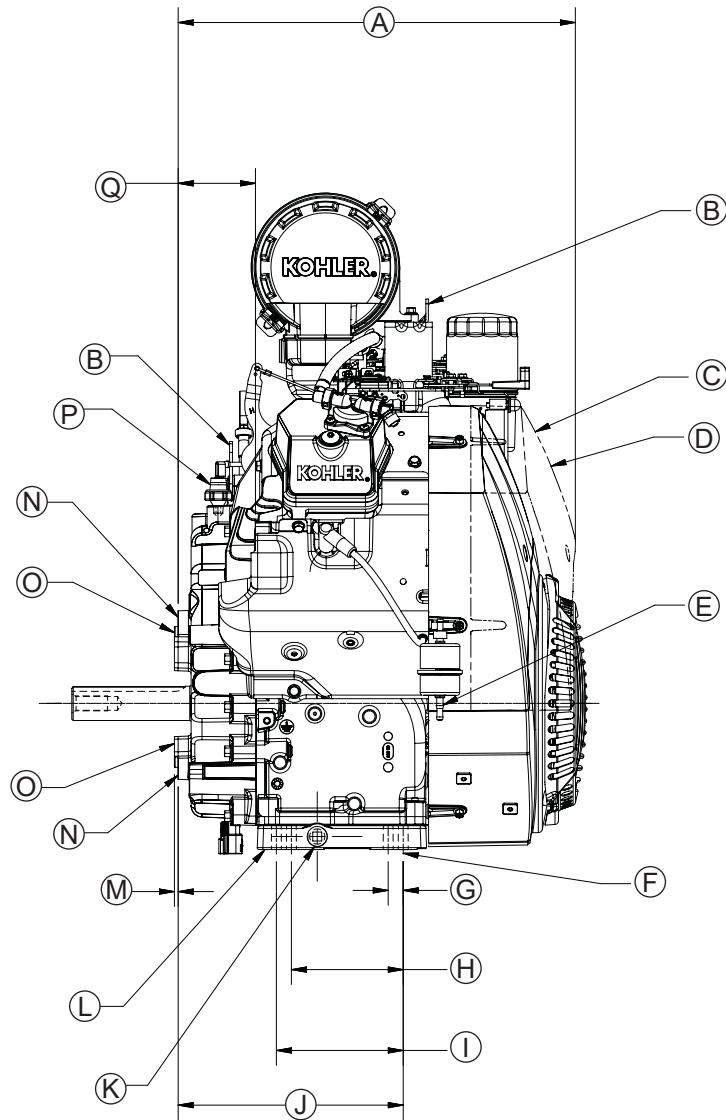

<b>A</b>	422.7 mm (16.64 in.) Cylinder #2 Shroud Removed	<b>B</b>	Lifting Point	<b>C</b>	Cylinder #2 Shroud	<b>D</b>	Access to Oil Cooler
<b>E</b>	Fuel Filter	<b>F</b>	Mounting Hole "A"	<b>G</b>	16.0 mm (0.63 in.)	<b>H</b>	119.0 mm (4.69 in.)
<b>I</b>	135.0 mm (5.32 in.)	<b>J</b>	239.5 mm (9.43 in.)	<b>K</b>	Oil Drain Plug 1/2 NPT Inch	<b>L</b>	Engine Mounting Surface
<b>M</b>	4 X 4.0 mm (0.16 in.) Pilot Height	<b>N</b>	PTO Mounting Surface	<b>O</b>	Pilot Surface	<b>P</b>	Oil Pressure Switch
<b>Q</b>	82.3 mm (3.24 in.) Exhaust Port #2						

## Engine Dimensions - Mounting Surface View

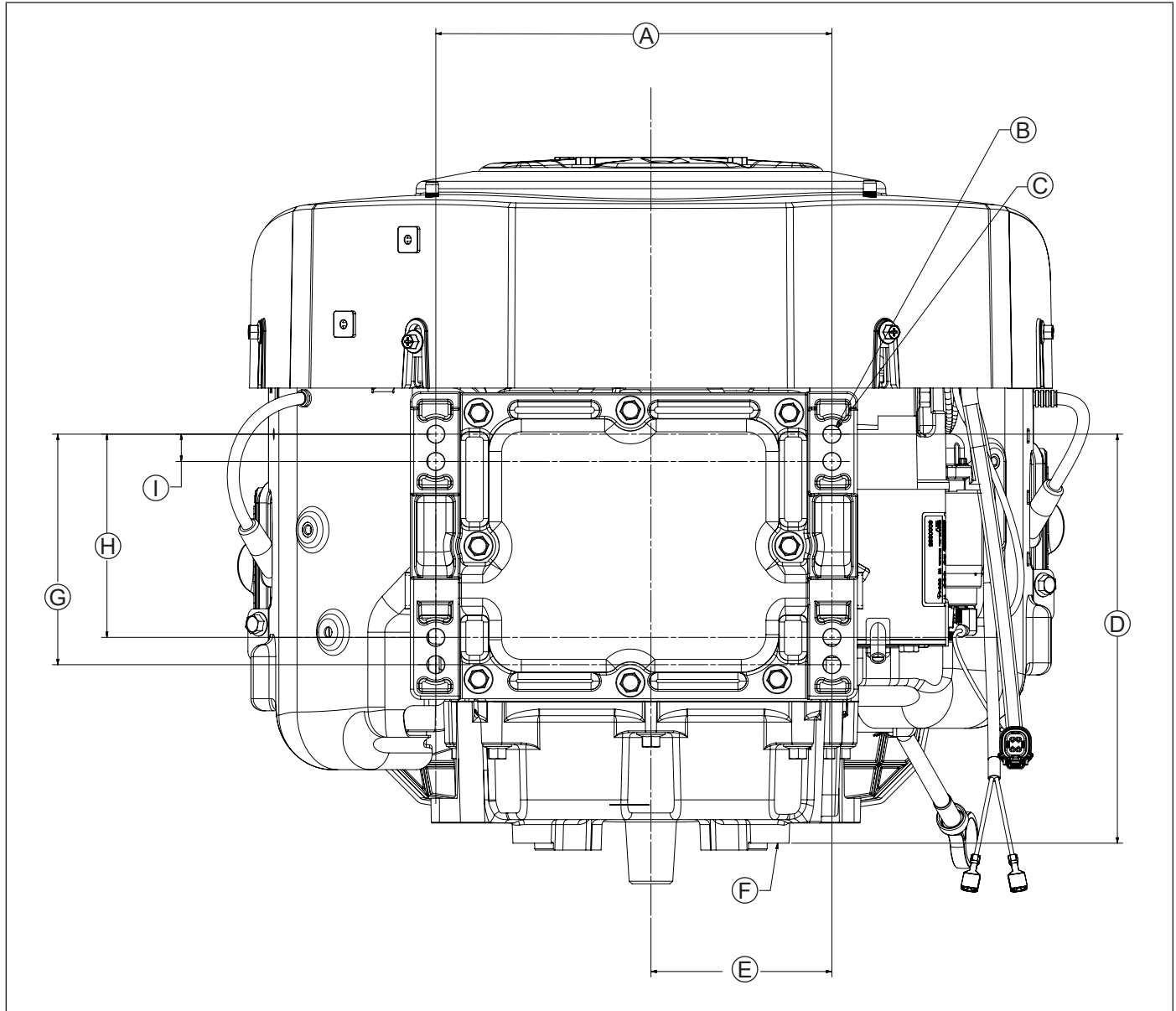

<b>A</b>	232.0 mm (9.13 in.)	<b>B</b>	8 X 10.3 mm (0.40 in.) Thru Mounting Holes	<b>C</b>	Mounting Hole "A"	<b>D</b>	239.5 mm (9.43 in.)
<b>E</b>	106.0 mm (4.17 in.)	<b>F</b>	PTO Mounting Surface	<b>G</b>	135.0 mm (5.32 in.)	<b>H</b>	119.0 mm (4.69 in.)
<b>I</b>	16.0 mm (0.63 in.)						

# Specifications

## Engine Dimensions with Low-Profile Air Cleaner - Flywheel Side

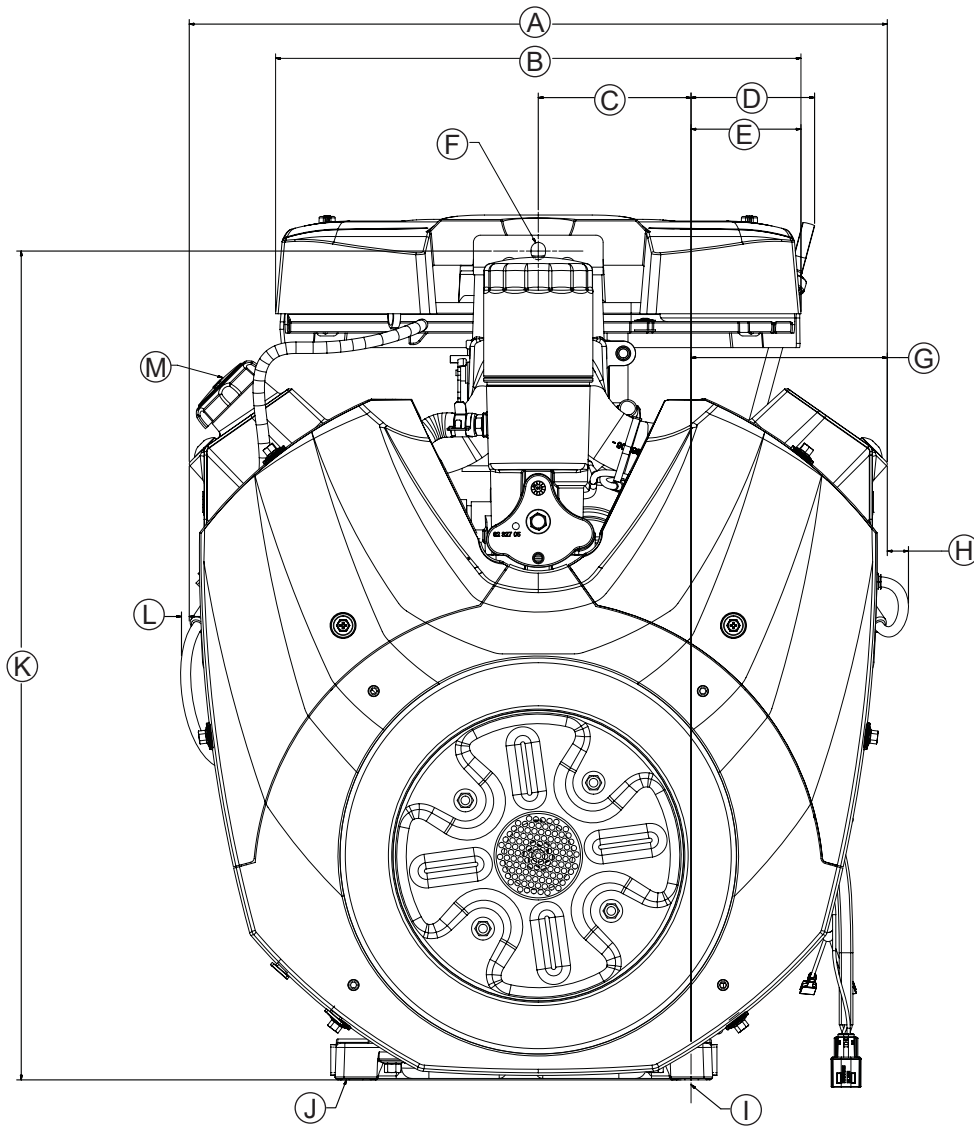

<b>A</b>	484.3 mm (19.07 in.)	<b>B</b>	364.5 mm (14.35 in.)	<b>C</b>	106.0 mm (4.17 in.) Lifting Point	<b>D</b>	85.7 mm (3.38 in.)
<b>E</b>	76.3 mm (3.00 in.)	<b>F</b>	Lifting Point 10 X 12 mm (0.39 X 0.47 in.) Slot	<b>G</b>	136.2 mm (5.36 in.)	<b>H</b>	14.7 mm (0.58 in.) Spark Plug Lead
<b>I</b>	Mounting Hole "A"	<b>J</b>	Engine Mounting Surface	<b>K</b>	575.1 mm (22.64 in.) Lifting Point	<b>L</b>	5.4 mm (0.21 in.) Spark Plug Lead
<b>M</b>	Oil Fill						

## Engine Dimensions with Low-Profile Air Cleaner - PTO Side

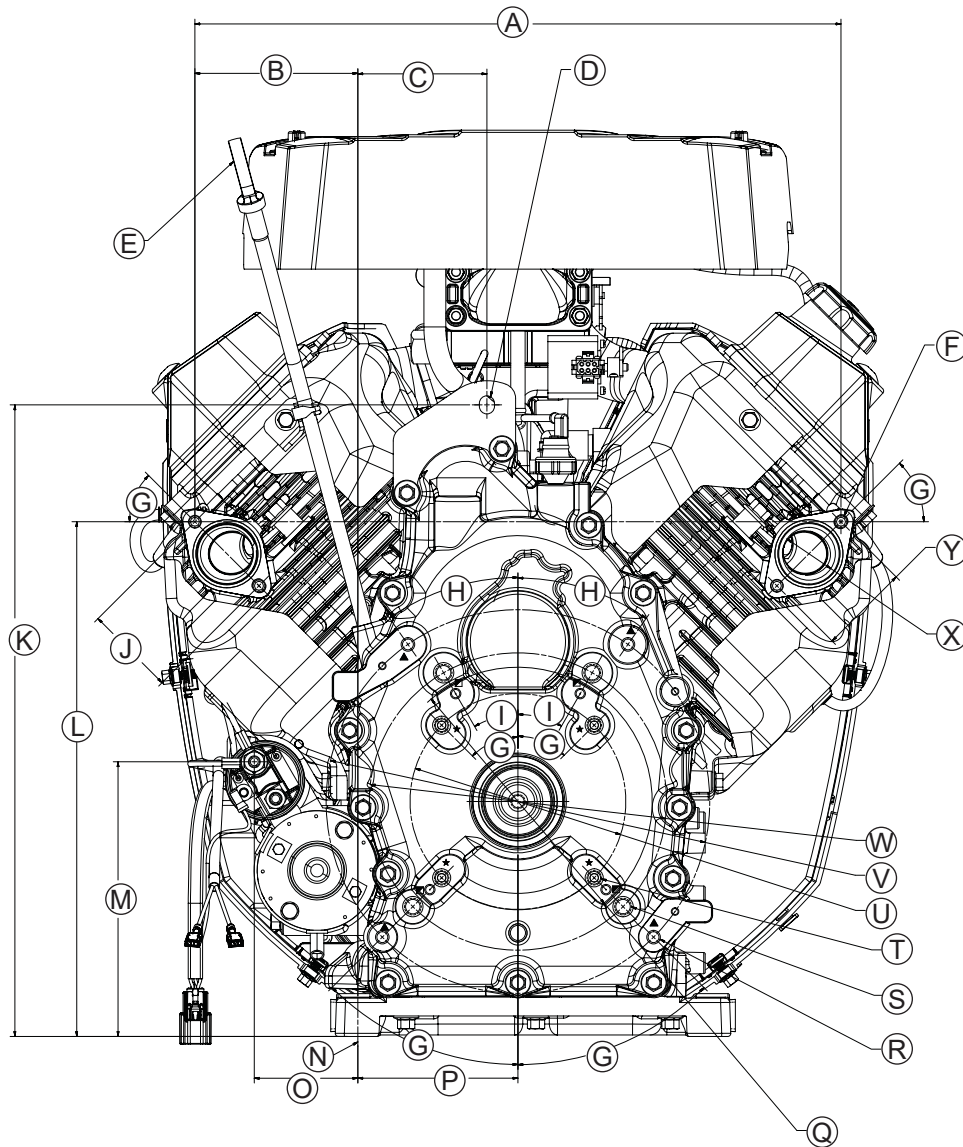

<b>A</b>	427.8 mm (18.84 in.)	<b>B</b>	107.9 mm (4.25 in.)	<b>C</b>	85.5 mm (3.37 in.) Lifting Point	<b>D</b>	Lifting Point 10 X 12 mm (0.39 X 0.47 in.) Slot
<b>E</b>	Oil Level Dipstick	<b>F</b>	M8 X 1.25 mm Studs	<b>G</b>	45°	<b>H</b>	35°
<b>I</b>	30°	<b>J</b>	60.0 mm (2.37 in.) Exhaust Port #1	<b>K</b>	481.2 mm (16.47 in.) Lifting Point	<b>L</b>	340.8 mm (13.42 in.)
<b>M</b>	181.9 mm (7.16 in.) Starter Stud	<b>N</b>	Mounting Hole "A"	<b>O</b>	68.6 mm (2.70 in.) Starter Stud	<b>P</b>	106.0 mm (4.17 in.)
<b>Q</b>	177.8 mm (7.01 in.) Pilot	<b>R</b>	M8 X 1.25 mm-6H in. 25 mm (0.98 in.) Deep on a Ø 254 mm (10.0 in.) B.C.	<b>S</b>	4 X 7/16-14 UNC-2B in. 21 mm (0.83 in.) Deep on a Ø 196.88 mm (7.750 in.) B.C.	<b>T</b>	4 X 3/8-16 UNC-2B in. 17 mm (0.67 in.) Deep on a Ø 142.88 mm (5.625 in.) B.C.
<b>U</b>	142.9 mm (5.63 in.)	<b>V</b>	254.0 mm (10 in.)	<b>W</b>	196.9 mm (7.75 in.)	<b>X</b>	2 X 35.0 mm (1.38 in.) Gasket
<b>Y</b>	60.0 mm (2.36 in.) Exhaust Port #2						

# Specifications

## Engine Dimensions with Low-Profile Air Cleaner - Starter Side

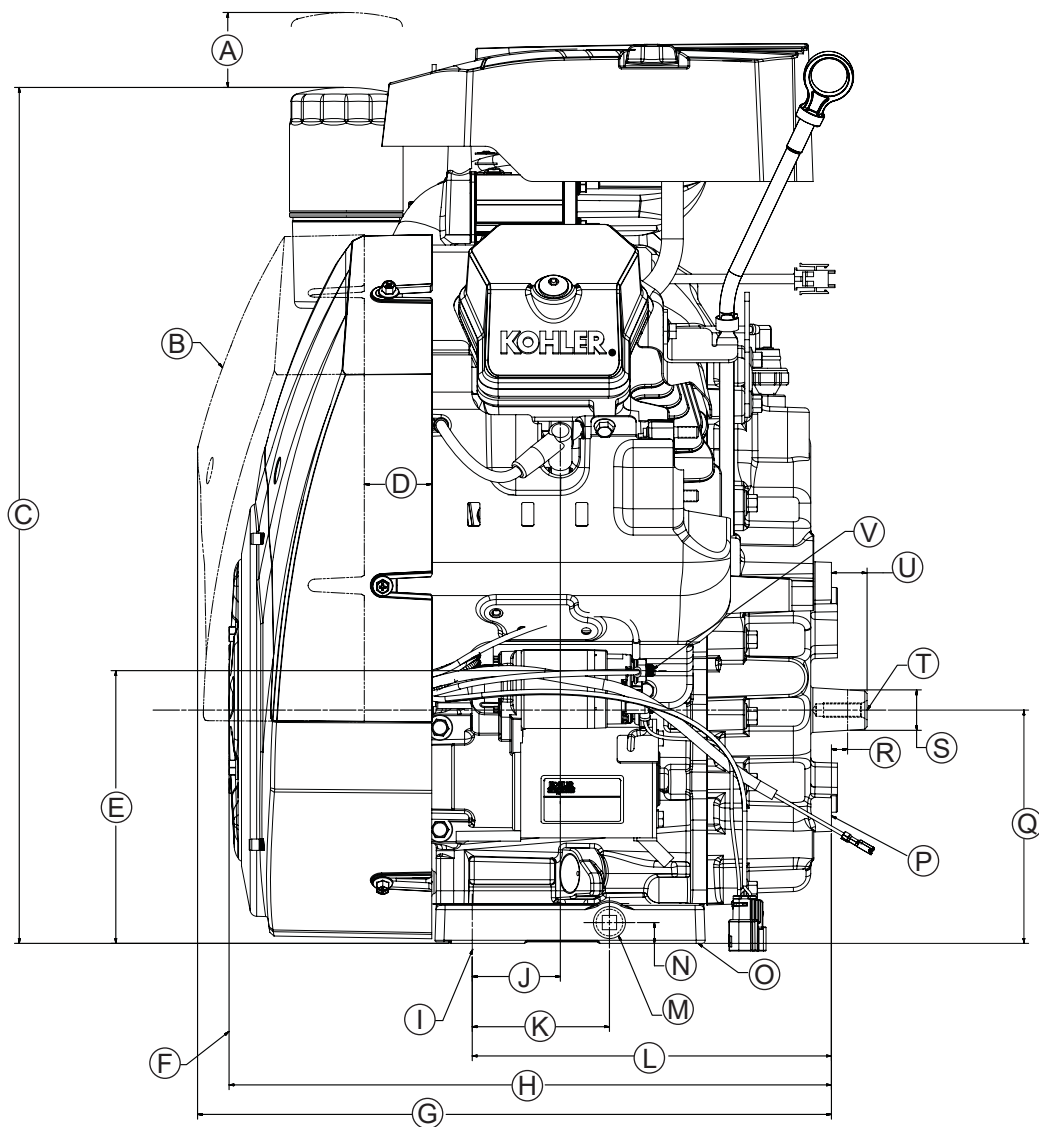

<b>A</b>	50.0 mm (1.97 in.) Oil Filter Removal	<b>B</b>	Cylinder #1 Shroud	<b>C</b>	570.8 mm (22.47 in.)	<b>D</b>	45.0 mm (1.77 in.) Cylinder #1 Shroud Removal
<b>E</b>	181.9 mm (7.16 in.) Starter Stud	<b>F</b>	Grass Screen	<b>G</b>	422.7 mm (16.64 in.) Cylinder #1 Shroud Removal	<b>H</b>	401.7 mm (15.82 in.)
<b>I</b>	Mounting Hole "A"	<b>J</b>	58.8 mm (2.31 in.) Spark Plug	<b>K</b>	91.5 mm (3.6 in.)	<b>L</b>	239.5 mm (9.43 in.)
<b>M</b>	Oil Drain Plug 1/2 NPT Inch	<b>N</b>	13.9 mm (0.55 in.)	<b>O</b>	Engine Mounting Surface	<b>P</b>	PTO Mounting Surface
<b>Q</b>	155.6 mm (6.13 in.)	<b>R</b>	10.8 mm (0.42 in.)	<b>S</b>	28.98 mm (1.06 in.)	<b>T</b>	3/8-16 UNC-2B in. 29.0 mm (1.14 in.) Deep
<b>U</b>	23.8 mm (0.94 in.)	<b>V</b>	Starter Stud				

## Engine Dimensions with Low-Profile Air Cleaner - Opposite Starter Side

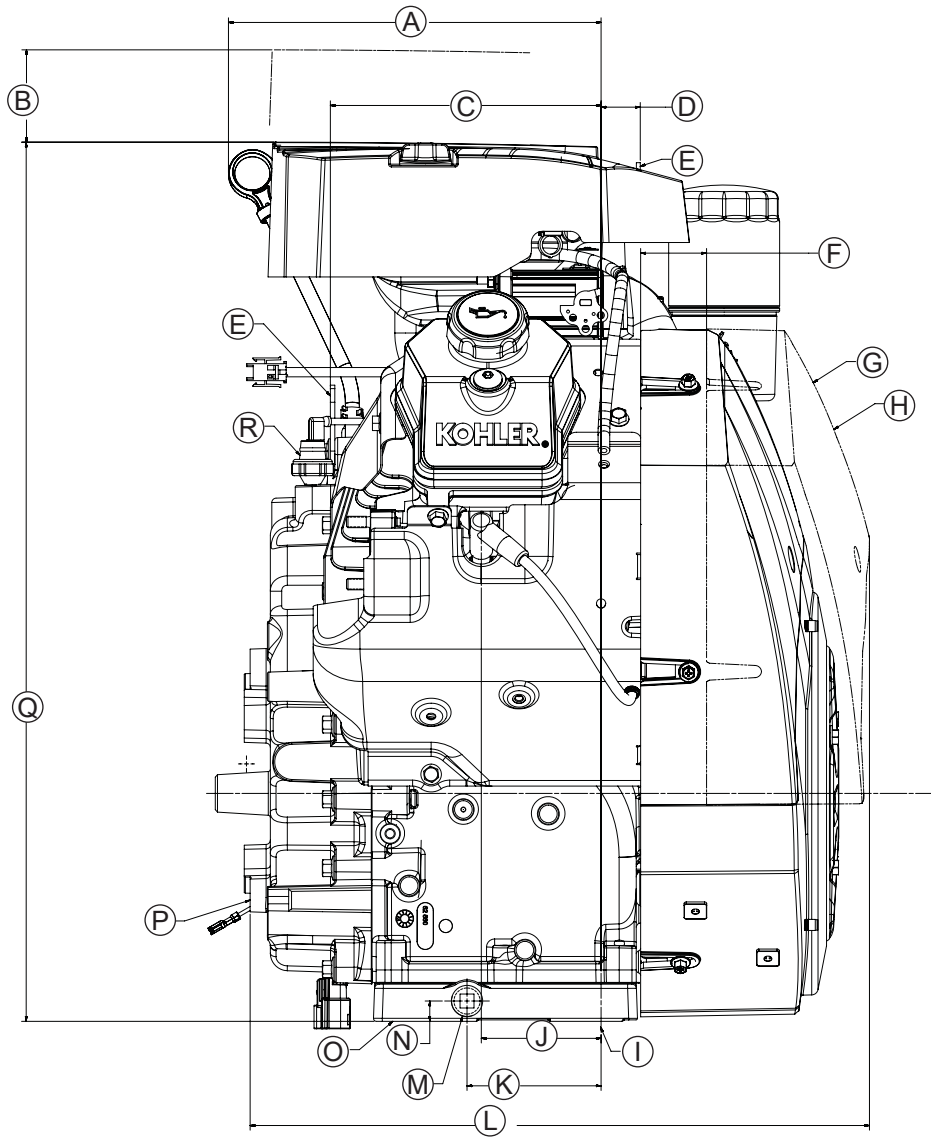

<b>A</b>	254.3 mm (10.01 in.)	<b>B</b>	63.0 mm (2.48 in.) Air Cleaner Cover Removal	<b>C</b>	184.8 mm (7.28 in.)	<b>D</b>	26.7 mm (1.05 in.)
<b>E</b>	Lifting Point	<b>F</b>	45.0 mm (1.77 in.) Cylinder #2 Shroud Removal	<b>G</b>	Cylinder #2 Shroud	<b>H</b>	Access to Oil Cooler
<b>I</b>	Mounting Hole "A"	<b>J</b>	81.8 mm (3.22 in.) Spark Plug	<b>K</b>	91.5 mm (3.60 in.)	<b>L</b>	422.7 mm (16.64 in.) Cylinder #2 Shroud Removal
<b>M</b>	Oil Drain Plug 1/2 NPT Inch	<b>N</b>	13.8 mm (0.55 in.)	<b>O</b>	Engine Mounting Surface	<b>P</b>	PTO Mounting Surface
<b>Q</b>	600.1 mm (23.63 in.)	<b>R</b>	Oil Pressure Switch				

# Specifications

## ENGINE IDENTIFICATION NUMBERS

Rehiko engine identification numbers (model, specification, and serial) should be referenced for efficient repair, ordering correct parts, and engine replacement.

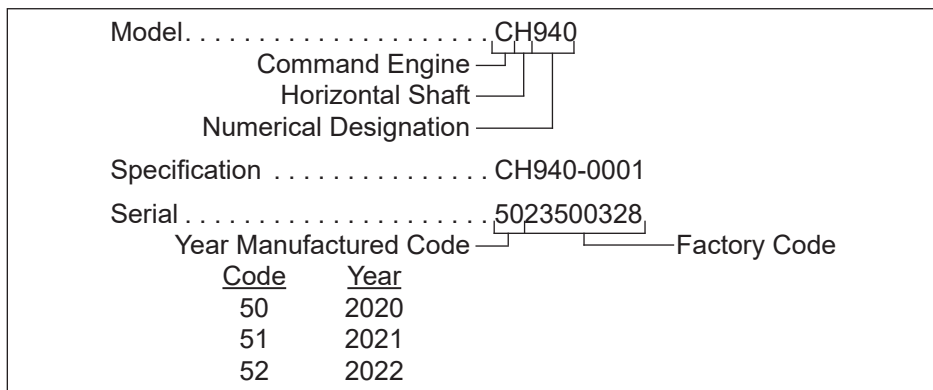

## GENERAL SPECIFICATIONS<sup>4,7</sup>

	CH940	CH960	CH980	CH1000
Bore	90 mm (3.54 in.)			
Stroke	78.5 mm (3.1 in.)			
Displacement	999 cc (61 cu. in.)			
Oil Capacity (refill)	1.9-2.6 L (2.0-2.7 U.S. qt.)			
Maximum Angle of Operation (@ full oil level) <sup>5</sup>	25°			

## TORQUE SPECIFICATIONS<sup>4,6</sup>

	CH940	CH960	CH980	CH1000
<b>Blower Housing and Sheet Metal</b>				
M6 Screw				
New, Untapped Hole (casting)	10.7 N·m (95 in. lb.)			
Used, Tapped Hole (casting)	7.3 N·m (65 in. lb.)			
New, Extruded Hole (sheet metal)	2.5 N·m (22 in. lb.)			
Used, Extruded Hole (sheet metal)	2.0 N·m (18 in. lb.)			
Mounting Clip (valley baffle)	2.5 N·m (22 in. lb.)			
<b>Carburetor, Intake Manifold, and Air Cleaner</b>				
Intake Manifold Mounting Fastener (torque in 2 increments)	first to 16.9 N·m (150 in. lb.) finally to 22.6 N·m (200 in. lb.)			
Carburetor/Air Cleaner Mounting Nut	11.3 N·m (100 in. lb.)			
Carburetor Fuel Bowl Screw	2.5 N·m (22 in. lb.) ± 0.3 N·m (3 in. lb.)			
Air Cleaner Mounting Screw (into intake manifold)	11.3 N·m (100 in. lb.)			
<b>Closure Plate</b>				
Closure Plate Fastener	25.6 N·m (227 in. lb.)			
<b>Connecting Rod</b>				
Cap Fastener (torque in increments)	11.6 N·m (103 in. lb.)			
<b>Control Bracket</b>				
Mounting Screw (into intake manifold from air cleaner)	10.2 N·m (90 in. lb.)			

<sup>4</sup> Values are in Metric units. Values in parentheses are English equivalents.

<sup>5</sup> Exceeding maximum angle of operation may cause engine damage from insufficient lubrication.

<sup>6</sup> Lubricate threads with engine oil prior to assembly.

<sup>7</sup> Any and all horsepower (hp) reference by Rehiko are Certified Power Ratings and per SAE J1940 & J1995 hp standards. Details on Certified Power Ratings can be found at [engines.rehiko.com](http://engines.rehiko.com).

## TORQUE SPECIFICATIONS<sup>4,6</sup>

**CH940**
**CH960**
**CH980**
**CH1000**

### Control Panel

M6 screw	11.3 N·m (100 in. lb.) into new holes 7.7 N·m (69 in. lb.) into used holes
M5 screws	6.5 N·m (58 in. lb.) into new holes 4.1 N·m (37 in. lb.) into used holes

### Crankcase

Breather Cover Fastener	12.4 N·m (110 in. lb.)
Oil Drain Plug	21.4 N·m (16 ft. lb.)

### Cylinder Head

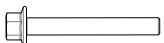
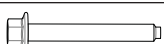
Cylinder Head Fastener (torque in 2 increments) Head Bolt	first to 23.7 N·m (210 in. lb.) finally to 46.9 N·m (415 in. lb.)
Pipe Plug (3/4 in.)	28.5 N·m (252 in. lb.)
Rocker Arm Screw	
	15.5 N·m (137 in. lb.)
	11.9 N·m (105 in. lb.)

### Debris Screen

Fastener	9.9 N·m (88 in. lb.)
Hex Stud	21.5 N·m (190 in. lb.)
Mounting Screw - Hex Flange Screw	20.3 N·m (180 in. lb.)
Mounting Screw - Button Head Cap Screw	9.9 N·m (88 in. lb.)
Front Drive Shaft Screw (into flywheel)	24.4 N·m (216 in. lb.)

### Fan/Flywheel

Fan Fastener Screw - Truss Head	10.4 N·m (92 in. lb.)
Fan Fastener Screw - Hex Head	9.9 N·m (88 in. lb.)
Flywheel Retaining Screw	69.8 N·m (51 ft. lb.)

### Governor

Governor Lever Nut	7.1 N·m (63 in. lb.)
Governor Yoke Mounting Screw	2.2 N·m (20 in. lb.)

### Ignition

Spark Plug	27 N·m (20 ft. lb.)
Ignition Module Fastener	9.7 N·m (86 in. lb.) into new holes 4.1 N·m (37 in. lb.) into used holes
Rectifier-Regulator Fastener	2.5 N·m (22 in. lb.)

### Lifter Feed Chamber

Cover/Baffle Screw	7.7 N·m (68 in. lb.)
--------------------	----------------------

### Muffler

Retaining Nut	24.4 N·m (216 in. lb.)
M6 Screw	9.9 N·m (88 in. lb.)
M8 Screw	24.4 N·m (216 in. lb.)

<sup>4</sup> Values are in Metric units. Values in parentheses are English equivalents.

<sup>6</sup> Lubricate threads with engine oil prior to assembly.

# Specifications

## TORQUE SPECIFICATIONS<sup>4,6</sup>

**CH940      CH960      CH980      CH1000**

### Oil Cooler

Mounting Screws	2.3 N·m (21 in. lb.)
-----------------	----------------------

### Oil Filter Adapter/Housing

Adapter/Housing Mounting Screw	23.7 N·m (210 in. lb.)
--------------------------------	------------------------

Oil Filter Nipple	17.8 N·m (158 in. lb.)
-------------------	------------------------

### Oil Pickup Screen

Mounting Screw	9.3 N·m (82 in. lb.) into new holes 7.7 N·m (68 in. lb.) into used holes
----------------	-----------------------------------------------------------------------------

### Oil Pickup Tube

Mounting Screw	11.3 N·m (100 in. lb.) into new holes 7.7 N·m (68 in. lb.) into used holes
----------------	-------------------------------------------------------------------------------

### Oil Pump

Mounting Screw	9.9 N·m (88 in. lb.)
----------------	----------------------

### Oil Sentry™

Pressure Switch	10.7 N·m (95 in. lb.)
-----------------	-----------------------

### Reservoir (oil)

Mounting Screw	25.6 N·m (227 in. lb.)
----------------	------------------------

### Solenoid (starter)

Mounting Hardware	4.0-6.0 N·m (35-53 in. lb.)
-------------------	-----------------------------

Nut, Positive (+) Brush Lead	8.0-11.0 N·m (71-97 in. lb.)
------------------------------	------------------------------

### Starter Assembly

Thru Bolt	5.6-9.0 N·m (49-79 in. lb.)
-----------	-----------------------------

Mounting Screw	16.0 N·m (142 in. lb.)
----------------	------------------------

Brush Holder Mounting Screw	2.5-3.3 N·m (22-29 in. lb.)
-----------------------------	-----------------------------

### Stator

Mounting Screw	9.3 N·m (82 in. lb.)
----------------	----------------------

### Throttle/Choke Control Bracket

Fastener	10.2 N·m (90 in. lb.)
----------	-----------------------

### Valve Cover

Aluminum Valve Cover Fastener Into New Head	Torque screw to 26 N·m (230 in. lb.) to ensure seal seats in valve cover groove. Back off screw to zero and then torque screw again to 18.1 N·m (160 in. lb.).
------------------------------------------------	----------------------------------------------------------------------------------------------------------------------------------------------------------------

Into Used Head	Torque screw to 16.4 N·m (145 in. lb.) to ensure seal seats in valve cover groove. Back off screw to zero and then torque screw again to 16.4 N·m (145 in. lb.).
----------------	------------------------------------------------------------------------------------------------------------------------------------------------------------------

Plastic Valve Cover Fastener	13.6 N·m (120 in. lb.)
------------------------------	------------------------

<sup>4</sup> Values are in Metric units. Values in parentheses are English equivalents.

<sup>6</sup> Lubricate threads with engine oil prior to assembly.

# Specifications

## CLEARANCE SPECIFICATIONS<sup>4</sup>

**CH940**
**CH960**
**CH980**
**CH1000**

### Camshaft

End Play	0.3/1.3 mm (0.011/0.051 in.)	
Running Clearance	0.025/0.063 mm (0.0010/0.0025 in.)	
Bore I.D. New Max. Wear Limit	20.000/20.025 mm (0.7874/0.7884 in.) 20.038 mm (0.7889 in.)	
Bearing Surface O.D. New Max. Wear Limit	19.962/19.975 mm (0.7859/0.7864 in.) 19.959 mm (0.7858 in.)	
Cam Lobe Profile (minimum dimension, measured from base circle to top of lobe) Exhaust	35 mm (1.3779 in.)	
Intake	34.1 mm (1.3425 in.)	35 mm (1.3779 in.)

### Connecting Rod

Crankpin End I.D. @ 70°F New Max. Wear Limit	44.030/44.037 mm (1.7334/1.7337 in.) 0.070 mm (0.0028 in.)	
Connecting Rod-to-Crankpin Running Clearance New Max. Wear Limit	0.030/0.055 mm (0.0012/0.0022 in.) 0.070 mm (0.0028 in.)	
Connecting Rod-to-Crankpin Side Clearance	0.30/0.59 mm (0.0118/0.0232 in.)	
Connecting Rod-to-Piston Pin Running Clearance	0.015/0.028 mm (0.0006/0.0011 in.)	
Piston Pin End I.D. @ 70°F New Max. Wear Limit	19.023/19.015 mm (0.7489/0.7486 in.) 19.036 mm (0.7494 in.)	

### Crankcase

Governor Cross Shaft Bore I.D. New Max. Wear Limit	8.025/8.050 mm (0.3159/0.3169 in.) 8.088 mm (0.3184 in.)	
----------------------------------------------------------	-------------------------------------------------------------	--

### Crankshaft

End Play (free) Thrust Bearing (Flange) Non-Thrust Bearing	0.30/1.50 mm (0.011/0.059 in.) 0.20/0.94 mm (0.008/0.037 in.)	
Crankshaft Bore (in crankcase) New, Without Main Bearing With Main Bearing Installed Max. Wear Limit	50.00/50.025 mm (1.9685/1.969 in.) 45.040/45.145 mm (1.7732/1.7773 in.) 45.158 mm (1.7778 in.)	
Crankshaft to Sleeve Bearing (in crankcase) Running Clearance New	0.040/0.167 mm (0.0015/0.0065 in.)	
Crankshaft Bore (in closure plate) New, Without Bearing	50.025/50.00 mm (1.9694/1.9685 in.)	
Crankshaft to Sleeve Bearing (in closure plate) Running Clearance New	0.040/0.167 mm (0.0015/0.0065 in.)	
Closure Plate End Main Bearing Journal O.D. - New O.D. - Max. Wear Limit Max. Taper Max. Out-of-Round	44.978/45.00 mm (1.770/1.771 in.) 44.90 mm (1.767 in.) 0.022 mm (0.0009 in.) 0.025 mm (0.0010 in.)	

<sup>4</sup> Values are in Metric units. Values in parentheses are English equivalents.

# Specifications

## CLEARANCE SPECIFICATIONS<sup>4</sup>

**CH940**
**CH960**
**CH980**
**CH1000**

### Crankshaft (continued)

Connecting Rod Journal O.D. - New O.D. - Max. Wear Limit Max. Taper Max. Out-of-Round Width	43.982/44.000 mm (1.731/1.732 in.) 43.97 mm (1.731 in.) 0.018 mm (0.0007 in.) 0.025 mm (0.0010 in.) 53.00/53.09 mm (2.0866/2.0901 in.)
Crankshaft T.I.R. PTO End, Crank in Engine Entire Crank, in V-Blocks	0.279 mm (0.0110 in.) 0.10 mm (0.0039 in.)
Flywheel End Main Bearing Journal O.D. - New O.D. - Max. Wear Limit Max. Taper Max. Out-of-Round	44.978/45.00 mm (1.770/1.771 in.) 44.90 mm (1.767 in.) 0.022 mm (0.0009 in.) 0.025 mm (0.0010 in.)

### Cylinder Bore

Cylinder Bore I.D. New Max. Wear Limit Max. Taper Max. Out-of-Round	90.000/90.025 mm (3.543/3.544 in.) 90.075 mm (3.546 in.) 0.013 mm (0.00051 in.) 0.013 mm (0.00051 in.)
---------------------------------------------------------------------------------	-----------------------------------------------------------------------------------------------------------------

### Cylinder Head

Max. Out-of-Flatness	0.076 mm (0.003 in.)
----------------------	----------------------

### Governor

Governor Cross Shaft-to-Crankcase Running Clearance	0.025/0.087 mm (0.0009/0.0034 in.)
Governor Cross Shaft O.D. New Max. Wear Limit	7.963/8.000 mm (0.3135/0.3149 in.) 7.936 mm (0.3124 in.)
Governor Gear Shaft-to-Governor Gear Running Clearance	0.070/0.160 mm (0.0027/0.0063 in.)
Governor Gear Shaft O.D. New Max. Wear Limit	5.990/6.000 mm (0.2358/0.2362 in.) 5.977 mm (0.2353 in.)

### Ignition

Spark Plug Gap	0.76 mm (0.030 in.)
Ignition Module Air Gap (CDI/MDI Ignition Module)	0.28/0.33 mm (0.011/0.013 in.)



### Crankshaft Bearing (flywheel/PTO)

New (installed) Max. Wear Limit	45.040/45.145 mm (1.773/1.777 in.) 45.158 mm
------------------------------------	-------------------------------------------------

<sup>4</sup> Values are in Metric units. Values in parentheses are English equivalents.

## CLEARANCE SPECIFICATIONS<sup>4</sup>

**CH940**
**CH960**
**CH980**
**CH1000**
**Piston, Piston Rings, and Piston Pin**

Piston Style A 	
Piston-to-Piston Pin Running Clearance	0.006/0.018 mm (0.0002/0.0007 in.)
Piston Pin Bore I.D. New Max. Wear Limit	19.006/19.013 mm (0.7482/0.7485 in.) 19.025 mm (0.7490 in.)
Piston Pin O.D. New Max. Wear Limit	18.995/19.000 mm (0.7478/0.7480 in.) 18.994 mm (0.7478 in.)
Top Compression Ring-to-Groove Side Clearance	0.04/0.08 mm (0.0015/0.0031 in.)
Middle Compression Ring-to-Groove Side Clearance	0.04/0.08 mm (0.0015/0.0031 in.)
Oil Control Ring-to-Groove Side Clearance	0.03/0.19 mm (0.0011/0.0074 in.)
Top and Middle Compression Ring End Gap New Max. Wear Limit	0.30/0.55 mm (0.011/0.021 in.) 0.94 mm (0.037 in.)
Piston Thrust Face O.D. <sup>8</sup> New Bore Used Bore (max.)	89.953/89.967 mm (3.5414/3.5420 in.) 89.925 mm (3.540 in.)
Piston Thrust Face-to-Cylinder Bore <sup>8</sup> Running Clearance New	0.033/0.72 mm (0.0013/0.0028 in.)
Piston Style B 	
Piston-to-Piston Pin Running Clearance	0.006/0.017 mm (0.0002/0.0007 in.)
Piston Pin Bore I.D. New Max. Wear Limit	20.006/20.012 mm (0.7876/0.7879 in.) 20.025 mm (0.7884 in.)
Piston Pin O.D. New Max. Wear Limit	19.995/20.000 mm (0.7872/0.7874 in.) 19.994 mm (0.7872 in.)
Top Compression Ring-to-Groove Side Clearance	0.030/0.070 mm (0.001/0.0026 in.)
Middle Compression Ring-to-Groove Side Clearance	0.030/0.070 mm (0.001/0.0026 in.)
Oil Control Ring-to-Groove Side Clearance	0.060/0.190 mm (0.0022/0.0073 in.)
Top Compression Ring End Gap New Max. Wear Limit	0.125/0.304 mm (0.0049/0.0120 in.) 0.515 mm (0.0203 in.)
Middle Compression Ring End Gap New Max. Wear Limit	0.900/1.179 mm (0.0354/0.0464 in.) 1.432 mm (0.0564 in.)
Piston Thrust Face O.D. <sup>8</sup> New Bore Used Bore (max.)	89.972 mm (3.5422 in.) 89.827 mm (3.5365 in.)
Piston Thrust Face-to-Cylinder Bore <sup>8</sup> Running Clearance New	0.021/0.060 mm (0.0008/0.00236 in.)

<sup>4</sup> Values are in Metric units. Values in parentheses are English equivalents.

<sup>8</sup> Measure 11 mm (0.4331 in.) above bottom of piston skirt at right angles to piston pin.

# Specifications

## CLEARANCE SPECIFICATIONS<sup>4</sup>

**CH940**

**CH960**

**CH980**



**CH1000**

### Valves and Valve Lifters





Hydraulic Valve Lifter to Crankcase Running Clearance	0.012/0.050 mm (0.0004/0.0019 in.)
Intake Valve Stem-to-Valve Guide Running Clearance	0.038/0.076 mm (0.0015/0.0030 in.)
Exhaust Valve Stem-to-Valve Guide Running Clearance	0.050/0.088 mm (0.0020/0.0035 in.)
Intake Valve Guide I.D. New Max. Wear Limit	7.038/7.058 mm (0.2771/0.2779 in.) 7.135 mm (0.2809 in.)
Exhaust Valve Guide I.D. New Max. Wear Limit	7.038/7.058 mm (0.2771/0.2779 in.) 7.159 mm (0.2819 in.)
Valve Guide Reamer Size Standard 0.25 mm O.S.	7.048 mm (0.2775 in.) 7.298 mm (0.2873 in.)
Nominal Valve Face Angle	45°

<sup>4</sup> Values are in Metric units. Values in parentheses are English equivalents.

## GENERAL TORQUE VALUES

English Fastener Torque Recommendations for Standard Applications				
Bolts, Screws, Nuts and Fasteners Assembled Into Cast Iron or Steel				Grade 2 or 5 Fasteners Into Aluminum
Size	 Grade 2	 Grade 5	 Grade 8	
<b>Tightening Torque: N·m (in. lb.) ± 20%</b>				
8-32	2.3 (20)	2.8 (25)	—	2.3 (20)
10-24	3.6 (32)	4.5 (40)	—	3.6 (32)
10-32	3.6 (32)	4.5 (40)	—	—
1/4-20	7.9 (70)	13.0 (115)	18.7 (165)	7.9 (70)
1/4-28	9.6 (85)	15.8 (140)	22.6 (200)	—
5/16-18	17.0 (150)	28.3 (250)	39.6 (350)	17.0 (150)
5/16-24	18.7 (165)	30.5 (270)	—	—
3/8-16	29.4 (260)	—	—	—
3/8-24	33.9 (300)	—	—	—

Tightening Torque: N·m (ft. lb.) ± 20%				
5/16-24	—	—	40.7 (30)	—
3/8-16	—	47.5 (35)	67.8 (50)	—
3/8-24	—	54.2 (40)	81.4 (60)	—
7/16-14	47.5 (35)	74.6 (55)	108.5 (80)	—
7/16-20	61.0 (45)	101.7 (75)	142.5 (105)	—
1/2-13	67.8 (50)	108.5 (80)	155.9 (115)	—
1/2-20	94.9 (70)	142.4 (105)	223.7 (165)	—
9/16-12	101.7 (75)	169.5 (125)	237.3 (175)	—
9/16-18	135.6 (100)	223.7 (165)	311.9 (230)	—
5/8-11	149.5 (110)	244.1 (180)	352.6 (260)	—
5/8-18	189.8 (140)	311.9 (230)	447.5 (330)	—
3/4-10	199.3 (147)	332.2 (245)	474.6 (350)	—
3/4-16	271.2 (200)	440.7 (325)	637.3 (470)	—

Metric Fastener Torque Recommendations for Standard Applications						
Size	Property Class					Noncritical Fasteners Into Aluminum
	 4.8	 5.8	 8.8	 10.9	 12.9	
<b>Tightening Torque: N·m (in. lb.) ± 10%</b>						
M4	1.2 (11)	1.7 (15)	2.9 (26)	4.1 (36)	5.0 (44)	2.0 (18)
M5	2.5 (22)	3.2 (28)	5.8 (51)	8.1 (72)	9.7 (86)	4.0 (35)
M6	4.3 (38)	5.7 (50)	9.9 (88)	14.0 (124)	16.5 (146)	6.8 (60)
M8	10.5 (93)	13.6 (120)	24.4 (216)	33.9 (300)	40.7 (360)	17.0 (150)
<b>Tightening Torque: N·m (ft. lb.) ± 10%</b>						
M10	21.7 (16)	27.1 (20)	47.5 (35)	66.4 (49)	81.4 (60)	33.9 (25)
M12	36.6 (27)	47.5 (35)	82.7 (61)	116.6 (86)	139.7 (103)	61.0 (45)
M14	58.3 (43)	76.4 (56)	131.5 (97)	184.4 (136)	219.7 (162)	94.9 (70)

Torque Conversions	
N·m = in. lb. x 0.113	in. lb. = N·m x 8.85
N·m = ft. lb. x 1.356	ft. lb. = N·m x 0.737

## Tools and Aids

Certain quality tools are designed to help you perform specific disassembly, repair, and reassembly procedures. By using these tools, you can properly service engines easier, faster, and safer! In addition, you'll increase your service capabilities and customer satisfaction by decreasing engine downtime.

Here is a list of tools and their source.

NOTE: Not all tools listed are required to service this engine.

### SEPARATE TOOL SUPPLIERS

Rehiko Tools  
Contact your local Rehiko source  
of supply.

SE Tools  
415 Howard St.  
Lapeer, MI 48446  
Phone 810-664-2981  
Toll Free 800-664-2981  
Fax 810-664-8181

Design Technology Inc.  
768 Burr Oak Drive  
Westmont, IL 60559  
Phone 630-920-1300  
Fax 630-920-0011

### TOOLS

Description	Source/Part No.
<b>Alcohol Content Tester</b> For testing alcohol content (%) in reformulated/oxygenated fuels.	Rehiko 25 455 11-S
<b>Camshaft Endplay Plate</b> For checking camshaft endplay.	SE Tools KLR-82405
<b>Camshaft Seal Protector (Aegis)</b> For protecting seal during camshaft installation.	SE Tools KLR-82417
<b>Dual Gauge Cylinder Leakdown Tester</b> For checking combustion retention and if cylinder, piston, rings, or valves are worn. Individual component available: Adapter 12 mm x 14 mm (Required for leakdown test on XT-6 engines)	Rehiko 25 761 46-S Design Technology Inc. DTI-731-03
<b>Dealer Tool Kit</b> Complete kit of Rehiko required tools. Components of 25 761 39-S Ignition System Tester Dual Gauge Cylinder Leakdown Test Tool Oil Pressure Test Kit Digital Vacuum/Pressure Tester	Rehiko 25 761 39-S  Rehiko 25 455 01-S Rehiko 25 761 46-S Rehiko 25 761 06-S Rehiko 25 455 22-S
<b>Digital Vacuum/Pressure Tester</b> For checking crankcase vacuum. Individual component available: Rubber Adapter Plug	Rehiko 25 455 22-S Design Technology Inc. DTI-721-10
<b>EFI Service Kit</b> For troubleshooting and setting up an EFI engine. Components of 24 761 01-S Fuel Pressure Tester Noid Light 90° Adapter Code Plug, Red Wire Code Plug, Blue Wire Code Plug, Yellow Wire Can Bus Reset Tool, Green Wire Shrader Valve Adapter Hose Wire Probe Set (2 pieces regular wire with clip; 1 piece fused wire) Hose Removal Tool, Dual Size/End (also sold as individual Rehiko tool) K-Line Adapter Jumper Lead Wiring Harness	Rehiko 24 761 01-S Design Technology Inc. DTI-019 DTI-021 DTI-023 DTI-027 DTI-029 DTI-028 DTI-030 DTI-037 DTI-031 DTI-033 Rehiko 25 176 23-S
<b>Rehiko Diagnostic System (KDS) Gen 2</b> For Laptop or Desktop PC. Components of 25 761 50-S Engine Communication Module 7 Pin to DB9 Cable USB Module to PC Cable 7 Pin to 4 Pin Adapter	Rehiko 25 761 50-S  Rehiko 25 761 47-S Rehiko 25 761 48-S Rehiko 25 761 49-S Rehiko 25 761 53-S
<b>Mobile KDS (Wireless) Module</b> For mobile Android or iOS EFI diagnostics. Individual component available: Wireless Diagnostic System Interface Cable	Rehiko 25 761 45-S  Rehiko 25 761 44-S

**TOOLS**

Description	Source/Part No.
<b>Flywheel Puller</b> For properly removing flywheel from engine.	SE Tools KLR-82408
<b>Flywheel Anchor Bolts, Washers, Nuts Tool</b> Used with Flywheel Puller for properly removing flywheel from 5400 Series engine.	Rehiko 25 086 753-S
<b>Hose Removal Tool, Dual Size/End (also available in EFI Service Kit)</b> Used to properly remove fuel hose from engine components.	Rehiko 25 455 20-S
<b>Ignition System Tester</b> For testing output on all systems, including CD.	Rehiko 25 455 01-S
<b>Inductive Tachometer (Digital)</b> For checking operating speed (RPM) of an engine.	Design Technology Inc. DTI-110
<b>Oil Pressure Test Kit</b> For testing/verifying oil pressure on pressure lubricated engines.	Rehiko 25 761 06-S
<b>Rectifier-Regulator Tester (120 volt current)</b> <b>Rectifier-Regulator Tester (240 volt current)</b> For testing rectifier-regulators. Components of 25 761 20-S and 25 761 41-S CS-PRO Regulator Test Harness Special Regulator Test Harness with Diode	Rehiko 25 761 20-S Rehiko 25 761 41-S  Design Technology Inc. DTI-031R DTI-033R
<b>Spark Advance Module (SAM) Tester</b> For testing SAM (ASAM and DSAM) on engines with SMART-SPARK™.	Rehiko 25 761 40-S
<b>Starter Servicing Kit (All Starters)</b> For removing and reinstalling drive retaining rings and brushes. Individual component available: Starter Brush Holding Tool (Solenoid Shift)	SE Tools KLR-82411  SE Tools KLR-82416
<b>Stepper Motor Controller Tool</b> For testing operation of stepper motor/Digital Linear Actuator (DLA).	Rehiko 25 455 21-S
<b>Jumper Lead Tool</b> For use with Stepper Motor Controller Tool to test rotary stepper motor.	Rehiko 25 518 43-S
<b>Triad/OHC Timing Tool Set</b> For holding cam gears and crankshaft in timed position while installing timing belt.	Rehiko 28 761 01-S
<b>Valve Guide Reamer (K and M Series)</b> For properly sizing valve guides after installation.	Design Technology Inc. DTI-K828
<b>Valve Guide Reamer O.S. (Command Series)</b> For reaming worn valve guides to accept replacement oversize valves. Can be used in low-speed drill press or with handle below for hand reaming.	Rehiko 25 455 12-S
<b>Reamer Handle</b> For hand reaming using Rehiko 25 455 12-S reamer.	Design Technology Inc. DTI-K830

**AIDS**

Description	Source/Part No.
<b>Camshaft Lubricant (Valspar ZZ613)</b>	Rehiko 25 357 14-S
<b>Dielectric Grease</b>	Loctite® 51360
<b>Rehiko Electric Starter Drive Lubricant (Inertia Drive)</b>	Rehiko 52 357 01-S
<b>P80 Emulsion Lubricant</b>	Rehiko 25 357 80-S
<b>RTV Silicone Sealant</b> Loctite® 5900® Heavy Body in 4 oz. aerosol dispenser. Only oxime-based, oil resistant RTV sealants, such as those listed, are approved for use. Permatex® the Right Stuff® 1 Minute Gasket™ or Loctite® Nos. 5900® or 5910® are recommended for best sealing characteristics.	Rehiko 25 597 07-S Loctite® 5910® Loctite® Ultra Black 598™ Loctite® Ultra Blue 587™ Loctite® Ultra Copper 5920™ Permatex® the Right Stuff® 1 Minute Gasket™
<b>Spline Drive Lubricant</b>	Rehiko 25 357 12-S

## Tools and Aids

### FLYWHEEL HOLDING TOOL

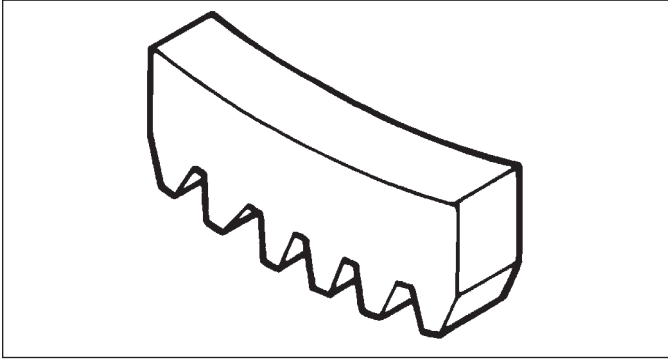

A flywheel holding tool can be made out of an old junk flywheel ring gear and used in place of a strap wrench.

1. Using an abrasive cut-off wheel, cut out a six tooth segment of ring gear as shown.
2. Grind off any burrs or sharp edges.
3. Invert segment and place it between ignition bosses on crankcase so tool teeth engage flywheel ring gear teeth. Bosses will lock tool and flywheel in position for loosening, tightening, or removing with a puller.

### ROCKER ARM/CRANKSHAFT TOOL

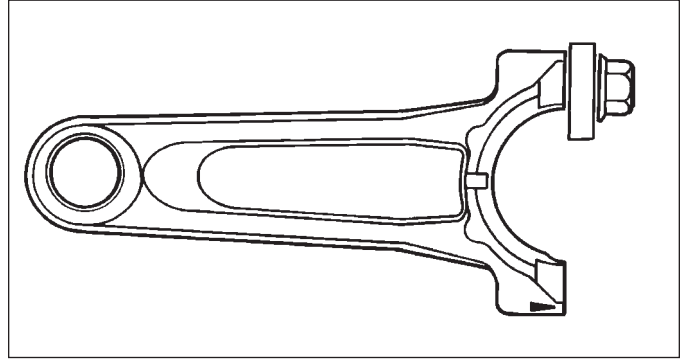

A spanner wrench to lift rocker arms or turn crankshaft may be made out of an old junk connecting rod.

1. Find a used connecting rod from a 10 HP or larger engine. Remove and discard rod cap.
2. Remove studs of a Posi-Lock rod or grind off aligning steps of a Command rod, so joint surface is flat.
3. Find a 1 in. long capscrew with correct thread size to match threads in connecting rod.
4. Use a flat washer with correct I.D. to slip on capscrew and approximately 1 in. O.D. Assemble capscrew and washer to joint surface of rod.

## TROUBLESHOOTING GUIDE

When troubles occur, be sure to check simple causes which, at first, may seem too obvious to be considered. For example, a starting problem could be caused by an empty fuel tank.

Some general common causes of engine troubles are listed below and vary by engine specification. Use these to locate causing factors.

### Engine Cranks But Will Not Start

---

- Battery connected backwards.
- Blown fuse.
- Carburetor solenoid malfunction.
- Choke not closing.
- Clogged fuel line or fuel filter.
- Diode in wiring harness failed in open circuit mode.
- DSAI or DSAM malfunction.
- Empty fuel tank.
- Faulty electronic control unit.
- Faulty ignition coil(s).
- Faulty spark plug(s).
- Fuel pump malfunction-vacuum hose clogged or leaking.
- Fuel shut-off valve closed.
- Ignition module(s) faulty or improperly gapped.
- Insufficient voltage to electronic control unit.
- Interlock switch is engaged or faulty.
- Key switch or kill switch in OFF position.
- Low oil level.
- Quality of fuel (dirt, water, stale, mixture).
- SMART-SPARK™ malfunction.
- Spark plug lead(s) disconnected.

### Engine Starts But Does Not Keep Running

---

- Faulty carburetor.
- Faulty cylinder head gasket.
- Faulty or misadjusted choke or throttle controls.
- Fuel pump malfunction-vacuum hose clogged or leaking.
- Intake system leak.
- Loose wires or connections that intermittently ground ignition kill circuit.
- Quality of fuel (dirt, water, stale, mixture).
- Restricted fuel tank cap vent.

### Engine Starts Hard

---

- Clogged fuel line or fuel filter.
- Engine overheated.
- Faulty ACR mechanism.
- Faulty or misadjusted choke or throttle controls.
- Faulty spark plug(s).
- Flywheel key sheared.
- Fuel pump malfunction-vacuum hose clogged or leaking.
- Interlock switch is engaged or faulty.
- Loose wires or connections that intermittently ground ignition kill circuit.
- Low compression.
- Quality of fuel (dirt, water, stale, mixture).
- Weak spark.

### Engine Will Not Crank

---

- Battery is discharged.
- Faulty electric starter or solenoid.
- Faulty key switch or ignition switch.
- Interlock switch is engaged or faulty.
- Loose wires or connections that intermittently ground ignition kill circuit.
- Pawls not engaging in drive cup.
- Seized internal engine components.

### Engine Runs But Misses

---

- Carburetor adjusted incorrectly.
- Engine overheated.
- Faulty spark plug(s).
- Ignition module(s) faulty or improperly gapped.
- Incorrect crankshaft position sensor air gap.
- Interlock switch is engaged or faulty.
- Loose wires or connections that intermittently ground ignition kill circuit.
- Quality of fuel (dirt, water, stale, mixture).
- Spark plug lead(s) disconnected.
- Spark plug lead boot loose on plug.
- Spark plug lead loose.

### Engine Will Not Idle

---

- Engine overheated.
- Faulty spark plug(s).
- Idle fuel adjusting needle(s) improperly set.
- Idle speed adjusting screw improperly set.
- Inadequate fuel supply.
- Low compression.
- Quality of fuel (dirt, water, stale, mixture).
- Restricted fuel tank cap vent.

### Engine Overheats

---

- Cooling fan broken.
- Excessive engine load.
- Fan belt failed/off.
- Faulty carburetor.
- High crankcase oil level.
- Lean fuel mixture.
- Low cooling system fluid level.
- Low crankcase oil level.
- Radiator, and/or cooling system components clogged, restricted, or leaking.
- Water pump belt failed/broken.
- Water pump malfunction.

### Engine Knocks

---

- Excessive engine load.
- Hydraulic lifter malfunction.
- Incorrect oil viscosity/type.
- Internal wear or damage.
- Low crankcase oil level.
- Quality of fuel (dirt, water, stale, mixture).

# Troubleshooting

## Engine Loses Power

---

- Dirty air cleaner element.
- Engine overheated.
- Excessive engine load.
- Restricted exhaust.
- Faulty spark plug(s).
- High crankcase oil level.
- Incorrect governor setting.
- Low battery.
- Low compression.
- Low crankcase oil level.
- Quality of fuel (dirt, water, stale, mixture).

## Engine Uses Excessive Amount of Oil

---

- Loose or improperly torqued fasteners.
- Blown head gasket/overheated.
- Breather reed broken.
- Clogged, broken, or inoperative crankcase breather.
- Crankcase overfilled.
- Incorrect oil viscosity/type.
- Worn cylinder bore.
- Worn or broken piston rings.
- Worn valve stems/valve guides.

## Oil Leaks from Oil Seals, Gaskets

---

- Breather reed broken.
- Clogged, broken, or inoperative crankcase breather.
- Loose or improperly torqued fasteners.
- Piston blow by, or leaky valves.
- Restricted exhaust.

## EXTERNAL ENGINE INSPECTION



NOTE: It is good practice to drain oil at a location away from workbench. Be sure to allow ample time for complete drainage.

Before cleaning or disassembling engine, make a thorough inspection of its external appearance and condition. This inspection can give clues to what might be found inside engines (and cause) when it is disassembled.

- Check for buildup of dirt and debris on crankcase, cooling fins, grass screen, and other external surfaces. Dirt or debris on these areas can cause overheating.
- Check for obvious fuel and oil leaks, and damaged components. Excessive oil leakage can indicate a clogged or inoperative breather, worn or damaged seals or gaskets, or loose fasteners.
- Check air cleaner cover and base for damage or indications of improper fit and seal.
- Check air cleaner element. Look for holes, tears, cracked or damaged sealing surfaces, or other damage that could allow unfiltered air into engine. A dirty or clogged element could indicate insufficient or improper maintenance.
- Check carburetor throat for dirt. Dirt in throat is further indication that air cleaner was not functioning properly.
- Check if oil level is within operating range on dipstick. If it is above, sniff for gasoline odor.
- Check condition of oil. Drain oil into a container; it should flow freely. Check for metal chips and other foreign particles.

Sludge is a natural by-product of combustion; a small accumulation is normal. Excessive sludge formation could indicate over rich fuel settings, weak ignition, overextended oil change interval or wrong weight or type of oil was used.

## CLEANING ENGINE

	 <b>WARNING</b>
	Cleaning Solvents can cause severe injury or death. Use only in well ventilated areas away from ignition sources.
Carburetor cleaners and solvents are extremely flammable. Follow cleaner manufacturer's warnings and instructions on its proper and safe use. Never use gasoline as a cleaning agent.	

After inspecting external condition of engine, clean engine thoroughly before disassembly. Clean individual components as engine is disassembled. Only clean parts can be accurately inspected and gauged for wear or damage. There are many commercially available cleaners that will quickly remove grease, oil, and grime from engine parts. When such a cleaner is used, follow manufacturer's instructions and safety precautions carefully.

Make sure all traces of cleaner are removed before engine is reassembled and placed into operation. Even small amounts of these cleaners can quickly break down lubricating properties of engine oil.

## CRANKCASE VACUUM TEST

	<b>⚠ WARNING</b>
	Carbon Monoxide can cause severe nausea, fainting or death. Avoid inhaling exhaust fumes. Never run engine indoors or in enclosed spaces.
Engine exhaust gases contain poisonous carbon monoxide. Carbon monoxide is odorless, colorless, and can cause death if inhaled.	

	<b>⚠ WARNING</b>
	Rotating Parts can cause severe injury. Stay away while engine is in operation.
Keep hands, feet, hair, and clothing away from all moving parts to prevent injury. Never operate engine with covers, shrouds, or guards removed.	

A partial vacuum should be present in crankcase when engine is operating. Pressure in crankcase (normally caused by a clogged or improperly assembled breather) can cause oil to be forced out at oil seals, gaskets, or other available spots.

Crankcase vacuum is best measured with either a water manometer or a vacuum gauge. Complete instructions are provided in kits.

To test crankcase vacuum with manometer:

1. Insert rubber stopper into oil fill hole. Be sure pinch clamp is installed on hose and use tapered adapters to connect hose between stopper and one manometer tube. Leave other tube open to atmosphere. Check that water level in manometer is at 0 line. Make sure pinch clamp is closed.
2. Start engine and run no-load high speed.
3. Open clamp and note water level in tube.  
Level in engine side should be a minimum of 10.2 cm (4 in.) above level in open side.  
If level in engine side is less than specified (low/no vacuum), or level in engine side is lower than level in open side (pressure), check for conditions in table below.
4. Close pinch clamp before stopping engine.

To test crankcase vacuum with vacuum/pressure gauge:

1. Remove dipstick or oil fill plug/cap.
2. Install adapter into oil fill/dipstick tube opening, upside down over end of a small diameter dipstick tube, or directly into engine if a tube is not used. Insert barbed gauge fitting into hole in stopper.
3. Run engine and observe gauge reading.  
Analog tester—needle movement to left of 0 is a vacuum, and movement to right indicates a pressure.  
Digital tester—depress test button on top of tester.  
Crankcase vacuum should be a minimum of 10.2 cm (4 in.) of water. If reading is below specification, or if pressure is present, check table below for possible causes and conclusions.

Condition	Conclusion
Crankcase breather clogged or inoperative.	NOTE: If breather is integral part of valve cover and cannot be serviced separately, replace valve cover and recheck pressure. Disassemble breather, clean parts thoroughly, check sealing surfaces for flatness, reassemble, and recheck pressure.
Seals and/or gaskets leaking. Loose or improperly torque fasteners.	Replace all worn or damaged seals and gaskets. Make sure all fasteners are tightened securely. Use appropriate torque values and sequences when necessary.
Piston blow by or leaky valves (confirm by inspecting components).	Recondition piston, rings, cylinder bore, valves and valves guides.
Restricted exhaust.	Check exhaust screen/spark arrestor (if equipped). Clean or replace as needed. Repair or replace any other damaged/restricted muffler or exhaust system parts.

# Troubleshooting

## COMPRESSION TEST

For Command Twins:

A compression test is best performed on a warm engine. Clean any dirt or debris away from base of spark plug(s) before removing them. Be sure choke is off, and throttle is wide open during test. Compression should be at least 160 psi and should not vary more than 15% between cylinders.

All other models:

These engines are equipped with an automatic compression release (ACR) mechanism. It is difficult to obtain an accurate compression reading because of ACR mechanism. As an alternative, use cylinder leakdown test described below.

## CYLINDER LEAKDOWN TEST

A cylinder leakdown test can be a valuable alternative to a compression test. By pressurizing combustion chamber from an external air source you can determine if valves or rings are leaking, and how badly.

Cylinder leakdown tester is a relatively simple, inexpensive leakdown tester for small engines. This tester includes a quick-connect for attaching adapter hose and a holding tool.

1. Run engine for 3-5 minutes to warm it up.
2. Remove spark plug(s) and air filter from engine.
3. Rotate crankshaft until piston (of cylinder being tested) is at top dead center (TDC) of compression stroke. Hold engine in this position while testing. Holding tool supplied with tester can be used if PTO end of crankshaft is accessible. Lock holding tool onto crankshaft. Install a 3/8 in. breaker bar into hole/slot of holding tool, so it is perpendicular to both holding tool and crankshaft PTO.  
If flywheel end is more accessible, use a breaker bar and socket on flywheel nut/screw to hold it in position. An assistant may be needed to hold breaker bar during testing. If engine is mounted in a piece of equipment, it may be possible to hold it by clamping or wedging a driven component. Just be certain that engine cannot rotate off of TDC in either direction.
4. Install adapter into spark plug hole, but do not attach it to tester at this time.
5. Turn regulator knob completely counterclockwise.
6. Connect an air source of at least 50 psi to tester.
7. Turn regulator knob clockwise (increase direction) until gauge needle is in yellow set area at low end of scale.
8. Connect tester quick-connect to adapter hose. While firmly holding engine at TDC, gradually open tester valve. Note gauge reading and listen for escaping air at combustion air intake, exhaust outlet, and crankcase breather.

Condition	Conclusion
Air escaping from crankcase breather.	Ring or cylinder worn.
Air escaping from exhaust system.	Defective exhaust valve/improper seating.
Air escaping from intake.	Defective intake valve/improper seating.
Gauge reading in low (green) zone.	Piston rings and cylinder in good condition.
Gauge reading in moderate (yellow) zone.	Engine is still usable, but there is some wear present. Customer should start planning for overhaul or replacement.
Gauge reading in high (red) zone.	Rings and/or cylinder have considerable wear. Engine should be reconditioned or replaced.

## AIR CLEANER

These systems are CARB/EPA certified and components should not be altered or modified in any way.

### Low-Profile Air Cleaner Components

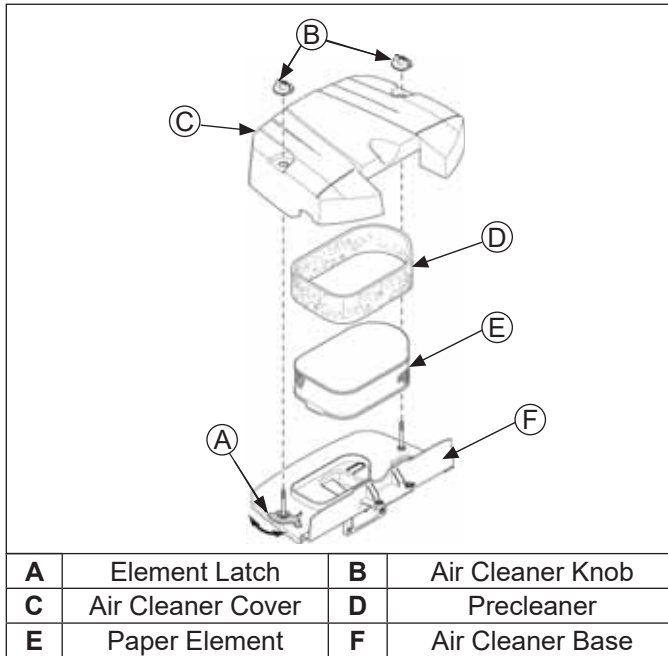

### Heavy-Duty Air Cleaner Components

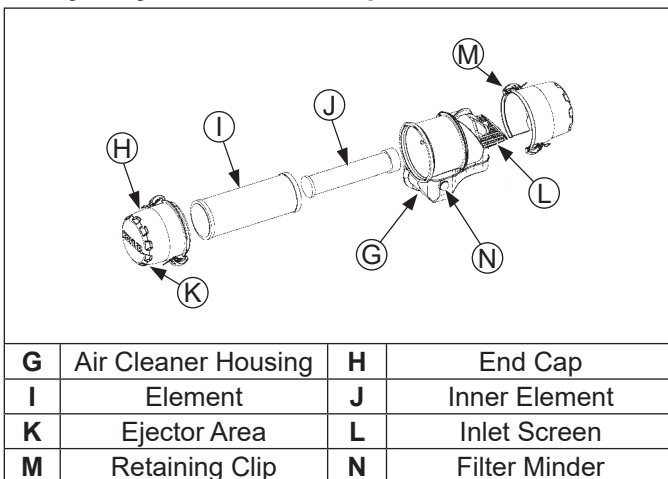

NOTE: Operating engine with loose or damaged air cleaner components could cause premature wear and failure. Replace all bent or damaged components.

NOTE: Paper element cannot be blown out with compressed air.

### Low-Profile

Loosen knobs and remove air cleaner cover.

#### Precleaner

1. Remove precleaner from paper element.
2. Replace or wash precleaner in warm water with detergent. Rinse and allow to air dry.
3. Saturate precleaner with new engine oil; squeeze out excess oil.
4. Reinstall precleaner over paper element.

#### Paper Element

1. Rotate element latch (if equipped); remove paper element with precleaner.
2. Separate precleaner from element; service precleaner and replace paper element.
3. Install new paper element on base; install precleaner over paper element; rotate element latch (if equipped).

Reinstall air cleaner cover and secure with knobs.

### Heavy-Duty

1. Unhook retaining clips and remove end cap(s).
2. Check and clean inlet screen (if equipped).
3. Pull air cleaner element out of housing and replace. Check condition of inner element; replace when dirty.
4. Check all parts for wear, cracks, or damage, and that ejector area is clean.
5. Install new element(s).
6. Reinstall end cap(s) with dust ejector valve/screen down; secure with retaining clips.

### BREATHER TUBE

Ensure both ends of breather tube are properly connected.

### AIR COOLING

	<b>WARNING</b>
	<p>Hot Parts can cause severe burns. Do not touch engine while operating or just after stopping.</p>
<p>Never operate engine with heat shields or guards removed.</p>	

Proper cooling is essential. To prevent over heating, clean screens, cooling fins, and other external surfaces of engine. Avoid spraying water at wiring harness or any electrical components. Refer to Maintenance Schedule.

# Fuel System

Typical carbureted fuel system and related components include:

- Fuel tank and valve.
- Fuel lines.
- In-line fuel filter.
- Fuel pump.
- Carburetor.

Fuel from tank is moved through in-line filter and fuel lines by fuel pump. Fuel then enters carburetor float bowl and is drawn into carburetor body and mixed with air. This fuel-air mixture is then burned in engine combustion chamber.

## FUEL RECOMMENDATIONS

Refer to Maintenance.

## FUEL LINE

Low permeation fuel line must be installed on carbureted Rehlko engines to maintain EPA and CARB regulatory compliance.

## FUEL SYSTEM TESTS

When engine starts hard or turns over but will not start, fuel system might be causing problems. Test fuel system by performing following test.

1. Check for fuel in combustion chamber.
  - a. Disconnect and ground spark plug leads.
  - b. Close choke on carburetor.
  - c. Crank engine several times.
  - d. Remove spark plug and check for fuel at tip.
2. Check for fuel flow from tank to fuel pump.
  - a. Remove fuel line from inlet fitting of fuel pump.
  - b. Hold line below bottom of tank. Open shut-off valve (if equipped) and observe flow.
3. Check operation of fuel pump.
  - a. Remove fuel line from inlet fitting of carburetor.
  - b. Crank engine several times and observe flow.

## FUEL PUMP

These engines use either a mechanical fuel pump, or optional remote-mounted electric fuel pump assembly. Operation of mechanical fuel pump occurs by direct lever/pump actuation off rocker arm movement. Pumping action causes diaphragm on inside of pump to pull fuel in on its downward stroke and to push it into carburetor on its upward stroke, internal check valves prevent fuel from going backward through pump.



## Fuel Pump Replacement

Mechanical fuel pump is an integral part of valve cover assembly and not serviced separately.

1. Disconnect fuel lines from inlet and outlet fittings. Note orientation.
2. Follow procedure for replacing valve cover. Refer to Disassembly and Reassembly.
3. Reconnect fuel lines to inlet and outlet fittings and secure with clamps.

Condition	Conclusion
Fuel at tip of spark plug.	Fuel is reaching combustion chamber.
No fuel at tip of spark plug.	Check fuel flow from fuel tank (step 2).
Fuel flows from fuel line.	Check for faulty fuel pump (step 3). If fuel pump is working, check for faulty carburetor. Refer to Carburetor.
No fuel flow from fuel line.	Check fuel tank cap vent, fuel pickup screen, in-line filter, shut-off valve, and fuel line. Correct any observed problem and reconnect line.
Fuel line condition.	Check for a clogged fuel line. If fuel line is unobstructed, check for overfilled crankcase and/or oil in pulse line. If checks don't reveal cause of problem, replace pump.

**CARBURETOR**

	 <b>WARNING</b>	Gasoline is extremely flammable and its vapors can explode if ignited. Store gasoline only in approved containers, in well ventilated, unoccupied buildings, away from sparks or flames. Spilled fuel could ignite if it comes in contact with hot parts or sparks from ignition. Never use gasoline as a cleaning agent.
	Explosive Fuel can cause fires and severe burns. Do not fill fuel tank while engine is hot or running.	

**Two-Barrel Carburetor Components**

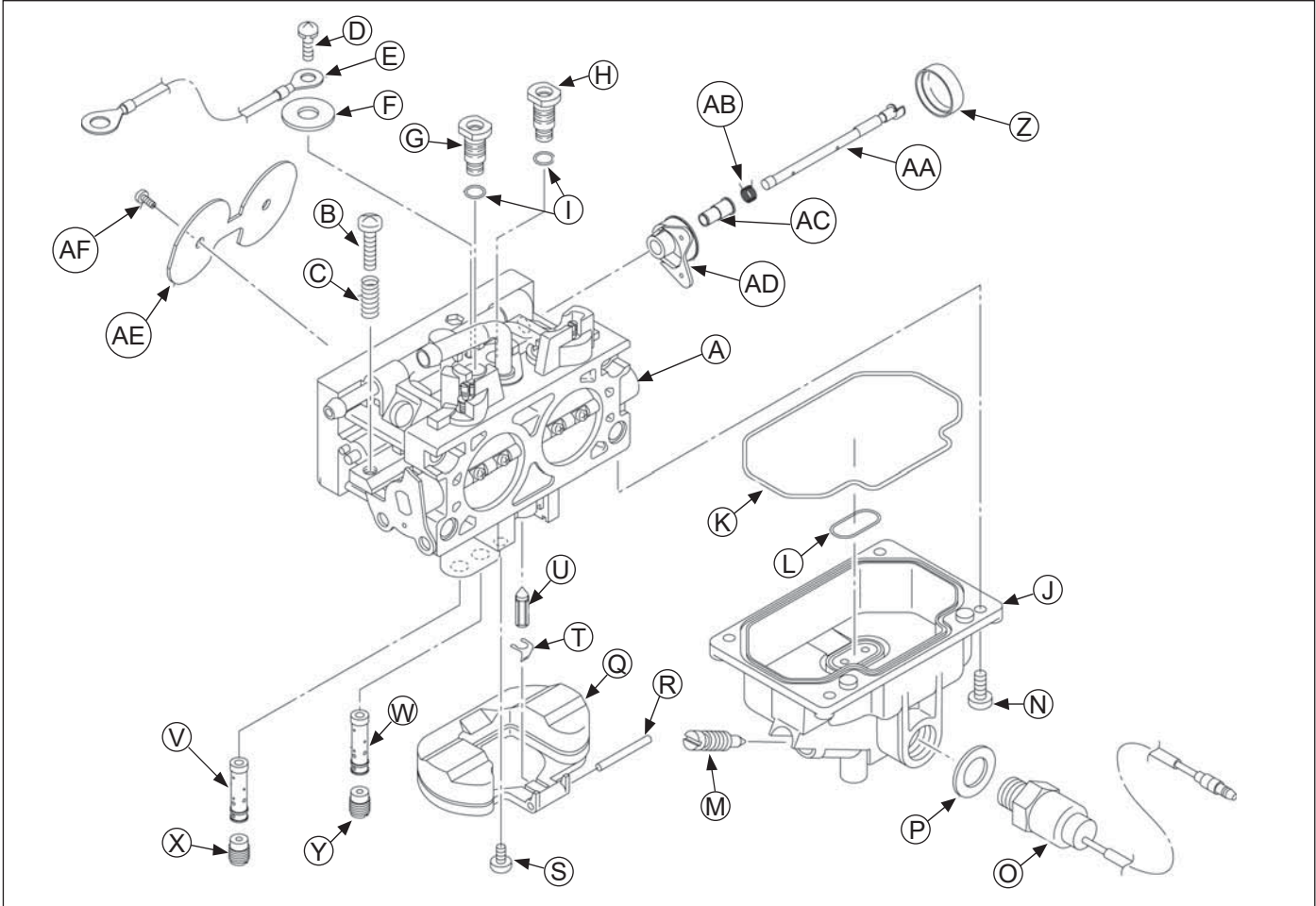

<b>A</b>	Carburetor Body Subassembly	<b>B</b>	Idle Speed Screw	<b>C</b>	Idle Speed Spring	<b>D</b>	Screw	<b>E</b>	Ground Lead
<b>F</b>	Retaining Washer	<b>G</b>	Slow Jet-Right Side	<b>H</b>	Slow Jet-Left Side	<b>I</b>	O-ring (Slow Jet)	<b>J</b>	Fuel Bowl
<b>K</b>	O-ring (Fuel Bowl-Upper)	<b>L</b>	O-ring (Fuel Bowl-Lower)	<b>M</b>	Drain Screw	<b>N</b>	Bowl Screw	<b>O</b>	Fuel Solenoid
<b>P</b>	Sealing Washer	<b>Q</b>	Float	<b>R</b>	Pin	<b>S</b>	Screw	<b>T</b>	Float Clip
<b>U</b>	Float Valve/Inlet Needle	<b>V</b>	Main Nozzle-Right Side	<b>W</b>	Main Nozzle-Left Side	<b>X</b>	Main Jet-Right Side	<b>Y</b>	Main Jet-Left Side
<b>Z</b>	Choke Dust Cap	<b>AA</b>	Choke Shaft	<b>AB</b>	Spring	<b>AC</b>	Bushing	<b>AD</b>	Choke Lever
<b>AE</b>	Choke Plate	<b>AF</b>	Choke Plate Screw						

# Fuel System

Engines in this series are equipped with a two-barrel, side-draft carburetor with fixed main jets on a matching intake manifold. Carburetor features a self-relieving choke, serviceable slow jets, main jets, bowl drain and a fuel shutdown solenoid.

## Troubleshooting Checklist

When engine starts hard, runs rough, or stalls at low idle speed, check these areas before adjusting or disassembling carburetor.

1. Make sure fuel tank is filled with clean, fresh gasoline.
2. Make sure fuel tank cap vent is not blocked and is operating properly.
3. Make sure fuel is reaching carburetor. This includes checking fuel shut-off valve, fuel tank filter screen, in-line fuel filter, fuel lines and fuel pump for restrictions or faulty components as necessary.

4. Make sure air cleaner base and carburetor are securely fastened to engine using gaskets in good condition.
5. Make sure air cleaner element (including precleaner if equipped) is clean and all air cleaner components are fastened securely.
6. Make sure ignition system, governor system, exhaust system, and throttle and choke controls are operating properly.

## Troubleshooting-Carburetor Related Causes

Condition	Possible Cause	Conclusion
Engine starts hard, runs rough, or stalls at idle speed.	Low idle fuel mixture (some models)/ speed improperly adjusted.	Adjust low idle speed tab, then adjust low idle fuel needle.
Engine runs rich (indicated by black, sooty exhaust smoke, misfiring, loss of speed and power, governor hunting, or excessive throttle opening).	Clogged air cleaner.	Clean or replace air cleaner.
	Choke partially closed during operation.	Check choke lever/linkage to ensure choke is operating properly.
	Low idle fuel mixture is improperly adjusted.	Adjust low idle fuel needle (some models).
	Float level is set too high.	Adjust float according to Float Replacement Procedure.
	Dirt under fuel inlet needle.	Remove needle; clean needle and seat and blow with compressed air.
	Bowl vent or air bleeds plugged.	Remove low idle fuel adjusting needle. Clean vent, ports, and air bleeds. Blow out all passages with compressed air.
Engine runs lean (indicated by misfiring, loss of speed and power, governor hunting, or excessive throttle opening).	Leaky, cracked, or damaged float.	Submerge float to check for leaks.
	Low idle fuel mixture is improperly adjusted.	Adjust low idle fuel needle (some models).
	Float level is set too low.	Adjust float according to Float Replacement Procedure.
Fuel leaks from carburetor.	Idle holes plugged; dirt in fuel delivery channels.	Remove low idle fuel adjusting needle. Clean main fuel jet and all passages; blow out with compressed air.
	Float level set too high.	Adjust float according to Float Replacement Procedure.
	Dirt under fuel inlet needle.	Remove needle; clean needle and seat and blow with compressed air.
	Bowl vents plugged.	Blow out with compressed air.
	Carburetor bowl gasket leaks.	Replace gasket.

## Fuel Shut-off Solenoid

Most carburetors are equipped with a fuel shut-off solenoid. Solenoid is attached to fuel bowl. Solenoid has a spring-loaded pin that retracts when 12 volts is applied to lead, allowing fuel flow to main jets. When current is removed pin extends blocking fuel flow.

Below is a simple test, performed with engine off, that can determine if solenoid is functioning properly:

1. Shut off fuel and remove solenoid from carburetor. When solenoid is loosened and removed, gas will leak out of carburetor. Have a container ready to catch fuel.
2. Wipe tip of solenoid with a shop towel or blow with compressed air to remove any remaining fuel. Take solenoid to a location with good ventilation and no fuel vapors present. You will also need a 12 volt power source that can be switched on and off.
3. Be sure power source is switched OFF. Connect positive power source lead to red lead of solenoid. Connect negative power source lead to solenoid body.
4. Turn power source ON and observe pin in center of solenoid. Pin should retract with power ON and return to its original position with power OFF. Test several times to verify operation.

## Carburetor Circuits

### Float

Fuel level in bowl is maintained by float and fuel inlet needle. Buoyant force of float stops fuel flow when engine is at rest. When fuel is being consumed, float will drop and fuel pressure will push inlet needle away from seat, allowing more fuel to enter bowl. When demand ceases, buoyant force of float will again overcome fuel pressure, rising to predetermined setting and stop flow.

### Slow and Mid-Range

At low speeds engine operates only on slow circuit. As a metered amount of air is drawn through slow air bleed jets, fuel is drawn through 2 main jets and further metered through slow jets. Air and fuel are mixed in body of slow jet and exit to transfer port. From transfer port, air fuel mixture is delivered to idle progression chamber. From idle progression chamber, air fuel mixture is metered through idle port passages. At low idle when vacuum signal is weak, air/fuel mixture is controlled by setting of idle fuel adjusting screws. This mixture is then mixed with main body of air and delivered to engine. As throttle plate opening increases, greater amounts of air/fuel mixture are drawn in through fixed and metered idle progression holes. As throttle plate opens further, vacuum signal becomes great enough so main circuit begins to work.

### Main (high-speed)

At high speeds/loads engine operates on main circuit. As a metered amount of air is drawn through 4 air jets, fuel is drawn through main jets. Air and fuel are mixed in main nozzles then enter main body of airflow where further mixing of fuel and air occurs. This mixture is then delivered to combustion chamber. Carburetor has a fixed main circuit; no adjustment is possible.

## Carburetor Adjustments

NOTE: Carburetor adjustments should be made only after engine has warmed up.

Carburetor is designed to deliver correct fuel-to-air mixture to engine under all operating conditions. Main fuel jet is calibrated at factory and is not adjustable. Idle fuel adjusting needles are also set at factory and normally do not need adjustment.

### Low Idle Speed (RPM) Adjustment

NOTE: Actual low idle speed depends on application. Refer to equipment manufacturer's recommendations. Low idle speed for basic engines is 1200 RPM. To ensure best results when setting low idle fuel needle, low idle speed should be 1200 RPM ( $\pm$  75 RPM).

1. Place throttle control into idle or slow position. Turn low idle speed adjusting screw in or out to obtain a low idle speed of 1200 RPM ( $\pm$  75 RPM).

### Governed Idle Speed Adjustment

1. Make sure governed idle spring is in outer hole in governor lever and hole in governed idle (outer) adjuster.
2. Make sure governor spring is in inner slot of governor lever and hole in high speed (inner) adjuster. Pull governor lever away from carburetor to limit its travel and check that governor spring is loose and not under any tension. Turn high-speed (RPM) adjustment screw counterclockwise (if required) until spring is loose.
3. Hold governor lever away from carburetor so throttle lever is against idle speed (RPM) adjustment screw of carburetor. Start engine and allow to warm up, then adjust screw to set approximately 1200 RPM. Check speed using a tachometer. Turn adjustment screw (inner) clockwise (in) to increase or counterclockwise (out) to decrease speed.
4. Release governor lever and check that throttle lever is in idle (centered) position. Turn governed idle (outer) adjustment screw to obtain equipment manufacturer's recommended idle speed (1500-1800 RPM). Governed idle speed (RPM) is typically 300 RPM (approximate) higher than low idle speed.
5. Move throttle lever to wide-open/full throttle position and hold in this position. Turn high speed screw to obtain intended high speed no-load RPM. Governed idle speed must be set before making this adjustment.

### Low Idle Fuel Adjustment

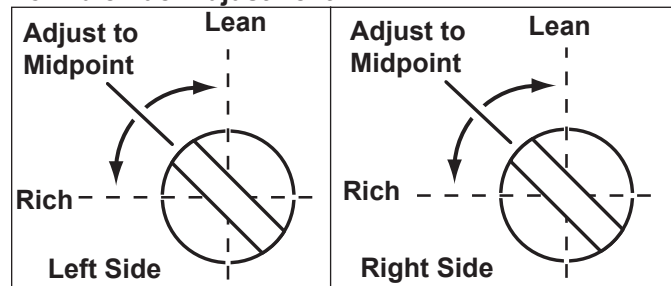

# Fuel System





NOTE: Engines will have fixed low idle or limiter caps on idle fuel adjusting needles. Step 2 can only be performed within limits allowed by cap. Do not attempt to remove limiter caps.

1. Place throttle control into idle or slow position. Adjust low idle speed to 1200 RPM. Follow Low Idle Speed (RPM) Adjustment.
2. Low idle fuel needle(s) setting: place throttle into idle or slow position.
  - a. Turn 1 low idle fuel adjusting needle out (counterclockwise) from preliminary setting until engine speed decreases (rich). Note position of needle. Now turn adjusting needle in (clockwise). Engine speed may increase, then it will decrease as needle is turned in (lean). Note position of needle. Set adjusting needle midway between rich and lean settings.
  - b. Repeat procedure on other low idle adjustment needle.
3. Recheck/adjust Low Idle Speed (RPM) to specified setting.

## High Speed (RPM) Adjustment

1. With engine running, move throttle control to fast.
2. Turn inner adjustment screw outward to decrease, or inward to increase RPM speed.
3. Stop when desired RPM speed is obtained.

## Carburetor Servicing

	 <b>WARNING</b>
	Accidental Starts can cause severe injury or death.
	Disconnect and ground spark plug lead(s) before servicing.
Before working on engine or equipment, disable engine as follows: 1) Disconnect spark plug lead(s). 2) Disconnect negative (-) battery cable from battery.	

NOTE: Main and slow jets are fixed and side specific and can be removed if required. Fixed jets for high altitudes are available.

- Inspect carburetor body for cracks, holes, and other wear or damage.
- Inspect float for cracks, holes, and missing or damaged float tabs. Check float hinge and shaft for wear or damage.
- Inspect fuel inlet needle and seat for wear or damage.
- Inspect spring loaded choke plate to make sure it moves freely on shaft.

## Float Replacement/Overhaul/Choke Repair

NOTE: Inlet needle center pin is spring loaded. Make sure float rests against fuel inlet needle without depressing center pin.

If symptoms described in Troubleshooting-Carburetor Related Causes indicate float level problems, remove carburetor from engine to check and/or replace float. Use a float kit to replace float, pin, float valve, clip, and screw.

1. Perform removal procedures for appropriate air cleaner and carburetor outlined in Disassembly.
2. Clean exterior surfaces of dirt or foreign material before disassembling carburetor. Remove screws and carefully separate fuel bowl from carburetor. Do not damage fuel bowl O-rings. Transfer any remaining fuel into an approved container. Save all parts. Fuel can also be drained prior to bowl removal by loosening/removing bowl drain screw.
3. Remove screw and lift out old float, pin, and inlet needle. Discard all of parts. Seat for inlet needle is not serviceable and should not be removed.
4. Clean carburetor bowl and inlet seat areas as required. To reassemble fuel bowl go to step 23, otherwise go to step 5.
5. Carefully remove main jets from carburetor. Note and mark jets by location for proper reassembly. Main jets may be size/side specific. After main jets are removed, main nozzles can be removed out through bottom of main towers. Note orientation/direction of nozzles. End with 2 raised shoulders should be out/down adjacent to main jets. Save parts for cleaning and reuse.
6. Remove screw securing flat washer and ground lead (if equipped) from top of carburetor, then carefully pull (lift) out slow jets. Slow jets may be sized/side specific. Mark or tag jets for proper reassembly. Note small O-ring on bottom of each jet. Save parts for cleaning and reuse unless a jet kit is also being installed. Clean slow jets using compressed air. Do not use wire or carburetor cleaner.
7. Remove idle speed (RPM) adjustment screw and spring from carburetor. Discard parts.  
Carburetor is now disassembled for appropriate cleaning and installation of parts in overhaul kit. Further disassembly is not necessary. Throttle shaft assembly, fuel inlet seat, idle fuel adjustment screws with limiter, and carburetor body, are non-serviceable items and should not be removed. Choke shaft assembly is serviceable, however it should not be removed unless a choke repair kit will be installed.  
To install choke repair kit go to step 8, otherwise go to step 18.
8. Remove and discard plastic cap from end of choke lever/shaft assembly.
9. Note position of spring legs and choke plate for correct reassembly later. Remove screws attaching choke plate to choke shaft. Pull shaft out of carburetor body, note preload of spring and discard removed parts.
10. Use a screw extractor (easy-out) and remove original choke shaft bushing with old choke lever from carburetor housing. Save bushing to use as a driver for installing new bushing. Discard old lever.
11. Clean I.D. of both choke shaft bores as required.
12. Insert new bushing through new choke lever from outside and start bushing in outer shaft bore. Position choke lever so protruding boss on carburetor housing is between 2 stops formed in choke lever.

13. Turn old bushing upside down and use it as a driver to carefully press or tap new bushing into carburetor body until it bottoms. Check that choke lever pivots freely without restriction or binding.
14. Install new return spring onto new choke shaft, so outboard leg of spring is behind formed stop on end of choke shaft.  
Make sure it stays in this location during following step.
15. Slide choke shaft and spring into carburetor. Pivot (preload) shaft 3/4 turn counterclockwise with inner leg of spring against formed stop within choke lever as originally assembled. Outer leg of spring must still be behind formed stop of choke shaft.
16. Place a drop of Loctite® 222MS™ on threads of each new screw. Position and install new choke plate to flat side of choke shaft. Start screws. Close choke and check plate alignment within carburetor throat, then tighten screws securely. Do not overtighten.
17. Check for proper operation and free movement of parts. Install new cap.
18. Clean carburetor body, main jets, vent ports, seats, etc., using a good commercially available carburetor solvent. Keep away from plastic or rubber parts if non-compatible. Use clean, dry compressed air to blow out internal channels and ports. Do not use metal tools or wire to clean orifices and jets. Inspect and thoroughly check carburetor for cracks, wear, or damage. Inspect fuel inlet seat for wear or damage. Check spring loaded choke plate to make sure it moves freely on shaft.
19. Install main nozzles into towers of carburetor body. End of main nozzles with 2 raised shoulders should be out/down (adjacent to main jets). Make sure nozzles are completely bottomed. Carefully install main jets into towers of carburetor body on appropriate side, as identified when removal was performed.
20. Make sure O-ring near bottom of each slow jet is new, or in good condition. Align and insert slow jets into top of carburetor.
21. Install large flat retaining washer and secure with mounting screw, attaching ground lead if originally secured by screw.
22. Install new idle speed (RPM) adjustment screw and spring onto carburetor. Thread in until 3 or 4 threads are exposed, as an initial adjustment.
23. Attach inlet needle to plastic tang of float with wire clip. Formed 90° lip should point up, with needle valve hanging down.
24. Install float and inlet needle down into seat and carburetor body. Install new pivot pin through float hinge and secure with new retaining screw.
25. Hold carburetor body so float assembly hangs vertically and rests lightly against fuel inlet needle. Inlet needle should be fully seated but center pin of needle (on retainer clip end) should not be depressed. Check float height adjustment.  
Be sure to measure from casting surface, not rubber gasket, if still attached.
26. Correct float height setting is 17 mm (0.669 in.) ± 1.5 mm (0.059 in.), measured from float bottom to body of carburetor. Replace float if height is different than specified. DO NOT attempt to adjust by bending float tab.
27. When proper float height is obtained, carefully reinstall fuel bowl onto carburetor, using new O-rings. Secure with original screws. Torque screws to 2.5 N·m (22 in. lb.) ± 0.3 N·m (3 in. lb.).
28. Set idle mixture screws at midpoint of available adjustment as a preliminary setting.
29. Use new mounting gaskets for air cleaner and carburetor. Reinstall carburetor and disassembled components following Reassembly procedures.
30. Reconnect spark plug leads and negative battery cable. Start engine and perform Low Idle Speed Adjustment and Low Idle Fuel Needle(s) settings.

## HIGH ALTITUDE OPERATION

If this engine is operated at an altitude of 4000 ft. (1219 meters) or above, a high altitude carburetor kit is required. To obtain high altitude carburetor kit information or to find a Rehlko authorized dealer, visit [engines.rehlko.com](http://engines.rehlko.com) or call 1-800-544-2444 (U.S. and Canada).

This engine should be operated in its original configuration below 4000ft. (1219meters).

Operating this engine with the wrong engine configuration at a given altitude may increase its emissions, decrease fuel efficiency and performance, and result in damage to the engine.

# Governor System

## GOVERNOR

Governed speed setting is determined by position of throttle control. It can be variable or constant, depending on engine application.

Governor is designed to hold engine speed constant under changing load conditions. Most engines are equipped with a centrifugal flyweight mechanical governor. Governor gear/flyweight mechanism of mechanical governor is mounted inside crankcase and is driven off gear on camshaft.

### Governor Components

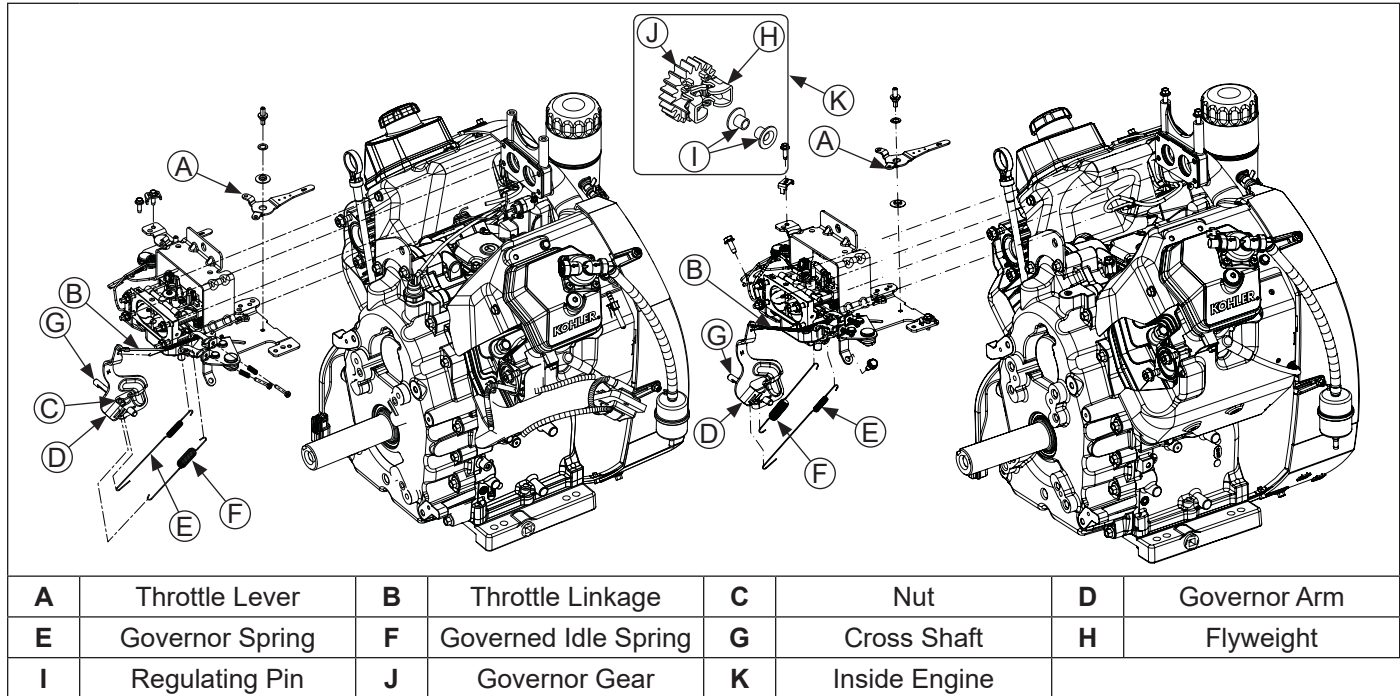

This governor design works as follows:

- Centrifugal force acting on rotating governor gear assembly causes flyweights to move outward as speed increases. Governor spring tension moves them inward as speed decreases.
- As flyweights move outward, they cause regulating pin to move outward.
- Regulating pin contacts tab on cross shaft causing shaft to rotate.
- One end of cross shaft protrudes through crankcase. Rotating action of cross shaft is transmitted to throttle lever of carburetor through external throttle linkage.
- When engine is at rest, and throttle is in fast position, tension of governor spring holds throttle plate open. When engine is operating, governor gear assembly is rotating. Force applied by regulating pin against cross shaft tends to close throttle plate. Governor spring tension and force applied by regulating pin balance each other during operation, to maintain engine speed.
- When load is applied and engine speed and governor gear speed decreases, governor spring tension moves governor arm to open throttle plate wider. This allows more fuel into engine, increasing engine speed. As speed reaches governed setting, governor spring tension and force applied by regulating pin will again offset each other to hold a steady engine speed.

### Governor Adjustments

**NOTE:** Do not tamper with governor setting. Overspeed is hazardous and could cause personal injury.

#### Initial Adjustment Procedure

Make this adjustment whenever governor arm is loosened or removed from cross shaft. Adjust as follows:

1. Make sure throttle linkage is connected to governor arm and throttle lever on carburetor.
2. Loosen nut holding governor lever to cross shaft.
3. Move governor lever toward carburetor as far as it will go (wide open throttle) and hold in this position.
4. Insert a long thin rod or tool into hole on cross shaft and rotate shaft clockwise (viewed from end) as far as it will turn, then torque nut to 7.1 N·m (63 in. lb.).

# Lubrication System

This engine uses a full pressure lubrication system which delivers oil under pressure to crankshaft, camshaft, connecting rod bearing surfaces, and hydraulic valve lifters.

A high-efficiency gerotor oil pump maintains high oil flow and oil pressure, even at low speeds and high operating temperatures. A pressure relief valve limits maximum pressure of system. Closure plate must be removed to service oil pickup, pressure relief valve, and oil pump.

## Lubrication Components

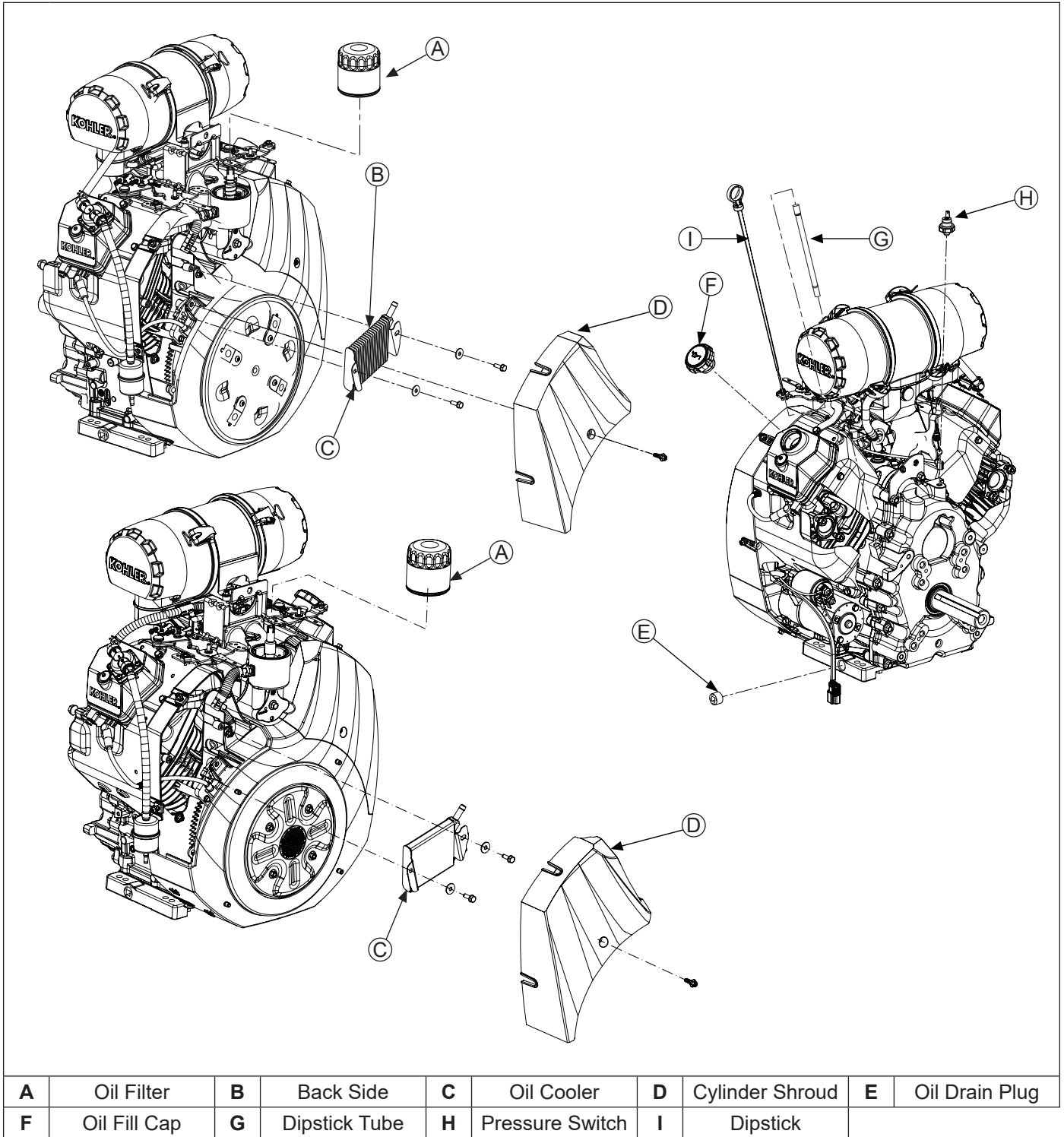

# Lubrication System

## OIL RECOMMENDATIONS

Refer to Maintenance.

### CHECK OIL LEVEL

NOTE: To prevent extensive engine wear or damage, never run engine with oil level below or above operating range indicator on dipstick.

Ensure engine is cool. Clean oil fill/dipstick areas of any debris.

1. Remove dipstick; wipe oil off.
2. Reinsert dipstick into tube; press completely down.
3. Remove dipstick; check oil level. Level should be at top of indicator on dipstick.
4. If oil is low on indicator, add oil up to top of indicator mark.
5. Reinstall and secure dipstick.

### CHANGE OIL AND FILTER

Change oil while engine is warm.

1. Clean area around oil fill cap/dipstick and drain plug. Remove drain plug and oil fill cap/dipstick. Allow oil to drain completely.
2. Clean area around oil filter; remove filter; wipe off mounting surface. Reinstall drain plug and torque to 21.4 N·m (16 ft. lb.).
3. Place new filter in shallow pan with open end up. Fill with new oil until oil reaches bottom of threads. Allow 2 minutes for oil to be absorbed by filter material.
4. Apply a thin film of clean oil to rubber gasket on new filter.
5. Refer to instructions on oil filter for proper installation.
6. Fill crankcase with new oil. Level should be at top of indicator on dipstick.
7. Reinstall oil fill cap/dipstick and tighten securely.
8. Start engine; check for oil leaks. Stop engine; correct leaks. Recheck oil level.
9. Dispose of used oil and filter in accordance with local ordinances.

## OIL COOLER

NOTE: Oil cooler is mounted under cylinder shroud. Removal of cylinder shroud is necessary to access oil cooler.

1. Clean fins with a brush or compressed air.
2. Remove screws securing oil cooler and tilt to clean back side.
3. Reinstall oil cooler and torque to 2.3 N·m (21 in. lb.).

### OIL SENTRY™ (if equipped)

This switch is designed to prevent engine from starting in a low oil or no oil condition. Oil Sentry™ may not shut down a running engine before damage occurs. In some applications this switch may activate a warning signal. Read your equipment manuals for more information.

Oil Sentry™ pressure switch is installed in closure plate pressure port. On engines not equipped with Oil Sentry™ installation hole is sealed with a 1/8-27 N.P.T.F. pipe plug.

### Installation

1. Apply pipe sealant with Teflon® (Loctite® PST® 592™ Thread Sealant or equivalent) to threads of switch.
2. Install switch into tapped hole in closure plate.
3. Torque switch to 10.7 N·m (95 in. lb.).

### Testing

Compressed air, a pressure regulator, pressure gauge, and a continuity tester are required to test switch.

1. Connect continuity tester across blade terminal and metal case of switch. With 0 psi pressure applied to switch, tester should indicate continuity (switch closed).
2. Gradually increase pressure to switch. As pressure increases through range of 7-11 psi tester should indicate a change to no continuity (switch open). Switch should remain open as pressure is increased to 90 psi maximum.
3. Gradually decrease pressure through range of 7-11 psi. Tester should indicate a change to continuity (switch closed) down to 0 psi.
4. Replace switch if it does not operate as specified.

## SPARK PLUGS



### ⚠ CAUTION

Electrical Shock can cause injury.  
Do not touch wires while engine is running.

### Spark Plug Component and Details

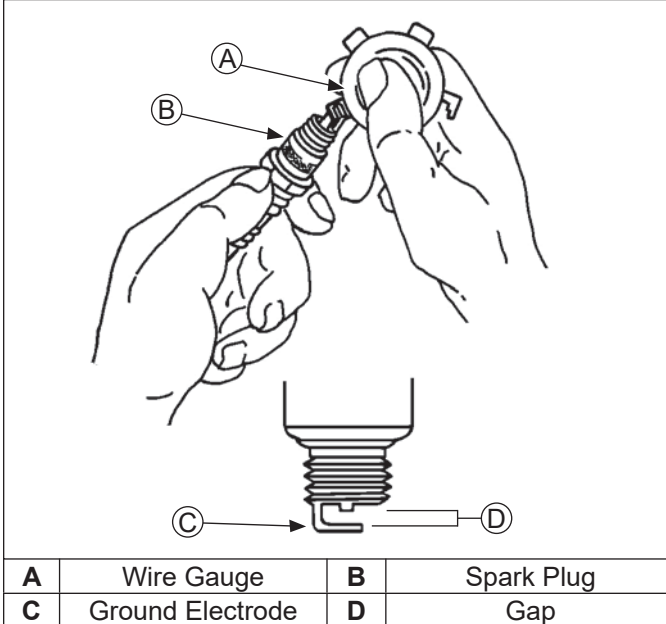

**NOTE:** Do not clean spark plug in a machine using abrasive grit. Some grit could remain in spark plug and enter engine causing extensive wear and damage.

Engine misfire or starting problems are often caused by a spark plug that has improper gap or is in poor condition.

Engine is equipped with following spark plugs:

Gap	0.76 mm (0.030 in.)
Thread Size	14 mm
Reach	19.1 mm (3/4 in.)
Hex Size	15.9 mm (5/8 in.)

Refer to Maintenance for Repairs/Service Parts.

### Service

Clean out spark plug recess. Remove plug and replace.

1. Check gap using wire feeler gauge. Adjust gap to 0.76 mm (0.030 in.).
2. Install plug into cylinder head.
3. Torque plug to 27 N·m (20 ft. lb.).

### Inspection

Inspect each spark plug as it is removed from cylinder head. Deposits on tip are an indication of general condition of piston rings, valves, and carburetor.

Normal and fouled plugs are shown in following photos:

#### Normal

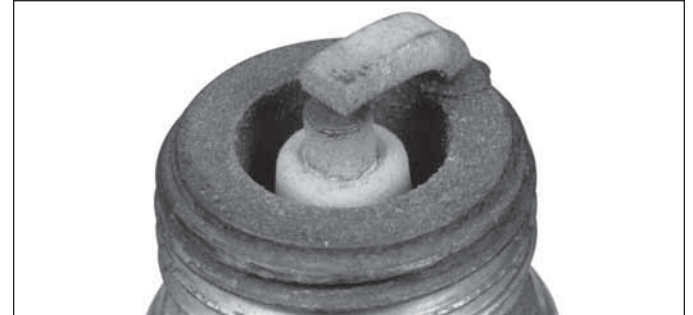

Plug taken from an engine operating under normal conditions will have light tan or gray colored deposits. If center electrode is not worn, plug can be set to proper gap and reused.

#### Worn



On a worn plug, center electrode will be rounded and gap will be greater than specified gap. Replace a worn spark plug immediately.

#### Wet Fouled



A wet plug is caused by excess fuel or oil in combustion chamber. Excess fuel could be caused by a restricted air cleaner, a carburetor problem, or operating engine with too much choke. Oil in combustion chamber is usually caused by a restricted air cleaner, a breather problem, worn piston rings, or valve guides.

# Electrical System

## Carbon Fouled



Soft, sooty, black deposits indicate incomplete combustion caused by a restricted air cleaner, over rich carburetion, weak ignition, or poor compression.

## Overheated



Chalky, white deposits indicate very high combustion temperatures. This condition is usually accompanied by excessive gap erosion. Lean carburetor settings, an intake air leak, or incorrect spark timing are normal causes for high combustion temperatures.

## BATTERY

A 12-volt battery with 400 cold cranking amps (cca) is generally recommended for starting in all conditions. A smaller capacity battery is often sufficient if an application is started only in warmer temperatures. Refer to following table for minimum capacities based on anticipated ambient temperatures. Actual cold cranking requirement depends on engine size, application, and starting temperatures. Cranking requirements increase as temperatures decrease and battery capacity shrinks. Refer to equipment's operating instructions for specific battery requirements.

### Battery Size Recommendations

Temperature	Battery Required
Above 32°F (0°C)	300 cca minimum
0°F to 32°F (-18°C to 0°C)	300 cca minimum
-5°F to 0°F (-21°C to -18°C)	300 cca minimum
-10°F (-23°C) or below	400 cca minimum

If battery charge is insufficient to turn over engine, recharge battery.

### Battery Maintenance

Regular maintenance is necessary to prolong battery life.

### Battery Test

To test battery, follow manufacturer's instructions.

## ELECTRONIC IGNITION SYSTEMS

### Ignition System Components

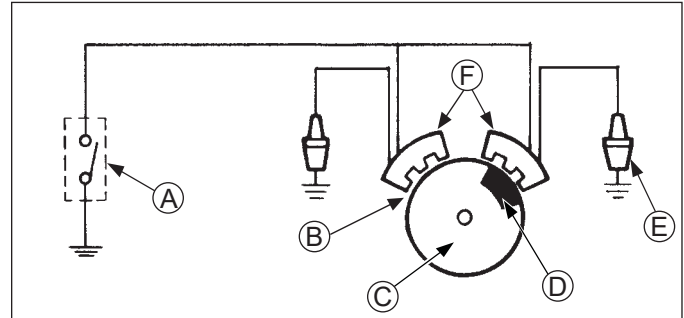

<b>A</b>	Kill Switch/ Off Position of Key Switch	<b>B</b>	Air Gap
<b>C</b>	Flywheel	<b>D</b>	Magnet
<b>E</b>	Spark Plug	<b>F</b>	Ignition Modules

There are 2 different types of ignition systems used on these engines. All systems use an ignition module which energizes spark plug. Difference in system is in way ignition timing is triggered.

Both ignition systems are designed to be trouble free for life of engine. Other than periodically checking/replacing spark plugs, no maintenance or timing adjustments are necessary or possible. Mechanical systems do occasionally fail or break down. Refer to Troubleshooting to determine root of a reported problem.

Reported ignition problems are most often due to poor connections. Before beginning test procedure, check all external wiring. Be certain all ignition-related wires are connected, including spark plug leads. Be certain all terminal connections fit snugly. Make sure ignition switch is in run position.

### CDI/MDI Ignition System

#### CDI/MDI Ignition Module Identification

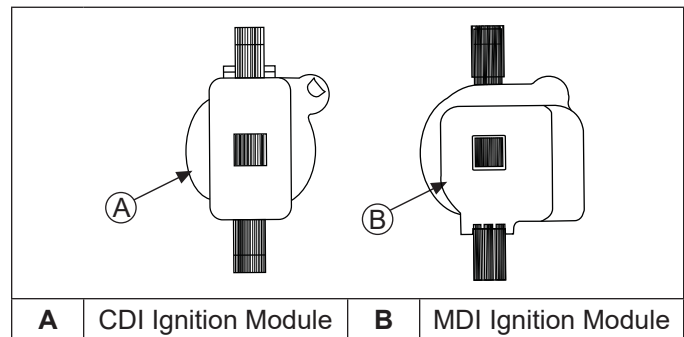

These systems use a capacitive discharge (CD) coil. With CDI fixed timing, ignition timing and spark remains constant regardless of engine speed. Timing of spark is controlled by location of flywheel magnet group as referenced to engine TDC. MDI adjustable timing uses a digital microprocessor which is located in ignition modules. Ignition timing varies depending upon engine speed with this system.

A typical fixed ignition system consists of:

- 1 magnet assembly which is permanently affixed to flywheel.
- 2 electronic capacitive-discharge (CDI) or magnetic discharge (MDI) ignition modules which mount on engine crankcase.
- 1 kill switch (or key switch) which grounds modules to stop engine.
- 2 spark plugs.

## Wire Diagram-15/20/25 Amp Regulated Battery Charging System with CDI/MDI, Four Pin Connector

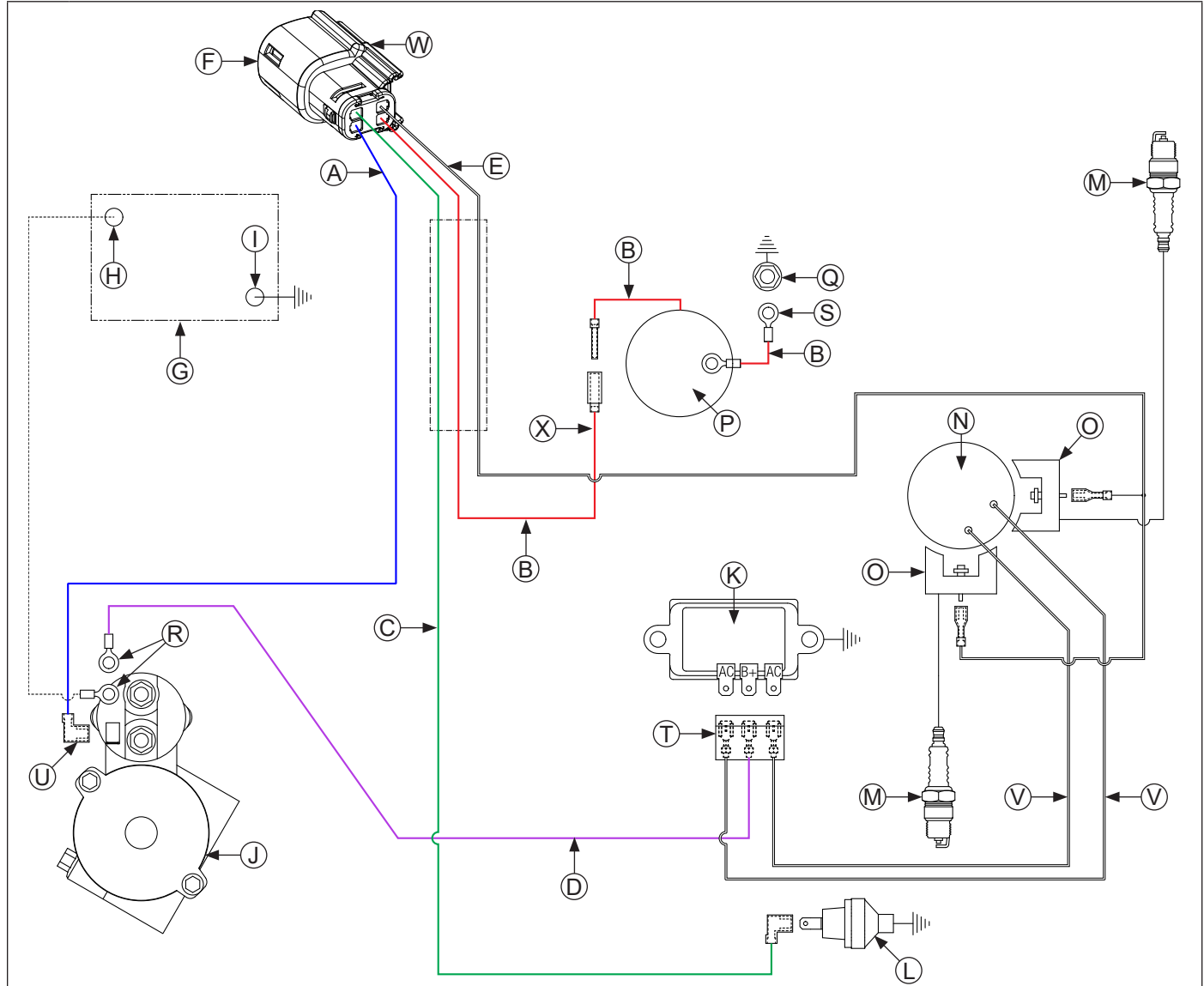

<b>A</b>	Blue	<b>B</b>	Red	<b>C</b>	Green	<b>D</b>	Violet (Charging)
<b>E</b>	White (Ignition Kill)	<b>F</b>	Connector	<b>G</b>	Battery	<b>H</b>	Battery Positive
<b>I</b>	Battery Negative	<b>J</b>	Starter	<b>K</b>	Rectifier-Regulator	<b>L</b>	Oil Sentry™
<b>M</b>	Spark Plug(s)	<b>N</b>	Flywheel Stator Assembly	<b>O</b>	Ignition Module(s)	<b>P</b>	Carburetor
<b>Q</b>	Intake Manifold Screw	<b>R</b>	Starter Solenoid Stud	<b>S</b>	Ground	<b>T</b>	Rectifier-Regulator Connector
<b>U</b>	Starter Solenoid Tang	<b>V</b>	White (AC Charging Leads)	<b>W</b>	Polarity Ribs	<b>X</b>	Solenoid Lead

# Electrical System

## Wire Diagram-15/20/25 Amp Regulated Battery Charging System with CDI/MDI, Five Pin Connector, Key Switch, and Fuse

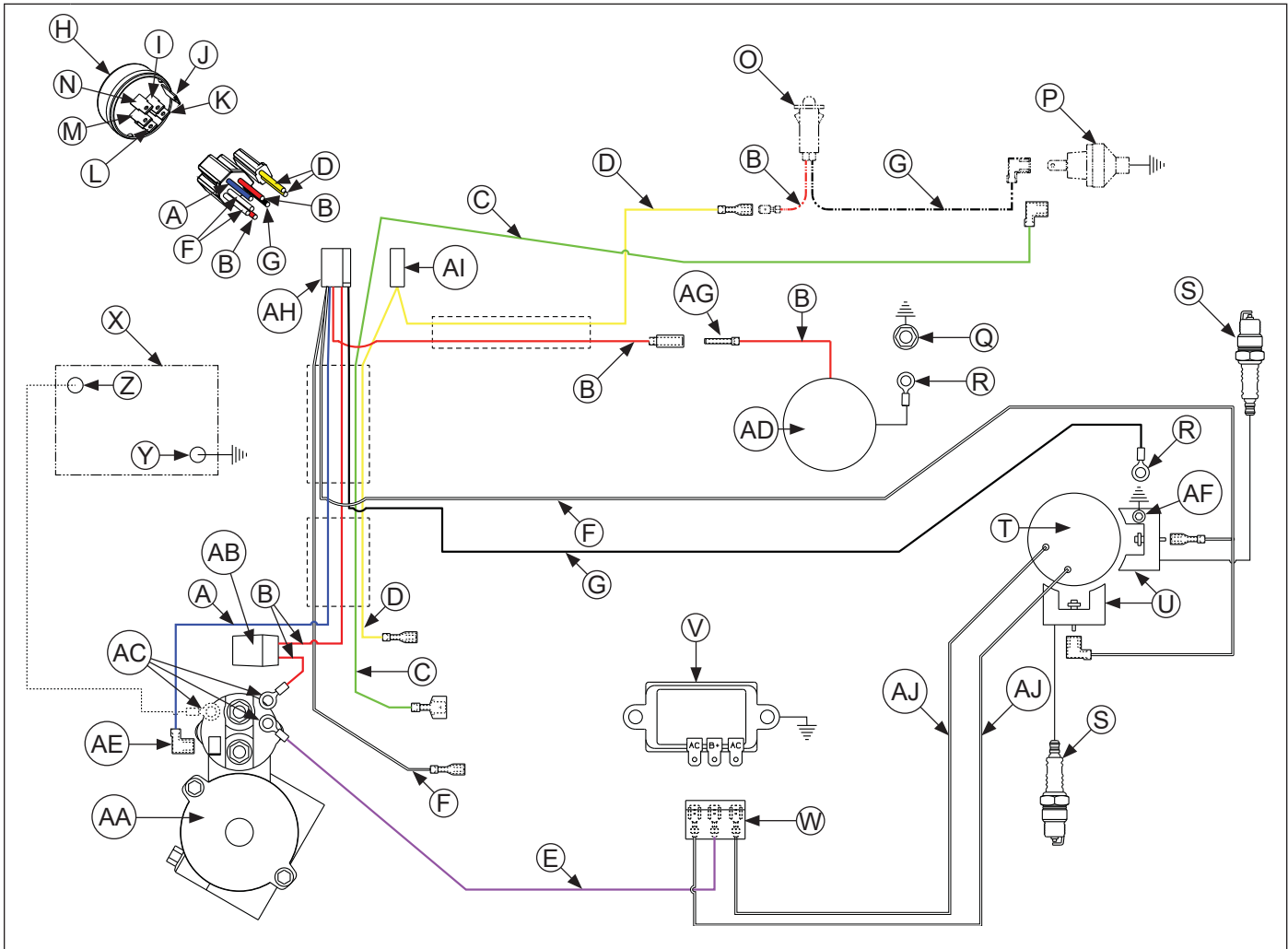

<b>A</b>	Blue	<b>B</b>	Red	<b>C</b>	Green (Oil Sentry™ Pulse Signal) <sup>8</sup>	<b>D</b>	Yellow
<b>E</b>	Violet	<b>F</b>	White	<b>G</b>	Black	<b>H</b>	Key Switch
<b>I</b>	To Battery	<b>J</b>	To Accessory	<b>K</b>	Ground	<b>L</b>	To Rectifier-Regulator
<b>M</b>	To Magneto	<b>N</b>	To Starter	<b>O</b>	Oil Sentry™ Light (Optional)	<b>P</b>	Oil Sentry™
<b>Q</b>	Carburetor Mounting Stud	<b>R</b>	Ground	<b>S</b>	Spark Plug(s)	<b>T</b>	Flywheel Stator Assembly
<b>U</b>	Ignition Module(s)	<b>V</b>	Rectifier-Regulator	<b>W</b>	Rectifier-Regulator Connector	<b>X</b>	Battery
<b>Y</b>	Battery Negative	<b>Z</b>	Battery Positive	<b>AA</b>	Starter	<b>AB</b>	Fuse
<b>AC</b>	Starter Solenoid Stud	<b>AD</b>	Carburetor	<b>AE</b>	Starter Solenoid Tang	<b>AF</b>	Ignition Module Mounting Screw
<b>AG</b>	Solenoid Lead	<b>AH</b>	Connector (5-Circuit)	<b>AI</b>	Connector (1-Circuit)	<b>AJ</b>	White (AC Charging Leads)

<sup>8</sup> Not valid with indicator light or no pressure switch.

## Digital Spark Advance Ignition (DSAI) System

This system uses a digital microprocessor which is located in ignition modules. Ignition timing varies depending upon engine speed with this system. There are 2 inductive-style ignition modules that control ignition timing based on engine RPM. A typical DSAI application consists of:

- 1 magnet assembly, which is permanently affixed to flywheel.
- 2 inductive, 12-volt ignition modules, which mount on engine crankcase.
- 1 12-volt battery, which supplies current to ignition modules.
- 1 kill switch (or key switch) which grounds spark advance module to stop engine.
- 2 spark plugs.

### Wire Diagram-15/20/25 Amp Regulated Battery Charging System with DSAI Ignition, Five Pin Connector and Key Switch

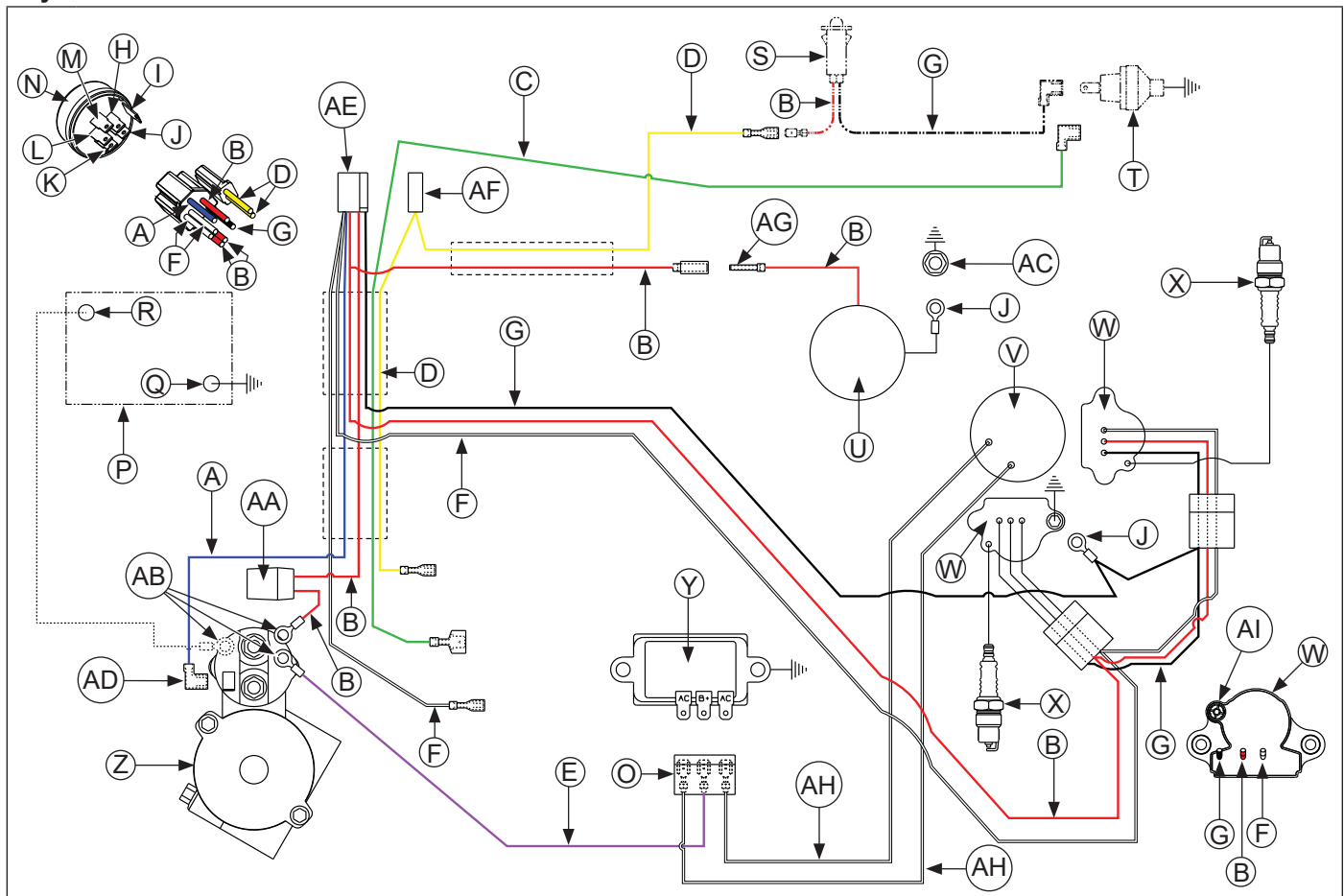

<b>A</b>	Blue	<b>B</b>	Red	<b>C</b>	Green (Oil Sentry™ Pulse Signal) <sup>8</sup>	<b>D</b>	Yellow (Accessory)
<b>E</b>	Violet	<b>F</b>	White	<b>G</b>	Black	<b>H</b>	To Battery
<b>I</b>	To Accessory	<b>J</b>	Ground	<b>K</b>	To Rectifier-Regulator	<b>L</b>	To Magneto
<b>M</b>	To Starter	<b>N</b>	Key Switch	<b>O</b>	Rectifier-Regulator Connector	<b>P</b>	Battery
<b>Q</b>	Battery Negative	<b>R</b>	Battery Positive	<b>S</b>	Oil Sentry™ Light (Optional)	<b>T</b>	Oil Sentry™
<b>U</b>	Carburetor	<b>V</b>	Flywheel Stator Assembly	<b>W</b>	Ignition Module(s)	<b>X</b>	Spark Plug(s)
<b>Y</b>	Rectifier-Regulator	<b>Z</b>	Starter	<b>AA</b>	Fuse	<b>AB</b>	Starter Solenoid Stud
<b>AC</b>	Carburetor Mounting Stud	<b>AD</b>	Starter Solenoid Tang	<b>AE</b>	Connector (5-Circuit)	<b>AF</b>	Connector (1-Circuit)
<b>AG</b>	Solenoid Lead	<b>AH</b>	White (AC Charging Leads)	<b>AI</b>	Spark Plug Lead		

<sup>8</sup> Not valid with indicator light or no pressure switch.

# Electrical System

Wire Diagram-15/20/25 Amp Regulated Battery Charging System with DSAI Ignition and Four Pin Connector (LP-NG Rehlko Power Systems Application)

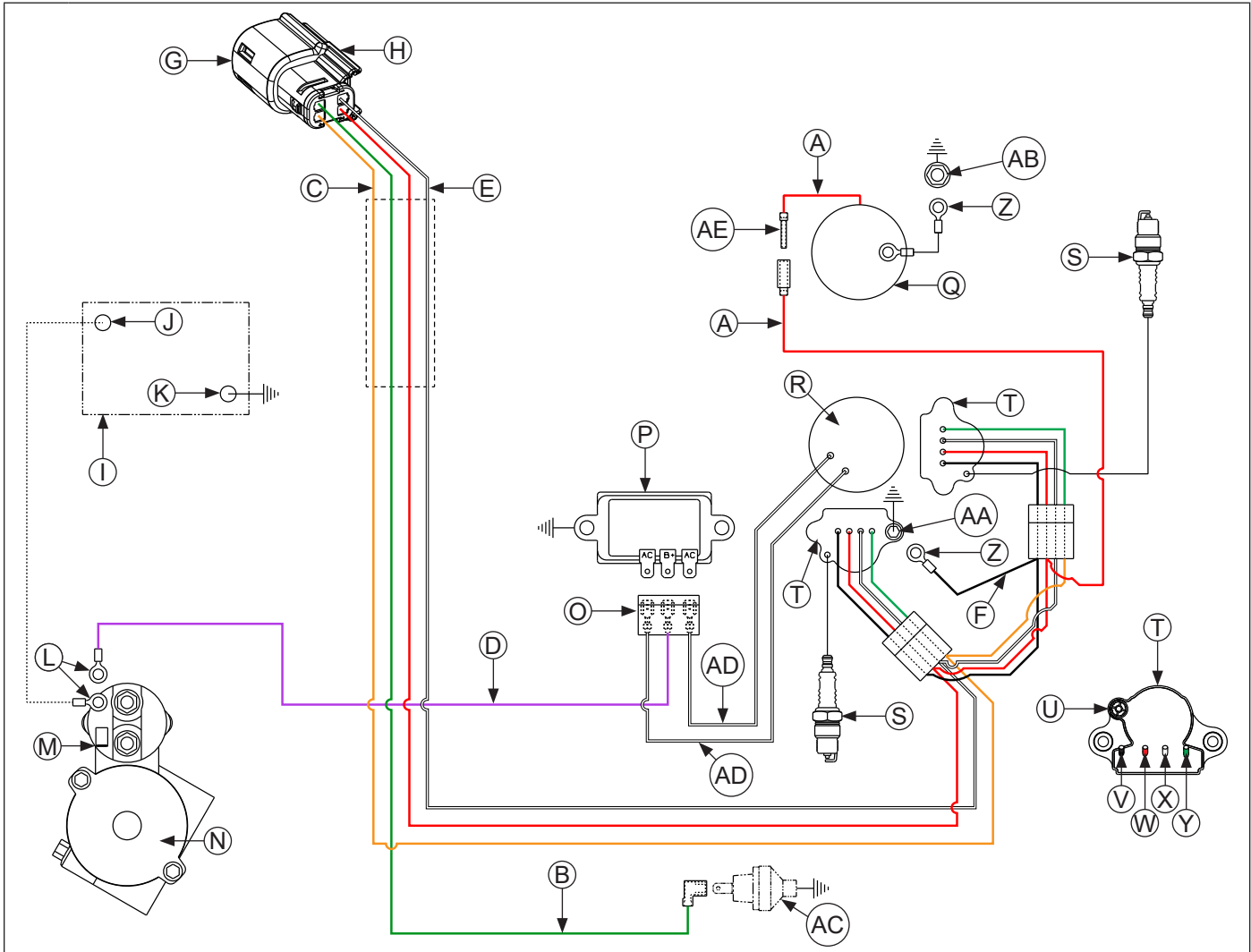

<b>A</b>	Red	<b>B</b>	Green	<b>C</b>	Orange	<b>D</b>	Violet
<b>E</b>	White	<b>F</b>	Black	<b>G</b>	Connector	<b>H</b>	Polarity Ribs
<b>I</b>	Battery	<b>J</b>	Battery Positive	<b>K</b>	Battery Negative	<b>L</b>	Starter Solenoid Stud
<b>M</b>	External Starter Solenoid Wire	<b>N</b>	Starter	<b>O</b>	Rectifier-Regulator Connector	<b>P</b>	Rectifier-Regulator
<b>Q</b>	Carburetor	<b>R</b>	Flywheel Stator Assembly	<b>S</b>	Spark Plug(s)	<b>T</b>	Ignition Module(s)
<b>U</b>	Spark Plug Lead	<b>V</b>	Black (Ground)	<b>W</b>	Red (B+)	<b>X</b>	White (Shut Off)
<b>Y</b>	Green (LP/NG Switch)	<b>Z</b>	Ground	<b>AA</b>	Module Mounting Screw	<b>AB</b>	Carburetor Mounting Stud
<b>AC</b>	Oil Sentry™	<b>AD</b>	White (AC Charging Leads)	<b>AE</b>	Solenoid Lead		

**Wire Diagram-15/20/25 Amp Regulated Battery Charging System with DSAI Ignition and Five Pin Connector (Gasoline/LP-NG Non-Rehiko Power Systems Application)**

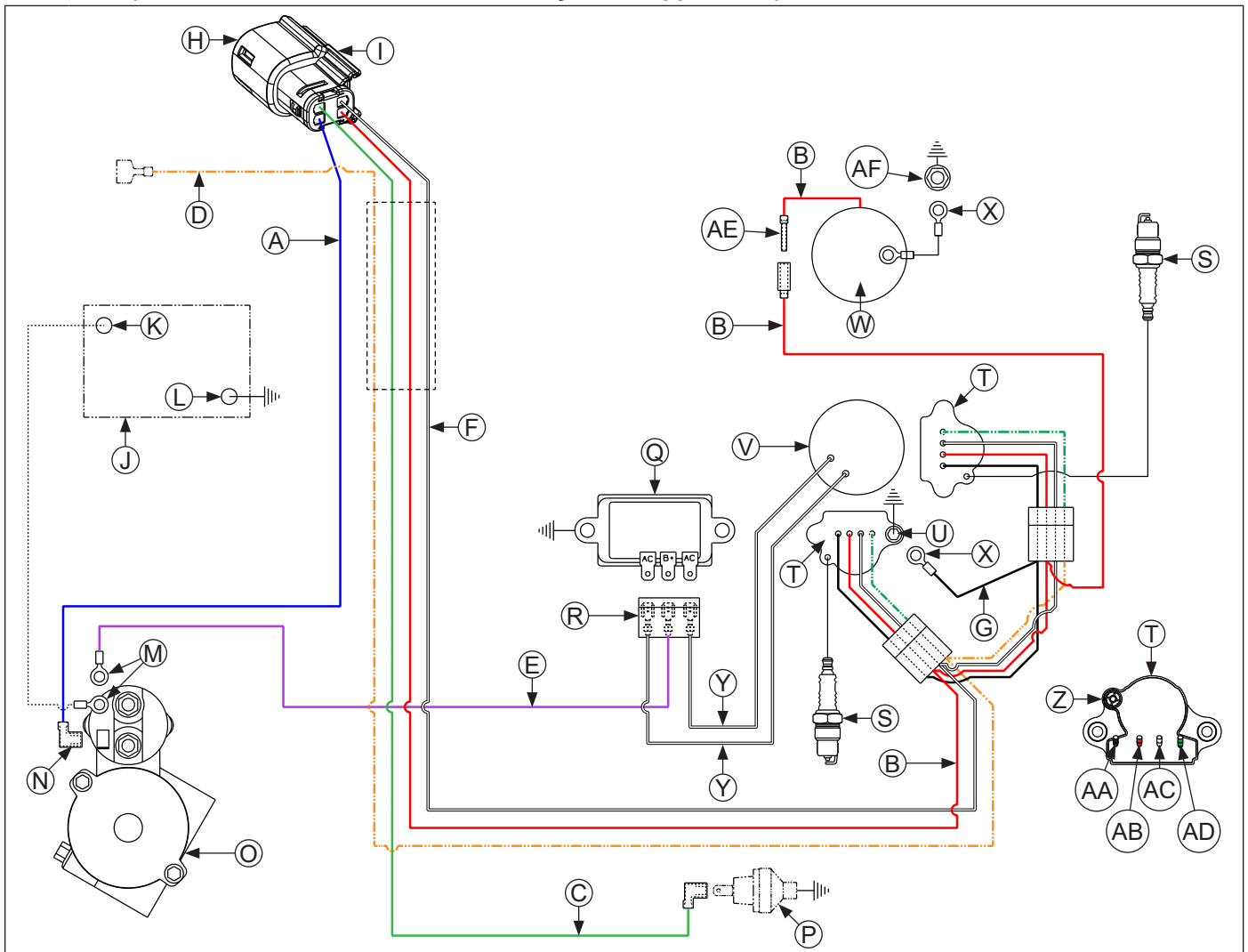

<b>A</b>	Blue	<b>B</b>	Red	<b>C</b>	Green	<b>D</b>	Orange
<b>E</b>	Violet	<b>F</b>	White	<b>G</b>	Black	<b>H</b>	Connector
<b>I</b>	Polarity Ribs	<b>J</b>	Battery	<b>K</b>	Battery Positive	<b>L</b>	Battery Negative
<b>M</b>	Starter Solenoid Stud	<b>N</b>	Starter Solenoid Tang	<b>O</b>	Starter	<b>P</b>	Oil Sentry™
<b>Q</b>	Rectifier-Regulator	<b>R</b>	Rectifier-Regulator Connector	<b>S</b>	Spark Plug(s)	<b>T</b>	Ignition Module(s)
<b>U</b>	Module Mounting Screw	<b>V</b>	Flywheel Stator Assembly	<b>W</b>	Carburetor	<b>X</b>	Ground
<b>Y</b>	White (AC Charging Leads)	<b>Z</b>	Spark Plug Lead	<b>AA</b>	Black (Ground)	<b>AB</b>	Red (B+)
<b>AC</b>	White (Shut Off)	<b>AD</b>	Green (LP/NG Switch)	<b>AE</b>	Solenoid Lead	<b>AF</b>	Carburetor Mounting Stud

# Electrical System

## Electronic Ignition Systems Tests

NOTE: Ignition tester must be used to test ignition on these engines. Use of any other tester can result in inaccurate findings. Battery on unit must be fully charged and properly connected before performing tests (a battery that is hooked up or charged backward will crank engine but it won't have spark). Be certain drive is in neutral and all external loads are disconnected.

### Special Tools Required:

- Hand tachometer.
- Ignition tester.
- Automotive timing light.
- Multi-meter (digital).

### Specifications Required:

- 0.76 mm (0.03 in.).

### Test Ignition Systems

NOTE: If engine starts or runs during testing, you may need to ground kill lead to shut it down. Because you have interrupted kill circuit, it may not stop using switch.

Isolate and verify trouble is within engine.

1. Locate connectors where wiring harnesses from engine and equipment are joined. Separate connectors and remove white kill lead from engine connector. Rejoin connectors and position or insulate kill lead terminal so it cannot touch ground. Try to start engine to verify whether reported problem is still present.

Condition	Possible Cause	Conclusion
Problem goes away.	Electrical System	Check key switch, wires, connections, safety interlocks, etc.
Problem persists.	Ignition or Electrical System	Leave kill lead isolated until all testing is completed. Identify white kill lead of engine wiring harness connector. Establish a connection to a known good ground location. Engine should kill completely. If not or only one cylinder is affected, test ignition modules and white kill lead connection for affected DSAI module (DSAI only).

### Test for Spark

NOTE: If 2 testers are available, testing can be performed simultaneously for both cylinders. However, if only 1 tester is available, 2 individual tests must be performed. Side not being tested must have spark plug lead connected or grounded. Do not crank engine or perform tests with 1 spark plug lead disconnected and not grounded, or permanent system damage may occur.

1. With engine stopped, disconnect 1 spark plug lead. Connect spark plug lead to post terminal of spark tester and attach tester clip to a good engine ground.
2. Crank engine over, establishing a minimum of 350-450 RPM, and observe tester(s) for spark.
3. Repeat spark test on opposite cylinder if cylinders are being tested individually.

Condition	Possible Cause	Conclusion
Both cylinders have good spark but engine runs poorly or existing plug condition is questionable.	Spark Plug(s)	Install new spark plug(s) and retest engine performance. If problem persists, check for timing advance (DSAI only).
1 cylinder has good spark and other cylinder has no or intermittent spark.	Ignition	Test ignition modules and connections.
Spark on both cylinders but power is suspect.	Timing Advance Sheared Flywheel Key	Check for timing advance (DSAI only). Check for broken key.

## Check Ignition Modules and Connections (CDI/MDI only)

1. Remove blower housing from engine. Inspect kill wire for any damage, cuts, or shorts to engine or ignition module body. Check that connections are oriented properly on terminals of modules.
2. On MDI adjustable timing engines, ensure that both modules are correctly installed with flat side of module out/ towards you.

Condition	Possible Cause	Conclusion
All checks are OK but module has no spark or fails to advance.	Ignition Module	Replace affected module.

## Test Timing Advance (DSAI only)

1. Make a line near edge of flywheel screen with a marking pen, chalk, or narrow tape.
2. Connect an automotive timing light to cylinder that had good spark.
3. Run engine at idle and use timing light beam to locate line on screen. Draw a line on blower housing next to line on screen. Accelerate to full throttle and watch for movement of line on screen relative to line on blower housing. If both cylinders had good spark, repeat test on other cylinder.

Condition	Possible Cause	Conclusion
Line on screen did not move away from line on blower housing during acceleration.	Ignition	Test ignition modules and connections.
Lines made on blower housing not 90° apart.		

## Test Ignition Modules and Connections (DSAI only)

1. Remove blower housing from engine. Inspect wiring for any damage, cuts, bad crimps, loose terminals, or broken wires. Check that connections are oriented properly on terminals of modules.
2. Disconnect leads from ignition module(s) and clean all of terminals (male and female) with aerosol electrical contact cleaner to remove any old dielectric compound, dark residue, dirt, or contamination. Disconnect spark plug leads from spark plugs.
3. Using a multi-meter, check that a proper ground is established between ground (black) lead of DSAI module (closest to spark plug lead) and a known good ground location on engine.
4. Turn key switch to ON position and check for 12 volts at center/power (red) lead terminal of DSAI module. Use same ground location for multi-meter as in checking for timing advance.

Condition	Possible Cause	Conclusion
All tests are OK but module has no spark or fails to advance.	Ignition Module	Replace affected module.
Any test is BAD.	Ignition Module or Connections	Determine cause and fix as required; retest.

# Electrical System

## BATTERY CHARGING SYSTEM

NOTE: Observe following guidelines to avoid damage to electrical system and components:

- Make sure battery polarity is correct. A negative (–) ground system is used.
- Disconnect rectifier-regulator plug and/or wiring harness plug before doing any electric welding on equipment powered by engine. Disconnect all other electrical accessories in common ground with engine.
- Prevent stator (AC) leads from touching or shorting while engine is running. This could damage stator.

NOTE: 20 amp charging systems use a 15 amp stator with a 25 amp rectifier-regulator.

Most engines are equipped with a 15, 20, or 25 amp regulated charging system.

### 15/20/25 Amp Regulated Charging System

#### Stator

Stator is mounted on crankcase behind flywheel. Follow procedures in Disassembly and Reassembly if stator replacement is necessary.

#### Rectifier-Regulator

NOTE: When installing rectifier-regulator, take note of terminal positions and install plug correctly.

NOTE: Disconnect all electrical connections attached to rectifier-regulator. Testing may be performed with rectifier-regulator mounted or loose. Repeat applicable test procedure 2 or 3 times to determine condition of part.

Rectifier-regulator is mounted on backing shroud assembly. To replace it, disconnect plug, remove mounting screws, and ground lead.

Testing rectifier-regulator may be performed as follows, using appropriate rectifier-regulator tester.

To test 20/25 amp rectifier-regulators:

1. Connect single lead adapter in between B+ (center) terminal of rectifier-regulator being tested and squared single end of tandem adapter lead.
2. Connect tester ground lead (with spring clamp) to body of rectifier-regulator.
3. Connect red lead and 1 black lead to terminals on open end of tandem adapter lead (connections are not location specific).
4. Connect remaining black lead from tester to 1 outer AC terminal on rectifier-regulator.
5. Plug tester into proper AC outlet/power for tester being used. Turn on power switch. POWER light should be illuminated and 1 of 4 status lights may be on as well. This does not represent condition of part.
6. Press TEST button until a click is heard and then release. Momentarily 1 of 4 lights will illuminate indicating partial condition of part.

To test 15 amp rectifier-regulators:

1. Connect tester ground lead (with spring clamp) to body of rectifier-regulator being tested.
2. Connect tester red lead to B+ terminal of rectifier-regulator and 2 black tester leads to 2 AC terminals.
3. Plug tester into proper AC outlet/power for tester being used. Turn on power switch. POWER light should be illuminated and 1 of 4 status lights may be on as well. This does not represent condition of part.
4. Press TEST button until a click is heard and then release. Momentarily 1 of 4 status lights will illuminate indicating condition of part.

Condition	Conclusion	
	20/25 amp	15 amp
OK (green) light comes on and stays steady.	Disconnect tester black lead attached to 1 AC terminal and reconnect it to other AC terminal. Repeat test. If OK (green) light comes on again, part is good and may be used.	Part is good and may be used.
NOTE: A flashing LOW light can also occur as a result of an inadequate ground lead connection. Make certain connection location is clean and clamp is secure. Other lights come on.	Rectifier-regulator is faulty and should not be used.	

## 15/20/25 Amp Battery Charging Systems

NOTE: Always zero ohmmeter on each scale before testing to ensure accurate readings. Voltage tests should be made with engine running at 3600 RPM with no load. Battery must be good and fully charged.

When problems occur in keeping battery charged or battery charges at high rate, charging system or battery might be causing problems.

To test charging system for no charge to battery:

1. Insert an ammeter in B+ lead from rectifier-regulator. With engine running at 3600 RPM and B+ (at terminal on rectifier-regulator) to ground using a DC voltmeter.

If voltage is 13.8 volts or more, place a minimum load of 5 amps (turn on lights if 60 watts or more, or place a 2.5 ohm, 100 watt resistor across battery terminals) on battery to reduce voltage. Observe ammeter.

Condition	Conclusion
Charge rate increases when load is applied.	Charging system is OK and battery was fully charged.
Charge rate does not increase when load is applied.	Test stator and rectifier-regulator (steps 2 and 3).

2. Remove connector from rectifier-regulator. With engine running at 3600 RPM, measure AC voltage across stator leads using an AC voltmeter.

Condition	Conclusion
Voltage is 28 volts or more.	Stator is OK. Rectifier-regulator is faulty; replace.
Voltage is less than 28 volts.	Stator is faulty; replace. Test stator further using an ohmmeter (steps 3 and 4).

3. With engine stopped, measure resistance across stator leads using an ohmmeter.

Condition	Conclusion
Resistance is 0.1/0.2 ohms.	Stator is OK.
Resistance is 0 ohms.	Stator is shorted; replace.
Resistance is infinity ohms.	Stator is open; replace.

4. With engine stopped, measure resistance from each stator lead to ground using an ohmmeter.

Condition	Conclusion
Resistance is infinity ohms (no continuity).	Stator is OK (not shorted to ground).
Resistance (or continuity) measured.	Stator leads are shorted to ground; replace.

To test charging system for battery continuously charging at high rate:

1. With engine running at 3600 RPM, measure voltage from B+ lead to ground using a DC voltmeter.

Condition	Conclusion
Voltage is 14.7 volts or less.	Charging system is OK. Battery is unable to hold charge; service or replace.
Voltage is more than 14.7 volts.	Faulty rectifier-regulator; replace.

# Starter System

## ELECTRIC STARTING MOTOR

NOTE: Do not crank engine continuously for more than 10 seconds. Allow a 60 second cool down period between starting attempts. Failure to follow these guidelines can burn out starter motor.

NOTE: If engine develops sufficient speed to disengage starter but does not keep running (a false start), engine rotation must be allowed to come to a complete stop before attempting to restart engine. If starter is engaged while flywheel is rotating, starter pinion and flywheel ring gear may clash and damage starter.

NOTE: If starter does not crank engine, shut off starter immediately. Do not make further attempts to start engine until condition is corrected.

NOTE: Do not drop starter or strike starter frame. Doing so can damage starter.

Engines in this series use solenoid shift starters.

### Operation-Solenoid Shift Starter

When power is applied to starter electric solenoid moves drive pinion out onto drive shaft and into mesh with flywheel ring gear. When pinion reaches end of drive shaft it rotates flywheel and cranks engine.

When engine starts and start switch is released, starter solenoid is deactivated, drive lever moves back, and drive pinion moves out of mesh with ring gear into retracted position.

### Troubleshooting-Starting Difficulties

Condition	Possible Cause	Conclusion
Starter does not energize.	Battery	Check specific gravity of battery. If low, recharge or replace battery as necessary.
	Wiring	Clean corroded connections and tighten loose connections. Replace wires in poor condition and with frayed or broken insulation.
	Starter Switch or Solenoid	By-pass switch or solenoid with a jumper wire. If starter cranks normally, replace faulty components. Remove and perform individual solenoid test procedure.
Starter energizes but turns slowly.	Battery	Check specific gravity of battery. If low, recharge or replace battery as necessary.
	Brushes	Check for excessively dirty or worn brushes and commutator. Clean using a coarse cloth (not emery cloth). Replace brushes if excessively or unevenly worn.
	Transmission or Engine	Make sure clutch or transmission is disengaged or placed in neutral. This is especially important on equipment with hydrostatic drive. Transmission must be exactly in neutral to prevent resistance which could keep engine from starting. Check for seized engine components such as bearings, connecting rod, and piston.

## Solenoid Shift Starter Components

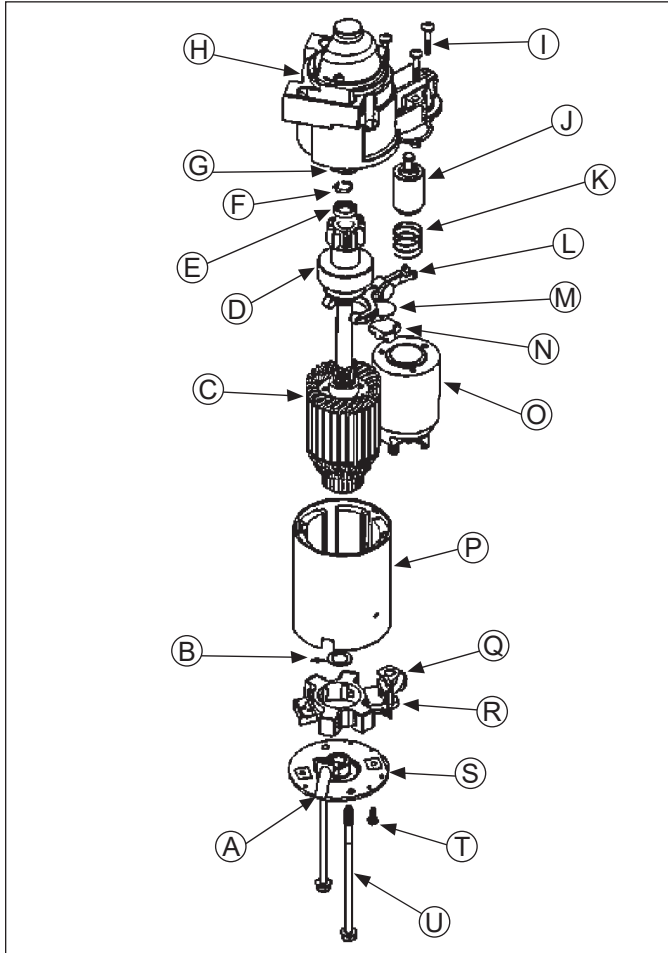

<b>A</b>	Tube	<b>B</b>	Washer
<b>C</b>	Armature	<b>D</b>	Drive
<b>E</b>	Stop	<b>F</b>	Retaining Ring
<b>G</b>	Collar	<b>H</b>	Drive End Cap
<b>I</b>	Screw	<b>J</b>	Plunger
<b>K</b>	Spring	<b>L</b>	Lever
<b>M</b>	Plate	<b>N</b>	Plug
<b>O</b>	Solenoid	<b>P</b>	Frame and Field
<b>Q</b>	Brush Holder	<b>R</b>	Nut
<b>S</b>	Commutator End Plate	<b>T</b>	Screw
<b>U</b>	Bolt		

### Starter Disassembly

NOTE: Do not reuse old retainer.

NOTE: Do not soak armature or use solvent when cleaning. Wipe clean using a soft cloth, or use compressed air.

1. Remove hex nut and disconnect positive (+) brush lead/bracket from solenoid terminal.
2. Remove screws securing solenoid to starter.
3. Unhook plunger pin from drive lever. Remove gasket from recess in housing.
4. Remove thru (larger) bolts.

5. Remove commutator end plate assembly, containing brush holder, brushes, springs, and locking caps. Remove thrust washer from inside commutator end.
6. Remove frame from armature and drive end cap.
7. Remove drive lever pivot bushing and backing plate (if equipped) from end cap.
8. Take out drive lever and pull armature out of drive end cap.
9. Remove thrust washer from armature shaft.
10. Push stop collar down to expose retaining ring.
11. Remove retainer from armature shaft. Save stop collar.
12. Remove drive pinion assembly from armature.
13. Clean parts as required.

### Inspection

#### Drive Pinion

Check and inspect following areas:

- Pinion teeth for abnormal wear or damage.
- Surface between pinion and clutch mechanism for nicks or irregularities which could cause seal damage.
- Check drive clutch by holding clutch housing and rotating pinion. Pinion should rotate in only 1 direction.

#### Brushes and Springs

##### Detail

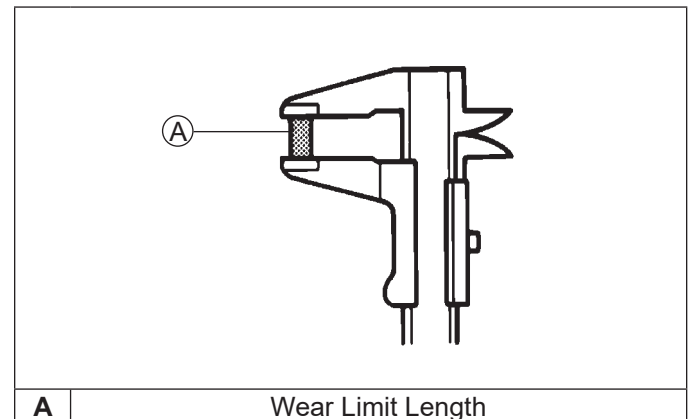

Inspect both springs and brushes for wear, fatigue, or damage. Measure length of each brush. Minimum length for each brush is 7.6 mm (0.300 in.). Replace brushes if they are worn, undersize, or condition is questionable.

#### Armature

##### Components and Details

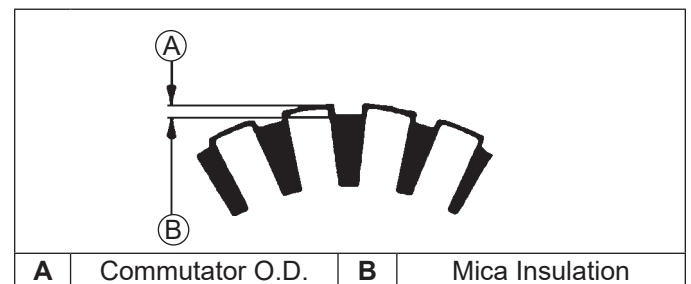

# Starter System

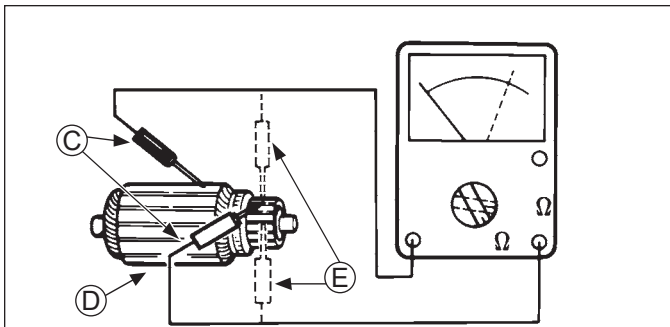

<b>C</b>	Insulation Check	<b>D</b>	Armature Coil
<b>E</b>	Continuity Check		

1. Clean and inspect commutator (outer surface). Mica insulation must be lower than commutator bars (undercut) to ensure proper operation of commutator.
2. Use an ohmmeter set to Rx1 scale. Touch probes between 2 different segments of commutator, and check for continuity. Test all segments. Continuity must exist between all or armature is bad.
3. Check for continuity between armature coil segments and commutator segments. There should be no continuity. If continuity exists between any 2 armature is bad.
4. Check armature windings/insulation for shorting.

## Shift Fork

Check that shift fork is complete, and pivot and contact areas are not excessively worn, cracked, or broken.

## Brush Replacement

4 brushes and springs are serviced as a set. Use a new Rehlko brush and spring kit if replacement is necessary.

1. Perform steps 1-5 in Starter Disassembly.
2. Remove screws securing brush holder assembly to end cap (plate). Note orientation for reassembly later. Discard old brush holder assembly.
3. Clean component parts as required.  
New brushes and springs come preassembled in a brush holder with a protective sleeve that will also serve as an installation tool.
4. Perform steps 10-13 in Starter Reassembly sequence. If starter has been disassembled, installation must be done after armature, drive lever, and frame are installed.

## Starter Reassembly

**NOTE:** Always use a new retainer. Do not reuse old retainers that have been removed.

**NOTE:** Correctly installed, center pivot section of drive lever will be flush or below machined surface of housing.

1. Apply drive lubricant to armature shaft splines. Install drive pinion onto armature shaft.
2. Install and assemble stop collar/retainer assembly.
  - a. Install stop collar down onto armature shaft with counter bore (recess) up.

- b. Install a new retainer in larger (rear) groove of armature shaft. Squeeze with a pliers to compress it in groove.
- c. Slide stop collar up and lock it into place, so recess surrounds retainer in groove. If necessary, rotate pinion outward on armature splines against retainer to help seat collar around retainer.

3. Install offset thrust (stop) washer so smaller offset of washer faces retainer/collar.
4. Apply a small amount of oil to bearing in drive end cap, and install armature with drive pinion.
5. Lubricate fork end and center pivot of drive lever with drive lubricant. Position fork end into space between captured washer and rear of pinion.
6. Slide armature into drive end cap and at same time seat drive lever into housing.
7. Install rubber grommet into matching recess of drive end cap. Molded recesses in grommet should be out, matching and aligned with those in end cap.
8. Install frame, with small notch forward, onto armature and drive end cap. Align notch with corresponding section in rubber grommet. Install drain tube in rear cutout, if it was removed previously.
9. Install flat thrust washer onto commutator end of armature shaft.
10. Starter reassembly when replacing brushes/brush holder assembly:

- a. Hold starter assembly vertically on end housing, and carefully position assembled brush holder assembly, with supplied protective tube, against end of commutator/armature. Mounting screw holes in metal clips must be up/out. Slide brush holder assembly down into place around commutator, and install positive (+) brush lead grommet in cutout of frame. Protective tube may be saved and used for future servicing.

Starter reassembly when not replacing brushes/brush holder assembly:

- a. Carefully unhook retaining caps from brush assemblies. Do not lose springs.
  - b. Position brushes back in their slots so they are flush with I.D. of brush holder assembly. Insert brush installation tool (with extension), or use tube described above from a prior brush installation, through brush holder assembly, so holes in metal mounting clips are up/out.
  - c. Install brush springs and snap on retainer caps.
  - d. Hold starter assembly vertically on end housing, and carefully place tool (with extension) and assembled original brush holder assembly onto end of armature shaft. Slide brush holder assembly down into place around commutator, install positive (+) brush lead grommet in cutout of frame.
11. Install end cap onto armature and frame, aligning thin raised rib in end cap with corresponding slot in grommet of positive (+) brush lead.

12. Install thru bolts and brush holder mounting screws. Torque bolts to 5.6-9.0 N·m (49-79 in. lb.) and brush holder mounting screws to 2.5-3.3 N·m (22-29 in. lb.).
13. Hook plunger behind upper end of drive lever and install spring into solenoid. Insert mounting screws through holes in drive end cap. Use these to hold solenoid gasket in position, then mount solenoid. Torque screws to 4.0-6.0 N·m (35-53 in. lb.).
14. Connect positive (+) brush lead/bracket to solenoid and secure with nut. Torque nut to 8-11 N·m (71-97 in. lb.). Do not overtighten.

## Solenoid Tests

NOTE: DO NOT leave 12 volt test leads connected to solenoid for any time over what is necessary for performing each of individual tests. Internal damage to solenoid may occur.

Disconnect all leads from solenoid including positive brush lead attached to lower stud terminal. Remove mounting hardware and separate solenoid from starter for testing.

To test solenoid pull-in coil/plunger:

### Actuation

1. Use a 12 volt power supply and 2 test leads.
2. Connect 1 lead to flat spade S/start terminal on solenoid. Momentarily connect other lead to lower large post terminal.  
When connection is made solenoid should energize (audible click) and plunger retract. Repeat test several times.

### Continuity

1. Use an ohmmeter set to audible or Rx2K scale, and connect 2 ohmmeter leads to 2 large post terminals.
2. Perform solenoid pull-in coil/plunger actuation test and check for continuity. Ohmmeter should indicate continuity. Repeat test several times.

To test solenoid hold-in coil:

### Function

1. Connect a 12 volt test lead to flat spade S/start terminal on solenoid and other lead to body or mounting surface of solenoid.
2. Manually push plunger IN and check if coil holds plunger retracted. Do not allow test leads to remain connected to solenoid for a prolonged period of time.

### Continuity

1. Use an ohmmeter set to audible or Rx2K scale, and connect 2 ohmmeter leads to 2 large post terminals.
2. Perform preceding solenoid hold-in coil function test and check for continuity. Meter should indicate continuity. Repeat test several times.

Condition	Conclusion
Solenoid fails to activate.	Replace solenoid.
No continuity is indicated.	
Plunger fails to stay retracted.	

# Disassembly/Inspection and Service



## ⚠ WARNING

Accidental Starts can cause severe injury or death.

Disconnect and ground spark plug lead(s) before servicing.

Before working on engine or equipment, disable engine as follows: 1) Disconnect spark plug lead(s). 2) Disconnect negative (-) battery cable from battery.

## External Engine Components

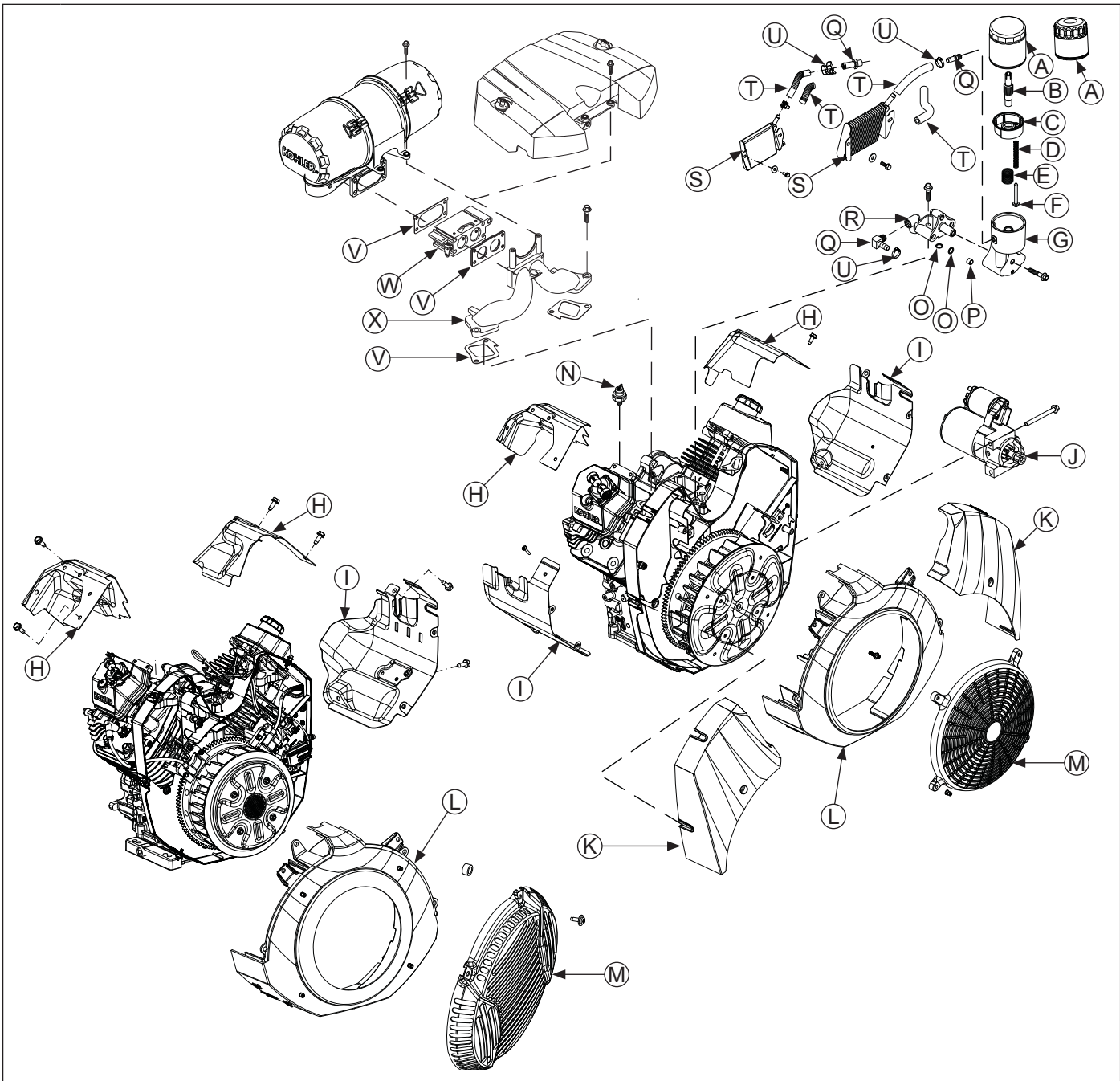

<b>A</b>	Oil Filter	<b>B</b>	Oil Filter Nipple	<b>C</b>	Oil Filter Cup	<b>D</b>	Valve Spring
<b>E</b>	Cup Spring	<b>F</b>	Valve	<b>G</b>	Oil Filter Housing	<b>H</b>	Valley Baffle
<b>I</b>	Outer Cylinder Baffle	<b>J</b>	Electric Starter	<b>K</b>	Cylinder Shroud	<b>L</b>	Blower Housing
<b>M</b>	Fixed Guard	<b>N</b>	Oil Sentry™	<b>O</b>	O-ring	<b>P</b>	Pin
<b>Q</b>	Fitting	<b>R</b>	Oil Filter Adapter	<b>S</b>	Oil Cooler	<b>T</b>	Hose
<b>U</b>	Hose Clamp	<b>V</b>	Gasket	<b>W</b>	Carburetor	<b>X</b>	Intake Manifold

Clean all parts thoroughly as engine is disassembled. Only clean parts can be accurately inspected and gauged for wear or damage. There are many commercially available cleaners that will quickly remove grease, oil and grime from engine parts. When such a cleaner is used, follow manufacturer's instructions and safety precautions carefully.

Make sure all traces of cleaner are removed before engine is reassembled and placed into operation. Even small amounts of these cleaners can quickly break down lubricating properties of engine oil.

## Disconnect Spark Plug Leads

NOTE: Pull on boot only, to prevent damage to spark plug lead.

1. Disconnect leads from spark plugs.
2. Shut off fuel supply.

## Drain Oil from Crankcase and Remove Oil Filter

1. Clean oil filter and housing area. Remove and discard oil filter.
2. Remove dipstick and 1 oil drain plug.
3. Allow ample time for oil to drain from crankcase.

## Remove Muffler

Remove exhaust system and attaching hardware from engine.

## Remove Cylinder Shrouds and Blower Housing

1. Remove top mounting screw and loosen shoulder screws on each side. Lift off cylinder shrouds.
2. Remove mounting screws and separate blower housing from lower half.

## Remove Electric Starter Motor

1. Disconnect leads from starter.
2. Remove screws and starter.

## Remove Air Cleaner Assembly

NOTE: Low-profile air cleaner is removed same way as heavy-duty air cleaner.

1. Disconnect breather hose from air cleaner and formed vent hose from vent port on carburetor.
2. Remove nuts, ground lead, and choke return spring bracket from mounting studs.
3. Remove screws securing air cleaner and main control bracket to intake manifold bosses.
4. Remove air cleaner as an assembly from engine.

## Removing Control Bracket, Governor Springs, and Lever

1. Unhook governed idle and governor springs from controls on main bracket and governor lever. Note color, location, and position of each.
2. Disconnect throttle linkage and dampening spring from governor lever at small bushing.
3. Carefully pry off pal nut, remove washers (note assembly order), and disconnect choke linkage from pivot lever. Do not lose any parts. Secure remaining pivot parts with tape to avoid losing them. Always use a new pal nut during reassembly.
4. Remove rear mounting screw on each side and lift off control bracket.
5. Loosen nut and remove governor lever from cross shaft.

## Remove Carburetor

	<b>WARNING</b> Explosive Fuel can cause fires and severe burns. Do not fill fuel tank while engine is hot or running.
Gasoline is extremely flammable and its vapors can explode if ignited. Store gasoline only in approved containers, in well ventilated, unoccupied buildings, away from sparks or flames. Spilled fuel could ignite if it comes in contact with hot parts or sparks from ignition. Never use gasoline as a cleaning agent.	

1. Disconnect fuel shut-off solenoid lead.
2. Remove fuel inlet hose from carburetor or fuel pump. Properly contain any remaining fuel.
3. Remove carburetor and linkages with choke return components as an assembly.
4. Remove carburetor gasket.
5. Carburetor and linkages can be separated as necessary.

## Remove Oil Sentry™ (if equipped)

1. Disconnect lead from Oil Sentry™ switch.
2. Remove Oil Sentry™ switch from closure plate.

## Remove Baffles and Intake Manifold

1. Remove screws securing valley baffles to cylinder heads and backing shroud assembly.
2. Remove screws securing outer cylinder baffles in place. Screws are accessed from backing shroud side.
3. Remove screws securing intake manifold to cylinder heads. Cut any wire ties that secure wiring harness or leads to intake manifold.
4. Remove intake manifold and gaskets.

## Disassembly/Inspection and Service

### Remove Oil Cooler

---

NOTE: New clamps are recommended any time disassembly is performed, or if clamps have been loosened (expanded) several times.

1. Remove oil cooler mounting screws. Do not lose any washers (if used).
2. Loosen clamps and disconnect hoses from oil cooler.

### Remove Oil Filter Housing and Oil Filter Adapter

---

NOTE: Further disassembly of oil filter housing assembly is not required unless being serviced individually. Follow substeps a, b, and c.

1. Remove screw securing oil filter housing and individual O-rings to adapter. Carefully separate parts.  
Perform following only if oil filter housing assembly requires individual servicing.
  - a. Remove nipple from cup and oil filter housing.
  - b. Remove oil filter cup and spring from housing.
  - c. Remove rubber valve and spring from cup.
2. Remove screw securing oil filter adapter and individual O-rings to crankcase, then carefully separate parts.

## Flywheel/Ignition Components

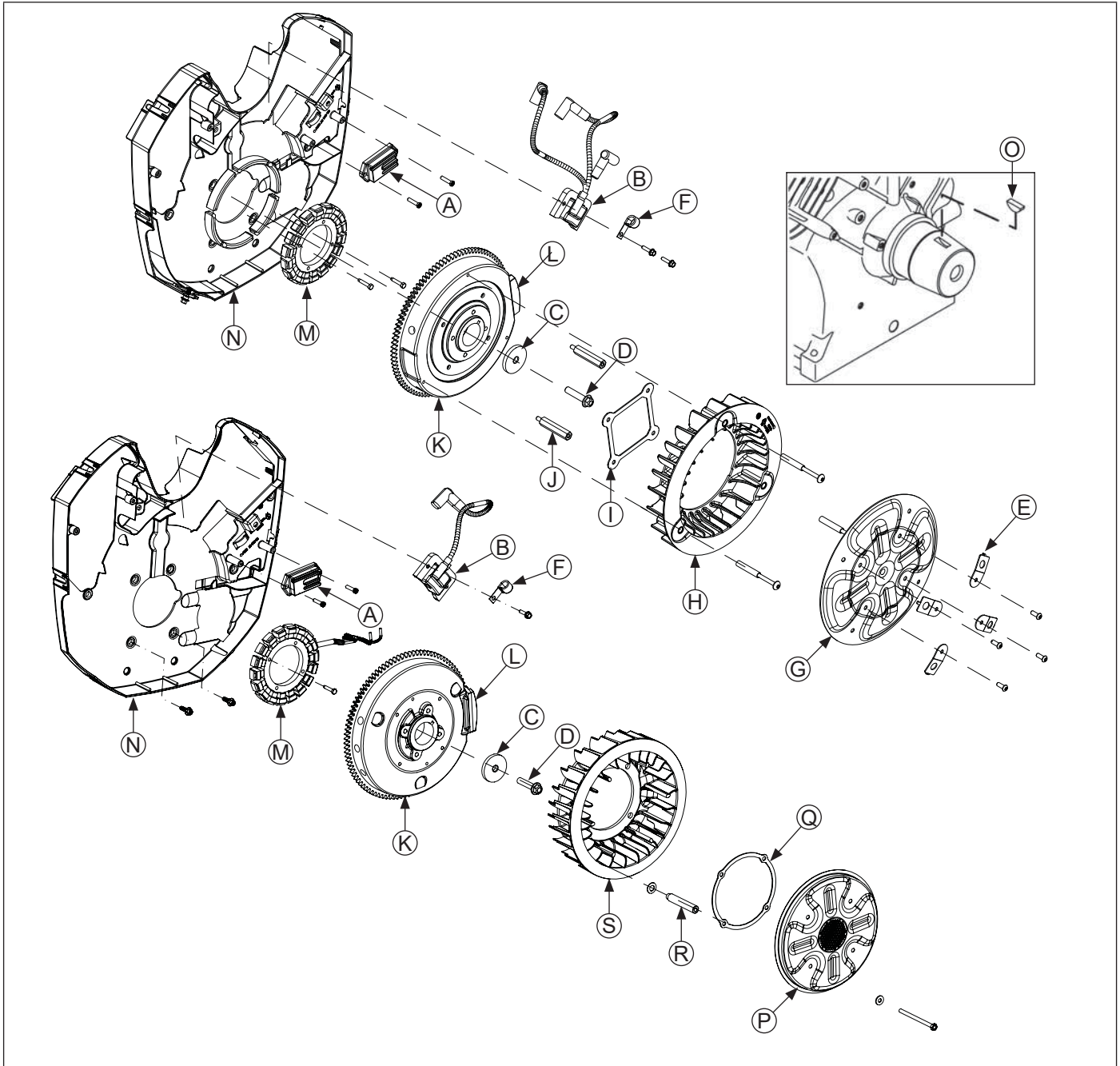

<b>A</b>	Rectifier-Regulator	<b>B</b>	Ignition Module	<b>C</b>	Washer	<b>D</b>	Flywheel Screw
<b>E</b>	Special Washer (Style A)	<b>F</b>	Wire Harness Clamp	<b>G</b>	Debris Screen (Style A)	<b>H</b>	Fan (Style A)
<b>I</b>	Stiffener (Style A)	<b>J</b>	Hex Stud	<b>K</b>	Flywheel	<b>L</b>	Magnet
<b>M</b>	Stator	<b>N</b>	Backing Shroud	<b>O</b>	Woodruff Key	<b>P</b>	Debris Screen (Style B)
<b>Q</b>	Support Ring (Style B)	<b>R</b>	Spacer (Style B)	<b>S</b>	Fan (Style B)		

# Disassembly/Inspection and Service

## Remove Ignition Modules

---

1. Rotate flywheel so magnet is away from modules.
2. Remove mounting screws and disconnect kill lead from ignition modules. Note position of ignition modules.

## Remove Debris Screen and Cooling Fan (Style A)

---

Remove screws, attaching hardware, hex studs securing debris screen, and stiffeners securing cooling fan to flywheel.

## Remove Debris Screen (Style B)

---

NOTE: Fan will be loose, but cannot be removed until after blower housing is removed.

1. Remove screws securing screen and remove screen.
2. Remove spacers, paying attention to curvature of spring washers between spacers and fan.

## Remove Flywheel

---

NOTE: Always use a flywheel strap wrench or holding tool to hold flywheel when loosening or tightening flywheel screw. Do not use any type of bar or wedge to hold flywheel. Use of such tools could cause flywheel to become cracked or damaged.

NOTE: Always use a flywheel puller to remove flywheel from crankshaft. Do not strike crankshaft or flywheel, as these parts could become cracked or damaged.

1. Use a flywheel strap wrench or holding tool to hold flywheel and loosen screw securing flywheel to crankshaft.
2. Remove screw and washer.
3. Use a puller to remove flywheel from crankshaft.
4. Remove woodruff key from crankshaft.

## Inspection

Inspect flywheel for cracks and flywheel keyway for damage. Replace flywheel if it is cracked. Replace flywheel, crankshaft, and key if flywheel key is sheared or keyway is damaged.

Inspect ring gear for cracks or damage. Rehlko does not provide ring gear as a serviceable part. Replace flywheel if ring gear is damaged.

## Remove Stator, Rectifier-Regulator, and Wiring Harness

---

1. Disconnect plug from rectifier-regulator. If B+ (center) lead must be removed from plug, use a small flat tool to bend locking tang. Then remove lead.
2. Remove mounting screws securing rectifier-regulator to backing shroud assembly. Note location of ground lead. If rectifier-regulator is not being replaced, it may remain mounted to lower blower housing.
3. Remove screws securing stator to crankcase and carefully separate stator wires from molded clips.
4. Unhook wiring harness from molded clips if it is being serviced separately.

## Remove Backing Shroud Assembly

---

Remove mounting screws securing backing shroud assembly to crankcase.

## Remove Spark Plugs

---

Remove spark plug from each cylinder head.

## Cylinder Head Components

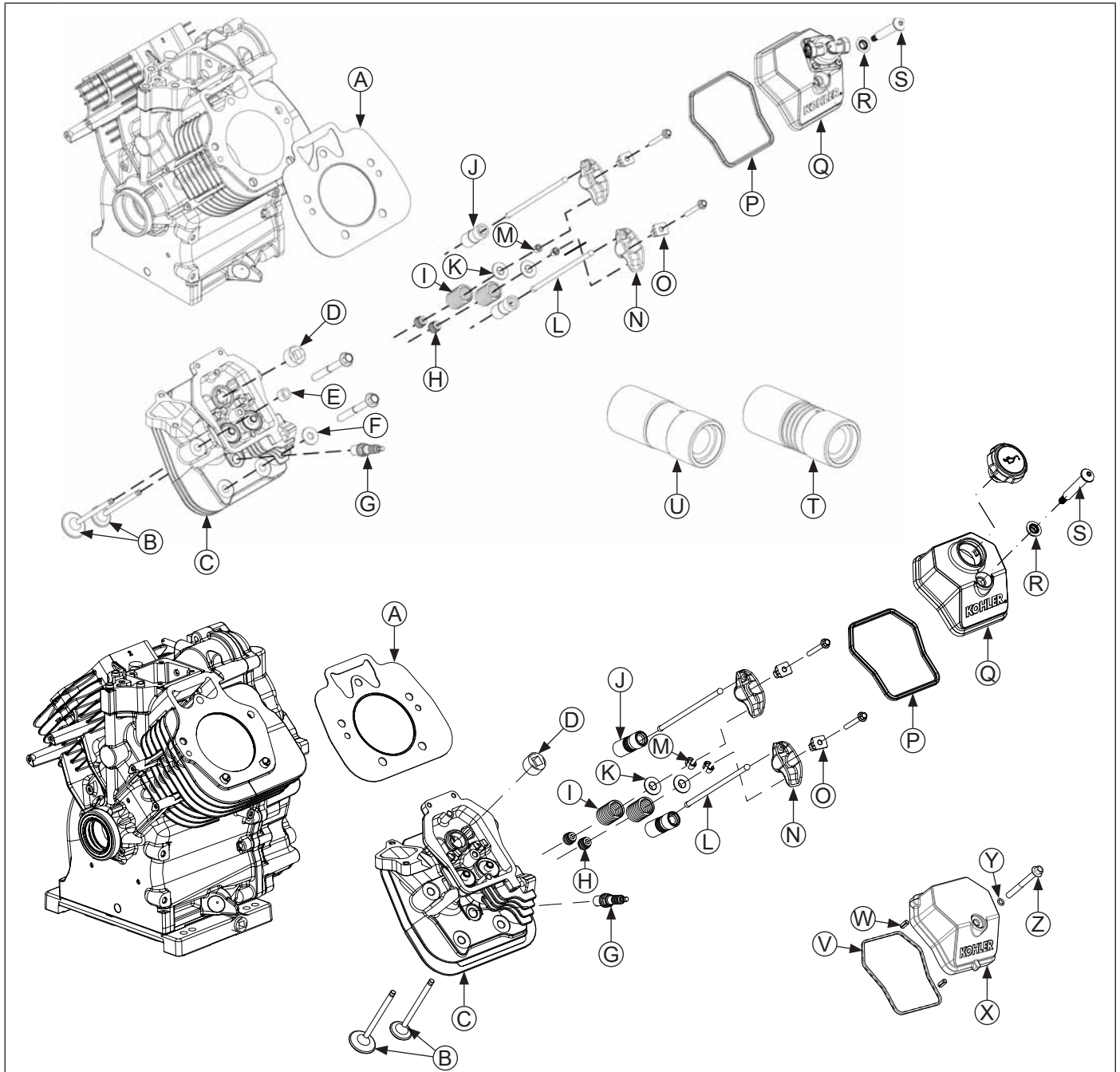

<b>A</b>	Gasket	<b>B</b>	Valve	<b>C</b>	Cylinder Head	<b>D</b>	Pipe Plug
<b>E</b>	Spacer	<b>F</b>	Washer	<b>G</b>	Spark Plug	<b>H</b>	Valve Stem Seal
<b>I</b>	Valve Spring	<b>J</b>	Hydraulic Lifter	<b>K</b>	Valve Spring Retainer	<b>L</b>	Push Rod
<b>M</b>	Valve Spring Keeper	<b>N</b>	Rocker Arm	<b>O</b>	Rocker Arm Pivots	<b>P</b>	Valve Cover Seal (Plastic Valve Cover)
<b>Q</b>	Valve Cover (Plastic)	<b>R</b>	Grommet (Plastic Valve Cover)	<b>S</b>	Screw (Plastic Valve Cover)	<b>T</b>	Hydraulic Lifter Style A (Ribbed)
<b>U</b>	Hydraulic Lifter Style B (Smooth)	<b>V</b>	Valve Cover Seal (Aluminum Valve Cover)	<b>W</b>	Roll Pin (Aluminum Valve Cover)	<b>X</b>	Valve Cover (Aluminum)
<b>Y</b>	O-Ring (Aluminum Valve Cover)	<b>Z</b>	Screw (Aluminum Valve Cover)				

# Disassembly/Inspection and Service

## Remove Valve Covers and Fuel Pump

	<b>⚠ WARNING</b>
	Explosive Fuel can cause fires and severe burns. Do not fill fuel tank while engine is hot or running.
Gasoline is extremely flammable and its vapors can explode if ignited. Store gasoline only in approved containers, in well ventilated, unoccupied buildings, away from sparks or flames. Spilled fuel could ignite if it comes in contact with hot parts or sparks from ignition. Never use gasoline as a cleaning agent.	

NOTE: Remove valve covers based on style of fuel pump used.

### Mechanical Fuel Pump

Mechanical fuel pump is part of valve cover and not serviced separately. Remove with valve cover. Disconnect fuel lines at fuel pump fittings. Properly contain any remaining fuel.

### Electric Fuel Pump

Removal will be determined based on mounted location and application. Disconnect lead connections, fuel line connections, and mounting hardware as required. Properly contain any remaining fuel.

### Valve Covers

#### Plastic Valve Covers

1. Remove screw and grommet securing each valve cover.
2. Remove valve cover and seal from each cylinder head. Note locations of individual valve covers if they are different.

#### Aluminum Valve Covers

NOTE: A new valve cover seal must be installed whenever an aluminum valve cover is removed from cylinder head.

1. Remove screw and O-ring securing each valve cover.
2. Remove valve cover and seal from each cylinder head. Note locations of individual valve covers if they are different. Remove seal from valve cover; discard seal.

## Remove Cylinder Heads and Hydraulic Lifters

NOTE: Exhaust lifters are located on output shaft side of engine while intake lifters are located on fan side of engine. Cylinder head number is embossed on outside of each cylinder head.

1. Remove pipe plug from cylinder head to access screw in upper center location.
2. Remove screws securing each cylinder head. Note locations of washers and spacer.
3. Mark position of push rods as either intake or exhaust and cylinder 1 or 2. Push rods should always be reinstalled in same positions.
4. Carefully remove push rods, cylinder head and head gasket.

5. Repeat procedure for other cylinder head.
6. Remove lifters from lifter bores. Use a hydraulic lifter tool. Do not use a magnet to remove lifters. Mark lifters by location, as either intake or exhaust and cylinder 1 or 2. Hydraulic lifters should always be reinstalled in same position.

### Inspection

Check base surface of hydraulic lifters for wear or damage. If lifters need to be replaced, apply a liberal coating of Rehlko lubricant to base of each new lifter before it is installed.

### Bleeding Lifters Style A (Ribbed)

To prevent a possible bent push rod or broken rocker arm, it is important to bleed any excess oil out of lifters before they are installed.

1. Cut a 50-75 mm (2-3 in.) piece from end of an old push rod and chuck it in a drill press.
2. Lay a rag or shop towel on table of drill press and place lifter, open end up, on towel.
3. Lower chucked push rod until it contacts plunger in lifter. Slowly pump plunger 2 or 3 times to force oil out of feed hole in side of lifter.

### Bleeding Lifters Style B (Smooth)

To prevent a possible bent push rod or broken rocker arm, it is important to bleed any excess oil out of lifters before they are installed.

1. Lay a rag or shop towel on table of drill press. Place an 8 mm (5/16 in.) socket on towel with well end up, then place open end of lifter on socket. Ensure socket does not contact lifter ball surface.
2. Place some material, such as wood, plastic, or aluminum on top of lifter to protect lifter finish.
3. Lower drill press chuck until it contacts material on lifter. Slowly pump lifter 2 or 3 times to force oil out of feed hole in side of lifter.

## Disassemble Cylinder Heads

NOTE: These engines use valve stem seals on intake and exhaust valves. Use a new seal whenever valves are removed, or if seal is deteriorated in any way. Never reuse an old seal.

1. Remove screws, rocker arm pivots, and rocker arms from cylinder head.
2. Compress valve springs using a valve spring compressor.
3. Once valve spring is compressed, remove following items:
  - Valve spring keepers.
  - Valve spring retainers.
  - Valve springs.
  - Valve spring caps.
  - Intake and exhaust valves (mark position).
  - Valve stem seals.
4. Repeat above procedure for other cylinder head. Do not interchange parts from one cylinder head to another.

## Inspection and Service Valve Details

Dimension		Intake	Exhaust
<b>A</b>	Seat Angle	89°	89°
<b>B</b>	Seat Taper	30°	30°
<b>C</b>	Guide Depth	8.5 mm (0.334 in.)	8.5 mm (0.334 in.)
<b>D</b>	Guide I.D.	7.038/7.058 mm (0.2771/0.2779 in.)	7.038/7.058 mm (0.2771/0.2779 in.)
<b>E</b>	Valve Head Diameter	38.625/38.685 mm (1.5206/1.5230 in.)	31.625/31.825 mm (1.2450/1.2549 in.)
<b>F</b>	Valve Face Angle	45°	45°
<b>G</b>	Valve Margin (Min.)	1.0 mm (0.0393 in.)	1.0 mm (0.0393 in.)
<b>H</b>	Valve Stem Diameter	6.982/7.000 mm (0.2749/0.2756 in.)	6.970/6.988 mm (0.2744/0.2751 in.)

After cleaning, check flatness of cylinder head and corresponding top surface of crankcase using a surface plate or precision straight edge and feeler gauge. Maximum allowable out of flatness is 0.076 mm (0.003 in.).

Carefully inspect valve mechanism parts. Inspect valve springs and related hardware for excessive wear or distortion. Check valves and valve seat area or inserts for evidence of deep pitting, cracks, or distortion. Check clearance of valve stems in guides.

Hard starting or loss of power accompanied by high fuel consumption may be symptoms of faulty valves. Although these symptoms could also be attributed to worn rings, remove and check valves first. After removal, clean valve heads, faces, and stems with a power wire brush.

Then, carefully inspect each valve for defects such as a warped head, excessive corrosion, or a worn stem end. Replace valves found to be in bad condition.

### Valve Guides

If a valve guide is worn beyond specifications, it will not guide valve in a straight line. This may result in burnt valve faces or seats, loss of compression, and excessive oil consumption.

To check valve guide-to-valve stem clearance, thoroughly clean valve guide and, using a split-ball gauge, measure inside diameter of guide. Then, using an outside micrometer, measure diameter of valve stem at several points on stem where it moves in valve guide.

Use largest stem diameter to calculate clearance by subtracting stem diameter from guide diameter. If intake clearance exceeds 0.038/0.076 mm (0.0015/0.0030 in.) or exhaust clearance exceeds 0.050/0.088 mm (0.0020/0.0035 in.), determine if valve stem or guide is responsible for excessive clearance.

Maximum (I.D.) wear on intake valve guide is 7.135 mm (0.2809 in.) and 7.159 mm (0.2819 in.) for exhaust guide. Guides are not removable but can be reamed 0.25 mm (0.010 in.) oversize. Valves with 0.25 mm oversize stems must then be used.

If guides are within limits but valve stems are worn beyond limits, install new valves.

### Valve Seat Inserts

Hardened steel alloy intake and exhaust valve seat inserts are press fitted into cylinder head. Inserts are not replaceable but can be reconditioned if not too badly pitted or distorted. If cracked or badly warped, cylinder head should be replaced.

Recondition valve seat inserts following instructions provided with valve seat cutter being used. Final cut should be made with an 89° cutter as specified for valve seat angle. Cutting proper 45° valve face angle as specified, and proper valve seat angle (44.5°, half of full 89° angle), will achieve desired 0.5° (1.0° full cut) interference angle where maximum pressure occurs on outside diameters of valve face and seat.

# Disassembly/Inspection and Service

## Lapping Valves

Reground or new valves must be lapped in, to provide proper fit. Use a hand valve grinder with a suction cup for final lapping. Lightly coat valve face with a fine grade of grinding compound, then rotate valve on its seat with grinder. Continue grinding until a smooth surface is obtained on seat and on valve face. Thoroughly clean cylinder head in soap and hot water to remove all traces of grinding compound. After drying cylinder head, apply a light coating of SAE 10 oil to prevent rusting.

## Valve Stem Seals

These engines use valve stem seals on intake and exhaust valves. Always use new seals when valves are removed from cylinder head. Seals should also be replaced if deteriorated or damaged in any way. Never reuse an old seal.

## Breather/Closure Plate/Oil Reservoir Components

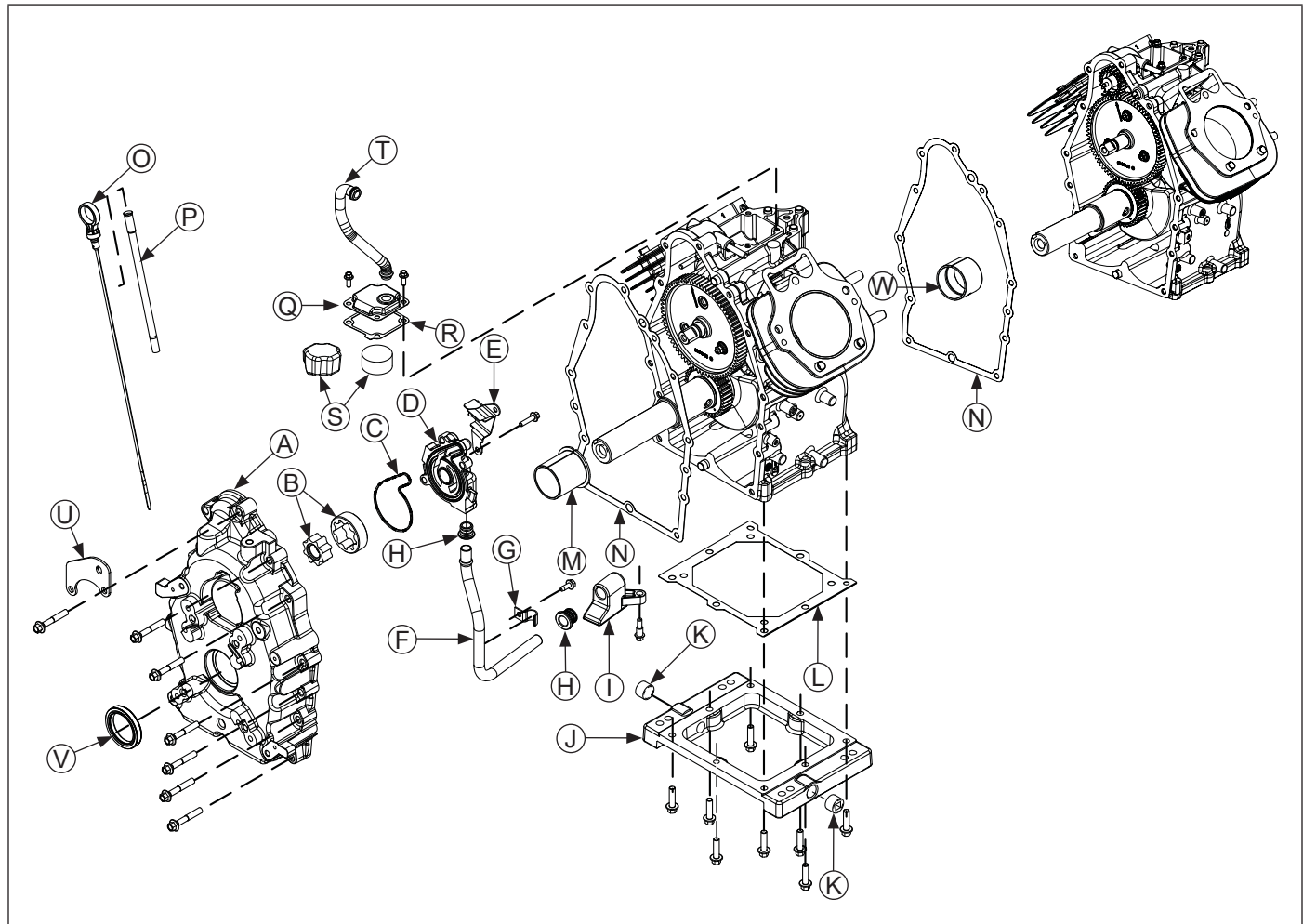

<b>A</b>	Closure Plate	<b>B</b>	Gerotor Gears	<b>C</b>	Oil Pump O-ring	<b>D</b>	Oil Pump Housing
<b>E</b>	Relief Valve Baffle	<b>F</b>	Pickup Tube	<b>G</b>	Clamp	<b>H</b>	Inlet Seal
<b>I</b>	Pickup Screen	<b>J</b>	Oil Reservoir	<b>K</b>	Drain Plug	<b>L</b>	Gasket
<b>M</b>	Crankshaft Thrust Bearing (Flange PTO)	<b>N</b>	Closure Plate Gasket	<b>O</b>	Dipstick	<b>P</b>	Dipstick Tube
<b>Q</b>	Breather Assembly	<b>R</b>	Breather Gasket	<b>S</b>	Filter	<b>T</b>	Breather Hose
<b>U</b>	Lifting Strap	<b>V</b>	Oil Seal	<b>W</b>	Crankshaft Non-Thrust Bearing (PTO)		

## Remove Breather Assembly

1. Remove fasteners securing breather assembly, breather adapter (style based on spec), and gaskets to crankcase.
2. Carefully break gasket seals and remove all parts. Do not pry on sealing surfaces as it could cause damage resulting in leaks. Note assembly and orientation of parts.

## Remove Oil Reservoir and Pickup Screen

1. Remove screws securing oil reservoir and gasket to engine.
2. Remove mounting screw and carefully work pickup screen off end of pickup tube.

## Remove Closure Plate Assembly

1. Remove screws securing closure plate to crankcase.
2. Locate protruding tabs on closure plate. Carefully tap to break gasket seal. Do not pry on sealing surfaces as this could cause leaks. Separate closure plate from crankcase. Remove old gasket.

### Inspection

Inspect oil seal in closure plate and remove it if worn or damaged.

Inspect crankshaft bearing surface for wear or damage. Replace bearing or closure plate assembly if required.

## Oil Pump Assembly

### Disassembly

1. Remove screws securing oil pump housing including relief valve baffle and clamp for pickup tube.
2. Remove oil pump housing and pickup tube from closure plate.
3. Remove oil pump gerotor gears from closure plate recess.
4. Remove oil pickup by pulling it free from oil pump body.
5. Relief valve is a one-piece style, staked to oil pump housing; removal should not be attempted, nor is internal servicing possible. If a problem with relief valve is encountered, oil pump should be replaced.

### Inspection

Inspect oil pump housing, gerotor gears, and closure plate recess for nicks, burrs, wear, or any visible damage. Inspect inlet seal for pickup tube in housing. If any parts are worn or damaged, replace seal, oil pump or closure plate as required.

## Reassembly Torque Sequence

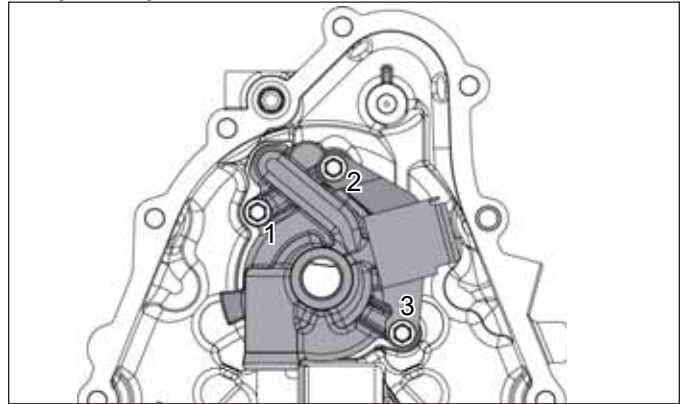

1. Make sure recess in closure plate for oil pump gerotor gears is clean.
2. Lubricate oil pump gerotor gears with grease (Lubriplate® 100 or equivalent), and install into recess.
3. Lightly lubricate with oil and install inlet seal into oil pump housing until it is fully seated.
4. Install O-ring in groove of oil pump housing. Use a small quantity of grease to hold it in place.
5. Lightly lubricate I.D. of inlet seal with oil and carefully insert ferruled end of pickup tube through grommet, into oil pump housing. Position pickup tube so outboard end faces up.
6. Install oil pump housing with pickup tube, over oil pump boss and gears. Position relief valve baffle on screw locations 2 and 3. Align all 3 screw locations.
7. Install clamp for pickup tube and finger tighten screw. Check alignment of parts and torque oil pump housing screws to 9.9 N·m (88 in. lb.) using sequence below:
  - a. Install fastener into location 1 and lightly tighten to position pump.
  - b. Install fastener into location 2 and fully torque to recommended value.
  - c. Install fastener into location 3 and fully torque to recommended value.
  - d. Finish torquing fastener in location 1 to recommended value.
8. Torque clamp (pickup tube) mounting screw to 11.3 N·m (100 in. lb.) into new hole or 7.7 N·m (68 in. lb.) into used hole.

# Disassembly/Inspection and Service

## Crankcase Components

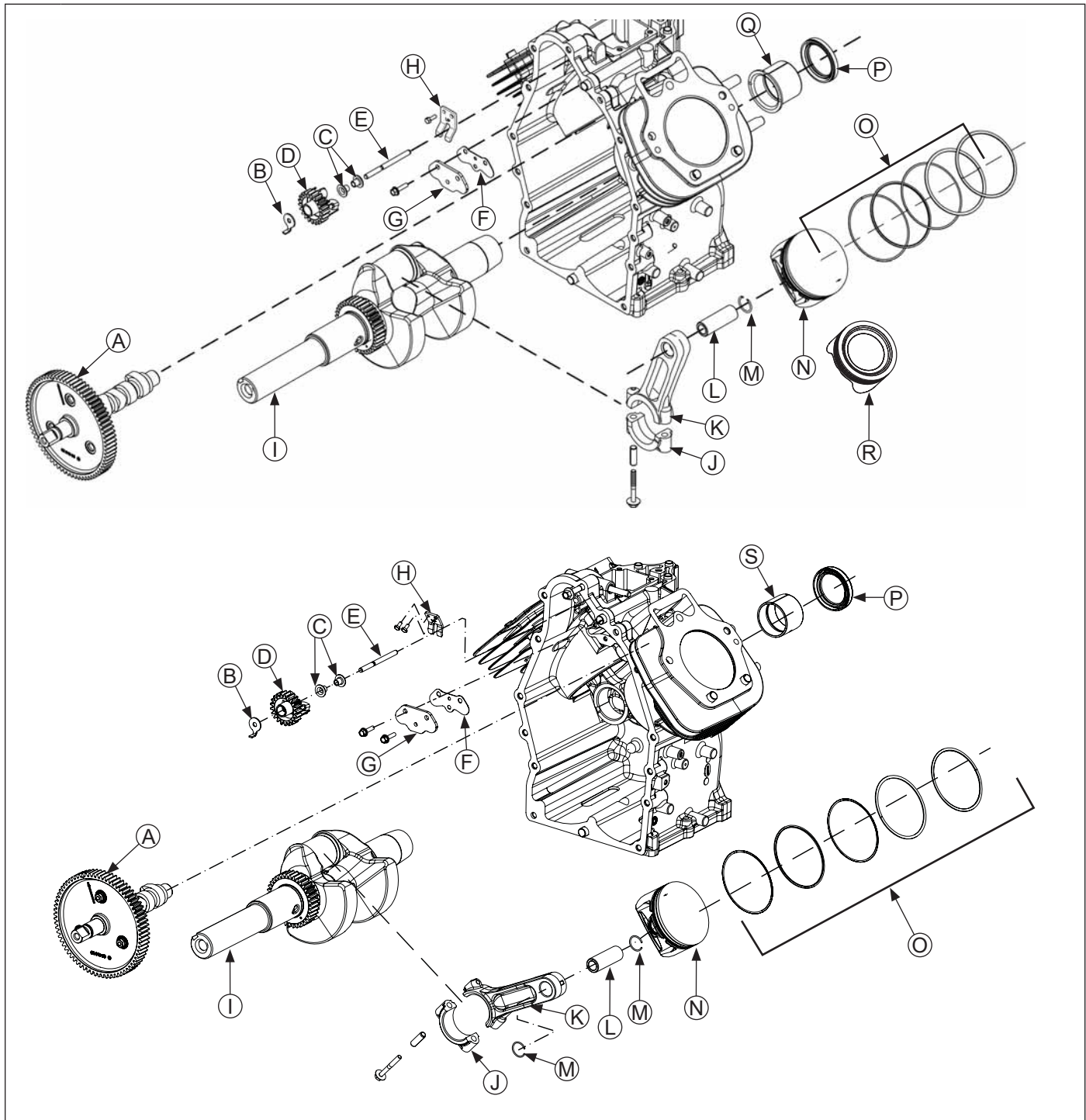

<b>A</b>	Camshaft	<b>B</b>	Locking Tab	<b>C</b>	Regulating Pin	<b>D</b>	Governor Gear
<b>E</b>	Cross Shaft	<b>F</b>	Lifter Feed Cover Gasket	<b>G</b>	Lifter Feed Cover	<b>H</b>	Governor Yoke
<b>I</b>	Crankshaft	<b>J</b>	Connecting Rod End Cap	<b>K</b>	Connecting Rod	<b>L</b>	Piston Pin
<b>M</b>	Piston Pin Retainer	<b>N</b>	Piston (Style A)	<b>O</b>	Piston Ring Set	<b>P</b>	Oil Seal
<b>Q</b>	Crankshaft Thrust Bearing (Flange Flywheel)	<b>R</b>	Piston (Style B)	<b>S</b>	Crankshaft Non-Thrust Bearing (Flywheel)		

## Remove Camshaft

Remove camshaft and shim (if used).

### Inspection

Check lobes of camshaft for wear or damage. Inspect cam gear for badly worn, chipped, or missing teeth. Replacement of camshaft will be necessary if any of these conditions exist.

## Remove Connecting Rods with Pistons and Rings

NOTE: If a carbon ridge is present at top of either cylinder bore, use a ridge reamer tool to remove ridge before attempting to remove piston.

NOTE: Cylinders are numbered on crankcase. Use numbers to mark each end cap, connecting rod and piston for reassembly. Do not mix end caps and connecting rods.

1. Remove screws securing closest connecting rod end cap. Remove end cap.
2. Carefully remove connecting rod and piston assembly from cylinder bore.
3. Repeat above procedures for other connecting rod and piston assembly.

### Connecting Rods

Offset, stepped-cap connecting rods are used in these engines.

### Inspection and Service

Check bearing area (big end) for excessive wear, score marks, running and side clearances. Replace rod and cap if scored or excessively worn.

Service replacement connecting rods are available in STD crankpin size and 0.25 mm (0.010 in.) undersize. Always refer to appropriate parts information to ensure that correct replacements are used.

## Piston and Rings

### Inspection

#### Piston and Rings Components and Details

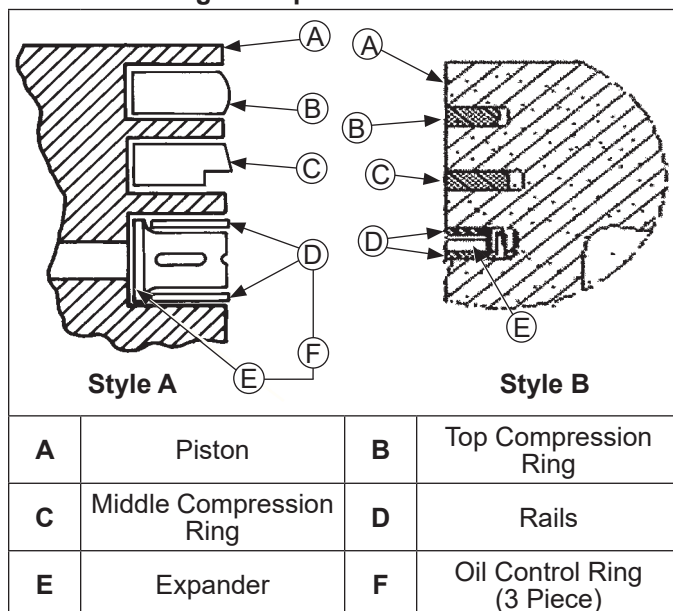

Scuffing and scoring of pistons and cylinder walls occurs when internal engine temperatures approach welding point of piston. Temperatures high enough to do this are created by friction, which is usually attributed to improper lubrication and/or overheating of engine.

Normally, very little wear takes place in piston boss-piston pin area. If original piston and connecting rod can be reused after new rings are installed, original pin can also be reused but new piston pin retainers are required. Piston pin is included as part of piston assembly – if pin boss in piston or pin are worn or damaged, a new piston assembly is required.

Ring failure is usually indicated by excessive oil consumption and blue exhaust smoke. When rings fail, oil is allowed to enter combustion chamber where it is burned along with fuel. High oil consumption can also occur when piston ring end gap is incorrect because ring cannot properly conform to cylinder wall under this condition. Oil control is also lost when ring gaps are not staggered during installation.

When cylinder temperatures get too high, lacquer and varnish collect on pistons causing rings to stick, which results in rapid wear. A worn ring usually takes on a shiny or bright appearance.

Scratches on rings and pistons are caused by abrasive material such as carbon, dirt, or pieces of hard metal.

Detonation damage occurs when a portion of fuel charge ignites spontaneously from heat and pressure shortly after ignition. This creates 2 flame fronts which meet and explode to create extreme hammering pressures on a specific area of piston. Detonation generally occurs from using low octane fuels.

Preignition or ignition of fuel charge before timed spark can cause damage similar to detonation. Preignition damage is often more severe than detonation damage. Preignition is caused by a hot spot in combustion chamber from sources such as glowing carbon deposits, blocked cooling fins, an improperly seated valve, or wrong spark plug(s).

Replacement pistons are available in STD bore size, and in 0.25 mm (0.010 in.), and 0.50 mm (0.020 in.) oversize. Replacement pistons include new piston ring sets and new piston pins.

Replacement ring sets are also available separately for STD, 0.25 mm (0.010 in.), and 0.50 mm (0.020 in.) oversize pistons. Always use new piston rings when installing pistons. Never reuse old rings.

Some important points to remember when servicing piston rings:

# Disassembly/Inspection and Service

## Piston Style A

1. Cylinder bore must be de-glazed before service ring sets are used.
2. If cylinder bore does not need re-boring and if old piston is within wear limits and free of score or scuff marks, old piston may be reused.
3. Remove old rings and clean up grooves. Never reuse old rings.
4. Before installing new rings on piston, place top 2 rings, each in turn, in its running area in cylinder bore and check end gap. Top and middle compression ring end gap clearance is 0.25/0.56 mm (0.0100/0.0224 in.) for a new bore, or 0.94 mm (0.037 in.) for a used bore.
5. After installing new compression (top and middle) rings on piston, make sure top compression ring-to-groove side clearance is 0.025/0.048 mm (0.0010/0.0019 in.) and middle compression ring-to-groove side clearance 0.015/0.037 mm (0.0006/0.0015 in.). If side clearance is greater than specified, a new piston must be used.

## Piston Style B

1. Cylinder bore must be de-glazed before service ring sets are used.
2. If cylinder bore does not need re-boring and if old piston is within wear limits and free of score or scuff marks, old piston may be reused.
3. Remove old rings and clean up grooves. Never reuse old rings.
4. Before installing new rings on piston, place top 2 rings, each in turn, in its running area in cylinder bore and check end gap. Top compression ring end gap clearance is 0.125/0.304 mm (0.0049/0.0120 in.) for a new bore, or 0.515 mm (0.0203 in.) for a used bore. Middle compression ring end cap is 0.900/1.179 mm (0.0354/0.0464 in.) for a new bore, or 1.432 mm (0.0564 in.) for a used bore.
5. After installing new compression (top and middle) rings on piston, make sure top compression ring-to-groove side clearance and is 0.030/0.070 mm (0.0010/0.0026 in.) and middle compression ring-to-groove side clearance 0.030/0.070 mm (0.0010/0.0026 in.). If side clearance is greater than specified, a new piston must be used.

## Install New Piston Rings

### Piston Ring Orientation

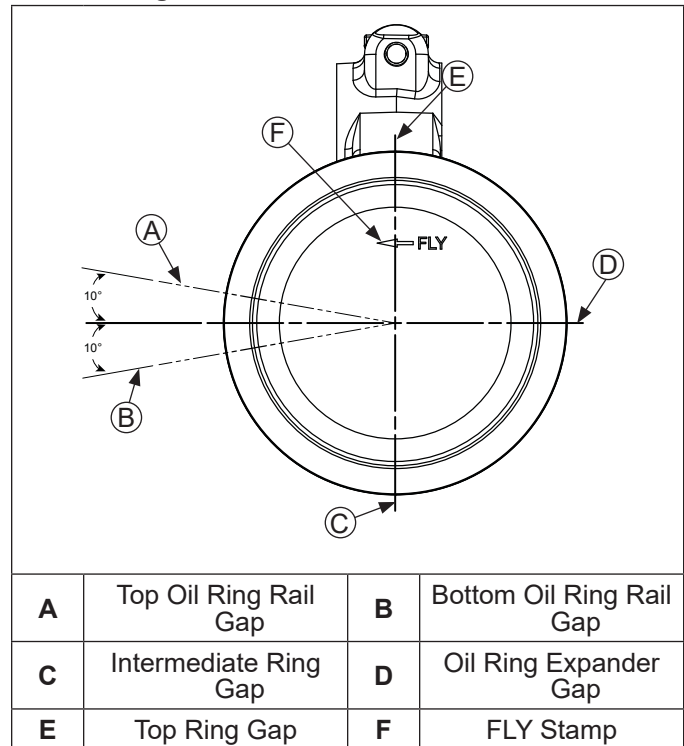

**NOTE:** Rings must be installed correctly. Ring installation instructions are usually included with new ring sets. Follow instructions carefully. Use a piston ring expander to install rings. Install bottom (oil control) ring first and top compression ring last.

To install new piston rings, proceed as follows:

1. Oil control ring (bottom groove): Install expander and then rails. Make sure ends of expander are not overlapped.
2. Middle compression ring (center groove): Install center ring using a piston ring installation tool. Make sure identification mark is up or colored dye stripe (if contained), is to left of end gap.
3. Top compression ring (top groove): Install top ring using a piston ring expander. Make sure identification mark is up or colored dye stripe (if contained), is to left of end gap.

## Remove Crankshaft

**NOTE:** If crankpin is reground, visually check to ensure that fillet blends smoothly with crankpin surface.

Carefully pull crankshaft from crankcase. Note thrust washers and shims if used.

## Inspection and Service

### Crankshaft Components and Details

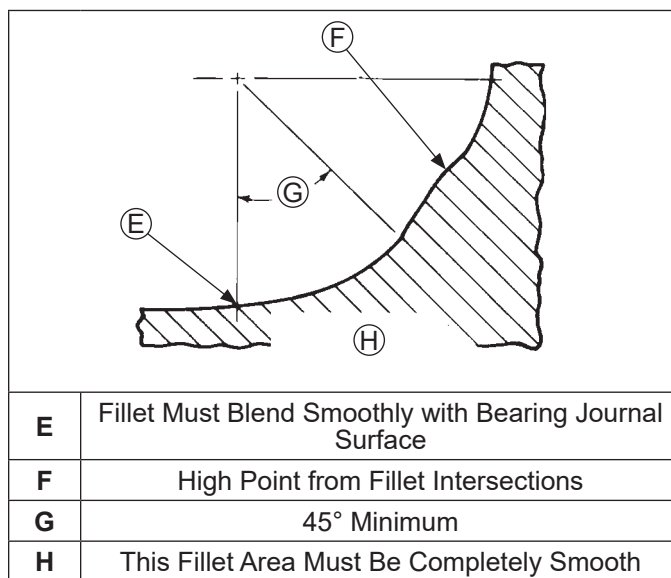
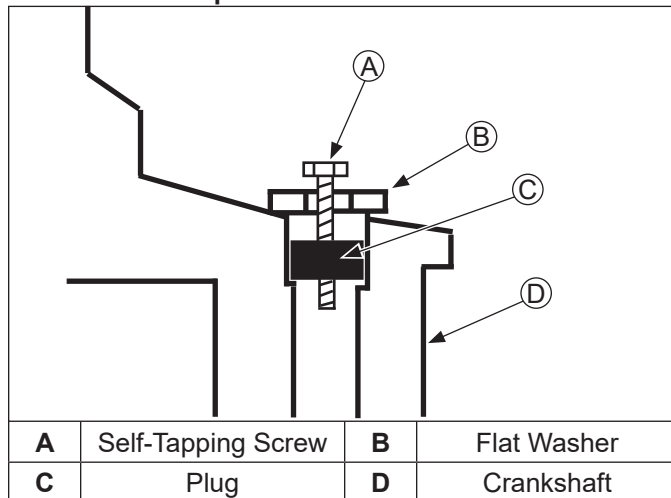

Inspect gear teeth of crankshaft. If teeth are badly worn, chipped, or some are missing, replacement of crankshaft will be necessary.

Inspect crankshaft bearing surfaces for scoring, grooving, etc. Replaceable bearing is used in crankshaft bore of closure plate and/or crankcase. Do not replace bearing unless they show signs of damage or are out of running clearance 0.040/0.167 mm (0.0015/0.0065 in.). If crankshaft turns easily, without noise, and there is no evidence of scoring, grooving, etc., on races or bearing surfaces, bearing can be reused.

Inspect crankshaft keyways. If they are worn or chipped, replacement of crankshaft will be necessary.

Inspect crankpin for score marks or metallic pickup. Slight score marks can be cleaned with crocus cloth soaked in oil. If wear limits, as stated in Clearance Specifications, are exceeded, it will be necessary to replace crankshaft or regrind crankpin to 0.25 mm (0.010 in.) undersize. If reground, a 0.25 mm (0.010 in.) undersize connecting rod (big end) must then be used to achieve proper running clearance. Measure crankpin for size, taper, and out-of-round.

### Clearance Specifications-Connecting Rod Journal

O.D. - New	43.982/44.000 mm (1.731/1.732 in.)
O.D. - Max. Wear Limit	43.97 mm (1.731 in.)
Max. Taper	0.018 mm (0.0007 in.)
Max. Out-of-Round	0.025 mm (0.0010 in.)
Width	53.00/53.09 mm (2.0866/2.0901 in.)

Connecting rod journal can be ground 1 size under. When grinding a crankshaft, grinding stone deposits can get caught in oil passages, which could cause severe engine damage. Removing crankpin plug when crankshaft is ground provides easy access for removing any grinding deposits that may collect in oil passages.

Use following procedure to remove and replace plug.

### Remove Crankshaft Plug

1. Drill a 3/16 in. hole through plug in crankshaft.
2. Thread a 3/4 in. or 1 in. long self-tapping screw with a flat washer into drilled hole. Flat washer must be large enough to seat against shoulder of plug bore.
3. Tighten self-tapping screw until it draws plug out of crankshaft.

### Install New Crankshaft Plug

Use 1 single cylinder camshaft pin, as a driver and tap plug into plug bore until it seats at bottom of bore. Make sure plug is tapped in evenly to prevent leakage.

### Remove Governor Gear Assembly

Governor gear is held onto shaft by small molded tabs in gear. When gear is removed from shaft, these tabs are destroyed and gear must be replaced. Therefore, remove gear only if absolutely necessary. If governor cross shaft, yoke, or gear condition does not require removal, governor gear may be left in place. If removal is necessary, perform as follows:

1. Remove locking tab thrust washer and note orientation.
2. Using a screwdriver, carefully pry upward to unseat governor gear assembly from governor gear shaft. Remove regulating pin and governor gear assembly.
3. Inspect governor gear shaft for wear or damage. Remove shaft only if replacement is needed.

### Inspection

Governor gear is located within crankcase. Inspect governor gear teeth. Replace gear if it is worn, chipped, or if any teeth are missing. Inspect governor weights. They should move freely in governor gear.

# Disassembly/Inspection and Service

## Remove Governor Yoke, Cross Shaft, and Seal

1. Remove mounting screws securing yoke to governor cross shaft.
2. Pull governor cross shaft out of crankcase and remove seal.

## Remove Lifter Feed Chamber Cover and Gaskets

Remove screws securing lifter feed chamber baffle (some models only), cover, and gaskets. Carefully separate parts from crankcase.

## Remove Flywheel and PTO End Oil Seals

Remove oil seals from crankcase and closure plate using a seal puller.

## Remove Crankshaft Bearing (flywheel/PTO)

NOTE: Bearing should only be removed if replacement is required due to wear. If removal is performed, use a press and support casting surface around bearing flange. Do not press against or support by gasket/outer perimeter surface.

## Crankcase

### Inspection and Service

Check all gasket surfaces to make sure they are free of gasket fragments. Gasket surfaces must also be free of deep scratches or nicks.

Inspect crankshaft bearing (if equipped) for wear or damage. Replace bearing or crankcase using a miniblock or short block as required.

Check cylinder bore for scoring. In severe cases, unburned fuel can cause scuffing and scoring of cylinder wall. It washes necessary lubricating oils off piston and cylinder wall. As raw fuel seeps down cylinder wall, piston rings make metal to metal contact with wall. Scoring of cylinder wall can also be caused by localized hot spots resulting from blocked cooling fins or from inadequate or contaminated lubrication.

If cylinder bore is badly scored, excessively worn, tapered, or out-of-round, resizing is necessary. Use an inside micrometer to determine amount of wear, then select nearest suitable oversize of either 0.25 mm (0.010 in.) or 0.50 mm (0.020 in.). Resizing to these oversizes will allow usage of available oversize piston and ring assemblies. Initially, resize using a boring bar, then use following procedures for honing cylinder.

## Honing Detail

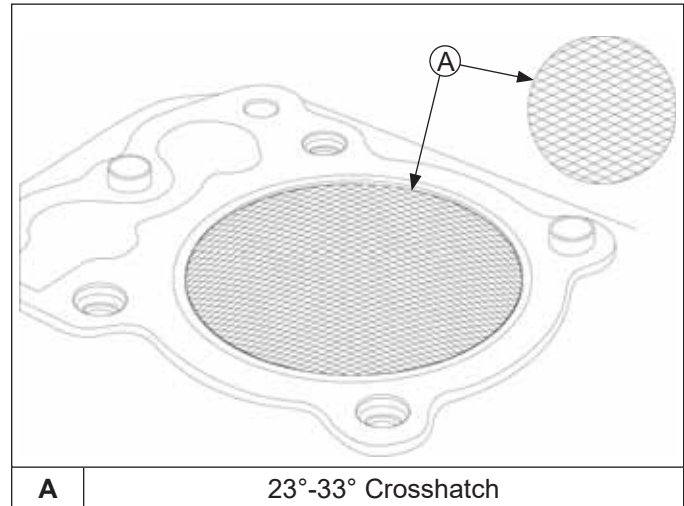

NOTE: Rehlko pistons are custom-machined to exacting tolerances. When oversizing a cylinder, it should be machined exactly 0.25 mm (0.010 in.) or 0.50 mm (0.020 in.) over new diameter. Corresponding oversize Rehlko replacement piston will then fit correctly.

While most commercially available cylinder hones can be used with either portable drills or drill presses, use of a low speed drill press is preferred as it facilitates more accurate alignment of bore in relation to crankshaft crossbore. Honing is best accomplished at a drill speed of about 250 RPM and 60 strokes per minute. After installing coarse stones in hone, proceed as follows:

1. Lower hone into bore and after centering, adjust so stones are in contact with cylinder wall. Use of a commercial cutting-cooling agent is recommended.
2. With lower edge of each stone positioned even with lowest edge of bore, start drill and honing process. Move hone up and down while resizing to prevent formation of cutting ridges. Check size frequently.
3. When bore is within 0.064 mm (0.0025 in.) of desired size, remove coarse stones and replace them with burnishing stones. Continue with burnishing stones until bore is within 0.013 mm (0.0005 in.) of desired size and then use finish stones (220-280 grit) and polish bore to its final size. A crosshatch should be observed if honing is done correctly. Crosshatch should intersect at approximately 23°-33° off horizontal. Too flat an angle could cause rings to skip and wear excessively, and too steep an angle will result in high oil consumption.
4. After resizing, check bore for roundness, taper, and size. Use an inside micrometer, telescoping gauge, or bore gauge to take measurements. These measurements should be taken at 3 locations in cylinder – at top, middle, and bottom. There are 2 measurements that should be taken (perpendicular to each other) at all 3 locations.

## Clean Cylinder Bore After Honing

Proper cleaning of cylinder walls following boring and/or honing is very critical to a successful overhaul. Machining grit left in cylinder bore can destroy an engine in less than 1 hour of operation after a rebuild.

Final cleaning operation should always be a thorough scrubbing with a brush and hot, soapy water. Use a strong detergent that is capable of breaking down machining oil while maintaining a good level of suds. If suds break down during cleaning, discard dirty water and start again with more hot water and detergent. Following scrubbing, rinse cylinder with very hot, clear water, dry it completely, and apply a light coating of engine oil to prevent rusting.

## Measuring Piston-to-Bore Clearance Piston Detail

### Piston Details

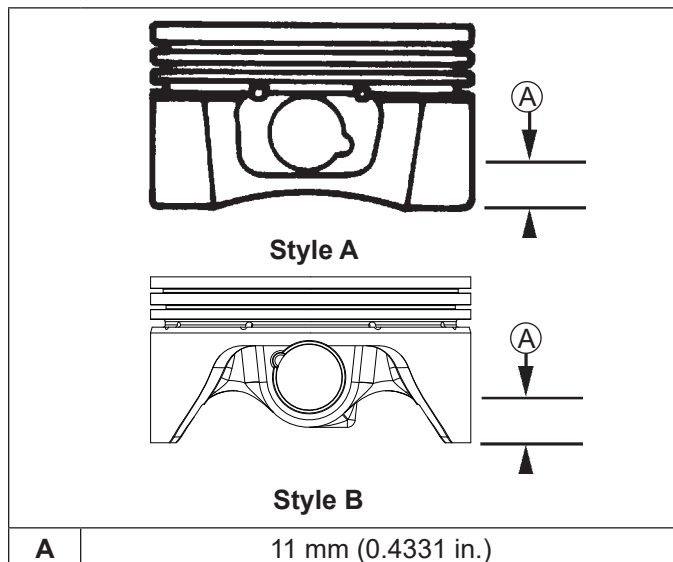

**NOTE:** Do not use a feeler gauge to measure piston-to-bore clearance; it will yield inaccurate measurements. Always use a micrometer.

Before installing piston into cylinder bore, it is necessary that clearance be accurately checked. This step is often overlooked, and if clearances are not within specifications, engine failure will usually result.

Use following procedure to accurately measure piston-to-bore clearance:

1. Use a micrometer and measure diameter of piston above bottom of piston skirt and perpendicular to piston pin.
2. Use an inside micrometer, telescoping gauge, or bore gauge and measure cylinder bore. Take measurement approximately 63.5 mm (2.5 in.) below top of bore and perpendicular to piston pin.
3. Piston-to-bore clearance is difference between bore diameter and piston diameter (step 2 minus step 1).

# Reassembly

## Crankcase Components

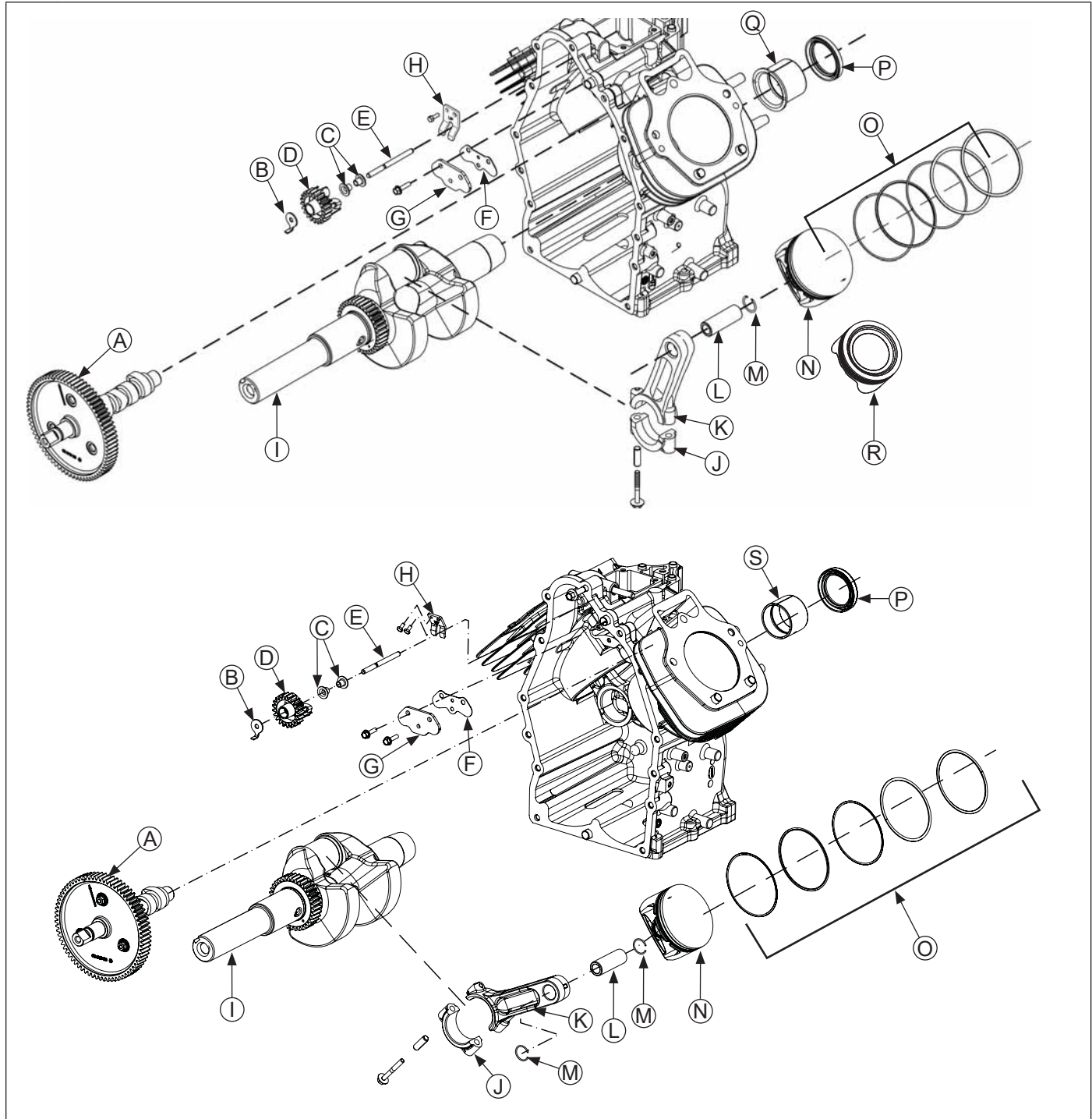

<b>A</b>	Camshaft	<b>B</b>	Locking Tab	<b>C</b>	Regulating Pin	<b>D</b>	Governor Gear
<b>E</b>	Cross Shaft	<b>F</b>	Lifter Feed Cover Gasket	<b>G</b>	Lifter Feed Cover	<b>H</b>	Governor Yoke
<b>I</b>	Crankshaft	<b>J</b>	Connecting Rod End Cap	<b>K</b>	Connecting Rod	<b>L</b>	Piston Pin
<b>M</b>	Piston Pin Retainer	<b>N</b>	Piston (Style A)	<b>O</b>	Piston Ring Set	<b>P</b>	Oil Seal
<b>Q</b>	Crankshaft Thrust Bearing (Flange Flywheel)	<b>R</b>	Piston (Style B)	<b>S</b>	Crankshaft Non-Thrust Bearing (Flywheel)		

**NOTE:** Make sure engine is assembled using all specified torque values, torque sequences, and clearances. Failure to observe specifications could cause severe engine wear or damage. Always use new gaskets. Apply a small amount of oil to threads of critical fasteners before assembly, unless a sealant or Loctite® is specified or preapplied.

Make sure all traces of any cleaner are removed before engine is assembled and placed into operation. Even small amounts of these cleaners can quickly break down lubricating properties of engine oil.

Check closure plate, crankcase, cylinder heads, and valve covers to be certain all old gasket material has been removed. Use gasket remover, lacquer thinner, or paint remover to remove any remaining traces. Clean surfaces with isopropyl alcohol, acetone, lacquer thinner, or electrical contact cleaner.

### Install Flywheel End Oil Seal

1. Make sure seal bore of crankcase is clean and free of any nicks or burrs.
2. Apply a light coat of P80 Emulsion Lubricant (refer to Tools and Aids) to outside diameter of oil seal.
3. Install oil seal into crankcase using a seal driver. Make sure oil seal is installed straight and true in bore and tool bottoms against crankcase.

### Install Lifter Feed Chamber Gaskets and Cover

1. Install lifter feed chamber gasket, followed by lifter feed cover over lifter feed chamber. If used, position breather baffle on top of parts with winged offset down.
2. Install 3 screws. Make sure all parts are properly aligned. Torque screws to 7.7 N·m (68 in. lb.).

### Install Crankshaft Bearing (flywheel)

If bearing was removed in servicing, install a new bearing using an arbor press and driver.

1. Make sure crankcase bore for bearing is clean, dry and free of nicks or burrs.
2. Press flywheel side main bearing in place with notch oriented in 12 o'clock position using an arbor press and driver. Make sure bearing is fully seated against flange and oil feed hole is open in crankcase.
3. Apply a light coat of clean engine oil to inner surface of bearing and oil seal.

## Install Governor Shafts, Seal, and Governor Gear

### Governor Components and Details

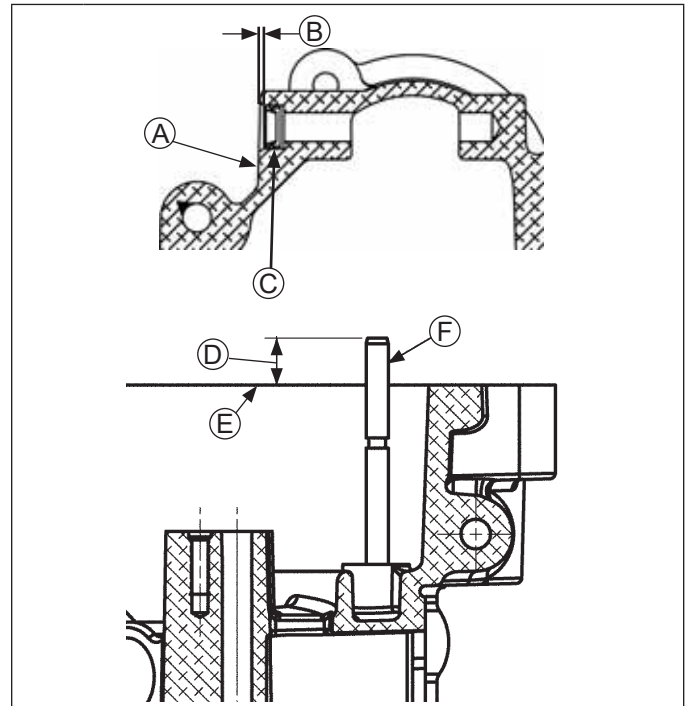

<b>A</b>	Crankcase Surface	<b>B</b>	Seal Depth 1.5-2.0 mm (0.059-0.078 in.)
<b>C</b>	Oil Seal	<b>D</b>	12.66 mm (0.498 in.)
<b>E</b>	Crankcase Surface	<b>F</b>	Governor Gear Shaft

If governor shafts, seal, and/or governor gear were removed, reassemble as follows.

1. Lightly coat outer diameter of governor cross shaft seal with P80 Emulsion Lubricant (refer to Tools and Aids). Install seal into crankcase to depth shown.
2. If governor gear shaft was removed, press or lightly tap replacement shaft into closure plate to depth shown.
3. Lubricate governor cross shaft bearing surfaces in crankcase with engine oil. Insert governor cross shaft end with flat cutout where governor yoke is secured, into crankcase and position shaft so that flat part is visible (up).
4. Attach governor yoke to cross shaft so curved section is up as marked. Secure with 2 screws. If a thread locking compound is not preapplied, apply a small amount of Loctite® 266™ Threadlocker or equivalent, to screw threads before installing. Torque screws to 2.2 N·m (20 in. lb.).
5. Install first regulating pin with head down so it will contact yoke. Install governor gear with second regulating pin and flyweight assembly in/down onto governor shaft until it locks into position. Apply a small amount of grease to locking tab thrust washer and install on top of governor gear so tang is facing up in 6 o'clock position.

# Reassembly

## Install Crankshaft

Carefully slide flywheel end of crankshaft through bearing in crankcase.

## Install Connecting Rods with Pistons and Rings

### Piston Details

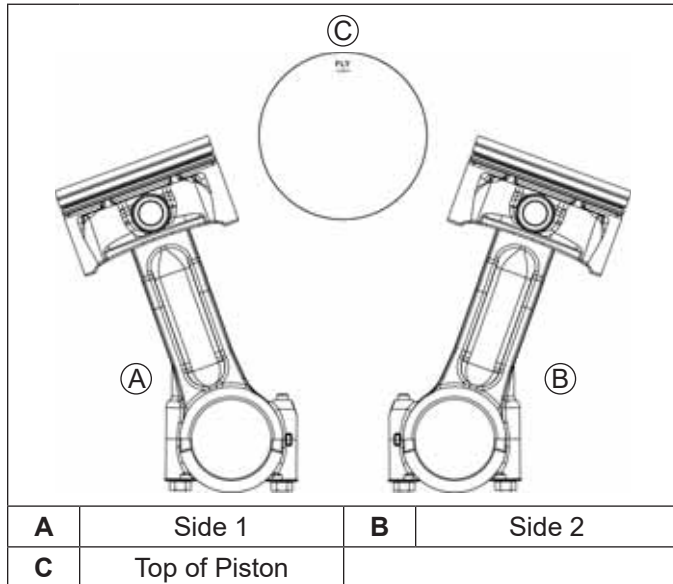

NOTE: Cylinders are numbered on crankcase. Make sure to install piston, connecting rod and end cap into appropriate cylinder bore as previously marked at disassembly. Do not mix end caps and connecting rods.

NOTE: Proper orientation of piston/connecting rod assemblies inside engine is extremely important. Improper orientation can cause extensive wear or damage. Be certain pistons and connecting rods are assembled exactly as shown.

1. If piston rings were removed, refer to Disassembly/Inspection and Service procedure to install new rings.
2. Lubricate cylinder bore, piston, and piston rings with engine oil. Compress rings of piston side 1 using a piston ring compressor.
3. Lubricate crankshaft journals and connecting rod bearing surfaces with engine oil.
4. Make sure FLY stamping on piston is facing toward flywheel side of engine. Use a hammer with a rubber grip and gently tap piston into cylinder. Be careful oil ring rails do not spring free between bottom of ring compressor and top of cylinder.
5. Install inner rod cap to connecting rod using screws. Torque screws in increments to 11.6 N·m (103 in. lb.). Illustrated instructions are provided in service rod package.

Align chamfer of connecting rod with chamfer of its mating end cap. When installed, flat faces of connecting rods should face each other. Faces with raised rib should be toward outside.

6. Repeat this procedure for other connecting rod and piston assembly.

## Install Camshaft

1. Liberally apply camshaft lubricant to each cam lobe. Lubricate camshaft bearing surfaces of crankcase and camshaft with engine oil.
2. Position timing mark of crankshaft gear at 12 o'clock position.
3. Slide camshaft into bearing surface of crankcase, positioning timing mark of camshaft gear at 6 o'clock position. Make sure camshaft gear and crankshaft gear mesh, with both timing marks aligned.

### Determining Camshaft End Play

1. Place a new closure plate gasket into position on crankcase.
2. Position camshaft end play checking tool over camshaft. Use a feeler gauge to check end play between camshaft and end play checking tool. Camshaft endplay should be between 0.3/1.3 mm (0.011/0.051 in.).
3. No shim is typically used from factory. However, if camshaft end play is not within specified range, remove checking tool and shim as necessary.

Several color coded shims are available:

White: 0.69215/0.73025 mm (0.02725/0.02875 in.)

Blue: 0.74295/0.78105 mm (0.02925/0.03075 in.)

Red: 0.79375/0.83185 mm (0.03125/0.03275 in.)

Yellow: 0.84455/0.88265 mm (0.03325/0.03475 in.)

Green: 0.89535/0.99345 mm (0.03525/0.03675 in.)

Gray: 0.94615/0.98425 mm (0.03725/0.03875 in.)

Black: 0.99695/1.03505 mm (0.03925/0.04075 in.)

4. Reinstall end play checking tool and recheck end play.

## Breather/Closure Plate/Oil Reservoir Components

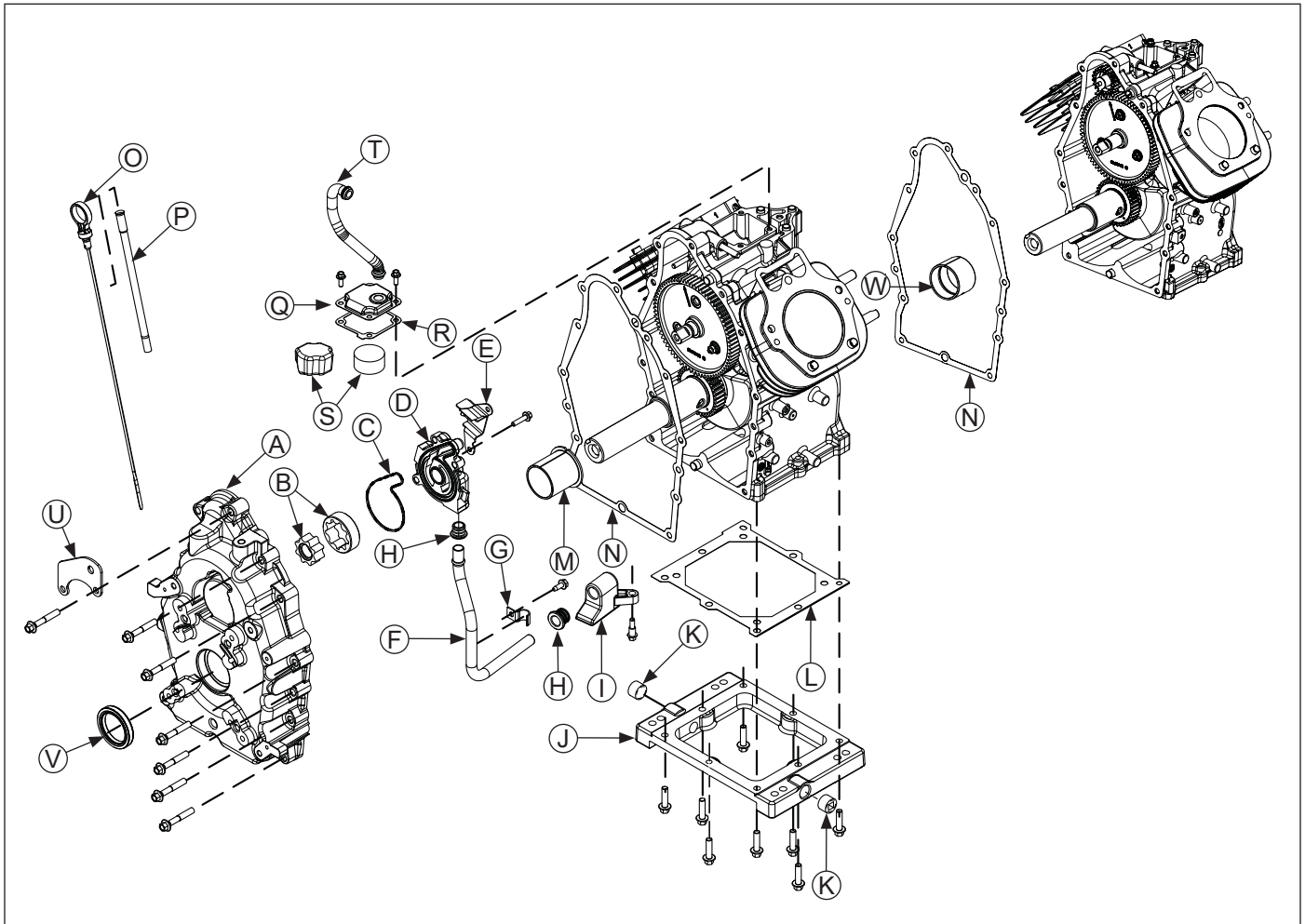

<b>A</b>	Closure Plate	<b>B</b>	Gerotor Gears	<b>C</b>	Oil Pump O-ring	<b>D</b>	Oil Pump Housing
<b>E</b>	Relief Valve Baffle	<b>F</b>	Pickup Tube	<b>G</b>	Clamp	<b>H</b>	Inlet Seal
<b>I</b>	Pickup Screen	<b>J</b>	Oil Reservoir	<b>K</b>	Drain Plug	<b>L</b>	Gasket
<b>M</b>	Crankshaft Thrust Bearing (Flange PTO)	<b>N</b>	Closure Plate Gasket	<b>O</b>	Dipstick	<b>P</b>	Dipstick Tube
<b>Q</b>	Breather Assembly	<b>R</b>	Breather Gasket	<b>S</b>	Filter	<b>T</b>	Breather Hose
<b>U</b>	Lifting Strap	<b>V</b>	Oil Seal	<b>W</b>	Crankshaft Non-Thrust Bearing (PTO)		

### Install Closure Plate Crankshaft Bearing (PTO) and Oil Seal

If bearing was removed in servicing, install a new bearing using an arbor press and driver.

1. Make sure closure plate bore for bearing is clean, dry and free of nicks or burrs.
2. Press closure plate side main bearing in place with notch oriented in 12 o'clock position using an arbor press and driver. Make sure bearing is fully seated against flange.

# Reassembly

## Oil Seal Details

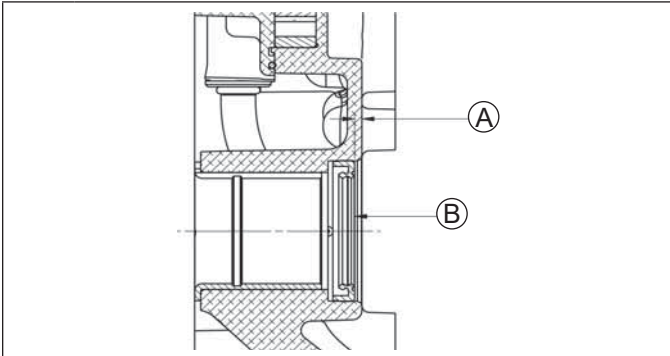

<b>A</b>	3.0 mm (0.118 in.)	<b>B</b>	Oil Seal
----------	--------------------	----------	----------

1. Check to make sure there are no nicks or burrs in crankshaft seal bore of closure plate.
2. Apply a light coat of P80 Emulsion Lubricant (refer to Tools and Aids) to outside diameter of oil seal.
3. Install oil seal into closure plate using a seal driver. Make sure oil seal is installed straight and true in bore to depth shown.
4. Apply a light coat of clean engine oil to inner surface of bearing and oil seal.

## Oil Pump Assembly

Oil pump is mounted inside closure plate. If service was required and oil pump was removed, refer to Disassembly/Inspection and Service procedure.

## Install Closure Plate Assembly

### Torque Sequence

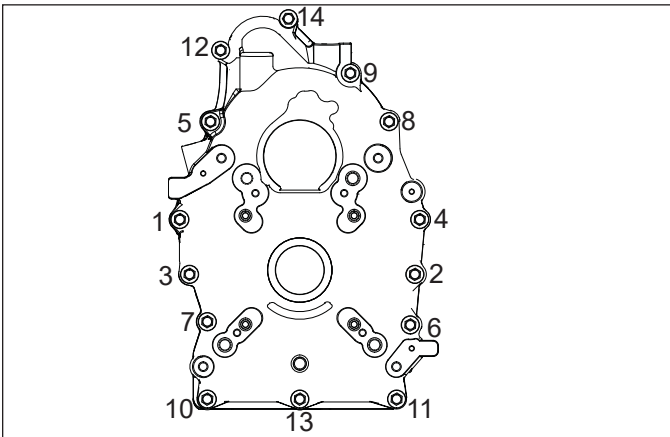

1. Make sure sealing surfaces of closure plate and crankcase are clean, dry, and free of any nicks or burrs. Install a new O-ring in closure plate.
2. Install a new closure plate gasket onto crankcase.

3. Make sure oil pump is installed and oil pickup tube faces outward at lower end.
4. Ensure end of tabbed washer on governor gear is positioned outward in 6 o'clock position inside crankcase.
5. Orient flat of oil pump gear to match position of flat on camshaft. Then install closure plate to crankcase. Carefully seat camshaft and crankshaft into their mating bearings. Rotate crankshaft slightly to help oil pump and governor gears mesh.
6. Install screws securing closure plate to crankcase. Torque screws in sequence shown to 25.6 N·m (227 in. lb.).

## Install Oil Pickup Screen

Apply a small amount of oil to grommet of pickup screen and insert it onto lower end of pickup tube within crankcase. Secure pickup to boss on bottom of crankcase. Torque mounting screw to 9.3 N·m (82 in. lb.) into new holes and 7.7 N·m (68 in. lb.) into used holes.

## Install Oil Reservoir

### Torque Sequence

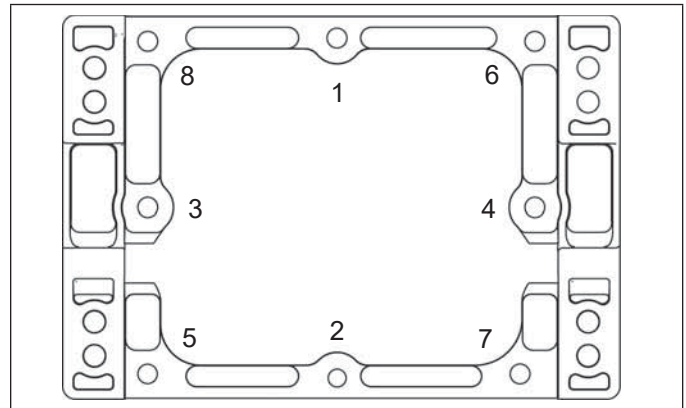

1. Use bolts with heads removed, or a similar item as temporary alignment pins and install into 2 center holes on ends.
2. Install a new oil reservoir gasket onto bottom of crankcase using alignment pins. Notched side of gasket must be towards flywheel.
3. Install oil reservoir onto crankcase and temporary alignment pins. Flywheel side is indicated on cover. Install and finger tighten screws. Remove alignment pins and install remaining screws. Torque screws in sequence shown to 25.6 N·m (227 in. lb.).

## Check Crankshaft End Play

Set engine on base and use a dial indicator to check crankshaft end play to 0.30/1.50 mm (0.011/0.059 in.) for flange thrust bearing and 0.20/0.94 mm (0.008/0.037 in.) for non-thrust bearing.

## Breather Components

Used on Serial No. 37070xxxxx and Below

Used on Serial No. 37071xxxxx and Higher

<b>A</b>	Breather Hose	<b>B</b>	Flange Nuts	<b>C</b>	Breather	<b>D</b>	Gasket
<b>E</b>	Screw	<b>F</b>	Baffle	<b>G</b>	Filter	<b>H</b>	Adapter
<b>I</b>	Studs						

### Install Breather Assembly

1. Make sure sealing surfaces of crankcase and breather cover are clean and free of any nicks or burrs. Do not scrape surfaces, as this could result in leakage. Install breather mounting studs into crankcase if removed during disassembly.
2. Install breather chamber gasket as shown. Assemble and install breather assembly components as illustrated. Make sure filter does not extend above top surface and all parts are properly aligned.
3. Install M5 nuts onto studs, then torque using sequence shown to 12.4 N·m (110 in. lb.).
4. Lightly oil lower end of breather hose and install into hole in breather assembly. Cover should be situated between 2 raised rings of hose.

# Reassembly

## Cylinder Head Components

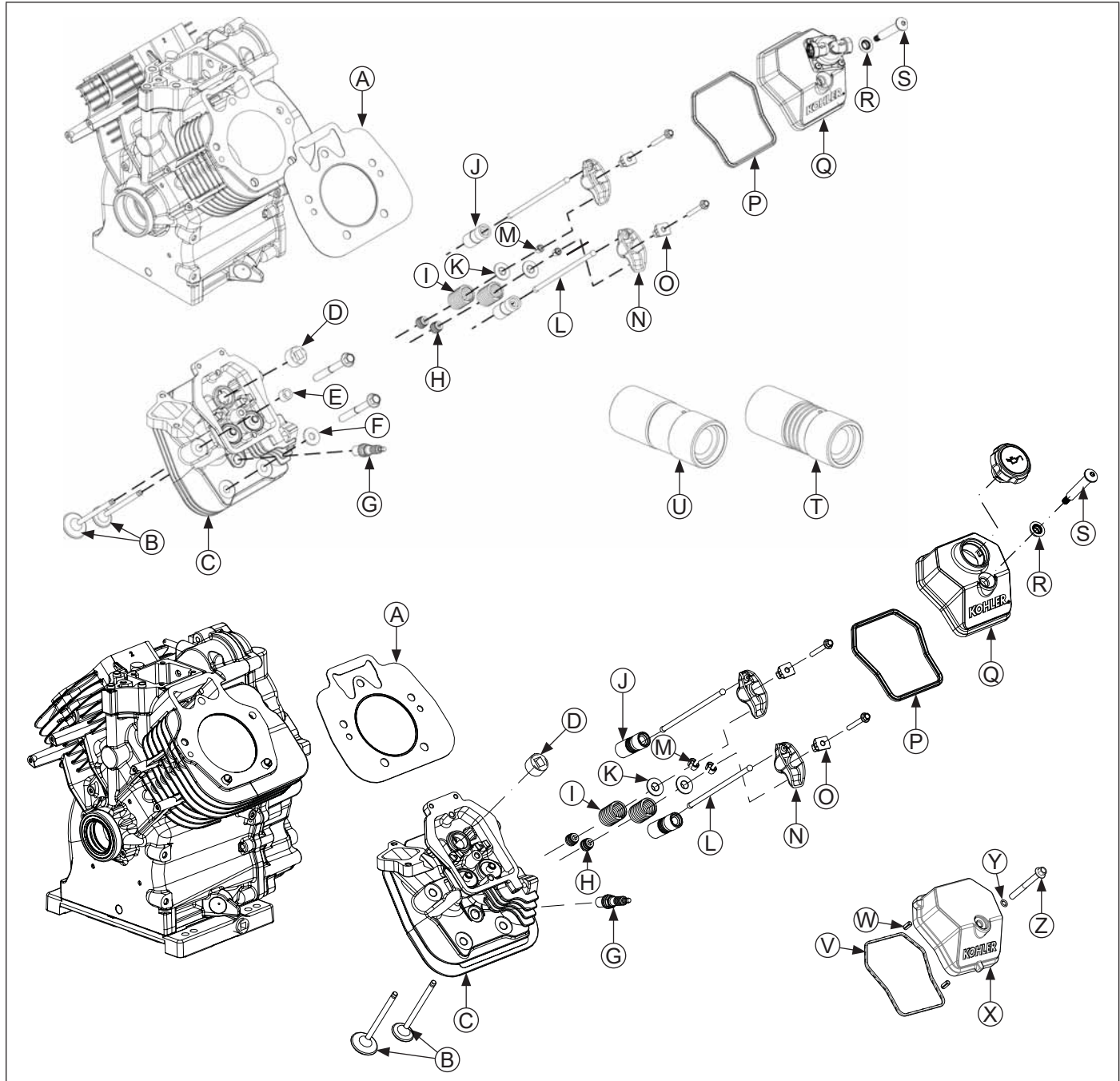

A	Gasket	B	Valve	C	Cylinder Head	D	Pipe Plug
E	Spacer	F	Washer	G	Spark Plug	H	Valve Stem Seal
I	Valve Spring	J	Hydraulic Lifter	K	Valve Spring Retainer	L	Push Rod
M	Valve Spring Keeper	N	Rocker Arm	O	Rocker Arm Pivots	P	Valve Cover Seal (Plastic Valve Cover)
Q	Valve Cover (Plastic)	R	Grommet (Plastic Valve Cover)	S	Screw (Plastic Valve Cover)	T	Hydraulic Lifter Style A (Ribbed)
U	Hydraulic Lifter Style B (Smooth)	V	Valve Cover Seal (Aluminum Valve Cover)	W	Roll Pin (Aluminum Valve Cover)	X	Valve Cover (Aluminum)
Y	O-Ring (Aluminum Valve Cover)	Z	Screw (Aluminum Valve Cover)				

## Install Hydraulic Lifters

NOTE: Hydraulic lifters should always be installed in same position as they were disassembled. Exhaust lifters are located on output shaft side of engine while intake lifters are located on fan side of engine. Cylinder numbers are embossed on top of crankcase and each cylinder head.

1. Refer to Disassembly/Inspection and Service for lifter preparation (bleed down) procedures.
2. Apply camshaft lubricant to bottom surface of each lifter. Lubricate hydraulic lifters and lifter bores in crankcase with engine oil.
3. Note mark or tag identifying hydraulic lifters as either intake or exhaust and cylinder 1 or cylinder 2. Install hydraulic lifters into their appropriate location in crankcase. Do not use a magnet.

## Valve Stem Seals

These engines use valve stem seals on intake and exhaust valves. Always use new seals whenever valves are removed from cylinder head. Seals should also be replaced if worn or damaged. Never reuse an old seal.

## Assemble Cylinder Heads

Prior to installation, lubricate all components with engine oil, paying particular attention to lip of valve stem seal, valve stems, and valve guides. Install in order listed below using a valve spring compressor.

- Intake and exhaust valves.
- Valve spring retainers.
- Valve springs.
- Valve spring keepers.
- Valve stem seals.

## Install Cylinder Heads

### Torque Sequence

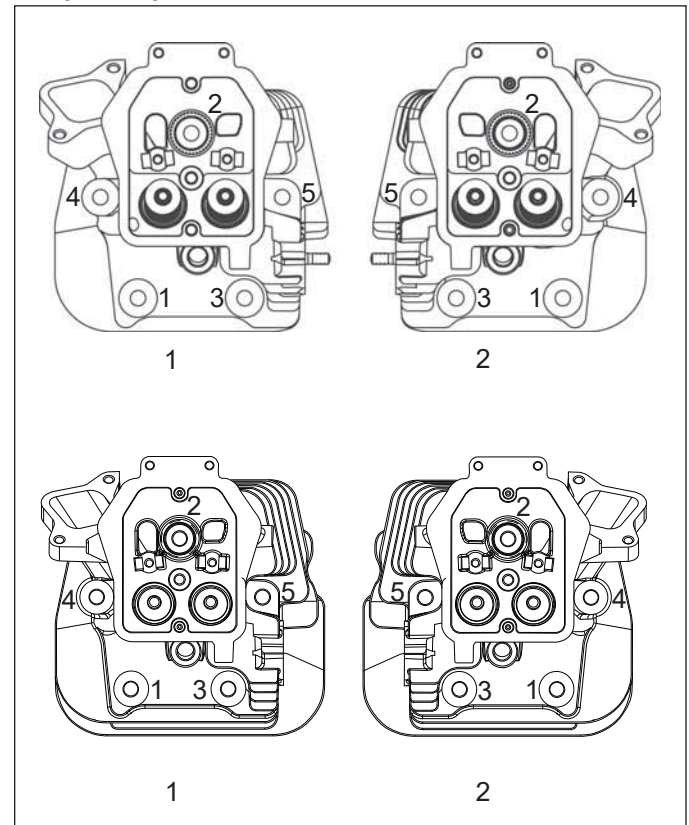

NOTE: Match numbers embossed on cylinder heads and crankcase.

1. Check to make sure there are no nicks or burrs on sealing surfaces of cylinder head or crankcase.
2. Check dowel pins are in place in 2 lower locations, and install a new cylinder head gasket, (printed side up).
3. Install cylinder head. Make sure head is flat on gasket and dowel pins. Install a flat washer on screws in locations 1 and 3. Install spacer followed by a flat washer on screw in location 5. Start 5 screws.
4. Torque screws in 2 stages, first to 23.7 N·m (210 in. lb.), finally to 46.9 N·m (415 in. lb.) following sequence shown.
5. Repeat procedure for opposite cylinder.
6. Make sure threads of pipe plugs for cylinder heads are clean and dry. Install a plug into each cylinder head above screw on location 2 and torque to 28.5 N·m (252 in. lb.).

# Reassembly

## Install Push Rods and Rocker Arms

NOTE: Push rods should always be installed in same position as before disassembly.

1. Note mark or tag identifying push rod as either intake or exhaust and cylinder 1 or 2. Dip ends of push rods in engine oil and install, making sure each push rod ball seats in its hydraulic lifter socket.
2. Apply grease to contact surfaces of rocker arms and rocker arm pivots. Install rocker arms and rocker arm pivots on cylinder head 1, and start 2 screws.
3. Rotate crankshaft to establish TDC on compression stroke. Keyway should be aligned with cylinder 1.
4. Torque screws to the appropriate torque for style of screw.

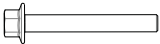
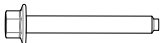
	15.5 N·m (137 in. lb.)
	11.9 N·m (105 in. lb.)

5. If push rods were not already seated, use a spanner wrench or rocker arm lifting tool, to lift rocker arms and position push rods underneath.
6. From PTO end, rotate crankshaft 270° (3/4 turn) counterclockwise and align crankshaft keyway with cylinder 2. This now puts cylinder 2 at TDC on compression stroke.
7. Repeat steps 1-5 for remaining cylinder. Do not interchange parts from cylinder heads.
8. Rotate crankshaft to check for free operation of valve train. Check clearance between valve spring coils at full lift. Minimum allowable clearance is 0.25 mm (0.010 in.).

## Install Valve Covers

### Plastic Valve Covers

1. Make sure sealing surfaces are clean and free of any nicks or burrs.
2. Install and properly seat seal onto each valve cover.
3. Install valve covers on same side as they were originally installed.
4. Install a new grommet on each valve cover mounting screw. Start each screw into hole.
5. Check position of each cover and seal, then torque screws to 13.6 N·m (120 in. lb.).
6. Install oil fill cap onto valve cover (if equipped).

### Aluminum Valve Covers

NOTE: A new valve cover seal must be installed whenever an aluminum valve cover is removed from cylinder head.

1. Make sure sealing surfaces are clean and free of any nicks or burrs.
2. Install and properly seat a new seal into each valve cover.
3. Apply clean engine oil under screw head and on threads of each valve cover screw, O-ring, and new valve cover seal.
4. Install valve covers on same side as they were originally installed and tighten screws.
5. Check position of valve cover and seal.  
Into New Head: Torque screw to 26 N·m (230 in. lb.) to ensure seal seats in valve cover groove. Back off screw and then torque screw again to 18.1 N·m (160 in. lb.).  
Into Used Head: Torque screw to 16.4 N·m (145 in. lb.) to ensure seal seats in valve cover groove. Back off screw and then torque screw again to 16.4 N·m (145 in. lb.).

## Install Spark Plugs

1. Check gap using wire feeler gauge. Adjust gap to 0.76 mm (0.030 in.).
2. Install plug into cylinder head.
3. Torque plug to 27 N·m (20 ft. lb.).

## Oil Cooler/Filter Components

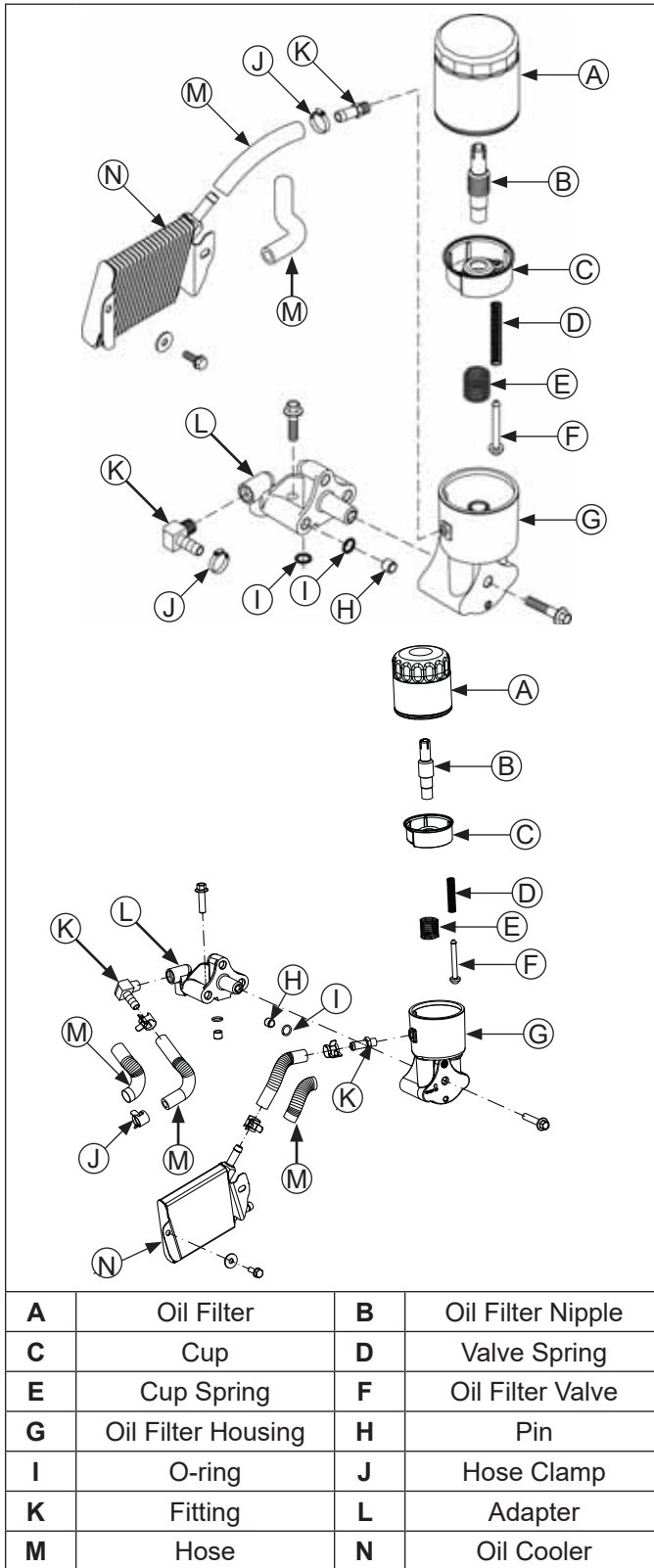

### Install Oil Filter Adapter

1. Make sure all sealing surfaces are clean and dowel pins are in place on crankcase adapter surface. Carefully install a new O-ring around each dowel pin. Then install new O-rings onto dowel pins of oil filter adapter.
2. Install oil filter adapter onto crankcase. Install and torque M8 capscrew to 23.7 N·m (210 in. lb.).

### Install Intake Manifold

#### Torque Sequence

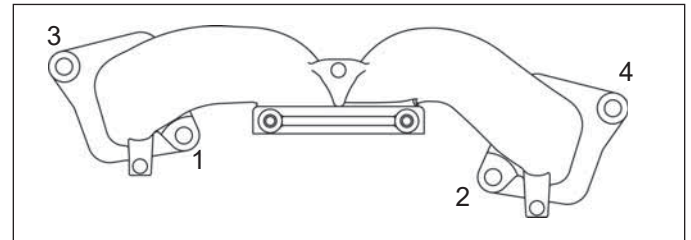

1. Install new intake manifold gaskets so notched section is inward and points toward flywheel side.
2. Mount intake manifold to cylinder heads. Make sure gaskets remain in proper position. Torque screws in 2 stages using sequence shown, first to 16.9 N·m (150 in. lb.), finally to 22.6 N·m (200 in. lb.).
3. Install carburetor mounting studs into intake manifold if previously removed. Use nuts, locked flange to flange, and tighten each stud until bottomed/tight.

### Install Oil Filter Housing Assembly

Reassemble oil filter housing if disassembled previously.

#### Reassembly

1. Install small spring onto rubber valve, and insert small end through corresponding hole in cup until properly seated.
2. Install larger spring into filter housing.
3. Insert oil filter cup, aligning cutout with corresponding section in housing.
4. Install nipple in housing and torque to 17.8 N·m (158 in. lb.).

#### Installation

1. Make sure all sealing surfaces are clean and all dowel pins are in position. Install or check new O-rings are around all oil filter adapter dowel pins.
2. Install oil filter housing assembly to adapter and secure with M8 screw. Make sure housing is flat on crankcase and all O-rings remain in position. Torque screw to 23.7 N·m (210 in. lb.).
3. Oil filter may be installed now or upon completion of engine assembly.

# Reassembly

## Flywheel/Ignition Components

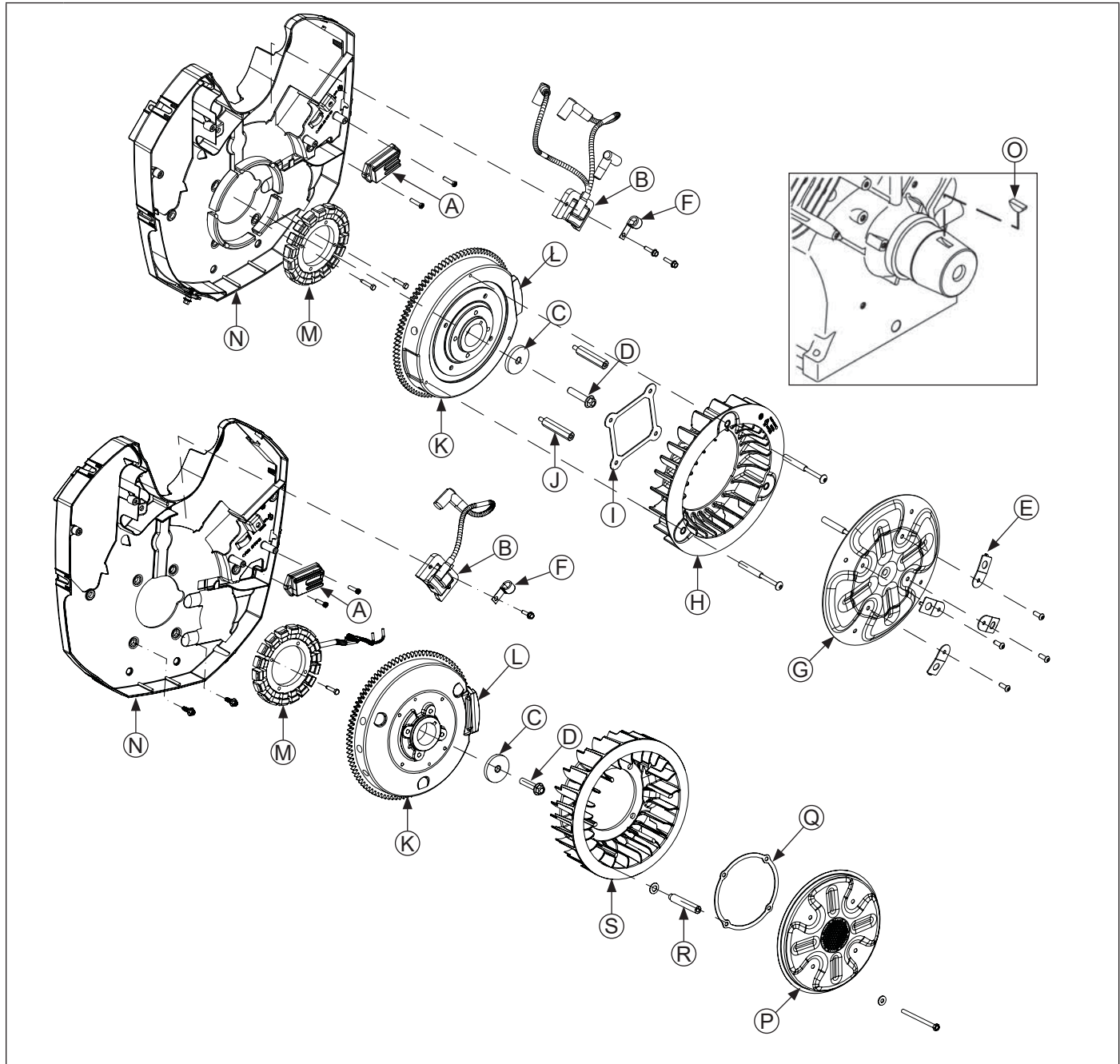

<b>A</b>	Rectifier-Regulator	<b>B</b>	Ignition Module	<b>C</b>	Washer	<b>D</b>	Flywheel Screw
<b>E</b>	Special Washer (Style A)	<b>F</b>	Wire Harness Clamp	<b>G</b>	Debris Screen (Style A)	<b>H</b>	Fan (Style A)
<b>I</b>	Stiffener (Style A)	<b>J</b>	Hex Stud	<b>K</b>	Flywheel	<b>L</b>	Magnet
<b>M</b>	Stator	<b>N</b>	Backing Shroud	<b>O</b>	Woodruff Key	<b>P</b>	Debris Screen (Style B)
<b>Q</b>	Support Ring (Style B)	<b>R</b>	Spacer (Style B)	<b>S</b>	Fan (Style B)		

## Install Backing Shroud Assembly

NOTE: New hose clamps are recommended for reassembly, or if clamps have been loosened (expanded) several times to avoid leakage.

1. To aid assembly, install lower oil cooler hose onto oil filter housing prior to installing backing shroud assembly, and secure with a clamp.
2. Install backing shroud assembly and secure to crankcase with M6 screws. Torque screws in a crisscross pattern to 10.7 N·m (95 in. lb.) into new holes, or 7.3 N·m (65 in. lb.) into used holes.

## Install Stator, Wiring Harness, and Rectifier-Regulator

1. Apply pipe sealant with Teflon® (Loctite® PST® 592™ Thread Sealant or equivalent) to stator mounting holes.
2. Position stator, aligning mounting holes so leads are at bottom and toward rectifier-regulator mount on cylinder 1 side.
3. Install and torque screws to 9.3 N·m (82 in. lb.).
4. Route stator wires under molded clips in backing shroud assembly.
5. Check terminal on end of B+ charging lead to be sure locking tang is angled upward. Insert terminal into center location of connector until it locks into place.
6. Install wiring harness under molded clips in backing shroud assembly.
7. Position rectifier-regulator onto mounting posts with cooling fins up. Attach ground lead to outer screw and washer, then torque mounting screws to 2.5 N·m (22 in. lb.). Connect plug to rectifier-regulator.

## Install Flywheel

	<p><b>CAUTION</b></p>
<p>Damaging Crankshaft and Flywheel Can cause personal injury.</p>	
<p>Using improper procedures can lead to broken fragments. Broken fragments could be thrown from engine. Always observe and use precautions and procedures when installing flywheel.</p>	

NOTE: Before installing flywheel make sure crankshaft taper and flywheel hub are clean, dry, and completely free of any lubricants. Presence of lubricants can cause flywheel to be over stressed and damaged when screw is torqued to specifications.

NOTE: Make sure flywheel key is installed properly in keyway. Flywheel can become cracked or damaged if key is not properly installed.

1. Install woodruff key into crankshaft keyway. Make sure key is properly seated and parallel with shaft taper.

2. Install flywheel onto crankshaft, being careful not to shift woodruff key.
3. Install screw and washer.
4. Use a flywheel strap wrench or holding tool to hold flywheel. Torque screw to 69.8 N·m (51 ft. lb.).

## Install Fan (Style B)

NOTE: Position locating tabs on back of fan into locating holes of flywheel.

1. Install fan onto flywheel using screws (engines with plastic grass screen). Engines with a metal grass screen will leave fan loosely assembled.
2. Torque screws to 9.9 N·m (88 in. lb.).

## Install Ignition Modules

### CDI/MDI Ignition System

1. Rotate flywheel to position magnet away from ignition module bosses.
2. CDI modules are installed with spark plug lead wire from module always away from cylinder. On cylinder 1, single kill tab should be towards you. On cylinder 2, single kill tab should be away from you (in).  
MDI modules are installed with flat side out/towards you.
3. Slide modules up as far away from flywheel as possible and snug screws to hold them in position.
4. Rotate flywheel to position magnet directly under 1 ignition module.
5. Insert a 0.30 mm (0.012 in.) flat feeler gauge between magnet and ignition module. Loosen screws enough to allow magnet to pull module down against feeler gauge.
6. Torque screws to 9.7 N·m (86 in. lb.) into new holes, or 4.1 N·m (37 in. lb.) into used holes.
7. Repeat steps 4 through 6 for other ignition module.
8. Rotate flywheel back and forth, checking for clearance between magnet and ignition modules. Make sure magnet does not strike modules. Check gap with a feeler gauge and readjust if necessary. Final Air Gap 0.280/0.330 mm (0.011/0.013 in.).
9. Make sure leads are under molded clip on starter side.

### DSAI Ignition System

NOTE: DSAI modules do not require or have an air gap adjustment.

1. Install each DSAI ignition module to crankcase bosses with flat section towards flywheel and individual spade terminals out. Torque screws to 9.7 N·m (86 in. lb.) into new holes, or 4.1 N·m (37 in. lb.) into used holes.
2. Apply GE/Novaguard G661 or equivalent dielectric compound to module surface between base of terminals to create a moisture proof barrier. **Do not** put any compound inside harness connectors.

# Reassembly

## Install Cooling Fan and Debris Screen (Style A)

	<b>⚠ CAUTION</b>
	Failure to utilize or reassemble debris screen as designed could result in debris screen failure and serious personal injury.

1. Position cooling fan onto flywheel aligning mounting locations. Apply a small amount of Loctite® 243™ Threadlocker to threads and install long mounting screws. Torque screws to 10.4 N·m (92 in. lb.).
2. Apply a small amount of Loctite® 243™ Threadlocker to external threaded section, (unless new parts with preapplied locking compound are being used). Thread debris screen hex studs into mounting holes in flywheel. Torque each stud to 21.5 N·m (190 in. lb.).
3. Install stiffener followed by metal debris screen onto studs. Secure with special washers and mounting screws using Loctite® 243™ Threadlocker on threads. Torque hex flange screws to 20.3 N·m (180 in. lb.) and button head cap screws to 9.9 N·m (88 in. lb.).

## Install Metal Debris Screen (Style B)

### Spring Washer Details

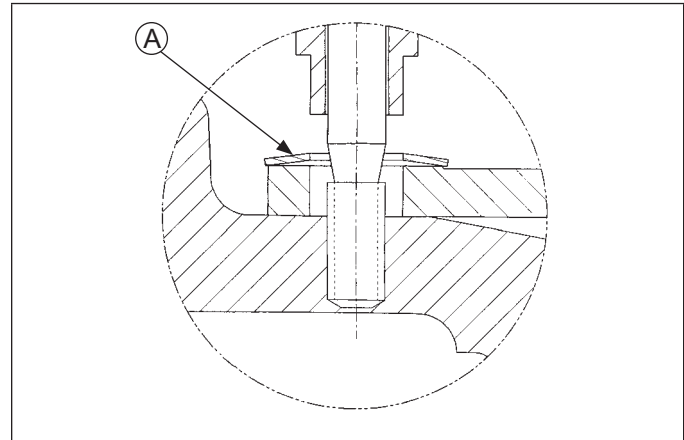

<b>A</b>	Spring Washer
----------	---------------

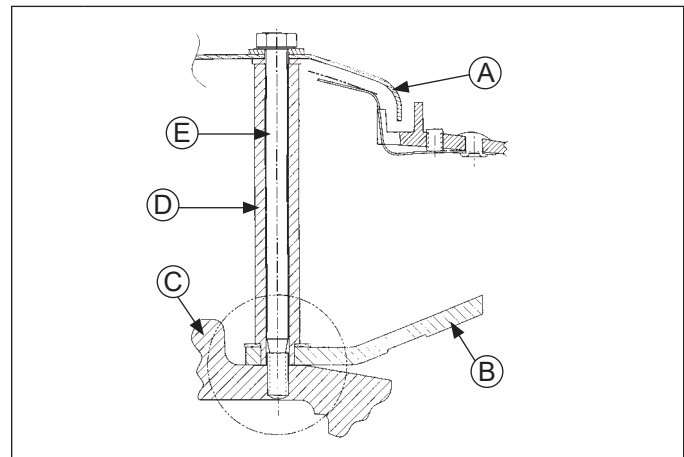

<b>A</b>	Metal Debris Screen	<b>B</b>	Fan
<b>C</b>	Flywheel	<b>D</b>	Spacer
<b>E</b>	Hex Bolt		

1. Verify locating tabs on back of fan are inserted into locating holes on flywheel.
2. To assist assembly, find intake manifold studs with M6 thread at least 100 mm in length to be used as guide pins. Insert intake manifold studs through cooling fan mounting holes and thread them 4 or 5 turns into flywheel.
3. Install a spring washer on each stud with concave side down toward cooling fan.
4. Install a spacer on each stud with stepped end down. Smaller diameter should extend through spring washer and fan, so tip is resting on flywheel, and shoulder is resting on spring washer
5. Install support ring on studs, so it is resting on spacers. Then install metal screen on top of support ring.
6. Install a plain washers on each of screws. Apply Loctite® 242® to screw threads.
7. Carefully remove studs and replace with screws. Torque screws to 9.9 N·m (88 in. lb.). Repeat procedure for other studs and screws.

## External Engine Components

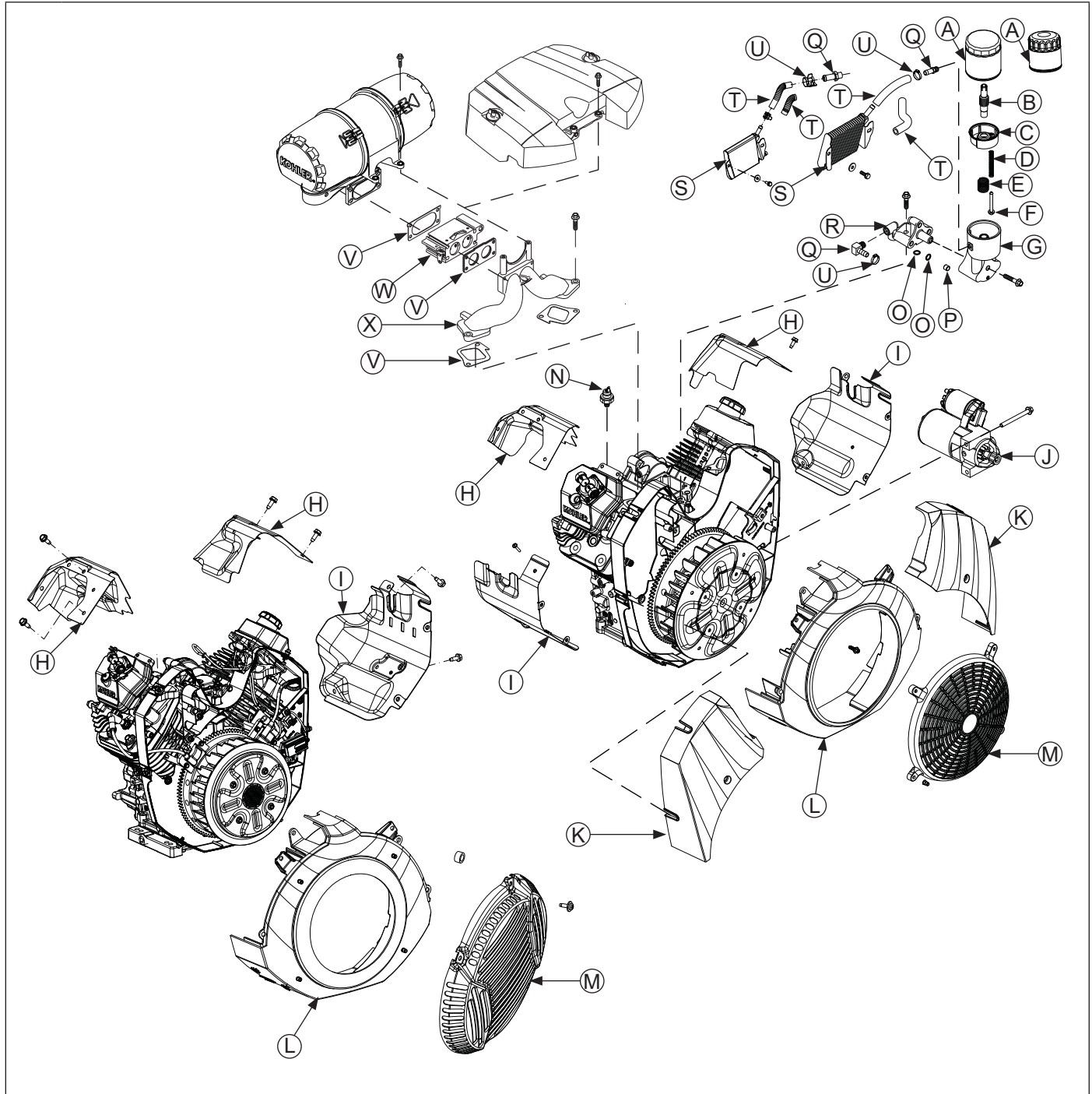

<b>A</b>	Oil Filter	<b>B</b>	Oil Filter Nipple	<b>C</b>	Oil Filter Cup	<b>D</b>	Valve Spring
<b>E</b>	Cup Spring	<b>F</b>	Valve	<b>G</b>	Oil Filter Housing	<b>H</b>	Valley Baffle
<b>I</b>	Outer Cylinder Baffle	<b>J</b>	Electric Starter	<b>K</b>	Cylinder Shroud	<b>L</b>	Blower Housing
<b>M</b>	Fixed Guard	<b>N</b>	Oil Sentry™	<b>O</b>	O-ring	<b>P</b>	Pin
<b>Q</b>	Fitting	<b>R</b>	Oil Filter Adapter	<b>S</b>	Oil Cooler	<b>T</b>	Hose
<b>U</b>	Hose Clamp	<b>V</b>	Gasket	<b>W</b>	Carburetor	<b>X</b>	Intake Manifold

# Reassembly

## Install Outer Cylinder Baffles

1. Install outer cylinder baffles. Make sure spark plug lead is routed through corresponding opening in each baffle. Start each screw. Torque M6 shoulder screws going through backing shroud assembly into extruded holes in baffles to 2.5 N·m (22 in. lb.) into new holes, or 2.0 N·m (18 in. lb.) into used holes.
2. Torque M6 screws going into cylinder head and crankcase to 10.7 N·m (95 in. lb.) for new holes, or 7.3 N·m (65 in. lb.) for used holes.

## Install Oil Cooler

1. Connect hoses between oil filter adapter and oil cooler. Secure with new clamps.
2. Align oil cooler with bosses in backing shroud assembly. Secure screws and washers to 2.3 N·m (21 in. lb.).

## Install Electric Starter

1. Install electric starter motor using screws.
2. Torque screws to 16.0 N·m (142 in. lb.).
3. Connect leads to solenoid.

## Install Valley Baffles

1. Install valley baffles and secure with mounting screws. Lower section should fit under outer baffle. Torque M6 screws going into cylinder head to 10.7 N·m (95 in. lb.) for new holes, or 7.3 N·m (65 in. lb.) for used holes. Start upper M6 screws only if main control bracket rear supports attach to these screws.
2. Torque M6 screw going into lower blower housing mounting clip to 2.5 N·m (22 in. lb.).

## Install Carburetor



### **⚠ WARNING**

Explosive Fuel can cause fires and severe burns.

Do not fill fuel tank while engine is hot or running.

Gasoline is extremely flammable and its vapors can explode if ignited. Store gasoline only in approved containers, in well ventilated, unoccupied buildings, away from sparks or flames. Spilled fuel could ignite if it comes in contact with hot parts or sparks from ignition. Never use gasoline as a cleaning agent.

1. Install a new carburetor gasket onto intake manifold with tab up. Make sure all holes align and are open.
2. Attach choke return spring and bracket to front hole in choke lever on carburetor.
3. Connect throttle and choke linkages to carburetor if they were previously disconnected. Install carburetor with linkages attached as an assembly.
4. Connect fuel line to carburetor inlet and secure with a clamp.

## Control Bracket Components

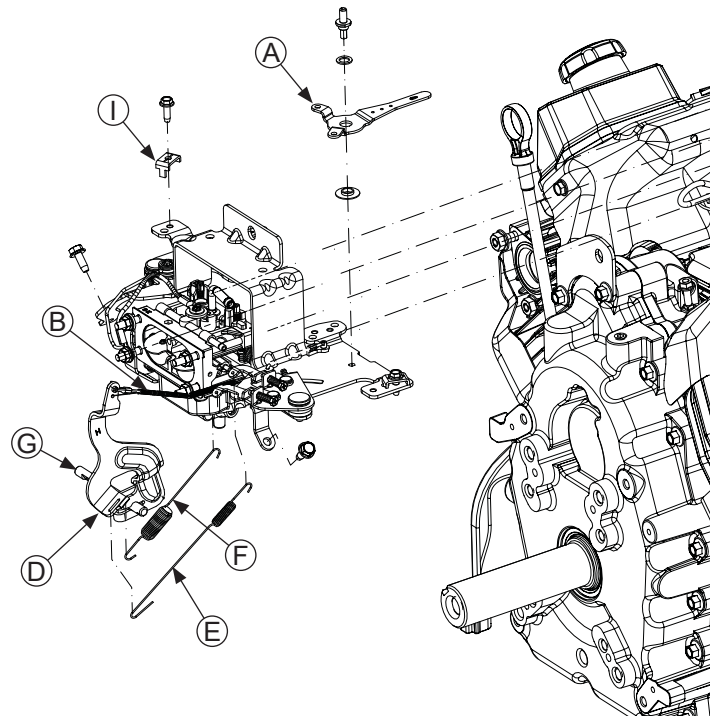
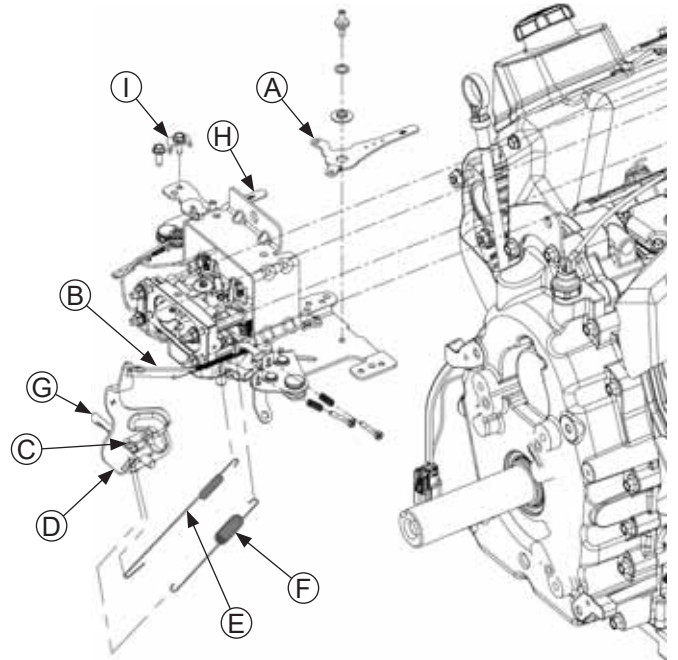
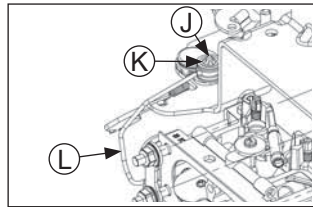
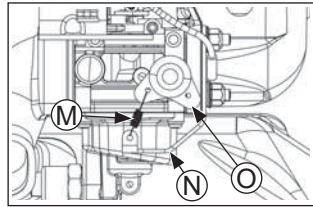

<b>A</b>	Throttle Lever	<b>B</b>	Throttle Linkage	<b>C</b>	Nut	<b>D</b>	Governor Arm
<b>E</b>	Governor Spring	<b>F</b>	Governed Idle Spring	<b>G</b>	Cross Shaft	<b>H</b>	Governor Lever
<b>I</b>	Choke Cable Clamp	<b>J</b>	Control Pivot Pin	<b>K</b>	Pal Nut	<b>L</b>	Choke Linkage
<b>M</b>	Choke Return Spring	<b>N</b>	Choke Bracket	<b>O</b>	Choke Lever		

### Install Governor Lever

Install governor lever onto governor shaft and connect throttle linkage with black clip. Do not tighten governor lever at this time.

# Reassembly

## Install Control Bracket and Air Cleaner Assembly

### Torque Sequence

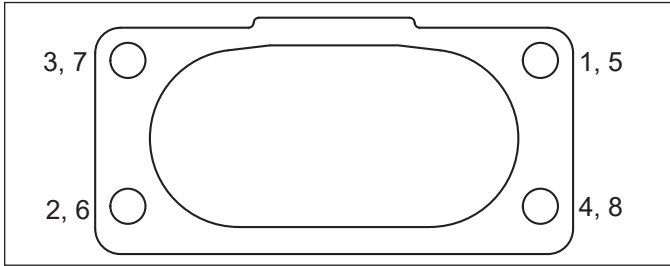

NOTE: Low-profile air cleaner is installed similarly to Heavy-duty air cleaner.

1. Position control bracket assembly onto 2 intake manifold bosses. Align rear supports with top valley baffle/cylinder head mounting screw locations and install screws, but do not fully tighten.
2. Connect choke link to control pivot pin. Reinstall washer and secure with a new push-on pal nut.
3. Install a new air cleaner elbow gasket onto carburetor mounting studs.
4. Slide air cleaner assembly onto carburetor mounting studs. Align forward mounting holes in base with mounting holes/bosses of intake manifold and control bracket. Attach ground lead under nut as originally installed. Install remaining nuts and start screws. Install rear mounting screws into valley baffle/cylinder head. Check positions of all parts then torque nuts to 11.3 N·m (100 in. lb.) in sequence shown and screws to 11.3 N·m (100 in. lb.).
5. Connect breather hose to fitting on air cleaner outlet and connect fuel solenoid lead.
6. Connect formed vent hose to air cleaner housing and vent port on carburetor.

## Install Throttle and Choke Linkages

### Cable Control Details

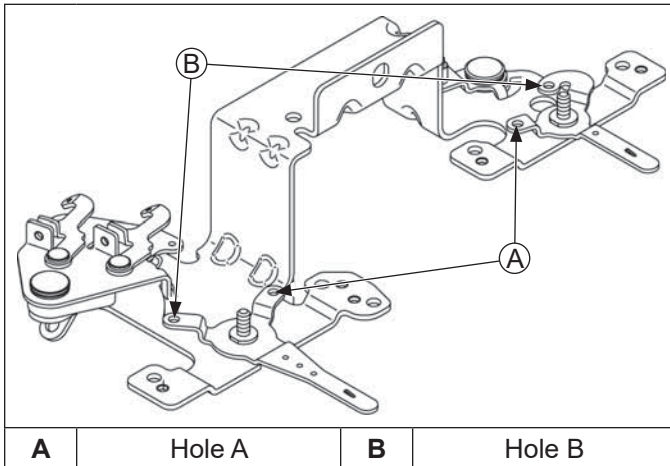

If individual throttle/choke lever control linkages were disconnected during disassembly, reconnect them based on operating direction of control cables to be used.

Hole A is used for Outer Pull control cable actuation.  
Hole B is used for Inner Pull control cable actuation.

1. Connect choke linkage to appropriate hole in choke lever and secure with small clip.
2. Connect throttle linkage to appropriate hole in throttle lever and secure with small clip.

### Adjusting Governor

1. Position governor lever so clamping area is inboard but completely on knurled area of governor cross shaft.
2. Move governor lever toward carburetor as far as it will go (wide-open throttle) and hold in position.
3. Insert a long thin rod or tool into hole on cross shaft and rotate shaft clockwise (viewed from end) as far as it will turn, then torque nut to 7.1 N·m (63 in. lb.).
4. Ensure correct color springs are used. Connect governor spring (with long looped end), to inner hole on governor lever and control bracket.

Connect governed idle spring to outer governor lever hole and control bracket. Long end of each spring must be toward governor lever. Make sure springs do not contact valley baffle.

### Governor Spring/RPM Chart

#### CH940-CH1000

Governor Idle Spring (Color)	High Speed (RPM)
Clear	1400-1625 RPM
Black	1626-1800 RPM

#### CH940, CH960, CH980

Governor Spring (Color)	High Speed (RPM)
Red	3000-3150 RPM
Green	3151-3300 RPM
Green Patch	3301-3675 RPM
Red Patch	3676-3900 RPM

#### CH1000

Governor Spring (Color)	High Speed (RPM)
Yellow Patch	3000-3150 RPM
Purple Patch	3151-3450 RPM
Purple	3451-3900 RPM

### Install Oil Sentry™ (if equipped)

1. Apply pipe sealant with Teflon® (Loctite® PST® 592™ Thread Sealant or equivalent) to Oil Sentry™ threads switch and install it into 1/8 in. port in closure plate. Torque switch to 10.7 N·m (95 in. lb.).
2. Connect green wire lead to Oil Sentry™ terminal.

### Install Blower Housing and Cylinder Shrouds

1. Align and install blower housing.
2. Secure blower housing with screws. Torque screws to 2.5 N·m (22 in. lb.) into new holes, or 2.0 N·m (18 in. lb.) into used holes.
3. Install cylinder shrouds and secure with shoulder screws. Torque screws to 2.5 N·m (22 in. lb.) into new holes, or 2.0 N·m (18 in. lb.) into used holes.

## Install Control Panel (if equipped)

### Control Panel Component

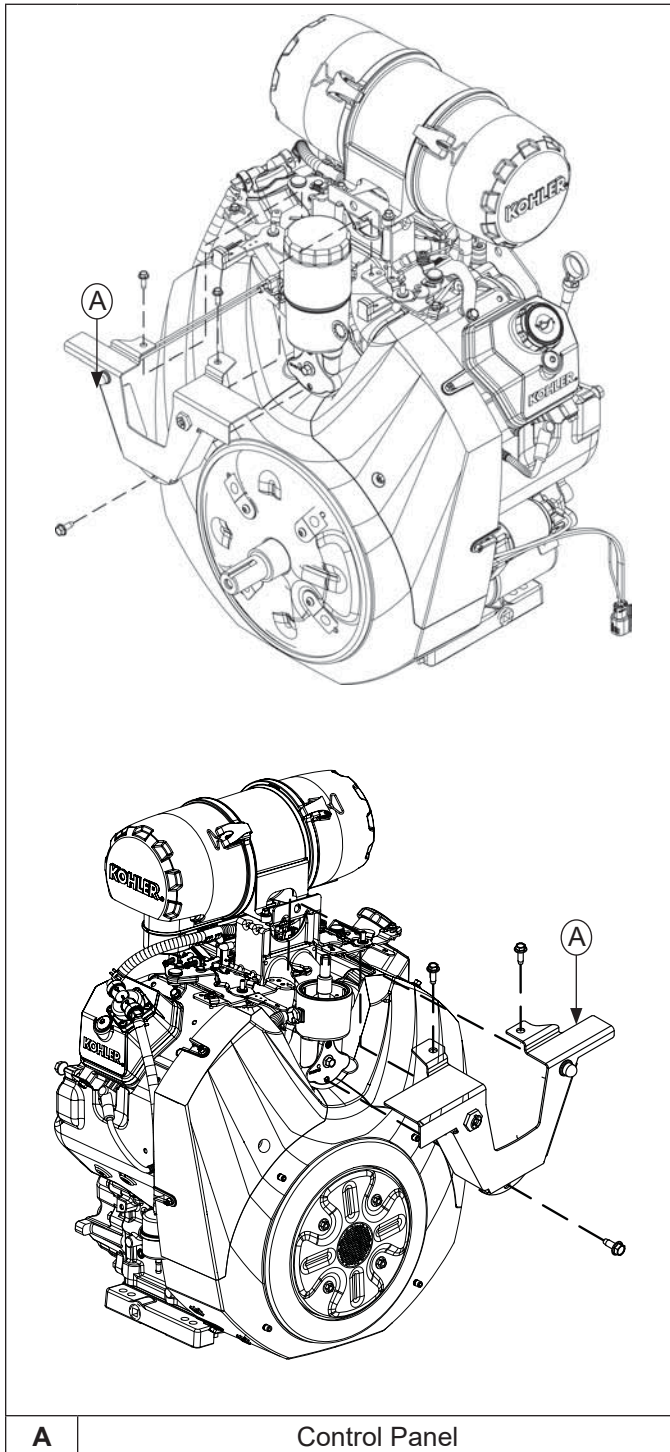

1. Install control panel to main control bracket and oil filter housing. Torque M6 screw into oil filter housing to 11.3 N·m (100 in. lb.) into a new hole, or 7.7 N·m (69 in. lb.) into a used hole. Torque M5 screws to 6.5 N·m (58 in. lb.) into new holes, or 4.1 N·m (37 in. lb.) into used holes.
2. Connect Oil Sentry™ indicator light wires.
3. Install knobs onto control levers.

## Install Muffler

1. Install new exhaust gaskets onto exhaust studs.
2. Install port liners (if equipped). Attach muffler and secure with nuts onto exhaust studs. Torque nuts to 24.4 N·m (216 in. lb.).
3. Install any attaching hardware and brackets. Torque M6 screws to 9.9 N·m (88 in. lb.), and M8 screws to 24.4 N·m (216 in. lb.).
4. Install spark arrestor (if used).

## Install Oil Filter and Add Oil to Crankcase

NOTE: Make sure both oil drain plugs are installed and torqued to 21.4 N·m (16 ft. lb.) to prevent oil leakage.

1. Install oil drain plugs. Torque plugs to 21.4 N·m (16 ft. lb.).
2. Place new filter in shallow pan with open end up. Fill with new oil until oil reaches bottom of threads. Allow 2 minutes for oil to be absorbed by filter material.
3. Apply a thin film of clean oil to rubber gasket on new filter.
4. Refer to instructions on oil filter for proper installation.
5. Fill crankcase with new oil. Level should be at top of indicator on dipstick.
6. Reinstall oil fill cap/plug and dipstick and tighten securely.

## Connect Spark Plug Leads

Connect leads to spark plugs.

## Prepare Engine for Operation

Engine is now completely reassembled. Before starting or operating engine, follow proceeding steps.

1. Make sure all hardware is tightened securely.
2. Make sure oil drain plugs, Oil Sentry™ pressure switch, and a new oil filter are installed.
3. Adjust carburetor, idle fuel needles, or idle speed adjusting screw as necessary.

## Testing Engine

It is recommended engine be operated on a test stand or bench prior to installation in equipment.

1. Set engine up on a test stand. Install an oil pressure gauge. Start engine and check to be certain oil pressure (20 psi or more) is present. Run engine at idle for 2-3 minutes, then 5-6 minutes more between idle and midrange. Adjust carburetor mixture settings as necessary (as available).
2. Adjust governed idle and high speed (RPM) to required settings. Make sure maximum engine speed does not exceed 3900 RPM (no load).



1P62 690 01



6 50531 99106 5