

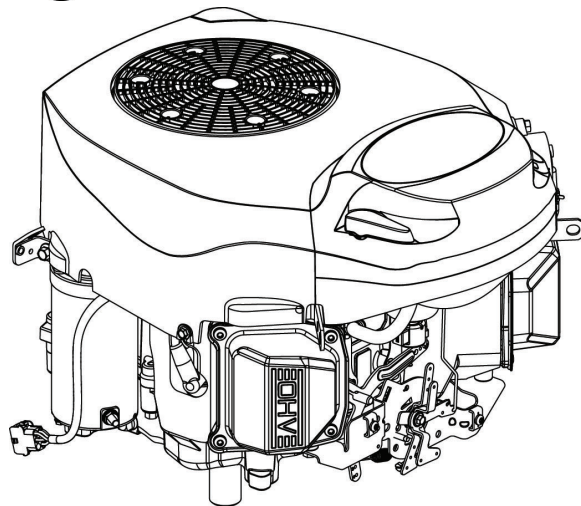

Command

KT610-KT620, KT715-KT745,
KT720-KT726

Service Manual

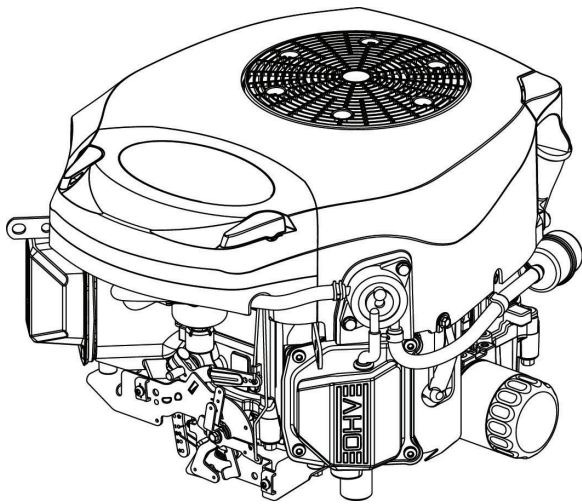

Kohler Engines
is now Rehlko.



2	Safety
3	Maintenance
5	Specifications
22	Tools and Aids
25	Troubleshooting
30	Air Cleaner/Intake
32	Fuel System
51	Governor System
52	Lubrication System
54	Electrical System
62	Starter System
66	Emission Compliant Systems
69	Disassembly/Inspection and Service
82	Reassembly

IMPORTANT: Read all safety precautions and instructions carefully before operating equipment. Refer to operating instruction of equipment that this engine powers.

Ensure engine is stopped and level before performing any maintenance or service.

Safety

SAFETY PRECAUTIONS

⚠ WARNING: A hazard that could result in death, serious injury, or substantial property damage.

⚠ CAUTION: A hazard that could result in minor personal injury or property damage.

NOTE: is used to notify people of important installation, operation, or maintenance information.

	⚠ WARNING
	Explosive Fuel can cause fires and severe burns. Do not fill fuel tank while engine is hot or running.
Gasoline is extremely flammable and its vapors can explode if ignited. Store gasoline only in approved containers, in well ventilated, unoccupied buildings, away from sparks or flames. Spilled fuel could ignite if it comes in contact with hot parts or sparks from ignition. Never use gasoline as a cleaning agent.	

	⚠ WARNING
	Rotating Parts can cause severe injury. Stay away while engine is in operation.
Keep hands, feet, hair, and clothing away from all moving parts to prevent injury. Never operate engine with covers, shrouds, or guards removed.	

	⚠ WARNING
	Carbon Monoxide can cause severe nausea, fainting or death. Avoid inhaling exhaust fumes. Never run engine indoors or in enclosed spaces.
Engine exhaust gases contain poisonous carbon monoxide. Carbon monoxide is odorless, colorless, and can cause death if inhaled.	

	⚠ WARNING
	Accidental Starts can cause severe injury or death. Disconnect and ground spark plug lead(s) before servicing.
Before working on engine or equipment, disable engine as follows: 1) Disconnect spark plug lead(s). 2) Disconnect negative (-) battery cable from battery.	





	⚠ WARNING
	Hot Parts can cause severe burns. Do not touch engine while operating or just after stopping.
Never operate engine with heat shields or guards removed.	

	⚠ WARNING
	Cleaning Solvents can cause severe injury or death. Use only in well ventilated areas away from ignition sources.
Carburetor cleaners and solvents are extremely flammable. Follow cleaner manufacturer's warnings and instructions on its proper and safe use. Never use gasoline as a cleaning agent.	

	⚠ CAUTION
	Electrical Shock can cause injury. Do not touch wires while engine is running.

	⚠ CAUTION
	Damaging Crankshaft and Flywheel can cause personal injury.
Using improper procedures can lead to broken fragments. Broken fragments could be thrown from engine. Always observe and use precautions and procedures when installing flywheel.	

MAINTENANCE INSTRUCTIONS

  	 WARNING	Before working on engine or equipment, disable engine as follows: 1) Disconnect spark plug lead(s). 2) Disconnect negative (-) battery cable from battery.
	Accidental Starts can cause severe injury or death. Disconnect and ground spark plug lead(s) before servicing.	

Normal maintenance, replacement or repair of emission control devices and systems may be performed by any repair establishment or individual; however, warranty repairs must be performed by a Rehlko authorized dealer.

MAINTENANCE SCHEDULE

Every 25 Hours¹

• Service/replace precleaner.	Air Cleaner/Intake
• Replace LPAC element (if not equipped with precleaner).	Air Cleaner/Intake

Every 50 Hours¹

• Replace LPAC element (if equipped with precleaner).	Air Cleaner/Intake
• Replace high performance air cleaner element (if not equipped with precleaner).	Air Cleaner/Intake

Every 75 Hours¹

• Replace high performance air cleaner element (if equipped with precleaner).	Air Cleaner/Intake
• Replace PRO performance air cleaner element (if not equipped with precleaner).	Air Cleaner/Intake

Every 100 Hours¹

• Replace PRO performance air cleaner element (if equipped with precleaner).	Air Cleaner/Intake
• Change oil and filter.	Lubrication System
• Remove cooling shrouds and clean cooling areas.	Air Cleaner/Intake

Every 100 Hours

• Check that all fasteners are in place and components are properly secured.	Reassembly
• Replace fuel filter.	

Every 300 Hours³

• Change oil and filter (Xtended Life PRO 10W-50 oil and Xtended Life PRO filter only.)	Lubrication System
---	--------------------

Every 500 Hours²

• Have valve lash checked/adjusted.	Reassembly
-------------------------------------	------------

Every 500 Hours

• Replace spark plugs and set gap.	Electrical System
------------------------------------	-------------------

¹ Perform these procedures more frequently under severe, dusty, dirty conditions.

² Have a Rehlko authorized dealer perform this service.

³ Option only if using Xtended Life PRO oil and Xtended Life PRO filter.

REPAIRS/SERVICE PARTS

Rehlko genuine service parts can be purchased from Rehlko authorized dealers. To find a local Rehlko authorized dealer visit Engines.rehlko.com or call 1-800-544-2444 (U.S. and Canada).

Maintenance

OIL RECOMMENDATIONS

All-season Xtended Life PRO 10W-50 Synthetic Oil is the ideal oil for Rehlko engines. It is specifically formulated to extend the oil and oil filter change interval to 300 Hours when paired with a Xtended Life PRO Oil Filter.

300-Hour oil and oil filter change intervals are exclusive to and only authorized on Rehlko engines that utilize both the Xtended Life PRO 10W-50 Synthetic Oil and Xtended Life PRO Extended Life Oil Filter. Alternative engine oils and oil filters may be used with Rehlko engines but require 100-Hour oil and oil filter change intervals for proper maintenance. Oil must be API

(American Petroleum Institute) service class SJ or higher. Select viscosity based on air temperature at time of operation as shown below.

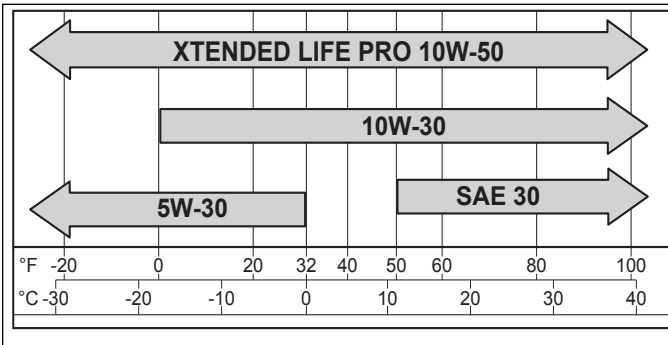

FUEL RECOMMENDATIONS

	WARNING
	Explosive Fuel can cause fires and severe burns. Do not fill fuel tank while engine is hot or running.
Gasoline is extremely flammable and its vapors can explode if ignited. Store gasoline only in approved containers, in well ventilated, unoccupied buildings, away from sparks or flames. Spilled fuel could ignite if it comes in contact with hot parts or sparks from ignition. Never use gasoline as a cleaning agent.	

NOTE: E15, E20 and E85 are NOT approved and should NOT be used; effects of old, stale or contaminated fuel are not warrantable.

Fuel must meet these requirements:

- Clean, fresh, unleaded gasoline.
- Octane rating of 87 (R+M)/2 or higher.
- Research Octane Number (RON) 90 octane minimum.
- Gasoline up to 10% ethyl alcohol, 90% unleaded is acceptable.
- Methyl Tertiary Butyl Ether (MTBE) and unleaded gasoline blend (max 15% MTBE by volume) are approved.
- Do not add oil to gasoline.
- Do not overfill fuel tank.
- Do not use gasoline older than 30 days.

STORAGE

If engine will be out of service for 2 months or more follow procedure below.

1. Add Xtended Life PRO Series fuel treatment or equivalent to fuel tank. Run engine 2-3 minutes to get stabilized fuel into fuel system (failures due to untreated fuel are not warrantable).
2. Change oil while engine is still warm from operation. (NOT required if using Xtended Life PRO 10W-50 full-synthetic oil). Remove spark plug(s) and pour about 1 oz. of engine oil into cylinder(s). Replace spark plug(s) and crank engine slowly to distribute oil.
3. Disconnect negative (-) battery cable.
4. Store engine in a clean, dry place.

Engine Dimensions with Low Profile or High Performance Air Cleaner-Flywheel Side

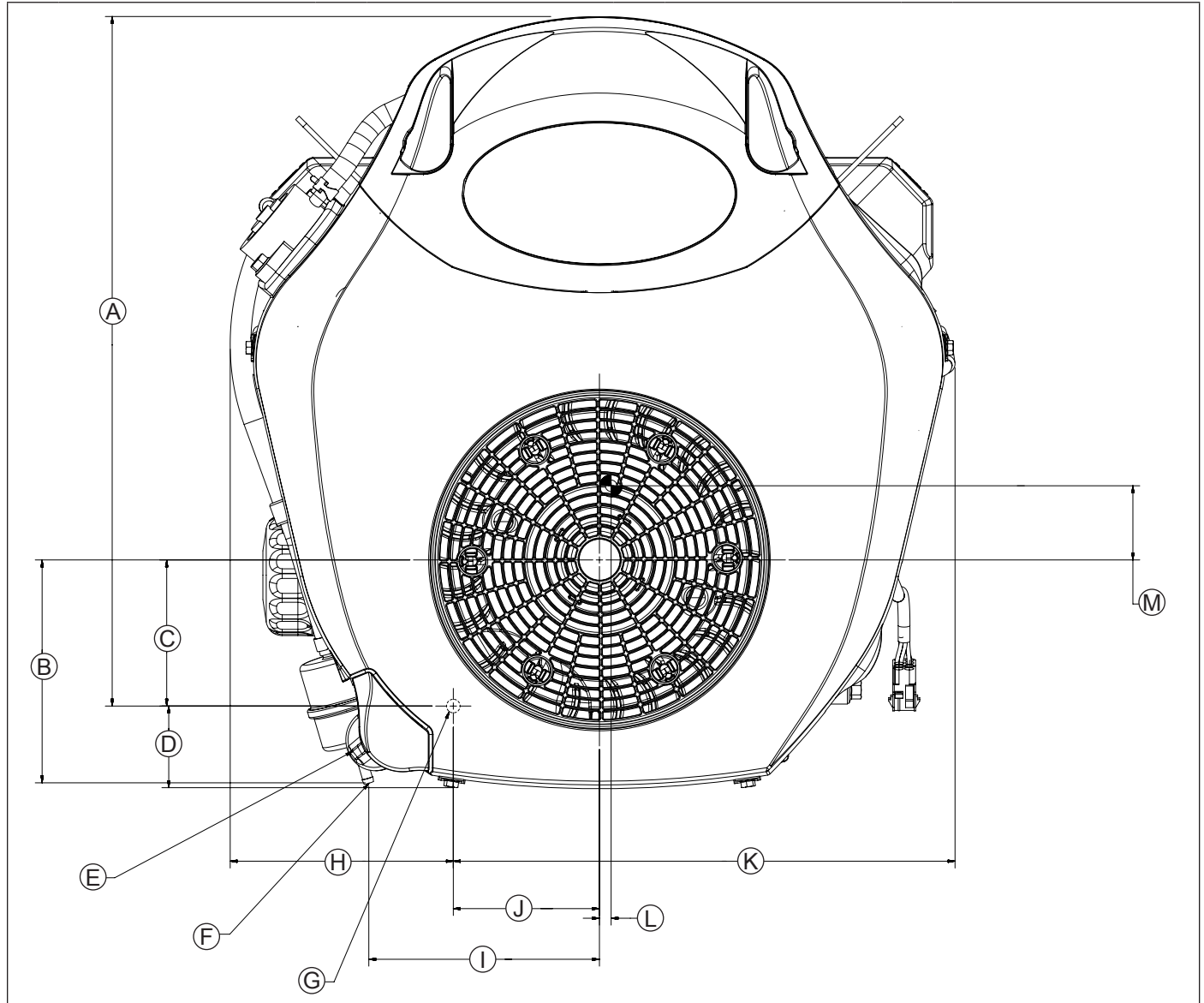

A	423.0 mm (16.65 in.)	B	136.7 mm (5.38 in.)	C	89.6 mm (3.53 in.)	D	50.1 mm (1.97 in.)
E	Oil Fill and Dipstick (Yellow)	F	Fuel Line Connection Point	G	Mounting Hole "A"	H	136.9 mm (5.39 in.)
I	141.5 mm (5.57 in.)	J	89.7 mm (3.53 in.)	K	307.9 mm (12.12 in.)	L	7.2 mm (0.28) Center of Gravity
M	45.5 mm (1.79 in.) Center of Gravity						

Specifications

Engine Dimensions with Low Profile or High Performance Air Cleaner-Oil Filter Side

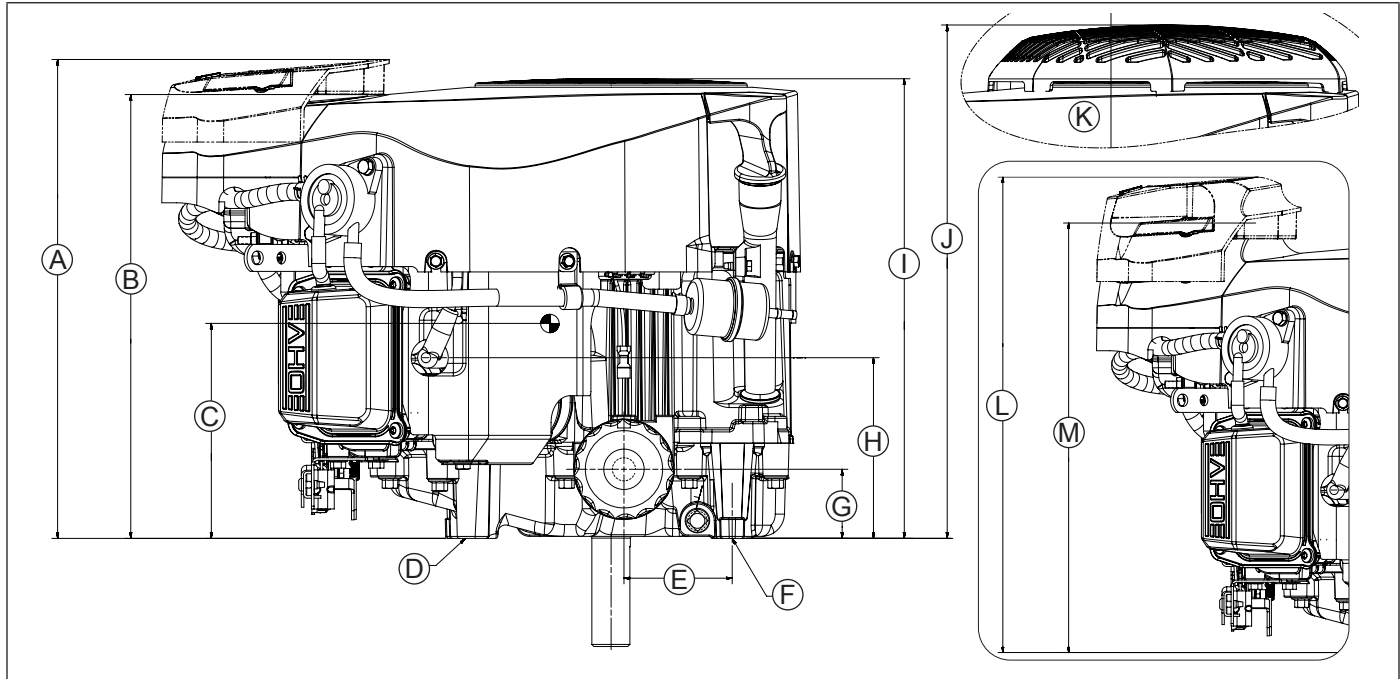

A	355.1 mm (13.98 in.) Low Profile Air Cleaner Removal	B	329.1 mm (12.96 in.) Top of Low Profile Air Cleaner	C	159.4 mm (6.28 in.) Center of Gravity	D	Engine Mounting Surface
E	80.3 mm (3.16 in.) Oil Filter	F	Mounting Hole "A"	G	51.2 mm (2.02 in.) Oil Filter	H	134.0 mm (5.28 in.) Spark Plug Center Line
I	340.9 mm (13.42 in.)	J	380.7 mm (14.99 in.)	K	Optional Fixed Guard	L	392.1 mm (15.44 in.) High Performance Air Cleaner Removal
M	354.2 mm (13.94 in.) Top of High Performance Air Cleaner						

Engine Dimensions with Low Profile or High Performance Air Cleaner-Engine Mounting Surface (PTO End)

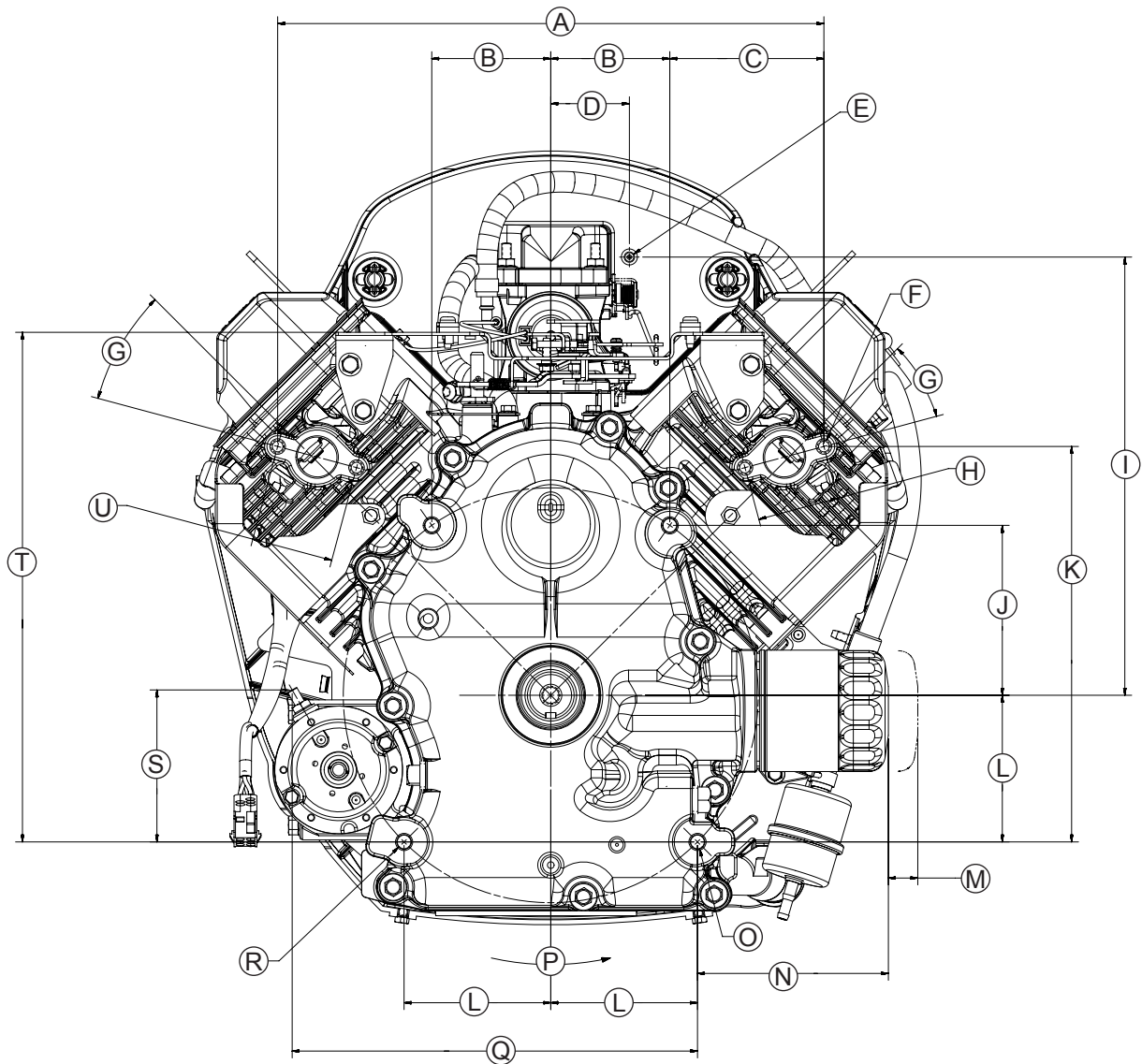

A	334.3 mm (13.16 in.)	B	72.8 mm (2.87 in.)	C	94.3 mm (3.71 in.)	D	48.1 mm (1.89 in.)
E	Evap Connection Point	F	4 X 5/16-18 UNC-2B in. 16.5 mm (0.649 in.) Deep No Studs	G	30°	H	50.0 mm (1.97 in.) Exhaust Port #2
I	268.3 mm (10.56 in.)	J	104.0 mm (4.10 in.)	K	242.1 mm (9.53 in.)	L	89.8 mm (3.54 in.)
M	18.0 mm (0.71 in.) Oil Filter Removal	N	116.8 mm (4.60 in.)	O	Mounting Hole "A"	P	Rotation Direction
Q	248.1 mm (9.77 in.) Starter Stud	R	4 X 9.005 mm (0.355 in.) 37.0 mm (1.46 in.) Deep on a Ø 254.0 mm (10.0 in.) B.C.	S	93.1 mm (3.66 in.) Starter Stud	T	312.0 mm (12.28 in.) Throttle and Choke Cable Mounting Surface
U	50.0 mm (1.97 in.) Exhaust Port #1						

Specifications

Engine Dimensions with Low Profile or High Performance Air Cleaner-Starter Side

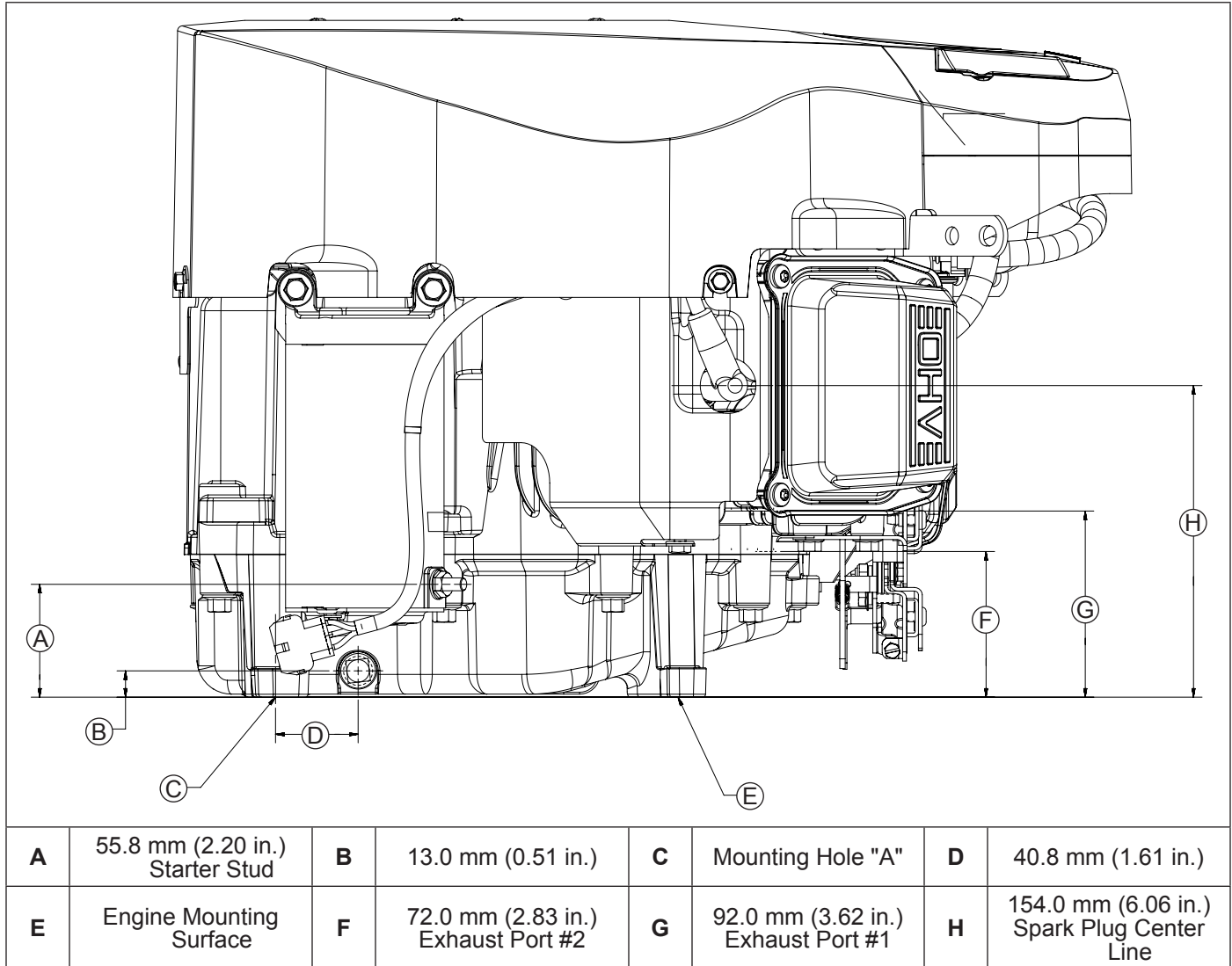

Engine Dimensions with Low Profile or High Performance Air Cleaner-Valve Cover Side

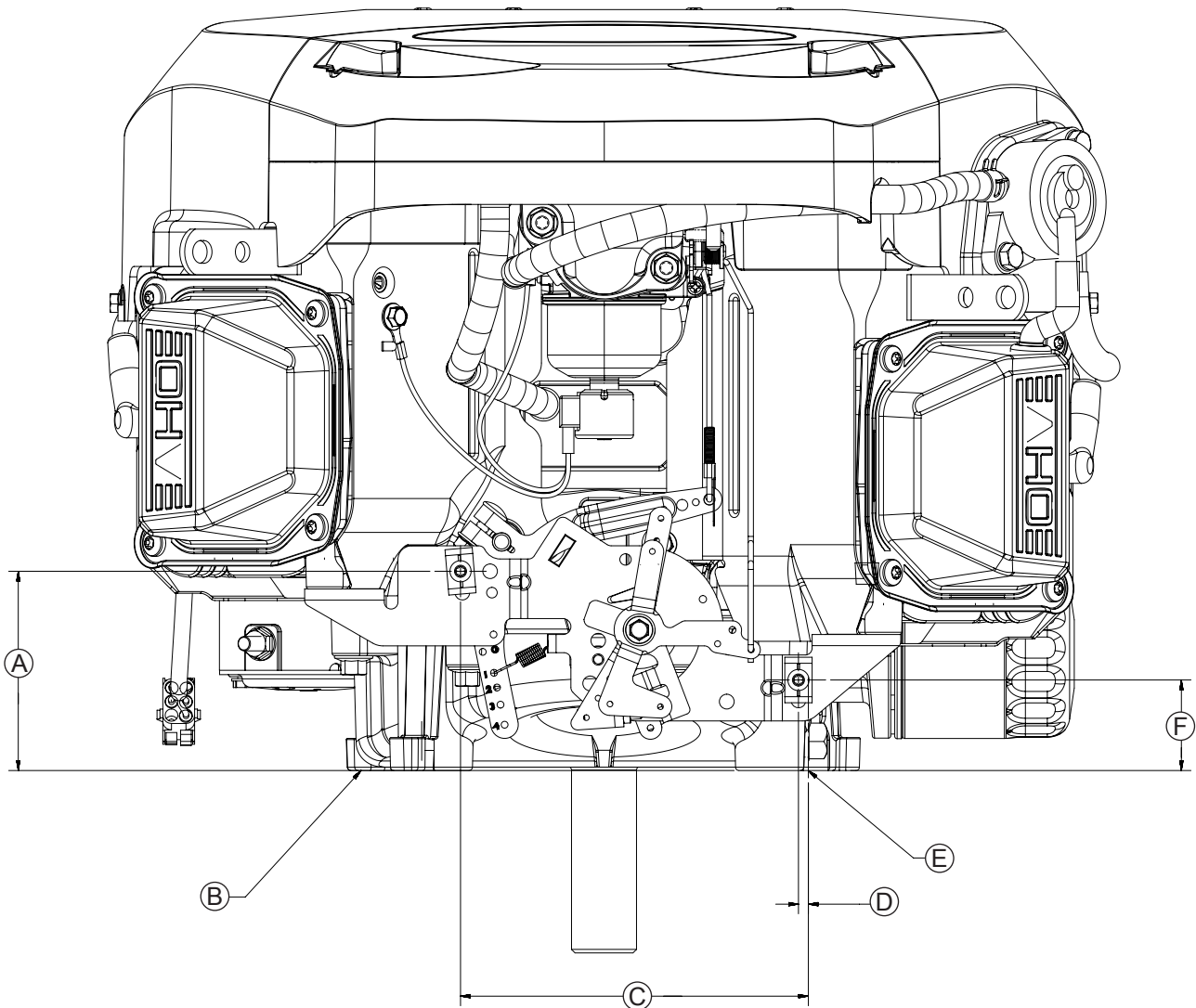

A	87.6 mm (3.45 in.)	B	Engine Mounting Surface	C	152.9 mm (6.02 in.)	D	4.4 mm (0.17 in.)
E	Mounting Hole "A"	F	39.8 mm (1.57 in.)				

Specifications

Engine Dimensions with PRO Performance Air Cleaner-Flywheel Side

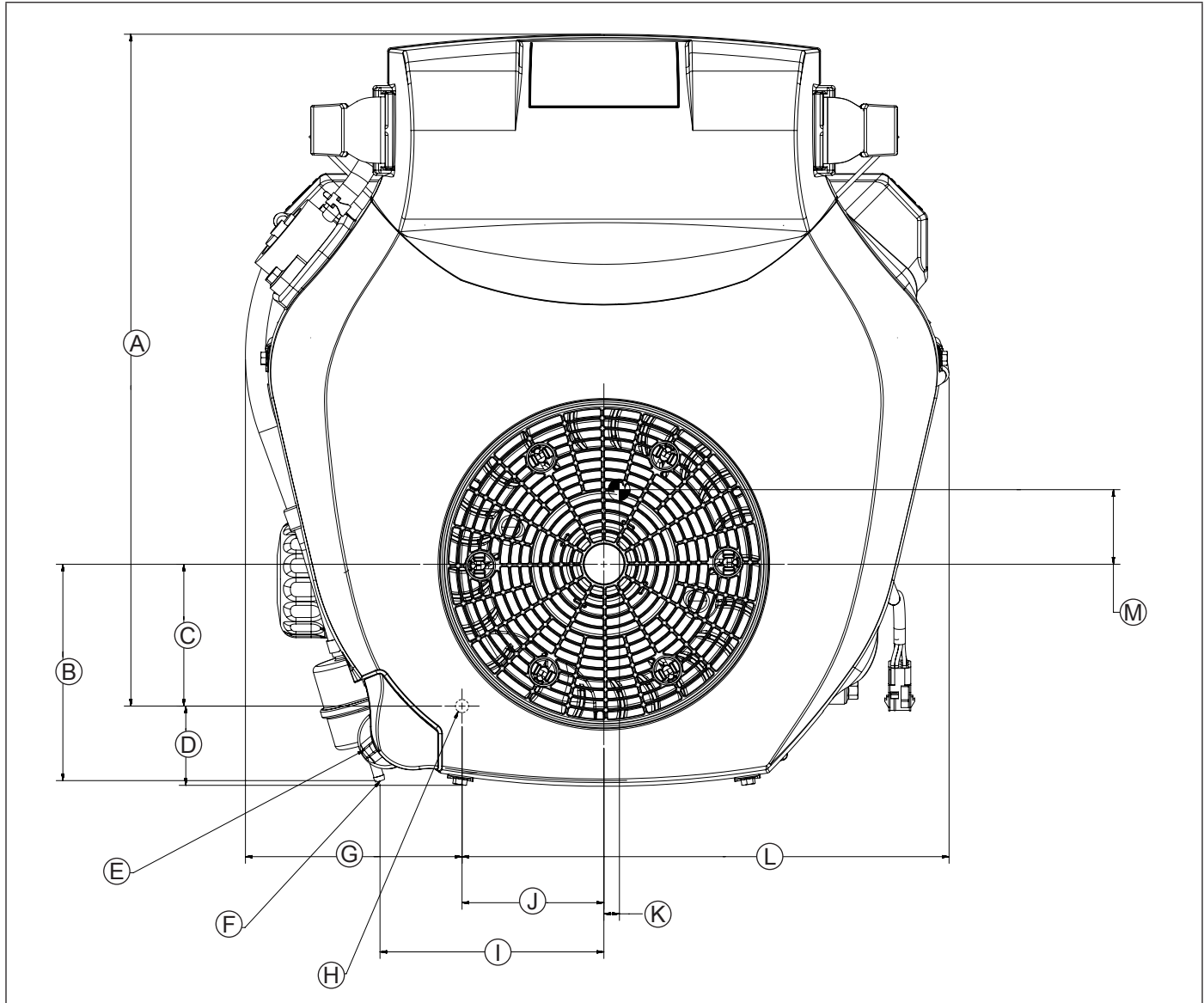

A	424.7 mm (16.72 in.)	B	136.7 mm (5.38 in.)	C	89.6 mm (3.53 in.)	D	50.1 mm (1.97 in.)
E	Oil Fill and Dipstick (Yellow)	F	Fuel Line Connection Point	G	136.9 mm (5.39 in.)	H	Mounting Hole "A"
I	141.5 mm (5.57 in.)	J	89.7 mm (3.53 in.)	K	9.7 mm (0.38 in.) Center of Gravity	L	307.9 mm (12.12 in.)
M	47.0 mm (1.85 in.) Center of Gravity						

Engine Dimensions with PRO Performance Air Cleaner-Oil Filter Side

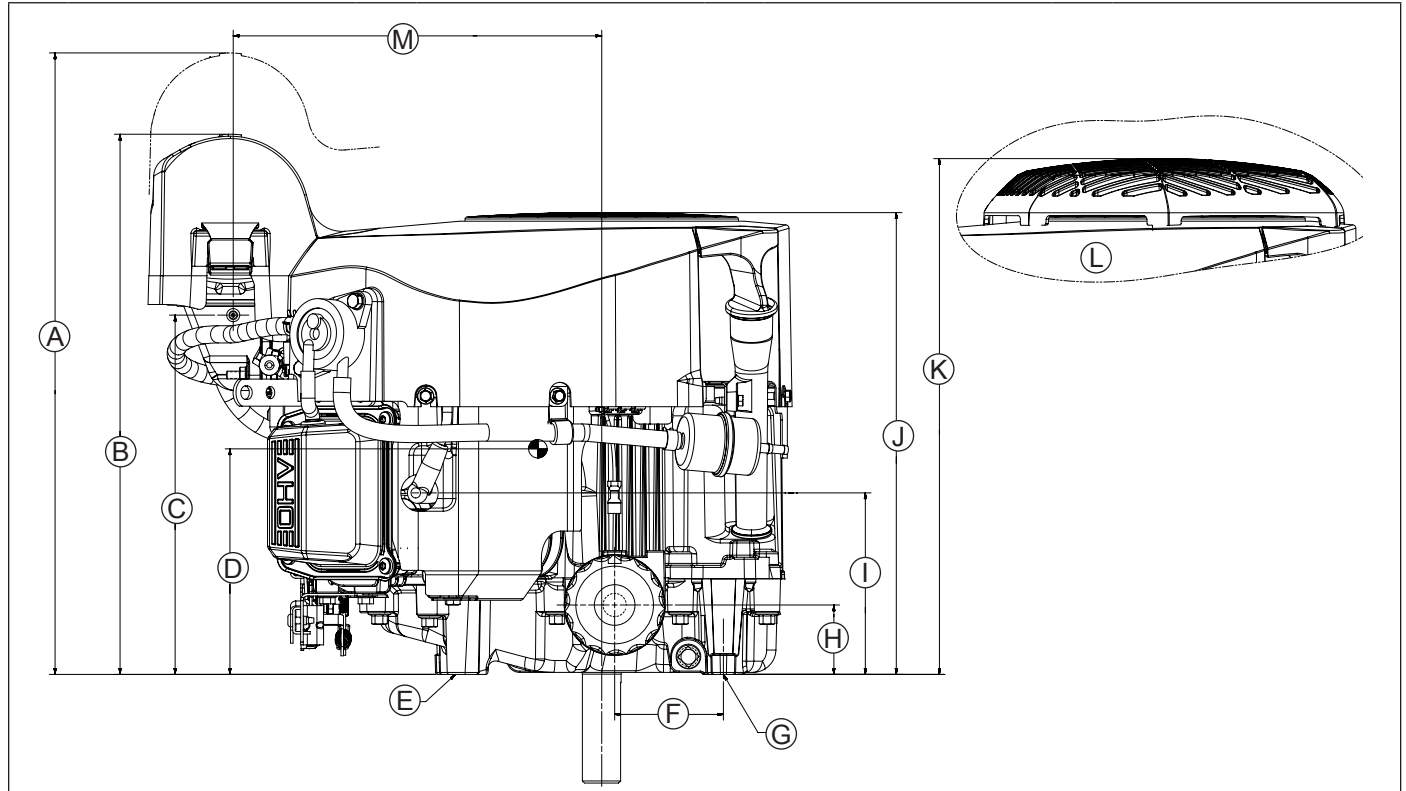

A	458.7 mm (18.06 in.) Air Cleaner Removal	B	398.7 mm (15.70 in.) Top of Air Cleaner	C	265.2 mm (10.44 in.) Evap Connection Point	D	166.5 mm (6.56 in.) Center of Gravity
E	Engine Mounting Surface	F	80.3 mm (3.16 in.) Oil Filter	G	Mounting Hole "A"	H	51.2 mm (2.02 in.) Oil Filter
I	134.0 mm (5.28 in.) Spark Plug Center Line	J	340.9 mm (13.42 in.)	K	380.7 mm (14.99 in.)	L	Optional Fixed Guard
M	272.0 mm (10.71 in.) Evap Connection Point						

Specifications

Engine Dimensions with PRO Performance Air Cleaner-Engine Mounting Surface (PTO End)

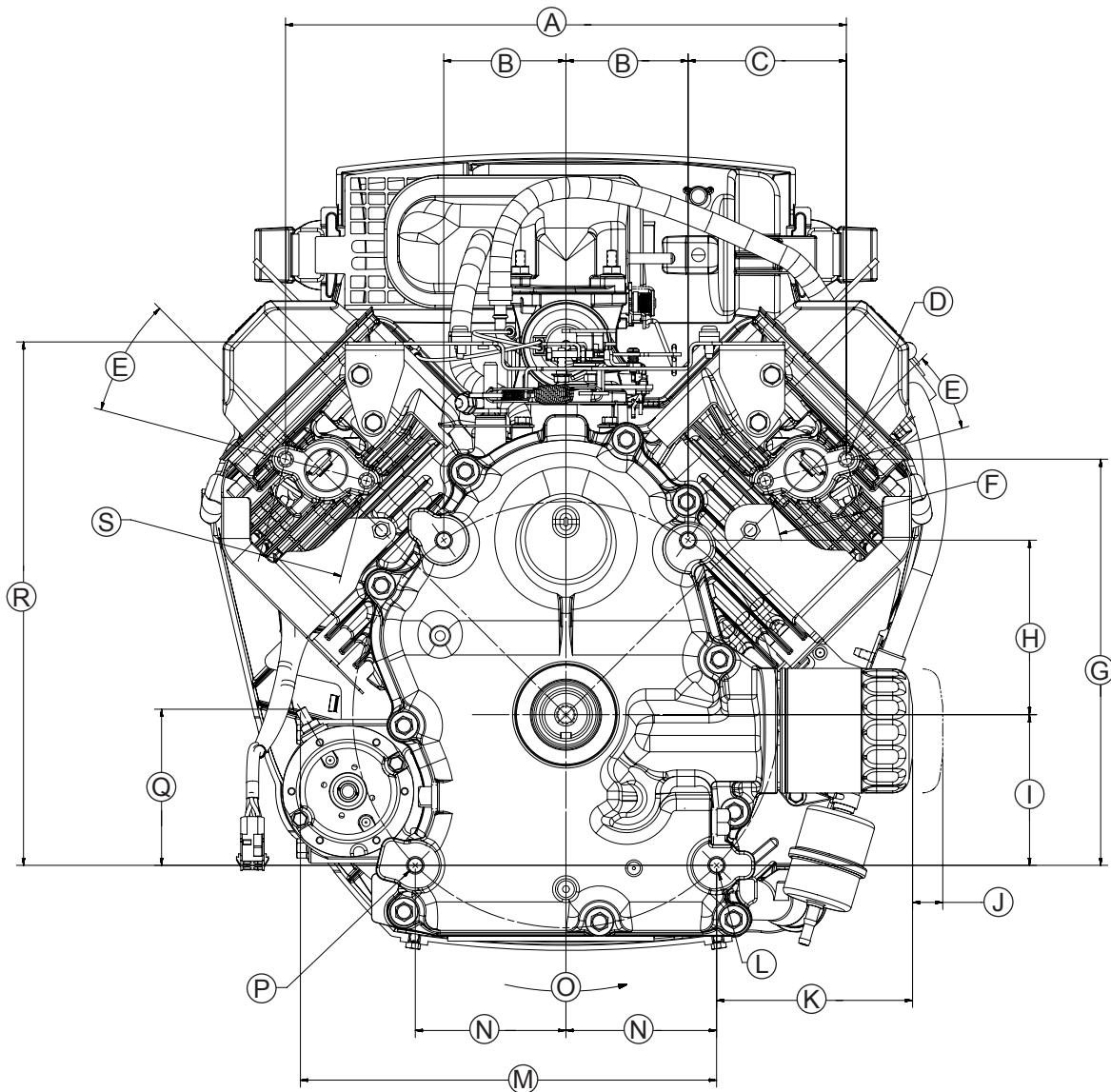

A	334.3 mm (13.16 in.)	B	72.8 mm (2.87 in.)	C	94.3 mm (3.71 in.)	D	4 X 5/16-18 UNC-2B in. 16.5 mm (0.649 in.) Deep No Studs
E	30°	F	50.0 mm (1.97 in.) Exhaust Port #2	G	242.1 mm (9.53 in.)	H	104.0 mm (4.10 in.)
I	89.8 mm (3.54 in.)	J	18.0 mm (0.71 in.) Oil Filter Removal	K	116.8 mm (4.60 in.)	L	Mounting Hole "A"
M	248.1 mm (9.77 in.) Starter Stud	N	89.8 mm (3.54 in.)	O	Rotation Direction	P	4 X 9.005 mm (0.355 in.) 37 mm (1.46 in.) Deep on a Ø 254 mm (10.0 in.) B.C.
Q	93.1 mm (3.66 in.) Starter Stud	R	312.0 mm (12.28 in.) Throttle and Choke Cable Mounting Surface	S	50.0 mm (1.97 in.) Exhaust Port #1		

Engine Dimensions with PRO Performance Air Cleaner-Starter Side

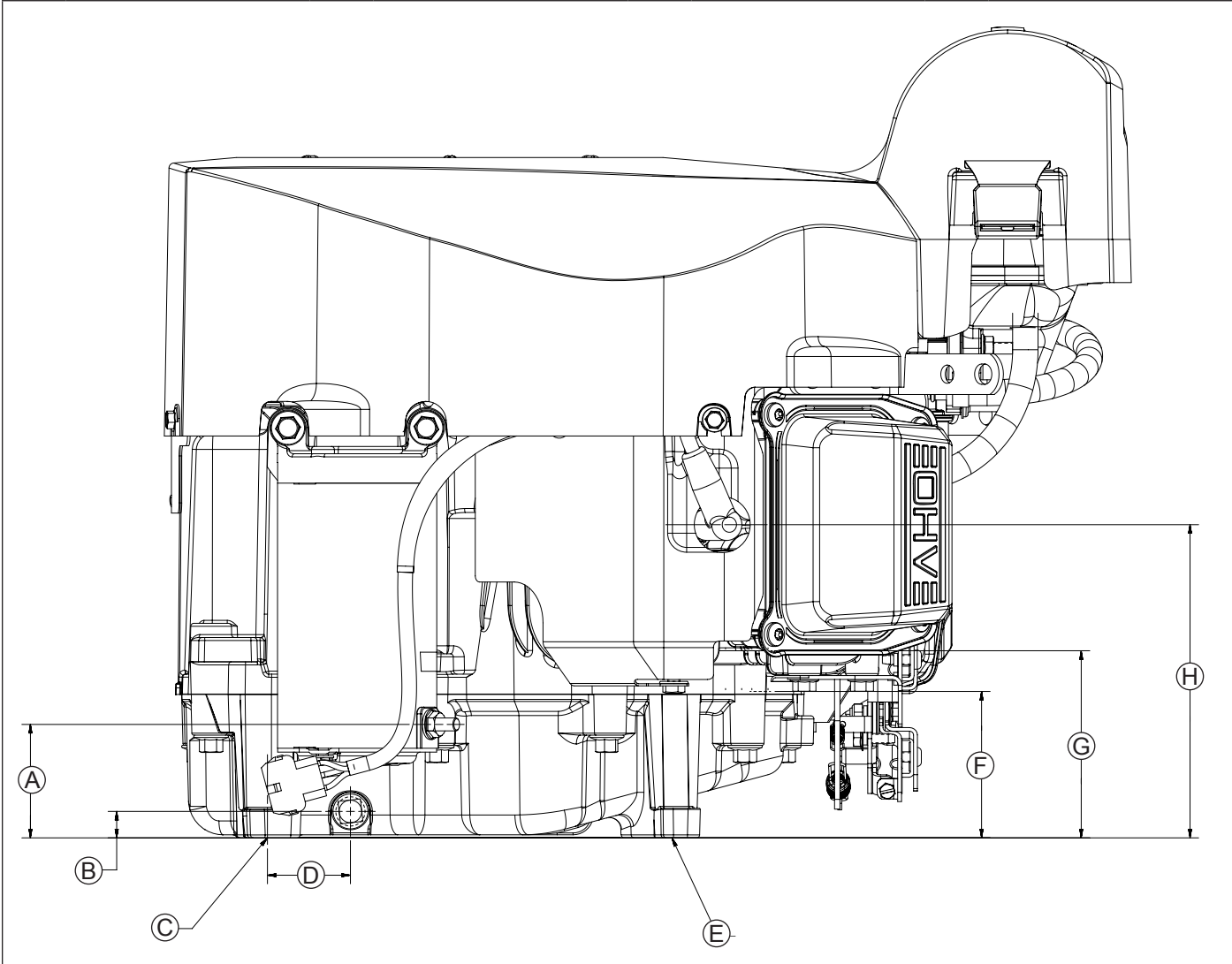

A	55.8 mm (2.20 in.) Starter Stud	B	13.0 mm (0.51 in.)	C	Mounting Hole "A"	D	40.8 mm (1.61 in.)
E	Engine Mounting Surface	F	72.0 mm (2.83 in.) Exhaust Port #2	G	92.0 mm (3.62 in.) Exhaust Port #1	H	154.0 mm (6.06 in.) Spark Plug Center Line

Specifications

Engine Dimensions with PRO Performance Air Cleaner-Valve Cover Side

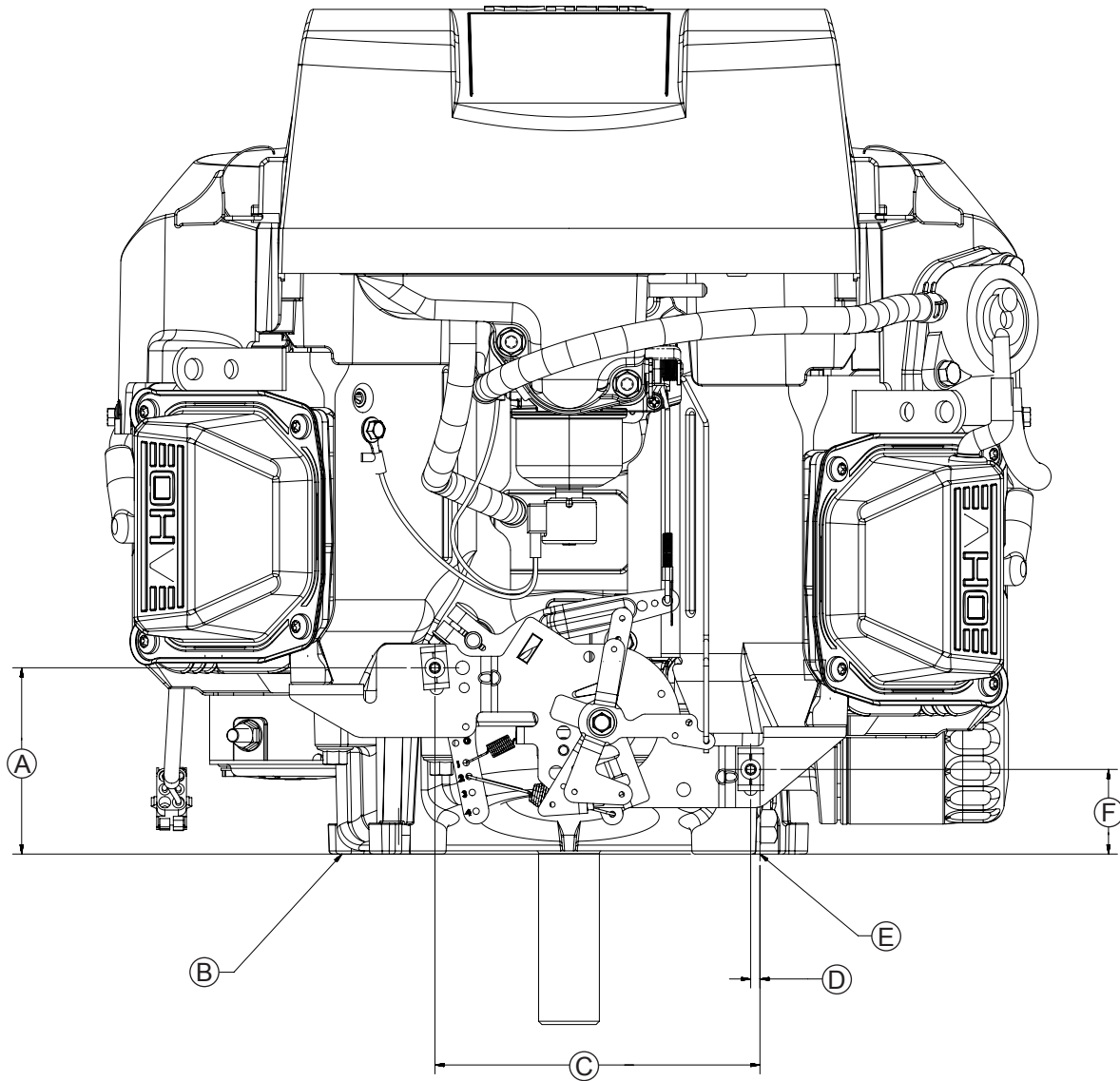

A	87.6 mm (3.45 in.)	B	Engine Mounting Surface	C	152.9 mm (6.02 in.)	D	4.4 mm (0.17 in.)
E	Mounting Hole "A"	F	39.8 mm (1.57 in.)				

ENGINE IDENTIFICATION NUMBERS

Rehiko engine identification numbers (model, specification and serial) should be referenced for efficient repair, ordering correct parts, and engine replacement.

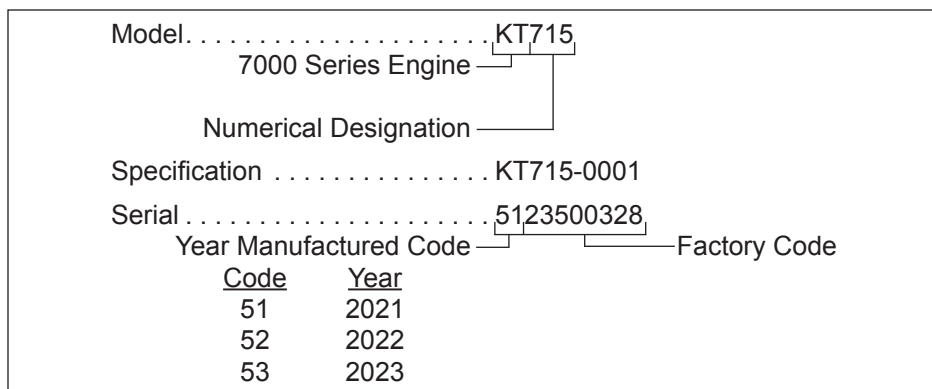

GENERAL SPECIFICATIONS ^{3,6}	KT600		KT715	KT730	KT720		KT724
	KT610	KT620	KT725	KT735	KT740*	KT722	KT726
Bore	83 mm (3.27 in.)						
Stroke	61 mm (2.4 in.)	67 mm (2.64 in.)			69 mm (2.72 in.)		
Displacement	660 cc (40.3 cu. in.)	725 cc (44 cu. in.)			747 cc (46 cu. in.)		
Oil Capacity (refill)	1.9 l (2.0 qt.)						
Maximum Angle of Operation (@ full oil level) ⁴	25°						

*KT740 engines with PRO Performance Air Cleaner have 747 cc (46 cu. in.) Displacement.

TORQUE SPECIFICATIONS ^{3,5}	KT600		KT715	KT730	KT720		KT724
	KT610	KT620	KT725	KT735	KT740	KT722	KT726
Auto Choke							
eChoke™ Stepper Motor to Bracket Fastener Air Cleaner Base to Mounting Studs	3.1 N·m (27.4 in. lb.) 6.2-7.3 N·m (55-65 in. lb.)						
Smart-Choke™ Air Vane Deflector to Intake Manifold Air Cleaner Base to Mounting Studs Bracket Assembly Screw	1 N·m (9 in. lb.) 6.2-7.3 N·m (55-65 in. lb.) 5 N·m (45 in. lb.)						
Baffle and Sheet Metal into Aluminum							
M5 Thread Forming Fasteners	8.5 N·m (75 in. lb.) into new hole 4.0 N·m (35 in. lb.) into used hole						
M6 Thread Forming Fasteners	10.7 N·m (95 in. lb.) into new hole 7.3 N·m (65 in. lb.) into used hole						

³ Values are in Metric units. Values in parentheses are English equivalents.

⁴ Exceeding maximum angle of operation may cause engine damage from insufficient lubrication.

⁵ Lubricate threads with engine oil prior to assembly.

⁶ Any and all horsepower (hp) references by Rehiko are Certified Power Ratings and per SAE J1940 & J1995 hp standards. Details on Certified Power Ratings can be found at Engines.rehiko.com.

Specifications

TORQUE SPECIFICATIONS^{3,5}	KT600						
	KT610	KT715	KT730		KT720	KT724	
	KT620	KT725	KT735	KT740	KT722	KT726	KT745

Blower Housing and Sheet Metal

M3 HI-LO Screw	2.3 N·m (20 in. lb.)
M4 HI-LO Screw	2.8 N·m (25 in. lb.)
M5 Fasteners	6.2 N·m (55 in. lb.) into new hole 4.0 N·m (35 in. lb.) into used hole
M6 Fasteners	10.7 N·m (95 in. lb.) into new hole 7.3 N·m (65 in. lb.) into used hole

Carburetor

Mounting Nut	6.2-7.3 N·m (55-65 in. lb.)
--------------	-----------------------------

Connecting Rod

Cap Fastener (torque in increments)	
Black Coating	11.3 N·m (100 in. lb.)
Gray Metallic Coating	13.6 N·m (120 in. lb.)

Crankcase

Breather Assembly Outer Cover Stud	6.2 N·m (55 in. lb.) into new hole 4.0 N·m (35 in. lb.) into used hole
Outer Cover Hex Nut	1.3 N·m (11.5 in. lb.)
Oil Drain Plug	13.6 N·m (10 ft. lb.)

Cylinder Head

Head Bolt Fastener (torque in 2 increments)	first to 22.6 N·m (200 in. lb.) finally to 41.8 N·m (370 in. lb.)
Rocker Arm Stud	11.3 N·m (100 in. lb.)

Flywheel

Retaining Screw	74.5 N·m (55 ft. lb.)
-----------------	-----------------------

Fuel Pump

Screw	2.8 N·m (25 in. lb.)
-------	----------------------

Governor

Lever Nut	6.8 N·m (60 in. lb.)
-----------	----------------------

Ignition

Spark Plug	27 N·m (20 ft. lb.)
Module Fastener	4.0-6.2 N·m (35-55 in. lb.)
Rectifier-Regulator Fastener	4.0 N·m (35 in. lb.)

Intake Manifold

Mounting Fastener (torque in 2 increments)	first to 7.4 N·m (66 in. lb.) finally to 9.9 N·m (88 in. lb.)
--	--

Muffler

M8 Hex Nuts	24.4 N·m (216 in. lb.)
M8 Lock Nuts	27.8 N·m (246 in. lb.)
5/16-18 Capscrew	16.9 N·m (150 in. lb.)
Bracket Screw	9.9 N·m (88 in. lb.)

³ Values are in Metric units. Values in parentheses are English equivalents.

⁵ Lubricate threads with engine oil prior to assembly.

Specifications

TORQUE SPECIFICATIONS ^{3,5}	KT600	KT715	KT730	KT720	KT724
	KT610	KT725	KT735	KT740	KT722
	KT620	KT726	KT745		

Oil Pan	
Fastener	24.4 N·m (216 in. lb.)

Oil Pump	
Screw (no torque sequence)	9.9 N·m (88 in. lb.)

Oil Sentry™	
Pressure Switch	4.5 N·m (40 in. lb.)

Solenoid (Starter)	
Mounting Hardware	4.0-6.0 N·m (35-53 in. lb.)
Nut, Positive (+) Brush Lead	8.0-11.0 N·m (71-97 in. lb.)

Speed Control Bracket	
Fastener	10.7 N·m (95 in. lb.) into new holes 7.3 N·m (65 in. lb.) into used holes

Starter Assembly	
Thru Bolt Inertia Drive Solenoid Shift	4.5-5.7 N·m (40-50 in. lb.) 5.6-9.0 N·m (49-79 in. lb.)
Mounting Screw	23.8 N·m (211 in. lb.)
Brush Holder Mounting Screw	2.5-3.3 N·m (22-29 in. lb.)

Stator	
Mounting Screw	8.8 N·m (78 in. lb.)

Valve Cover	
Stamped Steel Cover Fastener	13.6 N·m (120 in. lb.)
Plastic Cover Fastener Hex Flange Pan Head	9.0 N·m (80 in. lb.) 6.2 N·m (55 in. lb.)

CLEARANCE SPECIFICATIONS ³	KT600	KT715	KT730	KT720	KT724
	KT610	KT725	KT735	KT740	KT722
	KT620	KT726	KT745		

Camshaft	
End Play	0.06/0.40 mm (0.0024/0.0157 in.)
Running Clearance	0.040/0.077 mm (0.0016/0.0030 in.)
Bore I.D. New Max. Wear Limit	20.000/20.025 mm (0.7874/0.7884 in.) 20.038 mm (0.7889 in.)
Bearing Surface O.D. New Max. Wear Limit	19.948/19.960 mm (0.7854/0.7858 in.) 19.945 mm (0.7852 in.)

³ Values are in Metric units. Values in parentheses are English equivalents.

⁵ Lubricate threads with engine oil prior to assembly.

Specifications

CLEARANCE SPECIFICATIONS ³	KT600	KT715	KT730	KT720	KT724
	KT610	KT725	KT735	KT740	KT722
	KT620	KT725	KT735	KT740	KT722

Connecting Rod

Connecting Rod-to-Crankpin Running Clearance New Max. Wear Limit	0.037/0.083 mm (0.0015/0.0033 in.) 0.098 mm (0.0039 in.)
Connecting Rod-to-Crankpin Side Clearance	0.261/0.67 mm (0.0102/0.0264 in.)
Connecting Rod-to-Piston Pin Running Clearance	0.013/0.032 mm (0.0005/0.0013 in.)
Piston Pin End I.D. New Max. Wear Limit	17.013/17.027 mm (0.6698/0.6704 in.) 17.040 mm (0.6709 in.)

Crankcase

Governor Cross Shaft Bore I.D. New Max. Wear Limit	8.025/8.075 mm (0.3159/0.3179 in.) 8.088 mm (0.3184 in.)
--	---

Crankshaft

End Play (free)	0.075/0.595 mm (0.0030/0.023 in.)
Bore (in crankcase) New Max. Wear Limit	40.974/40.987 mm (1.6131/1.6137 in.) 41.000 mm (1.6142 in.)
Bore (in oil pan) New	40.974/41.000 mm (1.6457/1.6142 in.)
Crankshaft Bore (in oil pan)-to-Crankshaft Running Clearance New	0.039/0.087 mm (0.0015/0.0034 in.)
Flywheel End Main Bearing Journal O.D. - New O.D. - Max. Wear Limit Max. Taper Max. Out-of-Round	40.913/40.935 mm (1.6107/1.6116 in.) 40.840 mm (1.608 in.) 0.022 mm (0.0009 in.) 0.025 mm (0.0010 in.)
Oil Pan End Main Bearing Journal O.D. - New O.D. - Max. Wear Limit Max. Taper Max. Out-of-Round	40.913/40.935 mm (1.6107/1.6116 in.) 40.840 mm (1.608 in.) 0.022 mm (0.0009 in.) 0.025 mm (0.0010 in.)
Connecting Rod Journal O.D. - New O.D. - Max. Wear Limit Max. Taper Max. Out-of-Round	35.950/35.974 mm (1.4154/1.4163 in.) 35.950 mm (1.4154 in.) 0.018 mm (0.0007 in.) 0.025 mm (0.0010 in.)
T.I.R. PTO End, Crank in Engine Entire Crank, in V-Blocks	0.279 mm (0.0110 in.) 0.200 mm (0.0079 in.)

Cylinder Bore

Bore I.D. New Max. Wear Limit Max. Out-of-Round Max. Taper	83.006/83.031 mm (3.2679/3.2689 in.) 83.069 mm (3.2704 in.) 0.120 mm (0.0047 in.) 0.050 mm (0.0020 in.)
--	--

Cylinder Head

Max. Out-of-Flatness	0.076 mm (0.003 in.)
----------------------	----------------------

³ Values are in Metric units. Values in parentheses are English equivalents.

CLEARANCE SPECIFICATIONS ³	KT600	KT715	KT730	KT720	KT724
	KT610 KT620	KT725	KT735	KT740	KT722 KT726

Governor

7 mm Hex End Cross Shaft End Play	0.25/3.15 mm (0.010/0.124 in.)
Governor Cross Shaft-to-Crankcase Running Clearance	0.025/0.126 mm (0.0009/0.0049 in.)
Cross Shaft O.D. New Max. Wear Limit	7.949/8.000 mm (0.3129/0.3149 in.) 7.936 mm (0.3124 in.)
Governor Gear Shaft-to-Governor Running Clearance	0.050/0.210 mm (0.0020/0.0083 in.)
Gear Shaft O.D. New Max. Wear Limit	5.990/6.000 mm (0.2358/0.2362 in.) 5.977 mm (0.2353 in.)

Ignition

Spark Plug Gap	0.76 mm (0.030 in.)
Module Air Gap	0.203/0.305 mm (0.008/0.012 in.)

Piston, Piston Rings, and Piston Pin

Piston-to-Piston Pin Running Clearance	0.006/0.017 mm (0.0002/0.0007 in.)
Pin Bore I.D. New Max. Wear Limit	17.006/17.012 mm (0.6695/0.6698 in.) 17.025 mm (0.6703 in.)
Pin O.D. New Max. Wear Limit	16.995/17.000 mm (0.6691/0.6693 in.) 16.994 mm (0.6691 in.)
Top Compression Ring-to-Groove Side Clearance	0.030/0.070 mm (0.001/0.0026 in.)
Middle Compression Ring-to-Groove Side Clearance	0.030/0.070 mm (0.001/0.0026 in.)
Oil Control Ring-to-Groove Side Clearance	0.060/0.190 mm (0.0022/0.0073 in.)
Top Compression Ring End Gap New Bore Used Bore (Max.)	0.189/0.277 mm (0.0074/0.0109 in.) 0.531 mm (0.0209 in.)
Middle Compression Ring End Gap New Bore Used Bore (Max.)	1.519/1.797 mm (0.0598/0.0708 in.) 2.051 mm (0.0808 in.)
Thrust Face O.D. ⁷ New Max. Wear Limit	82.978 mm (3.2668 in.) 82.833 mm (3.2611 in.)
Piston Thrust Face-to-Cylinder Bore ⁷ Running Clearance New	0.019/0.062 mm (0.0007/0.0024 in.)

³ Values are in Metric units. Values in parentheses are English equivalents.

⁷ Measure 6 mm (0.2362 in.) above bottom of piston skirt at right angles to piston pin.

Specifications



CLEARANCE SPECIFICATIONS ³	KT600	KT715	KT730	KT720	KT724
	KT610	KT725	KT735	KT740	KT722
	KT620	KT726	KT745		

Valves and Valve Tappets





Clearance	0.101/0.152 mm (0.0040/0.0060 in.)
Valve Tappet to Crankcase Running Clearance	0.013/0.073 mm (0.0005/0.0029 in.)
Intake Valve Stem-to-Valve Guide Running Clearance	0.040/0.0780 mm (0.0016/0.0031 in.)
Exhaust Valve Stem-to-Valve Guide Running Clearance	0.052/0.090 mm (0.0020/0.0035 in.)
Intake Valve Guide I.D. New Max. Wear Limit	7.040/7.060 mm (0.2772/0.2780 in.) 7.140 mm (0.2811 in.)
Exhaust Valve Guide I.D. New Max. Wear Limit	7.040/7.060 mm (0.2772/0.2780 in.) 7.160 mm (0.2819 in.)
Valve Guide Reamer Size Standard 0.25 mm O.S.	7.050 mm (0.2776 in.) 7.300 mm (0.2874 in.)
Intake Valve Minimum Lift	8.500 mm (0.3346 in.)
Exhaust Valve Minimum Lift	8.500 mm (0.3346 in.)
Nominal Valve Face Angle	45°

³ Values are in Metric units. Values in parentheses are English equivalents.

GENERAL TORQUE VALUES

English Fastener Torque Recommendations for Standard Applications				
Bolts, Screws, Nuts and Fasteners Assembled Into Cast Iron or Steel				Grade 2 or 5 Fasteners Into Aluminum
Size	 Grade 2	 Grade 5	 Grade 8	
Tightening Torque: N·m (in. lb.) ± 20%				
8-32	2.3 (20)	2.8 (25)	—	2.3 (20)
10-24	3.6 (32)	4.5 (40)	—	3.6 (32)
10-32	3.6 (32)	4.5 (40)	—	—
1/4-20	7.9 (70)	13.0 (115)	18.7 (165)	7.9 (70)
1/4-28	9.6 (85)	15.8 (140)	22.6 (200)	—
5/16-18	17.0 (150)	28.3 (250)	39.6 (350)	17.0 (150)
5/16-24	18.7 (165)	30.5 (270)	—	—
3/8-16	29.4 (260)	—	—	—
3/8-24	33.9 (300)	—	—	—

Tightening Torque: N·m (ft. lb.) ± 20%				
5/16-24	—	—	40.7 (30)	—
3/8-16	—	47.5 (35)	67.8 (50)	—
3/8-24	—	54.2 (40)	81.4 (60)	—
7/16-14	47.5 (35)	74.6 (55)	108.5 (80)	—
7/16-20	61.0 (45)	101.7 (75)	142.5 (105)	—
1/2-13	67.8 (50)	108.5 (80)	155.9 (115)	—
1/2-20	94.9 (70)	142.4 (105)	223.7 (165)	—
9/16-12	101.7 (75)	169.5 (125)	237.3 (175)	—
9/16-18	135.6 (100)	223.7 (165)	311.9 (230)	—
5/8-11	149.5 (110)	244.1 (180)	352.6 (260)	—
5/8-18	189.8 (140)	311.9 (230)	447.5 (330)	—
3/4-10	199.3 (147)	332.2 (245)	474.6 (350)	—
3/4-16	271.2 (200)	440.7 (325)	637.3 (470)	—

Metric Fastener Torque Recommendations for Standard Applications						
Size	Property Class					Noncritical Fasteners Into Aluminum
	 4.8	 5.8	 8.8	 10.9	 12.9	
Tightening Torque: N·m (in. lb.) ± 10%						
M4	1.2 (11)	1.7 (15)	2.9 (26)	4.1 (36)	5.0 (44)	2.0 (18)
M5	2.5 (22)	3.2 (28)	5.8 (51)	8.1 (72)	9.7 (86)	4.0 (35)
M6	4.3 (38)	5.7 (50)	9.9 (88)	14.0 (124)	16.5 (146)	6.8 (60)
M8	10.5 (93)	13.6 (120)	24.4 (216)	33.9 (300)	40.7 (360)	17.0 (150)
Tightening Torque: N·m (ft. lb.) ± 10%						
M10	21.7 (16)	27.1 (20)	47.5 (35)	66.4 (49)	81.4 (60)	33.9 (25)
M12	36.6 (27)	47.5 (35)	82.7 (61)	116.6 (86)	139.7 (103)	61.0 (45)
M14	58.3 (43)	76.4 (56)	131.5 (97)	184.4 (136)	219.7 (162)	94.9 (70)

Torque Conversions	
N·m = in. lb. x 0.113	in. lb. = N·m x 8.85
N·m = ft. lb. x 1.356	ft. lb. = N·m x 0.737

Tools and Aids

Certain quality tools are designed to help you perform specific disassembly, repair, and reassembly procedures. By using these tools, you can properly service engines easier, faster, and safer! In addition, you'll increase your service capabilities and customer satisfaction by decreasing engine downtime.

Here is a list of tools and their source.

NOTE: Not all tools listed are required to service this engine.

SEPARATE TOOL SUPPLIERS

Rehiko Tools
Contact your local Rehiko source of supply.

SE Tools
415 Howard St.
Lapeer, MI 48446
Phone 810-664-2981
Toll Free 800-664-2981
Fax 810-664-8181

Design Technology Inc.
768 Burr Oak Drive
Westmont, IL 60559
Phone 630-920-1300
Fax 630-920-0011

TOOLS

Description	Source/Part No.
Alcohol Content Tester For testing alcohol content (%) in reformulated/oxygenated fuels.	Rehiko 25 455 11-S
Camshaft Endplay Plate For checking camshaft endplay.	SE Tools KLR-82405
Camshaft Seal Protector (Aegis) For protecting seal during camshaft installation.	SE Tools KLR-82417
Dual Gauge Cylinder Leakdown Tester For checking combustion retention and if cylinder, piston, rings, or valves are worn. Individual component available: Adapter 12 mm x 14 mm (Required for leakdown test on XT-6 engines)	Rehiko 25 761 46-S Design Technology Inc. DTI-731-03
Dealer Tool Kit Complete kit of Rehiko required tools. Components of 25 761 39-S Ignition System Tester Dual Gauge Cylinder Leakdown Tester Oil Pressure Test Kit Digital Vacuum/Pressure Tester	Rehiko 25 761 39-S Rehiko 25 455 01-S Rehiko 25 761 46-S Rehiko 25 761 06-S Rehiko 25 455 22-S
Digital Vacuum/Pressure Tester For checking crankcase vacuum. Individual component available: Rubber Adapter Plug	Rehiko 25 455 22-S Design Technology Inc. DTI-721-10
EFI Service Kit For troubleshooting and setting up an EFI engine. Components of 24 761 01-S Fuel Pressure Tester Noid Light 90° Adapter Code Plug, Red Wire Code Plug, Blue Wire Code Plug, Yellow Wire Can Bus Reset Tool, Green Wire Shrader Valve Adapter Hose Wire Probe Set (2 pieces regular wire with clip; 1 piece fused wire) Hose Removal Tool, Dual Size/End (also sold as individual Rehiko tool) K-Line Adapter Jumper Lead Wiring Harness	Rehiko 24 761 01-S Design Technology Inc. DTI-019 DTI-021 DTI-023 DTI-027 DTI-029 DTI-028 DTI-030 DTI-037 DTI-031 DTI-033 Rehiko 25 176 23-S
Rehiko Diagnostic System (KDS) Gen 2 For Laptop or Desktop PC. Components of 25 761 50-S Engine Communication Module 7 Pin to DB9 Cable USB Module to PC Cable 7 Pin to 4 Pin Adapter	Rehiko 25 761 50-S Rehiko 25 761 47-S Rehiko 25 761 48-S Rehiko 25 761 49-S Rehiko 25 761 53-S
Mobile KDS (Wireless) Module For mobile Android or iOS EFI diagnostics. Individual component available: Wireless Diagnostic System Interface Cable	Rehiko 25 761 45-S Rehiko 25 761 44-S

TOOLS

Description	Source/Part No.
Flywheel Puller For properly removing flywheel from engine.	SE Tools KLR-82408
Flywheel Anchor Bolts, Washers, Nuts Tool Used with Flywheel Puller for properly removing flywheel from 5400 Series engine.	Rehiko 25 086 753-S
Hose Removal Tool, Dual Size/End (also available in EFI Service Kit) Used to properly remove fuel hose from engine components.	Rehiko 25 455 20-S
Ignition System Tester For testing output on all systems, including CD.	Rehiko 25 455 01-S
Inductive Tachometer (Digital) For checking operating speed (RPM) of an engine.	Design Technology Inc. DTI-110
Oil Pressure Test Kit For testing/verifying oil pressure on pressure lubricated engines.	Rehiko 25 761 06-S
Rectifier-Regulator Tester (120 volt current) Rectifier-Regulator Tester (240 volt current) For testing rectifier-regulators. Components of 25 761 20-S and 25 761 41-S CS-PRO Regulator Test Harness Special Regulator Test Harness with Diode	Rehiko 25 761 20-S Rehiko 25 761 41-S Design Technology Inc. DTI-031R DTI-033R
Spark Advance Module (SAM) Tester For testing SAM (ASAM and DSAM) on engines with SMART-SPARK™.	Rehiko 25 761 40-S
Starter Servicing Kit (All Starters) For removing and reinstalling drive retaining rings and brushes. Individual component available: Starter Brush Holding Tool (Solenoid Shift)	SE Tools KLR-82411 SE Tools KLR-82416
Stepper Motor Controller Tool For testing operation of stepper motor/Digital Linear Actuator (DLA).	Rehiko 25 455 21-S
Jumper Lead Tool For use with Stepper Motor Controller Tool to test rotary stepper motor.	Rehiko 25 518 43-S
Triad/OHC Timing Tool Set For holding cam gears and crankshaft in timed position while installing timing belt.	Rehiko 28 761 01-S
Valve Guide Reamer (K and M Series) For properly sizing valve guides after installation.	Design Technology Inc. DTI-K828
Valve Guide Reamer O.S. (Command Series) For reaming worn valve guides to accept replacement oversize valves. Can be used in low-speed drill press or with handle below for hand reaming.	Rehiko 25 455 12-S
Reamer Handle For hand reaming using Rehiko 25 455 12-S reamer.	Design Technology Inc. DTI-K830

AIDS

Description	Source/Part No.
Camshaft Lubricant (Valspar ZZ613)	Rehiko 25 357 14-S
Dielectric Grease	Loctite® 51360
Rehiko Electric Starter Drive Lubricant (Inertia Drive)	Rehiko 52 357 01-S
P80 Emulsion Lubricant	Rehiko 25 357 80-S
RTV Silicone Sealant Loctite® 5900® Heavy Body in 4 oz. aerosol dispenser. Only oxime-based, oil resistant RTV sealants, such as those listed, are approved for use. Permatex® the Right Stuff® 1 Minute Gasket™ or Loctite® Nos. 5900® or 5910® are recommended for best sealing characteristics.	Rehiko 25 597 07-S Loctite® 5910® Loctite® Ultra Black 598™ Loctite® Ultra Blue 587™ Loctite® Ultra Copper 5920™ Permatex® the Right Stuff® 1 Minute Gasket™
Spline Drive Lubricant	Rehiko 25 357 12-S

Tools and Aids

FLYWHEEL HOLDING TOOL

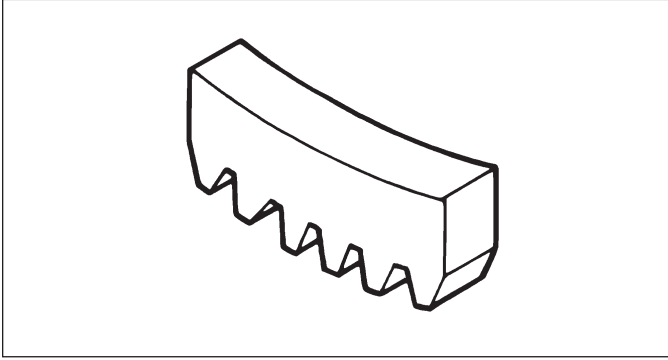

A flywheel holding tool can be made out of an old junk flywheel ring gear and used in place of a strap wrench.

1. Using an abrasive cut-off wheel, cut out a six tooth segment of ring gear as shown.
2. Grind off any burrs or sharp edges.
3. Invert segment and place it between ignition bosses on crankcase so tool teeth engage flywheel ring gear teeth. Bosses will lock tool and flywheel in position for loosening, tightening, or removing with a puller.

ROCKER ARM/CRANKSHAFT TOOL

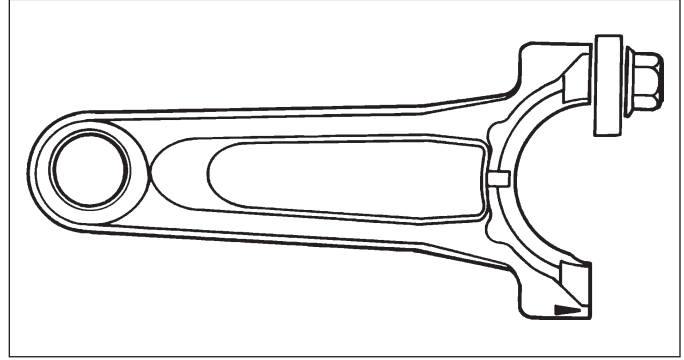

A spanner wrench to lift rocker arms or turn crankshaft may be made out of an old junk connecting rod.

1. Find a used connecting rod from a 10 HP or larger engine. Remove and discard rod cap.
2. Remove studs of a Posi-Lock rod or grind off aligning steps of a Command rod, so joint surface is flat.
3. Find a 1 in. long capscrew with correct thread size to match threads in connecting rod.
4. Use a flat washer with correct I.D. to slip on capscrew and approximately 1 in. O.D. Assemble capscrew and washer to joint surface of rod.

TROUBLESHOOTING GUIDE

When troubles occur, be sure to check simple causes which, at first, may seem too obvious to be considered. For example, a starting problem could be caused by an empty fuel tank.

Some general common causes of engine troubles are listed below and vary by engine specification. Use these to locate causing factors.

Engine Cranks But Will Not Start

- Battery connected backwards.
- Blown fuse.
- Carburetor solenoid malfunction.
- Choke not closing.
- Clogged fuel line or fuel filter.
- Diode in wiring harness failed in open circuit mode.
- DSAI or DSAM malfunction.
- Empty fuel tank.
- Faulty electronic control unit.
- Faulty ignition coil(s).
- Faulty spark plug(s).
- Fuel pump malfunction-vacuum hose clogged or leaking.
- Fuel shut-off valve closed.
- Ignition module(s) faulty or improperly gapped.
- Insufficient voltage to electronic control unit.
- Interlock switch is engaged or faulty.
- Key switch or kill switch in OFF position.
- Low oil level.
- Quality of fuel (dirt, water, stale, mixture).
- SMART-SPARK[™] malfunction.
- Spark plug lead(s) disconnected.

Engine Starts But Does Not Keep Running

- Faulty carburetor.
- Faulty cylinder head gasket.
- Faulty or misadjusted choke or throttle controls.
- Fuel pump malfunction-vacuum hose clogged or leaking.
- Intake system leak.
- Loose wires or connections that intermittently ground ignition kill circuit.
- Quality of fuel (dirt, water, stale, mixture).
- Restricted fuel tank cap vent.

Engine Starts Hard

- Clogged fuel line or fuel filter.
- Engine overheated.
- Faulty ACR mechanism.
- Faulty or misadjusted choke or throttle controls.
- Faulty spark plug(s).
- Flywheel key sheared.
- Fuel pump malfunction-vacuum hose clogged or leaking.
- Interlock switch is engaged or faulty.
- Loose wires or connections that intermittently ground ignition kill circuit.
- Low compression.
- Quality of fuel (dirt, water, stale, mixture).
- Weak spark.

Engine Will Not Crank

- Battery is discharged.
- Faulty electric starter or solenoid.
- Faulty key switch or ignition switch.
- Interlock switch is engaged or faulty.
- Loose wires or connections that intermittently ground ignition kill circuit.
- Pawls not engaging in drive cup.
- Seized internal engine components.

Engine Runs But Misses

- Carburetor adjusted incorrectly.
- Engine overheated.
- Faulty spark plug(s).
- Ignition module(s) faulty or improperly gapped.
- Incorrect crankshaft position sensor air gap.
- Interlock switch is engaged or faulty.
- Loose wires or connections that intermittently ground ignition kill circuit.
- Quality of fuel (dirt, water, stale, mixture).
- Spark plug lead(s) disconnected.
- Spark plug lead boot loose on plug.
- Spark plug lead loose.

Engine Will Not Idle

- Engine overheated.
- Faulty spark plug(s).
- Idle fuel adjusting needle(s) improperly set.
- Idle speed adjusting screw improperly set.
- Inadequate fuel supply.
- Low compression.
- Quality of fuel (dirt, water, stale, mixture).
- Restricted fuel tank cap vent.

Engine Overheats

- Cooling fan broken.
- Excessive engine load.
- Fan belt failed/off.
- Faulty carburetor.
- High crankcase oil level.
- Lean fuel mixture.
- Low cooling system fluid level.
- Low crankcase oil level.
- Radiator, and/or cooling system components clogged, restricted, or leaking.
- Water pump belt failed/broken.
- Water pump malfunction.

Engine Knocks

- Excessive engine load.
- Hydraulic lifter malfunction.
- Incorrect oil viscosity/type.
- Internal wear or damage.
- Low crankcase oil level.
- Quality of fuel (dirt, water, stale, mixture).

Troubleshooting

Engine Loses Power

- Dirty air cleaner element.
- Engine overheated.
- Excessive engine load.
- Restricted exhaust.
- Faulty spark plug(s).
- High crankcase oil level.
- Incorrect governor setting.
- Low battery.
- Low compression.
- Low crankcase oil level.
- Quality of fuel (dirt, water, stale, mixture).

Engine Uses Excessive Amount of Oil

- Loose or improperly torqued fasteners.
- Blown head gasket/overheated.
- Breather reed broken.
- Clogged, broken, or inoperative crankcase breather.
- Crankcase overfilled.
- Incorrect oil viscosity/type.
- Worn cylinder bore.
- Worn or broken piston rings.
- Worn valve stems/valve guides.

Oil Leaks from Oil Seals, Gaskets

- Breather reed broken.
- Clogged, broken, or inoperative crankcase breather.
- Loose or improperly torqued fasteners.
- Piston blow by, or leaky valves.
- Restricted exhaust.

EXTERNAL ENGINE INSPECTION

NOTE: It is good practice to drain oil at a location away from workbench. Be sure to allow ample time for complete drainage.

Before cleaning or disassembling engine, make a thorough inspection of its external appearance and condition. This inspection can give clues to what might be found inside engines (and cause) when it is disassembled.

- Check for buildup of dirt and debris on crankcase, cooling fins, grass screen, and other external surfaces. Dirt or debris on these areas can cause overheating.
- Check for obvious fuel and oil leaks, and damaged components. Excessive oil leakage can indicate a clogged or inoperative breather, worn or damaged seals or gaskets, or loose fasteners.
- Check air cleaner cover and base for damage or indications of improper fit and seal.
- Check air cleaner element. Look for holes, tears, cracked or damaged sealing surfaces, or other damage that could allow unfiltered air into engine. A dirty or clogged element could indicate insufficient or improper maintenance.
- Check carburetor throat for dirt. Dirt in throat is further indication that air cleaner was not functioning properly.
- Check if oil level is within operating range on dipstick. If it is above, sniff for gasoline odor.
- Check condition of oil. Drain oil into a container; it should flow freely. Check for metal chips and other foreign particles.

Sludge is a natural by-product of combustion; a small accumulation is normal. Excessive sludge formation could indicate over rich fuel settings, weak ignition, overextended oil change interval or wrong weight or type of oil was used.

CLEANING ENGINE

	⚠ WARNING
	Cleaning Solvents can cause severe injury or death. Use only in well ventilated areas away from ignition sources.
Carburetor cleaners and solvents are extremely flammable. Follow cleaner manufacturer's warnings and instructions on its proper and safe use. Never use gasoline as a cleaning agent.	

After inspecting external condition of engine, clean engine thoroughly before disassembly. Clean individual components as engine is disassembled. Only clean parts can be accurately inspected and gauged for wear or damage. There are many commercially available cleaners that will quickly remove grease, oil, and grime from engine parts. When such a cleaner is used, follow manufacturer's instructions and safety precautions carefully.

Make sure all traces of cleaner are removed before engine is reassembled and placed into operation. Even small amounts of these cleaners can quickly break down lubricating properties of engine oil.

CRANKCASE VACUUM TEST

	⚠ WARNING
	Carbon Monoxide can cause severe nausea, fainting or death. Avoid inhaling exhaust fumes. Never run engine indoors or in enclosed spaces.
Engine exhaust gases contain poisonous carbon monoxide. Carbon monoxide is odorless, colorless, and can cause death if inhaled.	

	⚠ WARNING
	Rotating Parts can cause severe injury. Stay away while engine is in operation.
Keep hands, feet, hair, and clothing away from all moving parts to prevent injury. Never operate engine with covers, shrouds, or guards removed.	

A partial vacuum should be present in crankcase when engine is operating. Pressure in crankcase (normally caused by a clogged or improperly assembled breather) can cause oil to be forced out at oil seals, gaskets, or other available spots.

Crankcase vacuum is best measured with either a water manometer or a vacuum gauge (inches of water gauge only). Complete instructions are provided in kits.

To test crankcase vacuum with manometer:

1. Insert rubber stopper into oil fill hole. Be sure pinch clamp is installed on hose and use tapered adapters to connect hose between stopper and one manometer tube. Leave other tube open to atmosphere. Check that water level in manometer is at 0 line. Make sure pinch clamp is closed.
2. Start engine and run no-load high speed.
3. Open clamp and note water level in tube.
Level in engine side should be a minimum of 10.2 cm (4 in.) above level in open side.
If level in engine side is less than specified (low/no vacuum), or level in engine side is lower than level in open side (pressure), check for conditions in table below.
4. Close pinch clamp before stopping engine.

To test crankcase vacuum with vacuum/pressure gauge (inches of water gauge only):

1. Remove dipstick or oil fill plug/cap.
2. Install adapter into oil fill/dipstick tube opening, upside down over end of a small diameter dipstick tube, or directly into engine if a tube is not used. Insert barbed gauge fitting into hole in stopper.
3. Run engine and observe gauge reading.

Analog tester—needle movement to left of 0 is a vacuum, and movement to right indicates a pressure.

Digital tester—depress test button on top of tester.

Crankcase vacuum should be a minimum of 10.2 cm (4 in.) of water. If reading is below specification, or if pressure is present, check table below for possible

Condition	Conclusion
Crankcase breather clogged or inoperative.	NOTE: If breather is integral part of valve cover and cannot be serviced separately, replace valve cover and recheck pressure. Disassemble breather, clean parts thoroughly, check sealing surfaces for flatness, reassemble, and recheck pressure.
Seals and/or gaskets leaking. Loose or improperly torque fasteners.	Replace all worn or damaged seals and gaskets. Make sure all fasteners are tightened securely. Use appropriate torque values and sequences when necessary.
Piston blow by or leaky valves (confirm by inspecting components).	Recondition piston, rings, cylinder bore, valves and valves guides.
Restricted exhaust.	Check exhaust screen/spark arrestor (if equipped). Clean or replace as needed. Repair or replace any other damaged/restricted muffler or exhaust system parts.

Troubleshooting

causes and conclusions.

COMPRESSION TEST

A compression test is best performed on a warm engine. Clean any dirt or debris away from base of spark plug(s) before removing them. Be sure battery is fully charged, choke is off, and throttle is wide open during test. Compression should be at least 160 psi and should not vary more than 15% between cylinders.

CYLINDER LEAKDOWN TEST

A cylinder leakdown test can be a valuable alternative to a compression test. By pressurizing combustion chamber from an external air source you can determine if valves or rings are leaking, and how badly.

Cylinder leakdown tester is a relatively simple, inexpensive leakdown tester for small engines. This tester includes a quick-connect for attaching adapter hose and a holding tool.

Dual Gauge Test Procedure

1. Run engine until oil temperature reaches and maintains 150°F (66°C) or more for a minimum of 5 minutes. Ideally, engine should be run under normal load conditions.
2. Remove spark plug(s) and air filter from engine.
3. Rotate crankshaft until piston (of cylinder being tested) is at top dead center (TDC) of compression stroke. Hold engine in this position while testing. Holding tool from kit can be used if PTO end of crankshaft is accessible. Lock holding tool onto crankshaft. Install a 3/8 in. breaker bar into hole/slot of holding tool, so it is perpendicular to both holding tool and crankshaft PTO.

If flywheel end is more accessible, use a breaker bar and socket on flywheel nut/screw to hold it in position. An assistant may be needed to hold breaker bar during testing. If engine is mounted in a piece of equipment, it may be possible to hold it by clamping or wedging a driven component. Just be certain engine cannot rotate off TDC in either direction.

4. Connect an air source (at least 100 PSI) to tool.
5. Turn regulator knob counterclockwise (increase direction). Confirm both gauges read approximately the same air pressure from 0 to 80 PSI. Note any discrepancies between gauges for leakage calculation. Release pressure by turning regulator knob completely counterclockwise before proceeding.
6. Install adapter hose into spark plug hole of cylinder being tested. Use 12 mm x 14 mm adapter if required.
7. Firmly hold engine at TDC. Connect other end of adapter hose to tool quick connect. Turn regulator knob clockwise (increase direction) until left gauge needle reads 20 PSI.

NOTE: When piston is at TDC, little to no holding force should be required when air pressure is applied to cylinder. If excess holding force is required, this indicates piston is not at TDC. Readjust as necessary before proceeding.

8. Slowly turn regulator knob clockwise until left hand gauge maintains selected test pressure (see chart below).

Left Gauge Regulated Pressure Selection
80 PSI Recommended for engines over 200 cc or those exhibiting high leakage at 35 PSI setting.
35 PSI Recommended for single cylinder walk-behind push mower applications.

9. Compare right gauge reading to Test Pressure Chart on next page to identify percentage of leakage. Also refer to Leakdown Test Results chart on next page for color, condition, and action required.
10. For engines exhibiting leakage in yellow or red zone, repeat test procedure. Operate engine under normal load conditions prior to test. Confirm piston is at TDC during test.

NOTE: To prevent damage to gauge assembly, always turn pressure regulator knob to zero (counterclockwise) after each test.

Test Pressure Chart for Dual Gauge Tool

Left Gauge Regulated Pressure Selection	Right Gauge Reading in PSI										
80 PSI Recommended for engines over 200 cc or those exhibiting high leakage at 35 PSI setting.	80	72	64	56	48	40	32	24	16	8	0
35 PSI Recommended for single cylinder walk-behind push mower applications.	35	31.5	28	24.5	21	17.5	14	10.5	7	3.5	0
Percentage of leakage	0%	10%	20%	30%	40%	50%	60%	70%	80%	90%	100%
	Green Zone					Yellow Zone			Red Zone		

Leakdown Test Results

Test Result	Condition	Action
Gauge reading in low (green) zone.	Piston rings and cylinder in good condition.	No further action required.
Gauge reading in moderate (yellow) zone.	Air escaping from crankcase breather and/or dipstick tube.	Some wear present causing leakage from combustion chamber to crankcase. Repair not required at this time if breather system is functioning normally.
	Air escaping from exhaust.	Exhaust valve leakage present, possibly due to carbon deposits. Repair not required. Carbon cleaning could be performed to reduce leakage.
	Air escaping from intake.	Intake valve leakage present, possibly due to carbon deposits. Repair not required. Carbon cleaning could be performed to reduce leakage.
Gauge reading in high (red) zone. Confirm consecutive leakdown test has been performed AFTER engine has been operated under normal load conditions.	Air escaping from crankcase breather and/or dipstick tube.	Excess wear present causing leakage from combustion chamber to crankcase. Breather system will not function normally and will fail crankcase vacuum test if this condition is truly present. Engine disassembly and analysis required to determine root cause and correction.
	Air escaping from exhaust.	Excess exhaust valve leakage present, possibly due to carbon deposits and/or valve to seat sealing issues. Carbon cleaning may reduce leakage. Valve grind and/or component replacement may be necessary. Excess oil consumption and/or excess heat is a suspect cause and must be resolved to prevent reoccurrence.
	Air escaping from intake.	Excess intake valve leakage present, possibly due to carbon deposits and/or valve to seat sealing issues. Carbon cleaning may reduce leakage. Valve grind and/or component replacement may be necessary. Excess oil consumption through intake valve and/or excess heat is a suspect cause and must be resolved to prevent reoccurrence. Inspect breather system components and intake valve stem sealing.

Air Cleaner/Intake

AIR CLEANER

These systems are CARB/EPA certified and components should not be altered or modified in any way.

Air Cleaner Components

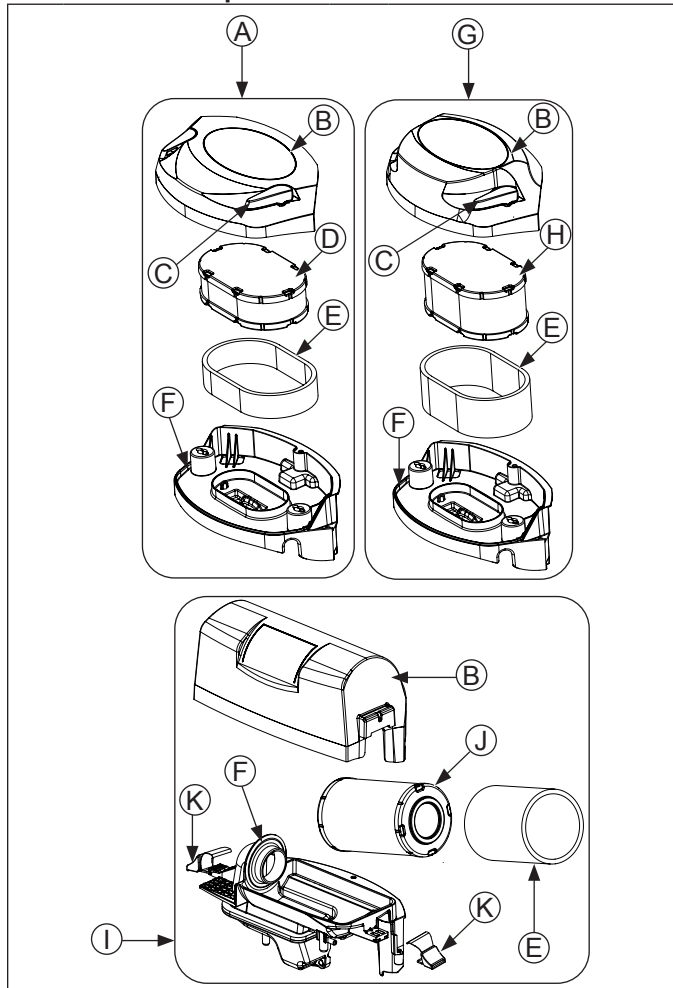

A	Low-Profile Air Cleaner (LPAC)	B	Air Cleaner Cover
C	Air Cleaner Cover Lever	D	LPAC Element
E	Precleaner	F	Air Cleaner Base
G	High Performance Air Cleaner	H	High Performance Element
I	PRO Performance Air Cleaner	J	PRO Performance Element
K	Bail		

NOTE: Operating engine with loose or damaged air cleaner components could cause premature wear and failure. Replace all bent or damaged components.

NOTE: Paper element cannot be blown out with compressed air.

Rotate air cleaner cover levers outward to unlock cover; remove air cleaner cover.

or

Move bails on air cleaner cover up; remove latches from cover; remove cover.

Precleaner (if equipped)

1. Remove precleaner from paper element.
2. Replace or wash precleaner in warm water with detergent. Rinse and allow to air dry.
3. Lightly oil precleaner with new engine oil; squeeze out excess oil.
4. Reinstall precleaner over paper element.

Paper Element

1. Remove element from base; service precleaner. Discard element.
2. Install precleaner over new paper element and install on base.

Position air cleaner cover with levers outward over air cleaner; turn levers inward to lock.

or

Reinstall cover; place latches onto cover; pull down bails to secure cover.

Air Cleaner Base

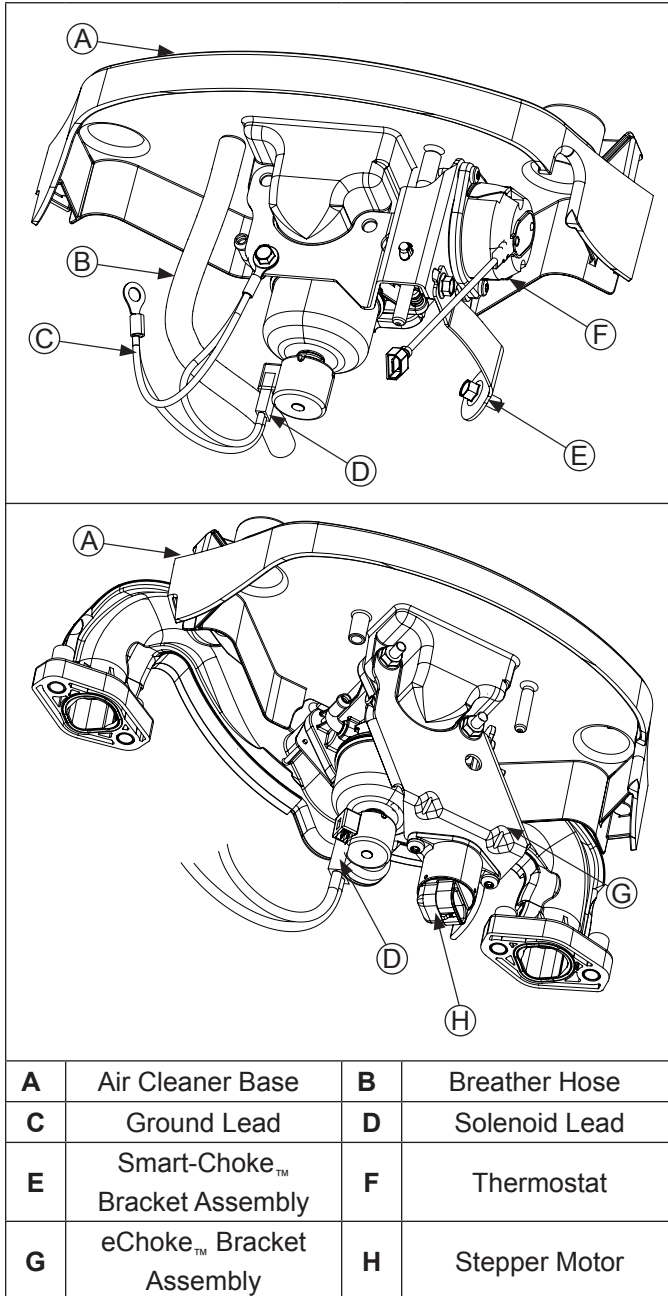

If air cleaner base requires removal, proceed as follows:

1. Remove mounting screws for fuel pump (if equipped), and blower housing.
2. Raise or remove blower housing for access to air cleaner base.
3. Remove air cleaner components from base.
4. Remove nuts securing air cleaner base onto mounting studs.
5. Disconnect ground lead and fuel shut-off solenoid lead (if equipped).
6. If equipped with eChoke™, disconnect connector from stepper motor.
7. Remove Smart-Choke™ or eChoke™ bracket assembly (if equipped).
8. Disconnect choke linkage from carburetor assembly.
9. Disconnect breather hose from air cleaner base, then remove base and gasket.
10. Reverse procedure to reassemble components. Torque nuts to 6.2-7.3 N·m (55-65 in. lb.). Torque blower housing screws to 4.0 N·m (35 in. lb.), and front HI-LO screws to 2.8 N·m (25 in. lb.). Torque Smart-Choke™ bracket assembly screw to 5 N·m (45 in. lb.).

BREATHER TUBE

Ensure both ends of breather tube are properly connected.

AIR COOLING

	WARNING
	<p>Hot Parts can cause severe burns. Do not touch engine while operating or just after stopping.</p>
<p>Never operate engine with heat shields or guards removed.</p>	

Proper cooling is essential. To prevent over heating, clean screens, cooling fins, and other external surfaces of engine. Avoid spraying water at wiring harness or any electrical components. Refer to Maintenance Schedule.

Disassembly/Reassembly

NOTE: On engines equipped with eChoke™, stepper motor has a special retract routine that can be activated to ensure motor is in correct position prior to removal or upon replacement of stepper motor when a problem is shown to exist with stepper motor assembly and carburetor. Activation of this routine will occur by initiating three (3) consecutive Key On–Off cycles. Every Key On and Off should be > 2 seconds and < 3.5 seconds. Note that if no other connections are disturbed, stepper motor will be repositioned at next key ON and master module will go back to normal choke operation mode.

Fuel System

Typical carbureted fuel system and related components include:

- Fuel tank.
- Fuel lines.
- In-line fuel filter.
- Fuel pump.
- Carburetor.

Fuel from tank is moved through in-line filter and fuel lines by fuel pump. Fuel then enters carburetor float bowl and is drawn into carburetor body and mixed with air. This fuel-air mixture is then burned in engine combustion chamber.

FUEL RECOMMENDATIONS

Refer to Maintenance.

FUEL LINE

Low permeation fuel line must be installed on carbureted Rehlko engines to maintain EPA and CARB regulatory compliance.

FUEL PUMP

Some engines use a pulse style fuel pump. Pumping action of pulse style pumps is created by oscillation of positive and negative pressures within crankcase. This pressure is transmitted to pulse pump through rubber hose connected between pump and crankcase. Pumping action causes diaphragm on inside of pump to pull fuel in on its downward stroke and to push it into carburetor on its upward stroke. Two check valves prevent fuel from going backward through pump.

FUEL SYSTEM TESTS

When engine starts hard or turns over but will not start, fuel system might be causing problems. Test fuel system by performing following test.

1. Check for fuel in combustion chamber.
 - a. Disconnect and ground spark plug leads.
 - b. Close choke on carburetor.
 - c. Crank engine several times.
 - d. Remove spark plug and check for fuel at tip.
2. Check for fuel flow from tank to fuel pump.
 - a. Remove fuel line from inlet fitting of fuel pump.
 - b. Hold line below bottom of tank. Open shut-off valve (if equipped) and observe flow.
3. Check operation of fuel pump.
 - a. Remove fuel line from inlet fitting of carburetor.
 - b. Crank engine several times and observe flow.

Performance

Minimum fuel delivery rate must be 7.5 l/hr. (2 gal./hr.) with a pressure at 0.3 psi and a fuel lift of 24 in. A 1.3 l/hr. (0.34 gal./hr.) fuel rate must be maintained at 5 Hz.

Fuel Pump Replacement

NOTE: Make sure orientation of new pump is consistent with removed pump. Internal damage may occur if installed incorrectly.

To replace pulse pump follow these steps. Note orientation of pump before removing.

1. Disconnect fuel lines from inlet, outlet, and pulse fittings on fuel pump.
2. Remove screws and take off pump.
3. Connect pulse line to new fuel pump and make sure opposite end is properly connected into valve cover.
4. Attach new fuel pump using screws. Torque screws to 2.8 N·m (25 in. lb.).
5. Reconnect fuel lines to inlet and outlet fittings and secure with clamps.

AUTO CHOKE (if equipped)

If engine is equipped with Smart-Choke™ or eChoke™, identify design and follow appropriate troubleshooting procedures starting on page 36 of this manual.

Condition

Conclusion

Condition	Conclusion
Fuel at tip of spark plug.	Fuel is reaching combustion chamber.
No fuel at tip of spark plug.	Check fuel flow from fuel tank (step 2).
Fuel flows from fuel line.	Check for faulty fuel pump (step 3). If fuel pump is working, check for faulty carburetor. Refer to Carburetor.
No fuel flow from fuel line.	Check fuel tank cap vent, fuel pickup screen, in-line filter, shut-off valve, and fuel line. Correct any observed problem and reconnect line.
Fuel line condition.	Check for a clogged fuel line. If fuel line is unobstructed, check for overfilled crankcase and/or oil in pulse line. If checks don't reveal cause of problem, replace pump.

CARBURETOR

	⚠ WARNING
	Explosive Fuel can cause fires and severe burns. Do not fill fuel tank while engine is hot or running.
Gasoline is extremely flammable and its vapors can explode if ignited. Store gasoline only in approved containers, in well ventilated, unoccupied buildings, away from sparks or flames. Spilled fuel could ignite if it comes in contact with hot parts or sparks from ignition. Never use gasoline as a cleaning agent.	

Keihin One-Barrel Carburetor Components

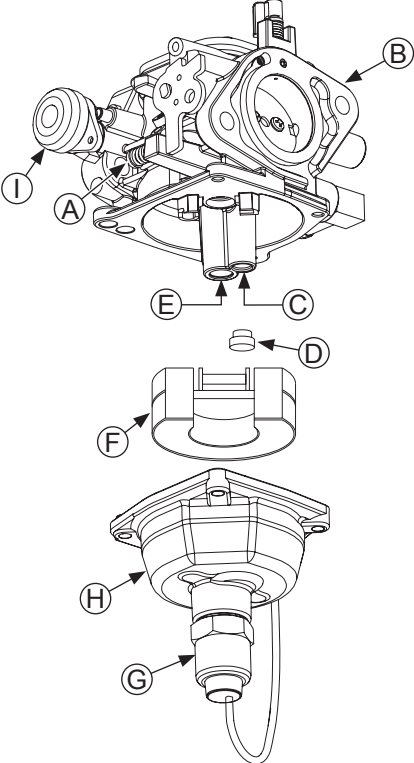

A	Idle Speed Screw	B	Carburetor Body
C	Idle Jet	D	Plug
E	Main Jet	F	Float
G	Shut-off Solenoid Assembly	H	Fuel Bowl
I	Choke Lever		

Walbro One-Barrel Carburetor Components

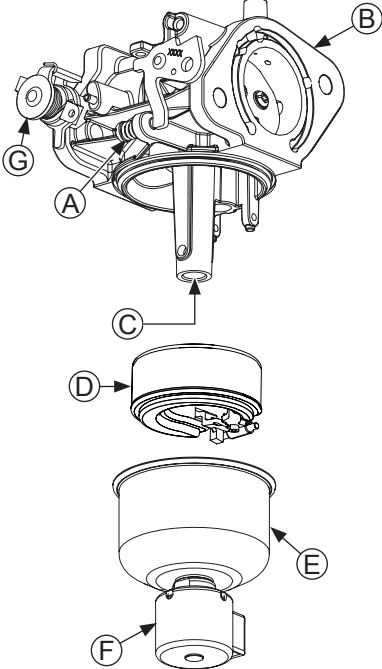

A	Idle Speed Screw	B	Carburetor Body
C	Main Jet	D	Float
E	Fuel Bowl	F	Shut-off Solenoid Assembly
G	Choke Lever		

Engines in this series are equipped with either a Keihin or Walbro fixed main jet carburetor. Most carburetors utilize a fuel shut-off solenoid and feature a self-relieving choke.

Troubleshooting Checklist

When engine starts hard, runs rough, or stalls at low idle speed, check these areas before adjusting or disassembling carburetor.

1. Make sure fuel tank is filled with clean, fresh gasoline.
2. Make sure fuel tank cap vent is not blocked and is operating properly.
3. Make sure fuel is reaching carburetor. This includes checking fuel shut-off valve, fuel tank filter screen, in-line fuel filter, fuel lines and fuel pump for restrictions or faulty components as necessary.
4. Make sure air cleaner base and carburetor are securely fastened to engine using gaskets in good condition.
5. Make sure air cleaner element (including pre-cleaner if equipped) is clean and all air cleaner components are fastened securely.
6. Make sure ignition system, governor system, exhaust system, and throttle and choke controls are operating properly.

Fuel System

Troubleshooting-Carburetor Related Causes

Condition	Possible Cause	Conclusion
Engine runs rich (indicated by black, sooty exhaust smoke, misfiring, loss of speed and power, governor hunting, or excessive throttle opening).	Clogged air cleaner.	Clean or replace air cleaner.
	Choke partially closed during operation.	Check choke lever/linkage to ensure choke is operating properly.
	Float level is set too high.	Adjust float (Keihin only, Walbro not adjustable).
	Dirt under fuel inlet needle.	Remove needle; clean needle and seat and blow with compressed air.
	Bowl vent or air bleeds plugged.	Clean vent, ports, and air bleeds. Blow out all passages with compressed air.
Engine runs lean (indicated by misfiring, loss of speed and power, governor hunting, or excessive throttle opening).	Leaky, cracked, or damaged float.	Submerge float to check for leaks.
	Float level is set too low.	Adjust float (Keihin only, Walbro not adjustable).
Fuel leaks from carburetor.	Idle holes plugged; dirt in fuel delivery channels.	Clean main fuel jet and all passages; blow out with compressed air.
	Float level set too high.	Adjust float (Keihin only, Walbro not adjustable).
	Dirt under fuel inlet needle.	Remove needle; clean needle and seat and blow with compressed air.
	Bowl vents plugged.	Blow out with compressed air.
	Carburetor bowl gasket leaks.	Replace gasket.

FUEL SYSTEM

Fuel Shut-off Solenoid

Most carburetors are equipped with a fuel shut-off solenoid. Solenoid is attached to fuel bowl. Solenoid has a spring-loaded pin that retracts when 12 volts is applied to lead, allowing fuel flow to main jet. When current is removed, pin extends blocking fuel flow.

Below is a simple test, performed with engine off, that can determine if solenoid is functioning properly:

1. Shut off fuel and remove solenoid from carburetor. When solenoid is loosened and removed, gas will leak out of carburetor. Have a container ready to catch fuel.
2. Wipe tip of solenoid with a shop towel or blow with compressed air to remove any remaining fuel. Take solenoid to a location with good ventilation and no fuel vapors present. You will also need a 12 volt power source that can be switched on and off.
3. Be sure power source is switched OFF. Connect positive power source lead to red lead of solenoid. Connect negative power source lead to solenoid body.
4. Turn power source ON and observe pin in center of solenoid. Pin should retract with power ON and return to its original position with power OFF. Test several times to verify operation.

Carburetor Circuits

Float

Fuel level in bowl is maintained by float and fuel inlet needle. Buoyant force of float stops fuel flow when engine is at rest. When fuel is being consumed, float will drop and fuel pressure will push inlet needle away from seat, allowing more fuel to enter bowl. When demand ceases, buoyant force of float will again overcome fuel pressure, rising to predetermined setting and stop flow.

Slow and Mid-Range

At low speeds engine operates only on slow circuit. As a metered amount of air is drawn through slow air bleed jets, fuel is drawn through main jet and further metered through slow jet. Air and fuel are mixed in body of slow jet and exit to idle progression (transfer port) chamber. From idle progression chamber, air fuel mixture is metered through idle port passage. At low idle air/fuel mixture is controlled by setting of idle fuel adjusting screws. This mixture is then mixed with main body of air and delivered to engine. As throttle plate opening increases, greater amounts of air/fuel mixture are drawn in through fixed and metered idle progression holes. As throttle plate opens further, vacuum signal becomes great enough at venturi so main circuit begins to work.

Main (high-speed)

At high speeds/loads engine operates on main circuit. As a metered amount of air is drawn through air jet, fuel is drawn through main jet. Air and fuel are mixed in main nozzles then enters main body of airflow where further mixing of fuel and air occurs. This mixture is then delivered to combustion chamber. Carburetor has a fixed main circuit; no adjustment is possible.

Carburetor Adjustments

NOTE: Carburetor adjustments should be made only after engine has warmed up.

Carburetor is designed to deliver correct fuel-to-air mixture to engine under all operating conditions. Main fuel jet is calibrated at factory and is not adjustable. Idle fuel adjusting needles are also set at factory and are not adjustable.



Idle Speed (RPM) Adjustment

1. Hold governor lever away from carburetor so throttle lever is against idle speed (RPM) adjustment screw of carburetor. Start engine and allow to warm up, then adjust screw to set approximately 1450 RPM. Check speed using a tachometer. Turn adjustment screw (inner) clockwise (in) to increase or counterclockwise (out) to decrease speed.
2. Release governor lever and check that throttle lever is in idle position. Obtain equipment manufacturer's recommended idle speed (1750 RPM). All engines have a bendable tab that is used to set this speed. A pliers should be used to bend this tab to achieve recommended speed. Governed idle speed (RPM) is typically 300 RPM (approximate) higher than low idle speed.
3. Move throttle lever to wide-open/full throttle position and hold in this position. Turn high speed screw to obtain intended high speed no-load RPM. Governed idle speed must be set before making this adjustment.

High Speed (RPM) Adjustment

1. With engine running, move throttle control to fast.
2. Turn inner adjustment screw outward to decrease, or inward to increase RPM speed.

Carburetor Servicing

	⚠ WARNING
	Accidental Starts can cause severe injury or death.
	Disconnect and ground spark plug lead(s) before servicing.
Before working on engine or equipment, disable engine as follows: 1) Disconnect spark plug lead(s). 2) Disconnect negative (-) battery cable from battery.	

NOTE: Main and slow jets are fixed and size specific and can be removed if required. Fixed jets for high altitudes are available.

- Inspect carburetor body for cracks, holes, and other wear or damage.
- Inspect float for cracks, holes, and missing or damaged float tabs. Check float hinge and shaft for wear or damage.
- Inspect fuel inlet needle and seat for wear or damage.
- Inspect spring loaded choke plate to make sure it moves freely on shaft.

Float Setting (Keihin Only)

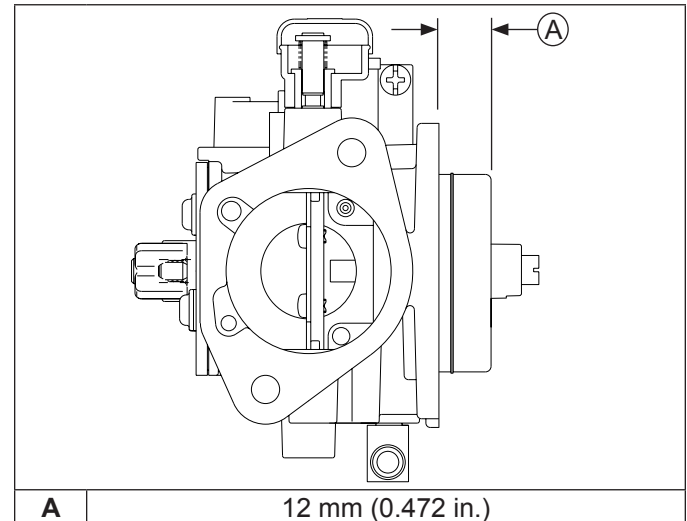

NOTE: Inlet needle center pin is spring loaded. Make sure float assembly rests against fuel inlet needle, without depressing center pin.

1. Perform removal procedures for appropriate air cleaner and carburetor outlined in Disassembly.
2. Clean exterior surfaces of dirt or foreign material before disassembling carburetor. Remove bowl retaining screws, or solenoid assembly, and carefully separate fuel bowl from carburetor. Do not damage fuel bowl O-rings. Transfer any remaining fuel into an approved container. Save all parts.
3. Remove float pin (some carburetors may have a screw which requires removal), and inlet needle. Seat for inlet needle is not serviceable and should not be removed.
4. Remove two screws securing top cover, gasket, and ground lead (Keihin carburetors only). Discard gasket and screws only.
5. Remove idle speed adjusting screw and spring from carburetor. Discard parts.
6. Clean carburetor bowl and inlet seat areas as required.
7. Carefully remove main jet from carburetor. After main jet is removed, on some carburetors, main nozzle can be removed through bottom of main tower. Note orientation/direction of nozzle. Save parts for cleaning and reuse.
8. Position of slow jet varies and is removable only on some styles of carburetors. See correct illustration for corresponding style of carburetor showing location. Save parts for cleaning and reuse unless a jet kit is also being installed. Clean slow jet using compressed air. Do not use wire or carburetor cleaner.
9. Carburetor is now disassembled for appropriate cleaning and installation of parts in overhaul kit. Further disassembly is not necessary. Throttle shaft assembly, fuel inlet seat and idle fuel adjustment screw are non-serviceable items and should not be removed. Choke shaft assembly is serviceable, however it should not be removed unless a choke repair kit will be installed.

Fuel System

For Keihin Carburetors Only

To install choke repair kit go to step 10, otherwise go to step 21.

10. Remove and discard plastic cap from top of choke lever/shaft assembly.
11. Note position of spring legs and choke plate for correct reassembly later.
12. Remove two screws attaching choke plate to choke shaft. Pull shaft out of carburetor body and discard removed parts.
13. Use a screw extractor (easy out) and remove original choke shaft bushing with old choke lever from carburetor housing. Save bushing to use as a driver for installing new bushing. Discard old lever.
14. Clean I.D. of both choke shaft bores as required.
15. Insert new bushing through new choke lever from outside, and start bushing in outer shaft bore. Position choke lever so that protruding boss on carburetor housing is between two stops formed in choke lever.
16. Turn old bushing upside down and use it as a driver to carefully press or tap new bushing into carburetor body until it bottoms. Check that choke lever pivots freely without restriction or binding.
17. Install new return spring onto new choke shaft, so upper leg of spring is between two formed stops on end of choke shaft.
18. Slide choke shaft and spring, into carburetor. Pivot (preload) shaft and set inner leg of spring, against formed stop within choke lever, as originally assembled. Opposing leg of spring must still be between formed stops of choke shaft.
19. Place a drop of Loctite® on threads of each new screw. Install new choke plate to flat side of choke shaft and start two screws. Larger cutout must be on right. Close choke and check plate alignment within carburetor throat, then tighten screws securely. Do not overtighten.
20. Check for proper operation and free movement of parts. Install new cap.
21. Clean carburetor body, jets, vent ports, seats, etc., using a good commercially available carburetor solvent. Use clean, dry compressed air to blow out internal channels and ports. Inspect and thoroughly check carburetor for cracks, wear, or damage. Inspect fuel inlet needle seat for wear or damage. Check spring loaded choke plate to make sure it moves freely on shaft.
22. Clean carburetor float bowl as required.
23. Install main nozzle and main jet into tower of carburetor body.
24. Install slow jet and new plug into end of slow jet tube.
25. Attach inlet needle to metal tang of float with wire clip. Formed 90° lip of metal tang should point up, with needle valve hanging down.
26. Install new float and new inlet needle down into seat and carburetor body. Insert new pivot pin through float hinge and secure with new retaining screw.
27. Hold carburetor body so float assembly hangs vertically and rests lightly against fuel inlet needle. Inlet needle should be fully seated but center pin of needle (on retainer clip end) should not be depressed. Check float height adjustment.
28. Correct float height adjustment is 12.0 mm (0.472 in.) measured from float bottom to body of carburetor. Adjust float height by carefully bending metal tang of float.
29. When proper float height is obtained, carefully install new O-ring for fuel bowl.
30. Install fuel bowl onto carburetor. Secure with four original screws. Torque screws to $2.5 \pm .3$ N·m (23 ± 2.6 in. lb.).
31. Install new cover gasket and top cover on carburetor. Secure with two large-head screws and attach ground lead (if equipped with a fuel solenoid), to original screw location. Torque top cover screws to $2.5 \pm .3$ N·m (23 ± 2.6 in. lb.).
32. Place new spring onto idle speed adjusting screw and install into carburetor. Thread in until 3 or 4 threads are exposed, as an initial adjustment.
33. Reinstall carburetor using appropriate new carburetor and air cleaner base gaskets.
34. Reconnect spark plug lead(s) and negative (–) battery cable. Start engine and perform Idle Speed (RPM) Adjustment.

For Walbro Carburetors Only

10. Clean carburetor body, jets, vent ports, seats, etc., using a good commercially available carburetor solvent. Use clean, dry compressed air to blow out internal channels and ports. Inspect and thoroughly check carburetor for cracks, wear, or damage. Inspect fuel inlet needle seat for wear or damage. Check spring loaded choke plate to make sure it moves freely on shaft.
11. Clean carburetor float bowl as required.
12. Install main nozzle and main jet into tower of carburetor body.
13. Install new solenoid gasket on solenoid. Reassemble fuel bowl and solenoid.
14. Reinstall carburetor using appropriate new carburetor and air cleaner base gaskets.
15. Reconnect spark plug lead(s) and negative (–) battery cable. Start engine and perform Idle Speed (RPM) Adjustment.

High Altitude Operation

If this engine is operated at an altitude of 4000 ft. (1219 meters) or above, a high altitude carburetor kit is required. To obtain high altitude carburetor kit information or to find a Rehlko authorized dealer, visit Engines.rehlko.com or call 1-800-544-2444 (U.S. and Canada).

This engine should be operated in its original configuration below 4000 ft. (1219 meters).

Operating this engine with the wrong engine configuration at a given altitude may increase its emissions, decrease fuel efficiency and performance, and result in damage to the engine.

Smart-Choke™

An air vane deflector assembly that operates by air from cooling fan opens choke partially when engine is running. When engine is cold, a spring on air vane deflector assembly, in conjunction with a bimetallic spring, holds choke closed for starting. A bimetallic spring reacts to heat generated by electrical resistance as engine is running and opens choke plate position. When engine is warm, bimetallic spring holds choke completely open, while engine is running. Choke will be 2/3 closed when warm and not running. These two elements work together to operate a smooth choke system that facilitates easy reliable starting.

As of this revision, there is an original design and an updated design. Identify design on engine being serviced and follow those details to diagnose and troubleshoot.

Original Design Smart-Choke™

Original design had a 3-terminal oil pressure switch as part of system. Several other components in original design have had improvements.

Thermostat

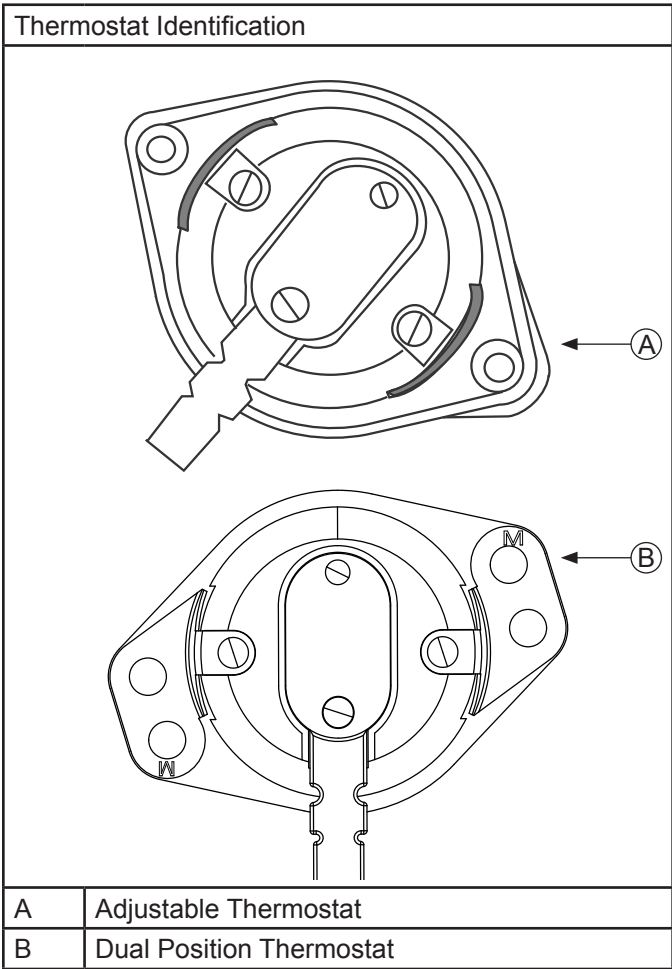

First thermostat was an adjustable thermostat that needs to be reset if mounting screws are loosened or removed. This was then replaced by a dual position thermostat with mounting holes for CDI ignition position or MDI ignition position.

Air Vane

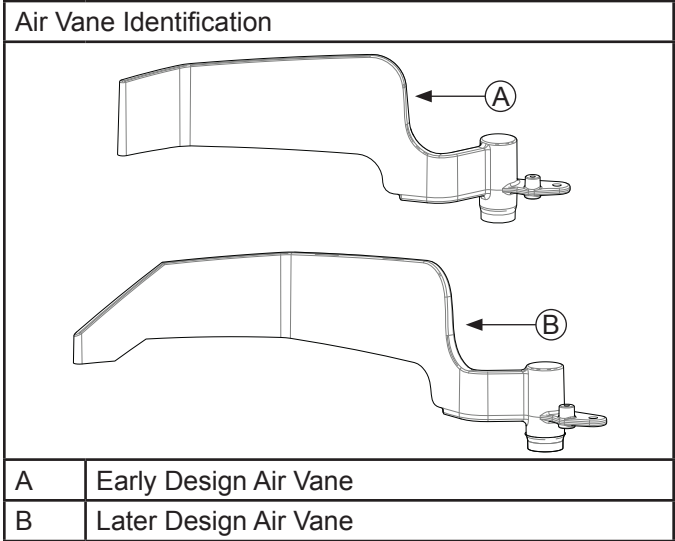

Early design air vane was used with an adjustable thermostat or a dual position thermostat mounted using proper holes for ignition system on engine (plain holes for CDI or M holes for MDI).

Later design air vane requires a dual position thermostat ALWAYS mounted using plain holes.

Deflector Support Tab (if equipped)
Some early production engines were built with a deflector support tab. This separate part was eliminated and molded onto intake manifold.

Updated Design Smart-Choke™

Updated design removed oil pressure switch from this system and also replaced a 3-terminal oil pressure switch with either a 1-terminal oil pressure switch (for user notification of low oil) or a plug. Wiring harness also changed for proper connection to a 1-terminal oil pressure switch and a 5 amp fuse was added in power supply line to thermostat.

Fuel System

Smart-Choke™ Components

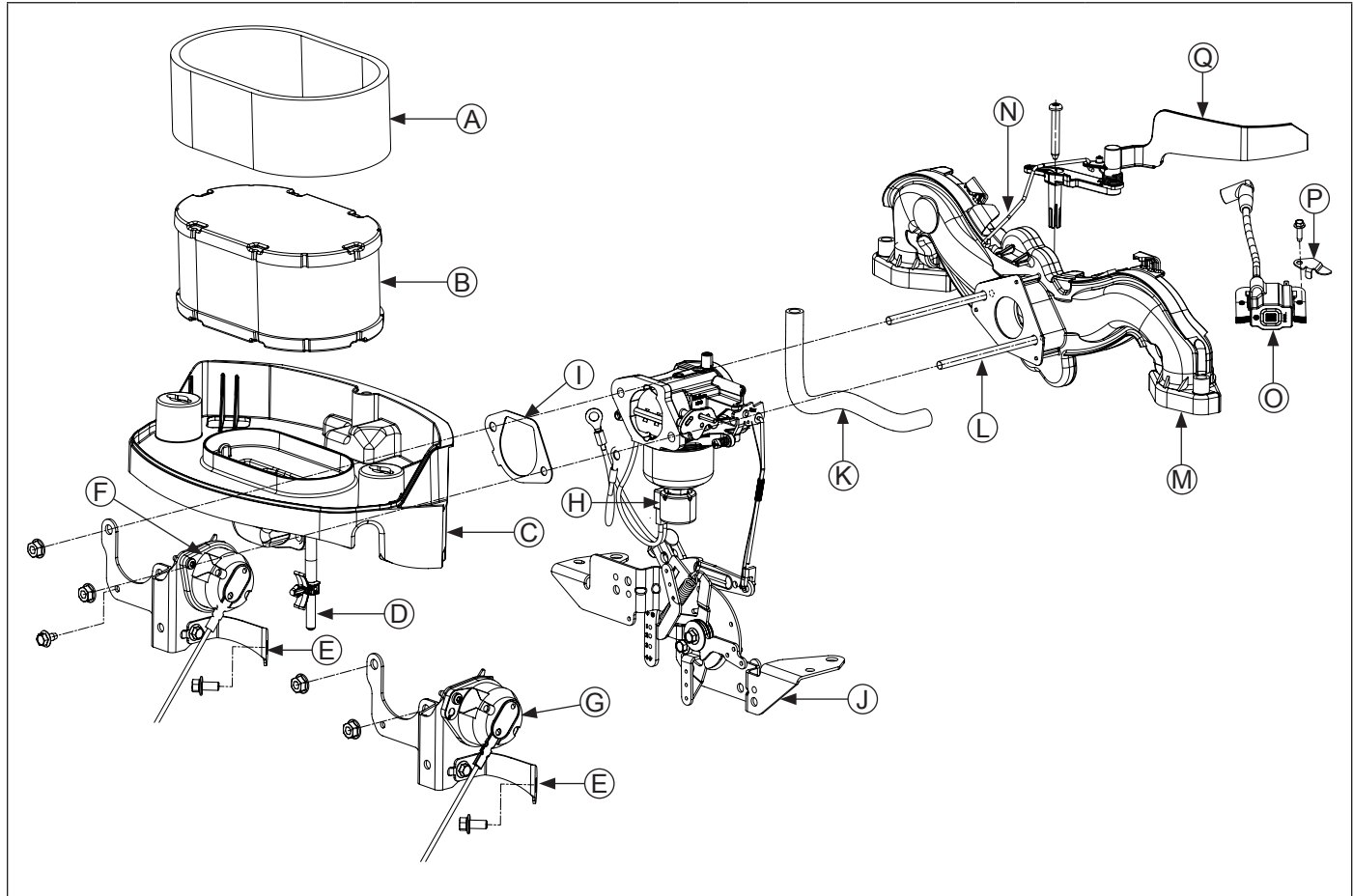

A	Precleaner	B	Paper Element	C	Air Cleaner Base	D	Evap Hose
E	Smart-Choke™ Bracket Assembly	F	Adjustable Thermostat	G	Dual Position Thermostat	H	Solenoid Lead
I	Air Cleaner Gasket	J	Control Assembly	K	Breather Hose	L	Stud
M	Intake Manifold	N	Choke Unloaded Linkage	O	Ignition Module	P	Deflector Support Tab (if Equipped)
Q	Air Vane Deflector						

Troubleshooting Smart-Choke™ Related Causes

Condition	Possible Cause	Conclusion
Engine starts hard, runs rough, or stalls at idle speed.	Choke not closing.	Check choke lever/linkage to ensure choke is operating properly.
		Check that bimetallic spring actuates freely.
Engine runs rich (indicated by black, sooty exhaust smoke, misfiring, loss of speed and power, governor hunting, or excessive throttle opening).	Choke partially closed during operation.	Check choke lever/linkage to ensure choke is operating properly.
		Check that air vane is operating freely.
	Choke not opening.	Check choke lever/linkage to ensure choke is operating properly.
		Check choke thermostat bracket assembly.

Smart-Choke™ System Troubleshooting

Original Design Smart-Choke™ System Oil Pressure Switch

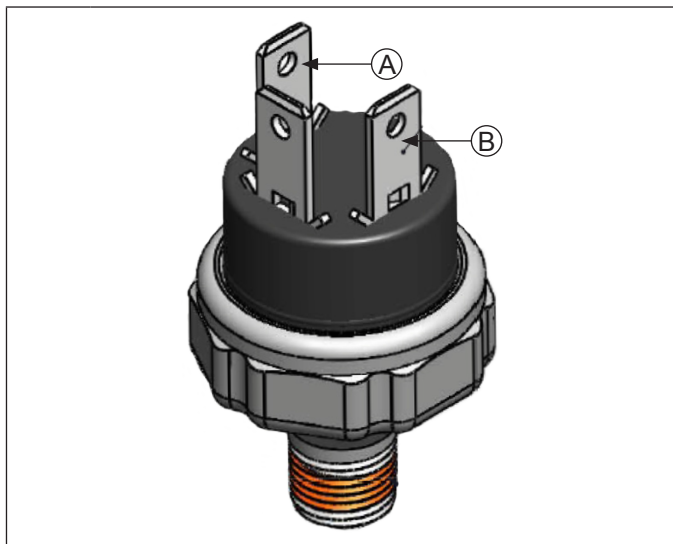

A	Power In Terminal
B	Power Out Terminal

These procedures are to be performed on a cold engine.

NOTE: Bimetallic spring assembly is pre-set at factory. DO NOT attempt to adjust/change its settings.

NOTE: Do not remove or loosen thermostat screws. Position is set at factory.

NOTE: Thermostat temperature must be at room temperature before testing.

1. Remove air cleaner cover, and air cleaner from air cleaner base.
2. Choke plate should be fully closed when engine is cold.
3. There should be light spring tension holding choke closed.
4. There should not be any binding when choke shaft assembly is rotated, which could cause choke to remain partially open.
5. Remove blower housing.
6. Check choke linkage and air vane deflector assembly for binding or debris build up. Gently actuate linkage and observe that choke plate has full range of movement (open and close).
7. Unplug red wire with black tracer power lead of bimetallic spring assembly. Measure heat circuit resistance of choke thermostat assembly, with a volt ohm meter at room temperature (68°F/20°C).

8. Original Design Smart-Choke™ System: Attach one wire of meter to red wire w/yellow tracer terminal of assembly, and other wire to ground of bracket or to ground strip of assembly body.

Updated Design Smart-Choke™ System: Attach one wire of meter to red wire w/black tracer terminal of assembly, and other wire to ground of bracket or to ground strip of assembly body."

Thermostat resistance should read 15 ohms (+/- 10 ohms). If assembly is warm, allow unit to cool to room temperature (68°F/20°C) for accurate testing. If an infinite (open) reading is found, replace bimetallic spring choke bracket assembly. Air vane linkage will not open choke plate fully when cold and will not close choke plate fully when engine is warm.

9. Reinstall blower housing.
10. Start engine. Upon start up, choke plate should be 1/3 closed. Choke plate should gradually change to full open position after 2 to 2-1/2 minutes of running. This action is performed by bimetallic spring assembly being heated. If choke plate fails to open, recheck linkage for binding.
11. With engine running (Original Design Smart-Choke™ System) or key switch ON (Updated Design Smart-Choke™ System), check voltage at bimetallic spring choke bracket assembly. Using a DVOM, attach black lead of meter to ground screw on assembly bracket, and red lead of meter to red wire w/black tracer.
12. Select DC VOLTS on your meter. You should see a minimum of 12 volts DC.
If no voltage is present, test for voltage at oil pressure switch (Original Design Smart-Choke™ System).
If voltage is present at power in terminal but not at power out terminal when engine is running, pressure switch is potentially faulty. Remove switch and install a pressure test gauge and start engine. Consult troubleshooting section of this manual for oil pressure testing instructions. If adequate pressure is found, replace pressure switch and confirm operation/voltage readings.
13. If linkage is free and choke plate fails to open fully after 2 minutes, check spring tension of bimetallic assembly. If necessary, replace bimetallic spring choke bracket assembly.
14. Reinstall air cleaner element and secure cover.

Thermostat

Different styles of thermostats are used. Identify style on engine and follow appropriate procedure to reset or install.

Fuel System

Adjustable Thermostat

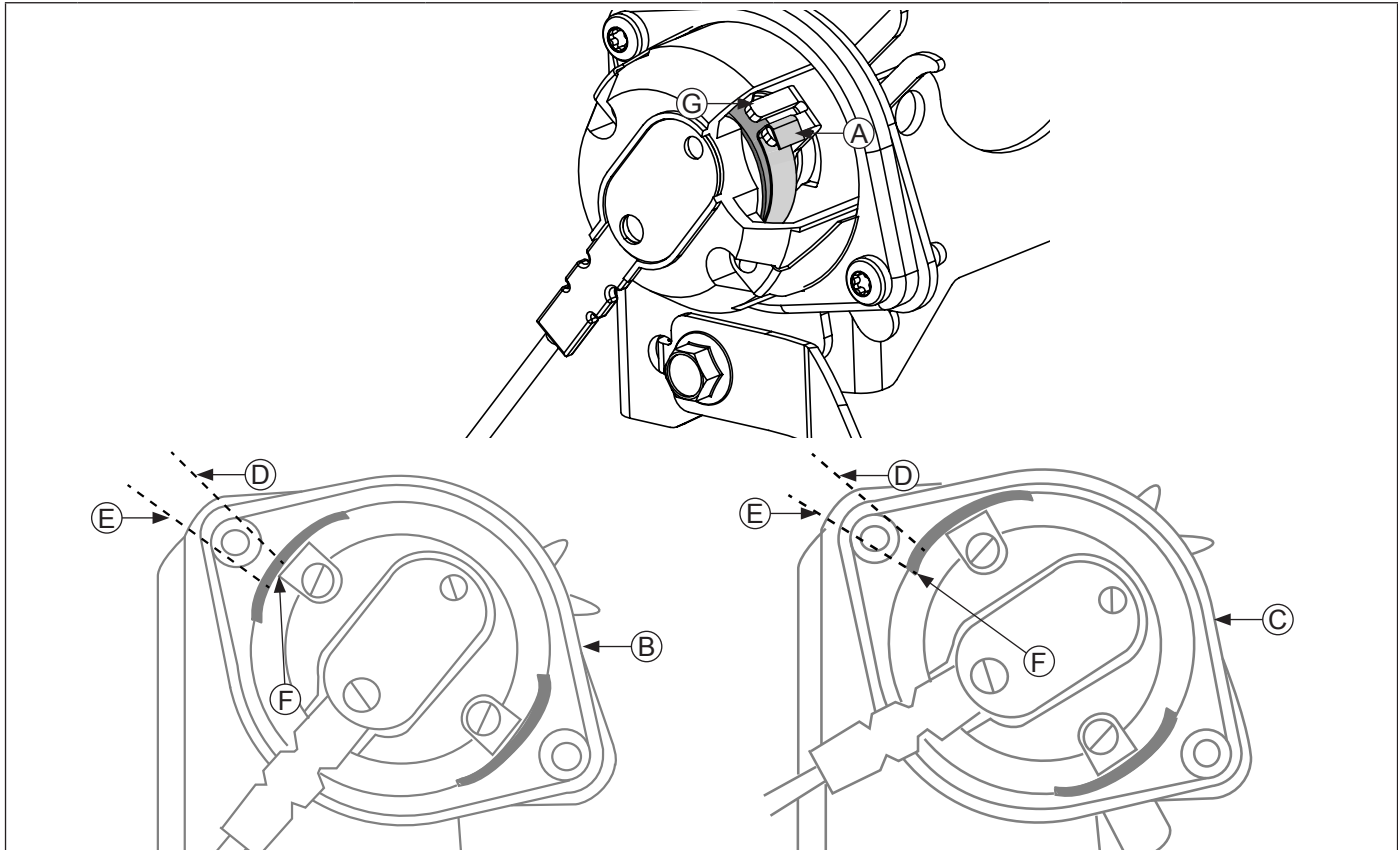

A	Spring Tab Must be Located in Lever Slot	B	Models KT725, KT735	C	Models KT740, KT745	D	High Position of Adjustment Range
E	Low Position of Adjustment Range	F	This Edge of Metallic Ground Strap Must Fall Within Adjustment Range	G	Lever Slot		

Adjustable Thermostat Reset

NOTE: Do not remove or loosen thermostat screws. Position is set at factory.

NOTE: Thermostat temperature must be at room temperature before testing.

If thermostat is loosened or removed, use following procedure to reset position.

1. Unplug thermostat wire.
2. Thermostat position should be set to low position of adjustment range (E).
3. Once thermostat position is set, engine must be started at idle with thermostat wire disconnected to test system function.
4. If engine runs correctly, no further adjustment is needed.
5. If engine speed does not increase to idle speed on start up, thermostat position must be adjusted by rotating housing clockwise in 1 mm increments and retested. Position should not exceed high adjustment range shown (D).
6. Plug in thermostat wire.

Dual Position Thermostat

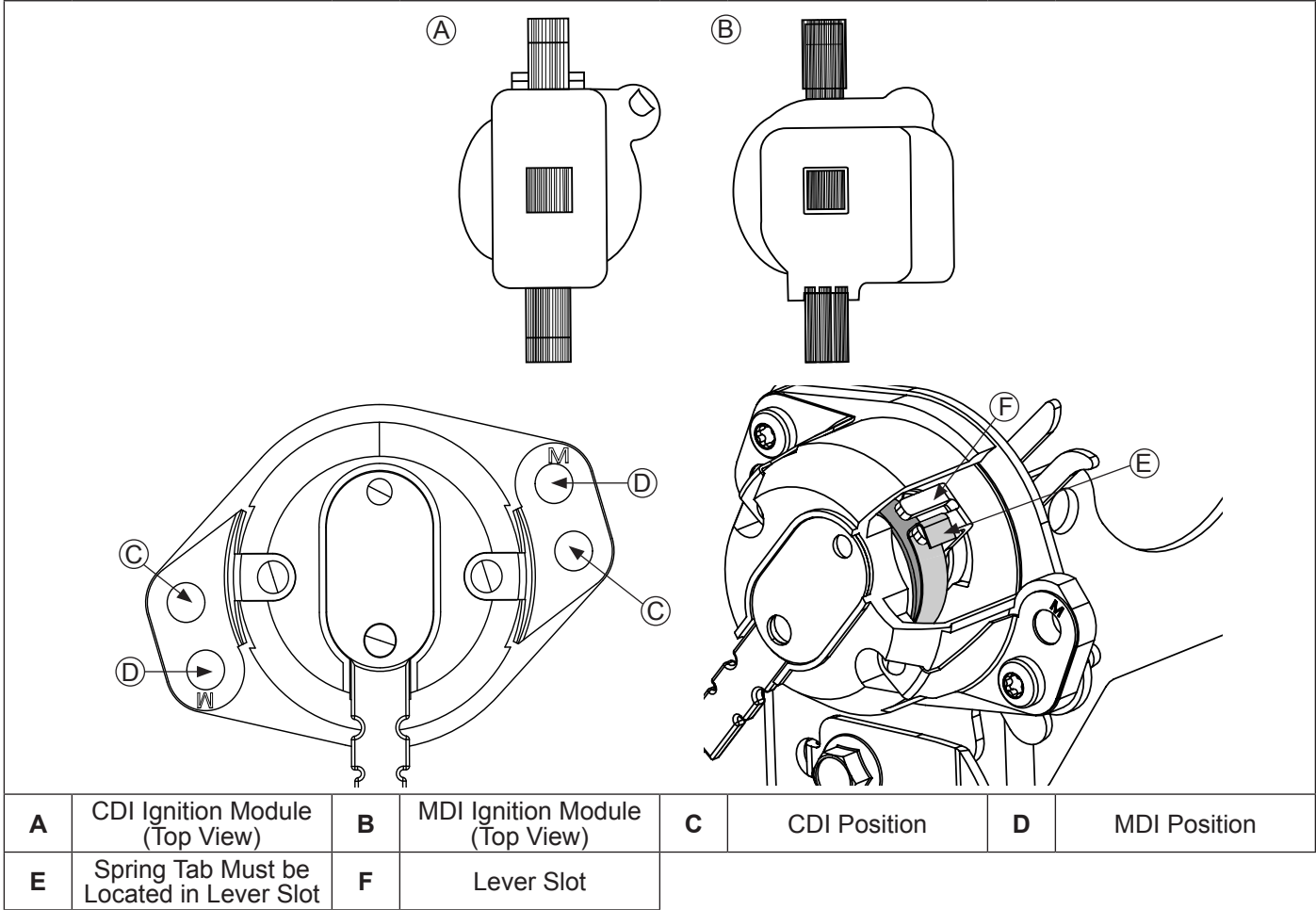

Dual Position Thermostat Installation

NOTE: Thermostat temperature must be at room temperature before testing.

- Determine operating position of thermostat. Thermostat position is determined by ignition system: Capacitive Discharge Ignition (CDI) or Magnetic Discharge Ignition (MDI).
For CDI systems secure thermostat in position (C).
For MDI systems secure thermostat in position (D).
- Install Smart-Choke™ bracket assembly with thermostat in proper position. Do not plug thermostat wire at this time.
- Engine must be started at idle with thermostat wire disconnected to test system function.
- If engine runs correctly, no further adjustment is needed.
- If engine speed does not increase to idle speed on start up, ensure spring tab (E) is engaged in lever slot (F) and thermostat is in proper position for ignition system of engine.
- Retest system function.
- Plug in thermostat wire.

Fuel System

Starting an Engine Equipped with Smart-Choke™

NOTE: Do not crank engine continuously for more than 10 seconds at a time. If engine does not start, allow a 60 second cool down period between starting attempts. Failure to follow these guidelines can burn out starter motor.

NOTE: If engine develops sufficient speed to disengage starter but does not keep running (a false start), engine rotation must be allowed to come to a complete stop before attempting to restart engine. If starter is engaged while flywheel is rotating, starter pinion and flywheel ring gear may clash, resulting in damage to starter.

1. Smart-Choke™ system will automatically control choke plate position for starting.
2. Make sure equipment is in neutral.
3. Activate starter switch. Release switch as soon as engine starts.
If starter does not turn engine over, shut starter off immediately. Do not make further attempts to start engine until condition is corrected. Do not jump start using another battery. See your Rehiko authorized dealer for trouble analysis.
4. For operation, after engine starts, move throttle and set desired engine operating speed.

Electronic Choke (eChoke™)

eChoke™ is an integrated control system that checks ambient and engine temperatures and monitors engine speed. This system is integrated through wiring to a master ignition/control module. Extended cranking (beyond 10 seconds) is not necessary, nor will it improve engine starting.

Calculations and unique software routines developed specifically for this Rehlko engine operate a carburetor choke lever through an assembly (bracket, linkage) to control a stepper motor. Power and ground are supplied to master control and ignition module (Cylinder 2) which provides a signal for stepper motor by way of a control harness that is routed through cylinder #2 baffle. An interconnection harness between two modules may exist (model dependent).

eChoke Components (Includes ignition due to integrated system)

- Master & slave ignition modules (with interface cables)
- Stepper motor
- Stepper motor bracket, linkage, and associated fasteners
- Wire harness (for power and ground)

eChoke™ Components

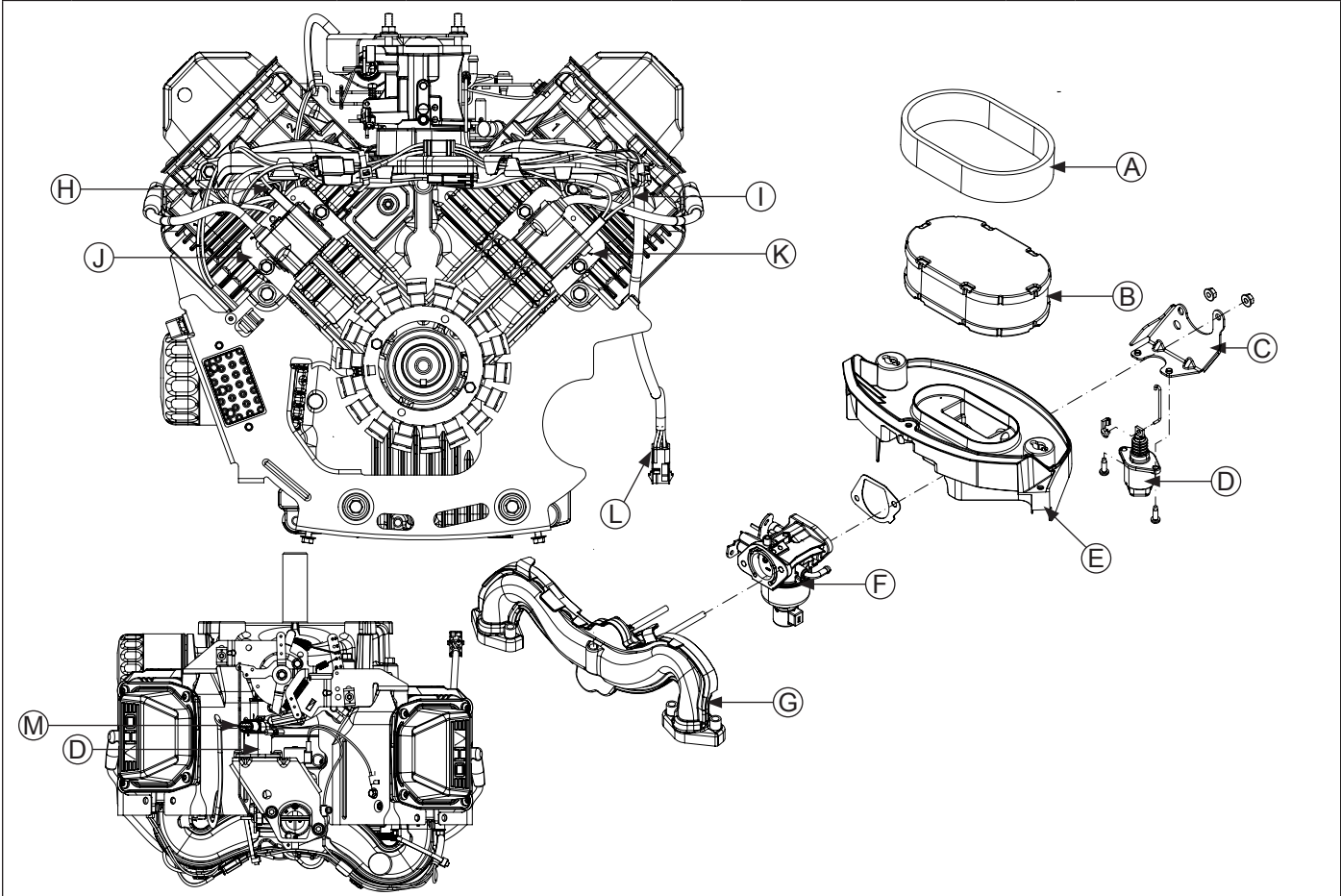

A	Precleaner	B	Paper Element	C	Stepper Motor Bracket and Hardware	D	Stepper Motor
E	Air Cleaner Base	F	Carburetor	G	Intake Manifold	H	Ignition Module Lead #2 Cylinder
I	Ignition Module Lead #1 Cylinder	J	Master Ignition Module	K	Slave Ignition Module	L	Red/Green Stripe to Constant Battery B+ Power
M	Master Controller Stepper Motor Harness/Connector						

Fuel System

eChoke™ System Standard Checks

NOTE: Procedures and troubleshooting may be easier to perform with engine cover removed. Refer to Disassembly/Inspection and Service and Reassembly procedure.

Use these procedures and guides to troubleshoot this system and its components. Perform a system reset prior to troubleshooting to verify problem still exists. Start with key switch in OFF position, operate through On-Off-On sequence and restart engine.

There are standard checks that should be made initially to help isolate possible problems:

1. Check choke assembly to ensure choke is properly connected. (Link connected to carburetor and stepper motor.)
2. Make sure link is located and connected properly.
3. Check for battery voltage (nonoperating), must be greater than 12.2 VDC open circuit.
(Low battery voltage may prevent proper operation of stepper motor.)
4. Check that constant power line (RED/GREEN stripe) connection is connected directly to battery B+.
5. Check for continuity through constant power line (possible fusible link failure).
6. Check for presence of constant (battery voltage) and switched power at harness. (Blower housing must be removed.)
7. Check that choke stepper motor is functioning. (Remove air cleaner cover and element. Operate key switch through On-Off-On sequence to inspect for any choke movement.)
8. If blink codes indicate a temperature read failure or RPM failure (see blink code info), then master controller/ignition is at fault and needs to be replaced.
9. If all standard checks are correct, proceed to Blink Codes.

Blink Codes

NOTE: Use of any other type of lamp, other than LED, could damage components.

eChoke™ system is equipped with an MIL connector that will allow connection of an LED lamp to show normal eChoke™ operation or specific error codes. This lead (white/red stripe) with a bullet connector next to stepper motor to which an LED (connected to lead and +12 volt power line) can be connected to review operation or look for error codes. Once a lamp is connected, operator can attempt to run through a normal start/crank/run/off sequence and monitor blink codes to determine if controller operation is correct.

Both normal operation and error code indication is listed in blink code table that follows. Note that code changes for each level of operation.

Table shows both normal operation and failure mode blinks codes. Normal operation blink codes will be displayed when no failure modes are detected during operation. These codes will only appear if there is no captured failure blink code. Failure mode blink codes are specific to integrated sensors associated with master controller/ignition module.

Operational blink sequence only occurs when routine associated to it is completed, until then LED will continue blinking to previously completed routine.

eChoke Diagnostics and Failure Mode Subroutines

- **DELAY**=LED OFF 2 seconds
- **ON**=LED ON 0.5 second
- **OFF**=LED OFF 0.5 second

Operational Tests

Test Step Number	Operation	Description of Operation	MIL Lamp Status	What is happening at eChoke™
1	Power Cycle	Remove and reconnect engine connector.	ON	Choke system will cycle to complete open and then complete close.
1A	Apply Power	Turn key from OFF to ON.	ON OFF ON DELAY	System activated, temperature read, waiting for engine to crank & start. Other MIL lamp sequence indicates failure mode 2B.
2A	Crank to Start	Turn key from RUN to CRANK.	ON OFF ON DELAY	Looking for starting engine speed. IF engine does not start, go to Failure Mode description 1B or 3B based on MIL lamp code.
3A	Choke Adjusting	Engine started, release Key to RUN position.	ON OFF ON OFF ON DELAY	eChoke™ moving to open position.
4A	Normal	Choke operation completed.	ON	eChoke™ stays in open position.
5A	Engine Shutdown	Turn Key from RUN to OFF.	ON DELAY	Once engine has come to a stop, choke will fully close.
6A	Power Saver Mode	System will switch to power saver mode after 30 minutes without engine speed reading.	OFF	System goes into power saver mode after 30 minutes of non use due to shut down by seat switch activation or when key switch moved to OFF. If activated by safety switch shutdown, operator MUST move to key OFF to reset sequence.

Fuel System

Failure Modes

<p>1B</p>	<p>Failure to Start</p>	<p>ON</p>	<p>Pause at RUN and attempt to CRANK engine. Limit cranking time to about 5 seconds. For first 4 failed crank attempts, choke will reposition at each attempt. After four (4) attempts, key OFF and make one final attempt to start. Check other components (spark plug, ignition, carburetor, fuel solenoid).</p>
<p>2B</p>	<p>Temperature Read Failure</p>	<p>ON OFF ON OFF ON OFF ON OFF ON DELAY</p>	<p>Faulty temperature sensor. System will keep choke closed at Key ON and ramp to open within 10 seconds of engine starting if this is root failure. Replace Master controller/ignition.</p>
<p>3B</p>	<p>RPM Read Failure</p>	<p>ON OFF ON OFF ON OFF ON DELAY</p>	<p>System defaults to this failure after 30 seconds of being in Key ON and no RPM. Choke will open to half position. Error clears if system reads RPM when engine is cranking. Replace Master controller/ignition.</p>

Troubleshooting eChoke™ Related Causes

Condition	Possible Cause	Conclusion
Engine starts hard, runs rough, or stalls at idle speed.	Choke not closing/moving a. Incorrect set up of stepper motor/link/bracket to carburetor. b. Broken or missing link.	Stepper motor/bracket/link assembly must allow for full travel, make sure link is located properly and connected.
	c. Loss of constant power or switched power. d. Loss of system ground. e. Fusible link is open. f. Stepper motor not functioning or shaft has fallen out of motor. g. Electronic component in Master ignition/control module is not functioning.	Bad wire harness connection, fusible link failure. Component failure in Master controller/ignition. Bad Master Controller harness.
Engine runs rich (indicated by black, sooty exhaust smoke, misfiring, loss of speed and power, governor hunting, or excessive throttle opening).	Choke partially closed during operation. a. Incorrect set up of stepper motor/link/bracket to carburetor. b. Broken or missing link.	Stepper motor/bracket/link assembly must allow for full travel, make sure link is located properly and connected.
	c. Loss of constant power or switched power. d. Loss of system ground. e. Fusible link is open. f. Stepper motor not functioning or shaft has fallen out of motor. g. Electronic component in Master ignition/control module is not functioning.	Bad wire harness connection, fusible link failure. Component failure in Master controller/ignition. Bad Master Controller harness.
Engine runs lean (indicated by misfiring, loss of speed and power, governor hunting, or excessive throttle opening).	Key integrated component in Master ignition/control module is not functioning.	Bad ignition module on specific cylinder.
	Incorrect set up of stepper motor/link/bracket to carburetor.	Stepper motor/bracket/link assembly must allow for full travel, make sure link is located properly and connected.

Fuel System

Starting an Engine Equipped with eChoke™

1. This eChoke™ system automatically controls choke plate position for starting.
2. Make sure equipment is in neutral and brake is engaged.
3. Activate starter switch. Release switch as soon as engine starts.
4. For operation, after engine starts, move throttle and set desired engine operating speed.
5. If engine does not start, remove air cleaner cover, and air cleaner from air cleaner base.
6. Confirm connection of stepper motor assembly to carburetor.
7. With key switch set to OFF, choke plate should nearly fully closed, stepper motor for eChoke should be near full extension (expanded bellows).
8. With engine/ambient temperature above 40°F (4°C), turn key switch from OFF to RUN. There should be a noticeable movement of choke plate.
9. If no movement:
 - a. Shut off key switch and test for full travel of actuator by disconnection and reconnection of constant power (RED/GREEN STRIPE) at engine connector.
 - b. If there is still no movement, separate tests to validate battery voltage and power and ground connection to master controller need to be performed.
10. If movement is noted, attempt to crank and start engine. (Do not exceed 10 seconds of cranking.)
11. If engine does not start:

Release key to RUN position, (do not shut OFF), pause, movement of choke should be noted.

Repeat from beginning of step 10 (this routine can be attempted 4 times). Choke should be fully relieved after final attempt. If eChoke™ assembly moves choke plate through each attempt, but engine still did not start, problem is not associated with eChoke™, but is rather another system or component issue.

Governor/Throttle Control Connections

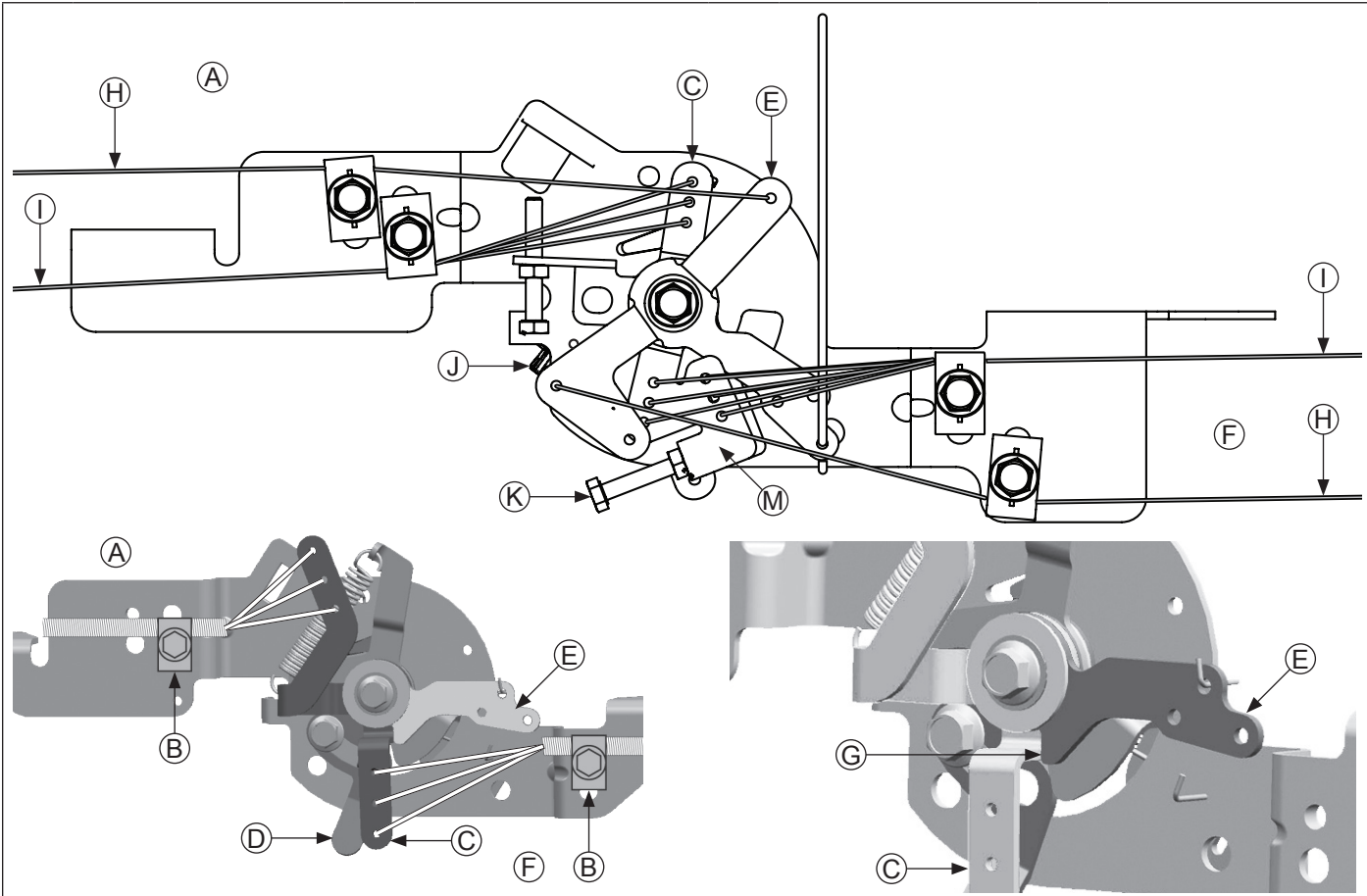

A	Left Side Pull	B	Cable Clamp	C	Speed Control Lever	D	Speed Setting Lever
E	Choke Lever	F	Right Side Pull	G	Contact Point	H	Choke Control Cable
I	Throttle Control Cable	J	Dual Control High Speed Lever Stop Screw (Do Not Remove)	K	High Speed Adjusting Screw	L	Choke Linkage
M	High Speed Control Lever						

Fuel System

UNITIZED THROTTLE AND CHOKE CONTROL

Some engines are equipped with a unitized throttle and choke control. This assembly controls choke and engine speed with a single lever. Engines with a unitized throttle and choke control will have either a left side pull or a right side pull.

Throttle Cable Adjustment

NOTE: Choke is placed ON by moving throttle control slightly past fast position. If throttle control does not have a designated choke ON position, be sure to leave sufficient throttle control travel past fast position. This will enable choke to be placed ON.

1. Loosen control cable clamp.
2. Place throttle control lever of equipment into fast or high speed position.
3. Pull on outer shield of throttle control cable until speed control lever rotates and makes contact with choke lever. Tighten cable clamp securely.

Starting an Engine Equipped with Unitized Throttle and Choke Control

NOTE: Do not crank engine continuously for more than 10 seconds at a time. If engine does not start, allow a 60 second cool down period between starting attempts. Failure to follow these guidelines can burn out starter motor.

NOTE: If engine develops sufficient speed to disengage starter but does not keep running (a false start), engine rotation must be allowed to come to a complete stop before attempting to restart engine. If starter is engaged while flywheel is rotating, starter pinion and flywheel ring gear may clash, resulting in damage to starter.

1. For a Cold or Warm Engine – Place throttle/choke control into fast/choke ON position. This will also place choke into ON position.
2. Make sure equipment is in neutral.
3. Activate starter switch. Release switch as soon as engine starts.

If starter does not turn engine over, shut starter off immediately. Do not make further attempts to start engine until condition is corrected. Do not jump start using another battery. See your Rehiko authorized dealer for trouble analysis.

4. For Operation – After engine starts, move throttle/choke control from fast/choke ON position and set desired engine operating speed (between slow and fast position).

GOVERNOR

Governed speed setting is determined by position of throttle control. It can be variable or constant, depending on engine application.

Governor is designed to hold engine speed constant under changing load conditions. Most engines are equipped with a centrifugal flyweight mechanical governor. Governor gear/flyweight mechanism of mechanical governor is mounted inside oil pan and is driven off gear on camshaft.

Governor Components

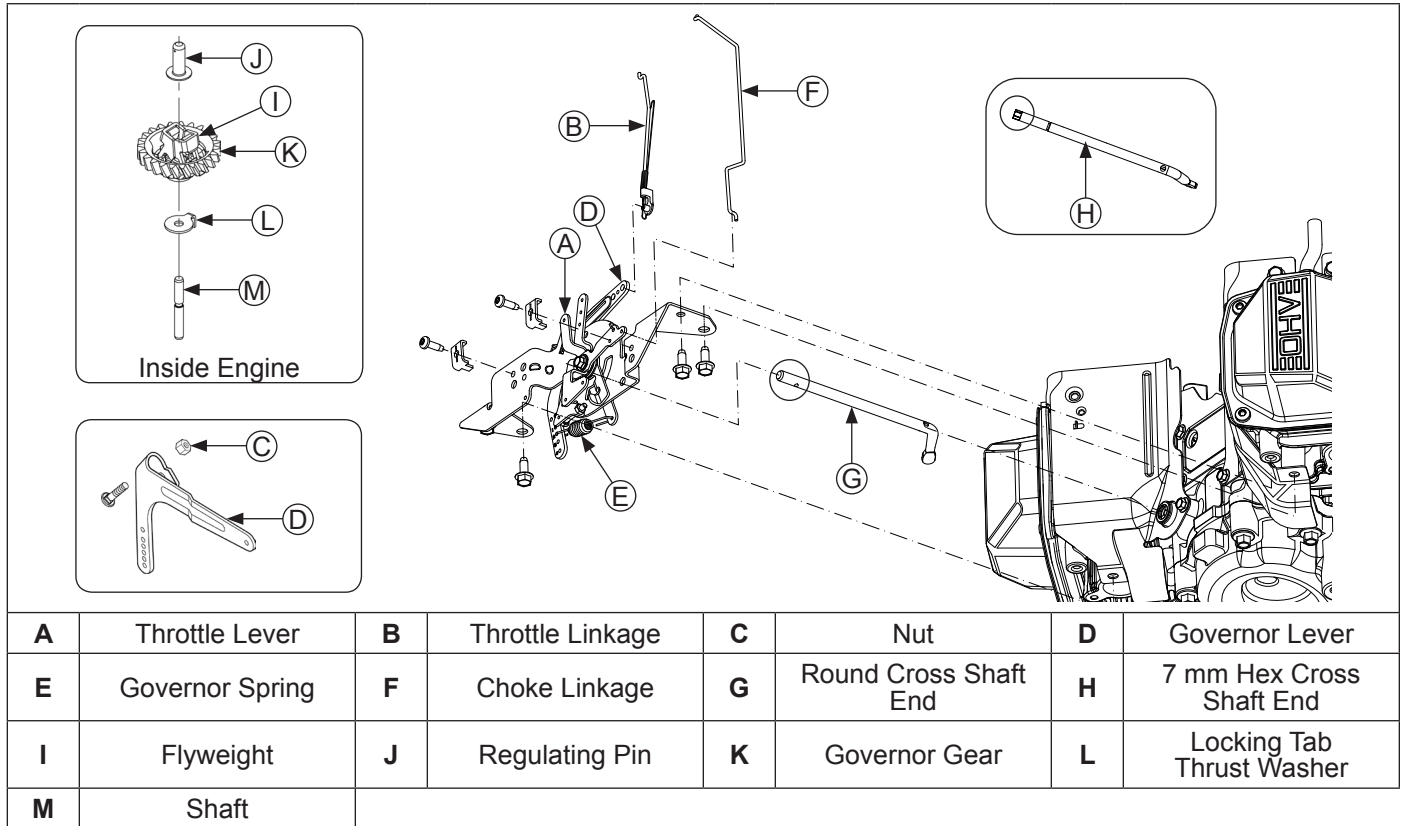

This governor design works as follows:

- Centrifugal force acting on rotating governor gear assembly causes flyweights to move outward as speed increases. Governor spring tension moves them inward as speed decreases.
- As flyweights move outward, they cause regulating pin to move outward.
- Regulating pin contacts tab on cross shaft causing shaft to rotate.
- One end of cross shaft protrudes through crankcase. Rotating action of cross shaft is transmitted to throttle lever of carburetor through external throttle linkage.
- When engine is at rest, and throttle is in fast position, tension of governor spring holds throttle plate open. When engine is operating, governor gear assembly is rotating. Force applied by regulating pin against cross shaft tends to close throttle plate. Governor spring tension and force applied by regulating pin balance each other during operation, to maintain engine speed.
- When load is applied and engine speed and governor gear speed decreases, governor spring tension moves governor arm to open throttle plate wider. This allows more fuel into engine, increasing engine speed. As speed reaches governed setting, governor spring tension and force applied by regulating pin will again offset each other to hold a steady engine speed.

Governor Adjustments

NOTE: Do not tamper with governor setting. Overspeed is hazardous and could cause personal injury.

Initial Adjustment Procedure

Make this adjustment whenever governor arm is loosened or removed from cross shaft. To ensure proper adjustment, make sure throttle linkage is connected to both governor arm and throttle lever on carburetor. Adjust as follows:

1. Make sure throttle linkage is connected to governor arm and throttle lever on carburetor.
2. Loosen nut holding governor lever to cross shaft.
3. Move governor lever toward carburetor as far as it will go (wide open throttle) and hold in this position.
4. **Round Cross Shaft End:** Insert a long thin rod or tool into hole on cross shaft and rotate shaft counterclockwise (viewed from end) as far as it will turn, then torque nut to 6.8 N·m (60 in. lb.).

7 mm Hex Cross Shaft End: Use 7 mm hex socket on end of cross shaft and rotate shaft counterclockwise (viewed from end) as far as it will turn, then torque nut to 6.8 N·m (60 in. lb.).

Lubrication System

This engine uses a combination pressure/splash lubrication system, delivering oil under pressure to crankshaft, connecting rod and main bearing surfaces. Other component areas are splash lubricated.

A high-efficiency gerotor oil pump maintains high oil flow and oil pressure, even at low speeds and high operating temperatures. A pressure relief valve limits maximum pressure of system. Oil pan must be removed to service oil pickup and oil pump.

Lubrication Components

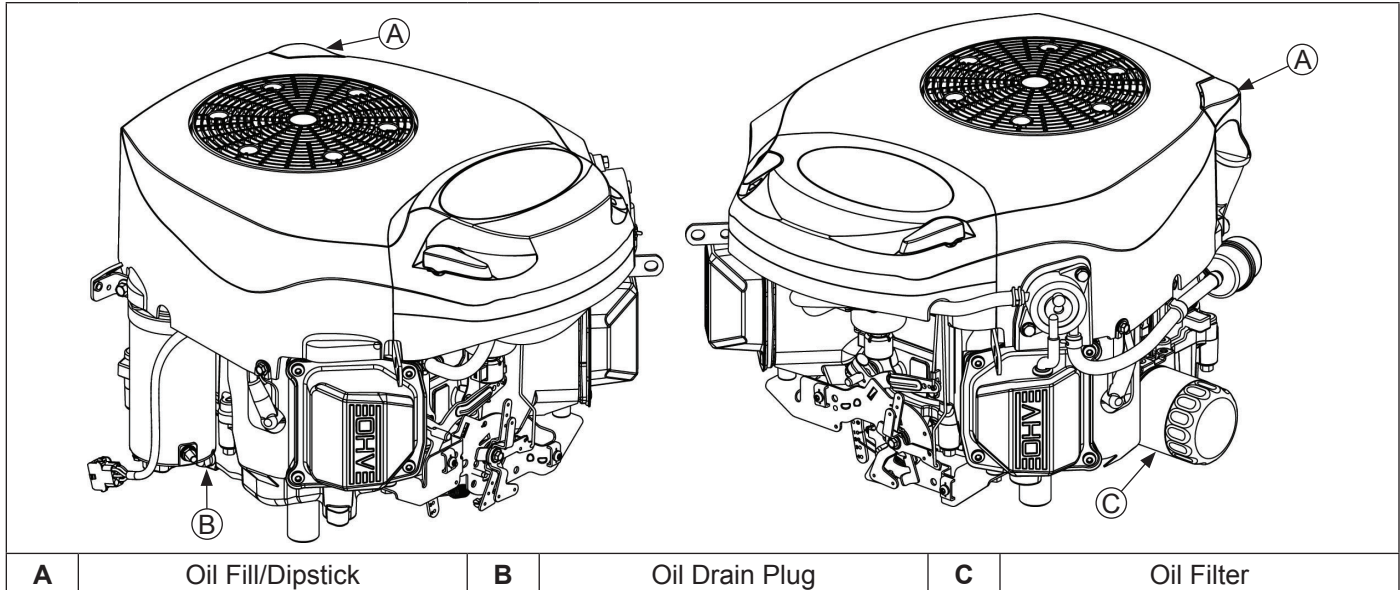

OIL RECOMMENDATIONS

Refer to Maintenance.

CHECK OIL LEVEL

NOTE: To prevent extensive engine wear or damage, never run engine with oil level below or above operating range indicator on dipstick.

Ensure engine is cool. Clean oil fill/dipstick areas of any debris.

1. Remove dipstick; wipe oil off.
2. Reinsert dipstick into tube; press completely down.
3. Remove dipstick; check oil level. Level should be at top of indicator on dipstick.
4. If oil is low on indicator, add oil up to top of indicator mark.
5. Reinstall and secure dipstick.

CHANGE OIL AND FILTER

Change oil while engine is warm.

1. Clean area around oil fill/dipstick. Remove drain plug and oil fill/dipstick. Allow oil to drain completely.
2. Clean area around oil filter. Place a container under filter to catch any oil and remove filter. Wipe off mounting surface. Reinstall drain plug. Torque to 13.6 N·m (10 ft. lb.).
3. Place new filter in shallow pan with open end up. Fill with new oil until oil reaches bottom of threads. Allow 2 minutes for oil to be absorbed by filter material.
4. Apply a thin film of clean oil to rubber gasket on new filter.
5. Refer to instructions on oil filter for proper installation.
6. Fill crankcase with new oil. Level should be at top of indicator on dipstick.
7. Reinstall oil fill/dipstick and tighten securely.
8. Start engine; check for oil leaks. Stop engine; correct leaks. Recheck oil level.
9. Dispose of used oil and filter in accordance with local ordinances.

OIL SENTRY™ (if equipped)

NOTE: Make sure oil level is checked before each use, and is maintained up to FULL or F mark on dipstick. This includes engines equipped with Oil Sentry™.

This switch is designed to prevent engine from starting in a low oil or no oil condition. Oil Sentry™ may not shut down a running engine before damage occurs. In some applications this switch may activate a warning signal. Read your equipment manuals for more information.

Oil Sentry™ pressure switch is installed in oil filter adapter. Pressure switch is designed to break contact as oil pressure increases above 3-5 psi, and make contact as oil pressure decreases below 3-5 psi.

On stationary or unattended applications (pumps, generators, etc.), pressure switch can be used to ground ignition module to stop engine. On vehicular applications (lawn tractors, mowers, etc.) pressure switch can only be used to activate a low oil warning light or signal.

Installation

1. Apply pipe sealant with Teflon® (Loctite® PST® 592™ Thread Sealant or equivalent) to threads of switch.
2. Install switch into tapped hole in oil filter adapter.
3. Torque switch to 4.5 N·m (40 in. lb.).

Testing

Compressed air, a pressure regulator, pressure gauge, and a continuity tester are required to test switch.

1. Connect continuity tester across blade terminal and metal case of switch. With 0 psi pressure applied to switch, tester should indicate continuity (switch closed).
2. Gradually increase pressure to switch. As pressure increases through range of 2-5 psi tester should indicate a change to no continuity (switch open). Switch should remain open as pressure is increased to 90 psi maximum.
3. Gradually decrease pressure through range of 2-5 psi. Tester should indicate a change to continuity (switch closed) down to 0 psi.
4. Replace switch if it does not operate as specified.

Electrical System

SPARK PLUGS



CAUTION

Electrical Shock can cause injury.
Do not touch wires while engine is running.

Spark Plug Component and Details

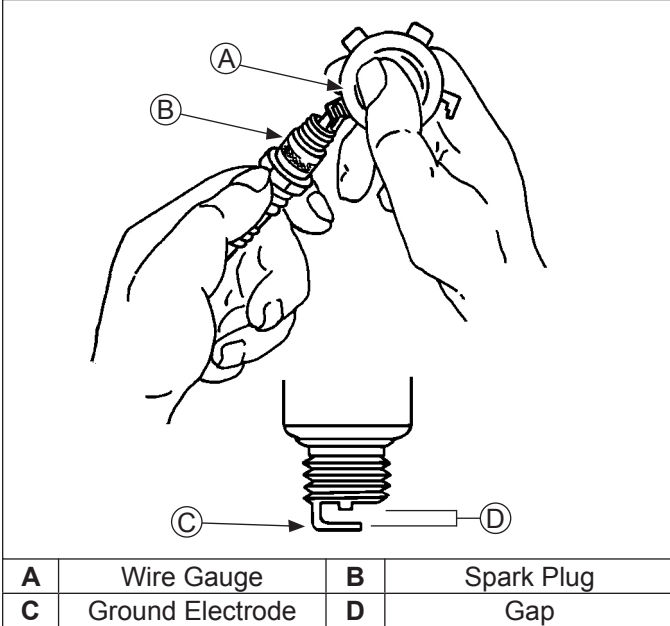

NOTE: Do not clean spark plug in a machine using abrasive grit. Some grit could remain in spark plug and enter engine causing extensive wear and damage.

Engine misfire or starting problems are often caused by a spark plug that has improper gap or is in poor condition.

Engine is equipped with following spark plugs:

Gap	0.76 mm (0.030 in.)
Thread Size	14 mm
Reach	19.1 mm (3/4 in.)
Hex Size	15.9 mm (5/8 in.)

Refer to Maintenance for Repairs/Service Parts.

Service

Clean out spark plug recess. Remove plug and replace.

1. Check gap using wire feeler gauge. Adjust gap to 0.76 mm (0.030 in.).
2. Install plug into cylinder head.
3. Torque plug to 27 N·m (20 ft. lb.).

Inspection

Inspect each spark plug as it is removed from cylinder head. Deposits on tip are an indication of general condition of piston rings, valves, and carburetor.

Normal and fouled plugs are shown in following photos:

Normal

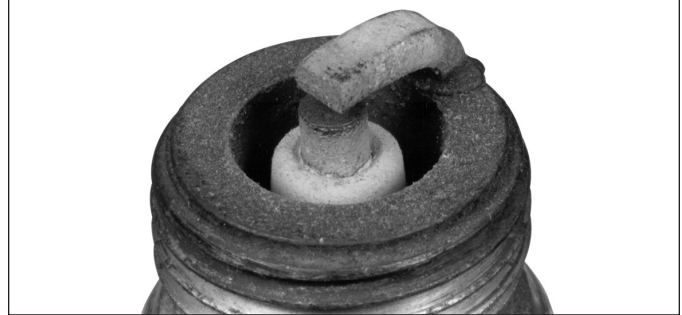

Plug taken from an engine operating under normal conditions will have light tan or gray colored deposits. If center electrode is not worn, plug can be set to proper gap and reused.

Worn



On a worn plug, center electrode will be rounded and gap will be greater than specified gap. Replace a worn spark plug immediately.

Wet Fouled



A wet plug is caused by excess fuel or oil in combustion chamber. Excess fuel could be caused by a restricted air cleaner, a carburetor problem, or operating engine with too much choke. Oil in combustion chamber is usually caused by a restricted air cleaner, a breather problem, worn piston rings, or valve guides.

Carbon Fouled



Soft, sooty, black deposits indicate incomplete combustion caused by a restricted air cleaner, over rich carburetion, weak ignition, or poor compression.

Overheated



Chalky, white deposits indicate very high combustion temperatures. This condition is usually accompanied by excessive gap erosion. Lean carburetor settings, an intake air leak, or incorrect spark timing are normal causes for high combustion temperatures.

BATTERY

A 12-volt battery with 400 cold cranking amps (cca) is generally recommended for starting in all conditions. A smaller capacity battery is often sufficient if an application is started only in warmer temperatures. Refer to following table for minimum capacities based on anticipated ambient temperatures. Actual cold cranking requirement depends on engine size, application, and starting temperatures. Cranking requirements increase as temperatures decrease and battery capacity shrinks. Refer to equipment's operating instructions for specific battery requirements.

Battery Size Recommendations

Temperature	Battery Required
Above 32°F (0°C)	200 cca minimum
0°F to 32°F (-18°C to 0°C)	250 cca minimum
-5°F to 0°F (-21°C to -18°C)	300 cca minimum
-10°F (-23°C) or below	400 cca minimum

If battery charge is insufficient to turn over engine, recharge battery.

Battery Maintenance

Regular maintenance is necessary to prolong battery life.

Battery Test

To test battery, follow manufacturer's instructions.

ELECTRONIC IGNITION SYSTEMS

All ignition systems are designed to be trouble free for life of engine. Other than periodically checking/replacing spark plugs, no maintenance or timing adjustments are necessary or possible. Mechanical systems do occasionally fail or break down. Refer to Troubleshooting to determine root of a reported problem.

Reported ignition problems are most often due to poor connections. Before beginning test procedure, check all external wiring. Be certain all ignition-related wires are connected, including spark plug leads. Be certain all terminal connections fit snugly. Make sure ignition switch is in run position.

Electrical System

Ignition Systems

These systems use a capacitive discharge (CD) coil. With CDI fixed timing, ignition timing and spark remains constant regardless of engine speed. Timing of spark is controlled by location of flywheel magnet group as referenced to engine TDC. MDI adjustable timing uses a digital microprocessor which is located in ignition modules. Ignition timing varies depending upon engine speed with this system.

A typical fixed ignition system consists of:

- 1 magnet assembly which is permanently affixed to flywheel.
- 2 electronic capacitive-discharge or magnetic discharge ignition modules which mount on engine crankcase.
- 1 kill switch (or key switch) which grounds modules to stop engine.
- 2 spark plugs.

Wiring Diagram-Electronic Ignition System Diagram

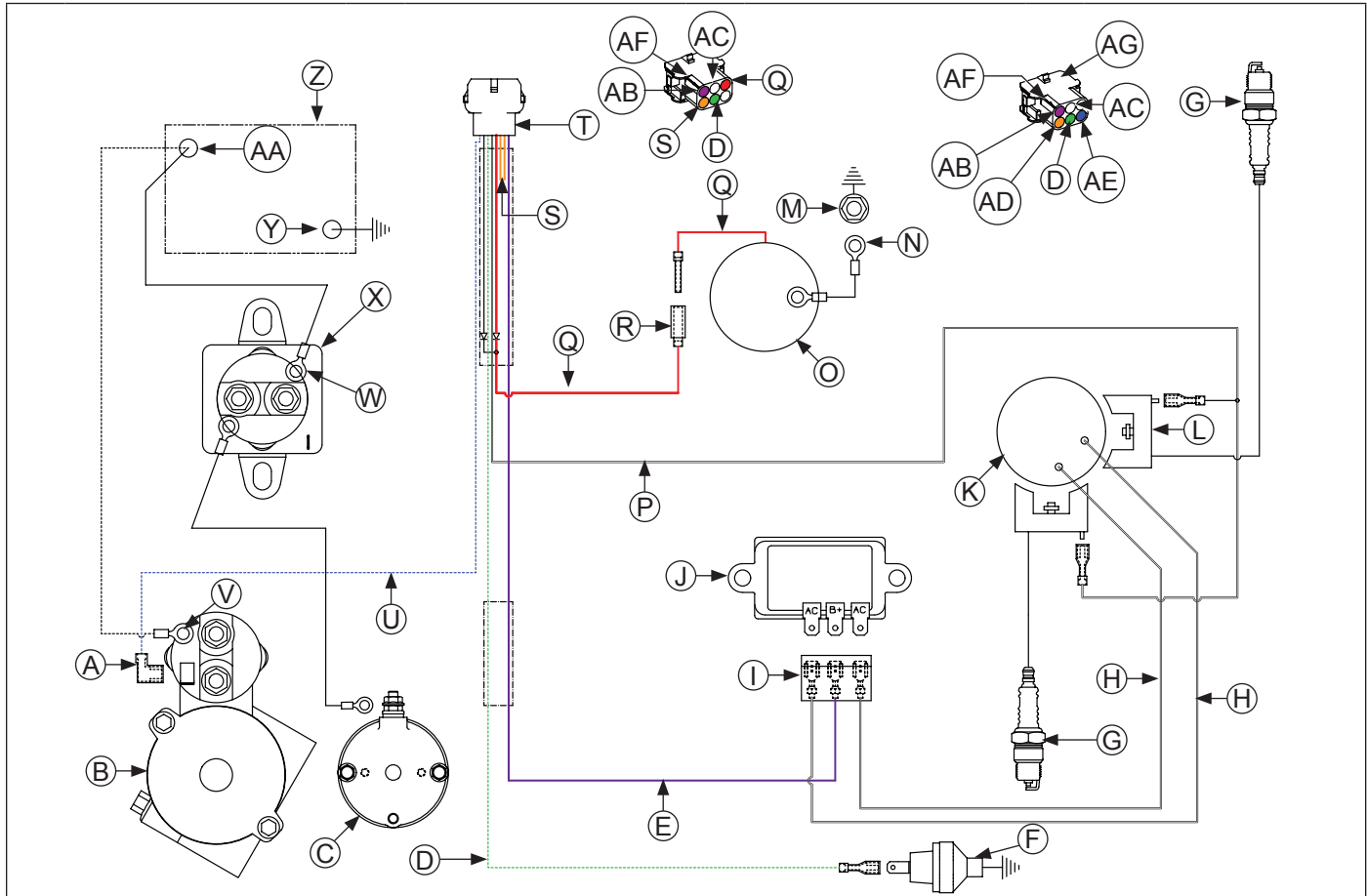

A	Starter Solenoid Tang	B	Solenoid Shift Starter Assembly	C	Inertia Driver Starter Assembly	D	Green
E	Violet (Charging)	F	Oil Sentry™ (Optional)	G	Spark Plug(s)	H	White (AC Charging Leads)
I	Rectifier-Regulator Connector	J	Rectifier-Regulator	K	Flywheel Stator Assembly	L	Ignition Module(s)
M	Intake Manifold Screw	N	Ground	O	Carburetor	P	White (Ignition Kill)
Q	Red	R	Solenoid Lead	S	Orange	T	Connector
U	Blue	V	Starter Solenoid Stud	W	Relay Stud	X	Relay Cranking (Customer Supplied)
Y	Battery Negative	Z	Battery	AA	Battery Positive	AB	Violet (shown) or Orange
AC	White	AD	Orange (shown) or Red	AE	Blue (shown) or Red	AF	Polarity Rib
AG	Solenoid Shift Starter Assembly (Optional)						

Wiring Diagram-Electronic Ignition System with Original Design Smart-Choke™ System

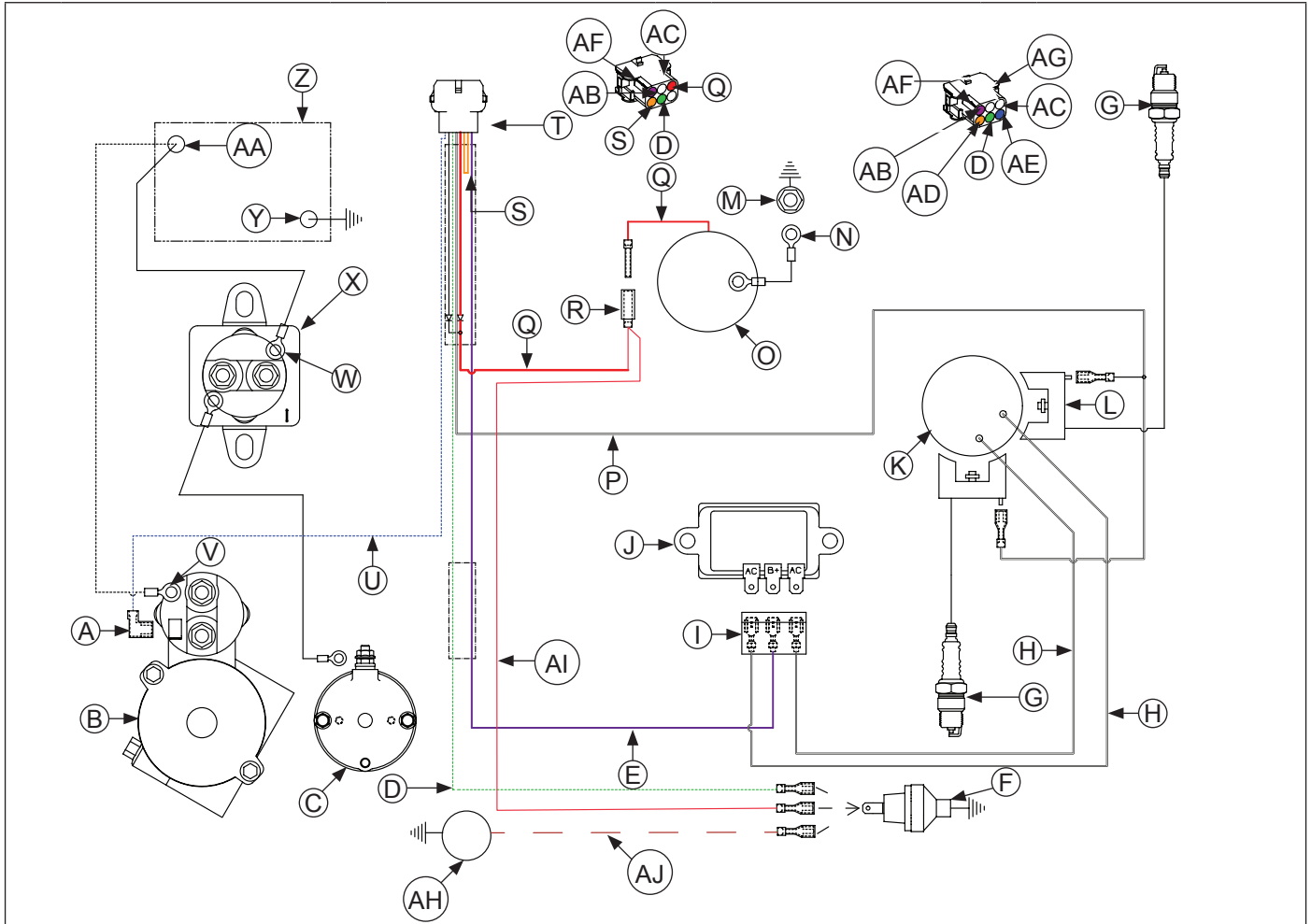

A	Starter Solenoid Tang	B	Solenoid Shift Starter Assembly	C	Inertia Driver Starter Assembly	D	Green
E	Violet (Charging)	F	Oil Sentry™ (3-Terminal Switch)	G	Spark Plug(s)	H	White (AC Charging Leads)
I	Rectifier-Regulator Connector	J	Rectifier-Regulator	K	Flywheel Stator Assembly	L	Ignition Module(s)
M	Intake Manifold Screw	N	Ground	O	Carburetor	P	White (Ignition Kill)
Q	Red	R	Solenoid Lead	S	Orange	T	Connector
U	Blue	V	Starter Solenoid Stud	W	Relay Stud	X	Relay Cranking (Customer Supplied)
Y	Battery Negative	Z	Battery	AA	Battery Positive	AB	Violet (shown) or Orange
AC	White	AD	Orange (shown) or Red	AE	Blue (shown) or Red	AF	Polarity Rib
AG	Solenoid Shift Starter Assembly (Optional)	AH	Thermostat Assembly	AI	Red	AJ	Red w/Black Line

Electrical System

Wiring Diagram-Electronic Ignition System with Updated Design Smart-Choke™ System

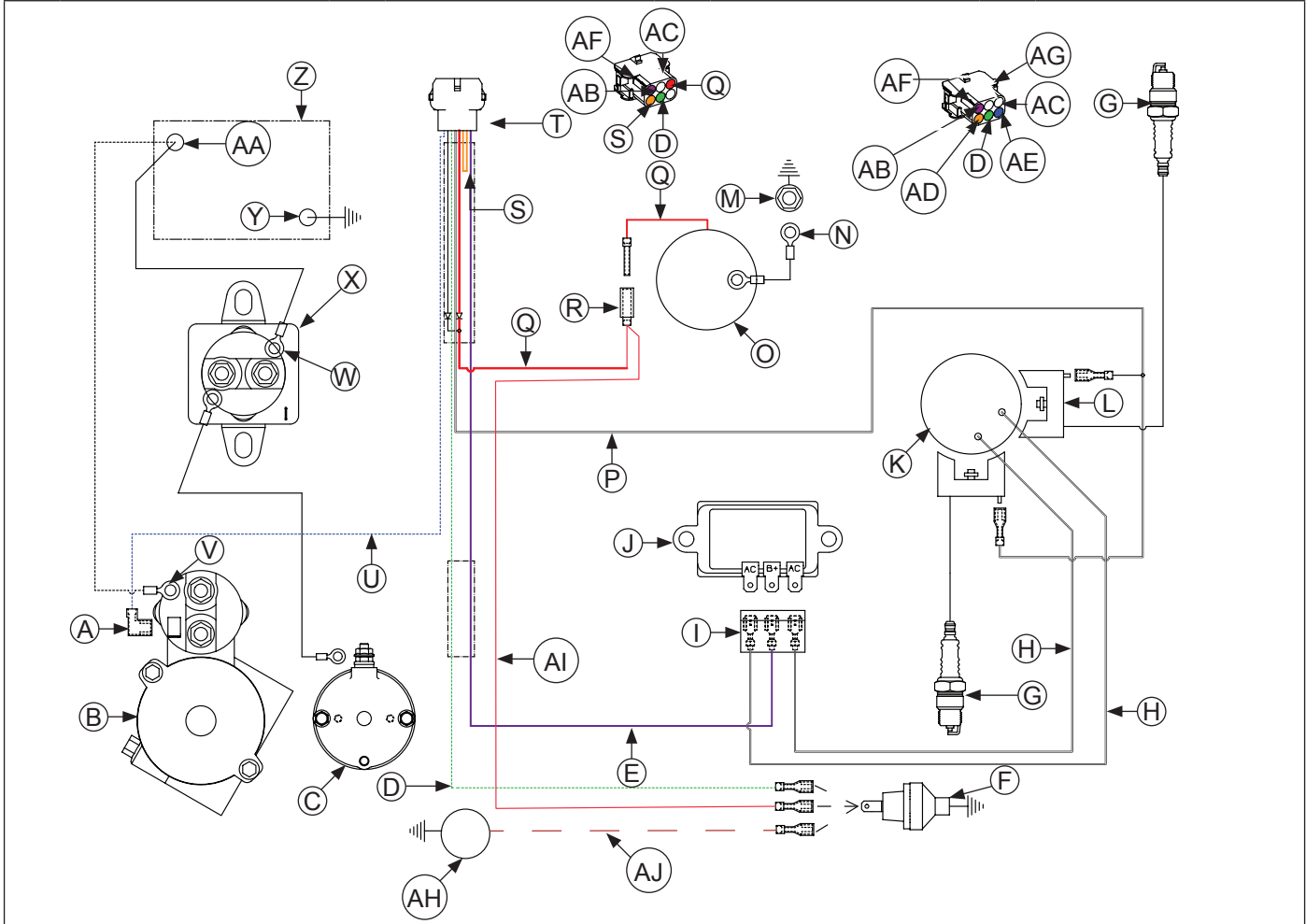

A	Starter Solenoid Tang	B	Solenoid Shift Starter Assembly	C	Inertia Driver Starter Assembly	D	Green
E	Violet (Charging)	F	Oil Sentry™ (Optional 1-Terminal Switch)	G	Spark Plug(s)	H	White (AC Charging Leads)
I	Rectifier-Regulator Connector	J	Rectifier-Regulator	K	Flywheel Stator Assembly	L	Ignition Module(s)
M	Intake Manifold Screw	N	Ground	O	Carburetor	P	White (Ignition Kill)
Q	Red	R	Solenoid Lead	S	Orange	T	Connector
U	Blue	V	Starter Solenoid Stud	W	Relay Stud	X	Relay Cranking (Customer Supplied)
Y	Battery Negative	Z	Battery	AA	Battery Positive	AB	Violet (shown) or Orange
AC	White	AD	Orange (shown) or Red	AE	Blue (shown) or Red	AF	Polarity Rib
AG	Solenoid Shift Starter Assembly (Optional)	AH	Thermostat Assembly	AI	Fuse	AJ	Red w/Black Line

*For engines with eChoke™, refer to component illustrations in Fuel Section of this manual.

Electronic Ignition Systems Tests

NOTE: Ignition tester must be used to test ignition on these engines. Use of any other tester can result in inaccurate findings. Battery on unit must be fully charged and properly connected before performing tests (a battery that is hooked up or charged backward will crank engine but it won't have spark). Be certain drive is in neutral and all external loads are disconnected.

Test Ignition Systems

NOTE: If engine starts or runs during testing, you may need to ground kill lead to shut it down. Because you have interrupted kill circuit, it may not stop using switch.

Isolate and verify trouble is within engine.

1. Locate connectors where wiring harnesses from engine and equipment are joined. Separate connectors and remove white kill lead from engine connector. Rejoin connectors and position or insulate kill lead terminal so it cannot touch ground. Try to start engine to verify whether reported problem is still present.

Condition	Possible Cause	Conclusion
Problem goes away.	Electrical System	Check key switch, wires, connections, safety interlocks, etc.
Problem persists.	Ignition or Electrical System	Leave kill lead isolated until all testing is completed. Identify white kill lead of engine wiring harness connector. Establish a connection to a known good ground location. Engine should kill completely. If not or only one cylinder is affected, test ignition modules.

Test for Spark

NOTE: If 2 testers are available, testing can be performed simultaneously for both cylinders. However, if only 1 tester is available, 2 individual tests must be performed. Side not being tested must have spark plug lead connected or grounded. Do not crank engine or perform tests with 1 spark plug lead disconnected and not grounded, or permanent system damage may occur.

1. With engine stopped, disconnect 1 spark plug lead. Connect spark plug lead to post terminal of spark tester and attach tester clip to a good engine ground.
2. Crank engine over, establishing a minimum of 550-600 RPM, and observe tester(s) for spark.
3. Repeat spark test on opposite cylinder if cylinders are being tested individually.

Condition	Possible Cause	Conclusion
One side is not firing.	Wiring and Connections	Check all wiring, connections, and terminals on that side. If wiring is okay, replace ignition module and retest for spark.
Tester shows spark but engine misses or won't run on that cylinder.	Spark Plug(s)	Try new spark plug(s).
Neither side is firing.	Ignition Switch	Recheck position of ignition switch and check for shorted kill lead.
Both cylinders have good spark but engine runs poorly or existing plug condition is questionable.	Spark Plug(s)	Install new spark plug(s) and retest engine performance.
1 cylinder has good spark and other cylinder has no or intermittent spark.	Ignition	Test ignition modules and connections.

Electrical System

BATTERY CHARGING SYSTEM

NOTE: Observe following guidelines to avoid damage to electrical system and components:

- Make sure battery polarity is correct. A negative (–) ground system is used.
- Disconnect rectifier-regulator plug and/or wiring harness plug before doing any electric welding on equipment powered by engine. Disconnect all other electrical accessories in common ground with engine.
- Prevent stator (AC) leads from touching or shorting while engine is running. This could damage stator.

Most engines are equipped with a 12/15 amp regulated charging system. Some have a 25 amp regulated charging system.

12/15/25 Amp Regulated Charging System

Stator

Stator is mounted on crankcase behind flywheel. Follow procedures in Disassembly and Reassembly if stator replacement is necessary.

Rectifier-Regulator

NOTE: When installing rectifier-regulator, take note of terminal positions and install plug correctly.

NOTE: Disconnect all electrical connections attached to rectifier-regulator. Testing may be performed with rectifier-regulator mounted or loose. Repeat applicable test procedure 2 or 3 times to determine condition of part.

Rectifier-regulator is mounted on backing shroud assembly. To replace it, disconnect plug, remove mounting screws, and ground lead.

Testing rectifier-regulator may be performed as follows, using appropriate rectifier-regulator tester.

To test 25 amp rectifier-regulators:

1. Connect single lead adapter in between B+ (center) terminal of rectifier-regulator being tested and squared single end of tandem adapter lead.
2. Connect tester ground lead (with spring clamp) to body of rectifier-regulator.
3. Connect red lead and 1 black lead to terminals on open end of tandem adapter lead (connections are not location specific).
4. Connect remaining black lead from tester to 1 outer AC terminal on rectifier-regulator.
5. Plug tester into proper AC outlet/power for tester being used. Turn on power switch. POWER light should be illuminated and 1 of 4 status lights may be on as well. This does not represent condition of part.
6. Press TEST button until a click is heard and then release. Momentarily 1 of 4 lights will illuminate indicating partial condition of part.

To test 12/15 amp rectifier-regulators:

1. Connect tester ground lead (with spring clamp) to body of rectifier-regulator being tested.
2. Connect tester red lead to B+ terminal of rectifier-regulator and 2 black tester leads to 2 AC terminals.
3. Plug tester into proper AC outlet/power for tester being used. Turn on power switch. POWER light should be illuminated and 1 of 4 status lights may be on as well. This does not represent condition of part.
4. Press TEST button until a click is heard and then release. Momentarily 1 of 4 status lights will illuminate indicating condition of part.

Condition	Conclusion	
	25 amp	12/15 amp
OK (green) light comes on and stays steady.	Disconnect tester black lead attached to 1 AC terminal and reconnect it to other AC terminal. Repeat test. If OK (green) light comes on again, part is good and may be used.	Part is good and may be used.
NOTE: A flashing LOW light can also occur as a result of an inadequate ground lead connection. Make certain connection location is clean and clamp is secure. Other lights come on.	Rectifier-regulator is faulty and should not be used.	

12/15/25 Amp Battery Charging Systems

NOTE: Always zero ohmmeter on each scale before testing to ensure accurate readings. Voltage tests should be made with engine running at 3600 RPM with no load. Battery must be good and fully charged.

When problems occur in keeping battery charged or battery charges at high rate, charging system or battery might be causing problems.

To test charging system for no charge to battery:

1. Insert an ammeter in B+ lead from rectifier-regulator. With engine running at 3600 RPM and B+ (at terminal on rectifier-regulator) to ground using a DC voltmeter.

If voltage is 13.8 volts or more, place a minimum load of 5 amps (turn on lights if 60 watts or more, or place a 2.5 ohm, 100 watt resistor across battery terminals) on battery to reduce voltage. Observe ammeter.

Condition	Conclusion
Charge rate increases when load is applied.	Charging system is OK and battery was fully charged.
Charge rate does not increase when load is applied.	Test stator and rectifier-regulator (steps 2 and 3).

2. Remove connector from rectifier-regulator. With engine running at 3600 RPM, measure AC voltage across stator leads using an AC voltmeter.

Condition	Conclusion
Voltage is 28 volts or more.	Stator is OK. Rectifier-regulator is faulty; replace.
Voltage is less than 28 volts.	Stator is faulty; replace. Test stator further using an ohmmeter (steps 3 and 4).

3. With engine stopped, measure resistance across stator leads using an ohmmeter.

Condition	Conclusion
Resistance is 0.064/0.2 ohms.	Stator is OK.
Resistance is 0 ohms.	Stator is shorted; replace.
Resistance is infinity ohms.	Stator is open; replace.

4. With engine stopped, measure resistance from each stator lead to ground using an ohmmeter.

Condition	Conclusion
Resistance is infinity ohms (no continuity).	Stator is OK (not shorted to ground).
Resistance (or continuity) measured.	Stator leads are shorted to ground; replace.

To test charging system for battery continuously charging at high rate:

1. With engine running at 3600 RPM, measure voltage from B+ lead to ground using a DC voltmeter.

Condition	Conclusion
Voltage is 14.7 volts or less.	Charging system is OK. Battery is unable to hold charge; service or replace.
Voltage is more than 14.7 volts.	Faulty rectifier-regulator; replace.

Starter System

NOTE: Do not crank engine continuously for more than 10 seconds. Allow a 60 second cool-down period between starting attempts. Failure to follow these guidelines can burn out starter motor.

NOTE: If engine develops sufficient speed to disengage starter but does not keep running (a false start), engine rotation must be allowed to come to a complete stop before attempting to restart engine. If starter is engaged while flywheel is rotating, starter pinion and flywheel ring gear may clash and damage starter.

NOTE: If starter does not crank engine, shut off starter immediately. Do not make further attempts to start engine until condition is corrected.

NOTE: Do not drop starter or strike starter frame. Doing so can damage starter.

Engines in this series use inertia drive or solenoid shift starters. Inertia drive electric starters are not serviceable

Troubleshooting-Starting Difficulties

Condition	Possible Cause	Conclusion
Starter does not energize.	Battery	Check specific gravity of battery. If low, recharge or replace battery as necessary.
	Wiring	Clean corroded connections and tighten loose connections. Replace wires in poor condition and with frayed or broken insulation.
	Starter Switch or Solenoid	By-pass switch or solenoid with a jumper wire. If starter cranks normally, replace faulty components. Remove and perform individual solenoid test procedure.
Starter energizes but turns slowly.	Battery	Check specific gravity of battery. If low, recharge or replace battery as necessary.
	Brushes	Check for excessively dirty or worn brushes and commutator. Clean using a coarse cloth (not emery cloth). Replace brushes if excessively or unevenly worn.
	Transmission or Engine	Make sure clutch or transmission is disengaged or placed in neutral. This is especially important on equipment with hydrostatic drive. Transmission must be exactly in neutral to prevent resistance which could keep engine from starting. Check for seized engine components such as bearings, connecting rod, and piston.

INERTIA DRIVE ELECTRIC STARTERS

When power is applied to starter, armature rotates. As armature rotates, drive pinion moves out on drive shaft splines and into mesh with flywheel ring gear. When pinion reaches end of drive shaft, it rotates flywheel and cranks engine.

When engine starts, flywheel rotates faster than starter armature and drive pinion. This moves drive pinion out of mesh with ring gear and into retracted position. When power is removed from starter, armature stops rotating and drive pinion is held in retracted position by anti-drift spring.

SOLENOID SHIFT STARTERS

Solenoid Shift Starter Components

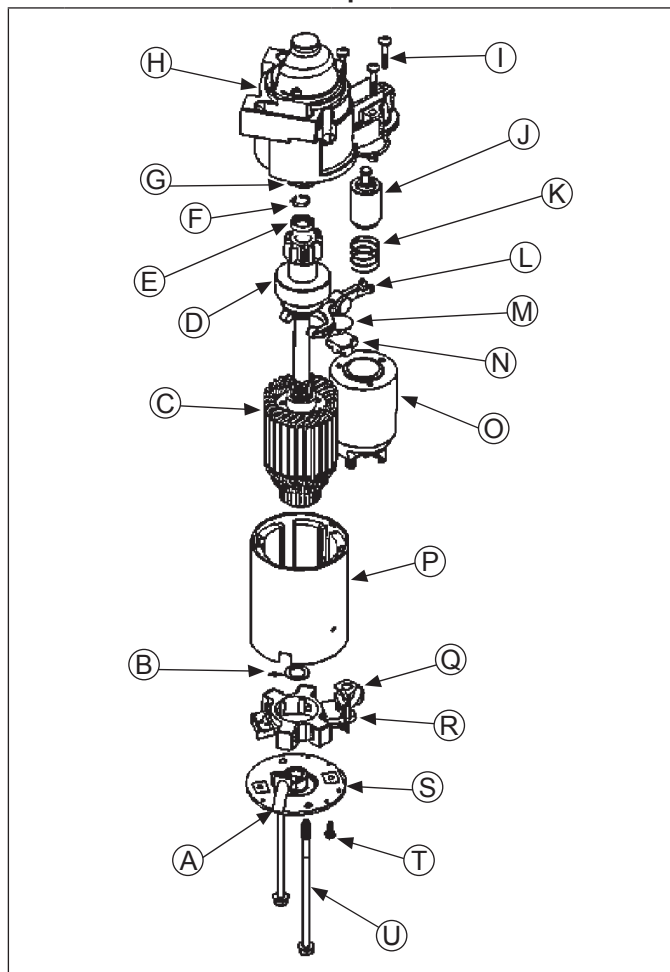

A	Tube	B	Washer
C	Armature	D	Drive
E	Stop	F	Retaining Ring
G	Collar	H	Drive End Cap
I	Screw	J	Plunger
K	Spring	L	Lever
M	Plate	N	Plug
O	Solenoid	P	Frame and Field
Q	Brush Holder	R	Nut
S	Commutator End Plate	T	Screw
U	Bolt		

When power is applied to starter electric solenoid moves drive pinion out onto drive shaft and into mesh with flywheel ring gear. When pinion reaches end of drive shaft it rotates flywheel and cranks engine.

When engine starts and start switch is released, starter solenoid is deactivated, drive lever moves back, and drive pinion moves out of mesh with ring gear into retracted position.

Starter Disassembly

NOTE: Do not reuse old retainer.

NOTE: Do not soak armature or use solvent when cleaning. Wipe clean using a soft cloth, or use compressed air.

1. Remove hex nut and disconnect positive (+) brush lead/bracket from solenoid terminal.
2. Remove head screws securing solenoid to starter.
3. Unhook plunger pin from drive lever. Remove gasket from recess in housing.
4. Remove thru (larger) bolts.
5. Remove commutator end plate assembly, containing brush holder, brushes, springs, and locking caps. Remove thrust washer from inside commutator end.
6. Remove frame from armature and drive end cap.
7. Remove drive lever pivot bushing and backing plate (if equipped) from end cap.
8. Take out drive lever and pull armature out of drive end cap.
9. Remove thrust washer from armature shaft.
10. Push stop collar down to expose retaining ring.
11. Remove retainer from armature shaft. Save stop collar.
12. Remove drive pinion assembly from armature.
13. Clean parts as required.

Inspection

Drive Pinion

Check and inspect following areas:

- Pinion teeth for abnormal wear or damage.
- Surface between pinion and clutch mechanism for nicks or irregularities which could cause seal damage.
- Check drive clutch by holding clutch housing and rotating pinion. Pinion should rotate in only 1 direction.

Brushes and Springs

Detail

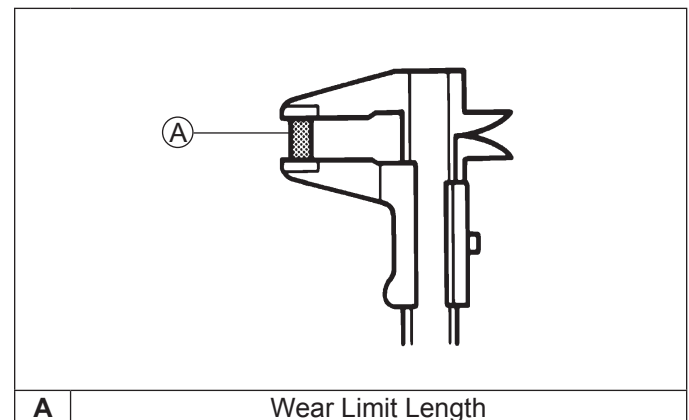

A Wear Limit Length

Inspect both springs and brushes for wear, fatigue, or damage. Measure length of each brush. Minimum length for each brush is 7.6 mm (0.300 in.). Replace brushes if they are worn, undersize, or condition is questionable.

Starter System

Armature Components and Details

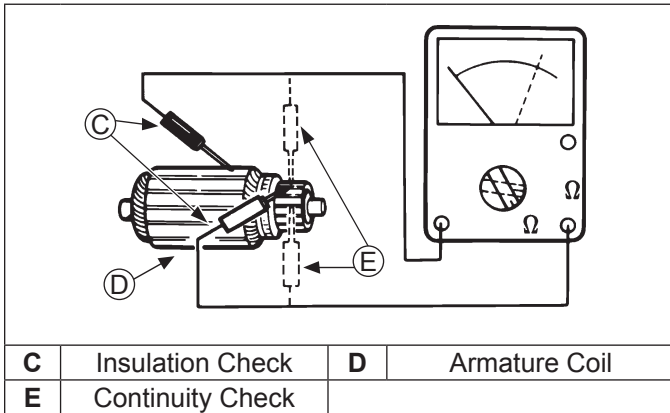
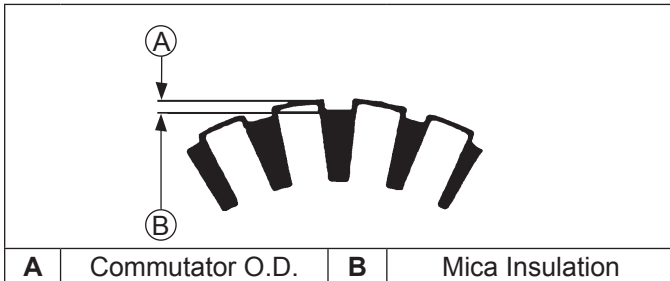

1. Clean and inspect commutator (outer surface). Mica insulation must be lower than commutator bars (undercut) to ensure proper operation of commutator.
2. Use an ohmmeter set to Rx1 scale. Touch probes between 2 different segments of commutator, and check for continuity. Test all segments. Continuity must exist between all or armature is bad.
3. Check for continuity between armature coil segments and commutator segments. There should be no continuity. If continuity exists between any 2 armature is bad.
4. Check armature windings/insulation for shorting.

Shift Fork

Check that shift fork is complete, and pivot and contact areas are not excessively worn, cracked, or broken.

Brush Replacement

4 brushes and springs are serviced as a set. Use a new Rehlko brush and spring kit if replacement is necessary.

1. Perform steps 1-5 in Starter Disassembly.
2. Remove screws securing brush holder assembly to end cap (plate). Note orientation for reassembly later. Discard old brush holder assembly.
3. Clean component parts as required.
New brushes and springs come preassembled in a brush holder with a protective sleeve that will also serve as an installation tool.
4. Perform steps 10-13 in Starter Reassembly sequence. If starter has been disassembled, installation must be done after armature, drive lever, and frame are installed.

Starter Reassembly

NOTE: Always use a new retainer. Do not reuse old retainers that have been removed.

NOTE: Correctly installed, center pivot section of drive lever will be flush or below machined surface of housing.

1. Apply drive lubricant to armature shaft splines. Install drive pinion onto armature shaft.
2. Install and assemble stop collar/retainer assembly.
 - a. Install stop collar down onto armature shaft with counter bore (recess) up.
 - b. Install a new retainer in larger (rear) groove of armature shaft. Squeeze with a pliers to compress it in groove.
 - c. Slide stop collar up and lock it into place, so recess surrounds retainer in groove. If necessary, rotate pinion outward on armature splines against retainer to help seat collar around retainer.
3. Install offset thrust (stop) washer so smaller offset of washer faces retainer/collar.
4. Apply a small amount of oil to bearing in drive end cap, and install armature with drive pinion.
5. Lubricate fork end and center pivot of drive lever with drive lubricant. Position fork end into space between captured washer and rear of pinion.
6. Slide armature into drive end cap and at same time seat drive lever into housing.
7. Install rubber grommet into matching recess of drive end cap. Molded recesses in grommet should be out, matching and aligned with those in end cap.
8. Install frame, with small notch forward, onto armature and drive end cap. Align notch with corresponding section in rubber grommet. Install drain tube in rear cutout, if it was removed previously.
9. Install flat thrust washer onto commutator end of armature shaft.
10. Starter reassembly when replacing brushes/brush holder assembly:

- a. Hold starter assembly vertically on end housing, and carefully position assembled brush holder assembly, with supplied protective tube, against end of commutator/armature. Mounting screw holes in metal clips must be up/out. Slide brush holder assembly down into place around commutator, and install positive (+) brush lead grommet in cutout of frame. Protective tube may be saved and used for future servicing.

Starter reassembly when not replacing brushes/brush holder assembly:

- a. Carefully unhook retaining caps from brush assemblies. Do not lose springs.
- b. Position brushes back in their slots so they are flush with I.D. of brush holder assembly. Insert brush installation tool (with extension), or use tube described above from a prior brush installation, through brush holder assembly, so holes in metal mounting clips are up/out.

- c. Install brush springs and snap on retainer caps.
 - d. Hold starter assembly vertically on end housing, and carefully place tool (with extension) and assembled original brush holder assembly onto end of armature shaft. Slide brush holder assembly down into place around commutator, install positive (+) brush lead grommet in cutout of frame.
11. Install end cap onto armature and frame, aligning thin raised rib in end cap with corresponding slot in grommet of positive (+) brush lead.
 12. Install thru bolts and brush holder mounting screws. Torque bolts to 5.6-9.0 N·m (49-79 in. lb.) and brush holder mounting screws to 2.5-3.3 N·m (22-29 in. lb.).
 13. Hook plunger behind upper end of drive lever and install spring into solenoid. Insert mounting screws through holes in drive end cap. Use these to hold solenoid gasket in position, then mount solenoid. Torque screws to 4.0-6.0 N·m (35-53 in. lb.).
 14. Connect positive (+) brush lead/bracket to solenoid and secure with nut. Torque nut to 8-11 N·m (71-97 in. lb.). Do not overtighten.

Solenoid Tests

NOTE: DO NOT leave 12 volt test leads connected to solenoid for any time over what is necessary for performing each of individual tests. Internal damage to solenoid may occur.

Disconnect all leads from solenoid including positive brush lead attached to lower stud terminal. Remove mounting hardware and separate solenoid from starter for testing.

To test solenoid pull-in coil/plunger:

Actuation

1. Use a 12 volt power supply and 2 test leads.
2. Connect 1 lead to flat spade S/start terminal on solenoid. Momentarily connect other lead to lower large post terminal.

When connection is made solenoid should energize (audible click) and plunger retract. Repeat test several times.

Continuity

1. Use an ohmmeter set to audible or Rx2K scale, and connect 2 ohmmeter leads to 2 large post terminals.
2. Perform solenoid pull-in coil/plunger actuation test and check for continuity. Ohmmeter should indicate continuity. Repeat test several times.

To test solenoid hold-in coil:

Function

1. Connect a 12 volt test lead to flat spade S/start terminal on solenoid and other lead to body or mounting surface of solenoid.
2. Manually push plunger IN and check if coil holds plunger retracted. Do not allow test leads to remain connected to solenoid for a prolonged period of time.

Continuity

1. Use an ohmmeter set to audible or Rx2K scale, and connect 2 ohmmeter leads to 2 large post terminals.
2. Perform preceding solenoid hold-in coil function test and check for continuity. Meter should indicate continuity. Repeat test several times.

Condition	Conclusion
Solenoid fails to activate.	Replace solenoid.
No continuity is indicated.	
Plunger fails to stay retracted.	

Emission Compliant Systems

EVAPORATIVE EMISSION COMPLIANT SYSTEM

Carbon Canister System

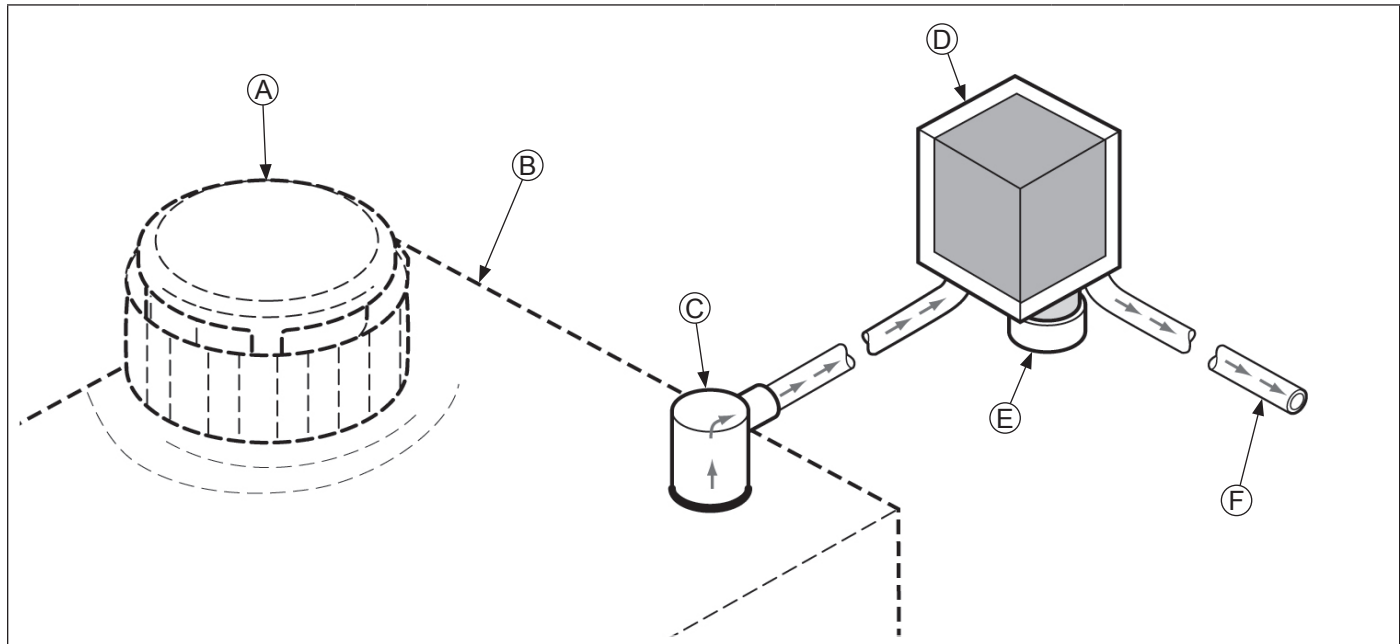

A	Fuel Tank Cap	B	Fuel Tank	C	Roll Over Valve (ROV)	D	Carbon Canister
E	Canister Breather Filter	F	To Carburetor				

For engine to be Tier III compliant, it may be fitted with a Rehlko supplied canister vapor recovery system, or a system developed and installed by Original Equipment Manufacturer (OEM). Details on Rehlko system are included below.

Operation

Fuel vapors travel from fuel tank through tubing to carbon canister. On intake stroke of engine fuel vapors are drawn in through a port in carburetor and burned with fuel charge.

Maintenance

On Rehlko-supplied canisters, breather filter can be removed and cleaned with hot soapy water, dried and reinstalled. Do not oil breather screen. This is done periodically or if system operation is suspect. Carbon canister is sealed and requires no maintenance.

In some applications or installations, OEM will have installed a different canister or fuel vapor recovery system. See OEM equipment documentation for service or maintenance information.

SECONDARY EMISSION COMPLIANT SYSTEM

Twin Secondary Air Induction System

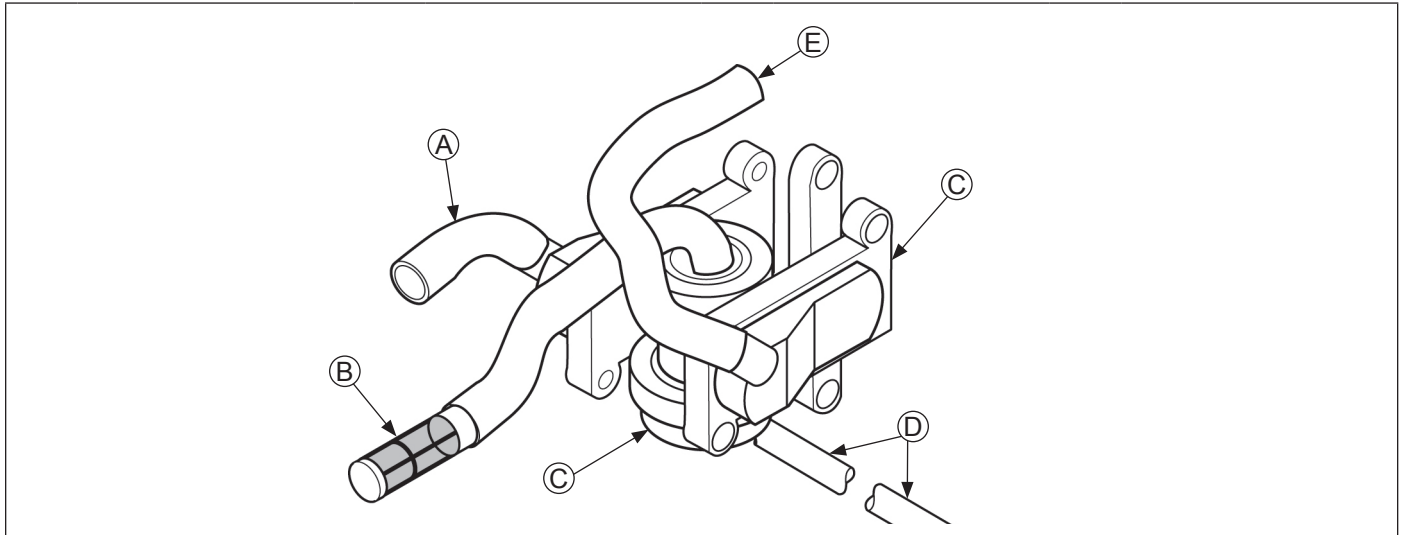

A	Hose To Exhaust Manifold	B	Inlet Screen	C	Secondary Air Valve Assembly	D	Hose To Carburetor
E	Hose To Exhaust Manifold						

Single Secondary Air Induction System

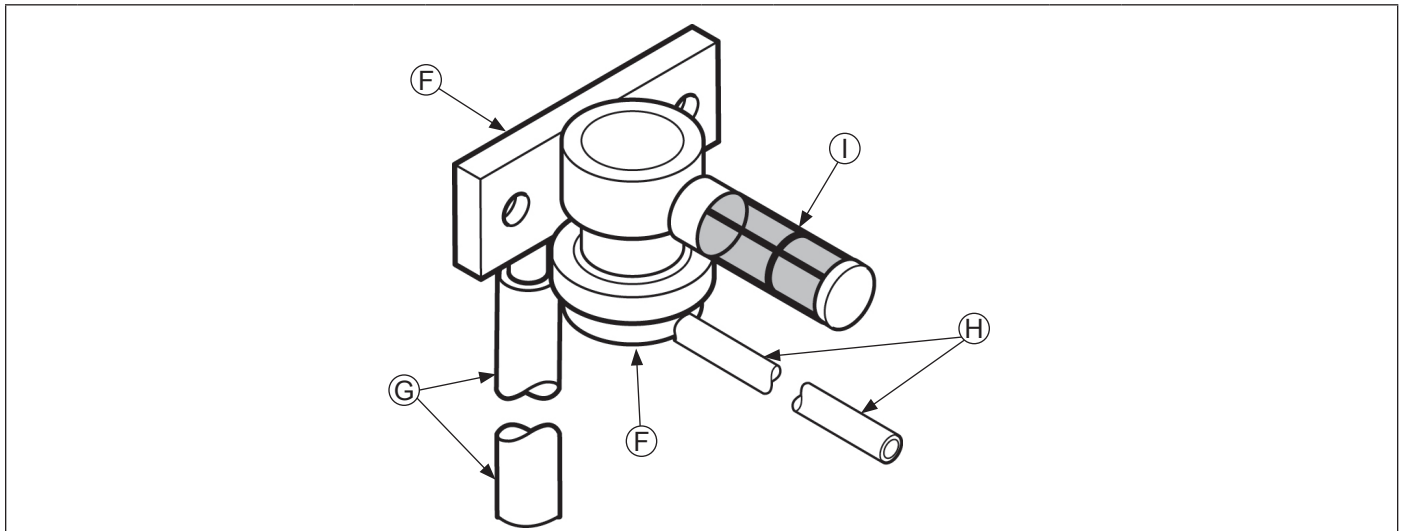

F	Secondary Air Valve Assembly	G	Hose To Exhaust Manifold	H	Hose To Carburetor	I	Inlet Screen
----------	------------------------------	----------	--------------------------	----------	--------------------	----------	--------------

For engine to be Tier III compliant, it may be fitted with a secondary air induction system (SAI).

Operation

Intake pulse of engine activates secondary air valve. Air is drawn through an inlet screen of secondary air valve. Air is then drawn into exhaust manifold and muffler where it mixes with any unburned hydrocarbons, which then burn in heat of muffler. A hose is connected between a carburetor port and a diaphragm chamber in secondary air valve. Carburetor vacuum moves diaphragm to close valve when air induction is not required, primary idle.

Maintenance

Air inlet screen in secondary air valve can be removed, cleaned, and reinstalled. If inspection of system reveals any damage or decomposition of hoses, secondary air valve, or exhaust system, parts should be replaced.

Emission Compliant Systems

Remove Inlet Screen

Inlet Components

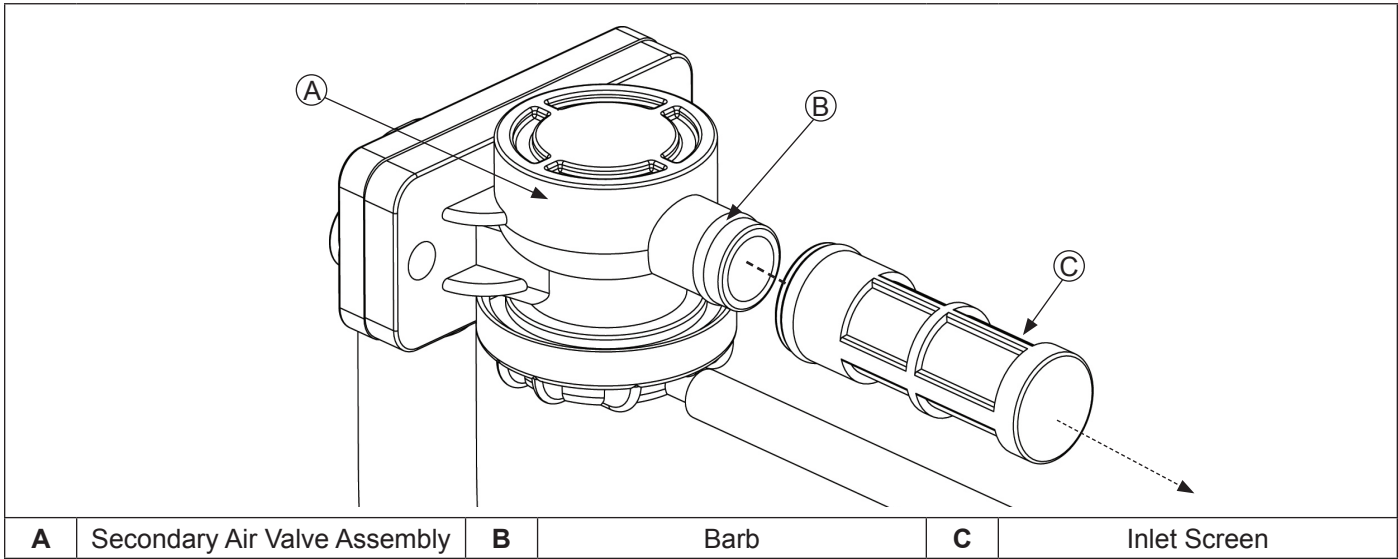

1. Remove inlet screen from secondary air valve assembly by grasping inlet screen at base and gently pulling away from valve assembly.
2. Use a soft brush to remove debris from screen.
3. Run water through inlet screen in reverse direction.
4. To reinstall, push inlet screen onto barb of secondary air valve assembly. An audible click will be heard when inlet screen is properly reinstalled.

Disassembly/Inspection and Service



⚠ WARNING

Accidental Starts can cause severe injury or death.

Disconnect and ground spark plug lead(s) before servicing.

Before working on engine or equipment, disable engine as follows: 1) Disconnect spark plug lead(s). 2) Disconnect negative (-) battery cable from battery.

External Engine Components

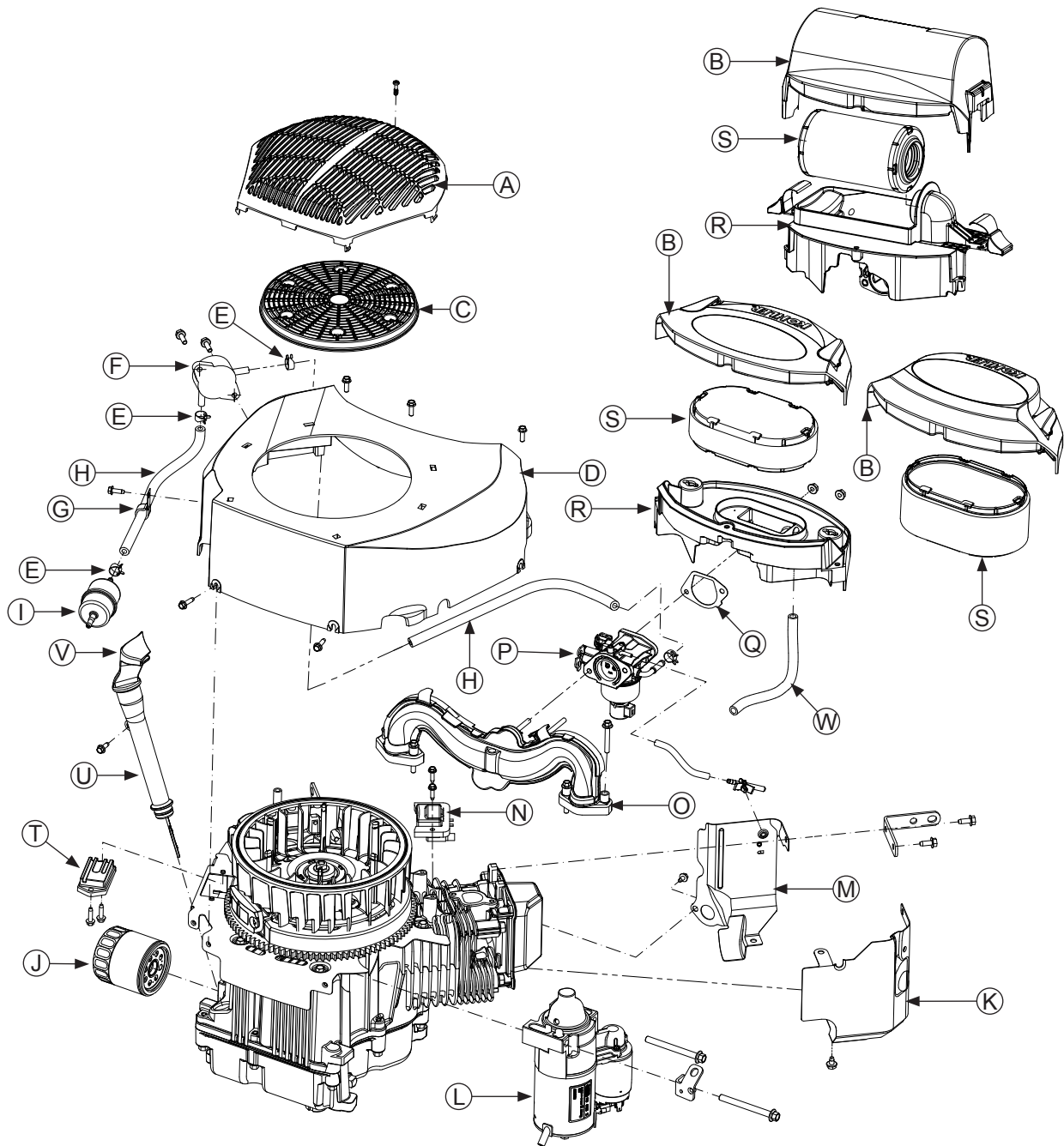

A	Fixed Guard	B	Air Cleaner Cover	C	Debris Screen	D	Blower Housing
E	Hose Clamp	F	Fuel Pump	G	Hose Clip	H	Fuel Line
I	Fuel Filter	J	Oil Filter	K	Outer Baffle	L	Electric Starter
M	Inner Baffle	N	Ignition Module	O	Intake Manifold	P	Carburetor
Q	Gasket	R	Air Cleaner Base	S	Air Cleaner Element	T	Rectifier-Regulator
U	Dipstick Tube	V	Oil Fill/Dipstick	W	Breather Hose		

Disassembly/Inspection and Service

Clean all parts thoroughly as engine is disassembled. Only clean parts can be accurately inspected and gauged for wear or damage. There are many commercially available cleaners that will quickly remove grease, oil and grime from engine parts. When such a cleaner is used, follow manufacturer's instructions and safety precautions carefully.

Make sure all traces of cleaner are removed before engine is reassembled and placed into operation. Even small amounts of these cleaners can quickly break down lubricating properties of engine oil.

Disconnect Spark Plug Leads

NOTE: Pull on boot only, to prevent damage to spark plug lead.

1. Disconnect leads from spark plugs.
2. Shut off fuel supply.



Drain Oil From Crankcase and Remove Oil Filter

1. Remove oil fill/dipstick and oil drain plug.
2. Allow ample time for oil to drain from crankcase and oil filter.
3. Remove and appropriately discard oil filter.

Remove Muffler

Remove exhaust system and attaching hardware from engine.

Remove Fuel Pump (if equipped)

	 WARNING
	<p>Explosive Fuel can cause fires and severe burns.</p> <p>Do not fill fuel tank while engine is hot or running.</p>
<p>Gasoline is extremely flammable and its vapors can explode if ignited. Store gasoline only in approved containers, in well ventilated, unoccupied buildings, away from sparks or flames. Spilled fuel could ignite if it comes in contact with hot parts or sparks from ignition. Never use gasoline as a cleaning agent.</p>	

1. Disconnect pulse (vacuum) hose and outlet fuel line from fuel pump.
2. Remove mounting screws, unhook outlet hose from blower housing clip, and remove fuel pump from blower housing.

Remove Blower Housing and Outer Baffles

1. Remove air cleaner cover.
2. Remove screws securing blower housing.
3. Remove blower housing from engine.
4. Remove M5 and M6 screws securing baffles to cylinders, heads and backing plate.

Remove Throttle Controls

Control Bracket Components

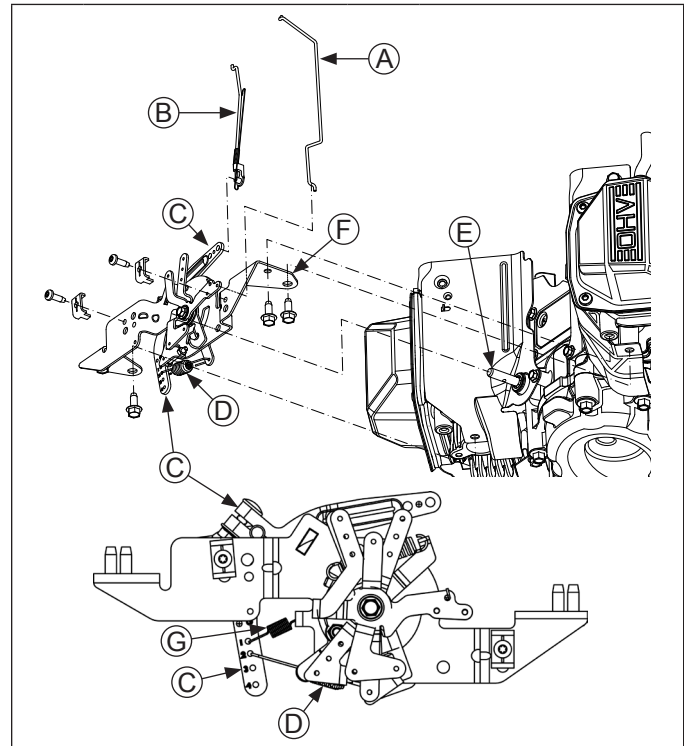

A	Choke Linkage	B	Throttle Linkage
C	Governor Lever	D	Governor Spring
E	Cross Shaft	F	Control Bracket
G	Dampener Spring		

1. Remove screws securing throttle control bracket to cylinder heads.
2. Disconnect choke linkage from choke actuator lever. Unhook governor spring, and dampener spring from governor lever. Note hole locations for reassembly.

Remove External Governor Controls

Loosen nut and remove governor lever from cross shaft. Leave lever attached to throttle linkage.

Remove Air Cleaner and Carburetor

	⚠ WARNING
	<p>Explosive Fuel can cause fires and severe burns.</p> <p>Do not fill fuel tank while engine is hot or running.</p>
<p>Gasoline is extremely flammable and its vapors can explode if ignited. Store gasoline only in approved containers, in well ventilated, unoccupied buildings, away from sparks or flames. Spilled fuel could ignite if it comes in contact with hot parts or sparks from ignition. Never use gasoline as a cleaning agent.</p>	

Smart-Choke™ and eChoke™ Carburetor/Air Cleaner Components

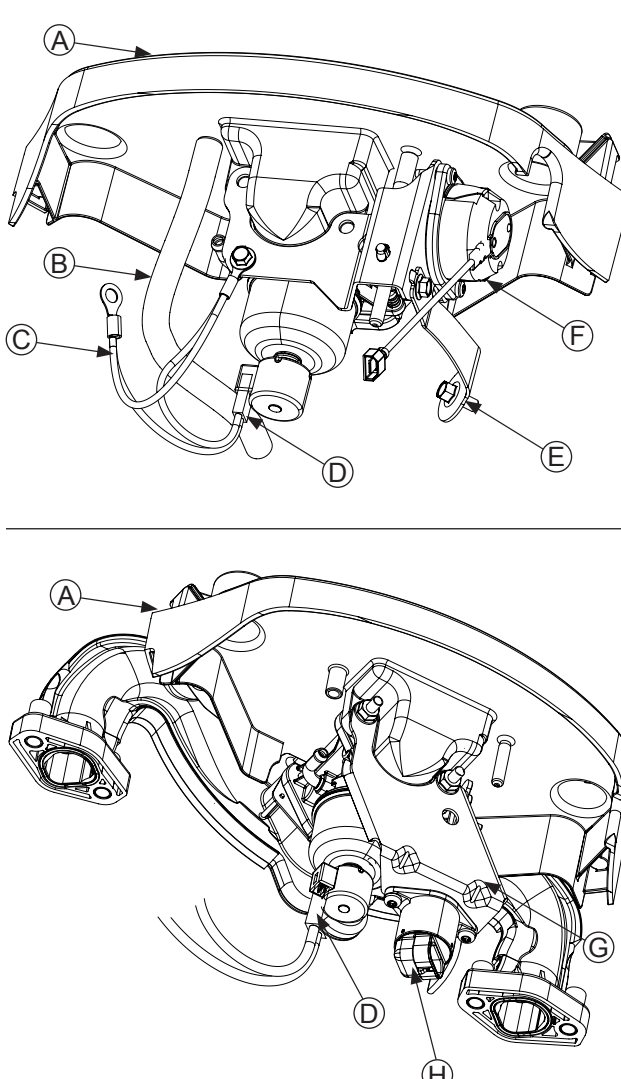

A	Air Cleaner Base	B	Breather Hose
C	Ground Lead	D	Solenoid Lead

E	Smart-Choke™ Bracket Assembly	F	Thermostat
G	eChoke™ Bracket Assembly	H	Stepper Motor

NOTE: On engines equipped with eChoke™, stepper motor has a special retract routine that can be activated to ensure motor is in correct position prior to removal or upon replacement of stepper motor when a problem is shown to exist with stepper motor assembly and carburetor. Activation of this routine will occur by initiating three (3) consecutive Key On–Off cycles. Every Key On and Off should be > 2 seconds and < 3.5 seconds. Note that if no other connections are disturbed, stepper motor will be repositioned at next key ON and master module will go back to normal choke operation mode.

NOTE: Do not remove or loosen thermostat screws. Position is set at factory.

1. Remove carburetor/air cleaner base mounting nuts and disconnect breather hose.
2. Remove air cleaner element and precleaner (if equipped) from air cleaner base for servicing.
3. Disconnect ground lead and fuel shut-off solenoid lead (if equipped).
4. Remove Smart-Choke™ or eChoke™ bracket assembly (if equipped). Remove air cleaner base and gasket.
5. Remove carburetor, throttle linkage and governor lever as an assembly.
6. Remove carburetor gasket.
7. If necessary, carburetor, throttle linkage and governor lever can be separated. Reattach bushings to linkage following separation to avoid losing them.

Remove Electric Starter Motor

1. Disconnect leads from starter.
2. Remove screws and starter.

Remove Inner Baffles

Remove mounting screws securing inner baffles to crankcase. Note position of any lifting bracket(s). Remove inner baffles.

Remove Ignition Modules

NOTE: Some early production engines equipped with Smart-Choke™, have a deflector support tab on #2 cylinder ignition module. If equipped, note position for reassembly.

1. Rotate flywheel so magnet is away from modules.
2. Disconnect lead from each ignition module.
3. Remove mounting screws and ignition modules. Note position of ignition modules.

Disassembly/Inspection and Service

Remove Intake Manifold and Rectifier-Regulator

1. Remove screws securing intake manifold to cylinder heads. Note which screws hold wiring clamp(s).
2. On engines equipped with Smart-Choke™, disconnect choke unloader linkage from carburetor. Unless air vane deflector is damaged or malfunctioning, disassembly from intake manifold is not necessary.
3. Remove intake manifold and O-rings. Leave wiring harness attached to manifold.
4. Remove screws securing rectifier-regulator to backing plate and disconnect plug.
5. Use tip of a small screwdriver or similar small flat tool to bend locking tang, then remove B+ (center lead) from terminal plug. This will allow intake manifold to be removed with wiring harness intact.

Cylinder Head Components

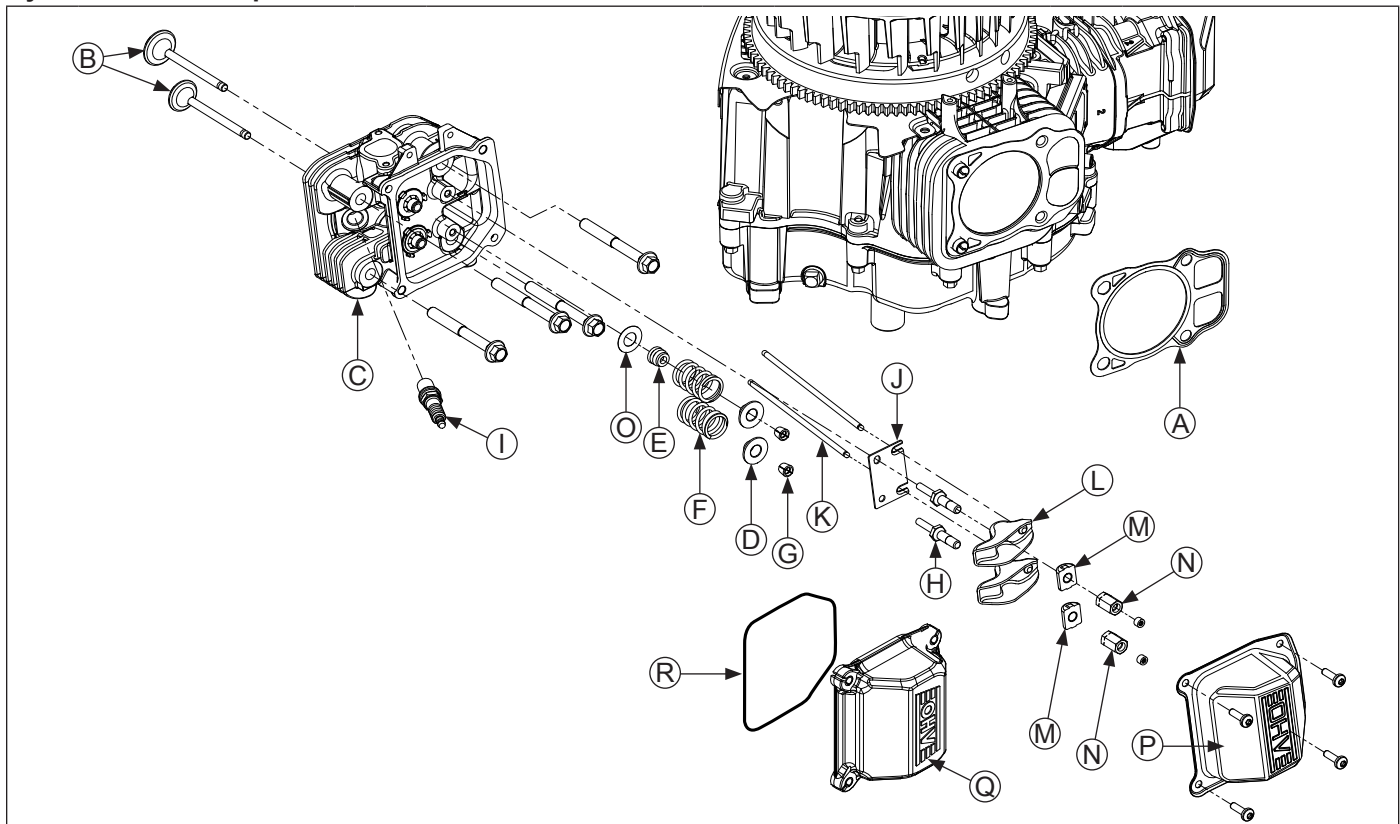

A	Gasket	B	Valve	C	Cylinder Head	D	Valve Spring Cap
E	Valve Stem Seal	F	Valve Spring	G	Valve Spring Keeper	H	Stud
I	Spark Plug	J	Guide Plate	K	Push Rod	L	Rocker Arm
M	Rocker Arm Pivots	N	Adjusters	O	Washer	P	Stamped Steel Valve Cover (RTV)
Q	Plastic Valve Cover (O-Ring)	R	O-Ring				

Remove Spark Plugs

Remove spark plug from each cylinder head.

Remove Valve Covers and Cylinder Heads

Plastic Valve Covers with O-Rings

Remove screws securing each valve cover. Most valve covers have screw hole spacers molded in place. Remove valve covers and O-rings.

Stamped Steel Valve Covers with RTV Sealant

NOTE: Valve cover is sealed to cylinder head using RTV silicone sealant. When removing valve cover, use care not to damage gasket surfaces of cover and cylinder head. To break RTV seal, hold a block of wood against 1 flat face of valve cover. Strike wood firmly with a mallet. If seal doesn't break loose after 1 or 2 attempts, repeat procedure on other side.

1. Remove Torx screws securing each valve cover.
2. Using a brass wire brush and gasket remover or similar solvent, clean old RTV from surface of cylinder head and valve cover.
3. Sealing surface of stamped steel valve covers must be checked for flatness prior to reinstallation. Hold valve cover down firmly against a flat, level surface or piece of glass, and check around entire perimeter that a 0.012 in. (0.30 mm) feeler gauge cannot be inserted anywhere. If gauge goes in anywhere, cover needs to be replaced.

Remove Cylinder Heads

NOTE: Exhaust side is located on output shaft side of engine, while intake side is located on fan side of engine. Cylinder head number is embossed on outside of each cylinder head.

1. Loosen inner setscrews (T25 Torx), and back off adjusters.
2. Mark location of push rods as either intake or exhaust and cylinder 1 or 2. Push rods should always be installed in same positions.
3. Remove screws securing each cylinder head.
4. Remove cylinder head and head gasket.

Disassemble Cylinder Heads

NOTE: Use a new valve stem seal whenever valve is removed or if valve stem seal is deteriorated or damaged. Never reuse an old valve stem seal.

1. Remove adjusters, pivots, rocker arms, studs and guide plate from cylinder head.
2. Compress valve springs using a valve spring compressor.
3. Once valve spring is compressed, remove following items.
 - Valve spring keepers.
 - Valve spring caps.
 - Valve springs.
 - Intake and exhaust valves (mark position).
 - Valve stem seal.
 - Washer (intake valve only).
4. Repeat above procedure for other cylinder head. Do not interchange parts from 1 cylinder head to another.

Disassembly/Inspection and Service

Inspection and Service Valve Details

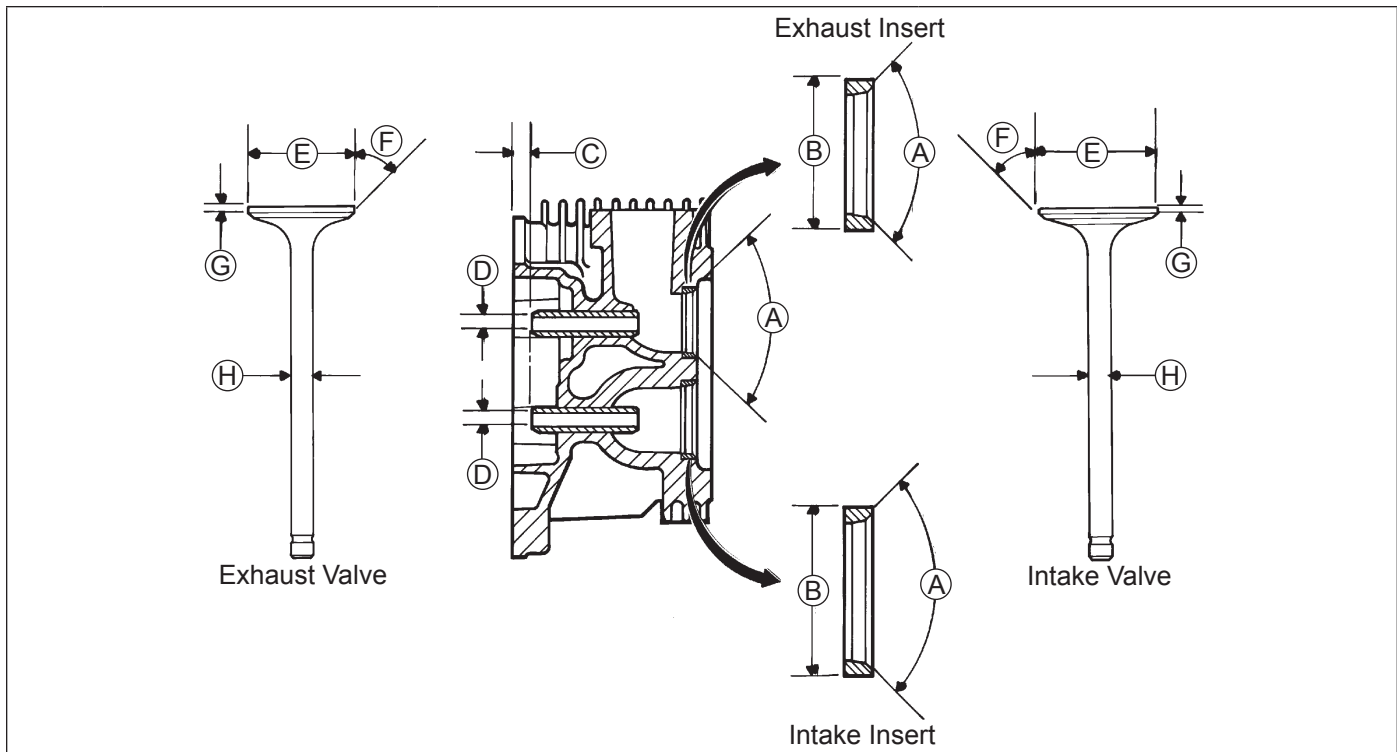

Dimension		Intake	Exhaust
A	Seat Angle	89°	89°
B	Insert O.D.	36.987/37.013 mm (1.4562/1.4572 in.)	32.987/33.013 mm (1.2987/1.2997 in.)
C	Guide Depth	4 mm (0.1575 in.)	6.5 mm (0.2559 in.)
D	Guide I.D.	7.040/7.060 mm (0.2772/0.2780 in.)	7.040/7.060 mm (0.2772/0.2780 in.)
E	Valve Head Diameter	33.37/33.63 mm (1.3138/1.3240 in.)	29.37/29.63 mm (1.1563/1.1665 in.)
F	Valve Face Angle	45°	45°
G	Valve Margin (Min.)	1.5 mm (0.0591 in.)	1.5 mm (0.0591 in.)
H	Valve Stem Diameter	6.982/7.000 mm (0.2749/0.2756 in.)	6.970/6.988 mm (0.2744/0.2751 in.)

After cleaning, check flatness of cylinder head and corresponding top surface of crankcase, using a surface plate or precision straight edge and feeler gauge. Maximum allowable out of flatness is 0.076 mm (0.003 in.).

Carefully inspect valve mechanism parts. Inspect valve springs and related hardware for excessive wear or distortion. Check valves and valve seat area or inserts for evidence of deep pitting, cracks, or distortion.

Check clearance of valve stems in guides. See valve details and specifications.

Hard starting, or loss of power accompanied by high fuel consumption may be symptoms of faulty valves. Although these symptoms could also be attributed to worn rings, remove and check valves first. After removal, clean valve heads, faces, and stems with a power wire brush. Then, carefully inspect each valve for defects such as warped head, excessive corrosion, or worn stem end. Replace valves found to be in bad condition.

Valve Guides

If a valve guide is worn beyond specifications, it will not guide valve in a straight line. This may result in burnt valve faces or seats, loss of compression, and excessive oil consumption.

To check valve guide-to-valve stem clearance, thoroughly clean valve guide and, using a split-ball gauge, measure inside diameter of guide. Then, using an outside micrometer, measure diameter of valve stem at several points on stem where it moves in valve guide. Use largest stem diameter to calculate clearance by subtracting stem diameter from guide diameter. If intake clearance exceeds 0.040/0.078 mm (0.0016/0.0031 in.) or exhaust clearance exceeds 0.052/0.090 mm (0.0020/0.0035 in.), determine whether valve stem or guide is responsible for excessive clearance.

Maximum (I.D.) wear on intake valve guide is 7.140 mm (0.2811 in.) while 7.160 mm (0.2819 in.) is maximum allowed on exhaust guide. Guides are not removable but can be reamed 0.25 mm (0.010 in.) oversize. Valves with 0.25 mm oversize stems must then be used.

If guides are within limits but valve stems are worn beyond limits, install new valves.

Valve Seat Inserts

Hardened steel alloy intake and exhaust valve seat inserts are press-fitted into cylinder head. Inserts are not replaceable but can be reconditioned if not too badly pitted or distorted. If cracked or badly warped, cylinder head should be replaced.

Recondition valve seat inserts following instructions provided with valve seat cutter being used. Final cut should be made with an 89° cutter as specified for valve seat angle. Cutting proper 45° valve face angle, as specified, and proper valve seat angle (44.5°, half of full 89° angle), will achieve desired 0.5° (1.0° full cut) interference angle where maximum pressure occurs on outside diameters of valve face and seat.

Lapping Valves

NOTE: Exhaust valves that are black in color cannot be ground and do not require lapping.

Reground or new valves must be lapped in, to provide fit. Use a hand valve grinder with suction cup for final lapping. Lightly coat valve face with fine grade of grinding compound, then rotate valve on seat with grinder. Continue grinding until smooth surface is obtained on seat and on valve face. Thoroughly clean cylinder head in soap and hot water to remove all traces of grinding compound. After drying cylinder head, apply a light coating of SAE 10 oil to prevent rusting.

Intake Valve Stem Seal

Always use a new seal when valves are removed from cylinder head. Seals should also be replaced if deteriorated or damaged in any way. Never reuse an old seal.

Flywheel/Ignition/Breather Components

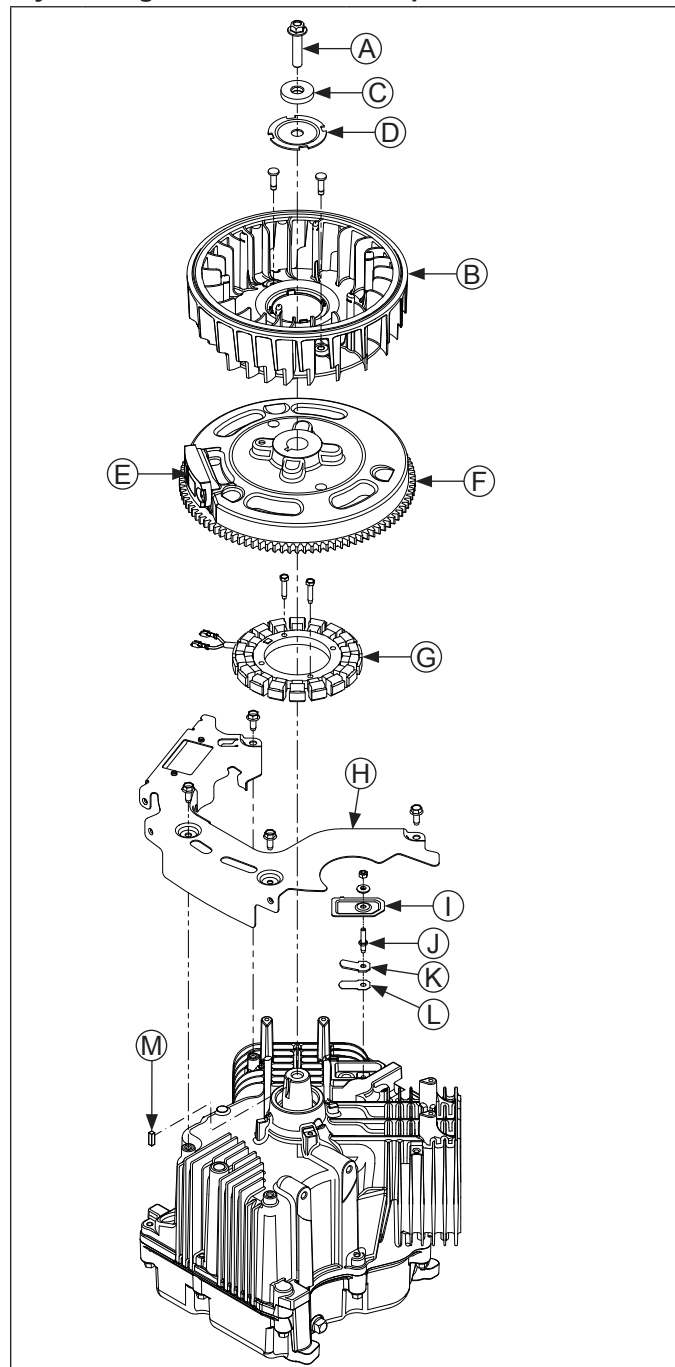

A	Flywheel Screw	B	Fan
C	Washer	D	Fan Mounting Plate
E	Magnet	F	Flywheel
G	Stator	H	Backing Plate
I	Breather Reed Cover	J	Stud
K	Retainer	L	Breather Reed
M	Flywheel Key		

Disassembly/Inspection and Service

Remove Debris Screen, Fan, and Flywheel

NOTE: Always use a flywheel strap wrench or flywheel holding tool (see Tools and Aids) to hold flywheel when loosening or tightening flywheel and fan retaining fasteners. Do not use any type of bar or wedge between fins of cooling fan, as fins could become cracked or damaged.

NOTE: Always use a puller to remove flywheel from crankshaft. Do not strike crankshaft or flywheel, as these parts could become cracked or damaged. Striking puller or crankshaft can cause crank gear to move, affecting crankshaft endplay.

1. Unsnap debris screen from cooling fan.
2. Remove retaining screw, washer, and fan mounting plate, securing fan and flywheel to crankshaft.
3. Lift cooling fan to disengage 2 drive pins and remove it from flywheel. Two plastic retainers may remain in fan.
4. Remove flywheel from crankshaft by pulling from under ring gear with large gear puller.
5. Remove flywheel key from crankshaft.

Flywheel Inspection

Inspect flywheel for cracks, and flywheel keyway for damage. Replace flywheel if it is cracked. Replace flywheel, crankshaft, and key if flywheel key is sheared or keyway is damaged.

Inspect ring gear for cracks or damage. Rehlko does not provide ring gears as a serviceable part. Replace flywheel if ring gear is damaged.

Remove Backing Plate and Stator

1. Remove mounting screws and backing plate from crankcase.
2. Remove screws and stator. Note routing of stator leads.

Remove Breather Reed Assembly

1. RTV sealant is used between breather reed cover and crankcase. Remove nut and sealing (flat) washer securing breather reed cover to crankcase. Carefully pry under small tab of cover flange to separate and remove. Do not bend or distort cover.
2. Unscrew and remove mounting stud, retainer and breather reed.

Crankshaft/Governor Gear/Oil Pump Components

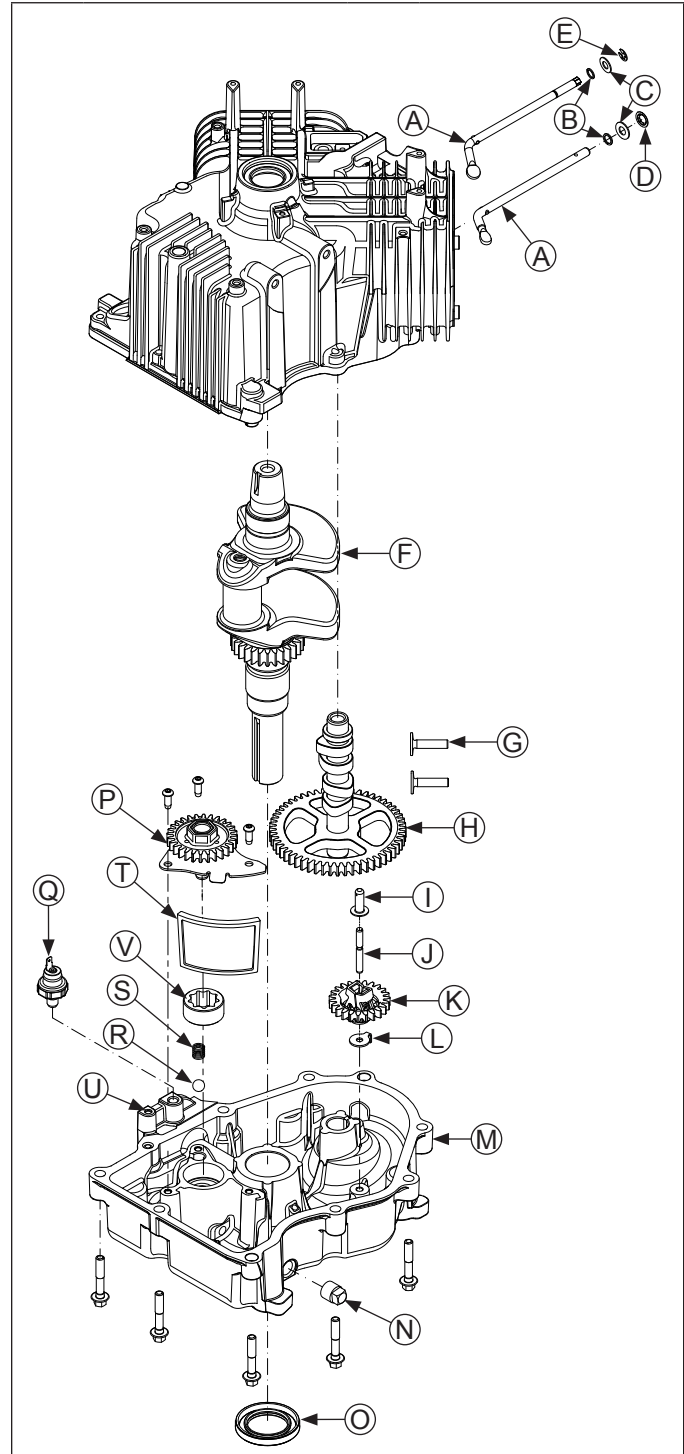

A	Governor Cross Shaft	B	Lower Washer
C	Nylon Washer	D	Push-on Retaining Ring
E	E-Clip	F	Crankshaft
G	Valve Tappets	H	Camshaft
I	Regulating Pin	J	Shaft

Disassembly/Inspection and Service

K	Governor Gear	L	Locking Tab Thrust Washer
M	Oil Pan	N	Drain Plug
O	Oil Seal	P	Oil Pump
Q	Oil Sentry™	R	Ball
S	Spring	T	Oil Pick-up Screen
U	Ground Strap Location	V	Outer Gerotor Gear

Remove Oil Pan Assembly

1. Remove screws securing oil pan to crankcase.
2. Locate splitting tab cast into perimeter of oil pan. Insert drive end of a 1/2" breaker bar between splitting tab and crankcase and turn it to break RTV seal. Do not pry on sealing surfaces as this can cause leaks.

Inspection

Inspect oil seal in oil pan and remove it if it is worn or damaged. New oil seal is installed after oil pan is assembled to crankcase. See Reassembly, Oil Seal in Oil Pan.

Inspect main bearing surface for wear or damage (refer to Specifications). Replace oil pan assembly if required.

Governor Assembly

Governor gear assembly is located inside oil pan. If service is required, continue following steps.

Inspection

Inspect governor gear teeth. Replace gear if it is worn, chipped, or if any teeth are missing. Inspect governor weights. They should move freely in governor gear.

Disassembly

Governor Shaft Component and Details

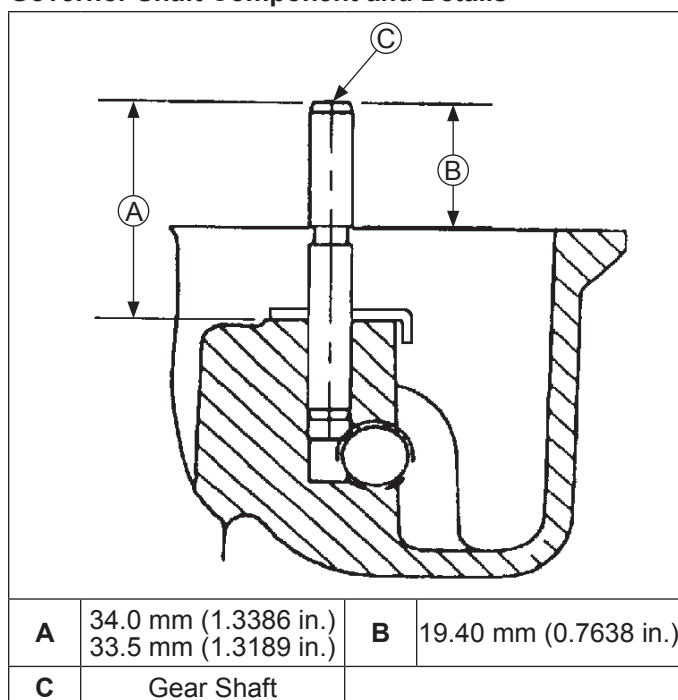

NOTE: Governor gear is held onto shaft by small molded tabs in gear. When gear is removed from shaft, these tabs are destroyed and gear must be replaced. Therefore, remove gear only if absolutely necessary.

Governor gear must be replaced once it is removed from oil pan.

1. Use 2 small screwdrivers and carefully pry upward to remove regulating pin and governor gear assembly.
2. Remove locking tab thrust washer located under governor assembly.
3. Carefully inspect governor gear shaft and replace it only if it is damaged. After removing damaged shaft, press or lightly tap replacement shaft into oil pan to depth shown.

Reassembly

1. Install locking tab thrust washer on governor gear shaft with tab down.
2. Position regulating pin within governor gear/flyweights assembly and slide both onto governor shaft until assembly locks into place.

Oil Pump Assembly

Oil pump is mounted inside oil pan. If service is required, continue with Disassembly, Inspection, and Reassembly.

Disassembly

1. Remove screws.
2. Lift oil pump assembly from oil pan. Remove outer gerotor gear from oil pan.
3. Ensure ball and spring remain installed in pressure relief hole of oil pan. If ball and spring fall out of pressure relief hole, see reassembly for correct installation.

Inspection

Inspect oil pump housing, gear, and rotors for nicks, burrs, wear, or any visible damage. If any parts are worn or damaged, replace oil pump assembly. Check oil pickup screen for damage or restriction, replace if necessary. Disassembly of oil pump is not recommended.

Reassembly

1. Lubricate outer gerotor gear with oil. Install outer gerotor gear through shaft of oil pump, around inner gerotor gear. Matching molding dots on inner and outer gerotor gears is not necessary and will not affect oil pump efficiency.
2. Reinstall ball, then spring into pressure relief hole of oil pan.
3. Install oil pump inserting center shaft into corresponding recess in oil pan. Secure oil pump by torquing screws (in no specific sequence) to 9.9 N·m (88 in. lb.).
4. After torquing, rotate gear and check for freedom of movement. Make sure there is no binding. If binding occurs, loosen screws, reposition pump, retorque screws and recheck movement.

Disassembly/Inspection and Service

Remove Camshaft and Valve Tappets

1. Position crankcase so flywheel side is down. Remove camshaft and shim.
2. Remove valve tappets from crankcase and mark them by their location, as either intake or exhaust and cylinder 1 or 2. Tappets should always be reinstalled in same position.

Camshaft Inspection and Service

Check lobes of camshaft for wear or damage. See Specifications for minimum lift specifications. Inspect cam gear for badly worn, chipped or missing teeth. Replacement of camshaft will be necessary if any of these conditions exist.

Valve Tappets Inspection

Check base surface of valve tappet(s) for wear or damage. Replace tappet(s) if condition is questionable in any way. Corresponding camshaft lobe(s) should also be checked for wear or damage. Whenever tappets are replaced, apply a liberal coating of Rehlko lubricant to base of each new tappet before it is installed.

Remove Governor Cross Shaft

Governor Cross Shaft Oil Seal Details

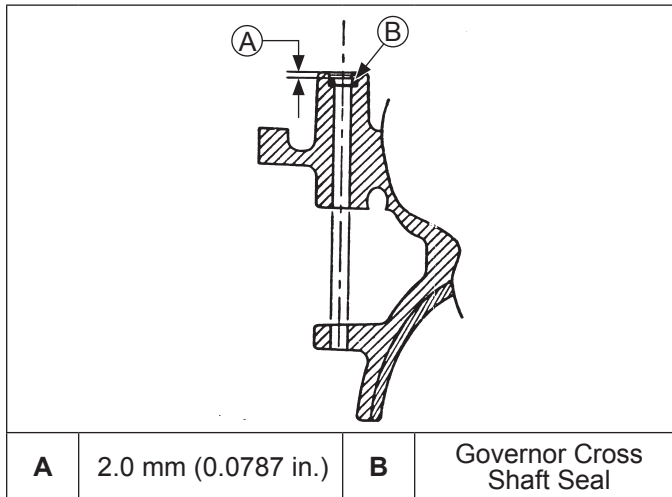

1. **Round Cross Shaft End:** Remove push-on retaining ring and nylon washer from governor cross shaft.
7 mm Hex Cross Shaft End: Remove E-Clip and nylon washer from governor cross shaft.
2. Remove cross shaft with lower washer through inside of crankcase.
3. Remove governor shaft seal from crankcase.

If governor cross shaft seal is damaged and/or leaks, replace it using following procedure.

Remove oil seal from crankcase and replace it with a new one. Apply a light coat of P80 Emulsion Lubrication (refer to Tools and Aids) to outside diameter of oil seal. Install new seal to depth shown using a seal installer.

Connecting Rods/Piston/Breather Components

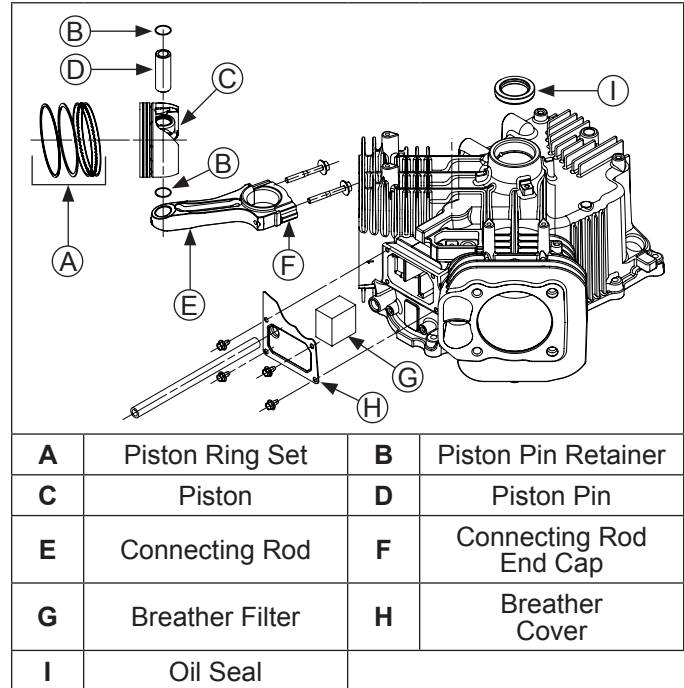

Remove Breather Assembly

Breather system is designed to control amount of oil in head area and still maintain necessary vacuum in crankcase.

When pistons move downward, crankcase gases are pushed past reed through breather filter into intake system. Upward travel of pistons closes reed and creates a low vacuum in lower crankcase. Any oil separated out through filter drains back into crankcase.

1. Remove screws securing breather cover to crankcase.
2. Carefully remove cover and breather filter. Make sure drain back hole is not plugged or restricted.

Remove Connecting Rods with Pistons and Rings

NOTE: If a carbon ridge is present at top of either cylinder bore, use a ridge reamer tool to remove it before attempting to remove piston.

NOTE: Cylinders are numbered on crankcase. Use numbers to mark each end cap, connecting rod and piston for reassembly. Do not mix end caps and connecting rods.

1. Remove screws securing closest connecting rod end cap. Remove end cap.
2. Carefully remove connecting rod and piston assembly from cylinder bore.
3. Repeat above procedure for other connecting rod and piston assembly.

Connecting Rods

Offset, stepped-cap connecting rods are used in all these engines.

Inspection and Service

Check bearing area (big end) for excessive wear, score marks, running and side clearances (See Specifications). Replace rod and cap if scored or excessively worn.

Service replacement connecting rods are available in STD size and 0.25 mm (0.010 in.) undersize. Undersized rods, 0.25 mm (0.010 in.), have an identification marking on lower end of rod shank. Always refer to appropriate parts information to ensure correct replacements are used.

Piston and Rings

Inspection

Piston and Rings Components and Details

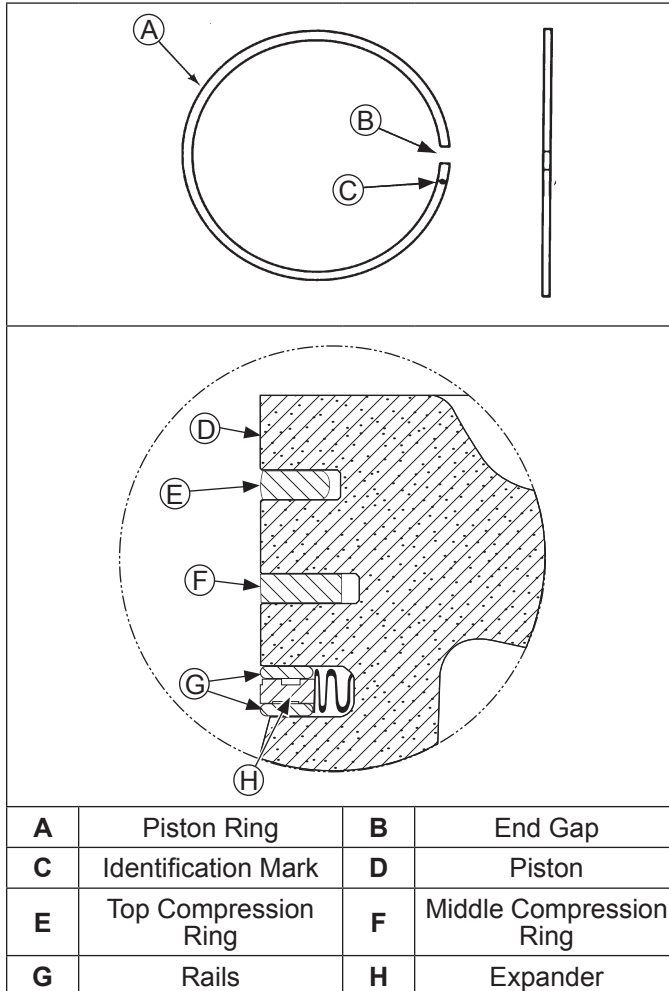

Scuffing and scoring of pistons and cylinder walls occurs when internal engine temperatures approach welding point of piston. Temperatures high enough to do this are created by friction, which is usually attributed to improper lubrication and/or overheating of engine.

Normally, very little wear takes place in piston boss-piston pin area. If original piston and connecting rod can be reused after new rings are installed, original pin can also be reused but new piston pin retainers are required. A piston pin is included as part of piston assembly – if pin boss in piston or pin are worn or damaged, a new piston assembly is required.

Ring failure is usually indicated by excessive oil consumption and blue exhaust smoke. When rings fail, oil is allowed to enter combustion chamber where it is burned along with fuel. High oil consumption can also occur when piston ring end gap is incorrect because ring cannot properly conform to cylinder wall under this condition. Oil control is also lost when ring gaps are not staggered during installation.

When cylinder temperatures get too high, lacquer and varnish collect on pistons causing rings to stick, which results in rapid wear. A worn ring usually takes on a shiny or bright appearance.

Scratches on rings and pistons are caused by abrasive material such as carbon, dirt, or pieces of hard metal.

Detonation damage occurs when a portion of fuel charge ignites spontaneously from heat and pressure shortly after ignition. This creates 2 flame fronts, which meet and explode to create extreme hammering pressures on a specific area of piston. Detonation generally occurs from using low octane fuels.

Pre-ignition or ignition of fuel charge before timed spark can cause damage similar to detonation. Pre-ignition damage is often more severe than detonation damage. Pre-ignition is caused by a hot spot in combustion chamber such as glowing carbon deposits, blocked cooling fins, an improperly seated valve, or wrong spark plug(s).

Replacement pistons are available in STD bore size, and 0.25 mm (0.010 in.) oversize. Replacement pistons include new piston ring sets and new piston pins.

Replacement ring sets are also available separately for STD, and 0.25 mm (0.010 in.) oversize pistons. Always use new piston rings when installing pistons. Never use old rings.

Some important points to remember when servicing piston rings:

1. Cylinder bore must be de-glazed before service ring sets are used.
2. If cylinder bore does not need re-boring and if old piston is within wear limits and free of score or scuff marks, old piston may be reused.
3. Remove old rings and clean up grooves. Never reuse old rings.
4. Before installing new rings on piston, place top 2 rings, each in turn, in its running area in cylinder bore and check end gap. Top compression ring end gap clearance is 0.189/0.277 mm (0.0074/0.0109 in.) for a new bore, or 0.531 mm (0.0209 in.) for a used bore. Middle compression ring end cap is 1.519/1.797 mm (0.0598/0.0708 in.) for a new bore, or 2.051 mm (0.0808 in.) for a used bore.
5. After installing new compression (top and middle) rings on piston, make sure top compression ring-to-groove side clearance and is 0.030/0.070 mm (0.0010/0.0026 in.) and middle compression ring-to-groove side clearance 0.030/0.070 mm (0.0010/0.026 in.). If side clearance is greater than specified, a new piston must be used.

Disassembly/Inspection and Service

Install New Piston Rings

NOTE: Rings must be installed correctly. Ring installation instructions are usually included with new ring sets. Follow instructions carefully. Use a piston ring expander to install rings. Install bottom (oil control) ring first and top compression ring last.

To install new piston rings, proceed as follows:

1. Oil control ring (bottom groove): Install expander and then rails. Make sure ends of expander are not overlapped.
2. Middle compression ring (center groove): Install center ring using a piston ring expander tool. Make sure identification mark is up or colored dye stripe (if contained) is to left of end gap.
3. Top compression ring (top groove): Install top ring using a piston ring expander tool. Make sure identification mark is up or colored dye stripe (if contained) is left of end gap.

Remove Crankshaft

Carefully pull crankshaft from crankcase.

Inspection and Service

Inspect gear teeth of crankshaft. If teeth are badly worn, chipped, or some are missing, replacement of crankshaft will be necessary.

Inspect crankshaft bearing surfaces for scoring, grooving, etc. Measure running clearance between crankshaft journals and their respective bearing bores. Use an inside micrometer or telescoping gauge to measure inside diameter of both bearing bores in vertical and horizontal planes. Use an outside micrometer to measure outside diameter of crankshaft main bearing journals. Subtract journal diameters from their respective bore diameters to get running clearances. Check results against values in Specifications. If running clearances are within specification, and there is no evidence of scoring, grooving, etc., no further reconditioning is necessary. If bearing surfaces are worn or damaged, crankcase and/or oil pan will need to be replaced.

Inspect crankshaft keyways. If worn or chipped, replacement of crankshaft will be necessary.

Inspect crankpin for score marks or metallic pickup. Slight score marks can be cleaned with crocus cloth soaked in oil. If wear limits are exceeded, as stated in Specifications, it will be necessary to replace crankshaft.

Remove Flywheel and PTO End Oil Seals

Remove oil seals from crankcase and oil pan.

Crankcase

Inspection and Service

Check all gasket surfaces to make sure they are free of gasket fragments. Gasket surfaces must also be free of deep scratches or nicks.

Check cylinder bore for scoring. In severe cases, unburned fuel can cause scuffing and scoring of cylinder wall. It washes necessary lubricating oils off piston and cylinder wall. As raw fuel seeps down cylinder wall, piston rings make metal to metal contact with wall. Scoring of cylinder wall can also be caused by localized hot spots resulting from blocked cooling fins or from inadequate or contaminated lubrication.

If cylinder bore is badly scored, excessively worn, tapered, or out-of-round, resizing is necessary. Use an inside micrometer to determine amount of wear (refer to Specifications). A 0.25 mm (0.010 in.) oversize piston is available if resizing is selected. Initially, resize using a boring bar, then use these following procedures for honing cylinder.

Honing

Details

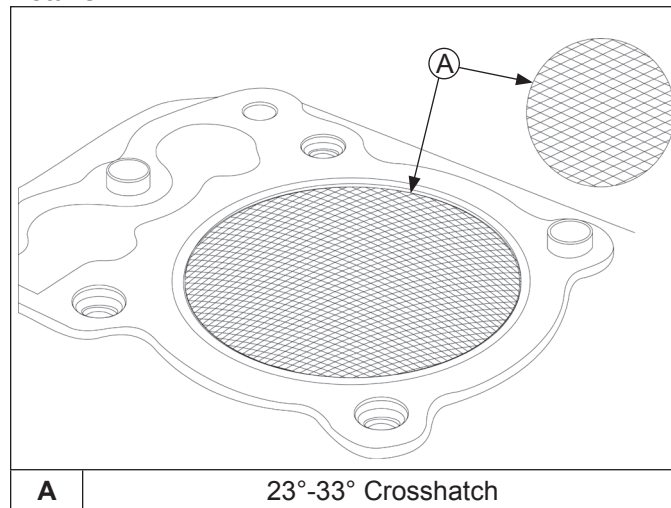

NOTE: Rehlko pistons are custom-machined to exacting tolerances. When over-sizing a cylinder, it should be machined exactly 0.25 mm (0.010 in.) over new diameter (refer to Specifications). Oversize Rehlko replacement piston will then fit correctly.

While most commercially available cylinder hones can be used with either portable drills or drill presses, use of a low speed drill press is preferred as it facilitates more accurate alignment of bore in relation to crankshaft crossbore. Honing is best accomplished at a drill speed of about 250 RPM and 60 strokes per minute. After installing coarse stones in hone, proceed as follows:

1. Lower hone into bore and after centering, adjust so stones are in contact with cylinder wall. Use of a commercial cutting-cooling agent is recommended.
2. With lower edge of each stone positioned even with lowest edge of bore, start drill and honing process. Move hone up and down while resizing to prevent formation of cutting ridges. Check size frequently.

- When bore is within 0.064 mm (0.0025 in.) of desired size, remove coarse stones and replace them with burnishing stones. Continue with burnishing stones until bore is within 0.013 mm (0.0005 in.) of desired size and then use finish stones (220-280 grit) and polish bore to its final size. A crosshatch should be observed if honing is done correctly. Crosshatch should intersect at approximately 23°-33° off horizontal. Too flat an angle could cause rings to skip and wear excessively, and too steep an angle will result in high oil consumption.
- After resizing, check bore for roundness, taper, and size. Use an inside micrometer, telescoping gauge, or bore gauge to take measurements. These measurements should be taken at 3 locations in cylinder – at top, middle, and bottom. Two measurements should be taken (perpendicular to each other) at 3 locations.

Clean Cylinder Bore After Honing

Proper cleaning of cylinder walls following boring and/or honing is very critical to a successful overhaul. Machining grit left in cylinder bore can destroy an engine in less than 1 hour of operation after a rebuild.

Final cleaning operation should always be a thorough scrubbing with a brush and hot, soapy water. Use a strong detergent capable of breaking down machining oil while maintaining a good level of suds. If suds break down during cleaning, discard dirty water and start again with more hot water and detergent. Following scrubbing, rinse cylinder with very hot, clear water, dry it completely, and apply a light coating of engine oil to prevent rusting.

Measuring Piston-to-Bore Clearance

Piston Detail

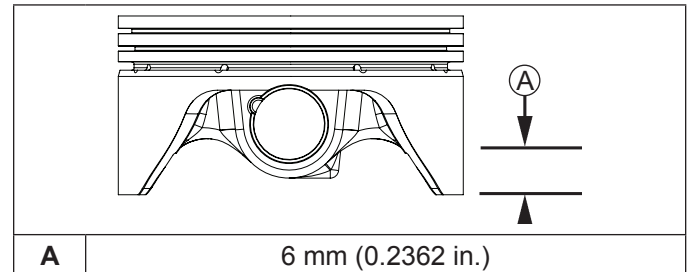

NOTE: Do not use a feeler gauge to measure piston-to-bore clearance, it will yield inaccurate measurements. Always use a micrometer.

Before installing piston into cylinder bore, it is necessary that clearance be accurately checked. This step is often overlooked, and if clearances are not within specifications, engine failure will usually result.

Use following procedure to accurately measure piston-to-bore clearance:

- Use a micrometer and measure diameter of piston 6 mm (0.2362 in.) above bottom of piston skirt and perpendicular to piston pin.
- Use an inside micrometer, telescoping gauge, or bore gauge and measure cylinder bore. Measurement approximately 63.5 mm (2.5 in.) below top of bore and perpendicular to piston pin.
- Piston-to-bore clearance is difference between bore diameter and piston diameter (step 2 minus step 1).

Reassembly

NOTE: Make sure engine is assembled using all specified torque values, tightening sequences, and clearances. Failure to observe specifications could cause severe engine wear or damage. Always use new gaskets.

Make sure all traces of any cleaner are removed before engine is assembled and placed into operation. Even small amounts of these cleaners can quickly break down lubricating properties of engine oil.

Check oil pan, crankcase, cylinder heads, and valve covers to be certain all old sealing material has been removed. Use gasket remover, lacquer thinner, or paint remover to remove any remaining traces. Clean surfaces with isopropyl alcohol, acetone, lacquer thinner, or electrical contact cleaner.

Connecting Rods/Piston/Breather Components

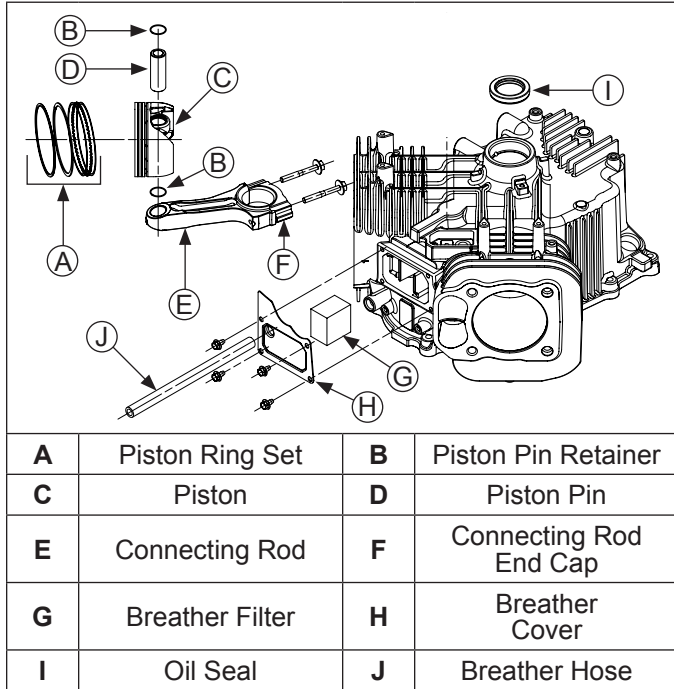

Install Flywheel End Oil Seal

1. Make sure seal bore of crankcase is clean and free of any nicks or burrs.
2. Apply a light coat of P80 Emulsion Lubricant (refer to Tools and Aids) to outside diameter of oil seal.
3. Install oil seal into crankcase using a seal driver. Make sure oil seal is installed straight and true in bore and tool bottoms against crankcase.

Install Breather Filter and Breather Cover

Fastener Torque Sequence and Sealant

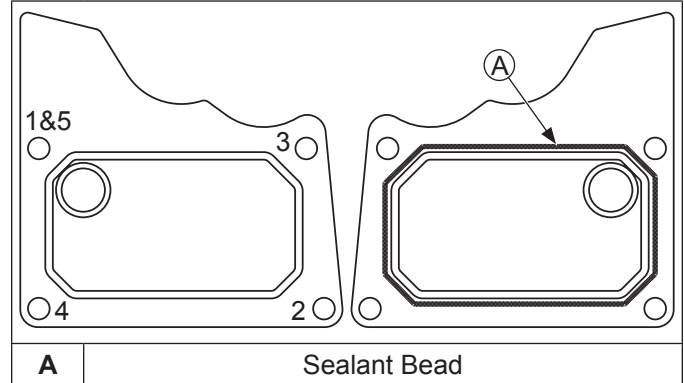

NOTE: Always use fresh sealant. Using outdated sealant can result in leakage. Refer to Tools and Aids for a listing of approved sealants.

NOTE: To ensure proper adhesion of sealant to both sealing surfaces, perform step 4 immediately (5 minutes maximum) after application of RTV.

NOTE: RTV sealant should be allowed to cure a minimum of 1 hour before engine is started.

1. Install breather filter between 2 ribs inside breather chamber.
2. Make sure sealing surfaces are clean and free of nicks or damage.
3. Apply a 1.5 mm (1/16 in.) bead of RTV sealant to sealing surface of breather cover. See sealant pattern.
4. Immediately install cover onto crankcase. Do not allow RTV sealant to come into contact with any other components.
5. Secure breather cover with M5 screws. Torque screws in sequence shown to 6.2 N·m (55 in. lb.) into a new, cored hole, or 4.0 N·m (35 in. lb.) into a used hole.
6. Attach breather hose if disconnected earlier.

Crankshaft/Governor Gear/Oil Pump Components

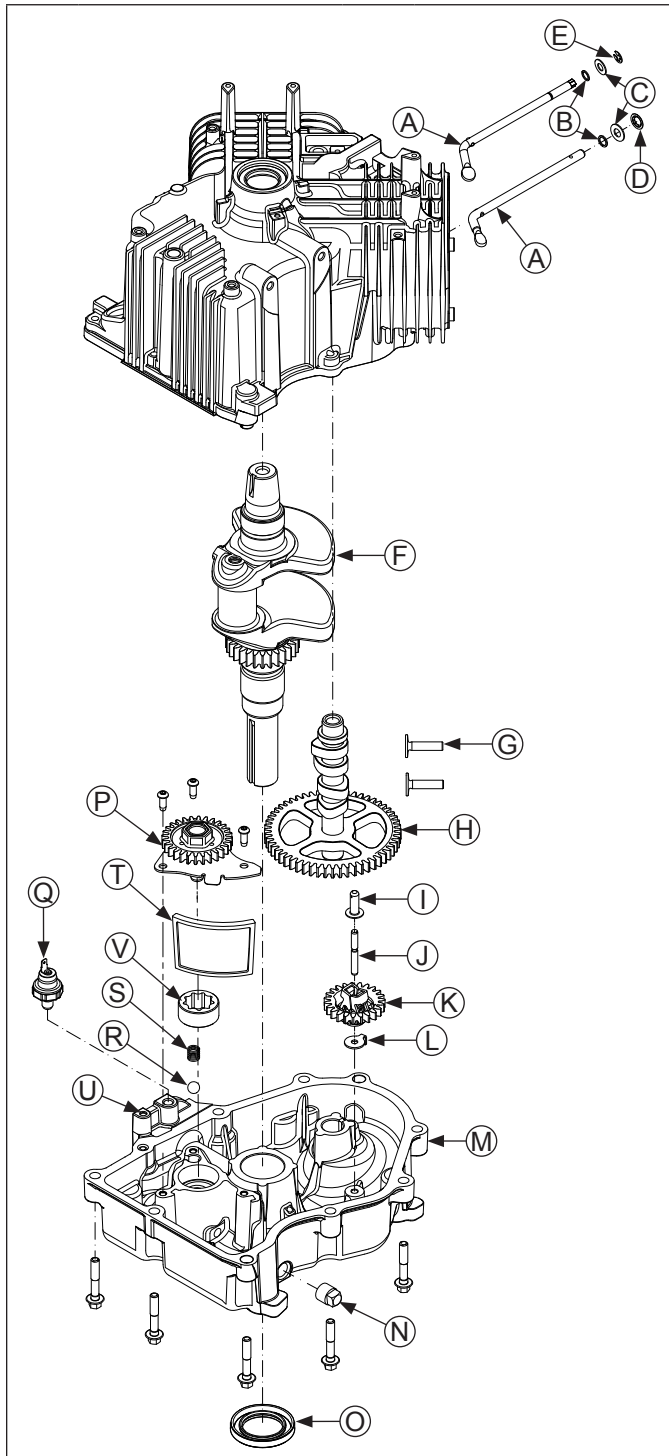

K	Governor Gear	L	Locking Tab Thrust Washer
M	Oil Pan	N	Drain Plug
O	Oil Seal	P	Oil Pump
Q	Oil Sentry™	R	Ball
S	Spring	T	Oil Pick-up Screen
U	Ground Strap Location	V	Outer Gerotor Gear

Install Governor Cross Shaft

1. Lubricate governor cross shaft bearing surfaces in crankcase with engine oil.
2. Slide lower washer onto governor cross shaft and install cross shaft from inside of crankcase.
3. **Round Cross Shaft End:** Install nylon washer onto governor cross shaft, then start push-on retaining ring. Hold cross shaft up in position, place a 0.50 mm (0.020 in.) feeler gauge on top of nylon washer, and push retaining ring down shaft to secure. Remove feeler gauge, which will have established proper end play.

7 mm Hex Cross Shaft End: Install nylon washer onto governor cross shaft. Install E-clip into groove on cross shaft. Use a 0.25 mm (0.010 in.) feeler gauge to make sure gap between washer and clip is at least 0.25 mm (0.010 in.).

Install Crankshaft

1. Lubricate flywheel side main bearing surface and lips of oil seal in crankcase with clean engine oil.
2. Carefully slide flywheel end of crankshaft through main bearing in crankcase.

A	Governor Cross Shaft	B	Lower Washer
C	Nylon Washer	D	Push-on Retaining Ring
E	E-Clip	F	Crankshaft
G	Valve Tappets	H	Camshaft
I	Regulating Pin	J	Shaft

Reassembly

Install Connecting Rods with Pistons and Rings

Piston and Connecting Rod Details

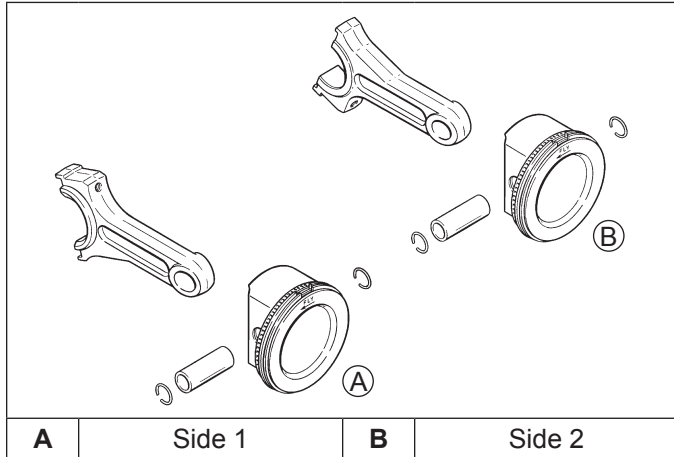

Connecting Rod Screw Details

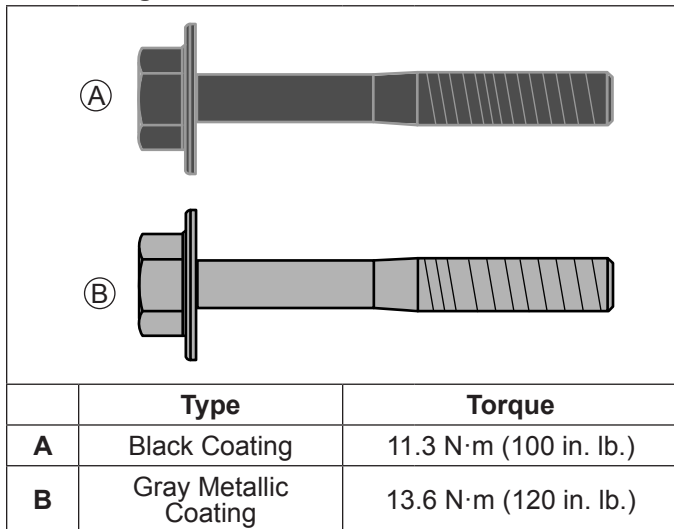

NOTE: Cylinders are numbered on crankcase. Make sure to install piston, connecting rod, and end cap into its appropriate cylinder bore as previously marked during disassembly. Do not mix end caps and connecting rods.

NOTE: Proper orientation of piston/connecting rod assemblies inside engine is extremely important. Improper orientation can cause extensive wear or damage. Be certain pistons and connecting rods are assembled exactly as shown.

NOTE: Align chamfer of connecting rod with chamfer of its mating end cap. When installed, flat faces of connecting rods should face each other. Faces with raised rib should be toward outside.

1. Stagger piston rings in grooves until end gaps are 120° apart. Oil ring rails should also be staggered.
2. Lubricate cylinder bore, piston, and piston rings with engine oil. Compress rings using a piston ring compressor.
3. Lubricate crankshaft journals and connecting rod bearing surfaces with engine oil.

4. Make sure FLY stamping on piston is facing toward flywheel side of engine. Use a hammer with a rubber or wood grip and gently tap piston into cylinder. Be careful oil ring rails do not spring free between bottom of ring compressor and top of cylinder.
5. Install inner rod cap to connecting rod using screws. Two different types of coatings on connecting rod screws have been used. If black coating, torque in increments to 11.3 N·m (100 in. lb.). If gray metallic coating, it is not necessary to lubricate this screw, torque in increments to 13.6 N·m (120 in. lb.). Illustrated instructions are provided in service rod package.
6. Repeat above procedure for other connecting rod and piston assembly.

Install Valve Tappets and Camshaft

NOTE: Exhaust valve tappets are located on output shaft side of engine, while intake valve tappets are located on fan side of engine. Cylinder number is embossed on outside of each cylinder on crankcase. Valve tappets should always be installed in same position as before disassembly.

1. Apply camshaft lubricant to contact surface of valve tappets. Note mark or tag identifying tappets and install them in their appropriate crankcase locations. A small amount of grease applied to stems will hold valve tappets up until camshaft is installed.
2. Liberally apply camshaft lubricant to lobes of camshaft. Lubricate camshaft bearing surfaces of crankcase and camshaft with engine oil.
3. Position timing mark of crankshaft gear at 12 o'clock position.
4. Turn governor cross shaft clockwise until lower end (blade) is laying against bottom of cylinder. Make sure cross shaft remains in this position while installing camshaft.
5. Slide camshaft into bearing surface of crankcase, positioning timing mark of camshaft gear at 6 o'clock position. Make sure camshaft gear and crankshaft gear mesh with both timing marks aligned.

Oil Pump Assembly

Oil pump is mounted inside oil pan. If service was required and oil pump was removed, refer to Disassembly/Inspection and Service procedure.

Governor Assembly

Governor assembly is located inside oil pan. If service was required and governor was removed, refer to Disassembly/Inspection and Service procedure.

Install Oil Seal in Oil Pan

Oil Seal Component and Detail

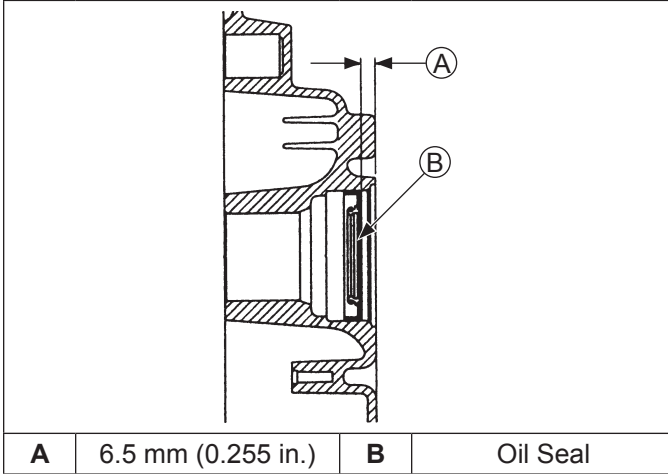

1. Check to make sure there are no nicks or burrs in crankshaft bore of oil pan.
2. Apply a light coat of P80 Emulsion Lubricant (refer to Tools and Aids) to outside diameter of oil seal.
3. Drive oil seal into oil pan using a seal driver. Make sure oil seal is installed straight and true in bore, to depth shown.

Install Oil Pan Assembly

Sealant Pattern

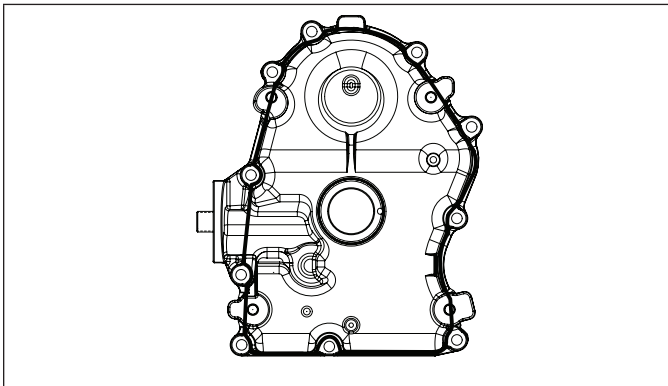

Fastener Torque Sequence

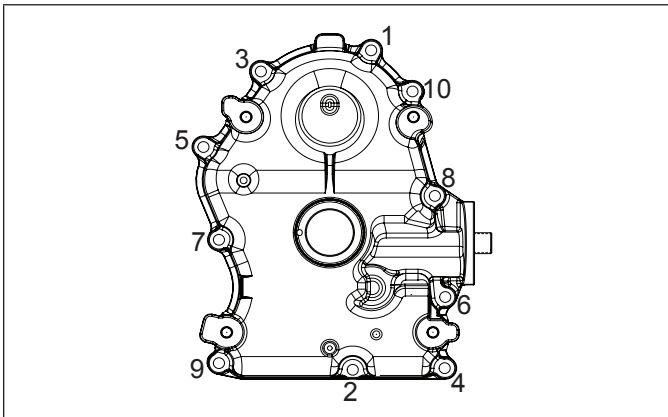

RTV sealant is used as a gasket between oil pan and crankcase. Refer to Tools and Aids for a listing of approved sealants. Always use fresh sealant. Using outdated sealant can result in leakage.

1. Be sure sealing surfaces have been cleaned and prepared as described at beginning of Reassembly.
2. Check to make sure there are no nicks or burrs on sealing surfaces of oil pan or crankcase.
3. Apply a 1.5 mm (1/16 in.) bead of black RTV sealant to sealing surface of oil pan. See sealant pattern. Oil pan must be installed within 5 minutes of sealant being applied for proper sealing to occur.
4. Make sure end of governor cross shaft is lying against bottom of cylinder inside crankcase.
5. Install oil pan to crankcase. Carefully seat camshaft with shim and crankshaft into their mating bearings. Rotate crankshaft to help engage oil pump and governor gear meshes.
6. Install 10 screws securing oil pan to crankcase. Torque fasteners in sequence shown to 24.4 N·m (216 in. lb.).

Reassembly

Flywheel/Ignition/Breather Components

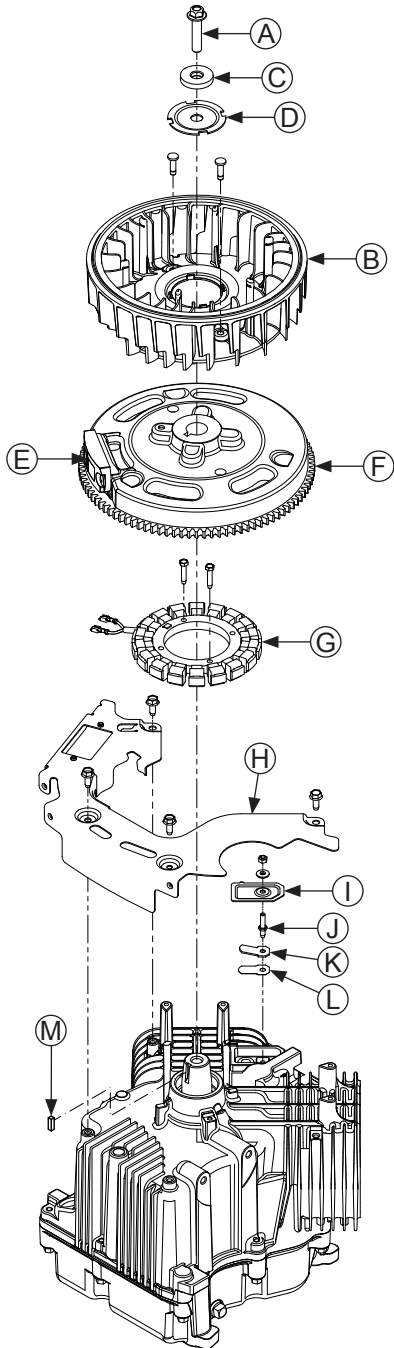

A	Flywheel Screw	B	Fan
C	Washer	D	Fan Mounting Plate
E	Magnet	F	Flywheel
G	Stator	H	Backing Plate
I	Breather Reed Cover	J	Stud
K	Retainer	L	Breather Reed
M	Flywheel Key		

Install Breather Reed and Breather Reed Cover

Breather Reed Cover Sealant

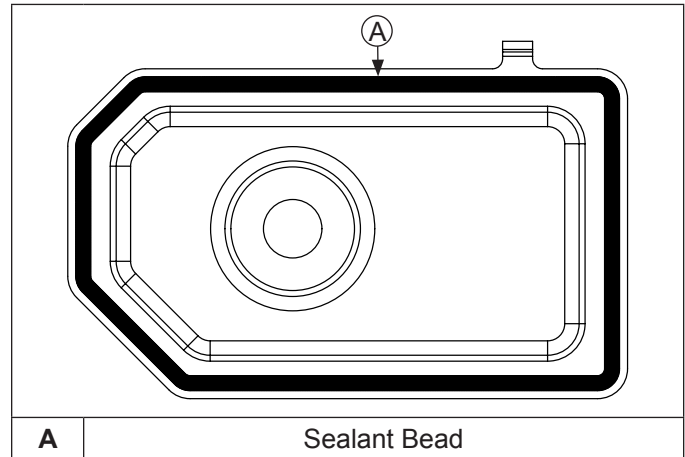

NOTE: RTV sealant should be allowed to cure a minimum of 1 hour before engine is started.

1. Install breather reed, followed by retainer over passage hole and mounting hole in crankcase. Hold in position and secure with mounting stud. Torque stud to 6.2 N·m (55 in. lb.) into a new, cored hole, or 4.0 N·m (35 in. lb.) into a used hole.
2. Invert breather reed cover and apply a 1.5 mm (1/16 in.) bead of RTV sealant to perimeter flange of cover as shown. Use Loctite® 5900™ or 5910™.
3. Immediately install breather reed cover over mounting stud and onto crankcase. Do not allow RTV sealant to come in contact with breather reed, or reed sealing surface.
4. Secure with a new sealing washer and M5 nut. Torque nut to 1.3 N·m (12 in. lb.). Check that a complete seal has occurred by RTV sealant being squeezed out around entire flange perimeter.

Install Stator and Backing Plate

1. Apply pipe sealant with Teflon® (Loctite® PST® 592™ or equivalent) to stator mounting holes.
2. Position stator aligning mounting holes so leads are at bottom, toward crankcase.
3. Install and torque screws to 8.8 N·m (78 in. lb.).
4. Install backing plate. Secure with screws. Torque screws in a crisscross pattern to 7.3 N·m (65 in. lb.).

Install Flywheel and Fan

	CAUTION
	Damaging Crankshaft and Flywheel can cause personal injury.
Using improper procedures can lead to broken fragments. Broken fragments could be thrown from engine. Always observe and use precautions and procedures when installing flywheel.	

NOTE: Before installing flywheel, make sure crankshaft taper and flywheel hub are clean, dry, and completely free of lubricants. Presence of lubricants can cause flywheel to be overstressed and damaged when screw is torqued to specifications.

NOTE: Make sure flywheel key is installed properly in keyway. Flywheel can become cracked or damaged if key is not installed properly.

1. Install flywheel key into keyway of crankshaft. Make sure key is properly seated and parallel with shaft taper.
2. Install flywheel onto crankshaft being careful not to shift flywheel key.
3. Install fan onto flywheel, so locating pins fit into corresponding recesses. Drive 2 retainers down completely.
4. Install fan mounting plate onto fan, aligning 4 cutouts, followed by heavy flat washer and screw.
5. Use a flywheel strap wrench or holding tool to hold flywheel. Torque screw securing flywheel to crankshaft to 74.5 N·m (55 ft. lb.).

Cylinder Head Components

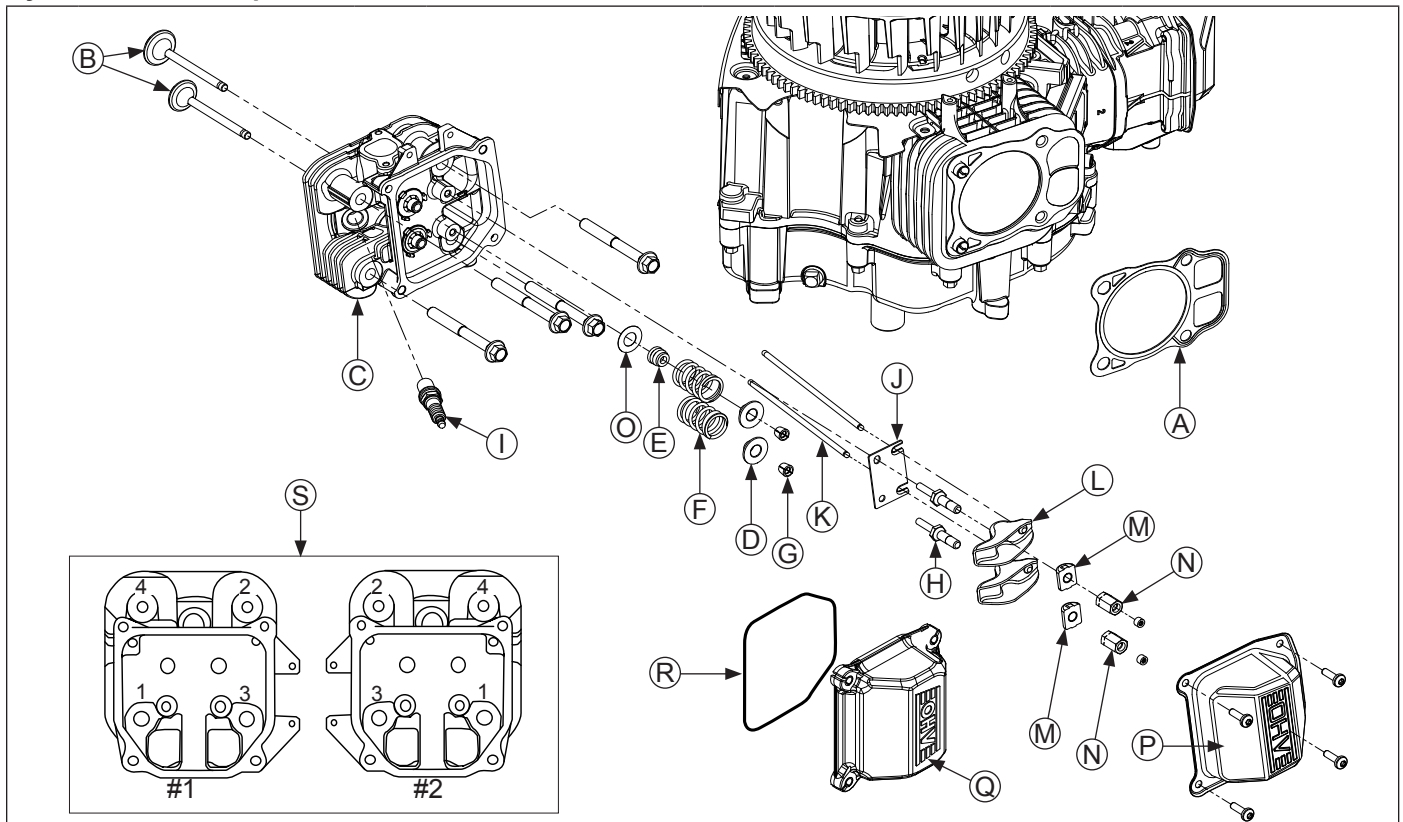

A	Gasket	B	Valve	C	Cylinder Head	D	Valve Spring Cap
E	Valve Stem Seal	F	Valve Spring	G	Valve Spring Keeper	H	Stud
I	Spark Plug	J	Guide Plate	K	Push Rod	L	Rocker Arm
M	Rocker Arm Pivots	N	Adjusters	O	Washer	P	Stamped Steel Valve Cover (RTV)
Q	Plastic Valve Cover (O-Ring)	R	O-Ring	S	Torque Sequence		

Reassembly

Assemble and Install Cylinder Heads

Valve Stem Seals

Use a new seal whenever valve is removed, or if seal is deteriorated or damaged. Never reuse an old seal.

Assemble Cylinder Heads

Prior to installation, lubricate all components with engine oil, paying particular attention to lip of valve stem seal, valve stems, and valve guides. Install following items in order listed below using a valve spring compressor.

- Intake and exhaust valves.
- Valve stem seal.
- Washer (intake valve only).
- Valve springs.
- Valve spring caps.
- Valve spring keepers.

Install Cylinder Heads

NOTE: Match numbers embossed on cylinder heads and crankcase.

NOTE: Push rods should always be installed in same position as before disassembly.

1. Check to make sure there are no nicks or burrs on sealing surfaces of cylinder head or crankcase. Make sure dowel locating pins are in lower 2 cylinder bolt holes on each side.
2. Install a new cylinder head gasket (with printing up) on each side.
3. Install each cylinder head and start 4 screws.
4. Torque screws in 2 stages; first to 22.6 N·m (200 in. lb.), then finally to 41.8 N·m (370 in. lb.), following sequence.

Install Rocker Arms

1. Note mark or tag identifying push rod as either intake or exhaust and cylinder 1 or 2. Check each push rod is straight and not bent. Dip ends of push rods in engine oil and install in their original positions, making sure each push rod ball seats in its tappet socket.
2. Install guide plate and studs. Torque studs to 11.3 N·m (100 in. lb.).
3. Apply grease to contact surfaces of adjusters, rocker arms and rocker arm pivots. Install rocker arms and rocker arm pivots onto appropriate cylinder head, and install adjuster finger tight. Make sure set screw is backed out until flush with adjuster.

Adjust Valve Clearance

Adjusters Retaining Push Rods

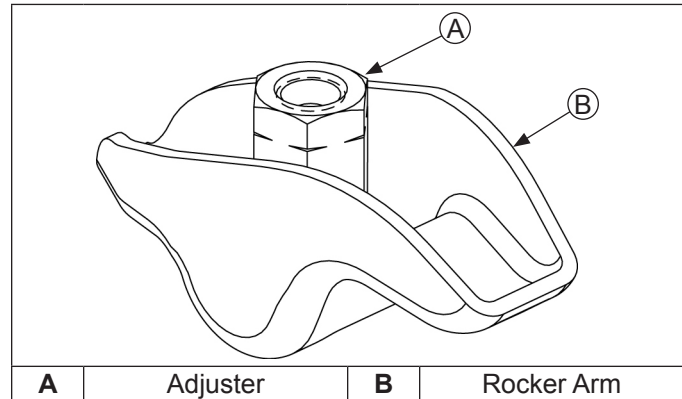

1. Rotate crankshaft to establish TDC on compression stroke for cylinder 1.
Check for:
 - a. Compression will be felt through spark plug hole.
 - b. Keyway of crankshaft will be aligned with cylinder 1.
 - c. No rocker arm/push rod movement if crankshaft is rotated slightly back and forth. If they are moving, rotate crankshaft 1 full revolution.
2. Insert a 0.127 mm (0.005 in.) feeler gauge between end of 1 valve and rocker arm. Turn adjuster until a slight drag is felt. Hold in this position and tighten setscrew securely. Torque setscrew to 7.9 N·m (70 in. lb.). After tightening recheck adjustment. Proper valve clearance is 0.101/0.152 mm (0.004/0.006 in.).
3. Repeat procedure for other valve on side 1.
4. Viewed from PTO end, rotate crankshaft 270° (3/4 turn) counterclockwise and align crankshaft keyway with cylinder 2, which now puts cylinder at TDC on compression stroke.
5. Repeat steps 3-4 for setting valve clearance on side 2.
6. Rotate crankshaft to check for free operation of valve train. Check for clearance between valve spring coils at full lift, or bending of push rod(s) can occur. Minimum allowable clearance is 0.25 mm (0.010 in.).

Check Assembly

Rotate crankshaft a minimum of 2 revolutions to check lockblock assembly and overall proper operation.

Install Valve Covers

Plastic valve covers contain integral bolt hole spacers molded in place. Sealing of plastic valve covers is accomplished using a yellow colored O-ring. In stamped steel valve covers sealing is accomplished using RTV sealant.

Plastic Valve Covers

Plastic Valve Cover Torque Sequence

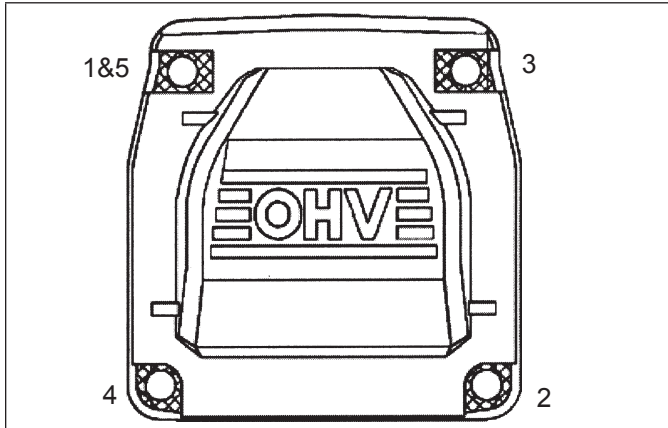

1. Make sure sealing surfaces of valve covers and cylinder heads are clean and free of any nicks or burrs.
2. Install a new O-ring in groove of each cover. Do Not use gaskets or RTV sealant.
3. Position covers on cylinder heads. If a pulse style fuel pump is used, valve cover with pulse fitting hole must be installed on side 2. Install screws in each cover and finger tighten.
4. Using sequence shown, torque valve cover screws to the appropriate torque for style of screw.

	Hex Flange to 9.0 N·m (80 in. lb.)
	Pan Head to 6.2 N·m (55 in. lb.)

Stamped Steel Valve Covers

Stamped Steel Valve Cover RTV Sealant

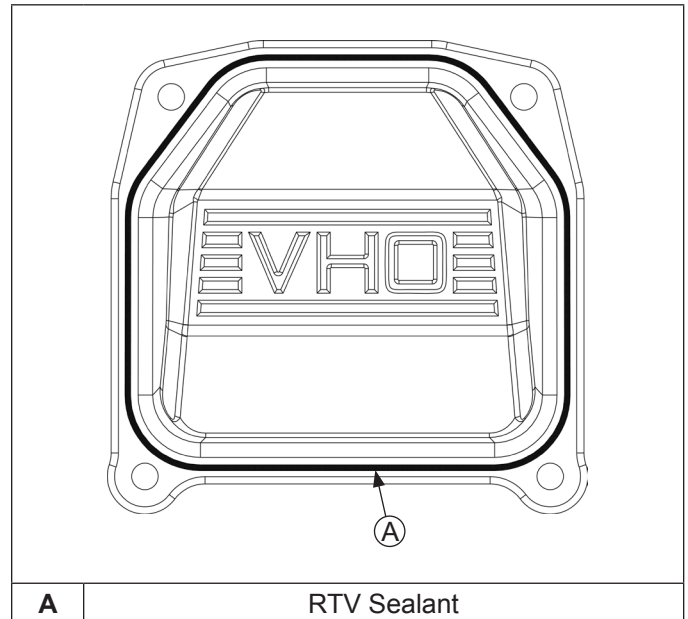

Stamped Steel Valve Cover Torque Sequence

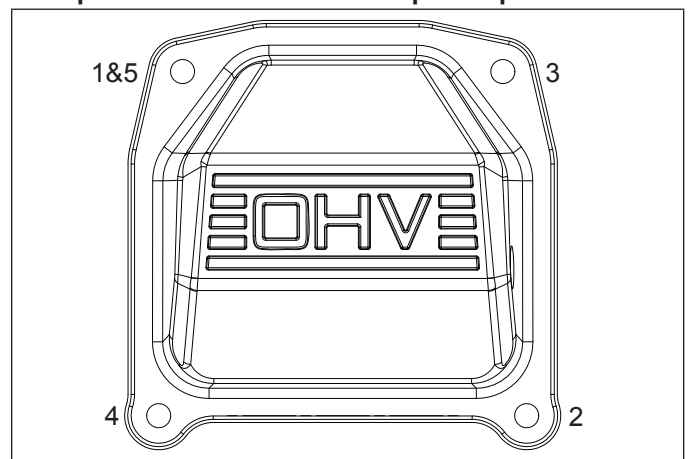

NOTE: Always use fresh sealant. Using outdated sealant can result in leakage. Refer to Tools and Aids for information on sealant dispenser.

NOTE: To ensure proper adhesion of sealant to both sealing surfaces, perform step 3 immediately (5 minutes maximum) after application of RTV.

RTV silicone sealant is used as a gasket between valve cover and cylinder head. Refer to Tools and Aids for a listing of approved sealants.

1. Prepare sealing surfaces of cylinder heads and valve covers. Flatness of sealing surface must be checked prior to reinstallation. See Disassembly.
2. Apply a 1.5 mm (1/16 in.) bead of sealant to valve cover as shown.

Reassembly

3. Position covers on cylinder heads. If a pulse style fuel pump is used valve cover with pulse fitting hole must be installed on side 2. Install screws in each cover and finger tighten.
4. Torque valve cover fasteners to 13.6 N·m (120 in. lb.), using sequence shown.

Install Spark Plugs

1. Check gap using wire feeler gauge. Adjust gap to 0.76 mm (0.030 in.).
2. Install plug into cylinder head.
3. Torque plug to 27 N·m (20 ft. lb.).

External Engine Components

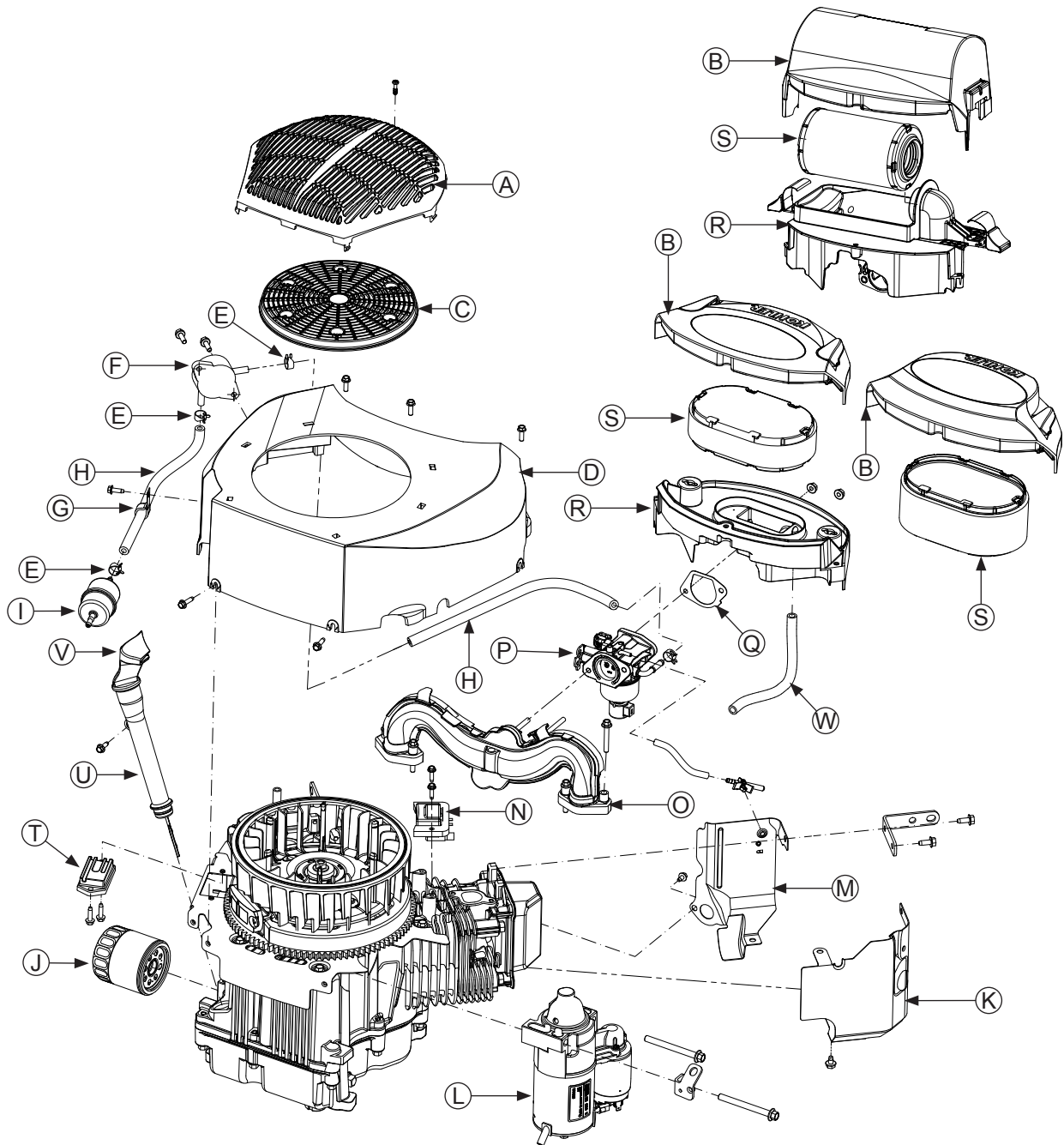

A	Fixed Guard	B	Air Cleaner Cover	C	Debris Screen	D	Blower Housing
E	Hose Clamp	F	Fuel Pump	G	Hose Clip	H	Fuel Line
I	Fuel Filter	J	Oil Filter	K	Outer Baffle	L	Electric Starter
M	Inner Baffle	N	Ignition Module	O	Intake Manifold	P	Carburetor
Q	Gasket	R	Air Cleaner Base	S	Air Cleaner Element	T	Rectifier-Regulator
U	Dipstick Tube	V	Oil Fill/Dipstick	W	Breather Hose		

Reassembly

Install Ignition Modules

Smart-Choke™ Deflector Support Tab

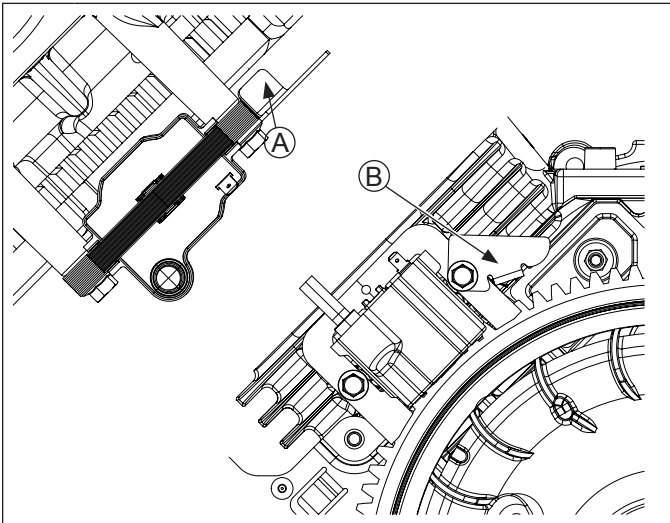

A	Position tab towards crankcase.
B	Rotate tab against module before tightening.

NOTE: On some early production engines equipped with Smart-Choke™, make sure to install deflector support tab on #2 cylinder ignition module.

1. Rotate flywheel to position magnet away from ignition module bosses.
2. CDI modules are installed on cylinder 1 with single kill tab away from cylinder/towards you, and on cylinder 2 with single kill tab towards cylinder/away from you.
MDI modules are installed with flat side out/towards you.
3. Install each ignition module to crankcase bosses. Slide modules up as far away from flywheel as possible and snug screws to hold them in position.
4. Rotate flywheel to position magnet directly under 1 ignition module.
5. Insert a 0.25 mm (0.009 in.) flat feeler gauge between magnet and ignition module. Loosen screws enough to allow magnet to pull module down against feeler gauge.
6. Torque screws to 4.0-6.2 N·m (35-55 in. lb.).
7. Repeat steps 4 through 6 for other ignition module.
8. Rotate flywheel back and forth checking for clearance between magnet and ignition modules.
Make sure magnet does not strike modules. Check gap with a feeler gauge and readjust if necessary.
Final air gap 0.203/0.305 mm (0.008/0.012 in.).

Install Intake Manifold

Torque Sequence

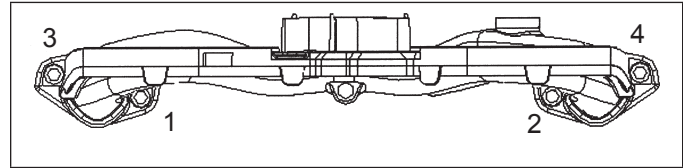

1. On engines equipped with Smart-Choke™, install air vane deflector into intake manifold. Torque screw to 1 N·m (9 in. lb.).
2. Install intake manifold using new O-rings, with wiring harness attached, onto cylinder heads. Slide any wiring harness clips onto appropriate bolts before installing. Using sequence shown, torque screws in 2 increments, first to 7.4 N·m (66 in. lb.), then to 9.9 N·m (88 in. lb.).
3. Connect kill lead to tab terminal on standard ignition modules.

Install Rectifier-Regulator (if equipped)

1. Install B+ terminal/lead into center position of rectifier-regulator plug so it locks in place, and connect plug to rectifier-regulator.
2. Attach rectifier-regulator to opening in backing plate from underside, and secure with mounting screws. Torque screws to 4.0 N·m (35 in. lb.).

Install Inner and Outer Cylinder Baffles

1. Attach outer cylinder baffles and secure with M6 screw (lower cylinder location), and M5 screw into backing plate. Tighten screws as listed following step 2.
2. Attach inner baffles including any lifting straps to cylinder head flanges and to 2 crankcase mounting bosses. Lift strap should be outside outer baffle. Secure with M5 screws. Remaining lower inner baffle mounting screws will be installed later.
Torque baffle mounting screws:
M5 screws: 6.2 N·m (55 in. lb.) into a new cored hole, or 4.0 N·m (35 in. lb.) into a used hole.
M6 screws: 10.7 N·m (95 in. lb.) into a new cored hole, or 7.3 N·m (65 in. lb.) into a used hole.

Install Carburetor



⚠ WARNING

Explosive Fuel can cause fires and severe burns.

Do not fill fuel tank while engine is hot or running.

Gasoline is extremely flammable and its vapors can explode if ignited. Store gasoline only in approved containers, in well ventilated, unoccupied buildings, away from sparks or flames. Spilled fuel could ignite if it comes in contact with hot parts or sparks from ignition. Never use gasoline as a cleaning agent.

1. Install a new carburetor gasket. Make sure all holes align and are open.
2. Install carburetor, throttle linkage and governor lever as an assembly.
3. If carburetor is equipped with a fuel solenoid, connect red (power) lead. Attach eyelet terminal of ground lead to inner top carburetor cover mounting screw.

Install Carburetor with Smart-Choke™

Smart-Choke™ Carburetor Components

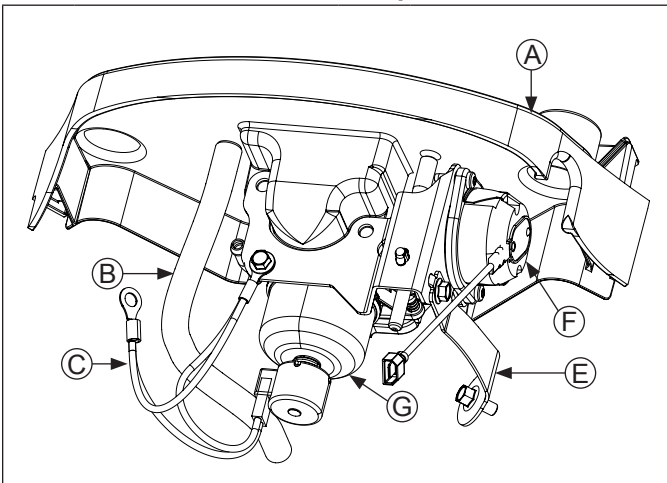

A	Air Cleaner Base	B	Breather Hose
C	Ground Lead	D	Solenoid Lead
E	Smart-Choke™ Bracket Assembly	F	Thermostat
G	Carburetor		

Choke Unloader Linkage

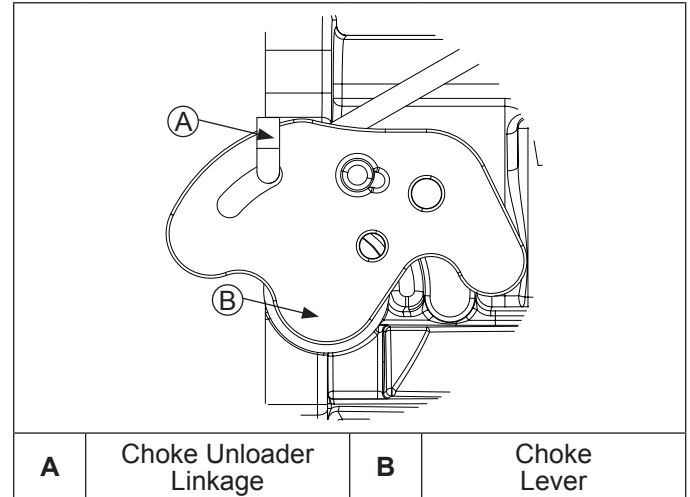

A	Choke Unloader Linkage	B	Choke Lever
----------	------------------------	----------	-------------

Actuator Lever Engaged with Choke Shaft Pin

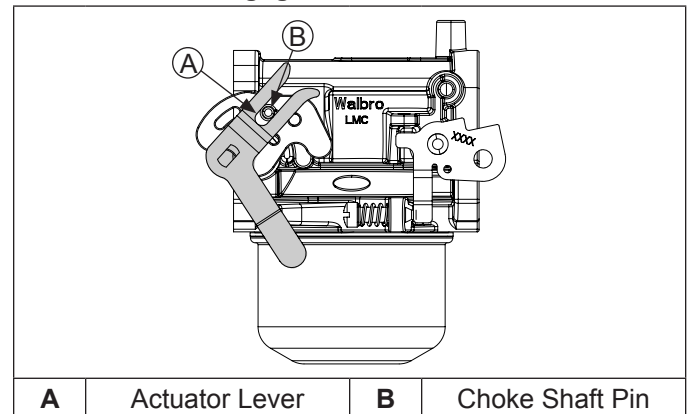

A	Actuator Lever	B	Choke Shaft Pin
----------	----------------	----------	-----------------

NOTE: If thermostat was removed from assembly, refer to procedure in Fuel System section to install.

1. Install new carburetor gasket. Make sure all holes align and are open.
2. Install carburetor, throttle linkage and governor lever as an assembly.
3. Connect choke unloader linkage from air vane deflector to carburetor.
4. If carburetor is equipped with a fuel solenoid, connect red (power) lead. Attach eyelet terminal of ground lead to inner top carburetor cover mounting screw.
5. Install a new air cleaner base gasket and air cleaner base onto mounting studs. Install Smart-Choke™ bracket assembly. Ensure actuator lever is engaged with pin on choke shaft. Torque nuts to 6.2-7.3 N·m (55-65 in. lb.)
6. Connect breather hose to air cleaner base and secure with clamp.

Reassembly

Install Carburetor with eChoke™

eChoke™ Carburetor Components

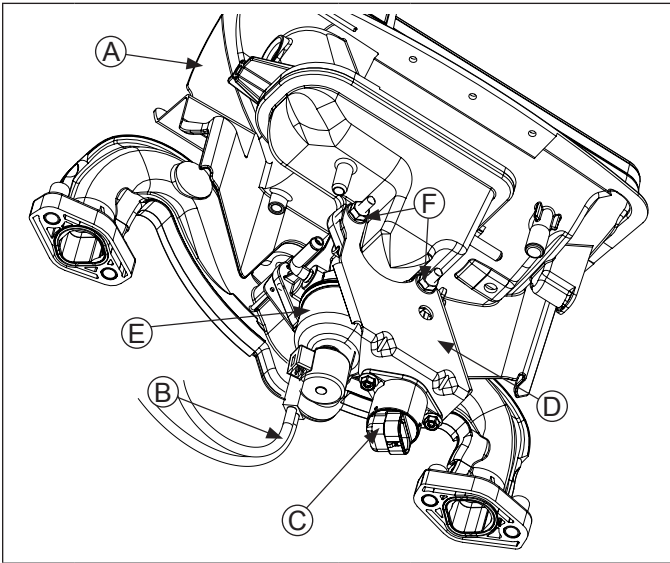

A	Air Cleaner Base	B	Solenoid Lead
C	Stepper Motor	D	eChoke™ Bracket Assembly
E	Carburetor	F	Nuts

NOTE: On engines equipped with eChoke™ stepper motor has a special retract routine that can be activated to ensure motor is in correct position prior to removal or upon replacement of stepper motor when a problem is shown to exist with stepper motor assembly and carburetor. Activation of this routine will occur by initiating three (3) consecutive Key On–Off cycles. Every Key On and Off should be > 2 seconds and < 3.5 seconds. Note that if no other connections are disturbed, stepper motor will be repositioned at next key ON and master module will go back to normal choke operation mode.

1. Install a new carburetor gasket. Make sure all holes align and are open.
2. Install carburetor, throttle linkage and governor lever as an assembly.
3. If carburetor is equipped with a fuel solenoid, connect red (power) lead. Attach eyelet terminal of ground lead to inner top carburetor cover mounting screw.
4. Install a new air cleaner base gasket and air cleaner base onto mounting studs. Install eChoke™ bracket assembly. Connect eChoke™ stepper motor harness and follow routine indicated in NOTE in this section prior to setting link.
5. Connect choke linkage to choke actuator lever on main control bracket assembly. Torque nuts to 6.2-7.3 N·m (55-65 in. lb.).
6. Connect breather hose to air cleaner base and secure with clamp.

Install External Governor Controls

Control Bracket Components

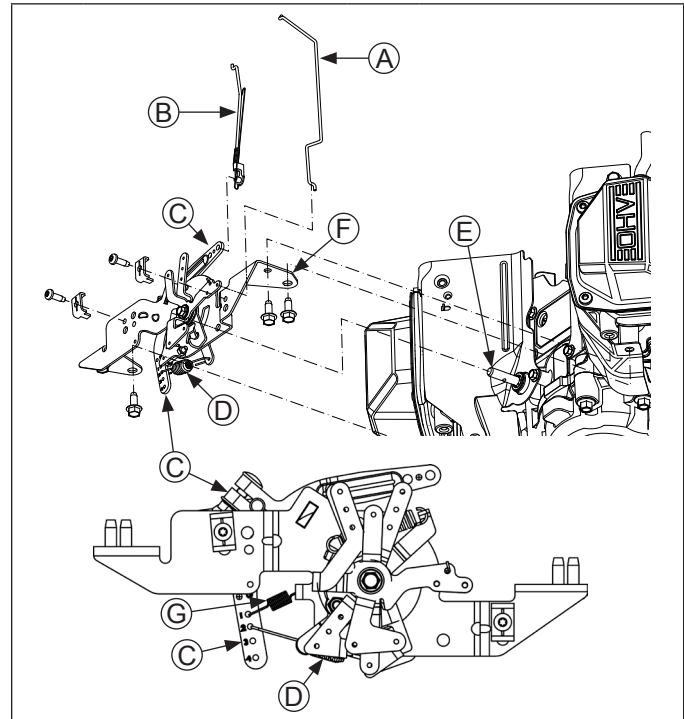

A	Choke Linkage	B	Throttle Linkage
C	Governor Lever	D	Governor Spring
E	Cross Shaft	F	Control Bracket
G	Dampener Spring		

Throttle and Choke Components

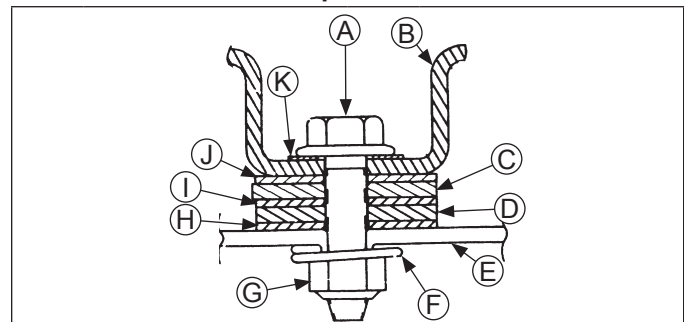

A	Screw	B	Choke Lever
C	Throttle Lever	D	Throttle Actuator Lever
E	Control Bracket	F	Choke Return Spring
G	Lock Nut M5x0.8	H	Shoulder Washer
I	Flat Washer	J	Nylon Washer
K	Wave Washer		

1. Install governor lever onto governor cross shaft if disconnected previously.
2. Make sure throttle linkage is connected to governor lever and throttle lever on carburetor. Connect choke linkage to carburetor choke lever.
3. Attach fuel line to carburetor and secure with a clamp.
4. Install a new air cleaner base gasket and air cleaner base onto mounting studs. Torque nuts to 6.2-7.3 N·m (55-65 in. lb.).
5. Connect breather hose to air cleaner base and secure with clamp.
6. Move governor lever toward carburetor as far as it will go (wide-open throttle), and hold in position.
7. **Round Cross Shaft End:** Insert a nail or similar tool into hole on cross shaft and rotate shaft counterclockwise as far as will turn, then torque nut to 6.8 N·m (60 in. lb.).

7 mm Hex Cross Shaft End: Use 7 mm hex socket on end of cross shaft and rotate shaft counterclockwise (viewed from end) as far as it will turn, then torque nut to 6.8 N·m (60 in. lb.).

Install Air Cleaner Element

Install air cleaner element (with precleaner if equipped), onto air cleaner base.

Install Throttle and Choke Controls

Governor Lever Hole Position

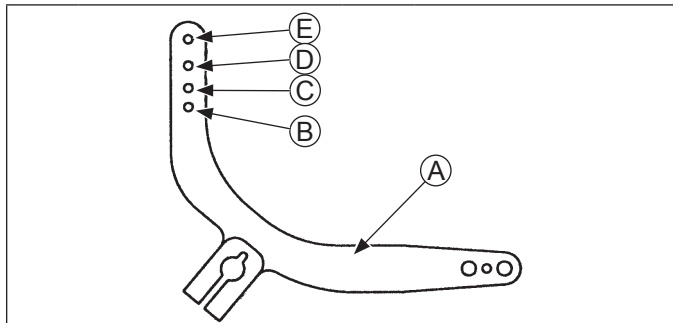

A	Governor Lever	B	Hole 1
C	Hole 2	D	Hole 3
E	Hole 4		

1. Connect choke linkage to choke actuator lever on main control bracket assembly.
2. Install main control bracket to cylinder heads using screws. Two lower screws should also secure inner baffles. Torque screws to 10.7 N·m (95 in. lb.) into new holes, or 7.3 N·m (65 in. lb.) into used holes.
3. Connect governed idle spring to governor lever and main control bracket. Connect governor spring from throttle control bracket to appropriate hole in governor lever.

Install Electric Starter Motor

1. Install starter motor and lift bracket.
2. Torque screws to 23.8 N·m (211 in. lb.).
3. On models with a solenoid shift starter, connect leads to solenoid.

Install Debris Screen

Snap screen onto fan.

Install Blower Housing

NOTE: Do not completely tighten screws until all are installed to allow shifting for hole alignment.

1. Install blower housing onto engine. Start all mounting screws. Make sure wire harness and spark plug leads exit out through appropriate openings in shrouding. Attach any fuel line clamps used.
2. Torque screws as follows:
M5 Blower Housing Screws: 6.2 N·m (55 in. lb.) in a new hole, or 4.0 N·m (35 in. lb.) in a used hole.
M4 HI-LO Screws: 2.8 N·m (25 in. lb.).
M3 HI-LO Screws: 2.3 N·m (20 in. lb.).
3. Install and secure air cleaner cover.

Install Fixed Guard (if equipped)

Install fixed guard. Securely tighten screw (if equipped).

Install Dipstick Tube

1. Lubricate dipstick tube O-ring and install into crankcase.
2. Secure to backing plate using M5 screw.
3. Torque screw to 4.0 N·m (35 in. lb.).

Reassembly

Install Fuel Pump

	⚠ WARNING
	<p>Explosive Fuel can cause fires and severe burns.</p> <p>Do not fill fuel tank while engine is hot or running.</p>
<p>Gasoline is extremely flammable and its vapors can explode if ignited. Store gasoline only in approved containers, in well ventilated, unoccupied buildings, away from sparks or flames. Spilled fuel could ignite if it comes in contact with hot parts or sparks from ignition. Never use gasoline as a cleaning agent.</p>	

Fuel Pump Components

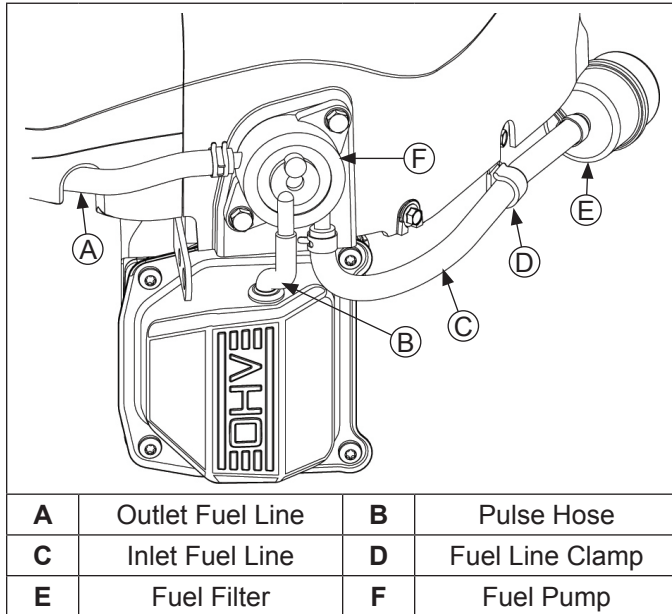

NOTE: If a new fuel pump is being installed, make sure orientation of new pump is consistent with removed pump. Internal damage may occur if installed incorrectly.

1. Connect pulse hose to valve cover. Valve cover should be situated between 2 formed lips on pulse hose.
2. Attach pulse hose to fuel pump and secure with a clamp. Mount fuel pump to blower housing with screws. Torque screws to 2.8 N·m (25 in. lb.).
3. Connect inlet and outlet fuel lines to pump. Route inlet fuel line through fuel line clamp (if used) as shown.

Install Muffler

1. Install muffler and attaching hardware to muffler bracket. Torque screws to 9.9 N·m (88 in. lb.).
2. Install M8 nuts or 5/16-18 head capscrews (based on head design), to secure muffler. Torque hex nuts to 24.4 N·m (216 in. lb.), lock nuts to 27.8 N·m (246 in. lb.), or capscrews to 16.9 N·m (150 in. lb.).

Install Oil Filter and Fill Crankcase with Oil

NOTE: Make sure oil drain plug is installed and torqued to specification to prevent oil leakage.

1. Install oil drain plug. Torque plug to 13.6 N·m (10 ft. lb.).
2. Place new filter in shallow pan with open end up. Fill with new oil until oil reaches bottom of threads. Allow 2 minutes for oil to be absorbed by filter material.
3. Apply a thin film of clean oil to rubber gasket on new filter.
4. Refer to instructions on oil filter for proper installation.
5. Fill crankcase with new oil. Level should be at top of indicator on dipstick.
6. Reinstall oil fill/dipstick and tighten securely.

Connect Spark Plug Leads

Connect leads to spark plugs.

Prepare Engine for Operation

Engine is now completely reassembled. Before starting or operating engine, be sure to do following.

1. Make sure all hardware is tightened securely.
2. Make sure oil drain plug, Oil Sentry™ pressure switch, and a new oil filter are installed.
3. Adjust carburetor idle speed adjusting screw as necessary.

Testing Engine

It is recommended engine be operated on a stand or bench prior to installation in piece of equipment.

1. Run engine at idle for 2-3 minutes, then 5-6 minutes more between idle and midrange.
2. Adjust idle speed screw and high-speed stop as necessary. Make sure maximum engine speed does not exceed 3750 RPM (no load).



1P32 690 03

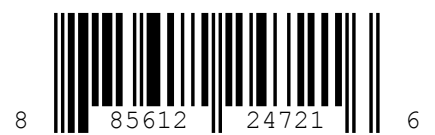

8 85612 24721 6