

Command PRO

CH682, CH732, CH742, CH752

Service Manual

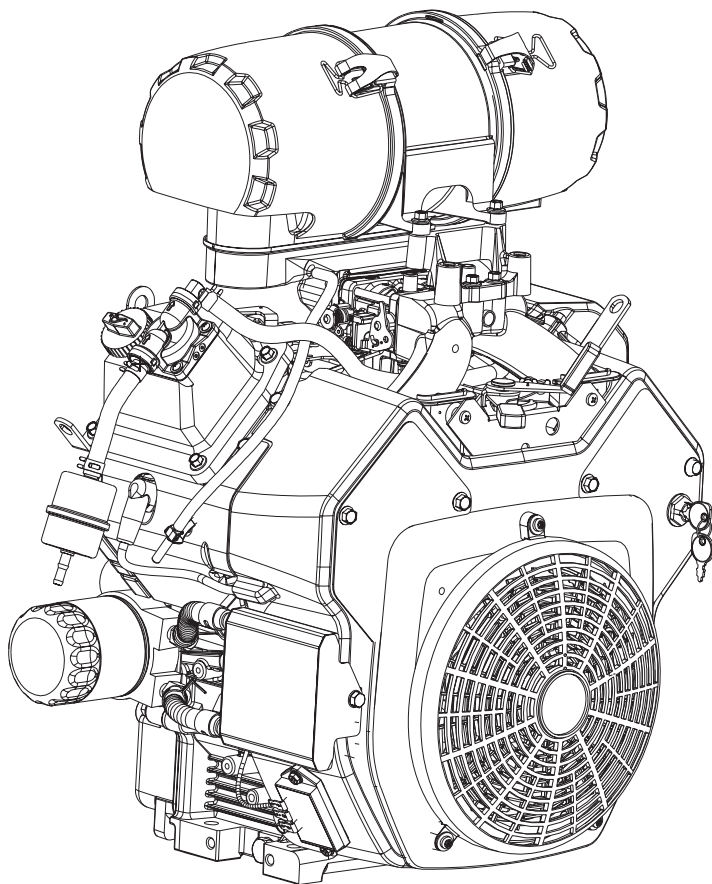

Kohler Engines
is now Rehlko.

2	Safety
3	Maintenance
5	Specifications
13	Tools and Aids
16	Troubleshooting
20	Air Cleaner/Intake
21	Fuel System
27	Governor System
29	Lubrication System
31	Electrical System
38	Starter System
42	Disassembly/Inspection and Service
56	Reassembly

IMPORTANT: Read all safety precautions and instructions carefully before operating equipment. Refer to operating instruction of equipment that this engine powers.

Ensure engine is stopped and level before performing any maintenance or service.

Safety

SAFETY PRECAUTIONS

⚠ WARNING: A hazard that could result in death, serious injury, or substantial property damage.

⚠ CAUTION: A hazard that could result in minor personal injury or property damage.

NOTE: is used to notify people of important installation, operation, or maintenance information.

	⚠ WARNING
	Explosive Fuel can cause fires and severe burns. Do not fill fuel tank while engine is hot or running.
Gasoline is extremely flammable and its vapors can explode if ignited. Store gasoline only in approved containers, in well ventilated, unoccupied buildings, away from sparks or flames. Spilled fuel could ignite if it comes in contact with hot parts or sparks from ignition. Never use gasoline as a cleaning agent.	

	⚠ WARNING
	Rotating Parts can cause severe injury. Stay away while engine is in operation.
Keep hands, feet, hair, and clothing away from all moving parts to prevent injury. Never operate engine with covers, shrouds, or guards removed.	

	⚠ WARNING
	Carbon Monoxide can cause severe nausea, fainting or death. Avoid inhaling exhaust fumes. Never run engine indoors or in enclosed spaces.
Engine exhaust gases contain poisonous carbon monoxide. Carbon monoxide is odorless, colorless, and can cause death if inhaled.	

	⚠ WARNING
	Accidental Starts can cause severe injury or death. Disconnect and ground spark plug lead(s) before servicing.
Before working on engine or equipment, disable engine as follows: 1) Disconnect spark plug lead(s). 2) Disconnect negative (-) battery cable from battery.	

	⚠ WARNING
	Hot Parts can cause severe burns. Do not touch engine while operating or just after stopping.
Never operate engine with heat shields or guards removed.	



	⚠ WARNING
	Cleaning Solvents can cause severe injury or death. Use only in well ventilated areas away from ignition sources.
Carburetor cleaners and solvents are extremely flammable. Follow cleaner manufacturer's warnings and instructions on its proper and safe use. Never use gasoline as a cleaning agent.	

	⚠ CAUTION
	Electrical Shock can cause injury. Do not touch wires while engine is running.

	⚠ CAUTION
	Damaging Crankshaft and Flywheel can cause personal injury.
Using improper procedures can lead to broken fragments. Broken fragments could be thrown from engine. Always observe and use precautions and procedures when installing flywheel.	

	⚠ CAUTION
	Failure to utilize or reassemble debris screen as designed could result in debris screen failure and serious personal injury.

MAINTENANCE INSTRUCTIONS

  	⚠ WARNING	Before working on engine or equipment, disable engine as follows: 1) Disconnect spark plug lead(s). 2) Disconnect negative (-) battery cable from battery.
	Accidental Starts can cause severe injury or death. Disconnect and ground spark plug lead(s) before servicing.	

Normal maintenance, replacement or repair of emission control devices and systems may be performed by any repair establishment or individual; however, warranty repairs must be performed by an authorized dealer.

MAINTENANCE SCHEDULE

Weekly

<ul style="list-style-type: none"> Check air cleaner element. 	Air Cleaner/Intake
--	--------------------

Every 100 Hours or Annually¹

<ul style="list-style-type: none"> Change oil. 	Lubrication System
<ul style="list-style-type: none"> Remove cooling shrouds and clean cooling areas. 	Air Cleaner/Intake
<ul style="list-style-type: none"> Check oil cooler fins, clean as necessary (if equipped). 	Lubrication System

Every 200 Hours

<ul style="list-style-type: none"> Change oil filter. 	Lubrication System
<ul style="list-style-type: none"> Replace fuel filter. 	

Every 250 Hours¹

<ul style="list-style-type: none"> Replace air cleaner element and check inner element. 	Air Cleaner/Intake
--	--------------------

Every 300 Hours³

<ul style="list-style-type: none"> Change oil and filter (Xtended Life PRO 10W-50 oil and Xtended Life Pro filter only). 	Lubrication System
---	--------------------

Every 500 Hours¹

<ul style="list-style-type: none"> Replace air cleaner inner element. 	Air Cleaner/Intake
<ul style="list-style-type: none"> Replace spark plugs and set gap. 	Electrical System

Every 500 Hours²

<ul style="list-style-type: none"> Have crankshaft spline lubricated.
--

¹ Perform these procedures more frequently under severe, dusty, dirty conditions.

² Have an authorized dealer perform this service.

³ Option only if using Xtended Life PRO oil and Xtended Life PRO filter.

REPAIRS/SERVICE PARTS

Rehiko genuine service parts can be purchased from authorized dealers. To find a local authorized dealer visit engines.rehiko.com or call 1-800-544-2444 (U.S. and Canada).

Maintenance

OIL RECOMMENDATIONS

All-season Xtended Life PRO 10W-50 Synthetic Oil is the ideal oil for Rehlko engines. It is specifically formulated to extend the oil and oil filter change interval to 300 Hours when paired with a Xtended Life PRO Extended Life Oil Filter.

300-Hour oil and oil filter change intervals are exclusive to and only authorized on Rehlko engines that utilize both the Xtended Life PRO 10W-50 Synthetic Oil and Xtended Life PRO Oil Filter. Alternative engine oils and oil filters may be used with Rehlko engines but require 100-Hour oil and 200-Hour oil filter change intervals for proper maintenance. Oil must be API (American Petroleum Institute) service class SJ or higher. Select viscosity based on air temperature at time of operation as shown below.

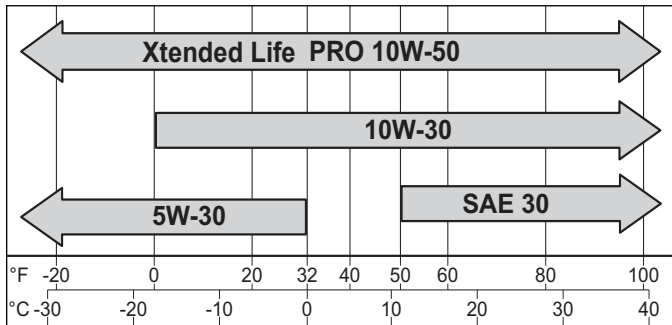

FUEL RECOMMENDATIONS

	⚠ WARNING
	<p>Explosive Fuel can cause fires and severe burns.</p> <p>Do not fill fuel tank while engine is hot or running.</p>
<p>Gasoline is extremely flammable and its vapors can explode if ignited. Store gasoline only in approved containers, in well ventilated, unoccupied buildings, away from sparks or flames. Spilled fuel could ignite if it comes in contact with hot parts or sparks from ignition. Never use gasoline as a cleaning agent.</p>	

NOTE: E15, E20 and E85 are NOT approved and should NOT be used; effects of old, stale or contaminated fuel are not warrantable.

Fuel must meet these requirements:

- Clean, fresh, unleaded gasoline.
- Octane rating of 87 (R+M)/2 or higher.
- Research Octane Number (RON) 90 octane minimum.
- Gasoline up to 10% ethyl alcohol, 90% unleaded is acceptable.
- Methyl Tertiary Butyl Ether (MTBE) and unleaded gasoline blend (max 15% MTBE by volume) are approved.
- Do not add oil to gasoline.
- Do not overfill fuel tank.
- Do not use gasoline older than 30 days.

STORAGE

If engine will be out of service for 2 months or more follow procedure below.

1. Add Xtended Life PRO Series fuel treatment or equivalent to fuel tank. Run engine 2-3 minutes to get stabilized fuel into fuel system (failures due to untreated fuel are not warrantable).
2. Change oil while engine is still warm from operation (NOT required if using Xtended Life PRO 10W-50 full-synthetic oil). Remove spark plug(s) and pour about 1 oz. of engine oil into cylinder(s). Replace spark plug(s) and crank engine slowly to distribute oil.
3. Disconnect negative (-) battery cable.
4. Store engine in a clean, dry place.

Engine Dimensions

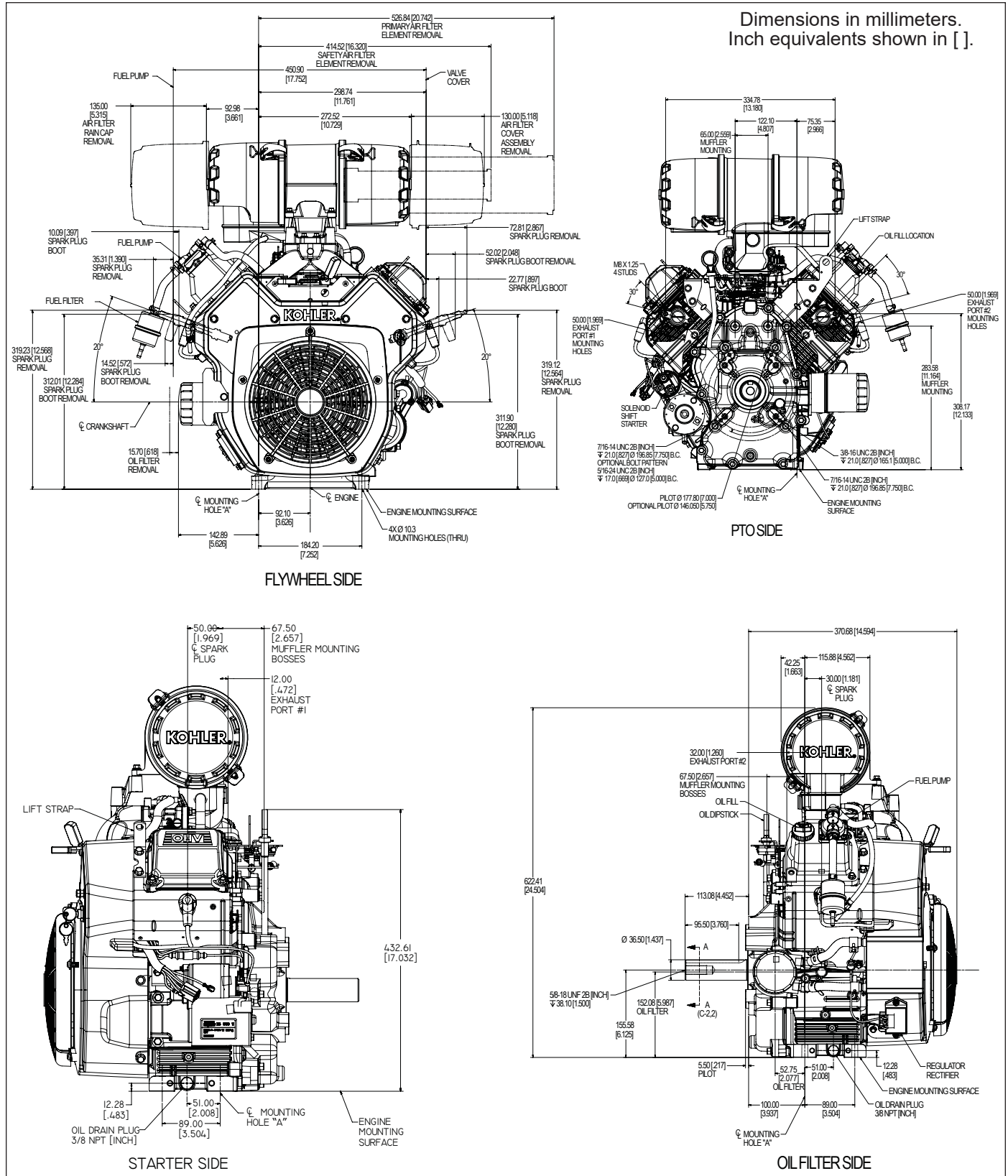

Specifications

ENGINE IDENTIFICATION NUMBERS

Rehiko engine identification numbers (models, specification and serial) should be referenced for efficient repair, ordering correct parts, and engine replacement.

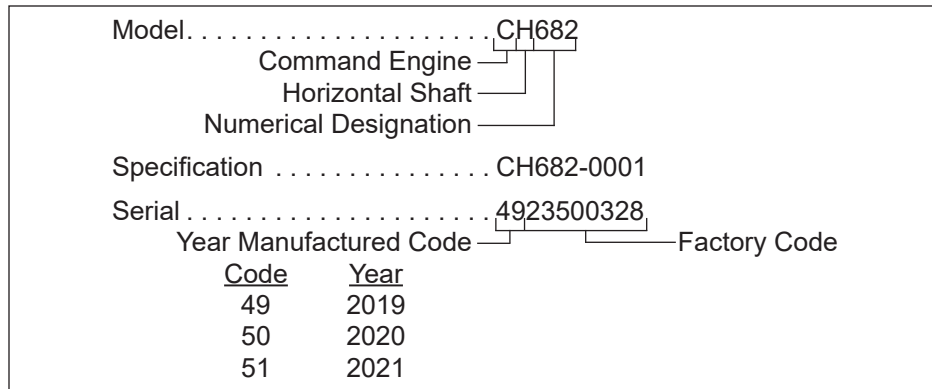

GENERAL SPECIFICATIONS^{4,7}

	CH682	CH732	CH742	CH752
Bore	80 mm (3.15 in.)	83 mm (3.27 in.)		
Stroke	69 mm (2.72 in.)			
Displacement	694 cc (42.4 cu. in.)	747 cc (45.6 cu. in.)		
Oil Capacity (refill)	1.6-1.8 L (1.7-1.9 U.S. qt.)			
Maximum Angle of Operation (@ full oil level) ⁵	25°			

TORQUE SPECIFICATIONS^{4,6}

	CH682	CH732	CH742	CH752
Blower Housing and Sheet Metal				
M5 Fasteners	6.2 N·m (55 in. lb.) into new holes 4.0 N·m (35 in. lb.) into used holes			
M6 Fasteners	10.7 N·m (95 in. lb.) into new holes 7.3 N·m (65 in. lb.) into used holes			
Carburetor, Intake Manifold, and Air Cleaner				
Intake Manifold Mounting Fastener (torque in 2 increments)	first to 7.4 N·m (66 in. lb.) finally to 9.9 N·m (88 in. lb.)			
Adapter (for Heavy-Duty Air Cleaner) Mounting Fastener	9.9 N·m (88 in. lb.)			
Air Cleaner Nut (torque in 2 increments)	first to 7.3 N·m (65 in. lb.) finally to 8.2 N·m (73 in. lb.)			
Closure Plate				
Fastener	24.4 N·m (216 in. lb.)			
Connecting Rod				
Cap Fastener (torque in increments)	13.6 N·m (120 in. lb.)			

⁴ Values are in Metric units. Values in parentheses are English equivalents.

⁵ Exceeding maximum angle of operation may cause engine damage from insufficient lubrication.

⁶ Lubricate threads with engine oil prior to assembly.

⁷ Any and all horsepower (hp) references by Rehiko are Certified Power Ratings and per SAE J1940 & J1995 hp standards. Details on Certified Power Ratings can be found at engines.rehiko.com.

Specifications

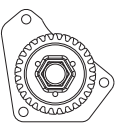
TORQUE SPECIFICATIONS ^{4,6}	CH682	CH732	CH742	CH752
Crankcase				
Breather Cover Fastener	11.3 N·m (100 in. lb.) into new holes 7.3 N·m (65 in. lb.) into used holes			
Oil Drain Plug	13.6 N·m (10 ft. lb.)			
Cylinder Head				
Fastener (torque in 2 increments) Nut	first to 16.9 N·m (150 in. lb.) finally to 35.5 N·m (315 in. lb.)			
Bolt (torque in 2 increments)	first to 22.6 N·m (200 in. lb.) finally to 41.8 N·m (370 in. lb.)			
Rocker Arm Screw Black Screw (M6x1.0x34) Silver Screw (M6x1.0x45)	18.1 N·m (160 in. lb.) 13.6 N·m (120 in. lb.)			
Flywheel				
Fan Fastener	9.9 N·m (88 in. lb.)			
Flywheel Retaining Screw	66.4 N·m (49 ft. lb.)			
Fuel Pump-Pulse				
Fastener	2.3 N·m (20 in. lb.)			
Governor				
Lever Nut	6.8 N·m (60 in. lb.)			
Ignition				
Spark Plug	27 N·m (20 ft. lb.)			
Module Fastener	4.0-6.2 N·m (35-55 in. lb.)			
Rectifier-Regulator Fastener	1.4 N·m (12.6 in. lb.)			
Muffler				
Retaining Nut	24.4 N·m (216 in. lb.)			
Oil Cooler				
Adapter Nipple	27 N·m (20 ft. lb.)			
Oil Pump				
 Oil Pump Style A				
Screw (torque in 2 increments)	10.7 N·m (95 in. lb.) into new hole 6.7 N·m (60 in. lb.) into used holes			
 Oil Pump Style B				
Screw (no torque sequence)	9.0 N·m (80 in. lb.)			

⁴ Values are in Metric units. Values in parentheses are English equivalents.

⁶ Lubricate threads with engine oil prior to assembly.

Specifications

TORQUE SPECIFICATIONS^{4,6}

CH682

CH732

CH742

CH752

Oil Sentry™

Pressure Switch	4.5 N·m (40 in. lb.)
-----------------	----------------------

Solenoid (Starter)

Mounting Hardware	4.0-6.0 N·m (35-53 in. lb.)
Nut, Positive (+) Brush Lead	8.0-11.0 N·m (71-97 in. lb.)

Speed Control Bracket

Fastener	10.7 N·m (95 in. lb.) into new holes 7.3 N·m (65 in. lb.) into used holes
----------	--

Starter Assembly

Thru Bolt	5.6-9.0 N·m (49-79 in. lb.)
Mounting Screw	15.3 N·m (135 in. lb.)
Brush Holder Mounting Screw	2.5-3.3 N·m (22-29 in. lb.)

Stator

Mounting Screw	6.2 N·m (55 in. lb.)
----------------	----------------------

Valve Cover

Yellow O-Ring Style Cover Fastener w/Integral Metal Spacers	9.0 N·m (80 in. lb.)
--	----------------------

CLEARANCE SPECIFICATIONS⁴

CH682

CH732

CH742

CH752

Camshaft

End Play	0.076/0.127 mm (0.0030/0.0050 in.)
Running Clearance	0.025/0.063 mm (0.0010/0.0025 in.)
Bore I.D. New Max. Wear Limit	20.000/20.025 mm (0.7874/0.7884 in.) 20.038 mm (0.7889 in.)
Bearing Surface O.D. New Max. Wear Limit	19.962/19.975 mm (0.7859/0.7864 in.) 19.959 mm (0.7858 in.)

Connecting Rod

Connecting Rod-to-Crankpin Running Clearance New Max. Wear Limit	0.030/0.055 mm (0.0012/0.0022 in.) 0.070 mm (0.0028 in.)
Connecting Rod-to-Crankpin Side Clearance	0.26/0.63 mm (0.0102/0.0248 in.)
Connecting Rod-to-Piston Pin Running Clearance	0.015/0.028 mm (0.0006/0.0011 in.)
Piston Pin End I.D. New Max. Wear Limit	17.015/17.023 mm (0.6699/0.6702 in.) 17.036 mm (0.6707 in.)

Crankcase

Governor Cross Shaft Bore I.D. New Max. Wear Limit	8.025/8.075 mm (0.3159/0.3179 in.) 8.088 mm (0.3184 in.)
--	---

⁴ Values are in Metric units. Values in parentheses are English equivalents.

⁶ Lubricate threads with engine oil prior to assembly.

Specifications

CLEARANCE SPECIFICATIONS ⁴	CH682	CH732	CH742	CH752
Crankshaft				
End Play (free)	0.070/0.590 mm (0.0028/0.0230 in.)			
End Play (w/thrust bearing components)	0.070/1.190 mm (0.0028/0.0468 in.)			
Bore (in crankcase) New Max. Wear Limit	40.965/41.003 mm (1.6128/1.6143 in.) 41.016 mm (1.6148 in.)			
Crankshaft to Sleeve Bearing (crankcase) Running Clearance-New	0.03/0.09 mm (0.0012/0.0035 in.)			
Bore (in closure plate) New	40.987/40.974 mm (1.6136/1.6131 in.)			
Crankshaft Bore (in closure plate)-to-Crankshaft Running Clearance-New	0.039/0.074 mm (0.0015/0.0029 in.)			
Flywheel End Main Bearing Journal O.D. - New O.D. - Max. Wear Limit Max. Taper Max. Out-of-Round	40.913/40.935 mm (1.6107/1.6116 in.) 40.84 mm (1.608 in.) 0.022 mm (0.0009 in.) 0.025 mm (0.0010 in.)			
Closure Plate End Main Bearing Journal O.D. - New O.D. - Max. Wear Limit Max. Taper Max. Out-of-Round	40.913/40.935 mm (1.6107/1.6116 in.) 40.84 mm (1.608 in.) 0.022 mm (0.0009 in.) 0.025 mm (0.0010 in.)			
Crankshaft (continued)				
Connecting Rod Journal O.D. - New O.D. - Max. Wear Limit Max. Taper Max. Out-of-Round	35.955/35.973 mm (1.4156/1.4163 in.) 35.94 mm (1.415 in.) 0.018 mm (0.0007 in.) 0.025 mm (0.0010 in.)			
T.I.R. PTO End, Crank in Engine Entire Crank, in V-Blocks	0.279 mm (0.0110 in.) 0.10 mm (0.0039 in.)			
Cylinder Bore				
Bore I.D. New	80.000/ 80.025 mm (3.1496/ 3.1506 in.)	82.988/83.013 mm (3.2672/3.2682 in.)		
Max. Wear Limit	80.065 mm (3.1522 in.)	83.051 mm (3.2697 in.)		
Max. Out-of-Round	0.12 mm (0.0047 in.)			
Max. Taper	0.05 mm (0.0020 in.)			
Cylinder Head				
Max. Out-of-Flatness	0.076 mm (0.003 in.)	0.1 mm (0.004 in.)		

⁴ Values are in Metric units. Values in parentheses are English equivalents.

Specifications

CLEARANCE SPECIFICATIONS⁴

CH682

CH732

CH742

CH752

Governor

Governor Cross Shaft-to-Crankcase Running Clearance	0.025/0.126 mm (0.0009/0.0049 in.)
Cross Shaft O.D. New Max. Wear Limit	7.949/8.000 mm (0.3129/0.3149 in.) 7.936 mm (0.3124 in.)
Governor Gear Shaft-to-Governor Gear Running Clearance	0.015/0.140 mm (0.0006/0.0055 in.)
Gear Shaft O.D. New Max. Wear Limit	5.990/6.000 mm (0.2358/0.2362 in.) 5.977 mm (0.2353 in.)

Ignition

Spark Plug Gap	0.76 mm (0.030 in.)
Module Air Gap	0.203/0.305 mm (0.008/0.012 in.)

Piston, Piston Rings, and Piston Pin

Piston-to-Piston Pin Running Clearance	0.006/0.017 mm (0.0002/0.0007 in.)	
Pin Bore I.D. New Max. Wear Limit	17.006/17.012 mm (0.6695/0.6698 in.) 17.025 mm (0.6703 in.)	
Pin O.D. New Max. Wear Limit	16.995/17.000 mm (0.6691/0.6693 in.) 16.994 mm (0.6691 in.)	
Top Compression Ring-to-Groove Side Clearance	0.030/0.070 mm (0.001/0.0026 in.)	
Middle Compression Ring-to-Groove Side Clearance	00.030/0.070 mm (0.001/0.0026 in.)	
Oil Control Ring-to-Groove Side Clearance	0.060/0.190 mm (0.0022/0.0073 in.)	
Top Compression Ring End Gap New Bore	0.100/ 0.279 mm (0.0039/ 0.0110 in.)	0.189/0.277 mm (0.0074/0.0109 in.)
Used Bore (Max)	0.490 mm (0.0192 in.)	0.531 mm (0.0209 in.)
Middle Compression Ring End Gap New Bore	1.400/ 1.679 mm (0.0551/ 0.0661 in.)	1.519/1.797 mm (0.0598/0.0708 in.)
Used Bore (Max)	1.941 mm (0.0764 in.)	2.051 mm (0.0808 in.)
Thrust Face O.D. New	79.966 mm (3.1483 in.) ⁹	82.978 mm (3.2668 in.) ⁸
Max. Wear Limit	79.821 mm (3.1426 in.) ⁹	82.833 mm (3.2611 in.) ⁸
Piston Thrust Face-to-Cylinder Bore Running Clearance New	0.025/ 0.068 mm (0.0010/ 0.0027 in.) ⁹	0.019/0.062 mm (0.0007/0.0024 in.) ⁸

⁴ Values are in Metric units. Values in parentheses are English equivalents.

⁸ Measure 6 mm (0.2362 in.) above bottom of piston skirt at right angles to piston pin.



⁹ Measure 13 mm (0.5118 in.) above bottom of piston skirt at right angles to piston pin.

CLEARANCE SPECIFICATIONS ⁴	CH682	CH732	CH742	CH752
Valves and Valve Lifters				
Hydraulic Valve Lifter to Crankcase Running Clearance	0.0241/0.0501 mm (0.0009/0.0020 in.)			
Intake Valve Stem-to-Valve Guide Running Clearance	0.038/0.076 mm (0.0015/0.0030 in.)			
Exhaust Valve Stem-to-Valve Guide Running Clearance	0.050/0.088 mm (0.0020/0.0035 in.)			
Intake Valve Guide I.D. New Max. Wear Limit	7.038/7.058 mm (0.2771/0.2779 in.) 7.134 mm (0.2809 in.)			
Exhaust Valve Guide I.D. New Max. Wear Limit	7.038/7.058 mm (0.2771/0.2779 in.) 7.159 mm (0.2819 in.)			
Valve Guide Reamer Size Standard 0.25 mm O.S	7.048 mm (0.2775 in.) 7.298 mm (0.2873 in.)			
Intake Valve Minimum Lift	8.07 mm (0.3177 in.)			
Exhaust Valve Minimum Lift	8.07 mm (0.3177 in.)			
Nominal Valve Seat Angle	45°			





⁴ Values are in Metric units. Values in parentheses are English equivalents.

Specifications

GENERAL TORQUE VALUES

English Fastener Torque Recommendations for Standard Applications				
Bolts, Screws, Nuts and Fasteners Assembled Into Cast Iron or Steel				Grade 2 or 5 Fasteners Into Aluminum
Size	 Grade 2	 Grade 5	 Grade 8	
Tightening Torque: N·m (in. lb.) ± 20%				
8-32	2.3 (20)	2.8 (25)	—	2.3 (20)
10-24	3.6 (32)	4.5 (40)	—	3.6 (32)
10-32	3.6 (32)	4.5 (40)	—	—
1/4-20	7.9 (70)	13.0 (115)	18.7 (165)	7.9 (70)
1/4-28	9.6 (85)	15.8 (140)	22.6 (200)	—
5/16-18	17.0 (150)	28.3 (250)	39.6 (350)	17.0 (150)
5/16-24	18.7 (165)	30.5 (270)	—	—
3/8-16	29.4 (260)	—	—	—
3/8-24	33.9 (300)	—	—	—

Tightening Torque: N·m (ft. lb.) ± 20%				
5/16-24	—	—	40.7 (30)	—
3/8-16	—	47.5 (35)	67.8 (50)	—
3/8-24	—	54.2 (40)	81.4 (60)	—
7/16-14	47.5 (35)	74.6 (55)	108.5 (80)	—
7/16-20	61.0 (45)	101.7 (75)	142.5 (105)	—
1/2-13	67.8 (50)	108.5 (80)	155.9 (115)	—
1/2-20	94.9 (70)	142.4 (105)	223.7 (165)	—
9/16-12	101.7 (75)	169.5 (125)	237.3 (175)	—
9/16-18	135.6 (100)	223.7 (165)	311.9 (230)	—
5/8-11	149.5 (110)	244.1 (180)	352.6 (260)	—
5/8-18	189.8 (140)	311.9 (230)	447.5 (330)	—
3/4-10	199.3 (147)	332.2 (245)	474.6 (350)	—
3/4-16	271.2 (200)	440.7 (325)	637.3 (470)	—

Metric Fastener Torque Recommendations for Standard Applications						
Size	Property Class					Noncritical Fasteners Into Aluminum
	 4.8	 5.8	 8.8	 10.9	 12.9	
Tightening Torque: N·m (in. lb.) ± 10%						
M4	1.2 (11)	1.7 (15)	2.9 (26)	4.1 (36)	5.0 (44)	2.0 (18)
M5	2.5 (22)	3.2 (28)	5.8 (51)	8.1 (72)	9.7 (86)	4.0 (35)
M6	4.3 (38)	5.7 (50)	9.9 (88)	14.0 (124)	16.5 (146)	6.8 (60)
M8	10.5 (93)	13.6 (120)	24.4 (216)	33.9 (300)	40.7 (360)	17.0 (150)
Tightening Torque: N·m (ft. lb.) ± 10%						
M10	21.7 (16)	27.1 (20)	47.5 (35)	66.4 (49)	81.4 (60)	33.9 (25)
M12	36.6 (27)	47.5 (35)	82.7 (61)	116.6 (86)	139.7 (103)	61.0 (45)
M14	58.3 (43)	76.4 (56)	131.5 (97)	184.4 (136)	219.7 (162)	94.9 (70)

Torque Conversions	
N·m = in. lb. x 0.113	in. lb. = N·m x 8.85
N·m = ft. lb. x 1.356	ft. lb. = N·m x 0.737

Certain quality tools are designed to help you perform specific disassembly, repair, and reassembly procedures. By using these tools, you can properly service engines easier, faster, and safer! In addition, you'll increase your service capabilities and customer satisfaction by decreasing engine downtime.

Here is a list of tools and their source.

SEPARATE TOOL SUPPLIERS

Rehiko Tools
Contact your local Rehiko source of supply.

SE Tools
415 Howard St.
Lapeer, MI 48446
Phone 810-664-2981
Toll Free 800-664-2981
Fax 810-664-8181

Design Technology Inc.
768 Burr Oak Drive
Westmont, IL 60559
Phone 630-920-1300
Fax 630-920-0011

TOOLS

Description	Source/Part No.
Alcohol Content Tester For testing alcohol content (%) in reformulated/oxygenated fuels.	Rehiko 25 455 11-S
Camshaft Endplay Plate For checking camshaft endplay.	SE Tools KLR-82405
Camshaft Seal Protector (Aegis) For protecting seal during camshaft installation.	SE Tools KLR-82417
Cylinder Leakdown Tester For checking combustion retention and if cylinder, piston, rings, or valves are worn. Individual component available: Adapter 12 mm x 14 mm (Required for leakdown test on XT-6 engines)	Rehiko 25 761 05-S Design Technology Inc. DTI-731-03
Dealer Tool Kit (Domestic) Complete kit of Rehiko required tools. Components of 25 761 39-S Ignition System Tester Cylinder Leakdown Tester Oil Pressure Test Kit Rectifier-Regulator Tester (120 V AC/60Hz)	Rehiko 25 761 39-S Rehiko 25 455 01-S Rehiko 25 761 05-S Rehiko 25 761 06-S Rehiko 25 761 20-S
Dealer Tool Kit (International) Complete kit of Rehiko required tools. Components of 25 761 42-S Ignition System Tester Cylinder Leakdown Tester Oil Pressure Test Kit Rectifier-Regulator Tester (240 V AC/50Hz)	Rehiko 25 761 42-S Rehiko 25 455 01-S Rehiko 25 761 05-S Rehiko 25 761 06-S Rehiko 25 761 41-S
Digital Vacuum/Pressure Tester For checking crankcase vacuum. Individual component available: Rubber Adapter Plug	Design Technology Inc. DTI-721-01 Design Technology Inc. DTI-721-10
Electronic Fuel Injection (EFI) Diagnostic Software For Laptop or Desktop PC.	Rehiko 25 761 23-S
EFI Service Kit For troubleshooting and setting up an EFI engine. Components of 24 761 01-S Fuel Pressure Tester Noid Light 90° Adapter Code Plug, Red Wire Code Plug, Blue Wire Shrader Valve Adapter Hose Wire Probe Set (2 pieces regular wire with clip; 1 piece fused wire) Hose Removal Tool, Dual Size/End (also sold as individual Rehiko tool) K-Line Adapter Jumper Lead Wiring Harness	Rehiko 24 761 01-S Design Technology Inc. DTI-019 DTI-021 DTI-023 DTI-027 DTI-029 DTI-037 DTI-031 DTI-033 Rehiko 25 176 23-S
Rehiko Wireless Diagnostic System Module (Bluetooth®) For wireless Android EFI diagnostics. Individual component available: Wireless Diagnostic System Interface Cable	Rehiko 25 761 45-S Rehiko 25 761 44-S

Tools and Aids

TOOLS

Description	Source/Part No.
Flywheel Puller For properly removing flywheel from engine.	SE Tools KLR-82408
Hose Removal Tool, Dual Size/End (also available in EFI Service Kit) Used to properly remove fuel hose from engine components.	Rehiko 25 455 20-S
Hydraulic Valve Lifter Tool For removing and installing hydraulic lifters.	Rehiko 25 761 38-S
Ignition System Tester For testing output on all systems, including CD.	Rehiko 25 455 01-S
Inductive Tachometer (Digital) For checking operating speed (RPM) of an engine.	Design Technology Inc. DTI-110
Offset Wrench (K and M Series) For removing and reinstalling cylinder barrel retaining nuts.	Rehiko 52 455 04-S
Oil Pressure Test Kit For testing/verifying oil pressure on pressure lubricated engines.	Rehiko 25 761 06-S
Rectifier-Regulator Tester (120 volt current) Rectifier-Regulator Tester (240 volt current) For testing rectifier-regulators. Components of 25 761 20-S and 25 761 41-S CS-PRO Regulator Test Harness Special Regulator Test Harness with Diode	Rehiko 25 761 20-S Rehiko 25 761 41-S Design Technology Inc. DTI-031R DTI-033R
Spark Advance Module (SAM) Tester For testing SAM (ASAM and DSAM) on engines with SMART-SPARK _™ .	Rehiko 25 761 40-S
Starter Servicing Kit (All Starters) For removing and reinstalling drive retaining rings and brushes. Individual component available: Starter Brush Holding Tool (Solenoid Shift)	SE Tools KLR-82411 SE Tools KLR-82416
Stepper Motor Controller Tool For testing operation of stepper motor/Digital Linear Actuator (DLA).	Rehiko 25 455 21-S
Jumper Lead Tool For use with Stepper Motor Controller Tool to test rotary stepper motor.	Rehiko 25 518 43-S
Triad/OHC Timing Tool Set For holding cam gears and crankshaft in timed position while installing timing belt.	Rehiko 28 761 01-S
Valve Guide Reamer (K and M Series) For properly sizing valve guides after installation.	Design Technology Inc. DTI-K828
Valve Guide Reamer O.S. (Command Series) For reaming worn valve guides to accept replacement oversize valves. Can be used in low-speed drill press or with handle below for hand reaming.	Rehiko 25 455 12-S
Reamer Handle For hand reaming using Rehiko 25 455 12-S reamer.	Design Technology Inc. DTI-K830

AIDS

Description	Source/Part No.
Camshaft Lubricant (Valspar ZZ613)	Rehiko 25 357 14-S
Dielectric Grease (GE/Novaguard G661)	Rehiko 25 357 11-S
Dielectric Grease	Loctite [®] 51360
Rehiko Electric Starter Drive Lubricant (Inertia Drive)	Rehiko 52 357 01-S
Rehiko Electric Starter Drive Lubricant (Solenoid Shift)	Rehiko 52 357 02-S
RTV Silicone Sealant Loctite [®] 5900 [®] Heavy Body in 4 oz. aerosol dispenser. Only oxime-based, oil resistant RTV sealants, such as those listed, are approved for use. Permatex [®] the Right Stuff [®] 1 Minute Gasket [™] or Loctite [®] Nos. 5900 [®] or 5910 [®] are recommended for best sealing characteristics.	Rehiko 25 597 07-S Loctite [®] 5910 [®] Loctite [®] Ultra Black 598 [™] Loctite [®] Ultra Blue 587 [™] Loctite [®] Ultra Copper 5920 [™] Permatex [®] the Right Stuff [®] 1 Minute Gasket [™]
Spline Drive Lubricant	Rehiko 25 357 12-S

FLYWHEEL HOLDING TOOL

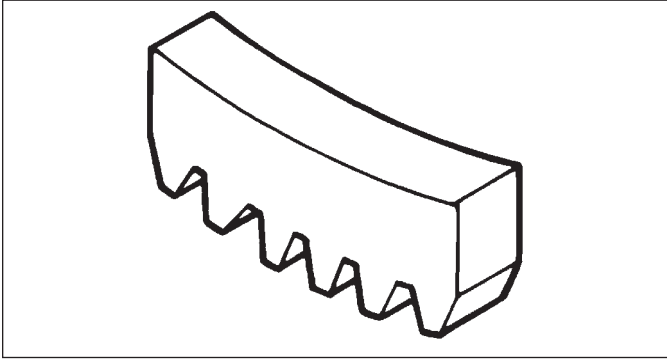

A flywheel holding tool can be made out of an old junk flywheel ring gear and used in place of a strap wrench.

1. Using an abrasive cut-off wheel, cut out a six tooth segment of ring gear as shown.
2. Grind off any burrs or sharp edges.
3. Invert segment and place it between ignition bosses on crankcase so tool teeth engage flywheel ring gear teeth. Bosses will lock tool and flywheel in position for loosening, tightening, or removing with a puller.

ROCKER ARM/CRANKSHAFT TOOL

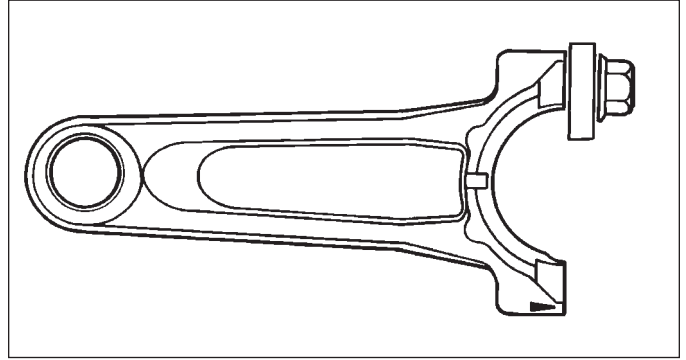

A spanner wrench to lift rocker arms or turn crankshaft may be made out of an old junk connecting rod.

1. Find a used connecting rod from a 10 HP or larger engine. Remove and discard rod cap.
2. Remove studs of a Posi-Lock rod or grind off aligning steps of a Command rod, so joint surface is flat.
3. Find a 1 in. long capscrew with correct thread size to match threads in connecting rod.
4. Use a flat washer with correct I.D. to slip on capscrew and approximately 1 in. O.D. Assemble capscrew and washer to joint surface of rod.

Troubleshooting

TROUBLESHOOTING GUIDE

When troubles occur, be sure to check simple causes which, at first, may seem too obvious to be considered. For example, a starting problem could be caused by an empty fuel tank.

Some general common causes of engine troubles are listed below and vary by engine specification. Use these to locate causing factors.

Engine Cranks But Will Not Start

- Battery connected backwards.
- Blown fuse.
- Carburetor solenoid malfunction.
- Choke not closing.
- Clogged fuel line or fuel filter.
- Diode in wiring harness failed in open circuit mode.
- DSAI or DSAM malfunction.
- Empty fuel tank.
- Faulty electronic control unit.
- Faulty ignition coil(s).
- Faulty spark plug(s).
- Fuel pump malfunction-vacuum hose clogged or leaking.
- Fuel shut-off valve closed.
- Ignition module(s) faulty or improperly gapped.
- Insufficient voltage to electronic control unit.
- Interlock switch is engaged or faulty.
- Key switch or kill switch in OFF position.
- Low oil level.
- Quality of fuel (dirt, water, stale, mixture).
- SMART-SPARK™ malfunction.
- Spark plug lead(s) disconnected.

Engine Starts But Does Not Keep Running

- Faulty carburetor.
- Faulty cylinder head gasket.
- Faulty or misadjusted choke or throttle controls.
- Fuel pump malfunction-vacuum hose clogged or leaking.
- Intake system leak.
- Loose wires or connections that intermittently ground ignition kill circuit.
- Quality of fuel (dirt, water, stale, mixture).
- Restricted fuel tank cap vent.

Engine Starts Hard

- Clogged fuel line or fuel filter.
- Engine overheated.
- Faulty ACR mechanism.
- Faulty or misadjusted choke or throttle controls.
- Faulty spark plug(s).
- Flywheel key sheared.
- Fuel pump malfunction-vacuum hose clogged or leaking.
- Interlock switch is engaged or faulty.
- Loose wires or connections that intermittently ground ignition kill circuit.
- Low compression.
- Quality of fuel (dirt, water, stale, mixture).
- Weak spark.

Engine Will Not Crank

- Battery is discharged.
- Faulty electric starter or solenoid.
- Faulty key switch or ignition switch.
- Interlock switch is engaged or faulty.
- Loose wires or connections that intermittently ground ignition kill circuit.
- Pawls not engaging in drive cup.
- Seized internal engine components.

Engine Runs But Misses

- Carburetor adjusted incorrectly.
- Engine overheated.
- Faulty spark plug(s).
- Ignition module(s) faulty or improperly gapped.
- Incorrect crankshaft position sensor air gap.
- Interlock switch is engaged or faulty.
- Loose wires or connections that intermittently ground ignition kill circuit.
- Quality of fuel (dirt, water, stale, mixture).
- Spark plug lead(s) disconnected.
- Spark plug lead boot loose on plug.
- Spark plug lead loose.

Engine Will Not Idle

- Engine overheated.
- Faulty spark plug(s).
- Idle fuel adjusting needle(s) improperly set.
- Idle speed adjusting screw improperly set.
- Inadequate fuel supply.
- Low compression.
- Quality of fuel (dirt, water, stale, mixture).
- Restricted fuel tank cap vent.

Engine Overheats

- Cooling fan broken.
- Excessive engine load.
- Fan belt failed/off.
- Faulty carburetor.
- High crankcase oil level.
- Lean fuel mixture.
- Low cooling system fluid level.
- Low crankcase oil level.
- Radiator, and/or cooling system components clogged, restricted, or leaking.
- Water pump belt failed/broken.
- Water pump malfunction.

Engine Knocks

- Excessive engine load.
- Hydraulic lifter malfunction.
- Incorrect oil viscosity/type.
- Internal wear or damage.
- Low crankcase oil level.
- Quality of fuel (dirt, water, stale, mixture).

Engine Loses Power

- Dirty air cleaner element.
- Engine overheated.
- Excessive engine load.
- Restricted exhaust.
- Faulty spark plug(s).
- High crankcase oil level.
- Incorrect governor setting.
- Low battery.
- Low compression.
- Low crankcase oil level.
- Quality of fuel (dirt, water, stale, mixture).

Engine Uses Excessive Amount of Oil

- Loose or improperly torqued fasteners.
- Blown head gasket/overheated.
- Breather reed broken.
- Clogged, broken, or inoperative crankcase breather.
- Crankcase overfilled.
- Incorrect oil viscosity/type.
- Worn cylinder bore.
- Worn or broken piston rings.
- Worn valve stems/valve guides.

Oil Leaks from Oil Seals, Gaskets

- Breather reed broken.
- Clogged, broken, or inoperative crankcase breather.
- Loose or improperly torqued fasteners.
- Piston blow by, or leaky valves.
- Restricted exhaust.

EXTERNAL ENGINE INSPECTION

NOTE: It is good practice to drain oil at a location away from workbench. Be sure to allow ample time for complete drainage.

Before cleaning or disassembling engine, make a thorough inspection of its external appearance and condition. This inspection can give clues to what might be found inside engines (and cause) when it is disassembled.

- Check for buildup of dirt and debris on crankcase, cooling fins, grass screen, and other external surfaces. Dirt or debris on these areas can cause overheating.
- Check for obvious fuel and oil leaks, and damaged components. Excessive oil leakage can indicate a clogged or inoperative breather, worn or damaged seals or gaskets, or loose fasteners.
- Check air cleaner cover and base for damage or indications of improper fit and seal.
- Check air cleaner element. Look for holes, tears, cracked or damaged sealing surfaces, or other damage that could allow unfiltered air into engine. A dirty or clogged element could indicate insufficient or improper maintenance.
- Check carburetor throat for dirt. Dirt in throat is further indication that air cleaner was not functioning properly.
- Check if oil level is within operating range on dipstick. If it is above, sniff for gasoline odor.
- Check condition of oil. Drain oil into a container; it should flow freely. Check for metal chips and other foreign particles.

Sludge is a natural by-product of combustion; a small accumulation is normal. Excessive sludge formation could indicate over rich fuel settings, weak ignition, overextended oil change interval or wrong weight or type of oil was used.

CLEANING ENGINE

	⚠ WARNING
	<p>Cleaning Solvents can cause severe injury or death.</p> <p>Use only in well ventilated areas away from ignition sources.</p>
<p>Carburetor cleaners and solvents are extremely flammable. Follow cleaner manufacturer's warnings and instructions on its proper and safe use. Never use gasoline as a cleaning agent.</p>	

After inspecting external condition of engine, clean engine thoroughly before disassembly. Clean individual components as engine is disassembled. Only clean parts can be accurately inspected and gauged for wear or damage. There are many commercially available cleaners that will quickly remove grease, oil, and grime from engine parts. When such a cleaner is used, follow manufacturer's instructions and safety precautions carefully.

Make sure all traces of cleaner are removed before engine is reassembled and placed into operation. Even small amounts of these cleaners can quickly break down lubricating properties of engine oil.

Troubleshooting

CRANKCASE VACUUM TEST

	⚠ WARNING
	Carbon Monoxide can cause severe nausea, fainting or death. Avoid inhaling exhaust fumes. Never run engine indoors or in enclosed spaces.
Engine exhaust gases contain poisonous carbon monoxide. Carbon monoxide is odorless, colorless, and can cause death if inhaled.	

	⚠ WARNING
	Rotating Parts can cause severe injury. Stay away while engine is in operation.
Keep hands, feet, hair, and clothing away from all moving parts to prevent injury. Never operate engine with covers, shrouds, or guards removed.	

A partial vacuum should be present in crankcase when engine is operating. Pressure in crankcase (normally caused by a clogged or improperly assembled breather) can cause oil to be forced out at oil seals, gaskets, or other available spots.

Crankcase vacuum is best measured with either a water manometer or a vacuum gauge. Complete instructions are provided in kits.

To test crankcase vacuum with manometer:

1. Insert rubber stopper into oil fill hole. Be sure pinch clamp is installed on hose and use tapered adapters to connect hose between stopper and one manometer tube. Leave other tube open to atmosphere. Check that water level in manometer is at 0 line. Make sure pinch clamp is closed.
2. Start engine and run no-load high speed.
3. Open clamp and note water level in tube.
Level in engine side should be a minimum of 10.2 cm (4 in.) above level in open side.
If level in engine side is less than specified (low/no vacuum), or level in engine side is lower than level in open side (pressure), check for conditions in table below.
4. Close pinch clamp before stopping engine.

To test crankcase vacuum with vacuum/pressure gauge:

1. Remove dipstick or oil fill plug/cap.
2. Install adapter into oil fill//dipstick tube opening, upside down over end of a small diameter dipstick tube, or directly into engine if a tube is not used. Insert barbed gauge fitting into hole in stopper.
3. Run engine and observe gauge reading.
Analog tester—needle movement to left of 0 is a vacuum, and movement to right indicates a pressure.
Digital tester—depress test button on top of tester.
Crankcase vacuum should be a minimum of 10.2 cm (4 in.) of water. If reading is below specification, or if pressure is present, check table below for possible causes and conclusions.

Condition	Conclusion
Crankcase breather clogged or inoperative.	NOTE: If breather is integral part of valve cover and cannot be serviced separately, replace valve cover and recheck pressure. Disassemble breather, clean parts thoroughly, check sealing surfaces for flatness, reassemble, and recheck pressure.
Seals and/or gaskets leaking. Loose or improperly torque fasteners.	Replace all worn or damaged seals and gaskets. Make sure all fasteners are tightened securely. Use appropriate torque valves and sequences when necessary.
Piston blow by or leaky valves (confirm by inspecting components).	Recondition piston, rings, cylinder bore, valves and valves guides.
Restricted exhaust.	Check exhaust screen/spark arrestor (if equipped). Clean or replace as needed. Repair or replace any other damaged/restricted muffler or exhaust system parts.

COMPRESSION TEST

For Command Twins:

A compression test is best performed on a warm engine. Clean any dirt or debris away from base of spark plug(s) before removing them. Be sure choke is off, and throttle is wide open during test. Compression should be at least 160 psi and should not vary more than 15% between cylinders.

All other models:

These engines are equipped with an automatic compression release (ACR) mechanism. It is difficult to obtain an accurate compression reading because of ACR mechanism. As an alternative, use cylinder leakdown test described below.

CYLINDER LEAKDOWN TEST

A cylinder leakdown test can be a valuable alternative to a compression test. By pressurizing combustion chamber from an external air source you can determine if valves or rings are leaking, and how badly.

Cylinder leakdown tester is a relatively simple, inexpensive leakdown tester for small engines. This tester includes a quick-connect for attaching adapter hose and a holding tool.

1. Run engine for 3-5 minutes to warm it up.
2. Remove spark plug(s) and air filter from engine.
3. Rotate crankshaft until piston (of cylinder being tested) is at top dead center (TDC) of compression stroke. Hold engine in this position while testing. Holding tool supplied with tester can be used if PTO end of crankshaft is accessible. Lock holding tool onto crankshaft. Install a 3/8 in. breaker bar into hole/slot of holding tool, so it is perpendicular to both holding tool and crankshaft PTO.
If flywheel end is more accessible, use a breaker bar and socket on flywheel nut/screw to hold it in position. An assistant may be needed to hold breaker bar during testing. If engine is mounted in a piece of equipment, it may be possible to hold it by clamping or wedging a driven component. Just be certain that engine cannot rotate off of TDC in either direction.
4. Install adapter into spark plug hole, but do not attach it to tester at this time.
5. Turn regulator knob completely counterclockwise.
6. Connect an air source of at least 50 psi to tester.
7. Turn regulator knob clockwise (increase direction) until gauge needle is in yellow set area at low end of scale.
8. Connect tester quick-connect to adapter hose. While firmly holding engine at TDC, gradually open tester valve. Note gauge reading and listen for escaping air at combustion air intake, exhaust outlet, and crankcase breather.

Condition	Conclusion
Air escaping from crankcase breather.	Ring or cylinder worn.
Air escaping from exhaust system.	Defective exhaust valve/improper seating.
Air escaping from intake.	Defective intake valve/improper seating.
Gauge reading in low (green) zone.	Piston rings and cylinder in good condition.
Gauge reading in moderate (yellow) zone.	Engine is still usable, but there is some wear present. Customer should start planning for overhaul or replacement.
Gauge reading in high (red) zone.	Rings and/or cylinder have considerable wear. Engine should be reconditioned or replaced.

Air Cleaner/Intake

AIR CLEANER

These systems are CARB/EPA certified and components should not be altered or modified in any way.

Air Cleaner Components

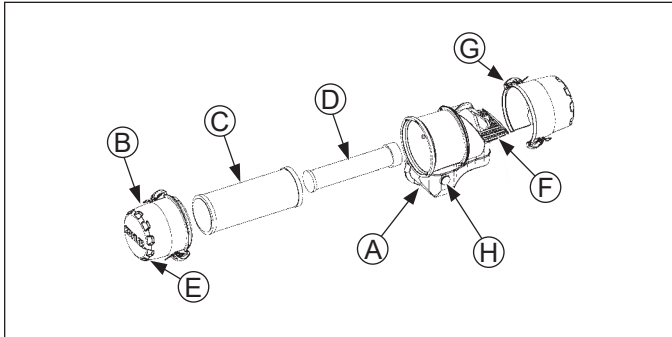

A	Air Cleaner Housing	B	End Cap
C	Element	D	Inner Element
E	Ejector Area	F	Inlet Screen
G	Retaining Clip	H	Filter Minder

NOTE: Operating engine with loose or damaged air cleaner components could cause premature wear and failure. Replace all bent or damaged components.

NOTE: Paper element cannot be blown out with compressed air.

1. Unhook retaining clips and remove end cap(s).
2. Check and clean inlet screen (if equipped).
3. Pull air cleaner element out of housing and replace. Check condition of inner element; replace when dirty.
4. Check all parts for wear, cracks, or damage, and that ejector area is clean.
5. Install new element(s).
6. Reinstall end cap(s) with dust ejector valve/screen down; secure with retaining clips.

BREATHER TUBE

Ensure both ends of breather tube are properly connected.

AIR COOLING

	⚠ WARNING
	<p>Hot Parts can cause severe burns. Do not touch engine while operating or just after stopping.</p>
<p>Never operate engine with heat shields or guards removed.</p>	

Proper cooling is essential. To prevent over heating, clean screens, cooling fins, and other external surfaces of engine. Avoid spraying water at wiring harness or any electrical components. Refer to Maintenance Schedule.

Typical carbureted fuel system and related components include:

- Fuel tank and valve.
- Fuel lines.
- In-line fuel filter.
- Fuel pump.
- Carburetor.

Fuel from tank is moved through in-line filter and fuel lines by fuel pump. Fuel then enters carburetor float bowl and is drawn into carburetor body and mixed with air. This fuel-air mixture is then burned in engine combustion chamber.

FUEL RECOMMENDATIONS

Refer to Maintenance.

FUEL LINE

Low permeation fuel line must be installed on carbureted Rehlko Co. engines to maintain EPA and CARB regulatory compliance.

FUEL PUMP

These engines use either a mechanical pump or a pulse style fuel pump. Pumping action of pulse style pumps is created by oscillation of positive and negative pressures within crankcase. This pressure is transmitted to pulse pump through rubber hose connected between pump and crankcase. Pumping action causes diaphragm on inside of pump to pull fuel in on its downward stroke and to push it into carburetor on its upward stroke. Two check valves prevent fuel from going backward through pump.

FUEL SYSTEM TESTS

When engine starts hard or turns over but will not start, fuel system might be causing problems. Test fuel system by performing following test.

1. Check for fuel in combustion chamber.
 - a. Disconnect and ground spark plug leads.
 - b. Close choke on carburetor.
 - c. Crank engine several times.
 - d. Remove spark plug and check for fuel at tip.
2. Check for fuel flow from tank to fuel pump.
 - a. Remove fuel line from inlet fitting of fuel pump.
 - b. Hold line below bottom of tank. Open shut-off valve (if equipped) and observe flow.
3. Check operation of fuel pump.
 - a. Remove fuel line from inlet fitting of carburetor.
 - b. Crank engine several times and observe flow.

Performance

Minimum fuel delivery rate must be 7.5 L/hr. (2 gal./hr.) with a pressure at 0.3 psi and a fuel lift of 24 in. A 1.3 L/hr. (0.34 gal./hr.) fuel rate must be maintained at 5 Hz.

Fuel Pump Replacement

Pulse Fuel Pump

NOTE: Make sure orientation of new pump is consistent with removed pump. Internal damage may occur if installed incorrectly.

To replace pulse pump follow these steps. Note orientation of pump before removing.

1. Disconnect fuel lines from inlet, outlet, and pulse fittings on fuel pump.
2. Remove screws and take off pump.
3. Connect pulse line to new fuel pump and make sure opposite end is properly connected to fitting on crankcase.
4. Attach new fuel pump using screws. Torque screws to 2.3 N·m (20 in. lb.).
5. Reconnect fuel lines to inlet and outlet fittings and secure with clamps.

Mechanical Pump

Mechanical fuel pump is an integral part of valve cover assembly and not serviced separately.

1. Disconnect fuel lines from inlet and outlet fittings. Note orientation.
2. Follow procedure for replacing valve cover. Refer to Disassembly and Reassembly.
3. Reconnect fuel lines to inlet and outlet fittings and secure with clamps.

Condition	Conclusion
Fuel at tip of spark plug.	Fuel is reaching combustion chamber.
No fuel at tip of spark plug.	Check fuel flow from fuel tank (step 2).
Fuel flows from fuel line.	Check for faulty fuel pump (step 3). If fuel pump is working, check for faulty carburetor. Refer to Carburetor.
No fuel flow from fuel line.	Check fuel tank cap vent, fuel pickup screen, in-line filter, shut-off valve, and fuel line. Correct any observed problem and reconnect line.
Fuel line condition.	Check for a clogged fuel line. If fuel line is unobstructed, check for overfilled crankcase and/or oil in pulse line. If checks don't reveal cause of problem, replace pump.

Fuel System

CARBURETOR



WARNING

Explosive Fuel can cause fires and severe burns.

Do not fill fuel tank while engine is hot or running.

Gasoline is extremely flammable and its vapors can explode if ignited. Store gasoline only in approved containers, in well ventilated, unoccupied buildings, away from sparks or flames. Spilled fuel could ignite if it comes in contact with hot parts or sparks from ignition. Never use gasoline as a cleaning agent.

Walbro Two-Barrel Carburetor Components

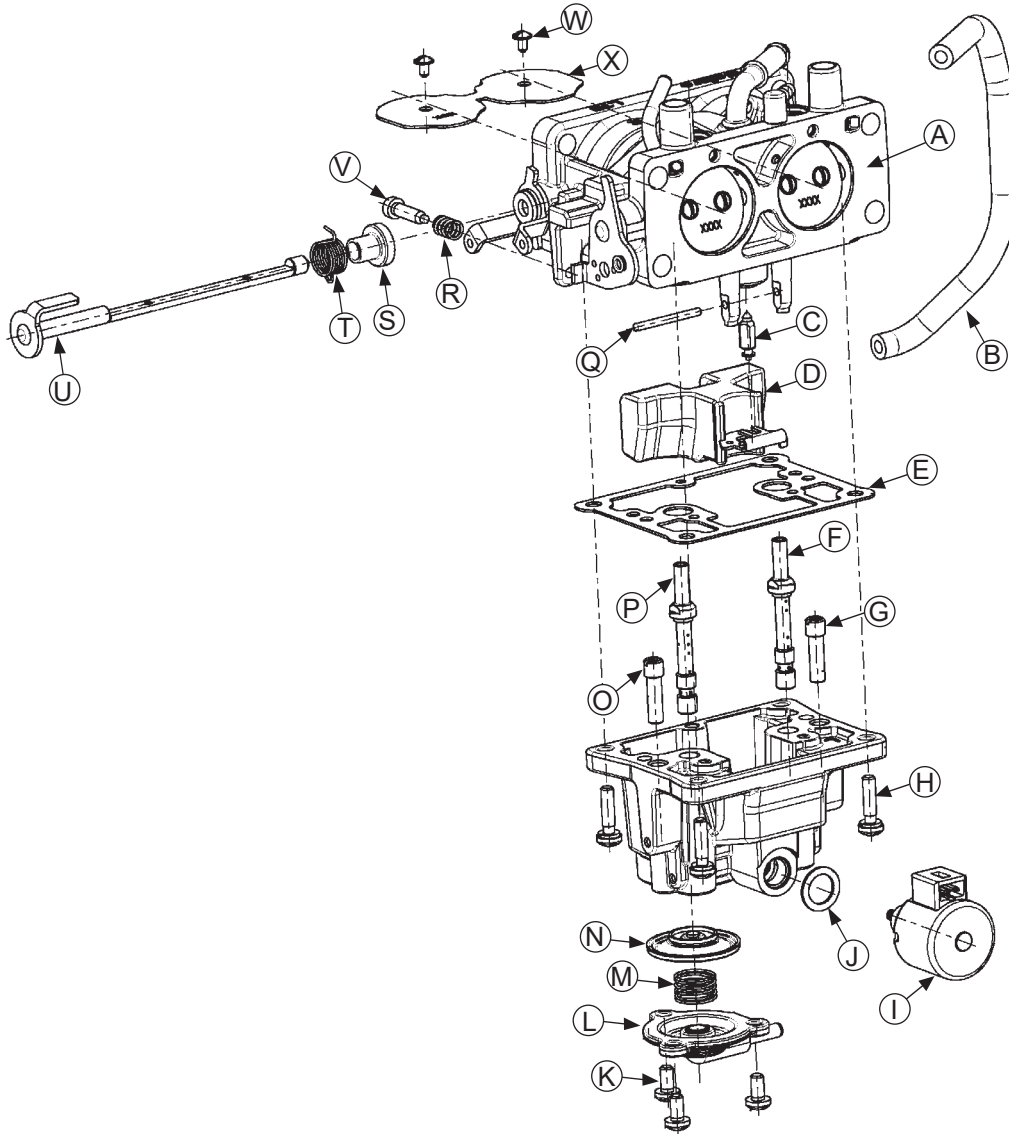

A	Carburetor Body Subassembly	B	Vacuum Hose	C	Float Valve/Inlet Needle	D	Float	E	Bowl Gasket
F	Main Nozzle-Left Side	G	Slow Jet-Left Side	H	Bowl Screw	I	Fuel Solenoid	J	Solenoid Gasket
K	Accelerator Pump Cover Screws	L	Accelerator Pump Cover	M	Spring	N	Diaphragm	O	Slow Jet-Right Side
P	Main Nozzle-Right Side	Q	Float Pin	R	Idle Spring	S	Plastic Dust Seal Cover	T	Choke Spring
U	Choke Shaft	V	Idle Speed Screw	W	Choke Plate Screw	X	Choke Plate		

Engines in this series are equipped with a two-barrel side-draft carburetor with fixed main jets on a matching intake manifold. Carburetor features a self-relieving choke, serviceable slow jets, main jets, accelerator pump, and a fuel shutdown solenoid.

Troubleshooting Checklist

When engine starts hard, runs roughly or stalls at low idle speed, check following areas before adjusting or disassembling carburetor.

1. Make sure fuel tank is filled with clean, fresh gasoline.
2. Make sure fuel tank cap vent is not blocked and that it is operating properly.
3. Make sure fuel is reaching carburetor. This includes checking fuel shut-off valve, fuel tank filter screen, in-line fuel filter, fuel lines and fuel pump for restrictions or faulty components as necessary.
4. Make sure air cleaner base and carburetor are securely fastened to engine using gaskets in good condition.
5. Make sure air cleaner element (including precleaner if equipped) is clean and all air cleaner components are fastened securely.
6. Make sure ignition system, governor system, exhaust system, and throttle and choke controls are operating properly.

Troubleshooting-Carburetor Related Causes

Condition	Possible Cause	Conclusion
Engine starts hard, runs rough, or stalls at idle speed.	Low idle speed improperly adjusted.	Adjust low idle speed tab.
Engine runs rich (indicated by black, sooty exhaust smoke, misfiring, loss of speed and power, governor hunting, or excessive throttle opening).	Clogged air cleaner.	Clean or replace air cleaner.
	Choke partially closed during operation.	Check choke lever/linkage to ensure choke is operating properly.
	Float level is set too high.	Adjust float according to Float Replacement Procedure.
	Dirt under fuel inlet needle.	Remove needle; clean needle and seat and blow with compressed air.
	Bowl vent or air bleeds plugged.	Remove low idle fuel adjusting needle. Clean vent, ports, and air bleeds. Blow out all passages with compressed air.
Engine runs lean (indicated by misfiring, loss of speed and power, governor hunting, or excessive throttle opening).	Float level is set too low.	Adjust float according to Float Replacement Procedure.
	Idle holes plugged; dirt in fuel delivery channels.	Remove low idle fuel adjusting needle. Clean main fuel jet and all passages; blow out with compressed air.
Fuel leaks from carburetor.	Float level is set too high.	Adjust float according to Float Replacement Procedure.
	Dirt under fuel inlet needle.	Remove needle; clean needle and seat and blow with compressed air.
	Bowl vents plugged.	Blow out with compressed air.
	Carburetor bowl gasket leaks.	Replace gasket.

Fuel System

Fuel Shut-Off Solenoid

Carburetors are equipped with a fuel shut-off solenoid. Solenoid is attached to fuel bowl. Solenoid has a spring-loaded pin that retracts when 12 volts is applied to lead, allowing fuel flow to main jet. When current is removed, pin extends blocking fuel flow.

Below is a simple test, performed with engine off, that can determine if solenoid is functioning properly.

1. Shut off fuel and remove solenoid from carburetor. When solenoid is loosened and removed, gas will leak out of carburetor. Have a container ready to catch fuel.
2. Wipe tip of solenoid with a shop towel or blow with compressed air to remove any remaining fuel. Take solenoid to a location with good ventilation and no fuel vapors present. You will also need a 12 volt power source that can be switched on and off.
3. Be sure power source is switched OFF. Connect positive power source lead to red lead of solenoid. Connect negative power source lead to solenoid body.
4. Turn power source ON and observe pin in center of solenoid. Pin should retract with power ON and return to its original position with power OFF. Test several times to verify operation.

Carburetor Circuits

Float

Fuel level in bowl is maintained by float and fuel inlet needle. Buoyant force of float stops fuel flow when engine is at rest. When fuel is being consumed, float will drop and fuel pressure will push inlet needle away from seat, allowing more fuel to enter bowl. When demand ceases, buoyant force of float will again overcome fuel pressure, rising to predetermined setting and stop flow.

Slow and Mid-Range

At low speeds engine operates only on slow circuit. As a metered amount of air is drawn through slow air bleed jets, fuel is drawn through 2 main jets and further metered through slow jets. Air and fuel are mixed in body of slow jet and exit to transfer port. From transfer port, air fuel mixture is delivered to idle progression chamber. From idle progression chamber, air fuel mixture is metered through idle port passages. At low idle when vacuum signal is weak, air/fuel mixture is controlled by setting of idle fuel adjusting screws. This mixture is then mixed with main body of air and delivered to engine. As throttle plate opening increases, greater amounts of air/fuel mixture are drawn in through fixed and metered idle progression holes. As throttle plate opens further, vacuum signal becomes great enough so main circuit begins to work.

Main (high-speed)

At high speeds/loads engine operates on main circuit. As a metered amount of air is drawn through 4 air jets, fuel is drawn through main jets. Air and fuel are mixed in main nozzles then enters main body of airflow where further mixing of fuel and air occurs. This mixture is then delivered to combustion chamber. Carburetor has a fixed main circuit; no adjustment is possible.

Carburetor Adjustments

NOTE: Carburetor adjustments should be made only after engine has warmed up.

Carburetor is designed to deliver correct fuel-to-air mixture to engine under all operating conditions. Main fuel jet is calibrated at factory and is not adjustable. Idle fuel adjusting needles are also set at factory and normally do not need adjustment.

Low Idle Speed (RPM) Adjustment

NOTE: Actual low idle speed depends on application. Refer to equipment manufacturer's recommendations. Low idle speed for basic engines is 1200 RPM.

Place throttle control into idle or slow position. Turn low idle speed adjusting screw in or out to obtain allow idle speed of 1200 RPM (\pm 75 RPM).



Governed Idle Speed Adjustment (If equipped)

1. Hold governor lever away from carburetor so throttle lever is against idle speed (RPM) adjustment screw of carburetor. Start engine and allow to warm up, then adjust screw to set approximately 1200 RPM. Check speed using a tachometer. Turn adjustment screw (inner) clockwise (in) to increase or counterclockwise (out) to decrease speed.
2. Release governor lever and check that throttle lever is in idle position. Turn governed idle adjustment screw to obtain equipment manufacturer's recommended idle speed (1500-1800 RPM). Some engines have a bendable tab that is used to set this speed. A pliers should be used to bend this tab to achieve recommended speed. Governed idle speed (RPM) is typically 300 RPM (approximate) higher than low idle speed.
3. Move throttle lever to wide-open/full throttle position and hold in this position. Turn high speed screw to obtain intended high speed no-load RPM. Governed idle speed must be set before making this adjustment.

High Speed (RPM) Adjustment

1. With engine running, move throttle control to fast.
2. Turn inner adjustment screw outward to decrease, or inward to increase RPM speed.
3. Stop when desired RPM speed is obtained.

Carburetor Servicing

	 WARNING
	<p>Accidental Starts can cause severe injury or death.</p> <p>Disconnect and ground spark plug lead(s) before servicing.</p>
<p>Before working on engine or equipment, disable engine as follows: 1) Disconnect spark plug lead(s). 2) Disconnect negative (-) battery cable from battery.</p>	

NOTE: Main and slow jets are fixed and size specific and can be removed if required. Fixed jets for high altitudes are available.

NOTE: Keep solvent away from plastic or rubber parts if non-compatible or damage may occur.

- Inspect carburetor body for cracks, holes, and other wear or damage.
- Inspect float for cracks, holes, and missing or damaged float tabs. Check float hinge and shaft for wear or damage.
- Inspect fuel inlet needle and seat for wear or damage.
- Inspect spring loaded choke plate to make sure it moves freely on shaft.

Float Replacement/Overhaul/Choke Repair

Float Setting

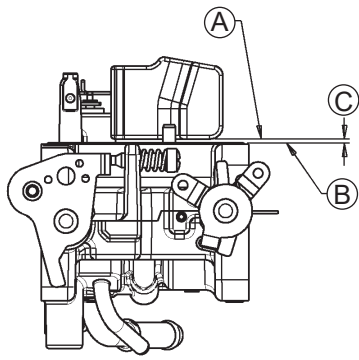

A	Top of Float Body (Carburetor Body Inverted)
B	Top of Gasket Crush Ribs
C	1.6 mm (0.063 in.) +/- 0.5 mm (0.02 in.) Float Setting

NOTE: Inlet needle center pin is spring loaded. Make sure float rests against fuel inlet needle without depressing center pin.

If symptoms described in Troubleshooting-Carburetor Related Causes indicate float level problems, remove carburetor from engine to check and/or replace float. Use a float kit to replace float, pin, float valve.

1. Perform removal procedures for appropriate air cleaner and carburetor outlined in Disassembly.
2. Clean exterior surfaces of dirt or foreign material before disassembling carburetor. Disconnect accelerator pump vacuum hose from bottom of bowl. Remove screws and carefully separate fuel bowl from carburetor. Transfer any remaining fuel into an approved container. Discard bowl screws and gasket; save other parts.
3. Remove float pin, lift out float and inlet needle; discard parts. Seat for inlet needle is not serviceable and should not be removed.
4. Use a 1/4" open end wrench and carefully remove nozzle tubes from bowl. Note and mark jets by location for proper reassembly. Main jets and main nozzles may be size/side specific. Main jets are pressed into bottom of main nozzle tubes and are not serviced separately. Slow jets are located to outside of nozzle tubes and are removed with a narrow, straight blade screwdriver. Save parts for cleaning and reuse.
5. Remove accelerator pump cover screws from bottom of bowl while holding pump cover in place. Accelerator pump spring will be pushing against cover as it is directly under it. Remove and discard spring and diaphragm. Solenoid can also be removed using a 1/2" wrench and gasket discarded.
6. Carburetor is now disassembled for appropriate cleaning and installation of parts in overhaul kit. Further disassembly is not necessary. Throttle shaft assembly, fuel inlet seat, idle fuel adjustment screws are non-serviceable items and should not be removed. Choke shaft assembly is serviceable, however it should not be removed unless a choke repair kit will be installed.

To install choke repair kit go to step 7, otherwise go to step 14.

7. Clean areas around choke lever/shaft assembly and self-relieving choke mechanism thoroughly.
8. Note position of spring hooks and choke plate for correct reassembly later. Remove screws attaching choke plate to choke shaft. Pull shaft out of carburetor body, note preload of spring and discard removed parts.
9. Clean I.D. of both choke shaft bores as required.
10. Install new spring, plastic dust seal cover, and dust seal on shaft.
11. Slide choke shaft assembly into carburetor, connecting spring hooks to levers. Before seating choke shaft completely, lever needs to be rotated clockwise slightly to get past stop. This preloads choke plate for proper starting function.
12. Position and reinstall choke plate to flat side of choke shaft. Start screws. Close choke and check plate alignment within carburetor throat, then tighten screws securely. Do not overtighten.
13. Check for proper operation and free movement of parts.

Fuel System

14. Clean carburetor body, main jets, vent ports, seats, etc., using a good commercially available carburetor solvent. Keep solvent away from plastic or rubber parts if non-compatible or damage may occur. Use clean, dry compressed air to blow out internal channels and ports. Do not use metal tools or wire to clean orifices and jets. Inspect and thoroughly check carburetor for cracks, wear, or damage. Inspect fuel inlet seat for wear or damage. Check spring loaded choke plate to make sure it moves freely on shaft.
15. Clean carburetor fuel bowl as required, including accelerator jet, feed hole, and check valve in bottom of bowl.
16. Install new diaphragm assembly with outer lip resting in groove of pump base. Install new spring on top of diaphragm center plate. Reinstall cover and secure with new screws. Torque screws to 1-1.4 N·m (8-12 in. lb.). Reinstall solenoid using new gasket and torque solenoid to 3.4-5.6 N·m (30-50 in. lb.).
17. Reinstall main nozzles assemblies and slow jets in their respective sides.
18. Attach new inlet needle into metal hinge of float. Groove near top of needle slides into formed fork.
19. Install float and inlet needle down into seat and carburetor body. With float hinge held in between body mounting legs, insert new pivot pin through float hinge and into opposite hole.
20. Invert carburetor body as shown and measure dimension between top of float and top of gasket float rib on body. Correct float setting is 1.6 mm (0.063 in.) ± 0.5 mm (0.02 in.).
21. If float height adjustment is required, a small flat blade screwdriver can be used to pry tab up from side, or pry tab down on end.
22. When proper float height is obtained, carefully reinstall fuel bowl, using new bowl gasket. Secure with new screws. Torque screws to 2.3-2.7 N·m (20-24 in. lb.).
23. Reattach accelerator pump vacuum hose.
24. Use new mounting gaskets for air cleaner and carburetor. Reinstall carburetor and disassembled components following Reassembly procedures.
25. Reconnect spark plug leads and negative battery cable. Start engine and perform Low Idle Speed Adjustment.

High Altitude Operation

If this engine is operated at an altitude of 4000 ft. (1219 meters) or above, a high altitude carburetor kit is required. To obtain high altitude carburetor kit information or to find an authorized dealer, visit engines.rehiko.com or call 1-800-544-2444 (U.S. and Canada).

This engine should be operated in its original configuration below 4000 ft. (1219 meters).

Operating this engine with the wrong engine configuration at a given altitude may increase its emissions, decrease fuel efficiency and performance, and result in damage to the engine.

GOVERNOR

Engine is equipped with a centrifugal flyweight mechanical governor. It is designed to hold engine speed constant under changing load conditions. Governor gear/flyweight mechanism is mounted inside crankcase on closure plate, and is driven off gear on camshaft.

Governor Components

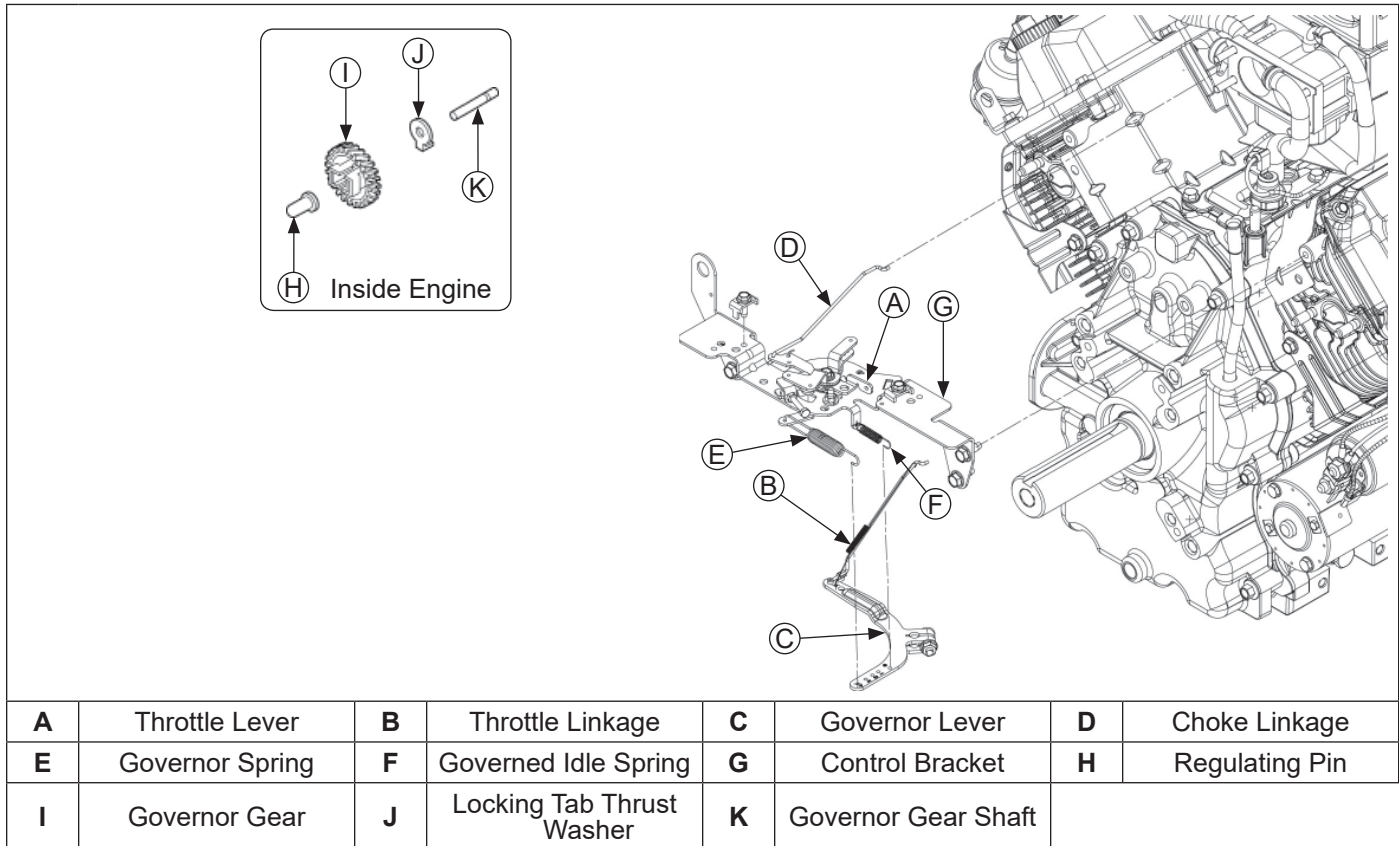

This governor design works as follows:

- Centrifugal force acting on rotating governor gear assembly causes flyweights to move outward as speed increases. Governor spring tension moves them inward as speed decreases.
- As flyweights move outward, they cause regulating pin to move outward.
- Regulating pin contacts tab on cross shaft causing shaft to rotate. One end of cross shaft protrudes through crankcase. Rotating action of cross shaft is transmitted to throttle lever of carburetor through external linkage.
- When engine is at rest, and throttle is in FAST position, tension of governor spring holds throttle plate open. When engine is operating, governor gear assembly is rotating. Force applied by regulating pin against cross shaft tends to close throttle plate. Governor spring tension and force applied by regulating pin balance each other during operation, to maintain engine speed.
- When load is applied and engine speed and governor gear speed decreases, governor spring tension moves governor lever to open throttle plate wider. This allows more fuel into engine, increasing engine speed. As speed reaches governed setting, governor spring tension and force applied by regulating pin will again offset each other to hold a steady engine speed.

Governor Adjustments

NOTE: Do not tamper with governor setting. Overspeed is hazardous and could cause personal injury.

Initial Adjustment Procedure

Make this adjustment whenever governor arm is loosened or removed from cross shaft. Adjust as follows:

1. Make sure throttle linkage is connected to governor arm and throttle lever on carburetor.
2. Loosen nut holding governor lever to cross shaft.
3. Move governor lever toward carburetor as far as it will go (wide open throttle) and hold in this position.
4. Insert a long thin rod or tool into hole on cross shaft and rotate shaft counterclockwise (viewed from end) as far as it will turn, then torque nut to 6.8 N·m (60 in. lb.).

Governor System

Sensitivity Adjustment

Governor sensitivity is adjusted by repositioning governor spring in holes of governor lever. If speed surging occurs with a change in engine load, governor is set too sensitive. If a big drop in speed occurs when normal load is applied, governor should be set for greater sensitivity and adjust as follows:

1. To increase sensitivity, move spring closer to governor cross shaft.
2. To decrease sensitivity, move spring away from governor cross shaft.

This engine uses a full pressure lubrication system which delivers oil under pressure to crankshaft, camshaft, connecting rod bearing surfaces, and hydraulic valve lifters.

A high-efficiency gerotor oil pump maintains high oil flow and oil pressure, even at low speeds and high operating temperatures. A pressure relief valve limits maximum pressure of system. Closure plate must be removed to service oil pickup, pressure relief valve, and oil pump.

Lubrication Components

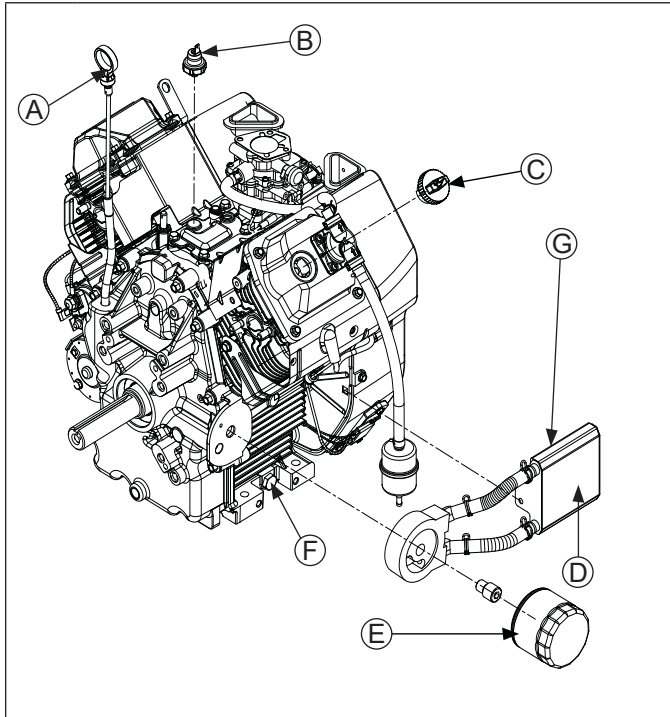

A	Dipstick	B	Oil Sentry™
C	Oil Fill Cap	D	Oil Cooler
E	Oil Filter	F	Oil Drain Plug
G	Back Side		

OIL RECOMMENDATIONS

Refer to Maintenance.

CHECK OIL LEVEL

NOTE: To prevent extensive engine wear or damage, never run engine with oil level below or above operating range indicator on dipstick.

Ensure engine is cool. Clean oil fill/dipstick areas of any debris.

1. Remove dipstick; wipe oil off.
2. Reinsert dipstick into tube; press completely down.
3. Remove dipstick; check oil level. Level should be at top of indicator on dipstick.
4. If oil is low on indicator, add oil up to top of indicator mark.
5. Reinstall dipstick and tighten securely.

CHANGE OIL AND FILTER

Change oil while engine is warm.

1. Clean area around oil fill cap/dipstick, drain plug/oil drain valve.
 - a. Remove drain plug and oil fill cap/dipstick. Allow oil to drain completely.

or
 - b. Open oil drain valve cap; if needed, attach a length of 1/2 in. I.D. hose to direct oil into appropriate container; twist valve drain body counterclockwise and pull. Remove dipstick. Allow oil to drain completely.
2. Clean area around oil filter. Place a container under filter to catch any oil and remove filter. Wipe off mounting surface.
 - a. Reinstall drain plug. Torque to 13.6 N·m (10 ft. lb.).

or
 - b. Close oil drain valve body, remove hose (if used), and replace cap.
3. Place new filter in shallow pan with open end up. Fill with new oil until oil reaches bottom of threads. Allow 2 minutes for oil to be absorbed by filter material.
4. Apply a thin film of clean oil to rubber gasket on new filter.
5. Refer to instructions on oil filter for proper installation.
6. Fill crankcase with new oil. Level should be at top of indicator on dipstick.
7. Reinstall oil fill cap/dipstick and tighten securely.
8. Start engine; check for oil leaks. Stop engine; correct leaks. Recheck oil level.
9. Dispose of used oil and filter in accordance with local ordinances.

OIL COOLER (if equipped)

1. Clean fins with a brush or compressed air.
2. Remove screws securing oil cooler and tilt to clean back side.
3. Reinstall oil cooler.

Lubrication System

OIL SENTRY™ (if equipped)

This switch is designed to prevent engine from starting in a low oil or no oil condition. Oil Sentry™ may not shut down a running engine before damage occurs. In some applications this switch may activate a warning signal. Read your equipment manuals for more information.

Oil Sentry™ pressure switch is installed in breather cover. On engines not equipped with Oil Sentry™ installation hole is sealed with a 1/8-27 N.P.T.F. pipe plug.

Installation

1. Apply pipe sealant with Teflon® (Loctite® PST® 592™ Thread Sealant or equivalent) to threads of switch.
2. Install switch into tapped hole in breather cover.
3. Torque switch to 4.5 N·m (40 in. lb.).

Testing

Compressed air, a pressure regulator, pressure gauge, and a continuity tester are required to test switch.

1. Connect continuity tester across blade terminal and metal case of switch. With 0 psi pressure applied to switch, tester should indicate continuity (switch closed).
2. Gradually increase pressure to switch. As pressure increases through range of 3-5 psi tester should indicate a change to no continuity (switch open). Switch should remain open as pressure is increased to 90 psi maximum.
3. Gradually decrease pressure through range of 3-5 psi. Tester should indicate a change to continuity (switch closed) down to 0 psi.
4. Replace switch if it does not operate as specified.

SPARK PLUGS



⚠ CAUTION

Electrical Shock can cause injury.
Do not touch wires while engine is running.

Spark Plug Component and Details

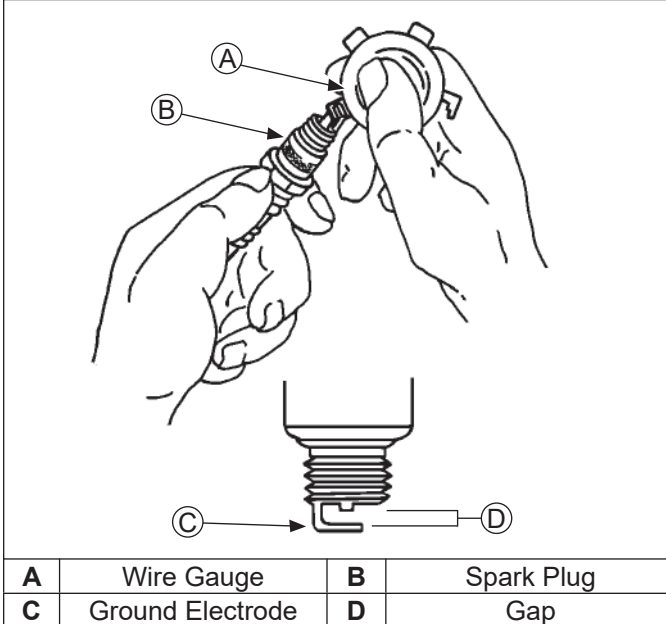

NOTE: Do not clean spark plug in a machine using abrasive grit. Some grit could remain in spark plug and enter engine causing extensive wear and damage.

Engine misfire or starting problems are often caused by a spark plug that has improper gap or is in poor condition.

Engine is equipped with following spark plugs:

Gap	0.76 mm (0.030 in.)
Thread Size	14 mm
Reach	19.1 mm (3/4 in.)
Hex Size	15.9 mm (5/8 in.)

Refer to Maintenance for Repairs/Service Parts.

Service

Clean out spark plug recess. Remove plug and replace.

1. Check gap using wire feeler gauge. Adjust gap to 0.76 mm (0.030 in.).
2. Install plug into cylinder head.
3. Torque plug to 27 N·m (20 ft. lb.).

Inspection

Inspect each spark plug as it is removed from cylinder head. Deposits on tip are an indication of general condition of piston rings, valves, and carburetor.

Normal and fouled plugs are shown in following photos:

Normal

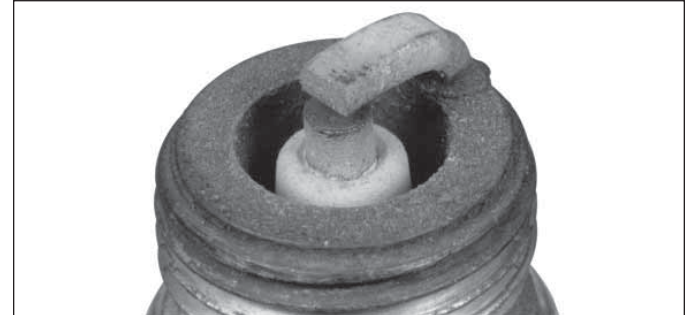

Plug taken from an engine operating under normal conditions will have light tan or gray colored deposits. If center electrode is not worn, plug can be set to proper gap and reused.

Worn



On a worn plug, center electrode will be rounded and gap will be greater than specified gap. Replace a worn spark plug immediately.

Wet Fouled



A wet plug is caused by excess fuel or oil in combustion chamber. Excess fuel could be caused by a restricted air cleaner, a carburetor problem, or operating engine with too much choke. Oil in combustion chamber is usually caused by a restricted air cleaner, a breather problem, worn piston rings, or valve guides.

Electrical System

Carbon Fouled



Soft, sooty, black deposits indicate incomplete combustion caused by a restricted air cleaner, over rich carburetion, weak ignition, or poor compression.

Overheated



Chalky, white deposits indicate very high combustion temperatures. This condition is usually accompanied by excessive gap erosion. Lean carburetor settings, an intake air leak, or incorrect spark timing are normal causes for high combustion temperatures.

BATTERY

A 12-volt battery with 400 cold cranking amps (cca) is generally recommended for starting in all conditions. A smaller capacity battery is often sufficient if an application is started only in warmer temperatures. Refer to following table for minimum capacities based on anticipated ambient temperatures. Actual cold cranking requirement depends on engine size, application, and starting temperatures. Cranking requirements increase as temperatures decrease and battery capacity shrinks. Refer to equipment's operating instructions for specific battery requirements.

Battery Size Recommendations

Temperature	Battery Required
Above 32°F (0°C)	200 cca minimum
0°F to 32°F (-18°C to 0°C)	250 cca minimum
-5°F to 0°F (-21°C to -18°C)	300 cca minimum
-10°F (-23°C) or below	400 cca minimum

If battery charge is insufficient to turn over engine, recharge battery.

Battery Maintenance

Regular maintenance is necessary to prolong battery life.

Battery Test

To test battery, follow manufacturer's instructions.

ELECTRONIC IGNITION SYSTEMS

Ignition System Components

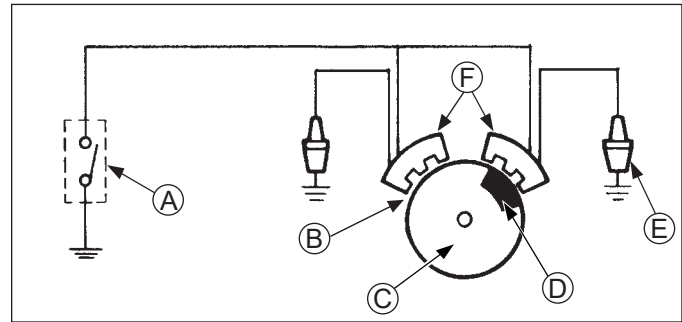

A	Kill Switch/ Off Position of Key Switch	B	Air Gap
C	Flywheel	D	Magnet
E	Spark Plug	F	Ignition Modules

There are 2 different types of ignition systems used on these engines. All systems use an ignition module which energizes spark plug. Difference in systems is in way ignition timing is triggered.

Both ignition systems are designed to be trouble free for life of engine. Other than periodically checking/replacing spark plugs, no maintenance or timing adjustments are necessary or possible. Mechanical systems do occasionally fail or break down. Refer to Troubleshooting to determine root of a reported problem.

Reported ignition problems are most often due to poor connections. Before beginning test procedure, check all external wiring. Be certain all ignition-related wires are connected, including spark plug leads. Be certain all terminal connections fit snugly. Make sure ignition switch is in run position.

Electrical System

Ignition Systems

These systems use a capacitive discharge (CD) coil. With CDI fixed timing, ignition timing and spark remains constant regardless of engine speed. Timing of spark is controlled by location of flywheel magnet group as referenced to engine TDC. MDI adjustable timing uses a digital microprocessor which is located in ignition modules. Ignition timing varies depending upon engine speed with this system.

A typical ignition system consists of:

- 1 magnet assembly which is permanently affixed to flywheel.
- 2 electronic capacitive-discharge ignition modules which mount on engine crankcase.
- 1 kill switch (or key switch) which grounds modules to stop engine.
- 2 spark plugs.

A	Spark Plug(s)	B	Oil Pressure Switch	C	Oil Sentry™ (Green)	D	White Kill
E	Flywheel Stator Assembly	F	Ignition Module	G	Non-Smart Spark™ Ignition	H	Rectifier-Regulator Connector
I	Rectifier-Regulator	J	Oil Sentry™ Kill (Green)	K	Violet B+	L	Solenoid Shift Starter Assembly
M	Starter Solenoid Tang	N	Starter Solenoid Stud	O	Fuse	P	Blue
Q	Alternate Ignition Kill (-)	R	White	S	Accessory Terminal (+)	T	Yellow
U	Ignition Kill	V	Red	W	Carburetor	X	Carburetor Solenoid
Y	Black (Ground)	Z	Intake Manifold Screw	AA	Black	AB	Oil Sentry™ Panel Light/Remote Light
AC	Oil Sentry™ Light	AD	Connector	AE	Magneto	AF	Key Switch
AG	Accessory	AH	Battery	AI	Starter	AJ	Ground
AK	Key Switch Ground	AL	Rectifier	AM	Blue/Red	AN	Battery Positive
AO	Battery Negative						

Electronic Ignition Systems Tests

NOTE: Ignition tester must be used to test ignition on these engines. Use of any other tester can result in inaccurate findings. Battery on unit must be fully charged and properly connected before performing tests (a battery that is hooked up or charged backward will crank engine but it won't have spark). Be certain drive is in neutral and all external loads are disconnected.

Test Ignition Systems

NOTE: If engine starts or runs during testing, you may need to ground kill lead to shut it down. Because you have interrupted kill circuit, it may not stop using switch.

Isolate and verify trouble is within engine.

1. Locate connectors where wiring harnesses from engine and equipment are joined. Separate connectors and remove white kill lead from engine connector. Rejoin connectors and position or insulate kill lead terminal so it cannot touch ground. Try to start engine to verify whether reported problem is still present.

Condition	Possible Cause	Conclusion
Problem goes away.	Electrical System	Check key switch, wires, connections, safety interlocks, etc.
Problem persists.	Ignition or Electrical System	Leave kill lead isolated until all testing is completed. Identify white kill lead of engine wiring harness connector. Establish a connection to a known good ground location. Engine should kill completely. If not or only one cylinder is affected, check ignition modules and white kill lead connection for affected module.

Test for Spark

NOTE: If 2 testers are available, testing can be performed simultaneously for both cylinders. However, if only 1 tester is available, 2 individual tests must be performed. Side not being tested must have spark plug lead connected or grounded. Do not crank engine or perform tests with 1 spark plug lead disconnected and not grounded, or permanent system damage may occur.

1. With engine stopped, disconnect 1 spark plug lead. Connect spark plug lead to post terminal of spark tester and attach tester clip to a good engine ground.
2. Crank engine over, establishing a minimum of 350-450 RPM, and observe tester(s) for spark.
3. Repeat spark test on opposite cylinder if cylinders are being tested individually.

Condition	Possible Cause	Conclusion
Both cylinders have good spark but engine runs poorly or existing plug condition is questionable.	Spark Plug(s)	Install new spark plug(s) and retest engine performance.
1 cylinder has good spark and other cylinder has no or intermittent spark.	Ignition	Test ignition modules and connections.
Spark on both cylinders but power is suspect.	Sheared Flywheel Key	Check for broken key.

Check Ignition Modules and Connections

1. Remove blower housing from engine. Inspect kill wire for any damage, cuts, or shorts to engine or ignition module body. Check that connections are oriented properly on terminals of modules.
2. On MDI adjustable timing engines, ensure that both modules are correctly installed with flat side of module out/ towards you.

Condition	Possible Cause	Conclusion
All checks are OK but module has no spark or fails to advance.	Ignition Module	Replace affected module.

BATTERY CHARGING SYSTEM

NOTE: Observe following guidelines to avoid damage to electrical system and components:

- Make sure battery polarity is correct. A negative (–) ground system is used.
- Disconnect rectifier-regulator plug and/or wiring harness plug before doing any electric welding on equipment powered by engine. Disconnect all other electrical accessories in common ground with engine.
- Prevent stator (AC) leads from touching or shorting while engine is running. This could damage stator.

Most engines are equipped with a 15 or 20 amp regulated charging system. Some have a 25 amp regulated charging system.

15/20/25 Amp Regulated Charging System

Stator

Stator is mounted on crankcase behind flywheel. Follow procedures in Disassembly and Reassembly if stator replacement is necessary.

Rectifier-Regulator

NOTE: When installing rectifier-regulator, take note of terminal markings and install plug(s) accordingly.

NOTE: Disconnect all electrical connections attached to rectifier-regulator. Testing may be performed with rectifier-regulator mounted or loose. Repeat applicable test procedure 2 or 3 times to determine condition of part.

Rectifier-regulator is mounted on blower housing. To replace it, disconnect plug(s), remove two mounting screws, and ground wire or metal grounding strap.

Testing of rectifier-regulator may be performed as follows, using appropriate Rectifier-Regulator Tester.

To test 15 amp rectifier-regulators:

1. Connect tester ground lead (with spring clamp) to body of rectifier-regulator being tested.
2. Connect tester red lead to B+ terminal of rectifier-regulator and 2 black tester leads to 2 AC terminals.
3. Plug tester into proper AC outlet/power for tester being used. Turn on power switch. POWER light should be illuminated and 1 of 4 status lights may be on as well. This does not represent condition of part.
4. Press TEST button until a click is heard and then release. Momentarily 1 of 4 status lights will illuminate, indicating condition of part.

Electrical System

To test 20/25 amp rectifier-regulators:

1. 20 amp: Connect single lead adapter in between B+ (center) terminal of rectifier-regulator being tested and squared single end of tandem adapter lead.
25 amp: Connect squared single end of tandem lead adapter to B+ (center/red) lead of rectifier-regulator being tested.
2. Connect tester ground lead (with spring clamp) to body of rectifier-regulator.
3. Connect red lead and 1 of black leads to pair of terminals on open end of tandem adapter lead (connections are not location specific).
4. Connect remaining black lead from tester to 1 of outer AC terminals on rectifier-regulator.
5. Plug tester into proper AC outlet/power for tester being used. Turn on power switch. POWER light should be illuminated and 1 of 4 status lights may be on as well. This does not represent condition of part.
6. Press TEST button until a click is heard and then release. Momentarily 1 of 4 status lights will illuminate indicating partial condition of part.

Condition	Conclusion			
	4 amp	15 Amp	20 amp	25 amp
OK (green) or HIGH light comes on and stays steady.	Part is good and may be used.		Disconnect tester black lead attached to 1 AC terminal and reconnect it to other AC terminal. Repeat test. If OK (green) light comes on again, part is good and may be used.	
NOTE: A flashing LOW light can also occur as a result of an inadequate ground lead connection. Make certain connection location is clean and clamp is secure. Other lights come on.	Rectifier-regulator is faulty and should not be used.			

15/20/25 Amp Battery Charging Systems

NOTE: Always zero ohmmeter on each scale before testing to ensure accurate readings. Voltage tests should be made with engine running at 3600 RPM with no load. Battery must be good and fully charged.

When problems occur in keeping battery charged or battery charges at high rate, charging system or battery might be causing problems.

To test charging system for no charge to battery:

1. Insert an ammeter in B+ lead from rectifier-regulator. With engine running at 3600 RPM and B+ (at terminal on rectifier-regulator) to ground using a DC voltmeter.

If voltage is 13.8 volts or more, place a minimum load of 5 amps (turn on lights if 60 watts or more, or place a 2.5 ohm, 100 watt resistor across battery terminals) on battery to reduce voltage. Observe ammeter.

Condition	Conclusion
Charge rate increases when load is applied.	Charging system is OK and battery was fully charged.
Charge rate does not increase when load is applied.	Test stator and rectifier-regulator (steps 2 and 3).

2. Remove connector from rectifier-regulator. With engine running at 3600 RPM, measure AC voltage across stator leads using an AC voltmeter.

Condition	Conclusion
Voltage is 28 volts or more.	Stator is OK. Rectifier-regulator is faulty; replace.
Voltage is less than 28 volts.	Stator is faulty; replace. Test stator further using an ohmmeter (steps 3 and 4).

3. With engine stopped, measure resistance across stator leads using an ohmmeter.

Condition	Conclusion
Resistance is 0.1/0.2 ohms.	Stator is OK.
Resistance is 0 ohms.	Stator is shorted; replace.
Resistance is infinity ohms.	Stator is open; replace.

4. With engine stopped, measure resistance from each stator lead to ground using an ohmmeter.

Condition	Conclusion
Resistance is infinity ohms (no continuity).	Stator is OK (not shorted to ground).
Resistance (or continuity) measured.	Stator leads are shorted to ground; replace.

To test charging system for battery continuously charging at high rate:

1. With engine running at 3600 RPM, measure voltage from B+ lead to ground using a DC voltmeter.

Condition	Conclusion
Voltage is 14.7 volts or less.	Charging system is OK. Battery is unable to hold charge; service or replace.
Voltage is more than 14.7 volts.	Faulty rectifier-regulator; replace.

Starter System

NOTE: Do not crank engine continuously for more than 10 seconds. Allow a 60 second cool down period between starting attempts. Failure to follow these guidelines can burn out starter motor.

NOTE: If engine develops sufficient speed to disengage starter but does not keep running (a false start), engine rotation must be allowed to come to a complete stop before attempting to restart engine. If starter is engaged while flywheel is rotating, starter pinion and flywheel ring gear may clash and damage starter.

NOTE: If starter does not crank engine, shut off starter immediately. Do not make further attempts to start engine until condition is corrected.

NOTE: Do not drop starter or strike starter frame. Doing so can damage starter.

Engines in this series use solenoid shift starters.

Troubleshooting-Starting Difficulties

Condition	Possible Cause	Conclusion
Starter does not energize.	Battery	Check specific gravity of battery. If low, recharge or replace battery as necessary.
	Wiring	Clean corroded connections and tighten loose connections. Replace wires in poor condition and with frayed or broken insulation.
	Starter Switch or Solenoid	By-pass switch or solenoid with a jumper wire. If starter cranks normally, replace faulty components. Remove and perform individual solenoid test procedure.
Starter energizes but turns slowly.	Battery	Check specific gravity of battery. If low, recharge or replace battery as necessary.
	Brushes	Check for excessively dirty or worn brushes and commutator. Clean using a coarse cloth (not emery cloth). Replace brushes if excessively or unevenly worn.
	Transmission or Engine	Make sure clutch or transmission is disengaged or placed in neutral. This is especially important on equipment with hydrostatic drive. Transmission must be exactly in neutral to prevent resistance which could keep engine from starting. Check for seized engine components such as bearings, connecting rod, and piston.

SOLENOID SHIFT ELECTRIC STARTERS

Solenoid Shift Starter Components

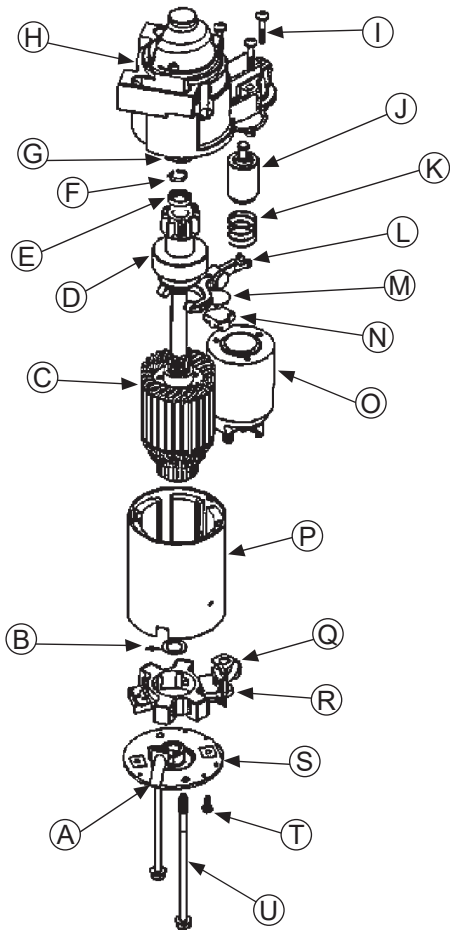

A	Tube	B	Washer
C	Armature	D	Drive
E	Stop	F	Retaining Ring
G	Collar	H	Drive End Cap
I	Screw	J	Plunger
K	Spring	L	Lever
M	Plate	N	Plug
O	Solenoid	P	Frame and Field
Q	Brush Holder	R	Nut
S	Commutator End Plate	T	Screw
U	Bolt		

When power is applied to starter electric solenoid moves drive pinion out onto drive shaft and into mesh with flywheel ring gear. When pinion reaches end of drive shaft it rotates flywheel and cranks engine.

When engine starts and start switch is released, starter solenoid is deactivated, drive lever moves back, and drive pinion moves out of mesh with ring gear into retracted position.

Starter Disassembly

NOTE: Do not reuse old retainer.

NOTE: Do not soak armature or use solvent when cleaning. Wipe clean using a soft cloth, or use compressed air.

1. Remove hex nut and disconnect positive (+) brush lead/bracket from solenoid terminal.
2. Remove head screws securing solenoid to starter.
3. If solenoid was mounted with Phillips head screws, separate solenoid and plunger spring from drive end cap. If solenoid was mounted with external Torx head screws, plunger is part of solenoid, unhook plunger pin from drive lever. Remove gasket from recess in housing.
4. Remove thru (larger) bolts.
5. Remove commutator end plate assembly, containing brush holder, brushes, springs, and locking caps. Remove thrust washer from inside commutator end.
6. Remove frame from armature and drive end cap.
7. Remove drive lever pivot bushing and backing plate from end cap.
8. Take out drive lever and pull armature out of drive end cap.
9. Remove thrust washer from armature shaft.
10. Push stop collar down to expose retaining ring.
11. Remove retainer from armature shaft. Save stop collar.
12. Remove drive pinion assembly from armature.
13. Clean parts as required.

Inspection

Check drive pinion and inspect following areas:

- Pinion teeth for abnormal wear or damage.
- Surface between pinion and clutch mechanism for nicks or irregularities which could cause seal damage.
- Check drive clutch by holding clutch housing and rotating pinion. Pinion should rotate in only 1 direction.

Brushes and Springs

Detail

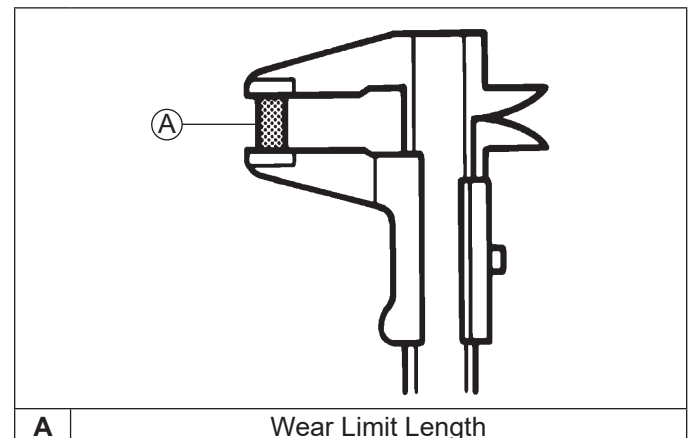

A Wear Limit Length

Inspect both springs and brushes for wear, fatigue, or damage. Measure length of each brush. Minimum length for each brush is 7.6 mm (0.300 in.). Replace brushes if they are worn, undersize, or condition is questionable.

Starter System

Armature Components and Details

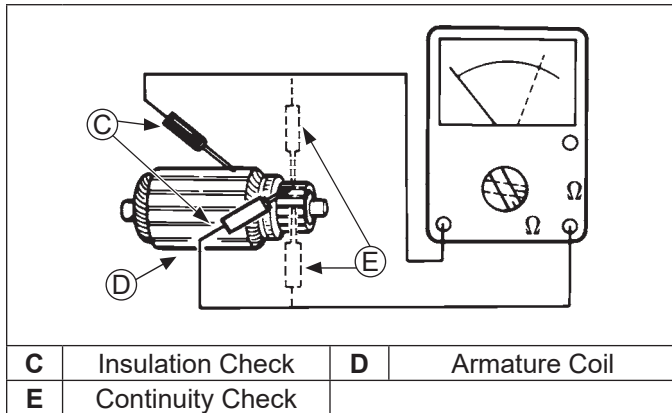
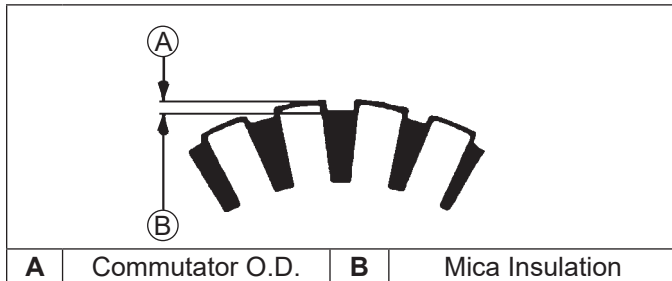

1. Clean and inspect commutator (outer surface). Mica insulation must be lower than commutator bars (undercut) to ensure proper operation of commutator.
2. Use an ohmmeter set to Rx1 scale. Touch probes between 2 different segments of commutator, and check for continuity. Test all segments. Continuity must exist between all or armature is bad.
3. Check for continuity between armature coil segments and commutator segments. There should be no continuity. If continuity exists between any 2 armature is bad.
4. Check armature windings/insulation for shorting.

Shift Fork

Check that shift fork is complete, and pivot and contact areas are not excessively worn, cracked, or broken.

Brush Replacement

4 brushes and springs are serviced as a set. Use a new Rehlko brush and spring kit if replacement is necessary.

1. Perform steps 1-5 in Starter Disassembly.
2. Remove screws securing brush holder assembly to end cap (plate). Note orientation for reassembly later. Discard old brush holder assembly.
3. Clean component parts as required.
4. New brushes and springs come preassembled in a brush holder with a protective sleeve that will also serve as an installation tool.
5. Perform Steps 10-13 in Starter Reassembly sequence. Installation must be done after armature, drive lever, and frame are installed, if starter has been disassembled.

Starter Reassembly

NOTE: Always use a new retainer. Do not reuse old retainers that have been removed.

NOTE: Correctly installed, center pivot section of drive lever will be flush or below machined surface of housing.

1. Apply drive lubricant to armature shaft splines. Install drive pinion onto armature shaft.
2. Install and assemble stop collar/retainer assembly.
 - a. Install stop collar down onto armature shaft with counter bore (recess) up.
 - b. Install a new retainer in larger (rear) groove of armature shaft. Squeeze with a pliers to compress it in groove.
 - c. Slide stop collar up and lock it into place, so recess surrounds retainer in groove. If necessary, rotate pinion outward on armature splines against retainer to help seat collar around retainer.
3. Install offset thrust (stop) washer so smaller offset of washer faces retainer/collar.
4. Apply a small amount of oil to bearing in drive end cap, and install armature with drive pinion.
5. Lubricate fork end and center pivot of drive lever with drive lubricant. Position fork end into space between captured washer and rear of pinion.
6. Slide armature into drive end cap and at same time seat drive lever into housing.
7. Install backup washer, followed by rubber grommet, into matching recess of drive end cap. Molded recesses in grommet should be out, matching and aligned with those in end cap.
8. Install frame, with small notch forward, onto armature and drive end cap. Align notch with corresponding section in rubber grommet. Install drain tube in rear cutout, if it was removed previously.
9. Install flat thrust washer onto commutator end of armature shaft.
10. Starter reassembly when replacing brushes/brush holder assembly:
 - a. Hold starter assembly vertically on end housing, and carefully position assembled brush holder assembly, with supplied protective tube, against end of commutator/armature. Mounting screw holes in metal clips must be up/out. Slide brush holder assembly down into place around commutator, and install positive (+) brush lead grommet in cutout of frame. Protective tube may be saved and used for future servicing.

Starter reassembly when not replacing brushes/brush holder assembly:

- a. Carefully unhook retaining caps from brush assemblies. Do not lose springs.

- b. Position brushes back in their slots so they are flush with I.D. of brush holder assembly. Insert brush installation tool (with extension), or use tube described above from a prior brush installation, through brush holder assembly, so holes in metal mounting clips are up/out.
 - c. Install brush springs and snap on retainer caps.
 - d. Hold starter assembly vertically on end housing, and carefully place tool (with extension) and assembled original brush holder assembly onto end of armature shaft. Slide brush holder assembly down into place around commutator, install positive (+) brush lead grommet in cutout of frame.
11. Install end cap onto armature and frame, aligning thin raised rib in end cap with corresponding slot in grommet of positive (+) brush lead.
 12. Install thru bolts and brush holder mounting screws. Torque bolts to 5.6-9.0 N·m (49-79 in. lb.) and brush holder mounting screws to 2.5-3.3 N·m (22-29 in. lb.).
 13. Hook plunger behind upper end of drive lever and install spring into solenoid. Insert mounting screws through holes in drive end cap. Use these to hold solenoid gasket in position, then mount solenoid. Torque screws to 4.0-6.0 N·m (35-53 in. lb.).
 14. Connect positive (+) brush lead/bracket to solenoid and secure with nut. Torque nut to 8-11 N·m (71-97 in. lb.). Do not overtighten.

Solenoid Tests

NOTE: DO NOT leave 12 volt test leads connected to solenoid for any time over what is necessary for performing each of individual tests. Internal damage to solenoid may occur.

Disconnect all leads from solenoid including positive brush lead attached to lower stud terminal. Remove mounting hardware and separate solenoid from starter for testing.

To test solenoid pull-in coil/plunger:

Actuation

1. Use a 12 volt power supply and 2 test leads.
2. Connect 1 lead to flat spade S/start terminal on solenoid. Momentarily connect other lead to lower large post terminal.

When connection is made solenoid should energize (audible click) and plunger retract. Repeat test several times.

Continuity

1. Use an ohmmeter set to audible or Rx2K scale, and connect 2 ohmmeter leads to 2 large post terminals.
2. Perform solenoid pull-in coil/plunger actuation test and check for continuity. Ohmmeter should indicate continuity. Repeat test several times.

To test solenoid hold-in coil:

Function

1. Connect a 12 volt test lead to flat spade S/start terminal on solenoid and other lead to body or mounting surface of solenoid.
2. Manually push plunger IN and check if coil holds plunger retracted. Do not allow test leads to remain connected to solenoid for a prolonged period of time.

Continuity

1. Use an ohmmeter set to audible or Rx2K scale, and connect 2 ohmmeter leads to 2 large post terminals.
2. Perform preceding solenoid hold-in coil function test and check for continuity. Meter should indicate continuity. Repeat test several times.

Condition	Conclusion
Solenoid fails to activate.	Replace solenoid.
No continuity is indicated.	
Plunger fails to stay retracted.	

Disassembly/Inspection and Service

	⚠ WARNING	Before working on engine or equipment, disable engine as follows: 1) Disconnect spark plug lead(s). 2) Disconnect negative (-) battery cable from battery.
	Accidental Starts can cause severe injury or death. Disconnect and ground spark plug lead(s) before servicing.	

External Engine Components

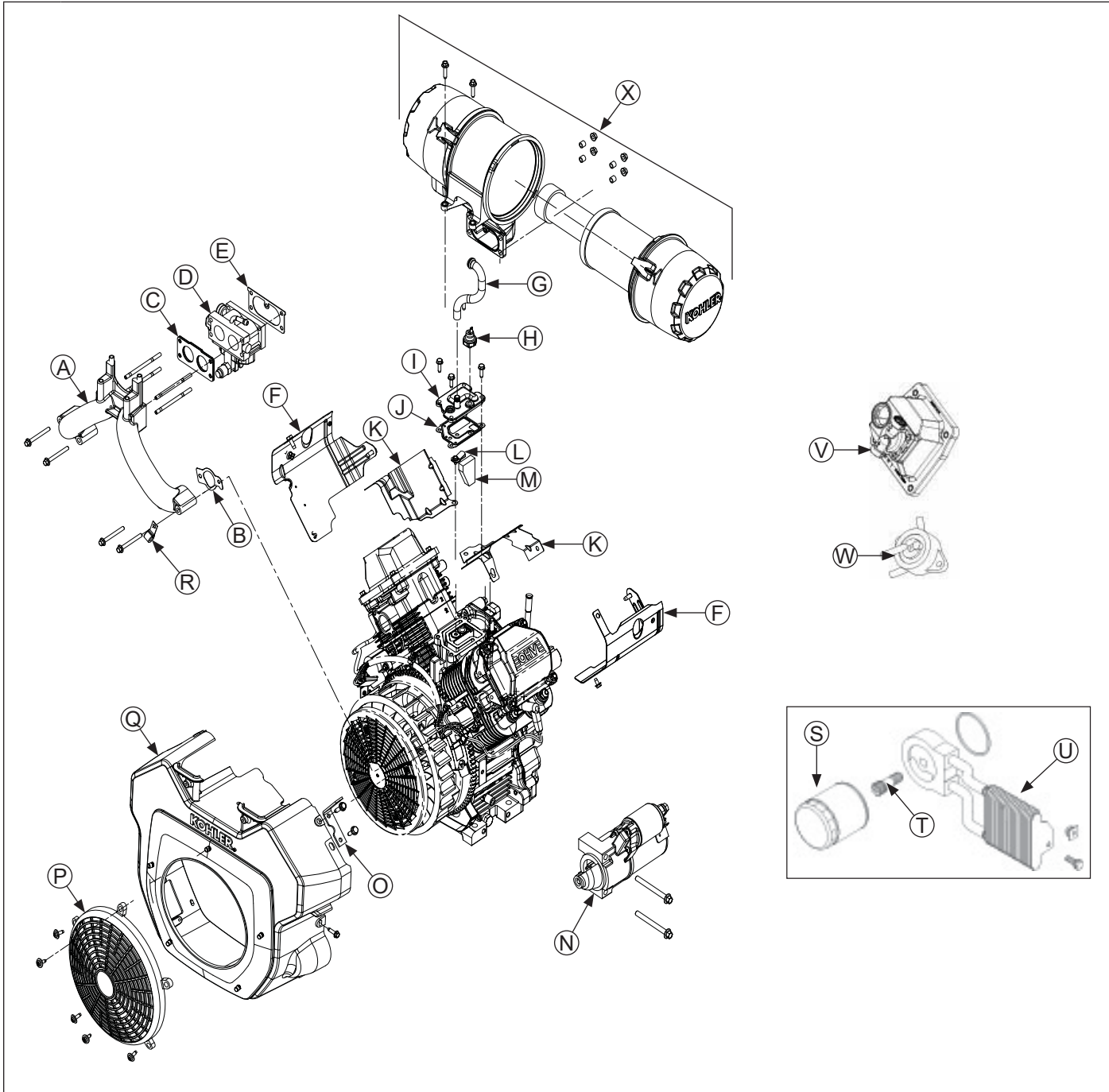

A	Intake Manifold	B	Intake Manifold Gasket	C	Carburetor Gasket	D	Carburetor
E	Air Cleaner Gasket	F	Outer Baffle	G	Breather Tube	H	Oil Sentry™
I	Breather Cover	J	Breather Gasket	K	Inner Baffle	L	Breather Reed

M	Filter	N	Electric Starter	O	Lifting Bracket	P	Fixed Guard
Q	Blower Housing	R	Wire Clip	S	Oil Filter	T	Nipple
U	Oil Cooler	V	Valve Cover Fuel Pump	W	Pulse Fuel Pump	X	Air Cleaner

Clean all parts thoroughly as engine is disassembled. Only clean parts can be accurately inspected and gauged for wear or damage. There are many commercially available cleaners that will quickly remove grease, oil, and grime from engine parts. When such a cleaner is used, follow manufacturer's instructions and safety precautions carefully.

Make sure all traces of cleaner are removed before engine is reassembled and placed into operation. Even small amounts of these cleaners can quickly break down lubricating properties of engine oil.

Disconnect Spark Plug Leads

NOTE: Pull on boot only, to prevent damage to spark plug lead.

1. Disconnect leads from spark plugs.
2. Shut off fuel supply.

Drain Oil from Crankcase and Remove Oil Filter

1. Remove oil fill cap, dipstick, and 1 oil drain plug.
2. Allow ample time for oil to drain from crankcase and oil filter.
3. Remove and discard oil filter.
4. An oil cooler is standard equipment on some models and an option on others.

Remove Muffler

Remove exhaust system and attaching hardware from engine. On engines equipped with a port liner, remove it now.

Remove Air Cleaner Assembly

1. Disconnect breather hose from fitting in adapter or elbow.
2. Remove nuts securing adapter or elbow.
3. Remove screws securing main support bracket for air cleaner to valve covers. Remove mounting screws into top of intake manifold. Unhook choke return spring if equipped. Do not lose any hardware.
4. Remove air cleaner as an assembly from engine.

Remove Fuel Pump

	⚠ WARNING
	Explosive Fuel can cause fires and severe burns. Do not fill fuel tank while engine is hot or running.
Gasoline is extremely flammable and its vapors can explode if ignited. Store gasoline only in approved containers, in well ventilated, unoccupied buildings, away from sparks or flames. Spilled fuel could ignite if it comes in contact with hot parts or sparks from ignition. Never use gasoline as a cleaning agent.	

Pulse Style Pumps

1. Disconnect fuel lines at carburetor and at in-line fuel filter.
2. Disconnect pulse (vacuum) line from crankcase.
3. Remove screws securing fuel pump to blower housing.
4. Note or mark orientation of fuel pump, then remove fuel pump with lines attached.

Mechanical Fuel Pump

A mechanical style fuel pump is part of valve cover assembly.

1. Disconnect fuel lines at pump outlet and at in-line fuel filter.
2. Fuel pump will be removed with valve cover. Refer to valve cover removal procedure.

Remove Control Panel (if equipped)

1. Disconnect Oil Sentry™ indicator light wires.
2. Disconnect choke control cable from control bracket.
3. Disconnect throttle control cable or shaft.
4. Remove panel from blower housing.

Disassembly/Inspection and Service

Remove Throttle and Choke Controls

Control Bracket Components

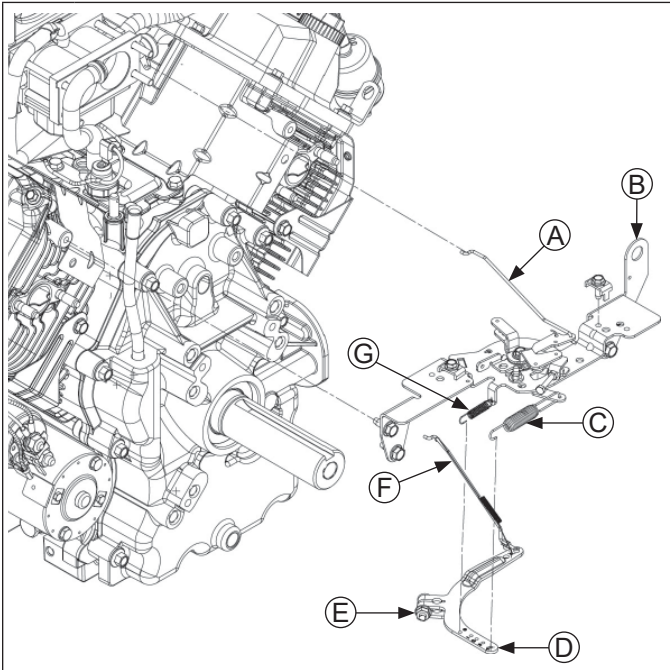

A	Choke Linkage	B	Control Bracket
C	Governor Spring	D	Governor Lever
E	Nut	F	Throttle Linkage
G	Governed Idle Spring		

1. Remove screws securing control bracket and rear air cleaner bracket (some models) to cylinder heads.
2. Mark spring hole locations and disconnect spring from governor lever.
3. Remove choke linkage from choke actuator lever and carburetor.

Remove External Governor Controls

Loosen nut and remove governor lever from cross shaft. Leave lever attached to throttle linkage and lay assembly on top of crankcase.

Remove Carburetor

	⚠ WARNING
	Explosive Fuel can cause fires and severe burns. Do not fill fuel tank while engine is hot or running.
Gasoline is extremely flammable and its vapors can explode if ignited. Store gasoline only in approved containers, in well ventilated, unoccupied buildings, away from sparks or flames. Spilled fuel could ignite if it comes in contact with hot parts or sparks from ignition. Never use gasoline as a cleaning agent.	

1. Disconnect fuel shut-off solenoid lead and ground lead, if equipped.

2. If required use nuts locked together and remove carburetor mounting studs on starter side of intake manifold and one stud on oil filter side.

Pivot carburetor to clear breather cover fitting and pressure switch (if equipped). Remove carburetor, throttle linkage, choke linkage, and governor lever as an assembly.

3. Remove carburetor, throttle linkage and governor lever as an assembly.
4. Remove carburetor gasket.
5. If necessary, carburetor, throttle linkage and governor lever can be separated. Reattach bushings to linkage following separation to avoid losing them.

Remove Oil Sentry™ (if equipped)

1. Disconnect lead from Oil Sentry™ switch.
2. Remove Oil Sentry™ switch from breather cover.

Remove Electric Starter Motor

1. Disconnect leads from starter.
2. Remove screws and starter assembly.

Remove Outer Baffles and Blower Housing

1. Disconnect plug from rectifier-regulator on blower housing.
2. Use tip of dipstick or a similar small flat tool to bend locking tang, then remove B+ (center lead) from terminal plug as shown. This will allow blower housing to be removed without disturbing wiring harness.
3. Rectifier-regulator does not have to be detached from blower housing.
4. Remove screws securing outer baffles. Note location of any lifting strap and position of two short screws (one each side on bottom) for reassembly.
5. Remove outer baffles on both sides.
6. Remove debris screen before removing blower housing.
7. Remove lower blower housing screw and washer securing rectifier-regulator ground lead or grounding strap.
8. Remove remaining screws and detach blower housing.
9. Disconnect plug from key switch in blower housing if engine is equipped.

Remove Inner Baffles and Breather Cover

Inner (valley) baffles are attached at one corner using same fasteners as breather cover.

1. Remove screws securing inner baffles.
2. Remove both inner baffles.
3. Remove two remaining screws holding breather cover to crankcase.
4. Remove breather cover and gasket.
5. Remove breather filter from chamber.
6. Remove screw, breather reed retainer and breather reed.

Remove Intake Manifold

1. Remove screws securing intake manifold to cylinder heads. Note which screws hold wiring clamps.
2. Remove intake manifold and intake manifold gaskets.
3. Leave wiring harness attached to manifold.

Remove Valve Covers

1. Remove screws securing each valve cover. Note position of any attached brackets or lifting straps.
2. Remove valve covers, O-rings, and any brackets or lifting straps. Note which side of engine has oil fill and or fuel pump valve cover.

Cylinder Head Components

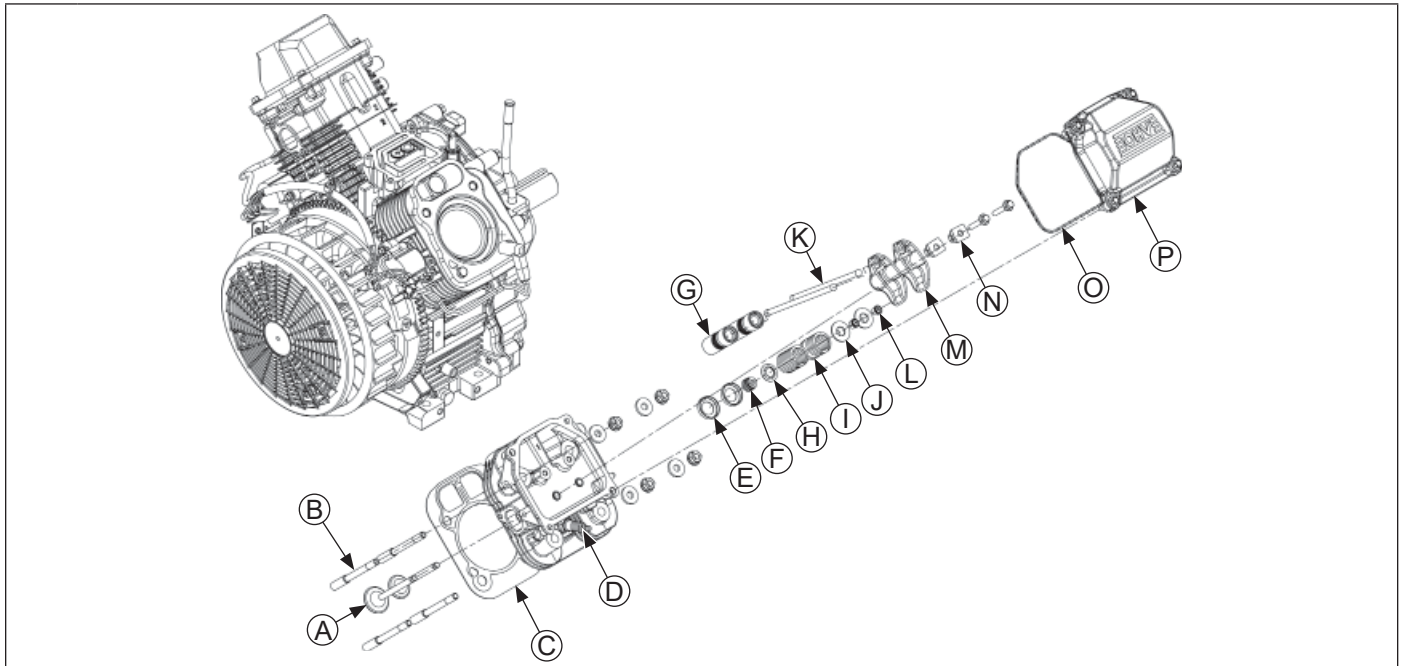

A	Valve	B	Stud	C	Gasket	D	Spark Plug
E	Cap	F	Valve Stem Seal	G	Hydraulic Lifter	H	Retainer
I	Valve Spring	J	Valve Spring Retainer	K	Push Rod	L	Valve Keeper
M	Rocker Arm	N	Rocker Arm Pivot	O	Valve Cover O-ring	P	Valve Cover

Remove Spark Plugs

Remove spark plug from each cylinder head.

Remove Cylinder Heads and Hydraulic Lifters

NOTE: Cylinder heads are retained using either screws or nuts and washers on studs. Do not interchange or mix components, as cylinder heads may have different machining, unique to each fastening method.

NOTE: Exhaust lifters are located on output shaft side of engine while intake lifters are located on fan side of engine. Cylinder head number is embossed on outside of each cylinder head.

1. Remove screws or nuts and washers securing each cylinder head. Unless screws are damaged or questionable, they can be reused. Discard nuts and washers once removed; do not reuse. Studs (if present) should only be removed if damaged or if cylinder reconditioning is necessary. Once removed, they must be replaced.

2. Mark position of push rods as either intake or exhaust and cylinder 1 or 2. Push rods should always be reinstalled in same positions.
3. Carefully remove push rods, cylinder heads and head gaskets.
4. Remove lifters from lifter bores. Use a Hydraulic Lifter Tool. Do not use a magnet to remove lifters. Mark lifters by location, as either intake or exhaust and cylinder 1 or 2. Hydraulic lifters should always be reinstalled in same position.

Disassembly/Inspection and Service

Disassemble Cylinder Heads

NOTE: These engines use valve stem seals on intake valves. Use a new seal whenever valve is removed or if seal is deteriorated in any way. Never reuse an old seal.

1. Remove screws, rocker arm pivots and rocker arms from cylinder head. Note screw color for reassembly.
2. Compress valve springs using a valve spring compressor.

3. Once valve spring is compressed, remove following items.
 - Valve spring keepers.
 - Valve spring retainers.
 - Valve springs.
 - Valve spring caps.
 - Intake and exhaust valves (mark position).
 - Valve stem seals (intake valve only).
4. Repeat above procedure for other cylinder head. Do not interchange parts from one cylinder head to other.

Inspection and Service Valve Details

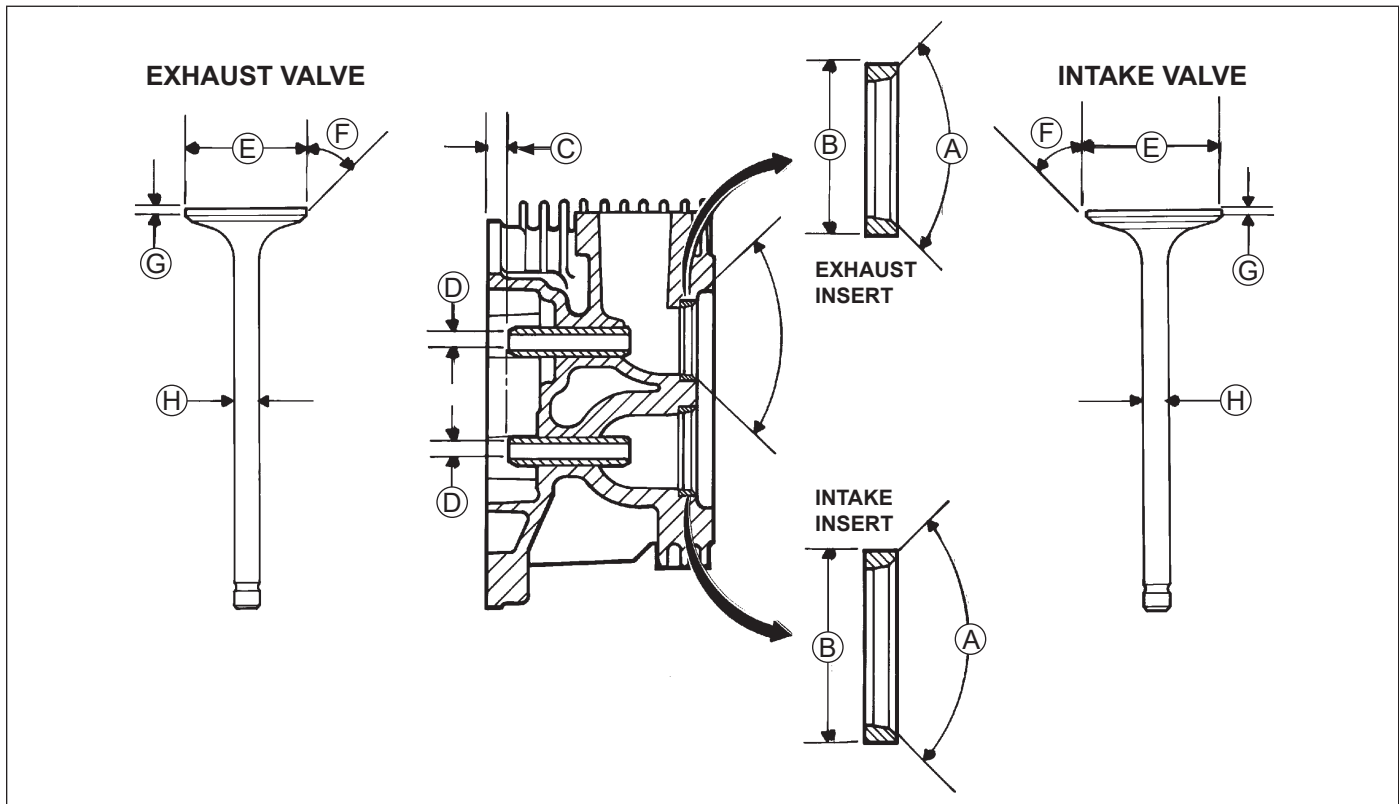

Dimension		Intake	Exhaust
A	Seat Angle	89°	89°
B	Insert O.D.	36.987/37.013 mm (1.4562/1.4572 in.)	32.987/33.013 mm (1.2987/1.2997 in.)
C	Guide Depth	4 mm (0.1575 in.)	6.5 mm (0.2559 in.)
D	Guide I.D.	7.038/7.058 mm (0.2771/0.2779 in.)	7.038/7.058 mm (0.2771/0.2779 in.)
E	Valve Head Diameter	33.37/33.63 mm (1.3138/1.3240 in.)	29.37/29.63 mm (1.1563/1.1665 in.)
F	Valve Face Angle	45°	45°
G	Valve Margin (Min.)	1.5 mm (0.0591 in.)	1.5 mm (0.0591 in.)
H	Valve Stem Diameter	6.982/7.000 mm (0.2749/0.2756 in.)	6.970/6.988 mm (0.2744/0.2751 in.)

After cleaning, check flatness of cylinder head and corresponding top surface of crankcase, using a surface plate or precision straight edge and feeler gauge. Maximum allowable out of flatness is:

0.076 mm (0.003 in.) for 80 mm bores;

0.1 mm (0.003 in.) for 83 mm bore.

Carefully inspect valve mechanism parts. Inspect valve springs and related hardware for excessive wear or distortion. Check valves and valve seat area or inserts for evidence of deep pitting, cracks, or distortion. Check clearance of valve stems in guides.

Hard starting or loss of power accompanied by high fuel consumption may be symptoms of faulty valves. Although these symptoms could also be attributed to worn rings, remove and check valves first. After removal, clean valve heads, faces, and stems with a power wire brush.

Then, carefully inspect each valve for defects such as a warped head, excessive corrosion, or a worn stem end. Replace valves found to be in bad condition.

Valve Guides

If a valve guide is worn beyond specifications, it will not guide valve in a straight line. This may result in burnt valve faces or seats, loss of compression, and excessive oil consumption.

To check valve guide-to-valve stem clearance, thoroughly clean valve guide and, using a split-ball gauge, measure inside diameter of guide. Then, using an outside micrometer, measure diameter of valve stem at several points on stem where it moves in valve guide. Use largest stem diameter to calculate clearance by subtracting stem diameter from guide diameter. If intake clearance exceeds 0.038/0.076 mm (0.0015/0.0030 in.) or exhaust clearance exceeds 0.050/0.088 mm (0.0020/0.0035 in.), determine whether valve stem or guide is responsible for excessive clearance.

Maximum (I.D.) wear on intake valve guide is 7.134 mm (0.2809 in.) while 7.159 mm (0.2819 in.) is maximum allowed on exhaust guide. Guides are not removable but can be reamed 0.25 mm (0.010 in.) oversize. Valves with 0.25 mm oversize stems must then be used.

If guides are within limits but valve stems are worn beyond limits, install new valves.

Valve Seat Inserts

Hardened steel alloy intake and exhaust valve seat inserts are press fitted into cylinder head. Inserts are not replaceable but can be reconditioned if not too badly pitted or distorted. If cracked or badly warped, cylinder head should be replaced.

Recondition valve seat inserts following instructions provided with valve seat cutter being used. Final cut should be made with an 89° cutter as specified for valve seat angle. Cutting proper 45° valve face angle as specified, and proper valve seat angle (44.5°, half of full 89° angle), will achieve desired 0.5° (1.0° full cut) interference angle where maximum pressure occurs on outside diameters of valve face and seat.

Lapping Valves

NOTE: Exhaust valves that are black in color cannot be ground and do not require lapping.

Reground or new valves must be lapped in, to provide proper fit. Use a hand valve grinder with a suction cup for final lapping. Lightly coat valve face with a fine grade of grinding compound, then rotate valve on its seat with grinder. Continue grinding until a smooth surface is obtained on seat and on valve face. Thoroughly clean cylinder head in soap and hot water to remove all traces of grinding compound. After drying cylinder head, apply a light coating of SAE 10 oil to prevent rusting.

Intake Valve Stem Seal

These engines use valve stem seals on intake valves. Always use a new seal when valves are removed from cylinder head. Seals should also be replaced if deteriorated or damaged in any way. Never reuse an old seal.

Hydraulic Lifters Inspection

Check base surface of hydraulic lifters for wear or damage. If lifters need to be replaced, apply a liberal coating of Rehlko lubricant to base of each new lifter before it is installed.

Bleeding Lifters

To prevent a possible bent push rod or broken rocker arm, it is important to bleed any excess oil out of lifters before they are installed.

1. Cut a 50-75 mm (2-3 in.) piece from end of an old push rod and chuck it in a drill press.
2. Lay a rag or shop towel on table of drill press and place lifter, open end up, on towel.
3. Lower chucked push rod until it contacts plunger in lifter. Slowly pump plunger 2 or 3 times to force oil out of feed hole in side of lifter.

Disassembly/Inspection and Service

Flywheel/Ignition Components

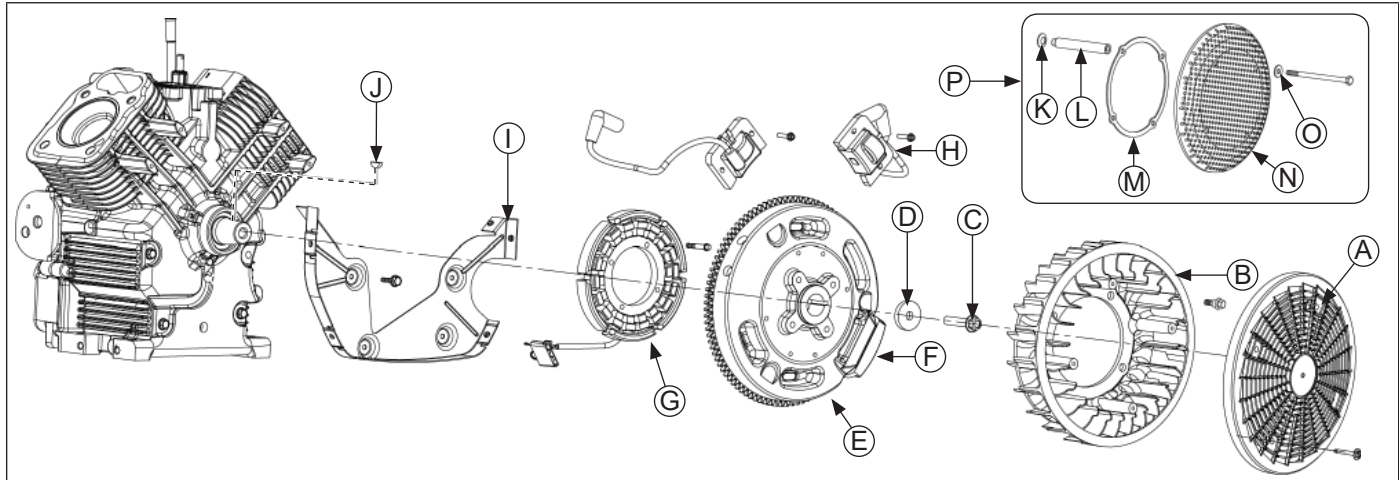

A	Debris Screen	B	Fan	C	Flywheel Screw	D	Washer
E	Flywheel	F	Magnet	G	Stator	H	Ignition Module
I	Backing Plate	J	Woodruff Key	K	Spring Washer	L	Spacer
M	Ring Support	N	Metal Debris Screen	O	Washer	P	Metal Debris Screen Assembly

Remove Ignition Modules

1. Disconnect lead from each ignition module.
2. Rotate flywheel so magnet is away from modules.
3. Remove mounting screws and ignition modules. Note position of ignition modules.

Remove Debris Screen and Fan

1. Remove socket head cap screws securing metal debris screen and remove screen.
2. Remove spacers, paying attention to curvature of spring washers between spacers and fan.
3. If there is a plastic debris screen attached to fan, remove screws securing screen. Removing screen will expose screws fastening fan to flywheel.
4. Remove screws and fan.

Remove Flywheel

NOTE: Always use a flywheel strap wrench or holding tool to hold flywheel when loosening or tightening flywheel screw. Do not use any type of bar or wedge to hold flywheel. Use of such tools could cause flywheel to become cracked or damaged.

NOTE: Always use a flywheel puller to remove flywheel from crankshaft. Do not strike crankshaft or flywheel, as these parts could become cracked or damaged. Striking puller or crankshaft can cause crank gear to move, affecting crankshaft end play.

1. Use a flywheel strap wrench or holding tool (see Tools and Aids) to hold flywheel and loosen screw securing flywheel to crankshaft.
2. Remove screw and washer.
3. Use a puller to remove flywheel from crankshaft.
4. Remove woodruff key from crankshaft.

Inspection

Inspect flywheel for cracks and flywheel keyway for damage. Replace flywheel if it is cracked. Replace flywheel, crankshaft, and key if flywheel key is sheared or keyway is damaged.

Inspect ring gear for cracks or damage. Rehlko does not provide ring gear as a serviceable part. Replace flywheel if ring gear is damaged.

Remove Stator and Backing Plates

1. Remove screws securing backing plates and stator wire bracket (if equipped). Remove backing plates and stator wire bracket.
2. Remove screws and stator.

Crankcase Components

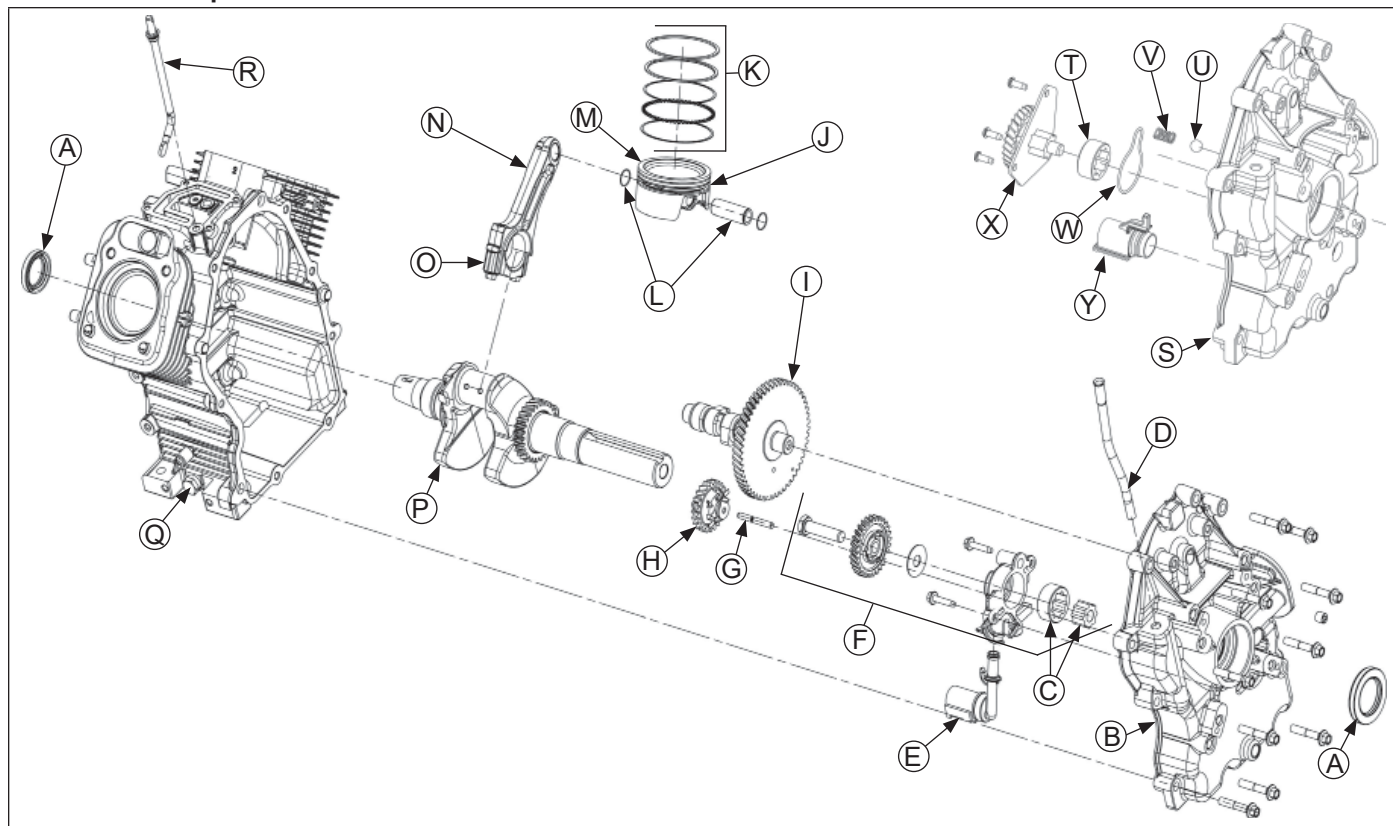

A	Oil Seal	B	Closure Plate (Style A)	C	Gerotor Gears (Style A)	D	Dipstick Tube
E	Oil Pick-Up Tube (Style A)	F	Oil Pump Assembly (Style A)	G	Governor Gear Shaft	H	Governor Gear
I	Camshaft	J	Piston Pin	K	Piston Ring Set	L	Piston Pin Retainer
M	Piston	N	Connecting Rod	O	Connecting Rod End Cap	P	Crankshaft
Q	Crankcase	R	Governor Cross Shaft	S	Closure Plate (Style B)	T	Outer Gerotor Gear (Style B)
U	Ball (Style B)	V	Spring (Style B)	W	Oil Pump Cover O-ring (Style B)	X	Oil Pump Assembly (Style B)
Y	Oil Pick-Up Tube (Style B)						

Remove Closure Plate Assembly

1. Remove screws securing closure plate to crankcase.
2. Locate splitting tabs cast into perimeter of closure plate. Insert drive end of a 1/2" breaker bar between top splitting tab and crankcase. Hold handle horizontal and pull toward you to break RTV seal. If necessary, pry at bottom tabs also. Do not pry on sealing surfaces as this could cause leaks. Carefully pull closure plate from crankcase.

Inspection

Inspect oil seal in closure plate and remove it if it is worn or damaged. Refer to Install Closure Plate Oil Seal in Reassembly for new oil seal installation.

Inspect main bearing surface for wear or damage. Refer to specifications. Replace closure plate assembly if required.

Disassembly/Inspection and Service

Governor Gear Assembly

Governor Shaft Component and Details

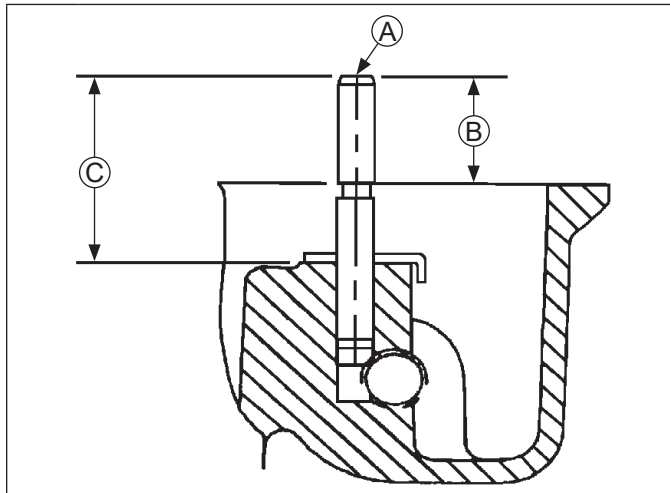

A	Gear Shaft
B	19.40 mm (0.7638 in.)
C	34.0 mm (1.3386 in.) 33.5 mm (1.3189 in.)

Governor gear assembly is located inside closure plate. If service is required, refer to Inspection, Disassembly, and Reassembly procedures.

Inspection

Inspect governor gear teeth. Replace gear if it is worn, chipped, or if any teeth are missing. Inspect governor weights. They should move freely in governor gear.

Disassembly

NOTE: Governor gear is held onto shaft by small molded tabs in gear. When gear is removed from shaft, these tabs are destroyed and gear must be replaced. Therefore, remove gear only if absolutely necessary.

Governor gear must be replaced once it is removed from closure plate.

1. Remove regulating pin and governor gear assembly.
2. Remove locking tab thrust washer located under governor gear assembly.
3. Carefully inspect governor gear shaft and replace it only if it is damaged. After removing damaged shaft, press or lightly tap replacement shaft into closure plate to depth shown.

Reassembly

1. Install locking tab thrust washer on governor gear shaft with tab down.
2. Position regulating pin within governor gear/flyweight assembly and slide both onto governor shaft.

Oil Pump Assembly (Style A)

Oil Pump (Style A) Torque Sequence

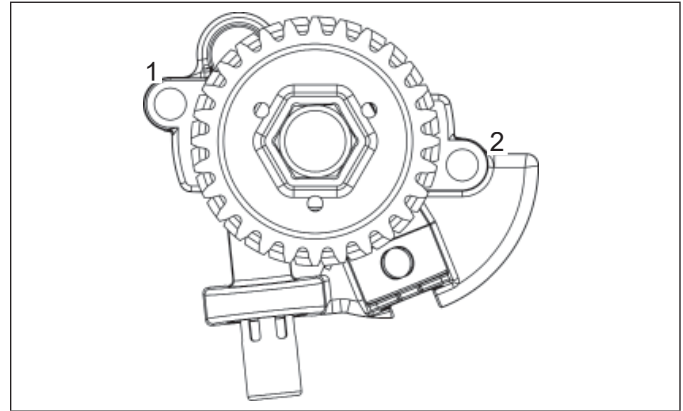

Oil pump is mounted inside closure plate. If service is required, refer to Disassembly, Inspection, and Reassembly.

Disassembly

1. Remove screws.
2. Remove oil pump assembly from closure plate.
3. Remove oil pump rotor. Unhook locking clip, and carefully pull it free from oil pump housing.

Relief valve is a one-piece style, staked to oil pump housing. Removal should not be attempted, nor is internal servicing possible. If a problem with relief valve is encountered, oil pump should be replaced.

Inspection

Inspect oil pump housing, gear, and rotors for nicks, burrs, wear, or any visible damage. If any parts are worn or damaged, replace oil pump. Check oil pickup screen for damage or restriction, replace if necessary.

Reassembly

1. Install oil pickup to oil pump body. Lubricate O-ring with oil and make sure it remains in groove as pickup is being installed.
2. Install rotor.
3. Install oil pump body to closure plate and secure with screws. Torque screws as follows:
 - a. Install fastener into screw location 1 and lightly tighten to position pump.
 - b. Install fastener into screw location 2 and fully torque to recommended value.
 - c. Torque fastener in screw location 1 to recommended value.
 - First Time Installation: 10.7 N·m (95 in. lb.)
 - All Reinstallations: 6.7 N·m (60 in. lb.)
4. After torquing, rotate gear and check for freedom of movement. Make sure there is no binding. If binding occurs, loosen screws, reposition pump, retorque screws and recheck movement.

Remove Oil Pump (Style B)

Oil pump is mounted inside closure plate. If service is required, refer to Disassembly, Inspection, and Reassembly.

Disassembly

1. Remove screws.
2. Lift oil pump assembly from closure plate. Remove outer gerotor gear from closure plate.
3. Ensure ball and spring remain installed in pressure relief hole of closure plate. If ball and spring fall out of pressure relief hole, see reassembly for correct installation.
4. Remove oil pump cover O-ring from groove in closure plate.

Inspection

Inspect oil pump housing, gear, and rotors for nicks, burrs, wear, or any visible damage. Inspect oil pump cover O-ring for cuts, nicks, or any visible damage. If any parts are worn or damaged, replace oil pump assembly and/or O-ring. Check oil pickup screen for damage or restriction, replace if necessary.

Reassembly

1. Lubricate outer gerotor gear with oil. Install outer gerotor gear through shaft of oil pump, around inner gerotor gear. Matching molding dots on inner and outer gerotor gears is not necessary and will not affect oil pump efficiency.
2. Reinstall ball, then spring into pressure relief hole in closure plate.
3. Reinstall O-ring into groove in closure plate; make sure it is fully seated in groove.
3. Install oil pump inserting center shaft into corresponding recess in closure plate. Apply consistent downward pressure to oil pump cover, compressing oil pressure relief spring and start screws. Secure oil pump by torquing screws (in no specific sequence) to 9.0 N·m (80 in. lb.).
4. After torquing, rotate gear and check for freedom of movement. Make sure there is no binding. If binding occurs, loosen screws, reposition pump, retorquing screws and recheck movement.

Remove Camshaft

Remove camshaft.

Inspection and Service

NOTE: To prevent repeat failures, camshaft and crankshaft should always be replaced as a set.

Check lobes of camshaft for wear or damage. See Specifications for minimum lift tolerance. Inspect cam gear for badly worn, chipped or missing teeth. Replacement of camshaft will be necessary if any of these conditions exist.

Remove Connecting Rods with Pistons and Rings

NOTE: If a carbon ridge is present at top of either cylinder bore, use a ridge reamer tool to remove ridge before attempting to remove piston.

NOTE: Cylinders are numbered on crankcase. Use numbers to mark each end cap, connecting rod and piston for reassembly. Do not mix end caps and connecting rods.

1. Remove screws securing closest connecting rod end cap. Remove end cap.
2. Carefully remove connecting rod and piston assembly from cylinder bore.
3. Repeat above procedures for other connecting rod and piston assembly.

Piston and Rings

Piston and Rings Components and Details

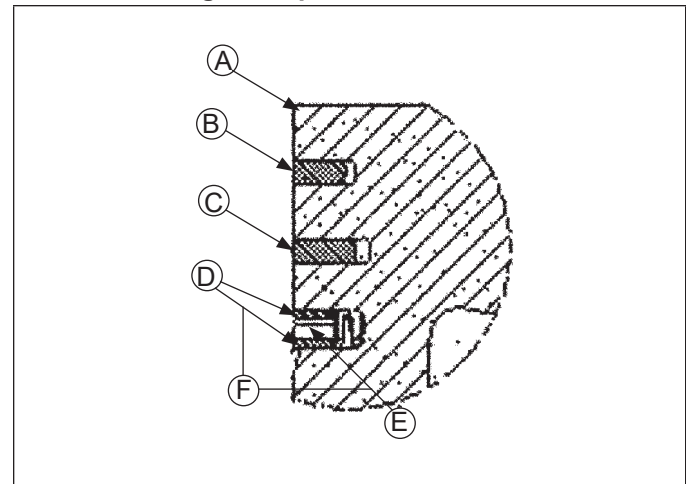

A	Piston	B	Top Compression Ring
C	Middle Compression Ring	D	Rails
E	Expander	F	Oil Control Ring (3 Piece)

Disassembly/Inspection and Service

NOTE: Rings must be installed correctly. Ring installation instructions are usually included with new ring sets. Follow instructions carefully. Use a piston ring expander to install rings. Install bottom (oil control) ring first and top compression ring last.

Scuffing and scoring of pistons and cylinder walls occurs when internal engine temperatures approach welding point of piston. Temperatures high enough to do this are created by friction, which is usually attributed to improper lubrication and/or overheating of engine.

Normally, very little wear takes place in piston boss-piston pin area. If original piston and connecting rod can be reused after new rings are installed, original pin can also be reused but new piston pin retainers are required. Piston pin is included as part of piston assembly – if pin boss in piston or pin are worn or damaged, a new piston assembly is required.

Ring failure is usually indicated by excessive oil consumption and blue exhaust smoke. When rings fail, oil is allowed to enter combustion chamber where it is burned along with fuel. High oil consumption can also occur when piston ring end gap is incorrect because ring cannot properly conform to cylinder wall under this condition. Oil control is also lost when ring gaps are not staggered during installation.

When cylinder temperatures get too high, lacquer and varnish collect on pistons causing rings to stick, which results in rapid wear. A worn ring usually takes on a shiny or bright appearance.

Scratches on rings and pistons are caused by abrasive material such as carbon, dirt, or pieces of hard metal.

Detonation damage occurs when a portion of fuel charge ignites spontaneously from heat and pressure shortly after ignition. This creates two flame fronts which meet and explode to create extreme hammering pressures on a specific area of piston. Detonation generally occurs from using low octane fuels.

Preignition or ignition of fuel charge before timed spark can cause damage similar to detonation. Preignition damage is often more severe than detonation damage. Preignition is caused by a hot spot in combustion chamber from sources such as glowing carbon deposits, blocked cooling fins, an improperly seated valve, or wrong spark plug(s).

Replacement pistons are available in STD bore size, and in 0.25 mm (0.010 in.), and 0.50 mm (0.020 in.) oversize. Replacement pistons include new piston ring sets and new piston pins.

Replacement ring sets are also available separately for STD, 0.25 mm (0.010 in.), and 0.50 mm (0.020 in.) oversize pistons. Always use new piston rings when installing pistons. Never use old rings.

Some important points to remember when servicing piston rings:

1. Cylinder bore must be deglazed before service ring sets are used.
2. If cylinder bore does not need reboring and if old piston is within wear limits and free of score or scuff marks, old piston may be reused.

3. Remove old rings and clean up grooves. Never reuse old rings.
4. Before installing new rings on piston, place top two rings, each in turn, in its running area in cylinder bore and check end gap. Compare ring gap to tolerances listed in Specifications.
5. After installing new compression (top and middle) rings on piston, check piston-to-ring side clearance. Compare clearance to tolerance listed in Specifications. If side clearance is greater than specified, a new piston must be used.

Install New Piston Rings

Piston Ring Orientation

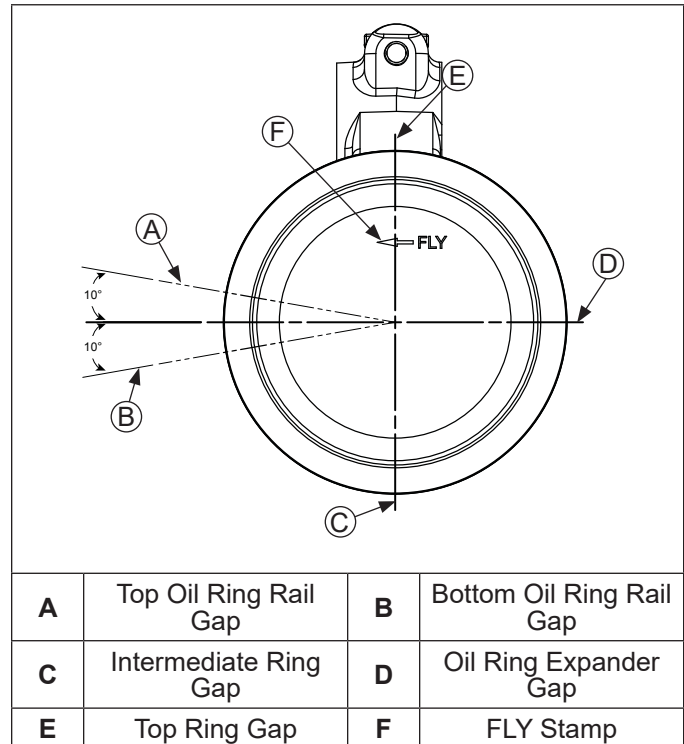

NOTE: Rings must be installed correctly. Ring installation instructions are usually included with new ring sets. Follow instructions carefully. Use a piston ring expander to install rings. Install bottom (oil control) ring first and top compression ring last.

To install new piston rings, proceed as follows:

1. Oil control ring (bottom groove): Install expander and then rails. Make sure ends of expander are not overlapped.
2. Middle compression ring (center groove): Install center ring using a piston ring installation tool. Make sure identification mark is up or colored dye stripe (if contained), is to left of end gap.
3. Top compression ring (top groove): Install top ring using a piston ring expander. Make sure identification mark is up or colored dye stripe (if contained), is to left of end gap.

Connecting Rods

Offset, stepped-cap connecting rods are used in all these engines.

Inspection and Service

Check bearing area (big end) for excessive wear, score marks, running and side clearances (refer to Specifications). Replace rod and cap if scored or excessively worn.

Service replacement connecting rods are available in STD crankpin size and 0.25 mm (0.010 in.) undersize. An 0.25 mm (0.010 in.) undersized rod can be identified by a drilled hole located in lower end of rod shank. Always refer to appropriate parts information to ensure correct replacements are used.

Remove Crankshaft

Inspection and Service

Crankshaft Components and Details

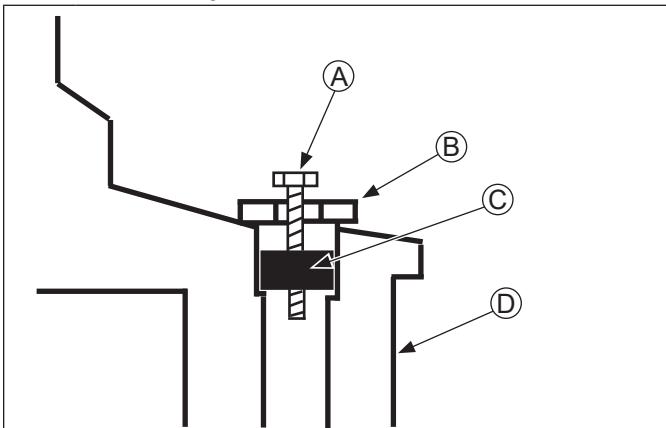

A	Self-Tapping Screw	B	Flat Washer
C	Plug	D	Crankshaft

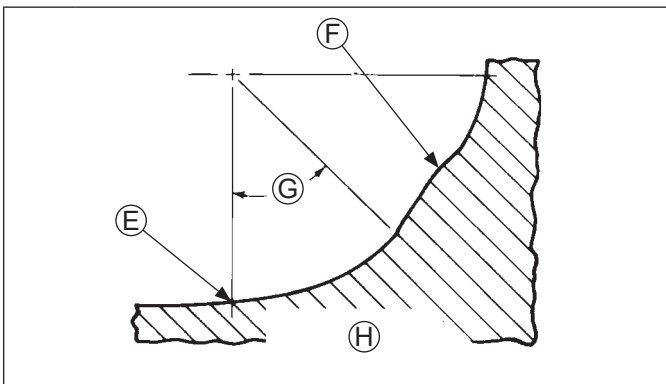

E	Fillet Must Blend Smoothly with Bearing Journal Surface
F	High Point from Fillet Intersections
G	45° Minimum
H	This Fillet Area Must Be Completely Smooth

NOTE: If crankpin is reground, visually check to ensure fillet blends smoothly with crankpin surface.

NOTE: To prevent repeat failures, camshaft and crankshaft should always be replaced as a set.

Carefully pull crankshaft from crankcase. Note thrust washers and shims if used.

Inspect gear teeth of crankshaft. If teeth are badly worn, chipped, or some are missing, replacement of crankshaft will be necessary.

Inspect crankshaft bearing surfaces for scoring, grooving, etc. Some engines have bearing inserts in crankshaft bore of closure plate and/or crankcase. Do not replace bearings unless they show signs of damage or are out of running clearance specifications. If crankshaft turns easily and noiselessly, and there is no evidence of scoring, grooving, etc., on races or bearing surfaces, bearings can be reused.

Inspect crankshaft keyways. If they are worn or chipped, replacement of crankshaft will be necessary.

Inspect crankpin for score marks or metallic pickup. Slight score marks can be cleaned with crocus cloth soaked in oil. If wear limits, as stated in Specifications and Tolerances are exceeded, it will be necessary to either replace crankshaft or reground crankpin to 0.25 mm (0.010 in.) undersize. If reground, a 0.25 mm (0.010 in.) undersize connecting rod (big end) must then be used to achieve proper running clearance. Measure crankpin for size, taper, and out-of-round.

Connecting rod journal can be ground one size under. When grinding a crankshaft, grinding stone deposits can get caught in oil passages, which could cause severe engine damage. Removing crankpin plug when crankshaft is ground provides easy access for removing any grinding deposits collected in oil passages.

Use following procedure to remove and replace plug.

Procedure to Remove Crankshaft Plug:

1. Drill a 3/16" hole through plug in crankshaft.
2. Thread a 3/4" or 1" long self-tapping screw with a flat washer into drilled hole. Flat washer must be large enough to seat against shoulder of plug bore.
3. Tighten self-tapping screw until it draws plug out of crankshaft.

Procedure to Install New Plug:

Use 1 single cylinder camshaft pin as a driver and tap plug into plug bore until it seats at bottom of bore. Make sure plug is tapped in evenly to prevent leakage.

Disassembly/Inspection and Service

Remove Governor Cross Shaft

1. Remove hitch pin and plain washer, or retainer and nylon washer from governor cross shaft.
2. Pull cross shaft with small washer out through inside of crankcase.

Governor Cross Shaft Oil Seal

Cross Shaft Oil Seal Details

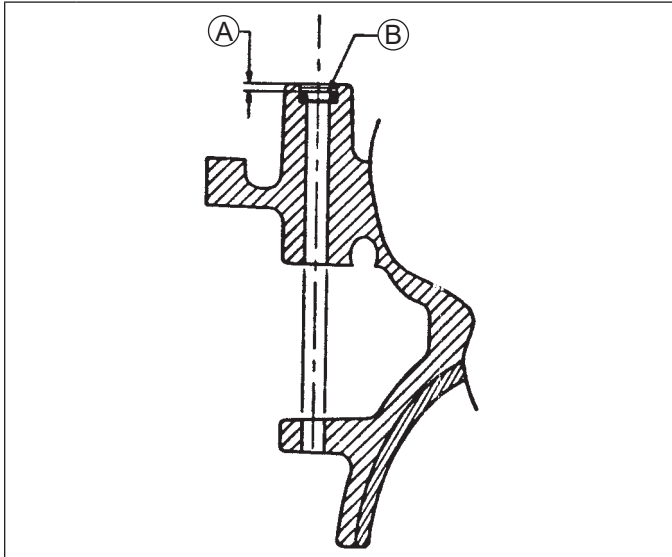

A	2.0 mm (0.0787 in.)
B	Governor Cross Shaft Seal

If governor cross shaft seal is damaged and/or leaks, replace it using following procedure.

Remove oil seal from crankcase and replace it with a new one. Install new seal to depth shown using a seal installer.

Remove Flywheel End Oil Seal

Remove oil seal from crankcase.

Crankcase

Inspection and Service

Check all gasket surfaces to make sure they are free of gasket fragments. Gasket surfaces must also be free of deep scratches or nicks.

Inspect main bearing (if equipped) for wear or damage. Replace crankcase using a miniblock or short block as required.

Check cylinder bore wall for scoring. In severe cases, unburned fuel can cause scuffing and scoring of cylinder wall. It washes necessary lubricating oils off piston and cylinder wall. As raw fuel seeps down cylinder wall, piston rings make metal to metal contact with wall. Scoring of cylinder wall can also be caused by localized hot spots resulting from blocked cooling fins or from inadequate or contaminated lubrication.

If cylinder bore is badly scored, excessively worn, tapered, or out-of-round, resizing is necessary. Use an inside micrometer to determine amount of wear (refer to Specifications), then select nearest suitable oversize of either 0.25 mm (0.010 in.) or 0.50 mm (0.020 in.). Resizing to one of these oversizes will allow usage of available oversize piston and ring assemblies. First, resize using a boring bar, then follow these procedures for honing cylinder.

Honing

Detail

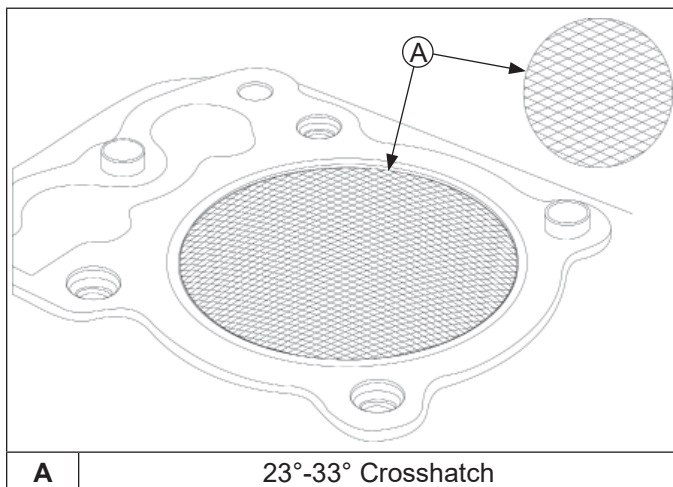

NOTE: Rehlko pistons are custom-machined to exacting tolerances. When oversizing a cylinder, it should be machined exactly 0.25 mm (0.010 in.) or 0.50 mm (0.020 in.) over new diameter (refer to Specifications). A corresponding oversize Rehlko replacement piston will then fit correctly.

While most commercially available cylinder hones can be used with either portable drills or drill presses, use of a low speed drill press is preferred as it facilitates more accurate alignment of bore in relation to crankshaft crossbore. Honing is best accomplished at a drill speed of about 250 RPM and 60 strokes per minute. After installing coarse stones in hone, proceed as follows:

1. Lower hone into bore and after centering, adjust so stones are in contact with cylinder wall. Use of a commercial cutting-cooling agent is recommended.
2. With lower edge of each stone positioned even with lowest edge of bore, start drill and honing process. Move hone up and down while resizing to prevent formation of cutting ridges. Check size frequently.
3. When bore is within 0.064 mm (0.0025 in.) of desired size, remove coarse stones and replace them with burnishing stones. Continue with burnishing stones until bore is within 0.013 mm (0.0005 in.) of desired size and then use finish stones (220-280 grit) and polish bore to its final size. A crosshatch should be observed if honing is done correctly. Crosshatch should intersect at approximately 23°-33° off horizontal. Too flat an angle could cause rings to skip and wear excessively, and too steep an angle will result in high oil consumption.
4. After resizing, check bore for roundness, taper, and size. Use an inside micrometer, telescoping gauge, or bore gauge to take measurements. These measurements should be taken at 3 locations in cylinder—at top, middle, and bottom. There are 2 measurements that should be taken (perpendicular to each other) at all 3 locations.

Clean Cylinder Bore After Honing

Proper cleaning of cylinder walls following boring and/or honing is very critical to a successful overhaul. Machining grit left in cylinder bore can destroy an engine in less than one hour of operation after a rebuild.

Final cleaning operation should always be a thorough scrubbing with a brush and hot, soapy water. Use a strong detergent capable of breaking down machining oil while maintaining a good level of suds. If suds break down during cleaning, discard dirty water and start again with more hot water and detergent. Following scrubbing, rinse cylinder with very hot, clear water, dry it completely, and apply a light coating of engine oil to prevent rusting.

Measuring Piston-to-Bore Clearance

Piston Detail

Model	Dimension A
CH682	13 mm (0.5118 in.)
CH732	6 mm (0.2362 in.)
CH742	
CH752	

NOTE: Do not use a feeler gauge to measure piston-to-bore clearance—it will yield inaccurate measurements. Always use a micrometer.

Before installing piston into cylinder bore, it is necessary clearance be accurately checked. This step is often overlooked, and if clearances are not within specifications, engine failure will usually result.

Use following procedure to accurately measure piston-to-bore clearance:

1. Use a micrometer and measure diameter of piston above bottom of piston skirt and perpendicular to piston pin.
2. Use an inside micrometer, telescoping gauge, or bore gauge and measure cylinder bore. Take measurement approximately 63.5 mm (2.5 in.) below top of bore and perpendicular to piston pin.
3. Piston-to-bore clearance is difference between bore diameter and piston diameter (step 2 minus step 1).

Reassembly

Crankcase Components

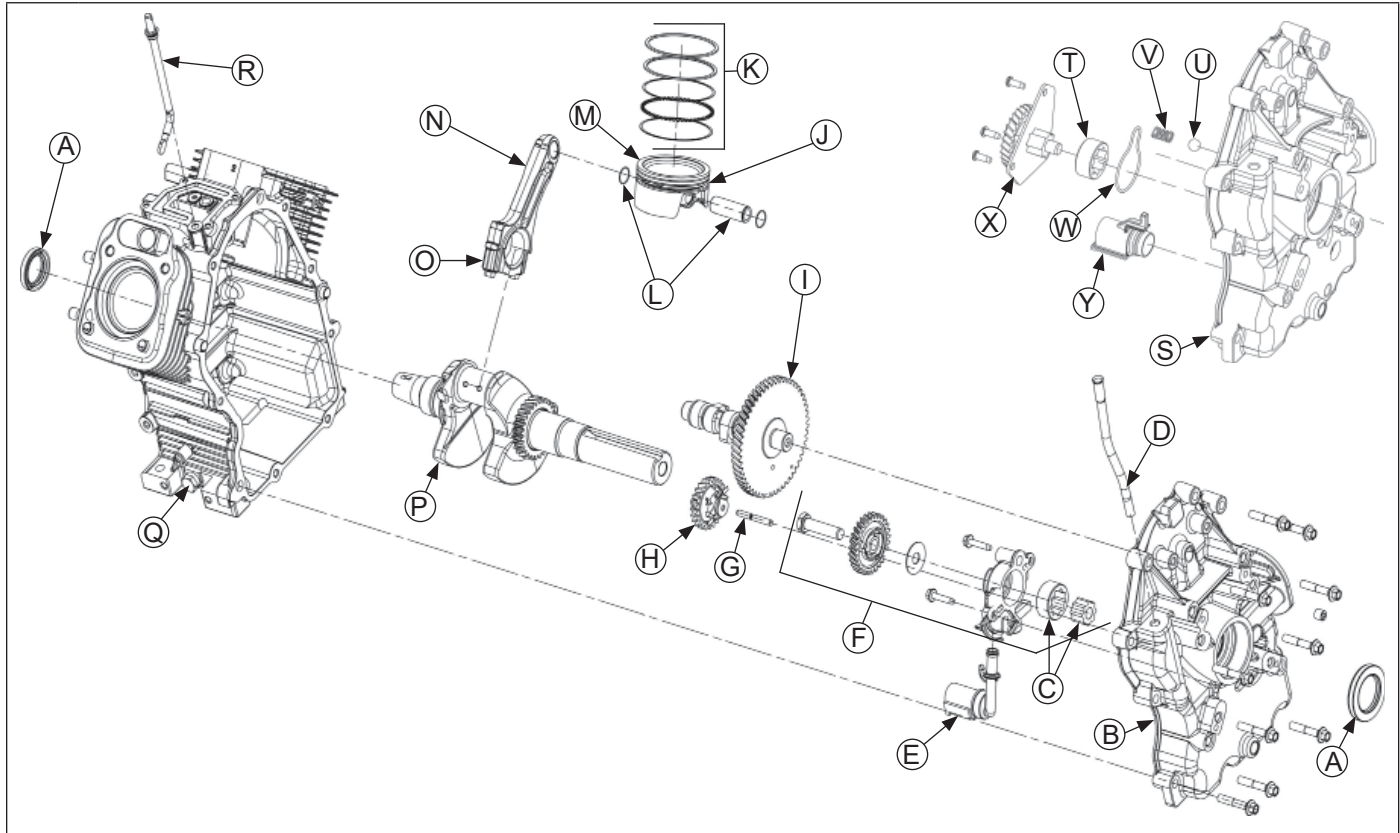

A	Oil Seal	B	Closure Plate (Style A)	C	Gerotor Gears (Style A)	D	Dipstick Tube
E	Oil Pick-Up Tube (Style A)	F	Oil Pump Assembly (Style A)	G	Governor Gear Shaft	H	Governor Gear
I	Camshaft	J	Piston Pin	K	Piston Ring Set	L	Piston Pin Retainer
M	Piston	N	Connecting Rod	O	Connecting Rod End Cap	P	Crankshaft
Q	Crankcase	R	Governor Cross Shaft	S	Closure Plate (Style B)	T	Outer Gerotor Gear (Style B)
U	Ball (Style B)	V	Spring (Style B)	W	Oil Pump Cover O-ring (Style B)	X	Oil Pump Assembly (Style B)
Y	Oil Pick-Up Tube (Style B)						

NOTE: Make sure engine is assembled using all specified torque values, tightening sequences and clearances. Failure to observe specifications could cause severe engine wear or damage. Always use new gaskets. Apply a small amount of oil to threads of critical fasteners before assembly, unless a sealant or Loctite® is specified or preapplied.

Make sure all traces of any cleaner are removed before engine is assembled and placed into operation. Even small amounts of these cleaners can quickly break down lubricating properties of engine oil.

Check closure plate, crankcase, cylinder heads, and valve covers to be certain all old sealing material has been removed. Use gasket remover, lacquer thinner, or paint remover to remove any remaining traces. Clean surfaces with isopropyl alcohol, acetone, lacquer thinner, or electrical contact cleaner.

Install Flywheel End Oil Seal

1. Make sure seal bore of crankcase is clean and free of any nicks or burrs.
2. Apply a light coat of clean engine oil to outside diameter of oil seal.
3. Drive oil seal into crankcase using a seal driver. Make sure oil seal is installed straight and true in bore and tool bottoms against crankcase.

Install Governor Cross Shaft

1. Lubricate governor cross shaft bearing surfaces in crankcase with engine oil.
2. Slide small lower washer onto governor cross shaft and install cross shaft from inside of crankcase.
3. Install nylon washer onto governor cross shaft, then start push-on retaining ring. Hold cross shaft up in position, place a 0.50 mm (0.020 in.) feeler gauge on top of nylon washer, and push retaining ring down shaft to secure. Remove feeler gauge, which will have established proper end play.

Install Crankshaft

Carefully slide flywheel end of crankshaft through main bearing in crankcase.

Install Connecting Rods with Pistons and Rings

Piston and Connecting Rod Details

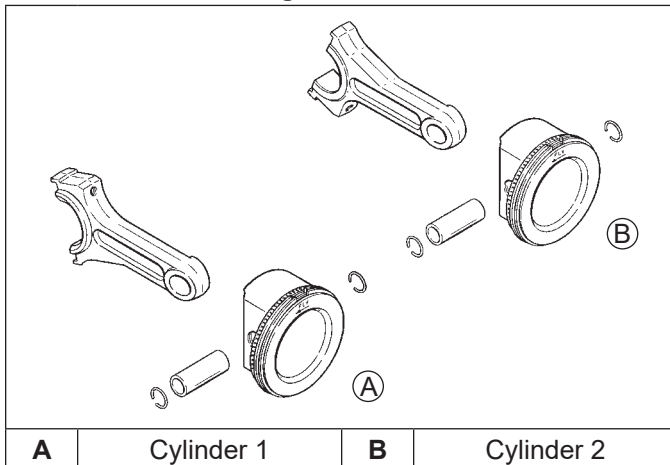

NOTE: Cylinders are numbered on crankcase. Make sure to install piston, connecting rod and end cap into its appropriate cylinder bore as previously marked at disassembly. Do not mix end caps and connecting rods.

NOTE: Proper orientation of piston/connecting rod assemblies inside engine is extremely important. Improper orientation can cause extensive wear or damage. Be certain pistons and connecting rods are assembled exactly as shown.

NOTE: Align chamfer of connecting rod with chamfer of its mating end cap. When installed, flat faces of connecting rods should face each other. Faces with raised rib should be toward outside.

1. If piston rings were removed, see Disassembly/Inspection and Service procedure to install new rings.
2. Lubricate cylinder bore, piston, and piston rings with engine oil. Compress rings of piston 1 using a piston ring compressor.
3. Lubricate crankshaft journals and connecting rod bearing surfaces with engine oil.

4. Make sure FLY stamping on piston is facing towards flywheel side of engine. Use a hammer with a rubber grip and gently tap piston into cylinder as shown. Be careful oil ring rails do not spring free between bottom of ring compressor and top of cylinder.
5. Install inner rod cap to connecting rod using screws. Torque in increments to 13.6 N·m (120 in. lb.). Illustrated instructions are provided in service rod package.
6. Repeat above procedure for other connecting rod and piston assembly.

Install Camshaft

1. Liberally apply camshaft lubricant to each cam lobe. Lubricate camshaft bearing surfaces of crankcase and camshaft with engine oil.
2. Position timing mark of crankshaft gear at 12 o'clock position.
3. Turn governor cross shaft clockwise until lower end of shaft contacts cylinder. Make sure cross shaft remains in this position while installing camshaft.
4. Slide camshaft into bearing surface of crankcase, positioning timing mark of camshaft gear at 6 o'clock position. Make sure camshaft gear and crankshaft gear mesh, with both timing marks aligned.

Oil Pump Assembly

Oil pump is mounted inside closure plate. If service was required, and oil pump was removed, refer to Disassembly/Inspection and Service.

Governor Gear Assembly

Governor gear assembly is located inside closure plate. If service was required, and governor was removed, refer to Disassembly/Inspection and Service.

Reassembly

Thrust Bearing, Washer and Shim

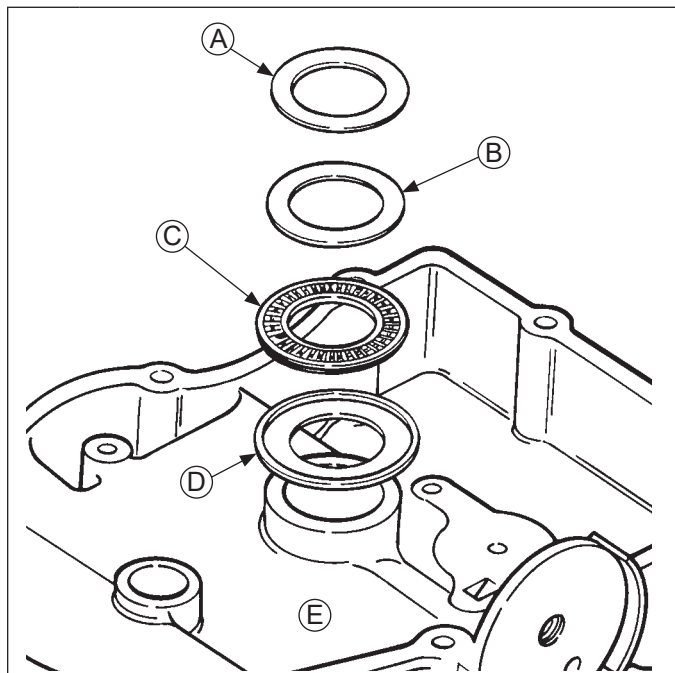

A	Thrust Shim	B	Thrust Washer
C	Needle Thrust Bearing	D	Bearing Race
E	Closure Plate		

Some specifications use a needle type thrust bearing, thrust washer and shim spacer to control end play of crankshaft. If these items are noted during disassembly, make sure they are reinstalled in sequence shown. A different procedure will have to be followed to check and adjust crankshaft end play on these models.

Race for thrust bearing presses loosely into closure plate. If it is not already installed, push it into crankshaft bore inside closure plate. Pack thrust bearing with heavy grease and stick bearing into race. Wipe some grease on face of thrust washer and stick it onto thrust bearing. Wipe some grease on face of original shim spacer and stick it onto thrust washer.

Install closure plate onto crankcase without applying RTV sealant and secure it with only 2 or 3 fasteners at this time. Use a dial indicator to check crankshaft end play. End play should be 0.070/1.190 mm (0.0028/0.0468 in.). Shim spacers are available in 3 color coded thicknesses if adjustment is needed.

Clearance Specifications-Crankshaft End Play Shims

Green	0.8366-0.9127 mm (0.8750 mm/0.034 in. Nominal)
Yellow	1.0652-1.1414 mm (1.1033 mm/0.043 in. Nominal)
Red	1.2938-1.3700 mm (1.3319 mm/0.052 in. Nominal)

Remove closure plate. If end play requires adjustment, remove original spacer and install appropriate size shim spacer in its place. Then follow procedure under Install Closure Plate Assembly.

Install Closure Plate Oil Seal

Oil Seal Depth

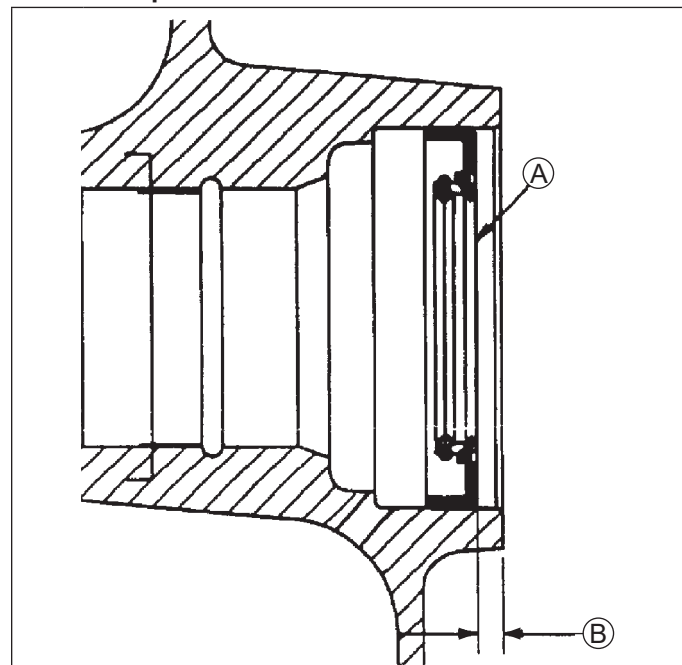

A	Oil Seal	B	Seal Depth 8.0 mm (0.314 in.)
----------	----------	----------	----------------------------------

1. Check to make sure there are no nicks or burrs in crankshaft bore of closure plate.
2. Apply a light coat of engine oil to outside diameter of oil seal.
3. Drive oil seal into closure plate using a seal driver. Make sure oil seal is installed straight and true in bore to depth shown.

Install Closure Plate Assembly

Sealant Pattern and Torque Sequence

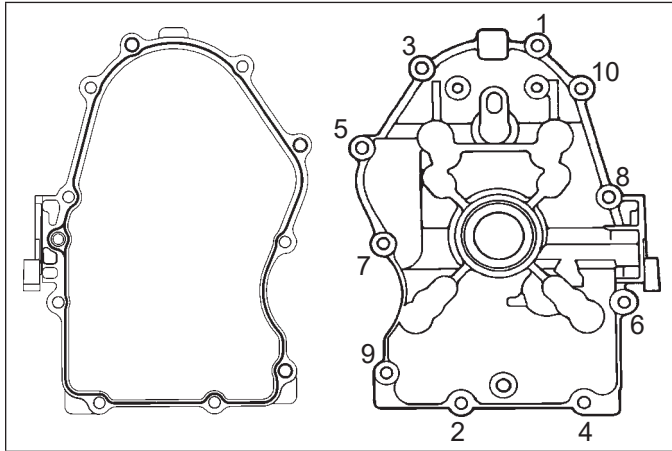

RTV sealant is used as a gasket between closure plate and crankcase. Always use fresh sealant. Using outdated sealant can result in leakage.

1. Be sure sealing surfaces have been cleaned and prepared. Install a new O-ring in closure plate.
2. Check to make sure there are no nicks or burrs on sealing surfaces of closure plate or crankcase.
3. Apply a 1.5 mm (1/16 in.) bead of sealant to sealing surface of closure plate.
4. Make sure end of governor cross shaft is lying against bottom of cylinder 1 inside crankcase.
5. Install closure plate to crankcase. Carefully seat camshaft and crankshaft into their mating bearings. Rotate crankshaft slightly to help engage oil pump and governor gear meshes.
6. Install screws securing closure plate to crankcase. Torque fasteners to 24.4 N·m (216 in. lb.) following sequence. On some engines one mounting screw is plated. Plated screw is typically installed in hole location 6.

Flywheel/Ignition Components

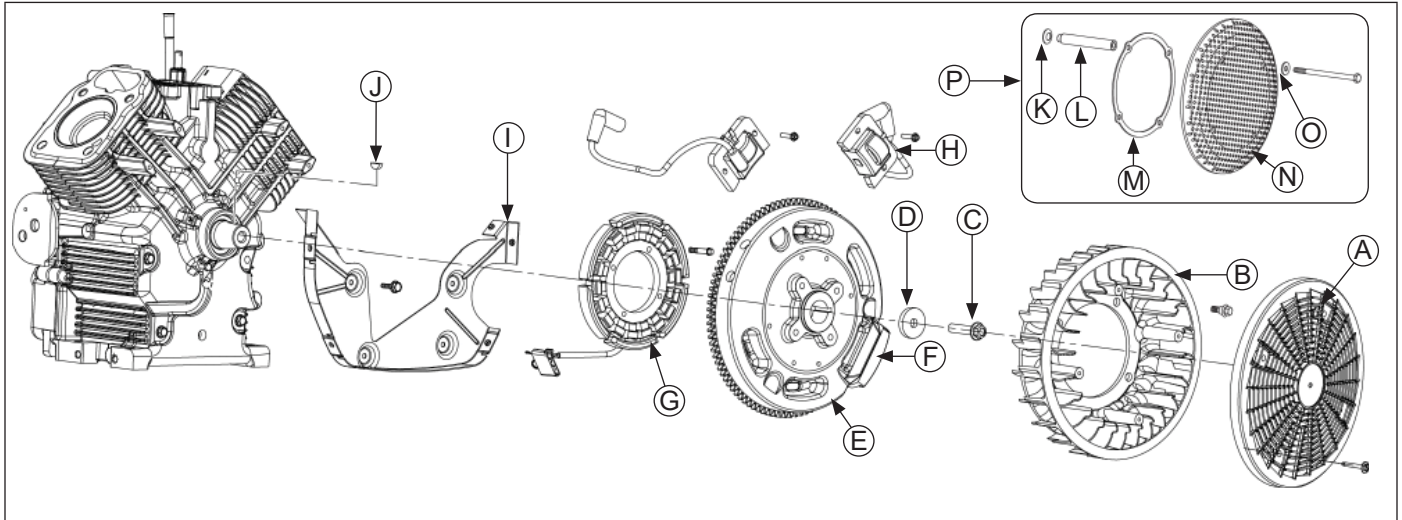

A	Debris Screen	B	Fan	C	Flywheel Screw	D	Washer
E	Flywheel	F	Magnet	G	Stator	H	Ignition Module
I	Backing Plate	J	Woodruff Key	K	Spring Washer	L	Spacer
M	Ring Support	N	Metal Debris Screen	O	Washer	P	Metal Debris Screen Assembly

Install Stator and Backing Plates

1. Apply pipe sealant with Teflon® (Loctite® 592™ Thread Sealant or equivalent) to stator mounting holes.
2. Position stator aligning mounting holes so leads are at bottom, towards crankcase.
3. Install and torque screws to 6.2 N·m (55 in. lb.).
4. Route stator leads in crankcase channel, then install backing plates and stator wire bracket (if used). Secure using screws. Torque screws to 7.3 N·m (65 in. lb.).

Reassembly

Install Flywheel

	⚠ CAUTION
	Damaging Crankshaft and Flywheel can cause personal injury.
Using improper procedures can lead to broken fragments. Broken fragments could be thrown from engine. Always observe and use precautions and procedures when installing flywheel.	

NOTE: Before installing flywheel make sure crankshaft taper and flywheel hub are clean, dry, and completely free of any lubricants. Presence of lubricants can cause flywheel to be overstressed and damaged when screw is torqued to specifications.

NOTE: Make sure flywheel key is installed properly in keyway. Flywheel can become cracked or damaged if key is not properly installed.

1. Install woodruff key into keyway of crankshaft. Make sure key is properly seated and parallel with shaft taper.
2. Install flywheel onto crankshaft being careful not to shift woodruff key.
3. Install screw and washer.
4. Use a flywheel strap wrench or holding tool to hold flywheel. Torque screw securing flywheel to crankshaft to 66.4 N·m (49 ft. lb.).

Install Flywheel Fan

NOTE: Position ears located at rear perimeter of fan in recesses of flywheel.

1. Install fan onto flywheel using four screws.
2. Torque screws to 9.9 N·m (88 in. lb.).

Install Plastic Debris Screen

	⚠ CAUTION
	Failure to utilize or reassemble debris screen as designed could result in debris screen failure and serious personal injury.

If engine has a plastic debris screen, place plastic screen on fan and secure with screws. Torque screws to 4.0 N·m (35 in. lb.).

Install Supports for Metal Debris Screen

1. If a metal debris screen is used, with threaded individual supports, install a spacer washer on external threads. Apply Loctite® 242® (removable) onto threads. Install four supports as shown.
2. Tighten supports with a torque wrench to 9.9 N·m (88 in. lb.). Debris screen will be installed to supports after blower housing is in place.

Cylinder Head Components

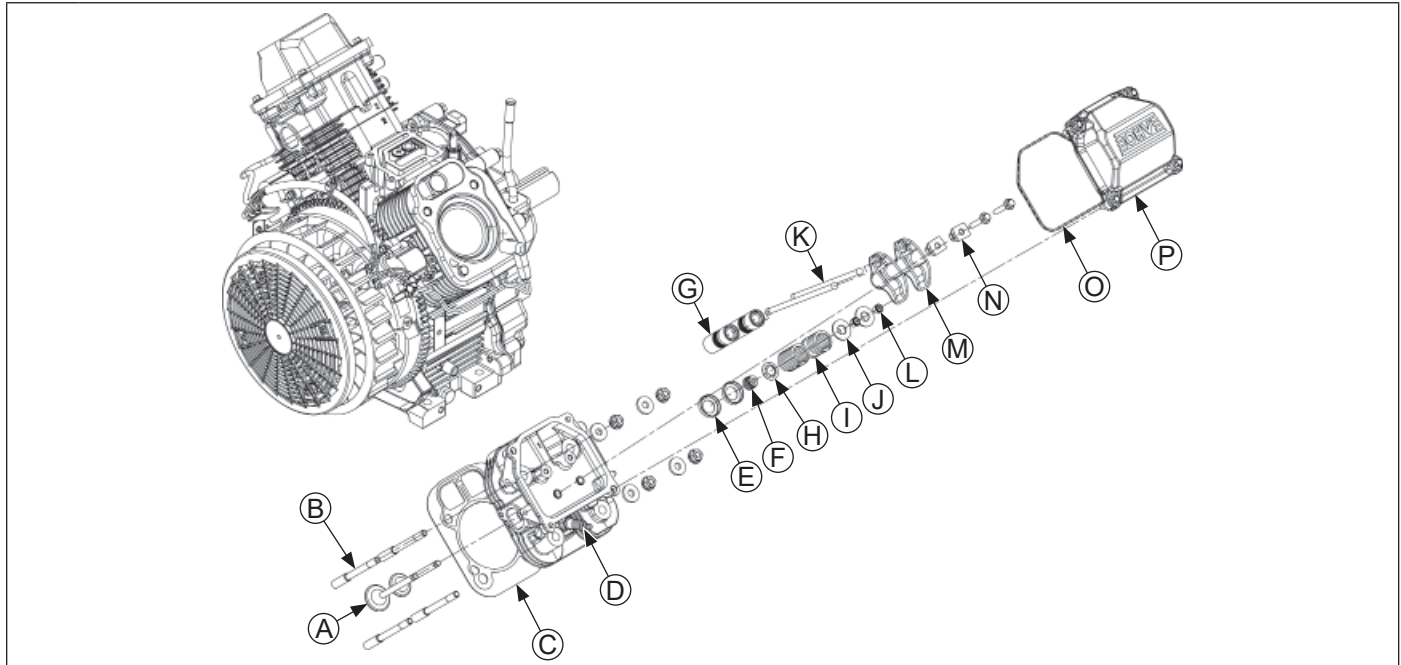

A	Valve	B	Stud	C	Gasket	D	Spark Plug
E	Cap	F	Valve Stem Seal	G	Hydraulic Lifter	H	Retainer
I	Valve Spring	J	Valve Spring Retainer	K	Push Rod	L	Valve Keeper
M	Rocker Arm	N	Rocker Arm Pivot	O	Valve Cover O-ring	P	Valve Cover

Install Hydraulic Lifters

NOTE: Hydraulic lifters should always be installed in same position as before disassembly. Exhaust lifters are located on output shaft side of engine while intake lifters are located on fan side of engine. Cylinder numbers are embossed on top of crankcase and each cylinder head.

1. Refer to Disassembly/Inspection and Service for lifter preparation (bleed down) procedures.
2. Apply camshaft lubricant to bottom surface of each lifter. Lubricate hydraulic lifters and lifter bores in crankcase with engine oil.
3. Note mark or tag identifying hydraulic lifters as either intake or exhaust and cylinder 1 or cylinder 2. Install hydraulic lifters into their appropriate location in crankcase. Do not use a magnet.

Valve Stem Seals

These engines use valve stem seals on intake valves and occasionally on exhaust valves. Always use a new seal whenever valve is removed or if seal is deteriorated or damaged in any way. Never reuse an old seal.

Assemble Cylinder Heads

Prior to installation, lubricate all components with engine oil, paying particular attention to lip of valve stem seal, valve stems and valve guides. Install in order listed below using a valve spring compressor.

- Intake and exhaust valves.
- Valve spring caps.
- Valve springs.
- Valve spring retainers.
- Valve spring keepers.

Reassembly

Install Cylinder Heads

Cylinder Head Torque Sequence

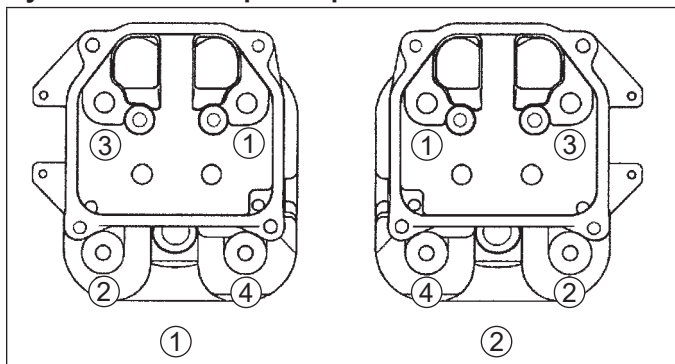

NOTE: Cylinder heads must be attached with original type of mounting hardware, using either screws, or mounting studs with nuts and washers. Heads are machined differently for studs than for screws, so fastening method cannot be altered unless heads are being replaced. Do not intermix components.

Heads secured with screws:

NOTE: Match numbers embossed on cylinder heads and crankcase.

1. Check to make sure there are no nicks or burrs on sealing surfaces of cylinder head or crankcase.
2. Install a new cylinder head gasket, (with printing up).
3. Install cylinder head and start four screws.
4. Torque screws in two stages; first to 22.6 N·m (200 in. lb.), finally to 41.8 N·m (370 in. lb.), following sequence shown.

Heads secured with mounting studs, nuts, and washers:

1. Check to make sure there are no nicks or burrs on sealing surfaces of cylinder head or crankcase.
2. If all studs were left intact, go to Step 5. If any studs were disturbed or removed, install new studs as described in Step 3. Do not use/reinstall any loosened or removed studs.
3. Install new mounting stud(s) into crankcase.
 - a. Thread and lock two mounting nuts together on smaller diameter threads.
 - b. Thread opposite end of stud with preapplied locking compound into crankcase until specified height from crankcase surface is achieved. When threading in studs, use a steady tightening motion without interruption until proper height is obtained. Otherwise, frictional heat from engaging threads may cause locking compound to set up prematurely.

Studs closest to lifters must have an exposed height of 75 mm (2 15/16 in.).

Studs furthest from lifters must have an exposed height of 69 mm (2 3/4 in.).
 - c. Remove nuts and repeat procedure as required.

4. Install cylinder head. Match numbers on cylinder heads and crankcase. Make sure head is flat on gasket and dowel pins.
5. Lightly lubricate exposed (upper) threads of studs with engine oil. Install a new flat washer and nut onto each mounting stud. Torque nuts in two stages; first to 16.9 N·m (150 in. lb.), finally to 35.5 N·m (315 in. lb.), following sequence shown.

Install Push Rods and Rocker Arms

NOTE: Push rods should always be installed in same position as before disassembly.

NOTE: Two different screws have been used to secure rocker arms/pivots. Black screws are used with heads that have a rocker pivot hole depth of approximately 21 mm (0.83 in.). Silver screws are used with heads that have a rocker pivot hole depth of approximately 35 mm (1.38 in.).

1. Note mark or tag identifying push rod as either intake or exhaust and cylinder 1 or 2. Dip ends of push rods in engine oil and install, making sure each push rod ball seats in its hydraulic lifter socket.
2. Apply grease to contact surfaces of rocker arms and rocker arm pivots. Install rocker arms and rocker arm pivots on one cylinder head, and start two screws.
3. Torque black screws to 18.1 N·m (160 in. lb.). Torque silver screws to 13.6 N·m (120 in. lb.). Repeat for other rocker arm.
4. Use a spanner wrench or rocker arm lifting tool to lift rocker arms and position push rods underneath.
5. Repeat above steps for remaining cylinder. Do not interchange parts from cylinder heads.
6. Rotate crankshaft to check for free operation of valve train. Check clearance between valve spring coils at full lift. Minimum allowable clearance is 0.25 mm (0.010 in.).

Check Assembly

Rotate crankshaft a minimum of two revolutions to check longblock assembly and overall proper operation.

Install Spark Plugs

1. Check gap using wire feeler gauge. Adjust gap to 0.76 mm (0.030 in.).
2. Install plug into cylinder head.
3. Torque plug to 27 N·m (20 ft. lb.).

Install Ignition Modules

1. Rotate flywheel to position magnet away from ignition module bosses.
2. CDI modules are installed on cylinder 1 with single kill tab away from cylinder/towards you, and on cylinder 2 with single kill tab towards cylinder/away from you.
MDI modules are installed with flat side out/towards you.
3. Install each ignition module to crankcase bosses. Slide modules up as far away from flywheel as possible and snug screws to hold them in position.
4. Rotate flywheel to position magnet directly under one ignition module.
5. Insert a 0.25 mm (0.009 in.) flat feeler gauge between magnet and ignition module. Loosen screws enough to allow magnet to pull module down against feeler gauge.
6. Torque screws to 4.0-6.2 N·m (35-55 in. lb.).
7. Repeat steps 4 through 6 for other ignition module.
8. Rotate flywheel back and forth checking for clearance between magnet and ignition modules. Make sure magnet does not strike modules. Check gap with a feeler gauge and readjust if necessary.
Final air gap is: 0.203/0.305 mm (0.008/0.012 in.).

Install Intake Manifold

Torque Sequence

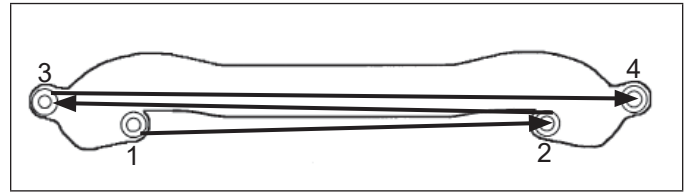

1. Install intake manifold and new gaskets, with wiring harness attached, to cylinder heads. Slide any wiring harness clips onto appropriate bolts before installing. Make sure gaskets are in proper orientation. Torque screws in two stages, first to 7.4 N·m (66 in. lb.), then to 9.9 N·m (88 in. lb.), using sequence shown.
2. Route wiring harness through mounting clip on underside of debris shield if separated earlier. Carefully position debris shield as rearward as possible.
3. Connect each kill lead to tab terminal on each ignition module.

Reassembly

External Engine Components

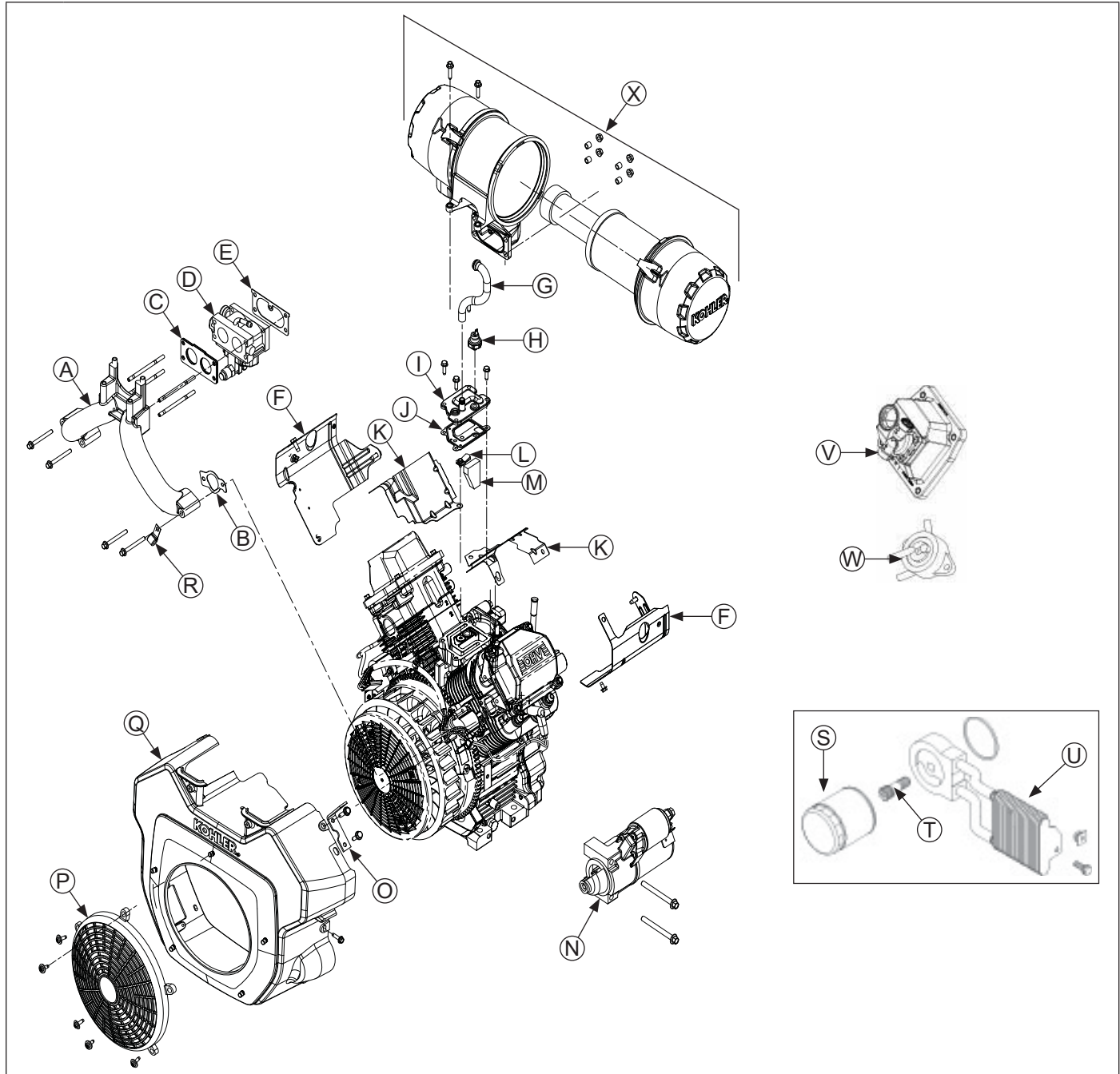

A	Intake Manifold	B	Intake Manifold Gasket	C	Carburetor Gasket	D	Carburetor
E	Air Cleaner Gasket	F	Outer Baffle	G	Breather Tube	H	Oil Sentry™
I	Breather Cover	J	Breather Gasket	K	Inner Baffle	L	Breather Reed
M	Filter	N	Electric Starter	O	Lifting Bracket	P	Fixed Guard
Q	Blower Housing	R	Wire Clip	S	Oil Filter	T	Nipple
U	Oil Cooler	V	Valve Cover Fuel Pump	W	Pulse Fuel Pump	X	Air Cleaner

Install Breather Cover and Inner Baffles

Breather Cover Torque Sequence

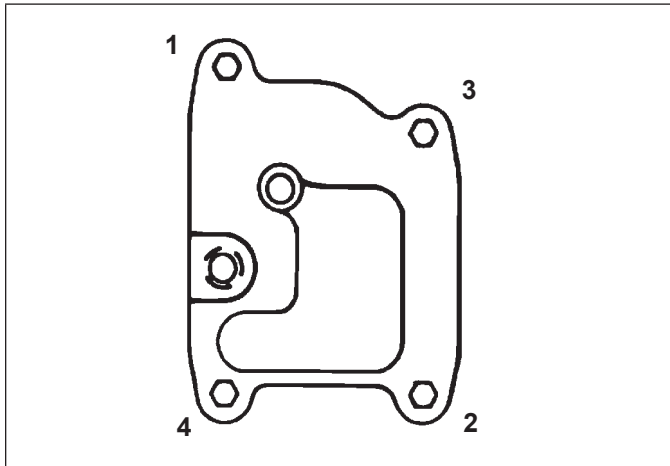

1. Be sure sealing surfaces of crankcase and breather cover are clean of old gasket material. Do not scrape surfaces as this could result in leakage.
2. Check to make sure there are no nicks or burrs on sealing surfaces.
3. Install breather reed and breather reed retainer onto crankcase and secure with screw. Hold assembly in line when tightening. Torque screw to 3.9 N·m (35 in. lb.).
4. Insert breather filter into position in crankcase. Make sure no filter strands are on sealing surface.
5. Install new breather gasket.
6. Carefully position breather cover on crankcase. Install first two screws at positions shown and finger tighten at this time.
7. Install inner baffles using two remaining screws and finger tighten. Do not torque screws at this time; they will be tightened after blower housing and outer baffles are installed.

Install Blower Housing and Outer Baffles

NOTE: Do not completely tighten screws until all items are installed to allow shifting for hole alignment.

1. Connect plug to key switch in blower housing (if equipped).
2. Slide blower housing into position over front edge of inner baffles. Start a few screws to hold it in place. Lift debris shield up above mounting surface, as blower housing is installed. Make sure ground lead, fuel solenoid lead, and oil pressure switch leads are accessible and in proper position.
3. Position outer baffles and loosely start mounting screws. M6 screws go into back of cylinders. Short M5 screws go into lower holes closest to blower housing. Short screw on oil filter side is also used to mount wire harness clip. Be sure any wire harnesses or leads are routed out through proper offsets or notches, so they will not be pinched between blower housing and baffles.

4. If rectifier-regulator was not removed, attach ground wire or metal grounding bracket for rectifier-regulator, using silver colored screw and washer, to lower blower housing hole.
5. Tighten all shrouding fasteners. Torque blower housing screws to 6.2 N·m (55 in. lb.) in a new hole, or to 4.0 N·m (35 in. lb.) in a used hole. Torque shorter M5 side baffle screws to 4.0 N·m (35 in. lb.). Torque upper M5 side baffle screws (into cylinder head) to 6.2 N·m (55 in. lb.) in a new hole, or to 4.0 N·m (35 in. lb.) in a used hole. Torque two rear M6 baffle mounting screws to 10.7 N·m (95 in. lb.) in a new hole, or to 7.3 N·m (65 in. lb.) in a used hole.
6. If an overlapping style flywheel screen is used, attach it to supports or flywheel. For a metal flywheel screen, apply Loctite® 242® to screw threads (M6) and torque to 9.9 N·m (88 in. lb.). Torque plastic screen mounting screws (M4) to 2.2 N·m (20 in. lb.).
7. Torque breather cover screws to 11.3 N·m (100 in. lb.) into new holes or 7.3 N·m (65 in. lb.) into used holes in sequence shown. Note first screw is torqued a second time.

Reconnect Rectifier-Regulator

1. Install rectifier-regulator in blower housing, if removed previously, then connect rectifier-regulator ground lead with washer and silver screw through eyelet as shown. If a grounding bracket is used, secure with lower mounting screw and washer, against outer side of rectifier-regulator.
2. Install B+ terminal/lead into center position of rectifier-regulator plug and connect plug to rectifier-regulator.

Install Electric Starter Motor

NOTE: If engine uses a side mount muffler on starter side, be sure to tie wires close to starter to avoid contact with hot exhaust parts.

1. Install starter motor using two screws.
2. Torque screws to 15.3 N·m (135 in. lb.).
3. Connect leads to solenoid.

Reassembly

Install Fuel Pump

	⚠ WARNING
	<p>Explosive Fuel can cause fires and severe burns.</p> <p>Do not fill fuel tank while engine is hot or running.</p>
<p>Gasoline is extremely flammable and its vapors can explode if ignited. Store gasoline only in approved containers, in well ventilated, unoccupied buildings, away from sparks or flames. Spilled fuel could ignite if it comes in contact with hot parts or sparks from ignition. Never use gasoline as a cleaning agent.</p>	

NOTE: If a new fuel pump is being installed, make sure orientation of new pump is consistent with removed pump. Internal damage may occur if installed incorrectly.

1. Install pulse style fuel pump and lines as an assembly. Connect pulse line to crankcase vacuum fitting.
2. Install fuel pump using screws. Torque screws to 2.3 N·m (20 in. lb.).

Install Carburetor

	⚠ WARNING
	<p>Explosive Fuel can cause fires and severe burns.</p> <p>Do not fill fuel tank while engine is hot or running.</p>
<p>Gasoline is extremely flammable and its vapors can explode if ignited. Store gasoline only in approved containers, in well ventilated, unoccupied buildings, away from sparks or flames. Spilled fuel could ignite if it comes in contact with hot parts or sparks from ignition. Never use gasoline as a cleaning agent.</p>	

1. Use a new carburetor gasket. Make sure all holes align and are open.
2. Apply Loctite® 242® to shorter (inner) set of threads of any removed studs.
3. Assemble carburetor gasket and carburetor to intake manifold, and start any removed studs. Use two flange nuts locked flange to flange and tighten each stud until bottomed/tight.
4. Connect ground lead and fuel solenoid lead as equipped.

Control Bracket Components

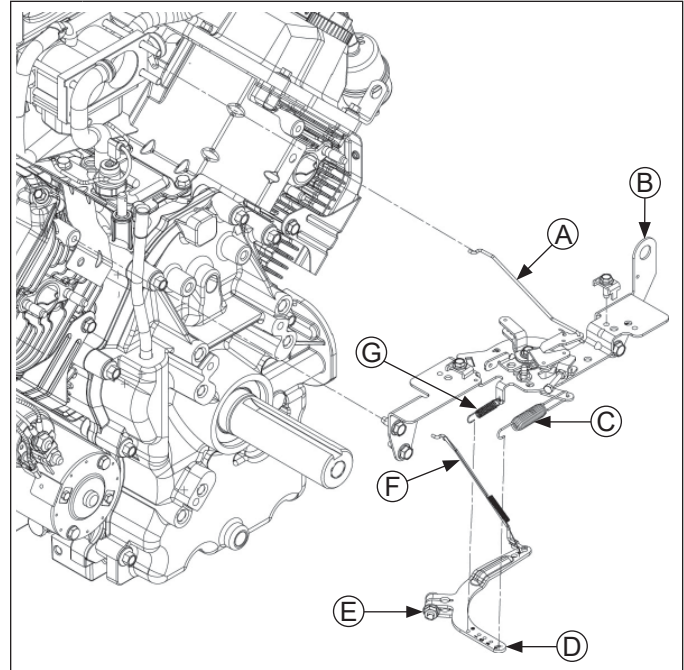

A	Choke Linkage	B	Control Bracket
C	Governor Spring	D	Governor Lever
E	Nut	F	Throttle Linkage
G	Governed Idle Spring		

Install External Governor Controls

1. Install governor lever onto governor cross shaft.
2. Make sure throttle linkage is connected to governor lever and throttle lever on carburetor.
3. Move governor lever toward carburetor as far as it will go (wide-open throttle) and hold in position.
4. Insert a nail into hole on cross shaft and rotate shaft counterclockwise as far as it will turn, then torque nut to 6.8 N·m (60 in. lb.).
5. Reconnect lead wire to fuel shut-off solenoid if equipped.

Install Throttle & Choke Controls

1. Connect choke linkage to carburetor and choke actuator lever.
2. Mount main control bracket, and air cleaner support bracket (if used) to cylinder heads using four screws. Torque screws to 10.7 N·m (95 in. lb.) into new holes, or 7.3 N·m (65 in. lb.) into used holes.
3. Connect governor spring from main control bracket to appropriate hole in governor lever as indicated in applicable chart. Note that hole positions are counted from pivot point of governor lever.

Governor Lever Hole Position

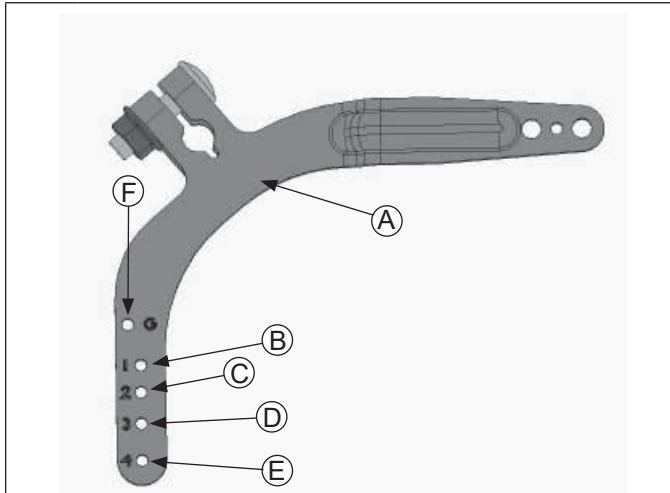

A	Governor Lever	B	Hole 1
C	Hole 2	D	Hole 3
E	Hole 4	F	Hole G

Governor Lever and Hole Position/RPM Chart (Governed Idle, 10% Regulation)

Governed Idle Spring Assembled in Hole G

High Idle RPM	Gov. Lever Hole No.	Governor Spring Color Code
3900	3	Black
3850	3	Black
3800	2	Orange
3750	2	Orange
3700	3	Clear
3650	2	Blue
3600	2	Red
3550	2	Clear
3500	2	Clear
3450	2	Clear
3400	1	Black
3350	1	Red
3300	1	Red
3250	3	Yellow

Install Oil Sentry™ (if equipped)

1. Apply pipe sealant with Teflon® (Loctite® PST® 592™ or equivalent) to threads of Oil Sentry™ switch and install it into breather cover. Torque to 4.5 N·m (40 in. lb.).
2. Connect wire lead (green) to Oil Sentry™ terminal.

Install Control Panel (if equipped)

1. Install panel to blower housing.
2. Connect throttle control cable or shaft.
3. Connect choke control cable to control bracket.
4. Connect Oil Sentry™ indicator light wires.

Install Valve Covers

Torque Sequence

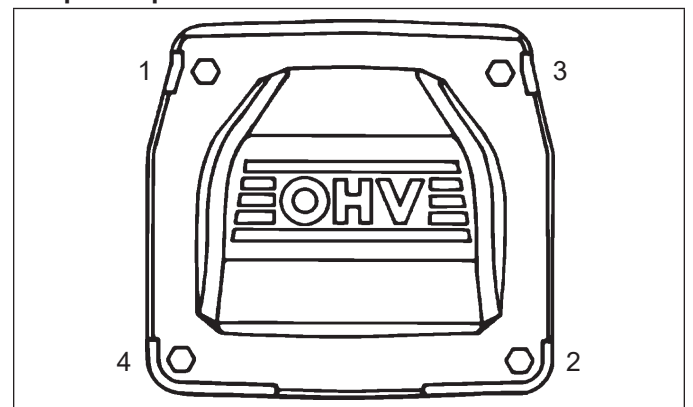

1. Make sure sealing surfaces are clean.
2. Make sure there are no nicks or burrs on sealing surfaces.
3. Install a new O-ring in groove of each cover.
4. Locate cover with oil fill neck on same side as removed and install lifting strap in original position. Position cover on cylinder head. Install four screws in each cover and finger tighten.
5. Torque valve cover fasteners to 9.0 N·m (80 in. lb.) using sequence shown.

Reassembly

Install Air Cleaner Assembly

Torque Sequence

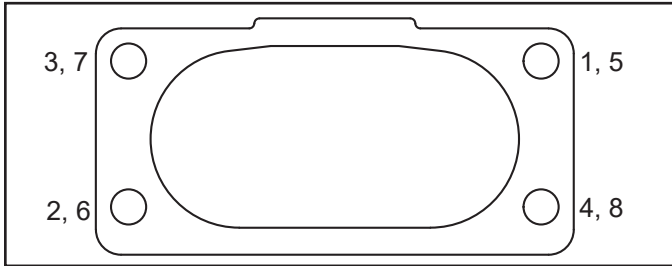

1. Connect breather hose to breather cover and fitting on adapter elbow. Route fuel line adjacent to fuel solenoid, and secure to carburetor inlet with a clamp.
2. Install a new air cleaner gasket. Make sure all holes align and are open.
3. Align air cleaner mounting bracket (if equipped) with valve cover mounting holes and start screws.
4. Install air cleaner assembly onto mounting studs. Secure with hex flange nuts. Torque nuts in 2 stages: first to 7.3 N·m (65 in. lb.), then finally to 8.2 N·m (73 in. lb.), using sequence shown. Start two mounting screws into top of intake manifold.
5. Check alignment of bracket and torque valve cover screws as prescribed in Install Valve Covers. Torque upper mounting screws into manifold to 9.9 N·m (88 in. lb.).
6. Connect air cleaner hose to elbow or adapter on carburetor and secure with a clamp.

Install Muffler

1. Install port liners (if equipped). Install muffler and attaching hardware to muffler bracket. Torque screws to 9.9 N·m (88 in. lb.).
2. Install nuts to exhaust studs. Torque nuts to 24.4 N·m (216 in. lb.).

Install Oil Cooler (if equipped)

1. Secure adapter to closure plate with oil filter nipple. Torque oil filter nipple to 27 N·m (20 ft. lb.).
2. Install screws and secure oil cooler to blower housing.

Install Oil Filter and Fill Crankcase with Oil

NOTE: Make sure both oil drain plugs are installed and torqued to specifications to prevent oil leakage.

1. Install oil drain plug(s). Torque plug(s) to 13.6 N·m (10 ft. lb.). If oil drain valve is used, make sure valve body is closed and cap is on.
2. Place new filter in shallow pan with open end up. Fill with new oil until oil reaches bottom of threads. Allow 2 minutes for oil to be absorbed by filter material.
3. Apply a thin film of clean oil to rubber gasket on oil filter.
4. Refer to instructions on oil filter for proper installation.
5. Fill crankcase with new oil. Level should be at top of indicator on dipstick.
6. Reinstall oil fill cap/dipstick and tighten securely.

Connect Spark Plug Leads

Connect leads to spark plugs.

Prepare Engine for Operation

Engine is now completely reassembled. Before starting or operating engine, be sure to follow these steps.

1. Make sure all hardware is tightened securely.
2. Make sure oil drain plugs, Oil Sentry™ pressure switch, and a new oil filter are installed.
3. Adjust carburetor idle speed adjusting screw as necessary.

Testing Engine

It is recommended engine be operated on a test stand or bench prior to installation in piece of equipment.

1. Set engine up on a test stand. Install an oil pressure gauge. Start engine and check to be certain oil pressure (20 psi or more) is present. Run engine at idle for 2-3 minutes, then 5-6 minutes more between idle and midrange. Adjust carburetor mixture settings as necessary (as available).
2. Adjust idle speed screw and high-speed stop as necessary. Make sure maximum engine speed does not exceed 3750 RPM (no load).



1P24 690 34



8 85612 22193 3