

Command PRO EFI

PCH680, PCH740

Service Manual

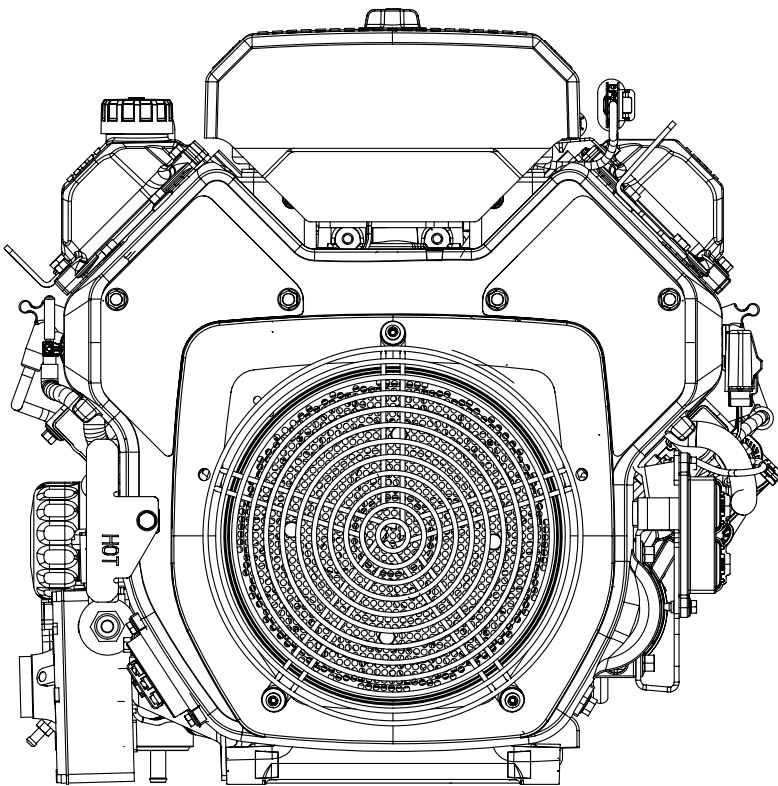

Kohler Engines
is now Rehlko.

2	Safety
3	Maintenance
5	Specifications
14	Tools and Aids
17	Troubleshooting
21	Air Cleaner/Intake
22	Propane Electronic Fuel Injection (EFI) System
52	Lubrication System
54	Electrical System
59	Starter System
63	Disassembly/Inspection and Service
80	Reassembly

IMPORTANT: Read all safety precautions and instructions carefully before operating equipment. Refer to operating instruction of equipment that this engine powers.

Ensure engine is stopped and level before performing any maintenance or service.

Safety

SAFETY PRECAUTIONS

⚠ WARNING: A hazard that could result in death, serious injury, or substantial property damage.

⚠ CAUTION: A hazard that could result in minor personal injury or property damage.

NOTE: is used to notify people of important installation, operation, or maintenance information.

	⚠ WARNING
	<p>Explosive Fuel can cause fires and severe burns.</p> <p>If a gaseous odor is detected, ventilate area and contact an authorized service technician.</p>
<p>Propane is extremely flammable and is heavier than air and tends to settle in low areas where a spark or flame could ignite gas. Do not start or operate this engine in a poorly ventilated area where leaking gas could accumulate and endanger safety of persons in area.</p> <p>To ensure personal safety, installation and repair of propane fuel supply systems must be performed only by qualified propane system technicians. Improperly installed and maintained propane equipment could cause fuel supply system or other components to malfunction, causing gas leaks.</p> <p>Observe federal, state and local laws governing propane fuel, storage, and systems.</p>	

	⚠ WARNING
	<p>Rotating Parts can cause severe injury.</p> <p>Stay away while engine is in operation.</p>
<p>Keep hands, feet, hair, and clothing away from all moving parts to prevent injury. Never operate engine with covers, shrouds, or guards removed.</p>	

	⚠ CAUTION
	<p>Failure to utilize or reassemble debris screen as designed could result in debris screen failure and serious personal injury.</p>

	⚠ WARNING
	<p>Carbon Monoxide can cause severe nausea, fainting or death.</p> <p>Take precautions against exposure to carbon monoxide (CO) emissions. Only operate an engine in well ventilated areas.</p>
<p>Engine exhaust gases contain poisonous carbon monoxide. Carbon monoxide is odorless, colorless, and can cause death if inhaled.</p>	

	⚠ WARNING
	<p>Accidental Starts can cause severe injury or death.</p> <p>Disconnect and ground spark plug lead(s) before servicing.</p>
<p>Before working on engine or equipment, disable engine as follows: 1) Disconnect spark plug lead(s). 2) Disconnect negative (-) battery cable from battery.</p>	

	⚠ WARNING
	<p>Hot Parts can cause severe burns.</p> <p>Do not touch engine while operating or just after stopping.</p>
<p>Never operate engine with heat shields or guards removed.</p>	



	⚠ WARNING
	<p>Cleaning Solvents can cause severe injury or death.</p> <p>Use only in well ventilated areas away from ignition sources.</p>
<p>Carburetor cleaners and solvents are extremely flammable. Follow cleaner manufacturer's warnings and instructions on its proper and safe use. Never use gasoline as a cleaning agent.</p>	

	⚠ CAUTION
	<p>Electrical Shock can cause injury.</p> <p>Do not touch wires while engine is running.</p>

	⚠ CAUTION
	<p>Damaging Crankshaft and Flywheel can cause personal injury.</p>
<p>Using improper procedures can lead to broken fragments. Broken fragments could be thrown from engine. Always observe and use precautions and procedures when installing flywheel.</p>	

	⚠ WARNING
	<p>High Pressure Fluids can puncture skin and cause severe injury or death.</p> <p>Do not work on fuel system without proper training or safety equipment.</p>
<p>Fluid puncture injuries are highly toxic and hazardous. If an injury occurs, seek immediate medical attention.</p>	

MAINTENANCE INSTRUCTIONS

  	⚠ WARNING	Before working on engine or equipment, disable engine as follows: 1) Disconnect spark plug lead(s). 2) Disconnect negative (-) battery cable from battery.
	Accidental Starts can cause severe injury or death. Disconnect and ground spark plug lead(s) before servicing.	

Normal maintenance, replacement or repair of emission control devices and systems may be performed by any repair establishment or individual; however, warranty repairs must be performed by a Rehlko authorized dealer.

MAINTENANCE SCHEDULE

Every 25 Hours¹

<ul style="list-style-type: none"> Service/replace low-profile precleaner (if equipped). 	Air Cleaner/Intake
---	--------------------

Every 100 Hours¹

<ul style="list-style-type: none"> Check oil cooler fins, clean as necessary (if equipped). 	Air Cleaner/Intake
<ul style="list-style-type: none"> Change oil. 	Lubrication System
<ul style="list-style-type: none"> Replace low-profile air cleaner element (if equipped). 	Air Cleaner/Intake
<ul style="list-style-type: none"> Remove cooling shrouds and clean cooling areas. 	Air Cleaner/Intake

Every 150 Hours¹

<ul style="list-style-type: none"> Check heavy-duty filter minder. 	Air Cleaner/Intake
<ul style="list-style-type: none"> Inspect heavy-duty air filter paper element and inlet screen area. 	Air Cleaner/Intake

Every 200 Hours¹

<ul style="list-style-type: none"> Change oil filter. 	Lubrication System
<ul style="list-style-type: none"> Replace unique EFI fuel filters. 	

Every 300 Hours¹

<ul style="list-style-type: none"> Replace heavy-duty air cleaner element and check inner element. 	Air Cleaner/Intake
---	--------------------

Every 300 Hours³

<ul style="list-style-type: none"> Change oil and filter (Xtended Life PRO 10W-50 oil and Xtended Life PRO filter only). 	Lubrication System
---	--------------------

Every 500 Hours or Annually¹

<ul style="list-style-type: none"> Check all lines (high pressure/vacuum) including fittings for leaks. 	Fuel System
<ul style="list-style-type: none"> Drain vaporizer/regulator of accumulated fuel deposits. 	Fuel System
<ul style="list-style-type: none"> Replace spark plugs and set gap. 	Electrical System

Every 500 Hours or Annually^{1,2}

<ul style="list-style-type: none"> Inspect lock-off assembly for damage/leakage. 	Fuel System
---	-------------

Every 600 Hours or Annually¹

<ul style="list-style-type: none"> Replace heavy-duty air cleaner inner element. 	Air Cleaner/Intake
---	--------------------

Every 1500 Hours^{1,2}

<ul style="list-style-type: none"> Have vaporizer/regulator tested. 	Fuel System
--	-------------

¹ Perform these procedures more frequently under severe, dusty, dirty conditions.

² Must be performed by a Rehlko authorized dealer or qualified propane personnel only. ³ Option only if using Xtended Life PRO oil and Xtended Life PRO filter.

REPAIRS/SERVICE PARTS

Rehlko genuine service parts can be purchased from Rehlko authorized dealers. To find a local authorized dealer visit engines.rehlko.com or call 1-800-544-2444 (U.S. and Canada).

Maintenance

OIL RECOMMENDATIONS

All-season Xtended Life PRO 10W-50 Synthetic Oil is the ideal oil for Rehlko engines. It is specifically formulated to extend the oil and oil filter change interval to 300 Hours when paired with a Xtended Life PRO Oil Filter.

300-Hour oil and oil filter change intervals are exclusive to and only authorized on Rehlko engines that utilize both the Xtended Life PRO 10W-50 Synthetic Oil and Xtended Life PRO Oil Filter. Alternative engine oils and oil filters may be used with Rehlko engines but require 100-Hour oil and 200-Hour oil filter change intervals for proper maintenance. Oil must be API (American Petroleum Institute) service class SJ or higher. Select viscosity based on air temperature at time of operation as shown below.

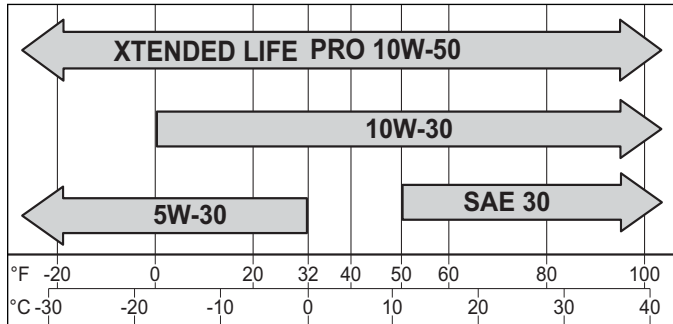

STORAGE

If engine will be out of service for 2 months or more follow procedure below.

1. Change oil while engine is still warm from operation (NOT required if using Xtended Life PRO 10W-50 full-synthetic oil). Remove spark plug(s) and pour about 1 oz. of engine oil into cylinder(s). Replace spark plug(s) and crank engine slowly to distribute oil.
2. Disconnect negative (-) battery cable.
3. Separate propane tank from unit and store separately in an area designated for safe propane tank storage.
4. Store engine in a clean, dry place.

FUEL RECOMMENDATIONS

	⚠ WARNING
	<p>Explosive Fuel can cause fires and severe burns.</p> <p>If a gaseous odor is detected, ventilate area and contact an authorized service technician.</p>
<p>Propane is extremely flammable and is heavier than air and tends to settle in low areas where a spark or flame could ignite gas. Do not start or operate this engine in a poorly ventilated area where leaking gas could accumulate and endanger safety of persons in area.</p> <p>To ensure personal safety, installation and repair of propane fuel supply systems must be performed only by qualified propane system technicians. Improperly installed and maintained propane equipment could cause fuel supply system or other components to malfunction, causing gas leaks.</p> <p>Observe federal, state and local laws governing propane fuel, storage, and systems.</p>	

This engine is certified to operate on commercial propane with a minimum propane content of 85% (per GPA STD 2140). If you have any questions, contact your propane supplier.

This engine requires propane fuel in a gaseous/vapor source from a supply tank designed for use with gaseous/vapor draw.

Propane from an appropriate propane fuel tank (supplied separately) is required to operate this engine.

Specifications

Engine Dimensions with Low-Profile Air Cleaner

Dimensions in millimeters.
Inch equivalents shown in [].

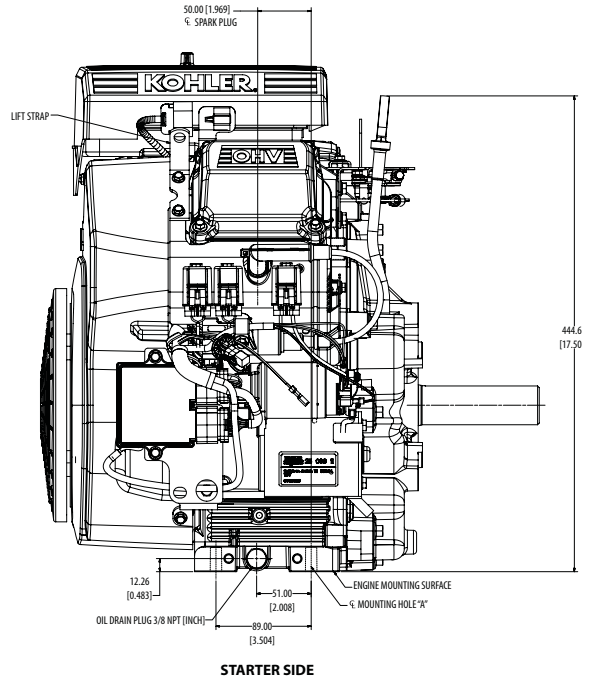
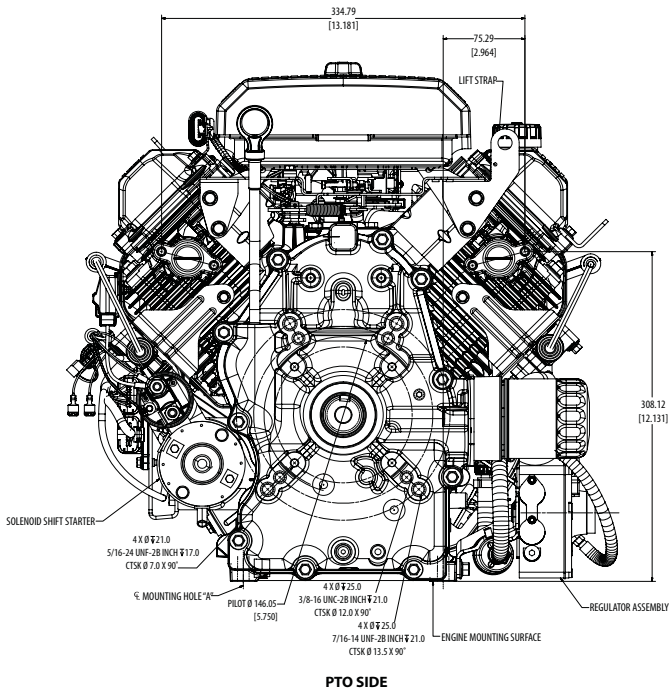
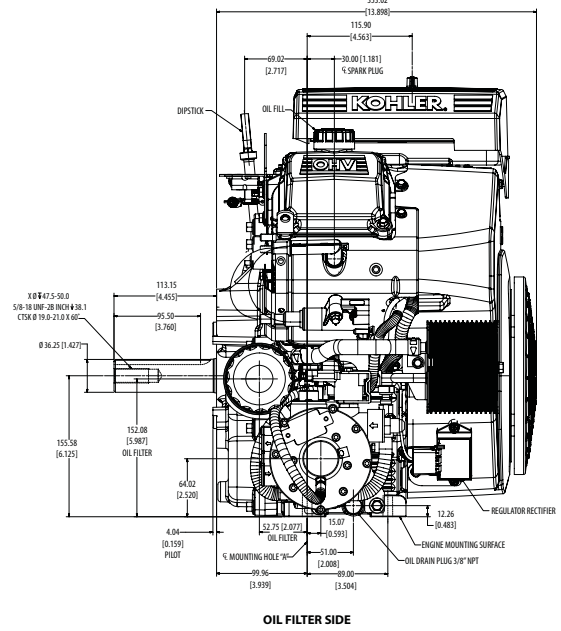
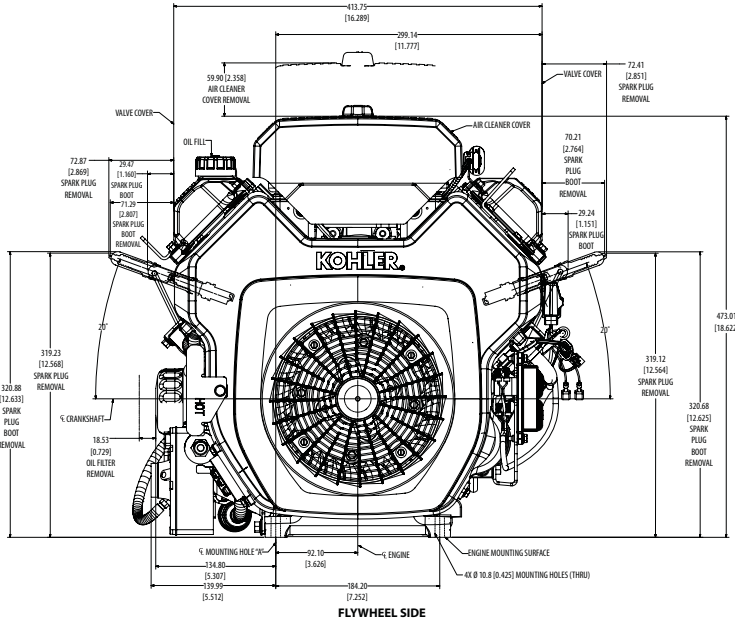

ENGINE IDENTIFICATION NUMBERS

Rehiko engine identification numbers (model, specification and serial) should be referenced for efficient repair, ordering correct parts, and engine replacement.

Model	PCH680			
Propane EFI Command Engine	}			
Horizontal Shaft				
Numerical Designation				
Specification	PCH680-3001			
Serial	4923500328			
Year Manufactured Code	49 2019	50 2020	51 2021	Factory Code
	<u>Code</u>	<u>Year</u>		
	49	2019		
	50	2020		
	51	2021		

GENERAL SPECIFICATIONS^{4,7}

PCH680, PCH740

Bore	83 mm (3.27 in.)
Stroke	69 mm (2.72 in.)
Displacement	747 cc (45.6 cu. in.)
Oil Capacity (refill)	1.6-1.9 L (1.7-2.0 U.S. qt.)
Maximum Angle of Operation (@ full oil level) ⁵	25°

TORQUE SPECIFICATIONS^{4,6}

PCH680, PCH740

Blower Housing

Into cored aluminum hole or weld nut M5	6.2 N·m (55 in. lb.) into new holes 4.0 N·m (35 in. lb.) into used holes
M6	10.7 N·m (95 in. lb.) into new holes 7.3 N·m (65 in. lb.) into used holes
Into extruded hole in sheet metal M5	2.8 N·m (25 in. lb.) into new holes 2.3 N·m (20 in. lb.) into used holes
M6	2.8 N·m (25 in. lb.) into new holes 2.3 N·m (20 in. lb.) into used holes

Closure Plate

Fastener	25.6 N·m (227 in. lb.)
----------	------------------------

Connecting Rod

Cap Fastener (torque in increments)	13.6 N·m (120 in. lb.)
-------------------------------------	------------------------

⁴ Values are in Metric units. Values in parentheses are English equivalents.

⁵ Exceeding maximum angle of operation may cause engine damage from insufficient lubrication.

⁶ Lubricate threads with engine oil prior to assembly.

⁷ Any and all horsepower (hp) references by Rehiko are Certified Power Ratings and per SAE J1940 & J1995 hp standards. Details on Certified Power Ratings can be found at engines.rehiko.com.

Specifications

TORQUE SPECIFICATIONS^{4,6}

PCH680, PCH740

Crankcase

Breather Cover Fastener	11.3 N·m (100 in. lb.) into new holes 7.3 N·m (65 in. lb.) into used holes
Oil Temperature Sensor (into breather cover)	7.3 N·m (65 in. lb.)
Oil Drain Plug	13.6 N·m (10 ft. lb.)

Cylinder Head

Hex Flange Nut (torque in 2 increments)	first to 16.9 N·m (150 in. lb.) finally to 33.9 N·m (300 in. lb.)
Rocker Arm Screw Black Screw (M6x1.0x34) Silver Screw (M6x1.0x45)	18.1 N·m (160 in. lb.) 13.6 N·m (120 in. lb.)

Fan/Flywheel

Flywheel Retaining Screw	71.6 N·m (52.8 ft. lb.)
Metal Debris Screen Fastener (to flywheel)	9.9 N·m (88 in. lb.)

Fuel Vaporizer/Regulator/Lock-Off

Regulator to Bracket Nut	19.8 N·m (175 in. lb.)
Regulator Bracket Mounting Screw	11.9 N·m (105 in. lb.)
Lock-Off Valve Body Nut	6.5 N·m (57 in. lb.)
Lock-Off Valve Body	20 N·m (177 in. lb.)
Fuel Outlet Fitting Mounting Screws	2.9 N·m (26 in. lb.)
Fuel Inlet Fitting	20 N·m (177 in. lb.)

Governor

Lever Nut	7.1 N·m (63 in. lb.)
-----------	----------------------

Ignition

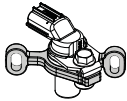
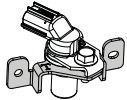
Spark Plug	27 N·m (20 ft. lb.)
Coil Fastener	10.2 N·m (90 in. lb.)
Electronic Control Unit Screw	6.2 N·m (55 in. lb.)
Rectifier-Regulator Ground Strap/Ground Lead Fastener (into backing plate)	2.8 N·m (25 in. lb.) into new holes 2.3 N·m (20 in. lb.) into used holes
Rectifier-Regulator Ground Lead Fastener to Ground Lug/Backing Plate	5.6 N·m (50 in. lb.) into new holes 4.0 N·m (35 in. lb.) into used holes
Rectifier-Regulator Fastener	1.4 N·m (12.6 in. lb.)
Crankshaft Position Sensor Earlier Design Bracket	
Crankshaft Position Sensor to Bracket Screw	11.3 N·m (100 in. lb.)
Crankshaft Position Sensor Bracket to Crankcase Screw	8.3 N·m (73 in. lb.)
Crankshaft Position Sensor Later Design Bracket	
Crankshaft Position Sensor to Bracket Screw	6.8 N·m (60 in. lb.)
Crankshaft Position Sensor Bracket to Crankcase Screw	7.3 N·m (65 in. lb.)

⁴ Values are in Metric units. Values in parentheses are English equivalents.

⁶ Lubricate threads with engine oil prior to assembly.

Specifications

TORQUE SPECIFICATIONS^{4,6}

PCH680, PCH740

Intake Manifold

Fastener (torque in 2 increments)	first to 7.8 N·m (69 in. lb.) finally to 10.5 N·m (93 in. lb.)
Manifold Absolute Pressure (MAP) Sensor Fastener (Engines with Separate MAP and Intake Air Temperature Sensors)	7.3 N·m (65 in. lb.)
Temperature/Manifold Absolute Pressure (TMAP) Sensor Fastener (Engines with Combined Sensor)	7.3 N·m (65 in. lb.)
Air Cleaner to Throttle Body Fastener Nut	8.2 N·m (73 in. lb.)
Air Cleaner Mounting Bracket Fastener	5.8 N·m (51 in. lb.)
Fuel Injector Cap Fastener	7.3 N·m (65 in. lb.)

Muffler

Retaining Nut	27.8 N·m (246 in. lb.)
Oxygen Sensor	50.1 N·m (37 ft . lb.)

Oil Cooler

Oil Cooler/Adapter Nipple	28.5 N·m (21 ft . lb.)
Fastener Into Blower Housing Between Oil Cooler Hoses	2.8 N·m (25 in. lb.) 2.3 N·m (20 in. lb.)

Speed Control Bracket

Fastener assembled to cylinder heads	10.7 N·m (95 in. lb.) into new holes 7.3 N·m (65 in. lb.) into used holes
Fastener assembled to blower housing	2.8 N·m (25 in. lb.) into new holes 2.3 N·m (20 in. lb.) into used holes

Starter Assembly

Thru Bolt	5.6-9.0 N·m (49-79 in. lb.)
Mounting Screw	16.0 N·m (142 in. lb.)
Brush Holder Mounting Screw	2.5-3.3 N·m (22-29 in. lb.)

Starter Solenoid

Mounting Hardware	4.0-6.0 N·m (35-53 in. lb.)
Nut, Positive (+) Brush Lead	8.0-11.0 N·m (71-97 in. lb.)

Stator

Mounting Screw	6.2 N·m (55 in. lb.) into new holes 4.0 N·m (35 in. lb.) into used holes
----------------	---

Valve Cover

Fastener	9.0 N·m (80 in. lb.)
----------	----------------------

⁴ Values are in Metric units. Values in parentheses are English equivalents.

⁶ Lubricate threads with engine oil prior to assembly.

Specifications

CLEARANCE SPECIFICATIONS⁴

PCH680, PCH740

Camshaft

End Play (with shim)	0.101/0.406 mm (0.0040/0.0160 in.)
Running Clearance	0.025/0.105 mm (0.001/0.004 in.)
Bore I.D. New Max. Wear Limit	20.000/20.025 mm (0.7874/0.7884 in.) 20.038 mm (0.7889 in.)
Bearing Surface O.D. New Max. Wear Limit	19.920/19.975 mm (0.7843/0.7864 in.) 19.914 mm (0.7840 in.)

Connecting Rod

Connecting Rod-to-Crankpin Running Clearance @ 21°C (70°F) New Max. Wear Limit	0.043/0.073 mm (0.0017/0.0029 in.) 0.088 mm (0.0035 in.)
Connecting Rod-to-Crankpin Side Clearance	0.26/0.63 mm (0.0102/0.0248 in.)
Connecting Rod-to-Piston Pin Running Clearance @ 21°C (70°F)	0.015/0.028 mm (0.0006/0.0011 in.)
Piston Pin End I.D. @ 21°C (70°F) New Max. Wear Limit	17.015/17.023 mm (0.6699/0.6702 in.) 17.036 mm (0.6707 in.)

Crankcase

Governor Cross Shaft Bore I.D. New Max. Wear Limit	8.025/8.075 mm (0.3159/0.3179 in.) 8.088 mm (0.3184 in.)
--	---

Crankshaft

End Play (free)	0.025/0.635 mm (0.001/0.025 in.)
Bore (in crankcase) New Max. Wear Limit	40.972/40.997 mm (1.6131/1.6141 in.) 41.011 mm (1.6146 in.)
Bore (in closure plate) New	40.974/41.000 mm (1.6131/1.6141 in.)
Crankshaft to Sleeve Bearing (closure plate) Running Clearance New	0.03/0.12 mm (0.001/0.005 in.)
Crankshaft Bore (closure plate)-to-Crankshaft Running Clearance New	0.039/0.087 mm (0.0015/0.0034 in.)
Flywheel End Main Bearing Journal O.D. - New O.D. - Max. Wear Limit Max. Taper Limit Max. Out-of-Round Limit	40.913/40.935 mm (1.6107/1.6116 in.) 40.843 mm (1.608 in.) 0.022 mm (0.0009 in.) 0.025 mm (0.0010 in.)

⁴ Values are in Metric units. Values in parentheses are English equivalents.

⁶ Lubricate threads with engine oil prior to assembly.

CLEARANCE SPECIFICATIONS⁴

PCH680, PCH740

Crankshaft (continued)

Closure Plate End Main Bearing Journal	
O.D. - New	40.913/40.935 mm (1.6107/1.6116 in.)
O.D. - Max. Wear Limit	40.843 mm (1.608 in.)
Max. Taper Limit	0.022 mm (0.0009 in.)
Max. Out-of-Round Limit	0.025 mm (0.0010 in.)
Connecting Rod Journal	
O.D. - New	35.950/35.973 mm (1.4153/1.4163 in.)
O.D. - Max. Wear Limit	35.941 mm (1.415 in.)
Max. Taper Limit	0.018 mm (0.0007 in.)
Max. Out-of-Round Limit	0.025 mm (0.0010 in.)
Crankshaft T.I.R.	
PTO End, Crank in Engine	0.279 mm (0.0110 in.)
Entire Crank, in V-Blocks	0.10 mm (0.0039 in.)

Cylinder Bore

Bore I.D.	
New	83.006/83.031 mm (3.2680/3.2689 in.)
O.D. - Max. Wear Limit	83.081 mm (3.2709 in.)
Max. Out-of-Round Limit	0.120 mm (0.0047 in.)
Max. Taper	0.05 mm (0.0020 in.)

Cylinder Head

Max. Out-of-Flatness	0.076 mm (0.003 in.)
----------------------	----------------------

Governor

Governor Cross Shaft -to-Crankcase Running Clearance	0.025/0.126 mm (0.0009/0.0049 in.)
Cross Shaft O.D.	
New	7.949/8.000 mm (0.3129/0.3149 in.)
Max. Wear Limit	7.936 mm (0.3124 in.)
Governor Gear Shaft -to-Governor Gear Running Clearance	0.090/0.160 mm (0.0035/0.0063 in.)
Gear Shaft O.D.	
New	5.990/6.000 mm (0.2358/0.2362 in.)
Max. Wear Limit	5.977 mm (0.2353 in.)

Ignition

Spark Plug Gap	0.76 mm (0.030 in.)
Crankshaft Position Sensor Air Gap (only on earlier design sensor bracket)	0.2-0.7 mm (0.008-0.027 in.)
Crankshaft Position Sensor Max. Air Gap (only on later design sensor bracket)	2.794 mm (0.110 in.)

⁴ Values are in Metric units. Values in parentheses are English equivalents.

Specifications

CLEARANCE SPECIFICATIONS⁴

PCH680, PCH740

Piston, Piston Rings, and Piston Pin

Piston-to-Piston Pin Running Clearance	0.006/0.017 mm (0.0002/0.0007 in.)
Pin Bore I.D. New Max. Wear Limit	17.006/17.012 mm (0.6695/0.6698 in.) 17.025 mm (0.6703 in.)
Pin O.D. New Max. Wear Limit	16.995/17.000 mm (0.6691/0.6693 in.) 16.994 mm (0.6691 in.)
Top Compression Ring-to-Groove Side Clearance	0.030/0.070 mm (0.001/0.0026 in.)
Middle Compression Ring-to-Groove Side Clearance	0.030/0.070 mm (0.001/0.0026 in.)
Oil Control Ring-to-Groove Side Clearance	0.060/0.190 mm (0.0022/0.0073 in.)
Top Compression Ring End Gap New Bore	0.189/0.277 mm (0.0074/0.0109 in.)
Used Bore (Max.)	0.531 mm (0.0209 in.)
Center Compression Ring End Gap New Bore	1.519/1.797 mm (0.0598/0.0708 in.)
Used Bore (Max.)	2.051 mm (0.0808 in.)
Thrust Face O.D. ⁸ Max. Wear Limit	82.978 mm (3.2668 in.) 82.833 mm (3.2611 in.)
Piston Thrust Face-to Cylinder Bore ⁸ Running Clearance New	0.019/0.062 mm (0.0007/0.0024 in.)



Valves and Valve Lifters

Hydraulic Lifter to Crankcase Running Clearance	0.011/0.048 mm (0.0004/0.0019 in.)
Intake Valve Stem-to-Valve Guide Running Clearance	0.040/0.078 mm (0.0016/0.0031 in.)
Exhaust Valve Stem-to-Valve Guide Running Clearance	0.052/0.090 mm (0.0020/0.0035 in.)
Intake Valve Guide I.D. New Max. Wear Limit	7.040/7.060 mm (0.2772/0.2780 in.) 7.134 mm (0.2809 in.)
Exhaust Valve Guide I.D. New Max. Wear Limit	7.040/7.060 mm (0.2772/0.2780 in.) 7.159 mm (0.2819 in.)
Valve Guide Reamer Size Standard 0.25 mm O.S.	7.050 mm (0.2776 in.) 7.300 mm (0.2874 in.)
Intake Valve Minimum Lift	8.07 mm (0.3177 in.)
Exhaust Valve Minimum Lift	8.07 mm (0.3177 in.)
Nominal Valve Seat Angle	45°





⁴ Values are in Metric units. Values in parentheses are English equivalents.

⁸ Measure 6 mm (0.236 in.) above bottom of piston skirt at right angles to piston pin.

GENERAL TORQUE VALUES

English Fastener Torque Recommendations for Standard Applications				
Bolts, Screws, Nuts and Fasteners Assembled Into Cast Iron or Steel				Grade 2 or 5 Fasteners Into Aluminum
Size	 Grade 2	 Grade 5	 Grade 8	
Tightening Torque: N·m (in. lb.) ± 20%				
8-32	2.3 (20)	2.8 (25)	—	2.3 (20)
10-24	3.6 (32)	4.5 (40)	—	3.6 (32)
10-32	3.6 (32)	4.5 (40)	—	—
1/4-20	7.9 (70)	13.0 (115)	18.7 (165)	7.9 (70)
1/4-28	9.6 (85)	15.8 (140)	22.6 (200)	—
5/16-18	17.0 (150)	28.3 (250)	39.6 (350)	17.0 (150)
5/16-24	18.7 (165)	30.5 (270)	—	—
3/8-16	29.4 (260)	—	—	—
3/8-24	33.9 (300)	—	—	—

Tightening Torque: N·m (ft. lb.) ± 20%				
5/16-24	—	—	40.7 (30)	—
3/8-16	—	47.5 (35)	67.8 (50)	—
3/8-24	—	54.2 (40)	81.4 (60)	—
7/16-14	47.5 (35)	74.6 (55)	108.5 (80)	—
7/16-20	61.0 (45)	101.7 (75)	142.5 (105)	—
1/2-13	67.8 (50)	108.5 (80)	155.9 (115)	—
1/2-20	94.9 (70)	142.4 (105)	223.7 (165)	—
9/16-12	101.7 (75)	169.5 (125)	237.3 (175)	—
9/16-18	135.6 (100)	223.7 (165)	311.9 (230)	—
5/8-11	149.5 (110)	244.1 (180)	352.6 (260)	—
5/8-18	189.8 (140)	311.9 (230)	447.5 (330)	—
3/4-10	199.3 (147)	332.2 (245)	474.6 (350)	—
3/4-16	271.2 (200)	440.7 (325)	637.3 (470)	—

Metric Fastener Torque Recommendations for Standard Applications						
Size	Property Class					Noncritical Fasteners Into Aluminum
						
Tightening Torque: N·m (in. lb.) ± 10%						
M4	1.2 (11)	1.7 (15)	2.9 (26)	4.1 (36)	5.0 (44)	2.0 (18)
M5	2.5 (22)	3.2 (28)	5.8 (51)	8.1 (72)	9.7 (86)	4.0 (35)
M6	4.3 (38)	5.7 (50)	9.9 (88)	14.0 (124)	16.5 (146)	6.8 (60)
M8	10.5 (93)	13.6 (120)	24.4 (216)	33.9 (300)	40.7 (360)	17.0 (150)
Tightening Torque: N·m (ft. lb.) ± 10%						
M10	21.7 (16)	27.1 (20)	47.5 (35)	66.4 (49)	81.4 (60)	33.9 (25)
M12	36.6 (27)	47.5 (35)	82.7 (61)	116.6 (86)	139.7 (103)	61.0 (45)
M14	58.3 (43)	76.4 (56)	131.5 (97)	184.4 (136)	219.7 (162)	94.9 (70)

Torque Conversions	
N·m = in. lb. x 0.113	in. lb. = N·m x 8.85
N·m = ft. lb. x 1.356	ft. lb. = N·m x 0.737

Tools and Aids

Certain quality tools are designed to help you perform specific disassembly, repair, and reassembly procedures. By using these tools, you can properly service engines easier, faster, and safer! In addition, you'll increase your service capabilities and customer satisfaction by decreasing engine downtime.

Here is a list of tools and their source.

NOTE: Not all tools listed are required to service this engine.

SEPARATE TOOL SUPPLIERS

Rehiko Tools
Contact your local Rehiko source
of supply.

SE Tools
415 Howard St.
Lapeer, MI 48446
Phone 810-664-2981
Toll Free 800-664-2981
Fax 810-664-8181

Design Technology Inc.
768 Burr Oak Drive
Westmont, IL 60559
Phone 630-920-1300
Fax 630-920-0011

TOOLS

Description	Source/Part No.
Alcohol Content Tester For testing alcohol content (%) in reformulated/oxygenated fuels.	Rehiko 25 455 11-S
Camshaft Endplay Plate For checking camshaft endplay.	SE Tools KLR-82405
Camshaft Seal Protector (Aegis) For protecting seal during camshaft installation.	SE Tools KLR-82417
Dual Gauge Cylinder Leakdown Tester For checking combustion retention and if cylinder, piston, rings, or valves are worn. Individual component available: Adapter 12 mm x 14 mm (Required for leakdown test on XT-6 engines)	Rehiko 25 761 46-S Design Technology Inc. DTI-731-03
Dealer Tool Kit Complete kit of Rehiko required tools. Components of 25 761 39-S Ignition System Tester Dual Gauge Cylinder Leakdown Test Tool Oil Pressure Test Kit Digital Vacuum/Pressure Tester	Rehiko 25 761 39-S Rehiko 25 455 01-S Rehiko 25 761 46-S Rehiko 25 761 06-S Rehiko 25 455 22-S
Digital Vacuum/Pressure Tester For checking crankcase vacuum. Individual component available: Rubber Adapter Plug	Rehiko 25 455 22-S Design Technology Inc. DTI-721-10
EFI Service Kit For troubleshooting and setting up an EFI engine. Components of 24 761 01-S Fuel Pressure Tester Noid Light 90° Adapter Code Plug, Red Wire Code Plug, Blue Wire Code Plug, Yellow Wire Can Bus Reset Tool, Green Wire Shrader Valve Adapter Hose Wire Probe Set (2 pieces regular wire with clip; 1 piece fused wire) Hose Removal Tool, Dual Size/End (also sold as individual Rehiko tool) K-Line Adapter Jumper Lead Wiring Harness	Rehiko 24 761 01-S Design Technology Inc. DTI-019 DTI-021 DTI-023 DTI-027 DTI-029 DTI-028 DTI-030 DTI-037 DTI-031 DTI-033 Rehiko 25 176 23-S
Rehiko® Diagnostic System (KDS) Gen 2 For Laptop or Desktop PC. Components of 25 761 50-S Engine Communication Module 7 Pin to DB9 Cable USB Module to PC Cable 7 Pin to 4 Pin Adapter	Rehiko 25 761 50-S Rehiko 25 761 47-S Rehiko 25 761 48-S Rehiko 25 761 49-S Rehiko 25 761 53-S
Mobile KDS (Wireless) Module For mobile Android or iOS EFI diagnostics. Individual component available: Wireless Diagnostic System Interface Cable	Rehiko 25 761 45-S Rehiko 25 761 44-S

TOOLS

Description	Source/Part No.
Flywheel Puller For properly removing flywheel from engine.	SE Tools KLR-82408
Flywheel Anchor Bolts, Washers, Nuts Tool Used with Flywheel Puller for properly removing flywheel from 5400 Series engine.	Rehiko 25 086 753-S
Hose Removal Tool, Dual Size/End (also available in EFI Service Kit) Used to properly remove fuel hose from engine components.	Rehiko 25 455 20-S
Ignition System Tester For testing output on all systems, including CD.	Rehiko 25 455 01-S
Inductive Tachometer (Digital) For checking operating speed (RPM) of an engine.	Design Technology Inc. DTI-110
Oil Pressure Test Kit For testing/verifying oil pressure on pressure lubricated engines.	Rehiko 25 761 06-S
Rectifier-Regulator Tester (120 volt current) Rectifier-Regulator Tester (240 volt current) For testing rectifier-regulators. Components of 25 761 20-S and 25 761 41-S CS-PRO Regulator Test Harness Special Regulator Test Harness with Diode	Rehiko 25 761 20-S Rehiko 25 761 41-S Design Technology Inc. DTI-031R DTI-033R
Spark Advance Module (SAM) Tester For testing SAM (ASAM and DSAM) on engines with SMART-SPARK™.	Rehiko 25 761 40-S
Starter Servicing Kit (All Starters) For removing and reinstalling drive retaining rings and brushes. Individual component available: Starter Brush Holding Tool (Solenoid Shift)	SE Tools KLR-82411 SE Tools KLR-82416
Stepper Motor Controller Tool For testing operation of stepper motor/Digital Linear Actuator (DLA).	Rehiko 25 455 21-S
Jumper Lead Tool For use with Stepper Motor Controller Tool to test rotary stepper motor.	Rehiko 25 518 43-S
Triad/OHC Timing Tool Set For holding cam gears and crankshaft in timed position while installing timing belt.	Rehiko 28 761 01-S
Valve Guide Reamer (K and M Series) For properly sizing valve guides after installation.	Design Technology Inc. DTI-K828
Valve Guide Reamer O.S. (Command Series) For reaming worn valve guides to accept replacement oversize valves. Can be used in low-speed drill press or with handle below for hand reaming.	Rehiko 25 455 12-S
Reamer Handle For hand reaming using Rehiko 25 455 12-S reamer.	Design Technology Inc. DTI-K830

AIDS

Description	Source/Part No.
Camshaft Lubricant (Valspar ZZ613)	Rehiko 25 357 14-S
Dielectric Grease (GE/Novaguard G661)	Rehiko 25 357 11-S
Dielectric Grease	Loctite® 51360
Rehiko Electric Starter Drive Lubricant (Inertia Drive)	Rehiko 52 357 01-S
Rehiko Electric Starter Drive Lubricant (Solenoid Shift)	Rehiko 52 357 02-S
RTV Silicone Sealant Loctite® 5900® Heavy Body in 4 oz. aerosol dispenser. Only oxime-based, oil resistant RTV sealants, such as those listed, are approved for use. Permatex® the Right Stuff® 1 Minute Gasket™ or Loctite® Nos. 5900® or 5910® are recommended for best sealing characteristics.	Rehiko 25 597 07-S Loctite® 5910® Loctite® Ultra Black 598™ Loctite® Ultra Blue 587™ Loctite® Ultra Copper 5920™ Permatex® the Right Stuff® 1 Minute Gasket™
Spline Drive Lubricant	Rehiko 25 357 12-S

Tools and Aids

FLYWHEEL HOLDING TOOL

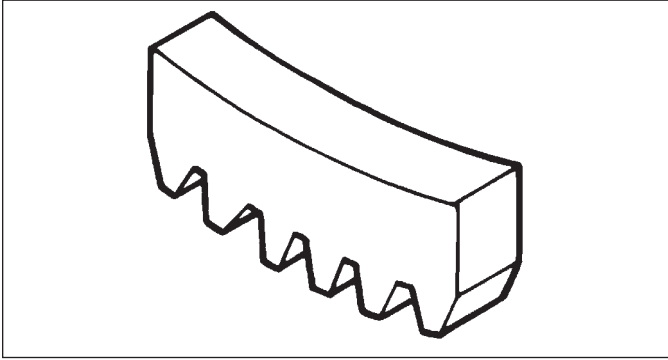

A flywheel holding tool can be made out of an old junk flywheel ring gear and used in place of a strap wrench.

1. Using an abrasive cut-off wheel, cut out a six tooth segment of ring gear as shown.
2. Grind off any burrs or sharp edges.
3. Invert segment and place it between ignition bosses on crankcase so tool teeth engage flywheel ring gear teeth. Bosses will lock tool and flywheel in position for loosening, tightening, or removing with a puller.

ROCKER ARM/CRANKSHAFT TOOL

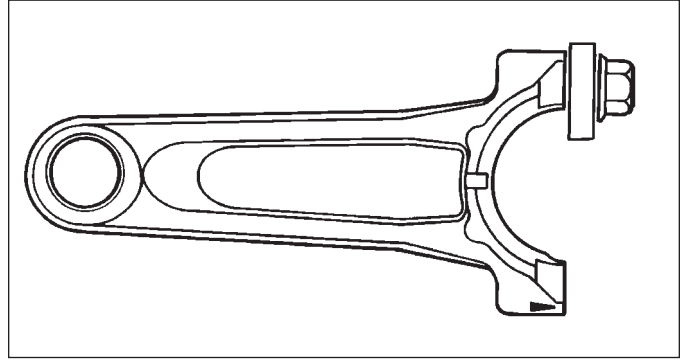

A spanner wrench to lift rocker arms or turn crankshaft may be made out of an old junk connecting rod.

1. Find a used connecting rod from a 10 HP or larger engine. Remove and discard rod cap.
2. Remove studs of a Posi-Lock rod or grind off aligning steps of a Command rod, so joint surface is flat.
3. Find a 1 in. long capscrew with correct thread size to match threads in connecting rod.
4. Use a flat washer with correct I.D. to slip on capscrew and approximately 1 in. O.D. Assemble capscrew and washer to joint surface of rod.

TROUBLESHOOTING GUIDE

When troubles occur, be sure to check simple causes which, at first, may seem too obvious to be considered. For example, a starting problem could be caused by an empty fuel tank.

Some general common causes of EFI engine troubles are listed below and vary by engine specification. Use these to locate causing factors.

Engine Cranks But Will Not Start

- Battery connected backwards.
- Blown fuse.
- Carburetor solenoid malfunction.
- Choke not closing.
- Clogged fuel line or fuel filter.
- Diode in wiring harness failed in open circuit mode.
- DSAI or DSAM malfunction.
- Empty fuel tank.
- Faulty electronic control unit.
- Faulty ignition coil(s).
- Faulty spark plug(s).
- Fuel pump malfunction-vacuum hose clogged or leaking.
- Fuel shut-off valve closed.
- Ignition module(s) faulty or improperly gapped.
- Insufficient voltage to electronic control unit.
- Interlock switch is engaged or faulty.
- Key switch or kill switch in OFF position.
- Low oil level.
- Quality of fuel (dirt, water, stale, mixture).
- SMART-SPARK™ malfunction.
- Spark plug lead(s) disconnected.

Engine Starts But Does Not Keep Running

- Faulty carburetor.
- Faulty cylinder head gasket.
- Faulty or misadjusted choke or throttle controls.
- Fuel pump malfunction-vacuum hose clogged or leaking.
- Intake system leak.
- Loose wires or connections that intermittently ground ignition kill circuit.
- Quality of fuel (dirt, water, stale, mixture).
- Restricted fuel tank cap vent.

Engine Starts Hard

- Clogged fuel line or fuel filter.
- Engine overheated.
- Faulty ACR mechanism.
- Faulty or misadjusted choke or throttle controls.
- Faulty spark plug(s).
- Flywheel key sheared.
- Fuel pump malfunction-vacuum hose clogged or leaking.
- Interlock switch is engaged or faulty.
- Loose wires or connections that intermittently ground ignition kill circuit.
- Low compression.
- Quality of fuel (dirt, water, stale, mixture).
- Weak spark.

Engine Will Not Crank

- Battery is discharged.
- Faulty electric starter or solenoid.
- Faulty key switch or ignition switch.
- Interlock switch is engaged or faulty.
- Loose wires or connections that intermittently ground ignition kill circuit.
- Pawls not engaging in drive cup.
- Seized internal engine components.

Engine Runs But Misses

- Carburetor adjusted incorrectly.
- Engine overheated.
- Faulty spark plug(s).
- Ignition module(s) faulty or improperly gapped.
- Incorrect crankshaft position sensor air gap.
- Interlock switch is engaged or faulty.
- Loose wires or connections that intermittently ground ignition kill circuit.
- Quality of fuel (dirt, water, stale, mixture).
- Spark plug lead(s) disconnected.
- Spark plug lead boot loose on plug.
- Spark plug lead loose.

Engine Will Not Idle

- Engine overheated.
- Faulty spark plug(s).
- Idle fuel adjusting needle(s) improperly set.
- Idle speed adjusting screw improperly set.
- Inadequate fuel supply.
- Low compression.
- Quality of fuel (dirt, water, stale, mixture).
- Restricted fuel tank cap vent.

Engine Overheats

- Cooling fan broken.
- Excessive engine load.
- Fan belt failed/off.
- Faulty carburetor.
- High crankcase oil level.
- Lean fuel mixture.
- Low cooling system fluid level.
- Low crankcase oil level.
- Radiator, and/or cooling system components clogged, restricted, or leaking.
- Water pump belt failed/broken.
- Water pump malfunction.

Engine Knocks

- Excessive engine load.
- Hydraulic lifter malfunction.
- Incorrect oil viscosity/type.
- Internal wear or damage.
- Low crankcase oil level.
- Quality of fuel (dirt, water, stale, mixture).

Troubleshooting

Engine Loses Power

- Dirty air cleaner element.
- Engine overheated.
- Excessive engine load.
- Restricted exhaust.
- Faulty spark plug(s).
- High crankcase oil level.
- Incorrect governor setting.
- Low battery.
- Low compression.
- Low crankcase oil level.
- Quality of fuel (dirt, water, stale, mixture).

Engine Uses Excessive Amount of Oil

- Loose or improperly torqued fasteners.
- Blown head gasket/overheated.
- Breather reed broken.
- Clogged, broken, or inoperative crankcase breather.
- Crankcase overfilled.
- Incorrect oil viscosity/type.
- Worn cylinder bore.
- Worn or broken piston rings.
- Worn valve stems/valve guides.

Oil Leaks from Oil Seals, Gaskets

- Breather reed broken.
- Clogged, broken, or inoperative crankcase breather.
- Loose or improperly torqued fasteners.
- Piston blow by, or leaky valves.
- Restricted exhaust.

EXTERNAL ENGINE INSPECTION

NOTE: It is good practice to drain oil at a location away from workbench. Be sure to allow ample time for complete drainage.

Before cleaning or disassembling engine, make a thorough inspection of its external appearance and condition. This inspection can give clues to what might be found inside engines (and cause) when it is disassembled.

- Check for buildup of dirt and debris on crankcase, cooling fins, grass screen, and other external surfaces. Dirt or debris on these areas can cause overheating.
- Check for obvious fuel and oil leaks, and damaged components. Excessive oil leakage can indicate a clogged or inoperative breather, worn or damaged seals or gaskets, or loose fasteners.
- Check air cleaner cover and base for damage or indications of improper fit and seal.
- Check air cleaner element. Look for holes, tears, cracked or damaged sealing surfaces, or other damage that could allow unfiltered air into engine. A dirty or clogged element could indicate insufficient or improper maintenance.
- Check throttle body throat for dirt. Dirt in throat is further indication that air cleaner was not functioning properly.
- Check if oil level is within operating range on dipstick. If it is above, sniff for gasoline odor.
- Check condition of oil. Drain oil into a container; it should flow freely. Check for metal chips and other foreign particles.

Sludge is a natural by-product of combustion; a small accumulation is normal. Excessive sludge formation could indicate over rich fuel settings, weak ignition, overextended oil change interval or wrong weight or type of oil was used.

CLEANING ENGINE

	⚠ WARNING
	Cleaning Solvents can cause severe injury or death. Use only in well ventilated areas away from ignition sources.
Carburetor cleaners and solvents are extremely flammable. Follow cleaner manufacturer's warnings and instructions on its proper and safe use. Never use gasoline as a cleaning agent.	

After inspecting external condition of engine, clean engine thoroughly before disassembly. Clean individual components as engine is disassembled. Only clean parts can be accurately inspected and gauged for wear or damage. There are many commercially available cleaners that will quickly remove grease, oil, and grime from engine parts. When such a cleaner is used, follow manufacturer's instructions and safety precautions carefully.

Make sure all traces of cleaner are removed before engine is reassembled and placed into operation. Even small amounts of these cleaners can quickly break down lubricating properties of engine oil.

CRANKCASE VACUUM TEST

	⚠ WARNING
	Carbon Monoxide can cause severe nausea, fainting or death. Take precautions against exposure to carbon monoxide (CO) emissions. Only operate an engine in well ventilated areas.
Engine exhaust gases contain poisonous carbon monoxide. Carbon monoxide is odorless, colorless, and can cause death if inhaled.	

	⚠ WARNING
	Rotating Parts can cause severe injury. Stay away while engine is in operation.
Keep hands, feet, hair, and clothing away from all moving parts to prevent injury. Never operate engine with covers, shrouds, or guards removed.	

A partial vacuum should be present in crankcase when engine is operating. Pressure in crankcase (normally caused by a clogged or improperly assembled breather) can cause oil to be forced out at oil seals, gaskets, or other available spots.

Crankcase vacuum is best measured with either a water manometer or a vacuum gauge (inches of water gauge only). Complete instructions are provided in kits.

To test crankcase vacuum with manometer:

1. Insert rubber stopper into oil fill hole. Be sure pinch clamp is installed on hose and use tapered adapters to connect hose between stopper and one manometer tube. Leave other tube open to atmosphere. Check that water level in manometer is at 0 line. Make sure pinch clamp is closed.
2. Start engine and run no-load high speed.
3. Open clamp and note water level in tube.
Level in engine side should be a minimum of 10.2 cm (4 in.) above level in open side.
If level in engine side is less than specified (low/no vacuum), or level in engine side is lower than level in open side (pressure), check for conditions in table below.
4. Close pinch clamp before stopping engine.

To test crankcase vacuum with vacuum/pressure gauge (inches of water gauge only):

1. Remove dipstick or oil fill plug/cap.
2. Install adapter into oil fill/dipstick tube opening, upside down over end of a small diameter dipstick tube, or directly into engine if a tube is not used. Insert barbed gauge fitting into hole in stopper.
3. Run engine and observe gauge reading.
Analog tester—needle movement to left of 0 is a vacuum, and movement to right indicates a pressure.
Digital tester—depress test button on top of tester.
Crankcase vacuum should be a minimum of 10.2 cm (4 in.) of water. If reading is below specification, or if pressure is present, check table below for possible causes and conclusions.

Condition	Conclusion
Crankcase breather clogged or inoperative.	NOTE: If breather is integral part of valve cover and cannot be serviced separately, replace valve cover and recheck pressure. Disassemble breather, clean parts thoroughly, check sealing surfaces for flatness, reassemble, and recheck pressure.
Seals and/or gaskets leaking. Loose or improperly torque fasteners.	Replace all worn or damaged seals and gaskets. Make sure all fasteners are tightened securely. Use appropriate torque values and sequences when necessary.
Piston blow by or leaky valves (confirm by inspecting components).	Recondition piston, rings, cylinder bore, valves and valves guides.
Restricted exhaust.	Check exhaust screen/spark arrestor (if equipped). Clean or replace as needed. Repair or replace any other damaged/restricted muffler or exhaust system parts.

Troubleshooting

COMPRESSION TEST

A compression test is best performed on a warm engine. Clean any dirt or debris away from base of spark plug(s) before removing them. Be sure battery is fully charged, unplug ECU, and throttle is wide open during test. Compression should be at least 160 psi and should not vary more than 15% between cylinders.

Some models may be equipped with an automatic compression release (ACR) mechanism. It is difficult to obtain an accurate compression reading because of ACR mechanism. As an alternative, use cylinder leakdown test described below.

CYLINDER LEAKDOWN TEST

A cylinder leakdown test can be a valuable alternative to a compression test. By pressurizing combustion chamber from an external air source you can determine if valves or rings are leaking, and how badly.

Cylinder leakdown tester is a relatively simple, inexpensive leakdown tester for small engines. This tester includes a quick-connect for attaching adapter hose and a holding tool.

Dual Gauge Test Procedure

1. Run engine until oil temperature reaches and maintains 150°F (66°C) or more for a minimum of 5 minutes. Ideally, engine should be run under normal load conditions.
2. Remove spark plug(s) and air filter from engine.
3. Rotate crankshaft until piston (of cylinder being tested) is at top dead center (TDC) of compression stroke. Hold engine in this position while testing. Holding tool from kit can be used if PTO end of crankshaft is accessible. Lock holding tool onto crankshaft. Install a 3/8 in. breaker bar into hole/slot of holding tool, so it is perpendicular to both holding tool and crankshaft PTO.

If flywheel end is more accessible, use a breaker bar and socket on flywheel nut/screw to hold it in position. An assistant may be needed to hold breaker bar during testing. If engine is mounted in a piece of equipment, it may be possible to hold it by clamping or wedging a driven component. Just be certain engine cannot rotate off TDC in either direction.

4. Connect an air source (at least 100 PSI) to tool.
5. Turn regulator knob clockwise (increase direction). Confirm both gauges read approximately the same air pressure from 0 to 80 PSI. Note any discrepancies between gauges for leakage calculation. Release pressure by turning regulator knob completely counterclockwise before proceeding.
6. Install adapter hose into spark plug hole of cylinder being tested. Use 12 mm x 14 mm adapter if required.
7. Firmly hold engine at TDC. Connect other end of adapter hose to tool quick connect. Turn regulator knob clockwise (increase direction) until left gauge needle reads 20 PSI.

NOTE: When piston is at TDC, little to no holding force should be required when air pressure is applied to cylinder. If excess holding force is required, this indicates piston is not at TDC. Readjust as necessary before proceeding.

8. Slowly turn regulator knob clockwise until left hand gauge maintains selected test pressure (see chart below).

Left Gauge Regulated Pressure Selection
80 PSI Recommended for engines over 200 cc or those exhibiting high leakage at 35 PSI setting.
35 PSI Recommended for single cylinder walk-behind push mower applications.

9. Compare right gauge reading to Test Pressure Chart on next page to identify percentage of leakage. Also refer to Leakdown Test Results chart on next page for colors, conditions, and action required.
10. For engines exhibiting leakage in yellow or red zone, repeat test procedure. Operate engine under normal load conditions prior to test. Confirm piston is at TDC during test.

NOTE: To prevent damage to gauge assembly, always turn pressure regulator knob to zero (counterclockwise) after each test.

Test Pressure Chart for Dual Gauge Tool

Left Gauge Regulated Pressure Selection	Right Gauge Reading in PSI										
80 PSI Recommended for engines over 200 cc or those exhibiting high leakage at 35 PSI setting.	80	72	64	56	48	40	32	24	16	8	0
35 PSI Recommended for single cylinder walk-behind push mower applications.	35	31.5	28	24.5	21	17.5	14	10.5	7	3.5	0
Percentage of leakage	0%	10%	20%	30%	40%	50%	60%	70%	80%	90%	100%
	Green Zone				Yellow Zone			Red Zone			

Leakdown Test Results

Test Result	Condition	Action
Gauge reading in low (green) zone.	Piston rings and cylinder in good condition.	No further action required.
Gauge reading in moderate (yellow) zone.	Air escaping from crankcase breather and/or dipstick tube.	Some wear present causing leakage from combustion chamber to crankcase. Repair not required at this time if breather system is functioning normally.
	Air escaping from exhaust.	Exhaust valve leakage present, possibly due to carbon deposits. Repair not required. Carbon cleaning could be performed to reduce leakage.
	Air escaping from intake.	Intake valve leakage present, possibly due to carbon deposits. Repair not required. Carbon cleaning could be performed to reduce leakage.
Gauge reading in high (red) zone. Confirm consecutive leakdown test has been performed AFTER engine has been operated under normal load conditions.	Air escaping from crankcase breather and/or dipstick tube.	Excess wear present causing leakage from combustion chamber to crankcase. Breather system will not function normally and will fail crankcase vacuum test if this condition is truly present. Engine disassembly and analysis required to determine root cause and correction.
	Air escaping from exhaust.	Excess exhaust valve leakage present, possibly due to carbon deposits and/or valve to seat sealing issues. Carbon cleaning may reduce leakage. Valve grind and/or component replacement may be necessary. Excess oil consumption and/or excess heat is a suspect cause and must be resolved to prevent reoccurrence.
	Air escaping from intake.	Excess intake valve leakage present, possibly due to carbon deposits and/or valve to seat sealing issues. Carbon cleaning may reduce leakage. Valve grind and/or component replacement may be necessary. Excess oil consumption through intake valve and/or excess heat is a suspect cause and must be resolved to prevent reoccurrence. Inspect breather system components and intake valve stem sealing.

Air Cleaner/Intake

AIR CLEANER

These systems are CARB/EPA certified and components should not be altered or modified in any way.

Low-Profile Air Cleaner Components

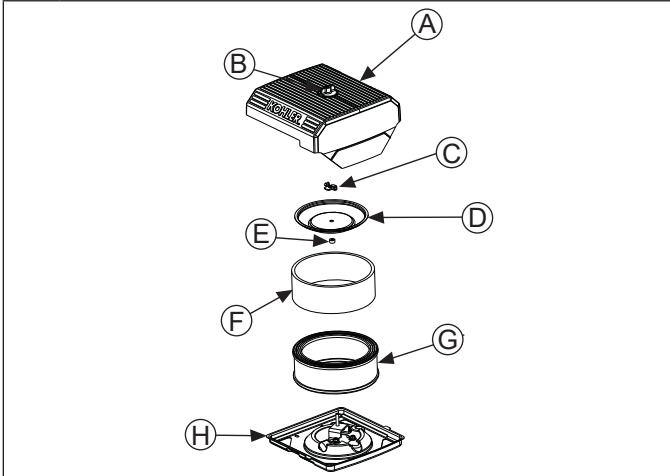

A	Air Cleaner Cover	B	Air Cleaner Knob
C	Wing Nut	D	Element Cover
E	Rubber Seal	F	Precleaner
G	Paper Element	H	Air Cleaner Base

Heavy-Duty Air Cleaner Components

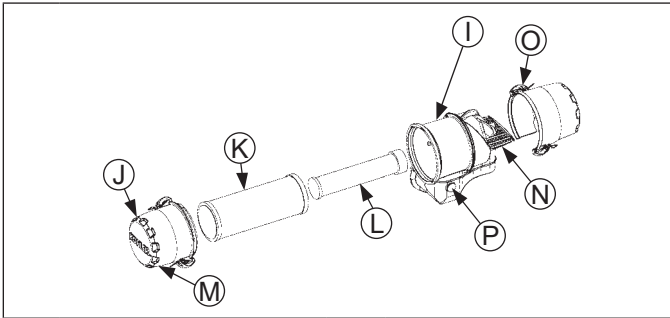

I	Air Cleaner Housing	J	End Cap
K	Element	L	Inner Element
M	Ejector Area	N	Inlet Screen
O	Retaining Clip	P	Filter Minder

NOTE: Operating engine with loose or damaged air cleaner components could cause premature wear and failure. Replace all bent or damaged components.

NOTE: Paper element cannot be blown out with compressed air.

Low-Profile

Loosen knob and remove air cleaner cover.

Precleaner

1. Remove precleaner from paper element.
2. Replace or wash precleaner in warm water with detergent. Rinse and allow to air dry.
3. Saturate precleaner with new engine oil; squeeze out excess oil.
4. Reinstall precleaner over paper element.

Paper Element

1. Clean area around element. Remove wing nut, element cover, and paper element with precleaner.
2. Separate precleaner from element; service precleaner and replace paper element.
3. Check condition of rubber seal and replace if necessary.
4. Install new paper element on base; install precleaner over paper element; reinstall element cover and secure with wing nut.

Reinstall air cleaner cover and secure with knob.

Heavy-Duty

1. Unhook retaining clips and remove end cap(s).
2. Check and clean inlet screen (if equipped).
3. Pull air cleaner element out of housing and replace. Check condition of inner element; replace when dirty.
4. Check all parts for wear, cracks, or damage, and that ejector area is clean.
5. Install new element(s).
6. Reinstall end cap(s) with dust ejector valve/screen down; secure with retaining clips.

BREATHER TUBE

Ensure sure both ends of breather tube are properly connected.

AIR COOLING

	<p>! WARNING</p> <p>Hot Parts can cause severe burns. Do not touch engine while operating or just after stopping.</p>
	<p>Never operate engine with heat shields or guards removed.</p>

Proper cooling is essential. To prevent over heating, clean screens, cooling fins, and other external surfaces of engine. Avoid spraying water at wiring harness or any electrical components. Refer to Maintenance Schedule.

	⚠ WARNING
	<p>Explosive Fuel can cause fires and severe burns.</p> <p>If a gaseous odor is detected, ventilate area and contact an authorized service technician.</p>
<p>Propane is extremely flammable and is heavier than air and tends to settle in low areas where a spark or flame could ignite gas. Do not start or operate this engine in a poorly ventilated area where leaking gas could accumulate and endanger safety of persons in area.</p> <p>To ensure personal safety, installation and repair of propane fuel supply systems must be performed only by qualified propane system technicians. Improperly installed and maintained propane equipment could cause fuel supply system or other components to malfunction, causing gas leaks.</p> <p>Observe federal, state and local laws governing propane fuel, storage, and systems.</p>	

Typical propane electronic fuel injection (EFI) system and related components include:

- Vaporizer/regulator.
- Fuel filter.
- High pressure fuel line.
- Fuel line(s).
- Gaseous propane fuel injectors.
- Throttle body/intake manifold.
- Electronic control unit (ECU).
- Ignition coils.
- Engine (oil) temperature sensor.
- Throttle position sensor (TPS). Earlier engines have a contacting (brushes) TPS. Later engines have a contactless (magnetic) TPS.
- Crankshaft position sensor.
- Oxygen sensor.
- Earlier engines have a separate manifold absolute pressure sensor (MAP) and an intake air temperature (IAT) sensor (located in throttle body).
- Later engines have a combined temperature/manifold absolute pressure (TMAP) sensor.
- Wire harness assembly & affiliated wiring.
- Malfunction indicator light (MIL) - optional.

FUEL RECOMMENDATIONS

Refer to Maintenance.

FUEL LINE

High pressure fuel line meeting a minimum of SAE R7 standard must be installed on Rehlko engines equipped with propane EFI system (from vaporizer/regulator to injectors).

OPERATION

NOTE: When performing voltage or continuity tests, avoid putting excessive pressure on or against connector pins. Flat pin probes are recommended for testing to avoid spreading or bending terminals.

EFI system is designed to provide peak engine performance with optimum fuel efficiency and lowest possible emissions. Ignition and injection functions are electronically controlled, monitored and continually corrected during operation to maintain ideal air/fuel ratio.

Central component of system is Electronic Control Unit (ECU) which manages system operation, determining best combination of fuel mixture and ignition timing for current operating conditions.

Fuel is delivered from tank to integrated lock-off valve at tank pressure. Fuel travels to vaporizer/regulator which reduces pressure to 24-26 psi (typical). Fuel then passes through a fine high pressure filter, is delivered from vaporizer/regulator through high pressure fuel line into injectors, which inject fuel into intake ports. ECU controls amount of fuel by varying length of time that injectors are on. This can range from 2 to over 12 milliseconds depending on fuel requirements. Controlled injection of fuel occurs every other crankshaft revolution, or once for each 4-stroke cycle. When intake valve opens, air/fuel mixture is drawn into combustion chamber, compressed, ignited, and burned.

ECU controls amount of fuel being injected and ignition timing by monitoring primary sensor signals for engine temperature, speed (RPM), and throttle position (load). These primary signals are compared to preprogrammed maps in ECU computer chip, and ECU adjusts fuel delivery to match mapped values. After engine reaches operating temperature, an exhaust gas oxygen sensor provides feedback to ECU based upon amount of unused oxygen in exhaust, indicating whether fuel mixture being delivered is rich or lean. Based upon this feedback, ECU further adjusts fuel input to re-establish ideal air/fuel ratio. This operating mode is referred to as closed loop operation. EFI system operates closed loop when all three of following conditions are met:

- Oil temperature is greater than 50-60°C (122-140°F).
- Oxygen sensor has warmed sufficiently to provide a signal (minimum 400°C, 752°F).
- Engine operation is at a steady state (not starting, warming up, accelerating, etc.).

During closed loop operation ECU has ability to readjust temporary and learned adaptive controls, providing compensation for changes in overall engine condition and operating environment, so it will be able to maintain ideal air/fuel ratio. This system requires a minimum engine oil temperature greater than 60-70°C (140-158°F) to properly adapt. These adaptive values are maintained as long as ECU is not reset.

During certain operating periods such as cold starts, warm up, acceleration, high load, etc., a richer air/fuel ratio is required and system operates in an open loop mode. In open loop operation oxygen sensor output is used to ensure engine is running rich, and controlling adjustments are based on primary sensor signals and programmed maps only. This system operates open loop whenever three conditions for closed loop operation (above) are not being met.

ECU is brain or central processing computer of entire EFI system. During operation, sensors continuously gather data which is relayed through wiring harness to input circuits within ECU. Signals to ECU include: ignition (on/off), crankshaft position and speed (RPM), throttle position, oil temperature, intake air temperature, exhaust oxygen levels, manifold absolute pressure, and battery voltage.

Propane EFI System

ECU compares input signals to programmed maps in its memory to determine appropriate fuel and spark requirements for immediate operating conditions. ECU then sends output signals to set injector duration and ignition timing.

ECU continually performs a diagnostic check of itself, each of sensors, and system performance. If a fault is detected, ECU can turn on a Malfunction Indicator Light (MIL) (if equipped) on equipment control panel, store fault code in its fault memory, and go into a default operating mode. Depending on significance or severity of fault, normal operation may continue. A technician can access stored fault code using a blink code diagnosis flashed out through MIL. An optional computer software diagnostic program is also available, see Tools and Aids.

ECU requires a minimum of 6.0 volts to operate.

To prevent engine over-speed and possible failure, a rev-limiting feature is programmed into ECU. If maximum RPM limit (4500) is exceeded, ECU suppresses injection signals, cutting off fuel flow. This process repeats itself in rapid succession, limiting operation to preset maximum.

Wiring harness used in EFI system connects electrical components, providing current and ground paths for system to operate. All input and output signaling occurs through two special all weather connectors that attach and lock to ECU. Connectors are Black and Grey and keyed differently to prevent being attached to ECU incorrectly.

Condition of wiring, connectors, and terminal connections is essential to system function and performance. Corrosion, moisture, and poor connections are as likely cause of operating problems and system errors as an actual component. Refer to Electrical System for additional information.

EFI system is a 12 VDC negative ground system, designed to operate down to a minimum of 6.0 volts. If system voltage drops below this level, operation of voltage sensitive components such as ECU, lock-off valve, ignition coils, and injectors will be intermittent or disrupted, causing erratic operation or hard starting. A fully charged, 12 volt battery with a minimum of 350 cold cranking amps is important in maintaining steady and reliable system operation. Battery condition and state of charge should always be checked first when troubleshooting an operational problem.

Keep in mind that EFI-related problems are often caused by wiring harness or connections. Even small amounts of corrosion or oxidation on terminals can interfere with milliamp currents used in system operation.

Cleaning connectors and grounds will solve problems in many cases. In an emergency situation, simply disconnecting and reconnecting connectors may clean up contacts enough to restore operation, at least temporarily.

If a fault code indicates a problem with an electrical component, disconnect ECU connector and test for continuity between component connector terminals and corresponding terminals in ECU connector using an ohmmeter. Little or no resistance should be measured, indicating that wiring of that particular circuit is OK.

Crankshaft Position Sensor Bracket

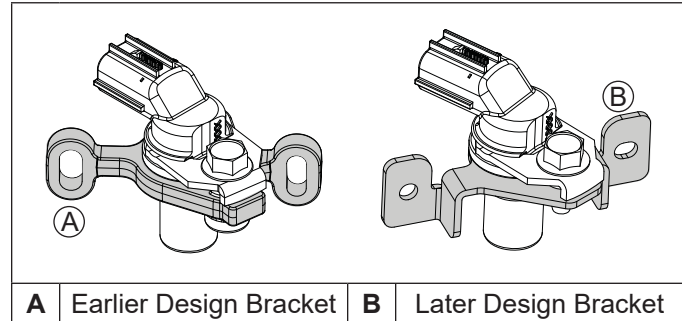

Crankshaft position sensor is essential to engine operation; constantly monitoring rotation and speed (RPM) of crankshaft. There are 23 consecutive teeth cast into flywheel. One tooth is missing and is used to reference crankshaft position for ECU. Inductive crankshaft position sensor with earlier design bracket is mounted 0.20-0.70 mm (0.008-0.027 in.) from flywheel. Later design bracket requires no adjustment.

During rotation, an AC voltage pulse is created within sensor for each passing tooth. ECU calculates engine speed from time interval between consecutive pulses. gap from missing tooth creates an interrupted input signal, corresponding to specific crankshaft position near BDC for cylinder #1. This signal serves as a reference for control of ignition timing by ECU. Synchronization of inductive speed pickup and crankshaft position takes place during first two revolutions each time engine is started. Sensor must be properly connected at all times. If sensor becomes disconnected for any reason, engine will quit running.

Throttle position sensor (TPS) is used to indicate throttle plate angle to ECU. Since throttle (by way of governor) reacts to engine load, angle of throttle plate is directly related to load on engine.

Mounted on throttle body and operated directly off end of throttle shaft, TPS works as a potentiometer, varying voltage signal to ECU in direct correlation to angle of throttle plate. This signal, along with other sensor signals, is processed by ECU and compared to internal preprogrammed maps to determine required fuel and ignition settings for amount of load.

Correct position of TPS is established and set at factory. Do not loosen TPS or alter mounting position unless absolutely required by fault code diagnosis. If TPS is loosened or repositioned, appropriate TPS Learn Procedure must be performed to re-establish baseline relationship between ECU and TPS.

Engine (oil) temperature sensor is used by system to help determine fuel requirements for starting (a cold engine needs more fuel than one at or near operating temperature).

Mounted in breather cover, it has a temperature-sensitive resistor that extends into oil flow. Resistance changes with oil temperature, altering voltage sent to ECU. Using a table stored in its memory, ECU correlates voltage drop to a specific temperature. Using fuel delivery maps, ECU then knows how much fuel is required for starting at that temperature.

Earlier engines have a separate intake air temperature (IAT) sensor (located in throttle body) and a manifold absolute pressure (MAP) sensor. Later engines have a combined temperature/manifold absolute pressure (TMAP) sensor.

Intake Air Temperature (IAT) sensor is a thermally sensitive resistor that exhibits a change in electrical resistance with a change in its temperature. When sensor is cold, resistance of sensor is high. As sensor warms up, resistance drops and voltage signal increases. From voltage signal, ECU can determine temperature of intake air.

Purpose of an air temperature sensor is to help ECU calculate air density. Higher air temperature less dense air becomes. As air becomes less dense ECU knows that it needs to lessen fuel flow to achieve correct air/fuel ratio. If fuel ratio was not changed engine would become rich, possibly losing power and consuming more fuel.

Manifold absolute pressure (MAP) sensor provides immediate manifold pressure information to ECU. MAP measures difference in pressure between outside atmosphere and vacuum level inside intake manifold and monitors pressure in manifold as primary means of detecting load. Data is used to calculate air density and determine engine's mass air flow rate, which in turn determines required ideal fueling. MAP also stores instant barometric pressure reading when key is turned ON.

Later engines have a Temperature/Manifold Absolute Pressure (TMAP) sensor. This is an integrated sensor that checks both intake air temperature and manifold absolute pressure. This combined sensor is located in intake manifold.

Oxygen sensor functions like a small battery, generating a voltage signal to ECU based upon difference in oxygen content between exhaust gas and ambient air.

Tip of sensor, protruding into exhaust gas, is hollow. Outer portion of tip is surrounded by exhaust gas, with inner portion exposed to ambient air. When oxygen concentration on one side of tip is different than that of other side, a voltage signal up to 1.0 volt is generated and sent to ECU. Voltage signal tells ECU if engine is straying from ideal fuel mixture, and ECU then adjusts injector pulse accordingly.

Oxygen sensor functions after being heated to a minimum of 400°C (752°F). A heater inside sensor heats electrode to optimum temperature in about 10 seconds. Oxygen sensor receives ground through wire, eliminating need for proper grounding through muffler. If problems indicate a bad oxygen sensor, check all connections and wire harness. Oxygen sensor can also be contaminated by leaded fuel, certain RTV and/or other silicone compounds, fuel injector cleaners, etc. Use only those products indicated as O2 Sensor Safe.

Fuel injectors mount into intake manifold, and high pressure fuel line attaches to them at top end. Replaceable O-rings on both ends of injector prevent external fuel leakage and also insulate it from heat and vibration. A special clip connects each injector to high pressure fuel line and holds it in place. O-rings and retaining clip must be replaced any time fuel injector is separated from its normal mounting position.

When key switch is on, lock-off valve will open briefly and allow fuel into system at 24-26 psi, and voltage is present at injector. At proper instant, ECU completes ground circuit, energizing injector. Valve needle in injector is opened electromagnetically, and pressure in high pressure fuel line forces fuel down through inside. Director plate at tip of injector contains a series of calibrated openings which directs fuel into manifold.

Injectors have sequential fueling that open and close once every other crankshaft revolution. Amount of fuel injected is controlled by ECU and determined by length of time valve needle is held open, also referred to as injection duration or pulse width. Time injector is open (milliseconds) may vary in duration depending on speed and load requirements of engine.

A high-voltage, solid-state, battery ignition system is used with EFI system. ECU controls ignition output and timing through transistorized control of primary current delivered to coils. Based on input from crankshaft position sensor, ECU determines correct firing point for speed at which engine is running. At proper instant, it interrupts flow of primary current in coil, causing electromagnetic flux field to collapse. Flux collapse induces an instantaneous high voltage in coil secondary which is strong enough to bridge gap on spark plug. Each coil fires every other revolution.

EFI engines are equipped with either a 20 or 25 amp charging system to accommodate combined electrical demands of ignition system and specific application. Charging system troubleshooting information is provided in Electrical System.

When key switch is turned ON and all safety switch requirements are met, ECU activates lock-off valve for about six seconds, which pressurizes system for start-up. If key switch is not promptly turned to start position, engine fails to start, or engine is stopped with key switch ON (as in case of an accident), ECU switches off lock-off valve preventing continued delivery of fuel. In this situation, MIL will go on, but it will go back off after 4 cranking revolutions if system function is OK. Once engine is running, lock-off valve remains on.

There are two filters in system, one on inlet of vaporizer/regulator will be a 30-micron button filter, and one after will be a special metal 10-micron filter. Be sure to use metal propane 10-micron filter for replacement.

High pressure fuel line is an assembly of hoses, injector caps and a fuel connector to vaporizer/regulator. High pressure fuel line feeds fuel to top of injectors through injector caps. Caps are fastened to intake manifold and injectors are locked into place. A small retaining clip provides a secondary lock.

Propane EFI System

High pressure fuel line is serviced as a complete assembly to prevent tampering and safety hazards. Components are not individually serviceable.

Vacuum hose connects vaporizer/regulator to throttle body, compensating regulated pressure for air cleaner condition.

EFI engines have no carburetor, so throttle function (regulate incoming combustion airflow) is achieved with a throttle valve in a separate throttle body attached to intake manifold. Throttle body/intake manifold provides mounting for fuel injectors, throttle position sensor, MAP sensor, intake air temperature sensor, high pressure fuel line, idle speed screw, and air cleaner assembly.

Idle speed is only adjustment that may be performed on EFI system. Standard idle speed setting for EFI engines is 1500 RPM, but certain applications might require a different setting. Check equipment manufacturer's recommendation.

For starting and warm up, ECU will adjust fuel and ignition timing, based upon ambient temperature, engine temperature, and loads present. In cold conditions, idle speed will probably be different than normal for a few moments. Under other conditions, idle speed may actually start lower than normal, but gradually increase to established setting as operation continues. Do not attempt to circumvent this warm up period, or readjust idle speed during this time. Engine must be completely warmed up, in closed loop operating mode for accurate idle adjustment.

IMPORTANT NOTES!

- Cleanliness is essential and must be maintained at all times when servicing or working on EFI system. Dirt, even in small quantities, can cause significant problems.
- Clean any joint or fitting with parts cleaning solvent before opening to prevent dirt from entering system.
- Always depressurize fuel system before disconnecting or servicing any fuel system components. Shut off tank valve. If possible, run engine in a well-ventilated area until fuel system is empty and engine stops. If unable to run engine, work in a well-ventilated area and carefully loosen inlet fuel fitting on vaporizer/regulator, slowly venting off fuel from line. When fuel is dispensed, retighten fitting and remove quick connect fitting to allow fuel to escape from line.
- Never attempt to service any fuel system component while engine is running or ignition switch is ON.
- Do not use compressed air if system is open. Cover any parts removed and wrap any open joints with plastic if they will remain open for any length of time. New parts should be removed from their protective packaging just prior to installation.
- Avoid direct water or spray contact with system components.
- Do not disconnect or reconnect ECU wiring harness connector or any individual components with ignition on. This can send a damaging voltage spike through ECU.
- Do not allow battery cables to touch opposing terminals. When connecting battery cables attach positive (+) cable to positive (+) battery terminal first, followed by negative (-) cable to negative (-) battery terminal.
- Never start engine when cables are loose or poorly connected to battery terminals.
- Never disconnect battery while engine is running.
- Never use a quick battery charger to start engine.
- Do not charge battery with key switch ON.
- Always disconnect negative (-) battery cable before charging battery, and also unplug harness from ECU before performing any welding on equipment.

ELECTRICAL COMPONENTS

Electronic Control Unit (ECU)

Pinout of ECU

Black Connector Side	
Pin #	Function
1	Ignition Coil #1 Ground
2	Battery Ground
3	Diagnostic Communication Line
4	Speed Sensor input
5	Fuel Injector Output #1 Ground
6	Fuel Injector Output #2 Ground
7	Oxygen Sensor Heater
8	Intake Air Temperature (IAT) sensor or TMAP sensor input
9	Fuel Lock-Off Ground
10	Ground for TPS, IAT and MAP sensors or TMAP sensor, O2 and Oil sensors
11	MAP sensor or TMAP sensor input
12	Throttle Position Sensor (TPS) input
13	Speed Sensor Ground
14	Oil Temperature Sensor input
15	Ignition Switch (Switched +12V)
16	Power for TPS sensor, MAP sensor or TMAP sensor (+5V)
17	Oxygen Sensor (O2) input
18	Battery Power (Permanent +12V)

Grey Connector Side	
Pin #	Description
1	Not Used
2	Not Used
3	Malfunction Indicator Light (MIL) Ground
4	Not Used
5	Not Used
6	Not Used
7	Not Used
8	Not Used
9	Battery Ground
10	Ignition Coil #2 Ground
11	Not Used
12	Not Used
13	Not Used
14	Safety Switch Ground
15	Not Used
16	ECU
17	Fuel Lock-Off Control (+12V)
18	Not Used

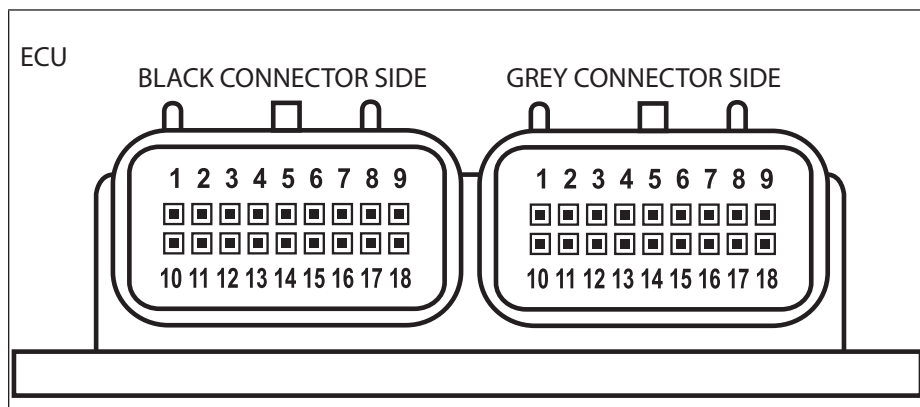

Pinout of ECU

Propane EFI System

Never attempt to disassemble ECU. It is sealed to prevent damage to internal components. Warranty is void if case is opened or tampered with in any way.

All operating and control functions within ECU are preset. No internal servicing or readjustment may be performed. If a problem is encountered, and you determine ECU to be faulty, contact your source of supply.

ECU pins are coated at factory with a thin layer of electrical grease to prevent fretting and corrosion. Do not attempt to remove grease from ECU pins.

Relationship between ECU and throttle position sensor (TPS) is very critical to proper system operation. If TPS or ECU is changed, or mounting position of TPS is altered, appropriate TPS Learn Procedure must be performed to restore synchronization.

Any service to ECU or TPS/Throttle Body (including idle speed increase over 300 RPM), should include ECU Reset.

This will clear all trouble codes, all closed loop learned offsets, all max values, and all timers besides permanent hour meter.

This system will NOT reset when battery is disconnected!

ECU Reset Procedure

1. Turn key/ignition OFF.
2. Install Red wire jumper from Rehlko EFI service kit on to service port (connect white wire to black wire in 4 way diagnostic port).
3. Turn key/ignition ON, then OFF and count 10 seconds.
4. Turn key/ignition ON, then OFF and count to 10 seconds a second time.
5. Remove Red wire jumper. Turn key/ignition ON, then OFF and count to 10 seconds a third time. ECU is reset.

A TPS Learn Procedure **must** be performed after ECU Reset.

TPS Learn Procedure

1. Turn idle screw clockwise one full turn prior to key/ignition ON after ECU Reset.
2. Start engine, run at low idle until engine is warm.
3. Idle speed must be above 1500 RPM. If below 1500 RPM, turn idle screw up to 1700 RPM and then shut down engine and perform ECU Reset again.
4. Adjust idle speed down to 1500 RPM. Allow engine to dwell at 1500 RPM for about 3 seconds.
5. After this, adjust idle speed to final specified speed setting.
6. Turn key/ignition OFF and count to 10 seconds.

Learn procedure is complete.

Wiring Harness

EFI Wiring Diagram 6-Terminal Connector (engines with separate MAP sensor and intake air temperature sensor)

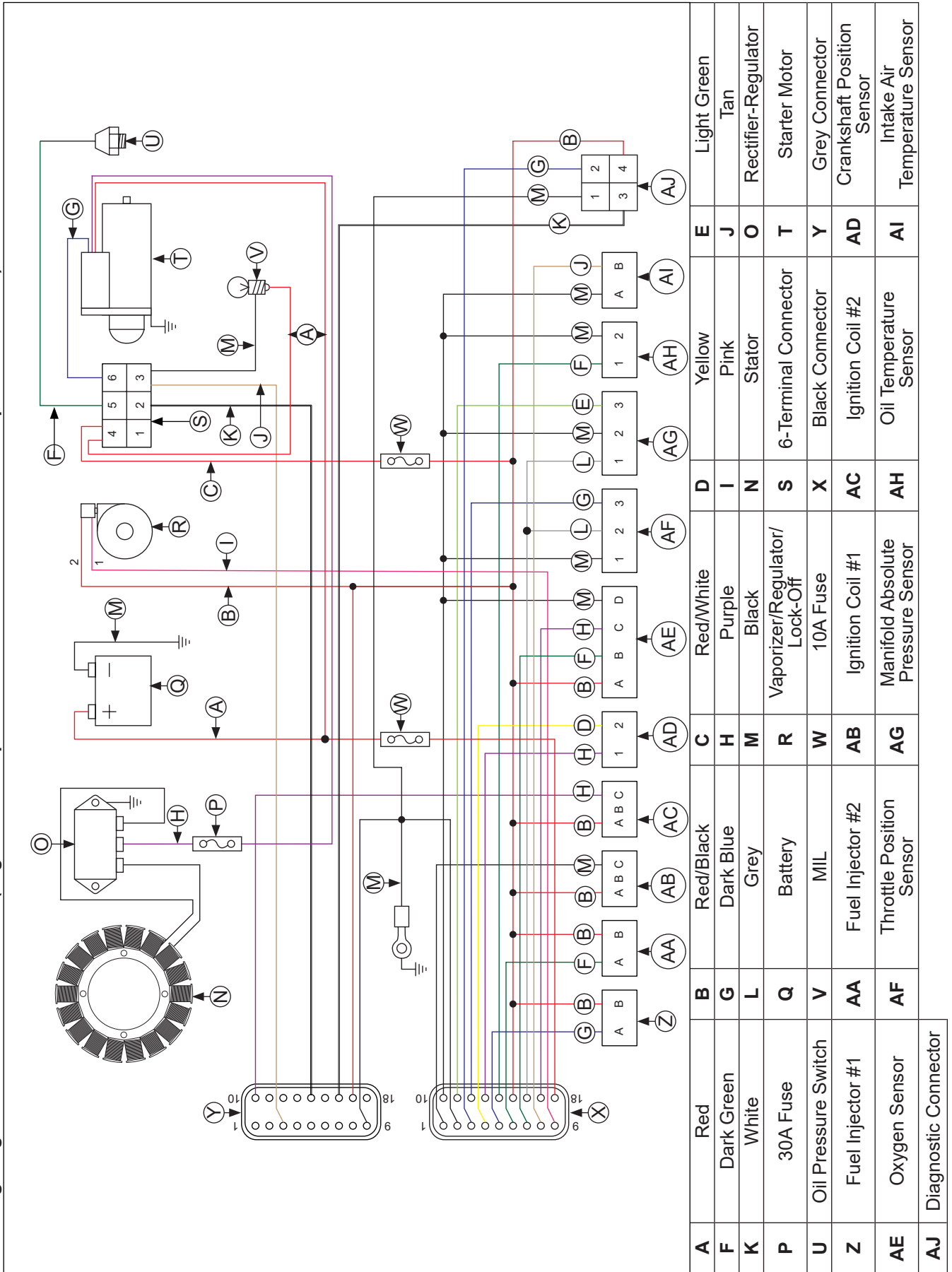

Propane EFI System

EFI Wiring Diagram 5-Terminal Connector and Optional Key Switch (engines with separate MAP sensor and intake air temperature sensor)

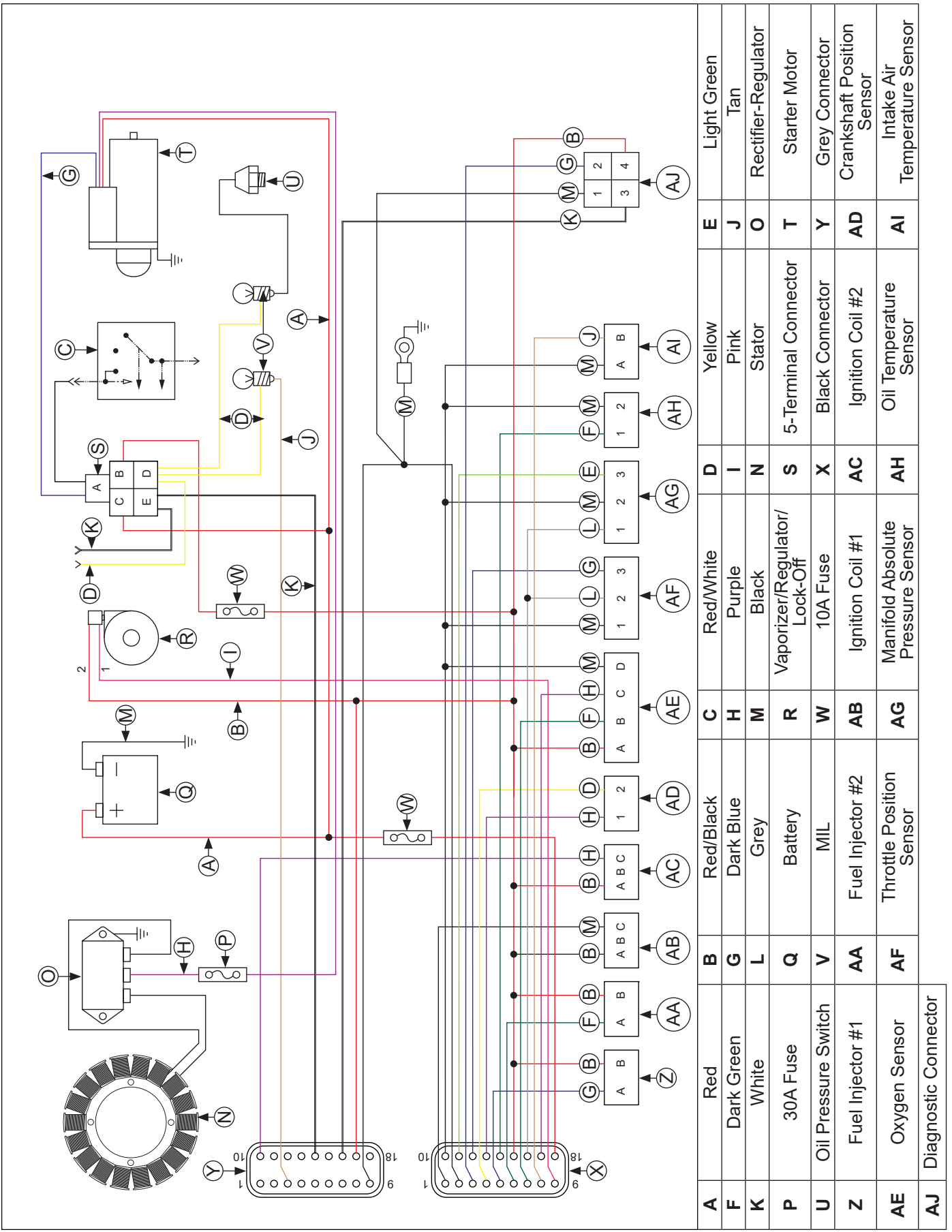

Propane EFI System

EFI Wiring Diagram 5-Terminal Connector and Optional Key Switch (engines with TMAP sensor)

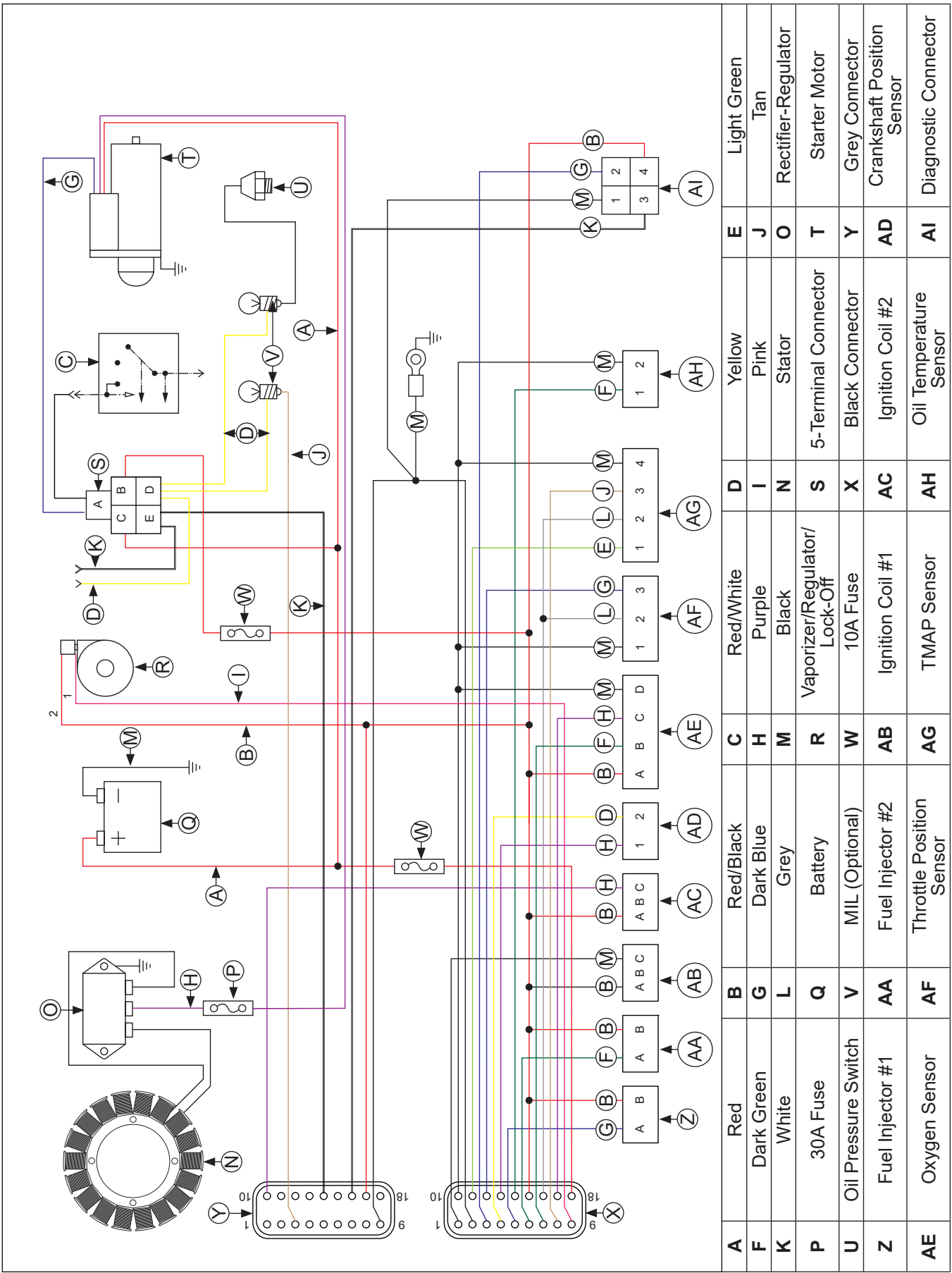

Crankshaft Position Sensor

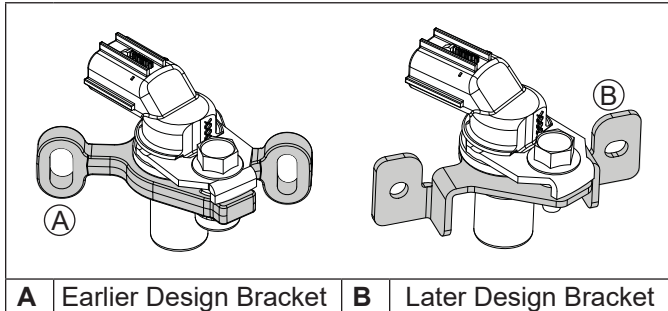

A sealed, non-serviceable assembly. If Fault Code diagnosis indicates a problem within this area, test and correct as follows.

- Check mounting and air gap of crankshaft position sensor.
Earlier design bracket has slots to set air gap of 0.20-0.70 mm (0.008-0.027 in.).
Later design bracket is not adjustable, but if gap is greater than 2.794 mm (0.110 in.) check bracket or sensor for damage.
- Inspect wiring and connections for damage or problems.
- Make sure engine has resistor type spark plugs.
- Disconnect Black connector from ECU.
- Connect an ohmmeter between #4 and #13 pin terminals. A resistance value of 325-395 Ω at room temperature (20°C, 68°F) should be obtained. If resistance is correct, check mounting, air gap, flywheel teeth (damage, run-out, etc.), and flywheel key.
- Disconnect crankshaft position sensor connector from wiring harness. Test resistance between terminals. A reading of 325-395 Ω should again be obtained.
 - If resistance is incorrect, remove screws securing sensor to mounting bracket and replace sensor.
 - If resistance in step 5 was incorrect, but resistance of sensor alone was correct, test wire harness circuits between sensor connector terminals and corresponding pin terminals (#4 and #13) in main connector. Correct any observed problem, reconnect sensor, and perform step 5 again.
- When fault is corrected and engine starts, clear fault codes following ECU Reset procedure.

Throttle Position Sensor (TPS)

Earlier engines were built with a contacting (brush) type TPS. Later engines are built with a contactless (magnet) type TPS. Both designs have same three wires attached; a 5 volt supply, a ground, and a signal wire. However, these designs are not interchangeable. Follow proper testing information based on sensor type.

Contacting (Brush) Type TPS Resistance Table

Throttle Position	Between Terminal	Resistance Value (Ω)	Continuity
Closed	A & C	1400-1800	Yes
Full with Stop Pin	A & C	3200-4100	Yes
Full without Stop Pin	A & C	4600-5200	Yes
Any	A & B	3000-7000	Yes

TPS is a sealed, non-serviceable assembly. If diagnosis indicates a bad sensor, complete replacement is necessary. If a blink code indicates a problem with TPS, it can be tested as follows:

- Counting number of turns, back out idle speed adjusting screw (counterclockwise) until throttle plates can be closed completely. Write this number down for reference later.
- Disconnect Black connector from ECU, but leave TPS mounted to throttle body.
- Use an ohmmeter and connect red (positive) ohmmeter lead to Black pin 12 terminal and black (negative) ohmmeter lead to Black pin 10 terminal to test.
 - Hold throttle closed and check resistance. It should be 1400-1800 Ω .
- Leave leads connected to pin terminals as described in step 3. Rotate throttle shaft slowly to full throttle position. Monitor dial during rotation for indication of any momentary short or open circuits. Note resistance at full throttle position. It should be 4600-5200 Ω without a stop pin, or 3200-4100 Ω with a stop pin.
- Disconnect main wiring harness connector from TPS, leaving TPS assembled to throttle body. Refer to Resistance Table and perform resistance checks indicated between terminals in TPS switch, with throttle in positions specified.
If resistance values in steps 3, 4, and 5 are within specifications, go to step 6.
If resistance values are not within specifications, or a momentary short or open circuit was detected during rotation (step 4), TPS needs to be replaced, go to step 7.
- Check TPS circuits (input, ground) between TPS plug and main harness connector for continuity, damage, etc. Input pin is 12 and ground is pin 10.
 - Repair or replace as required.
 - Turn idle speed screw back in to its original setting.
 - Reconnect connector plugs, start engine and retest system operation.

Propane EFI System

7. Remove two mounting screws from TPS. Save screws for reuse. Remove and discard faulty TPS. Install replacement TPS and secure with original mounting screws.
 - a. Reconnect Black and TPS connector plugs.
 - b. Perform TPS Learn Procedure integrating new sensor to ECU.

Contactless (Magnet) Type TPS

TPS is a sealed, non-serviceable assembly. If diagnosis indicates a bad sensor, complete replacement is necessary. Magnet that sensor detects is separate, and can be replaced or reused. If a blink code indicates a problem with TPS, it can be tested as follows:

Diagnostics of sensor: ECU will still have electrical faults captured in fault codes: P0122 & P0123. These electrical faults still have same meaning as with prior sensor, P0122 detecting low voltage, open circuit, and P0123 for high voltage conditions between ECU, wire harness, and sensor. Tip: when working with any electrical connection, remember to keep connections clean & dry. This is best accomplished by cleaning connection thoroughly prior to disassembly. Contaminated sensor connections can cause premature engine faults. Functionally testing sensor can no longer be done with simple resistance checks. If either of these two faults is present or a TPS fault is suspected, recommended diagnostic test is as follows:

If a computer with diagnostic software is available

Observe throttle percent and raw TPS values through diagnostic software. With diagnostic software communicating to ECU and key ON engine not running, these values can be observed while throttle is moved from closed to full open position. There should be a smooth and repeatable throttle percent value starting at closed position reading between 0 (about 6.5%) to WOT position reading 93 (100%). If one of these values is outside of specified range and output transitions in a smooth manner, reset ECU and run test again. Since there is no longer any wear elements inside sensor, most likely faults will be in electrical connections between sensor and wire harness and wire harness to ECU. With service software communicating to ECU and engine not running, a small load or gentle back and forth motion can be applied to connectors or wires just outside connectors to detect a faulty connection.

If only a volt meter is available

Measure voltage supply to sensor from ECU. This voltage should be 5.00 +/- 0.20 volts. This can be measured by gently probing terminals B & C on harness side with TPS connector removed from TPS and key ON. This will generate a P0122 fault that can be cleared with an ECU reset. If voltage is low, battery, harness and ECU should be investigated. If supply voltage is good, plug sensor back into harness. Probe sensor signal wire with volt meter, terminal A at TPS or pin Black 12 at ECU. This signal should start between 0.6-1.2 volts at low idle and grow smoothly as throttle is opened to 4.3-4.8 volts at full open (WOT). Since there is no longer any wear elements inside sensor, most likely faults will be in electrical connections between sensor and wire harness and wire harness to ECU.

Replace Magnet Assembly

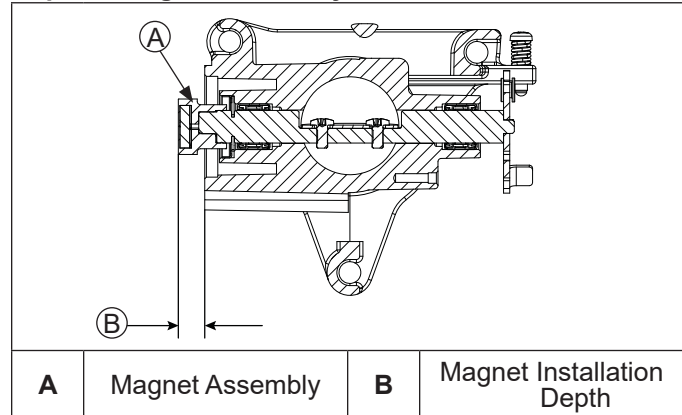

Magnet assembly is captured in a small plastic housing that is press fit to end of throttle shaft. This generally does not need replacement. If replacement is required, can be replaced as follows:

1. Remove sensor from throttle body, exposing round magnet assembly.
2. A pair of flat blade screw drivers or a spanner tool can be used to pry this off shaft. Caution should be used to avoid damage to machined flat surface that sensor seals against. Also, make sure throttle blade is in full open position to avoid driving throttle blade into throttle bore causing damage to blade and/or bore.
3. When replacing magnet assembly, alignment is critical. There is a D-shaped drive feature on end of shaft and a matching pocket in magnet assembly. On outer diameter of magnet assembly is a notch that aligns with center of flat feature of D. Align this notch and flat of D feature in shaft and preassemble parts.
4. With throttle blade in full open position (WOT), press magnet assembly fully on to throttle shaft. Full insertion can be checked by measuring height from throttle body sensor mounting face to end of magnet assembly. This should be no more than 8.6 mm (0.338 in.). Installation process requires significant force, so take care that all parts are aligned. Tapping magnet assembly on can fracture/damage brittle magnet within assembly and throttle body assembly and is NOT RECOMMENDED.

Engine (Oil) Temperature Sensor

A sealed, non-serviceable assembly. A faulty sensor must be replaced. If a blink code indicates a problem with temperature sensor, it can be tested as follows:

1. Remove temperature sensor from breather cover and cap or block sensor hole.
2. Wipe sensor clean and allow it to reach room temperature (25°C, 77°F).
3. Unplug Black connector from ECU.
4. With sensor still connected, check temperature sensor circuit resistance between Black pin 10 and 14 terminals. Value should be 9000-11000 Ω.
5. Unplug sensor from wire harness and check sensor resistance separately across two pins. Resistance value should again be 9000-11000 Ω.
 - a. If resistance is out of specifications, replace temperature sensor.
 - b. If it is within specifications, proceed to Step 6.
6. Check circuits (input, ground), from wire harness connector to sensor plug for continuity, damage, etc. Connect one ohmmeter lead to Black pin 14 in wire harness connector (as in step 4). Connect other lead to terminal #1 in sensor plug. Continuity should be indicated. Repeat test between Black pin 10 and terminal #2 in sensor plug.

Earlier engines have a separate intake air temperature (IAT) sensor (located in throttle body) and a manifold absolute pressure (MAP) sensor (located in intake manifold).

Intake Air Temperature Sensor

A non-serviceable component. Complete replacement is required if it is faulty. Sensor and wiring harness can be checked as follows.

1. Remove temperature sensor from throttle body.
2. Allow it to reach room temperature (20°C, 68°F).
3. Unplug Black connector from ECU.
4. With sensor still connected, check temperature sensor circuit resistance between Black pin 10 and 8 pin terminals. Value should be 3100-3900 Ω.
5. Unplug sensor from wire harness and check sensor resistance separately across two pins. Resistance value should again be 3100-3900 Ω.
 - a. If resistance is out of specifications, replace temperature sensor.
 - b. If it is within specifications, proceed to Step 6.
6. Check circuits (input, ground), from main harness connector to sensor plug for continuity, damage, etc. Connect one ohmmeter lead to Black pin 8 in main harness connector (as in step 4). Connect other lead to terminal #1 in sensor plug. Continuity should be indicated. Repeat test between Black pin 10 and terminal #2 in sensor plug.

Manifold Absolute Pressure Sensor (MAP)

A sealed, non-serviceable assembly. A faulty sensor must be replaced. If a blink code indicates a problem with manifold absolute pressure sensor, it can be tested as follows:

1. Make sure all connections are making proper contact and are free of dirt and debris. Remove blower housing. Slide locking tab out and pull off manifold absolute pressure connector. Turn key switch to ON and check with a volt meter by contacting red lead to pin 1 and black lead to pin 2. There should be 5 volts present, indicating ECU and wiring harness are functioning.
2. Check continuity in wire harness. Ohms between Pin 3 at sensor connector and Black pin 11 connector at ECU should be near zero ohms. If no continuity is measured or very high resistance, replace wire harness.
3. Check to make sure intake manifold is not loose and MAP sensor is not loose. Loose parts would allow a vacuum leak, making MAP sensor report misleading information to ECU.
 - a. Tighten all hardware and perform an ECU Reset and a TPS Learn Procedure to see if MIL will display a fault with MAP sensor again. If MIL finds a fault with MAP sensor, replace it.

Later engines have a combined temperature/manifold absolute pressure (TMAP) sensor (located in intake manifold).

Temperature/Manifold Absolute Pressure (TMAP) Sensor

A sealed non-serviceable integrated sensor that checks both intake air temperature and manifold absolute pressure. Complete replacement is required if it is faulty. Sensor and wiring harness can be checked as follows.

If a blink code indicates a problem with Intake Air Temperature (TMAP) Sensor Circuit (P0112 or P0113), it can be tested as follows:

1. Remove TMAP sensor from intake manifold.
2. Allow it to reach room temperature (20°C, 68°F).
3. Unplug Black connector from ECU.
4. With sensor still connected, check temperature sensor circuit resistance between Black pin 10 and 8 pin terminals. Value should be 1850-2450 Ω.
5. Unplug sensor from wire harness and check sensor resistance separately across pin. Resistance value should again be 1850-2450 Ω.
 - a. If resistance is out of specifications, check local temperature. Sensor resistance will go down as temperature is higher. Replace TMAP sensor if determined to be faulty.
 - b. If it is within specifications, proceed to Step 6.

Propane EFI System

6. Check circuits (input, ground), from main harness connector to sensor plug for continuity, damage, etc. Connect one ohmmeter lead to Black pin 8 in main harness connector (as in step 4). Connect other lead to terminal #3 in sensor plug. Continuity should be indicated. Repeat test between Black pin 10 and terminal #4 in sensor plug.
7. Reinstall sensor.

If a blink code indicates a problem with Manifold Absolute Pressure (TMAP) Sensor Circuit (P0107 or P0108), it can be tested as follows:

1. Make sure all connections are making proper contact and are free of dirt and debris. Slide locking tab out and pull off TMAP connector. Turn key switch to ON and check with a volt meter by contacting red lead to pin 1 and black lead to pin 2. There should be 5 volts present, indicating ECU and wiring harness are functioning.
2. Check continuity in wire harness. Ohms between Pin 3 at sensor connector and Black pin 11 connector at ECU should be near zero ohms. If no continuity is measured or very high resistance, replace wire harness.
3. Check to make sure intake manifold is not loose and TMAP sensor is not loose. Loose parts would allow a vacuum leak, making TMAP sensor report misleading information to ECU.
 - a. Tighten all hardware and perform an ECU Reset and a TPS Learn Procedure to see if MIL will display a fault with sensor again. If MIL finds a fault with TMAP sensor, replace it.

Oxygen Sensor (O₂)

Components

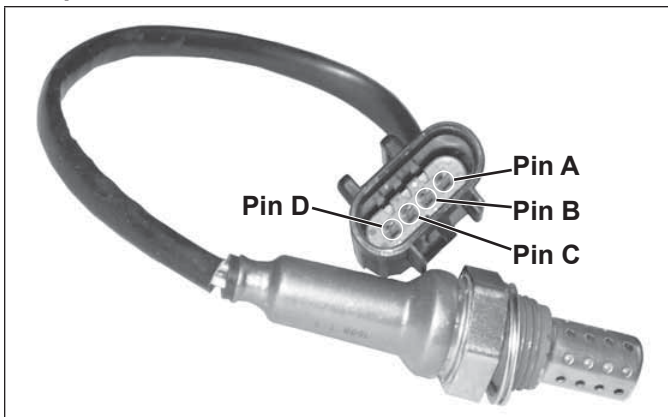

Cutaway Oxygen Sensor Components (O₂)

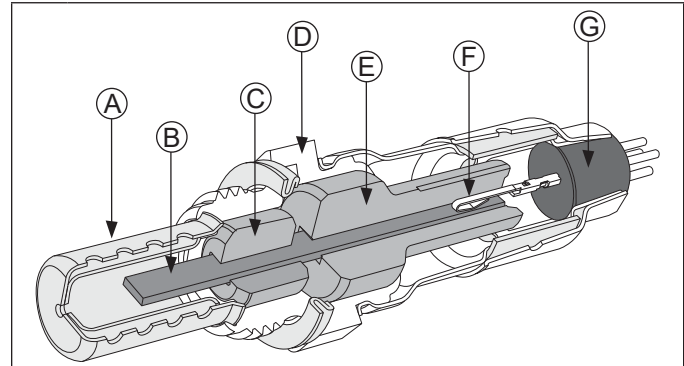

A	Protection Shield	B	Planar Element and Heater
C	Lower Insulator	D	Stainless Steel Housing
E	Upper Insulator	F	Terminal Connection to Element
G	High Temp Water Seal		

Temperature must be controlled very accurately and gas constituents measured to a high degree of accuracy for absolute sensor measurements. This requires laboratory equipment to determine a good or bad sensor in field. Furthermore, as with most devices, intermittent problems are difficult to diagnose. Still, with a good understanding of system and sensor, it is possible to diagnose many sensor problems in field.

Using diagnostic software connected to ECU is a useful technique for observing sensor performance. However, user must understand that such software reads a signal generated by ECU. If there is an ECU or wiring problem, readings could be misinterpreted as a sensor problem. Digital nature of signal to software means that it is not reading continuous output of sensor. A voltmeter can also be used as an effective tool in diagnosing sensors. It is advisable to use an electronic meter such as a digital voltmeter. Simple mechanical meters may place a heavy electrical load on sensor and cause inaccurate readings. Since resistance of sensor is highest at low temperatures, such meters will cause largest inaccuracies when sensor is in a cool exhaust.

Visual Inspection

1. Look for a damaged or disconnected sensor-to-engine harness connection.
2. Look for damage to sensor lead wire or associated engine wiring due to cutting, chaffing or melting on a hot surface.
3. Disconnect sensor connector and look for corrosion in connector.
4. Try reconnecting sensor and observe if problem has cleared.
5. Correct any problems found during visual check.

Sensor Signal Observation

NOTE: **Do not cut into or pierce sensor or engine wiring to make this connection.** Sensor produces a very small signal. Corrosion or damage to wiring could lead to an incorrect signal because of repairs or contamination to sensor.

1. Using a voltmeter, observe voltage between Pin C and Pin D before engine is started. With key ON, and sensor unplugged, voltage should read about 5.0 volts. With sensor attached, using diagnostic software, voltage should read about 1.0 volt. This voltage is generated by ECU. If it is not present, there is a short in associated wiring and corrective action should be taken. If voltage still is not present, there is a problem with ECU or engine harness.
2. Reconnect sensor and start engine. Run engine at sufficient speed to bring sensor up to operating temperature. Maintain for 1 to 2 minutes to ensure that engine has gone closed loop. Once in closed loop, sensor voltage should cycle between about 100 to 250 mv (low speed idle) and 700 to 900 mv (high speed no load). If this cycling is not observed, a determination must be made, if problem is with engine or sensor.
3. Check engine harness for battery voltage on heater circuit.

Removal Inspection

NOTE: Apply anti-seize compound only to threads. **Anti-seize compound will affect sensor performance if it gets into lower shield of sensor.**



1. If sensor has heavy deposits on lower shield, engine, oil, or fuel may be source.
2. If heavy carbon deposits are observed, incorrect engine fuel control may be occurring.
3. If sensor is at room temperature, measure between signal leads, black wire (Pin C) and grey wire (Pin D) attached to sensor. If resistance is less than one megohm, sensor has an internal short.
4. With sensor at room temperature measure heater circuit resistance, purple wire (Pin A) and white wire (Pin B), resistance should be 8.1-11.1 Ω .
5. If a damaged sensor is found, identify root cause, which may be elsewhere in application. Refer to Troubleshooting-Oxygen Sensor (O₂) table.
6. A special "dry to touch" anti-seize compound is applied to all new oxygen sensors at factory. If recommended mounting thread sizes are used, this material provides excellent anti-seize capabilities and no additional anti-seize is needed. If sensor is removed from engine and reinstalled, anti-seize compound should be reapplied. Use an oxygen sensor safe type anti-seize compound. It should be applied according to directions on label.

Propane EFI System

Troubleshooting-Oxygen Sensor (O₂)

Condition	Possible Cause	Conclusion
Low voltage output.	Shorted sensor or sensor circuit. Shorted lead wire. Wiring shorted to ground.	Replace sensor or repair wiring.
	Contamination of air reference.	Remove source of external contamination, protect air reference area.
	Air leak at sensor or gasket, sensor upper shield damage.	Use recommended torque at installation, replace gasket or sensor. Revise application exhaust. Shield sensor from damage.
High voltage output.	Silica poisoning.	Replace sensor.
	Contaminated fuel.	Use high quality fuel.
	Engine problem; misfire.	Correct cause of misfire.
	Excessive rich air/fuel ratio.	Check for high fuel pressure Leaking injector
	Wiring shorted to voltage.	Repair wiring.
Open circuit, no activity from sensor.	Broken element. Sensor dropped. Hard blow to engine or exhaust system. Defective sensor. Thermal shock.	Replace sensor.
Slow time response.	Open heater circuit. Improper handling. Carbon deposits.	Replace sensor.
	Incorrect or contaminated fuel.	Use high quality fuel.
	Excessive engine oil consumption causing exhaust contamination or other exhaust side contamination.	Correct engine condition.
	Heater circuit open/shorted or out of specification.	Repair short in harness wires, replace sensor.

Fuel Injectors

	 WARNING
	<p>High Pressure Fluids can puncture skin and cause severe injury or death.</p> <p>Do not work on fuel system without proper training or safety equipment.</p>
<p>Fluid puncture injuries are highly toxic and hazardous. If an injury occurs, seek immediate medical attention.</p>	

Details

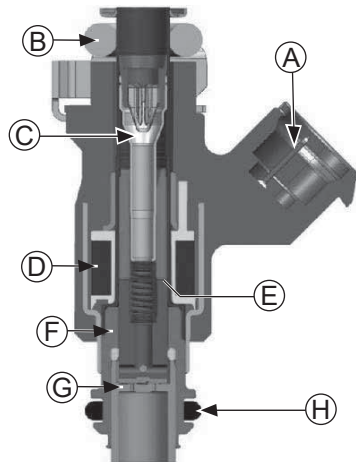

A	Electrical Connection	B	Upper O-ring
C	Inlet Filter/Calibration Tube Assembly	D	Solenoid Winding
E	Armature	F	Valve Housing
G	Valve Seat	H	Lower O-ring
I	Director Plate		

NOTE: Do not apply voltage to fuel injector(s). Excessive voltage will burn out injector(s). Do not ground injector(s) with ignition ON. Injector(s) will open/turn on if relay is energized.

NOTE: When cranking engine with injectors disconnected, fault codes will be registered in ECU and will need to be cleared using software fault clear or an ECU Reset and TPS Learn Procedure.

Injector problems typically fall into three general categories: electrical, dirty/clogged, or leakage. An electrical problem usually causes one or both of injectors to stop functioning. Several methods may be used to check if injectors are operating.

1. With engine running at idle, listen for a buzzing or clicking sound.
2. Disconnect electrical connector from an injector and listen for a change in idle performance (only running on one cylinder) or a change in injector noise or vibration.

If an injector is not operating, it can indicate either a bad injector, or a wiring/electrical connection problem. Check as follows:

1. Disconnect electrical connector from both injectors. Plug a 12 volt noid light into one connector.
2. Make sure all safety switch requirements are met. Crank engine and check for flashing of test light. Turn key OFF for at least 10 seconds between tests to allow ECU to go to sleep and reawake. Repeat test at other connector.
 - a. If flashing occurs, use an ohmmeter (Rx1 scale) and check resistance of each injector across two terminals. Proper resistance is 7-9 Ω . If injector resistance is correct, check whether connector and injector terminals are making a good connection. If resistance is not correct, replace injector.

Check all electrical connections, connectors, and wiring harness leads if resistance is incorrect.

Injector leakage is very unlikely, but in those rare instances it can be internal (past tip of valve needle), or external (weeping around injector O-rings). Loss of system pressure from leakage can cause hot restart problems and longer cranking times. To check for leakage it will be necessary to loosen or remove blower housing which may involve removing engine from unit. Refer to Disassembly for removal of injector.

1. Remove manifold mounting bolts and separate throttle body/manifold from engine leaving TPS, high pressure fuel line, injectors and fuel line connections intact. Discard old gaskets.
2. Position manifold assembly over an appropriate container to capture fuel and turn key switch ON to activate/energize lock-off valve and pressurize system. Do not turn switch to START position.
3. If either injector exhibits leakage of more than two to four drops per minute from tip, or shows any sign of leakage around outer shell, turn ignition switch OFF and replace injector as follows.
4. Depressurize fuel system.
5. Clean any dirt accumulation from sealing/mounting area of faulty injector(s) and disconnect electrical connector(s).
6. Pull retaining clip off top of injector(s). Remove screw holding injector(s) from manifold.

Propane EFI System

- Reverse appropriate procedures to install new injector(s) and reassemble engine. Use new O-rings and retaining clips any time an injector is removed (new replacement injectors include new O-rings and retaining clips). Lubricate O-rings lightly with clean engine oil. Use installation tool provided with O-rings to install new upper O-ring. Place tool into fuel injector inlet. Place one side of O-ring into O-ring groove and roll O-ring over tool onto fuel injector. Torque screw securing fuel injector caps and blower housing mounting screws to 7.3 N·m (65 in. lb.), and intake manifold and air cleaner mounting screws to 10.5 N·m (93 in. lb.). An ECU Reset will need to be completed.

Injector problems due to dirt or clogging are generally unlikely due to design of injectors and high fuel pressure. Symptoms that could be caused by dirty/clogged injectors include rough idle, hesitation/stumbling during acceleration, or triggering of fault codes related to fuel delivery. Injector clogging is usually caused by a buildup of deposits on director plate, restricting flow of fuel, resulting in a poor spray pattern. Some contributing factors to injector clogging include higher than normal operating temperatures, short operating intervals, and dirty, incorrect, or poor quality fuel. Cleaning of clogged injectors is not recommended; they should be replaced.

Ignition Coil

If a coil is determined to be faulty, replacement is necessary. An ohmmeter may be used to test wiring and coil windings.

NOTE: Do not ground primary coil with ignition ON as they may overheat or spark.

NOTE: Always disconnect spark plug lead from spark plug before performing following tests.



NOTE: **If ignition coil(s) are disabled and an ignition fault is registered, system will automatically disable corresponding fuel injector drive signal.** Fault must be corrected to ignition coil and ECU power (switch) must be turned OFF for 10 seconds for injector signal to return. This is a safety measure to prevent bore washing and oil dilution.

Testing

Using an ohmmeter set on Rx1 scale, check resistance in circuits as follows:

- To check cylinder coil 1 (starter side), disconnect Black connector from ECU and test between Black pins 1 and 15. To check cylinder coil 2 (oil filter side), disconnect Grey connector from ECU and test between Grey pins 10 and 17. Wiring and coil primary circuits are OK if readings are 0.5-0.8 Ω .
- If reading(s) are not within specified range, check and clean connections and retest.
- If reading(s) are still not within specified range, test coils separately from main harness as follows:
 - Remove screw retaining coil to housing and disconnect primary leads connector.
 - Connect an ohmmeter set on Rx1 scale to primary terminals of coil. Primary resistance should be 0.5-0.8 Ω .
 - Connect an ohmmeter set on Rx10K scale between spark plug boot terminal and B+ primary terminal. Secondary resistance should be 6400-7800 Ω .
 - If secondary resistance is not within specified range, coil is faulty and needs to be replaced.

FUEL COMPONENTS

	 WARNING
	<p>High Pressure Fluids can puncture skin and cause severe injury or death.</p> <p>Do not work on fuel system without proper training or safety equipment.</p>
<p>Fluid puncture injuries are highly toxic and hazardous. If an injury occurs, seek immediate medical attention.</p>	

Vaporizer/Regulator/Lock-Off

Details

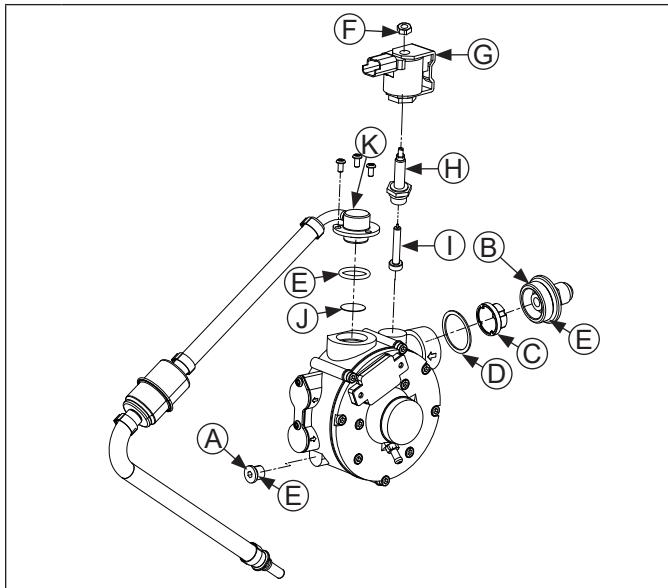

A	Brass Plug	B	Inlet Fitting
C	30-Micron Button Filter	D	Button Filter Gasket
E	O-Ring	F	Nut
G	Lock-Off	H	Lock-Off Valve Body
I	Plunger	J	Screen
K	Outlet Fitting		

Ensure there is an adequate supply of fuel in tank and that fuel valve is turned ON. Vaporizer/Regulator is preset at factory, is not serviceable, and must be replaced if determined to be faulty. If a regulator problem is suspected, make certain lock-off is being activated, all electrical connections are properly secured, fuses are good, and a minimum of 7.0 volts is being supplied. If required, testing of regulator and lock-off may be conducted.

1. Relieve fuel pressure at lock-off. Shut off tank valve. If possible, run engine in a well-ventilated area until fuel system is empty and engine stops. If unable to run engine, work in a well-ventilated area and carefully loosen inlet fuel fitting on vaporizer/regulator, slowly venting off fuel from line. When fuel is dispensed, retighten fitting and remove quick connect fitting to allow fuel to escape from line. Insert pressure test jumper (from Rehlko EFI Service Kit) between high pressure fuel line and fuel lock-off.

2. Turn on key switch to activate lock-off and check system pressure on gauge. If system pressure of 26 psi \pm 3 is observed, wiring, lock-off, and regulator are working properly. Turn key switch OFF and observe system pressure. System pressure should not drop more than 5 psi per minute. If it does drop more than this, a leak may be present in system and should be investigated. If system pressure is OK, depress valve button on tester to relieve system pressure.
 - a. If pressure is too high or too low, replace regulator.
3. If lock-off did not activate (step 2), disconnect plug from lock-off. Connect a DC voltmeter across terminals in plug, turn on key switch and observe if a minimum of 7 volts is present during six second prime process.
4. If no voltage is observed, connect red lead of meter to red wire of plug and black lead to a good ground while key is still ON.
5. If voltage is between 7 and 14, turn key switch OFF and connect an ohmmeter between terminals on lock-off to check for continuity.
 - a. If there was no continuity between lock-off terminals, replace lock-off valve.
 - b. If voltage was below 7, test wiring harness and battery.
6. If voltage at plug was good, and there was continuity across lock-off terminals, reconnect plug to lock-off, making sure you have a good connection. Turn on key switch and listen for lock-off to activate.
 - a. If lock-off clicks, repeat steps 1 and 2 to verify correct pressure.
 - b. If lock-off still does not operate, replace it.

Propane EFI System

Regulator Maintenance

Drain Accumulated Deposits

Over time, depending on fuel quality, operating environment, and system performance, fuel deposits can accumulate inside regulator. Perform following steps to remove any accumulated deposits.

1. Turn supply valve off, run engine out of fuel, and turn off ignition switch.
2. Disconnect and ground spark plug leads.
3. Remove brass plug from bottom of regulator and drain any accumulated deposits.
4. Inspect O-ring on plug; replace if damaged.
5. Reinstall plug and tighten securely.

Replace 30-Micron Button Filter

Remove inlet fitting w/O-ring, button filter and gasket. Discard filter, gasket, and O-Ring. Position new gasket into regulator, install button filter (large end in). Install new O-ring on inlet fitting. Reinstall inlet fitting and torque to 20 N·m (177 in. lb.).

Lock-Off Assembly

1. Disconnect plug from lock-off. Remove nut and lock-off. Remove lock-off valve body and plunger. Discard all parts.
2. Install plunger, then lock-off valve body. Torque body to 20 N·m (177 in. lb.).
3. Install lock-off assembly and nut. Torque nut to 6.5 N·m (57 in. lb.).
4. Reconnect plug to lock-off.

High Pressure Fuel Line

High pressure fuel line is mounted to intake manifold. No specific servicing is required unless operating conditions indicate that it needs replacement. Thoroughly clean area around all joints and relieve any pressure before starting any disassembly. Detach by removing two mounting screws, wire ties, and injector retaining clips.

Vacuum Reference Line

No specific servicing is required for vacuum line unless operating conditions indicate replacement is required. All components are serviced individually. Abrasion sleeves on hoses should be reused or replaced when servicing vacuum line. Please note routing and replicate after service or component replacement to prevent pinching or abrasion of line. Only Rehlko replacement parts can be used because vacuum line is specific to system and must be maintained. Visit engines.rehlko.com for recommended Rehlko replacement parts.

Throttle Body/Intake Manifold Assembly

NOTE: ECU Reset is required if throttle body is replaced.

Throttle body is serviced as an assembly, with throttle shaft, TPS, throttle plate, and idle speed adjusting screw installed. Throttle shaft rotates on needle bearings (non-serviceable), capped with seals to prevent air leaks.

TROUBLESHOOTING

Troubleshooting Guide

Condition	Possible Cause
Engine Starts Hard or Fails to Start When Cold.	Lock-off not functioning.
	Faulty spark plugs.
	Incorrect fuel.
	Incorrect fuel pressure.
	Crankshaft position sensor loose or faulty.
	TPS set incorrect (ECU Reset and TPS Learn).
	TPS faulty.
	Engine temp sensor faulty.
	Faulty coils.
	Low system voltage.
	Faulty injectors.
	Faulty battery.
Loose or corroded connections.	

Troubleshooting Guide

Condition	Possible Cause
Engine Starts Hard or Fails to Start When Hot.	Faulty spark plugs.
	Lock-off not functioning.
	Fuel pressure low.
	Insufficient fuel delivery.
	TPS set incorrect (ECU Reset and TPS Initialization).
	Crankshaft position sensor loose or faulty.
	TPS faulty.
	Engine temp sensor faulty.
Engine Stalls or Idles Roughly (cold or warm).	Faulty spark plugs.
	Insufficient fuel delivery.
	TPS set incorrect.
	TPS faulty.
	Faulty engine temperature sensor.
Engine Misses, Hesitates, or Stalls Under Load.	Fuel injector(s), fuel filter, or fuel line.
	Dirty air cleaner.
	Insufficient fuel pressure or fuel delivery.
	Vacuum (intake air) leak.
	Improper governor setting, adjustment or operation.
	TPS faulty, mounting problem or TPS Initialization Procedure incorrect.
	Bad coil(s), spark plug(s), or wires.
Low Power	Faulty/malfunctioning ignition system.
	Dirty air filter.
	Insufficient fuel delivery or pressure.
	Improper governor adjustment.
	Plugged/restricted exhaust.
	One injector not working.
	Basic engine problem exists.
	TPS faulty or mounting exists.
	Throttle plate in throttle body not fully opening to WOT stop (if equipped).

Propane EFI System

Fault Codes

Example of Diagnostic Display

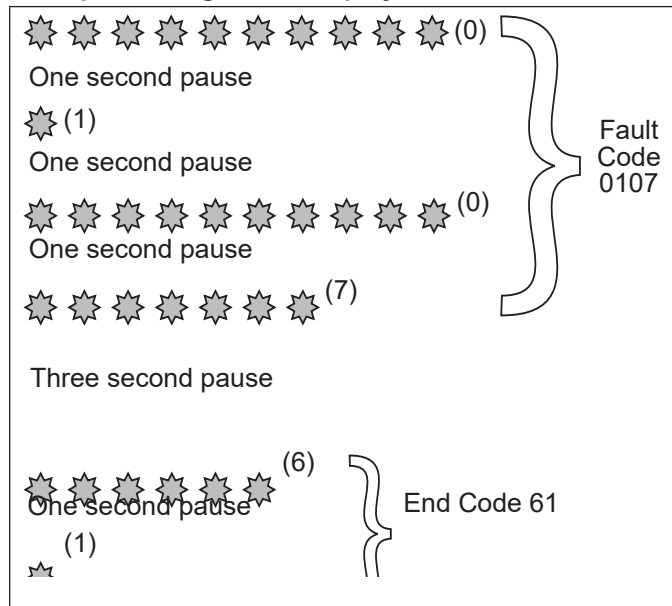

Diagnostic Fault Code Summary

Fault Code	Connection or Failure Description
0031	Oxygen Sensor Heater Circuit Low Voltage
0032	Oxygen Sensor Heater Circuit High Voltage
0107	Manifold Absolute Pressure (MAP or TMAP) Sensor Circuit Low Voltage or Open
0108	Manifold Absolute Pressure (MAP or TMAP) Sensor Circuit High Voltage
0112	Intake Air Temperature (IAT or TMAP) Sensor Circuit Low Voltage
0113	Intake Air Temperature (IAT or TMAP) Sensor Circuit High Voltage or Open
0117	Coolant/Oil Temperature Sensor Circuit Low Voltage
0118	Coolant/Oil Temperature Sensor Circuit High Voltage or Open
0122	Throttle Position Sensor Circuit Low Voltage or Open
0123	Throttle Position Sensor Circuit High Voltage
0131	Oxygen Sensor 1 Circuit Low Voltage, or Open
0132	Oxygen Sensor 1 Circuit High Voltage
0171	Maximum Adaptation Limit Exceeded
0172	Minimum Adaptation Limit Exceeded
0174	Lean Fuel Condition at High Load (Open Loop)
0201	Injector 1 Circuit Malfunction
0202	Injector 2 Circuit Malfunction
0230	Fuel Lock-Off Circuit Low Voltage or Open
0232	Fuel Lock-Off Circuit High Voltage
0336	Crankshaft Position Sensor Noisy Signal
0337	Crankshaft Position Sensor No Signal
0351	Cylinder 1 Ignition Coil Malfunction
0352	Cylinder 2 Ignition Coil Malfunction
0562	System Voltage Low
0563	System Voltage High
61	End of Code Transmission

ECU continuously monitors engine operation against preset performance limits. If operation is outside limits, ECU activates MIL, if equipped, and stores a diagnostic code in its fault memory. If component or system returns to proper function, ECU will turn off MIL. If MIL stays illuminated, it warns customer a fault is currently happening, and dealer service is required. Upon receipt, dealer technician can access fault code(s) to help determine what portion of system is malfunctioning.

Codes are accessed through key switch and displayed as blinks or flashes of MIL. Access codes as follows:

1. Check that battery voltage is above 11 volts.
2. Start with key switch OFF.
3. Turn key switch to ON and OFF, then ON and OFF, then ON, leaving it on in third sequence. Do not start engine. Time between sequences must be less than 2.5 seconds.
4. MIL will blink a series of times. Number of times MIL blinks represents a number in blink code.
5. A sequence of four digits make up a fault code. There is a one (1) second pause between blinks of a fault code. There is a three (3) second pause between separate fault codes. After fault code(s) are blinked a two digit 61 is blinked to indicate program has completed.
 - a. It's a good idea to write down codes as they appear, as they may not be in numerical sequence.
 - b. Code 61 will always be last code displayed, indicating end of code transmission. If code 61 appears immediately, no other fault codes are present.

After problem has been corrected, fault codes may be cleared by following ECU Reset and TPS Learn Procedures.

Diagnostic Fault Code Summary lists fault codes, and what they correspond to. Diagnostic Code Summary is a list of individual codes with an explanation of what triggers them, what symptoms might be expected, and probable causes.

A MIL may not be provided with engine. If equipment manufacturer has not added a MIL to equipment, one can be added easily for quick diagnostics. Main engine to vehicle connection will have a tan wire which is ground for MIL. Either incandescent or LED type bulbs can be used for MIL as long as they do not draw more than 0.1 amps. Bulb needs to be rated at 1.4 Watts or less, or needs to have a total resistance of 140 Ω or more. LEDs typically draw less than 0.03 amps. Attach +12 volts to positive terminal of bulb and attach ground terminal of bulb to tan wire.

Diagnostic Code Summary

Code 0031

Component:	Oxygen Sensor Heater
Fault:	O2S Heater Circuit Low Voltage
Condition:	System voltage too low, open connection or faulty sensor.
Conclusion:	<p>Engine Wiring Harness Related</p> <ul style="list-style-type: none"> ● Pin circuit wiring or connectors. ECU black pin 7 or broken wire. <p>Oxygen Sensor Related</p> <ul style="list-style-type: none"> ● Sensor connector or wiring problem. <p>Poor system ground from ECU to engine or battery to engine.</p>

Code 0032

Component:	Oxygen Sensor Heater
Fault:	O2S Heater Circuit High Voltage
Condition:	System voltage too high, shorted connection or faulty sensor.
Conclusion:	<p>Oxygen Sensor Related</p> <ul style="list-style-type: none"> ● Sensor connector or wiring problem. ● Sensor damaged. ● Pin circuit wiring or connectors at Black 7. <p>ECU Related</p> <ul style="list-style-type: none"> ● ECU-to-harness connection problem.

Code 0107

Component:	Manifold Absolute Pressure (MAP or TMAP) Sensor
Fault:	MAP or TMAP Circuit Low Voltage or Open
Condition:	Intake manifold leak, open connection or faulty sensor.
Conclusion:	<p>MAP or TMAP Sensor Related</p> <ul style="list-style-type: none"> ● Sensor malfunction. ● Vacuum leaks from loose manifold or sensor. <p>Wire Harness Related</p> <ul style="list-style-type: none"> ● Poor grounding or open circuit. ● Wire harness and connectors loose, damaged or corroded. ● Pin circuit wiring or connectors at Black 10, 11 and 16. <p>Bad TPS Learn.</p>

Propane EFI System

Code 0108

Component:	Manifold Absolute Pressure (MAP or TMAP) Sensor
Fault:	MAP or TMAP Circuit High Voltage
Condition:	Intake manifold leak, shorted connection or faulty sensor.
Conclusion:	<p>MAP or TMAP Sensor Related</p> <ul style="list-style-type: none"> • Sensor malfunction. • Vacuum leaks from loose manifold or sensor. <p>Wire Harness Related</p> <ul style="list-style-type: none"> • Poor grounding. • Pin circuit wiring or connectors at Black 11. <p>Bad TPS Learn.</p>

Code 0112

Component:	Intake Air Temperature (IAT or TMAP) Sensor
Fault:	Intake Air Temperature (IAT or TMAP) Sensor Circuit Low Voltage
Condition:	Shorted connection, faulty sensor or shorted wire.
Conclusion:	<p>Temperature (IAT or TMAP) Sensor Related</p> <ul style="list-style-type: none"> • Sensor wiring or connection. <p>Engine Wiring Harness Related</p> <ul style="list-style-type: none"> • Pin circuits Black 10 and Black 8 may be damaged or routed near noisy signal (coils, alternator, etc.). • ECU-to-harness connection problem.

Code 0113

Component:	Intake Air Temperature (IAT or TMAP) Sensor
Fault:	Intake Air Temperature (IAT or TMAP) Sensor Circuit High Voltage or Open
Condition:	Shorted connection, faulty sensor, broken wire or connection.
Conclusion:	<p>Temperature (IAT or TMAP) Sensor Related</p> <ul style="list-style-type: none"> • Sensor wiring or connection. <p>Engine Wiring Harness Related</p> <ul style="list-style-type: none"> • Pin circuits ECU Black pin 10 and 8 may be damaged. • ECU-to-harness connection problem or broken wire.

Code 0117

Component:	Coolant/Oil Sensor
Fault:	Coolant/Oil Temperature Sensor Circuit Low Voltage
Condition:	Shorted connection, faulty sensor or shorted wire.
Conclusion:	<p>Temperature Sensor Related</p> <ul style="list-style-type: none"> • Sensor wiring or connection. <p>Engine Wiring Harness Related</p> <ul style="list-style-type: none"> • Pin circuits Black 10 and Black 14 maybe damaged or routed near noisy signal (coils, stator, etc.). • ECU-to-harness connection problem.

Code 0118

Component:	Coolant/Oil Sensor
Fault:	Coolant/Oil Temperature Sensor Circuit High Voltage or Open
Condition:	Shorted connection, faulty sensor, open connection or broken wire.
Conclusion:	<p>Temperature Sensor Related</p> <ul style="list-style-type: none"> • Sensor wiring or connection. <p>Engine Wiring Harness Related</p> <ul style="list-style-type: none"> • Pin circuits ECU Black pin 10 and 14 may be damaged. • ECU-to-harness connection problem or broken wire. <p>System Related</p> <ul style="list-style-type: none"> • Engine is operating above 176°C (350°F) temperature sensor limit.

Code 0122

Component:	Throttle Position Sensor (TPS)
Fault:	TPS Circuit Low Voltage or Open
Condition:	Open connection, broken wire or faulty sensor.
Conclusion:	<p>TPS Related</p> <ul style="list-style-type: none"> • TPS bad or worn internally. <p>Engine Wiring Harness Related</p> <ul style="list-style-type: none"> • Broken or shorted wire in harness. <ul style="list-style-type: none"> ECU Black pin 10 to TPS pin 1. ECU Black pin 12 to TPS pin 3. ECU Black pin 16 to TPS pin 2. <p>Throttle Body Related</p> <ul style="list-style-type: none"> • Throttle shaft inside TPS worn, broken, or damaged. • Throttle plate loose or misaligned. • Throttle plate bent or damaged allowing extra airflow past, or restricting movement. <p>ECU Related</p> <ul style="list-style-type: none"> • Circuit providing voltage or ground to TPS damaged. • TPS signal input circuit damaged.

Code 0123

Component:	Throttle Position Sensor (TPS)
Fault:	TPS Circuit High Voltage
Condition:	Shorted connection or faulty sensor.
Conclusion:	<p>TPS Sensor Related</p> <ul style="list-style-type: none"> • Sensor connector or wiring. • Sensor output affected or disrupted by dirt, grease, oil, wear. • Sensor loose on throttle body manifold. <p>Throttle Body Related</p> <ul style="list-style-type: none"> • Throttle shaft or bearings worn/damaged. <p>Engine Wiring Harness Related</p> <ul style="list-style-type: none"> • ECU pins Black 10, 12 and 16 damaged (wiring, connectors). • ECU pins Black 10, 12 and 16 routed near noisy electrical signal (coils, alternator). • Intermittent 5 volt source from ECU (pin Black 16). • ECU-to-harness connection problem.

Code 0131

Component:	Oxygen Sensor
Fault:	O2S 1 Circuit Low Voltage
Condition:	Open connection, broken wire or faulty sensor.
Conclusion:	<p>Oxygen Sensor Related</p> <ul style="list-style-type: none"> • Sensor connector or wiring problem. • Sensor contaminated, corroded or damaged. • Poor ground path. • Pin circuit wiring or connectors. <ul style="list-style-type: none"> ECU Black pin 10 or 17. <p>TPS Learn Procedure Incorrect</p> <ul style="list-style-type: none"> • Lean condition (check oxygen sensor signal with VOA and see Oxygen Sensor section). <p>Engine wiring harness related such as a cut wire, broken or pinched.</p>

Code 0132

Component:	Oxygen Sensor
Fault:	O2S 1 Circuit High Voltage
Condition:	Shorted connection or faulty sensor.
Conclusion:	<p>Oxygen Sensor Related</p> <ul style="list-style-type: none"> • Sensor connector or wiring problem. • Sensor contaminated or damaged. • Poor ground path. • Pin circuit wiring or connectors. <ul style="list-style-type: none"> ECU Black pin 10 or Black pin 17. <p>Engine Wiring Harness Related</p> <ul style="list-style-type: none"> • Difference in voltage between sensed voltage and actual sensor voltage. • Short in wire harness.

Propane EFI System

Code 0171

Component:	Fuel System
Fault:	Maximum adaptation limit exceeded
Condition:	Fuel filters plugged, low pressure at high pressure fuel line, TPS malfunction, shorted connection, faulty sensor, low fuel or wrong fuel type.
Conclusion:	<p>Oxygen Sensor Related</p> <ul style="list-style-type: none"> ● Corrosion or poor connection. ● Sensor contaminated or damaged. ● Air leak into exhaust. ● Poor ground path. ● Pin circuit wiring or connectors. ECU Black pin 10 or Black pin 17. <p>TPS Sensor Related</p> <ul style="list-style-type: none"> ● Throttle plate position incorrect during Learn procedure. ● TPS problem or malfunction. <p>Engine Wiring Harness Related</p> <ul style="list-style-type: none"> ● Difference in voltage between sensed voltage and actual sensor voltage. ● Problem in wiring harness. ● ECU-to-harness connection problem. <p>Systems Related</p> <ul style="list-style-type: none"> ● Ignition (spark plug, plug wire, ignition coil). ● Fuel (fuel type/quality, injector, fuel pressure too low, fuel lock-off or regulator). ● Combustion air (air cleaner dirty/restricted, intake leak, throttle bores). ● Base engine problem (rings, valves). ● Exhaust system leak (muffler, flange, oxygen sensor mounting boss, etc.).

Code 0172

Component:	Fuel System
Fault:	Minimum adaptation limit exceeded
Condition:	Too high pressure at high pressure fuel line, TPS malfunction, shorted connection, faulty sensor or regulator failure.
Conclusion:	<p>Oxygen Sensor Related</p> <ul style="list-style-type: none"> ● Sensor connector or wiring. ● Sensor contaminated or damaged. ● Poor ground path. ● Pin circuit wiring or connectors. ECU Black pin 10 or 17. <p>TPS Sensor Related</p> <ul style="list-style-type: none"> ● Throttle plate position incorrect during Learn procedure. ● TPS problem or malfunction. <p>Engine Wiring Harness Related</p> <ul style="list-style-type: none"> ● Difference in voltage between sensed voltage and actual sensor voltage. ● Problem in wiring harness. ● ECU-to-harness connection problem. <p>Systems Related</p> <ul style="list-style-type: none"> ● Ignition (spark plug, plug wire, ignition coil). ● Fuel (fuel type/quality, injector, fuel pressure too high, fuel regulator). ● Combustion air (air cleaner dirty/restricted). ● Base engine problem (rings, valves).

Code 0174

Component:	Fuel System
Fault:	Lean fuel condition
Condition:	Fuel filters plugged, low pressure at high pressure fuel line, TPS malfunction, shorted connection or faulty sensor.
Conclusion:	<p>TPS Learn Incorrect</p> <ul style="list-style-type: none"> Lean condition (check oxygen sensor signal with VOA and see Oxygen Sensor). <p>Engine Wiring Harness Related</p> <ul style="list-style-type: none"> Pin circuit wiring or connectors. ECU pin Black 10, 12, 16 and 17. <p>Low Fuel Pressure</p> <ul style="list-style-type: none"> Low/empty fuel tank. Plugged filters. Bad regulator. <p>Oxygen Sensor Related</p> <ul style="list-style-type: none"> Sensor connector or wiring problem. Exhaust leak. Poor ground. <p>Poor system ground from ECU to engine, causing rich running while indicating lean.</p> <p>Fuel lock-off connection. See Fuel Components.</p>

Code 0201

Component:	Fuel Injector
Fault:	Injector 1 Circuit Malfunction
Condition:	Injector damaged or faulty, shorted or open connection.
Conclusion:	<p>Injector Related</p> <ul style="list-style-type: none"> Injector coil shorted or opened. <p>Engine Wiring Harness Related</p> <ul style="list-style-type: none"> Broken or shorted wire in harness. ECU pin Black 5. Wiring from Ignition. <p>ECU Related</p> <ul style="list-style-type: none"> Circuit controlling injector #1 damaged.

Code 0202

Component:	Fuel Injector
Fault:	Injector 2 Circuit Malfunction
Condition:	Injector damaged or faulty, shorted or open connection.
Conclusion:	<p>Injector Related</p> <ul style="list-style-type: none"> Injector coil shorted or opened. <p>Engine Wiring Harness Related</p> <ul style="list-style-type: none"> Broken or shorted wire in harness. ECU pin Black 6. Wiring from Ignition. <p>ECU Related</p> <ul style="list-style-type: none"> Circuit controlling injector #2 damaged.

Code 0230

Component:	Fuel Lock-off
Fault:	Circuit Low Voltage or Open
Condition:	Shorted or open connection.
Conclusion:	<p>Fuel Lock-off Related</p> <ul style="list-style-type: none"> Fuel lock-off open or shorted internally. <p>Engine Wiring Harness related</p> <ul style="list-style-type: none"> Broken or shorted wire in harness. ECU pin Black 9 or Grey 17. <p>ECU Related</p> <ul style="list-style-type: none"> ECU is damaged.

Code 0232

Component:	Fuel Lock-off
Fault:	Circuit High Voltage
Condition:	Shorted connection.
Conclusion:	<p>Fuel Lock-off Related</p> <ul style="list-style-type: none"> Fuel lock-off damaged internally. <p>Charging Output System Too High.</p>

Propane EFI System

Code 0336

Component:	Crankshaft Position Sensor
Fault:	Crankshaft Position Sensor Noisy Signal
Condition:	Air gap incorrect, loose sensor, faulty/bad battery, shorted or faulty connection, faulty sensor or faulty sensor grounding.
Conclusion:	<p>Crankshaft Position Sensor Related</p> <ul style="list-style-type: none"> • Sensor connector or wiring. • Sensor loose or air gap incorrect. <p>Crankshaft Position Sensor Wheel Related</p> <ul style="list-style-type: none"> • Damaged teeth. • Gap section not registering. <p>Engine Wiring Harness Related</p> <ul style="list-style-type: none"> • Pin circuit wiring or connectors. ECU pin Black 4 and Black 13. • ECU-to-harness connection problem. <p>Ignition System Related</p> <ul style="list-style-type: none"> • Non-resistor spark plug(s) used. • Faulty or disconnected ignition coil or secondary lead.

Code 0337

Component:	Crankshaft Position Sensor
Fault:	Crankshaft Position Sensor No Signal
Condition:	Air gap incorrect, loose sensor, open or shorted connection or faulty sensor.
Conclusion:	<p>Crankshaft Position Sensor Related</p> <ul style="list-style-type: none"> • Sensor connector or wiring. • Sensor loose or air gap incorrect. <p>Crankshaft Position Sensor Wheel Related</p> <ul style="list-style-type: none"> • Damaged teeth. <p>Engine Wiring Harness Related</p> <ul style="list-style-type: none"> • Pin circuit wiring or connectors. ECU pin Black 4 or Black 13. • ECU-to-harness connection problem. <p>If code is stored in fault history and starts normally. Clear code, no other service required.</p>

Code 0351

Component:	Ignition Coil
Fault:	Cylinder 1 Ignition Coil Malfunction
Condition:	Broken wire in harness (may not be visible), shorted connection or faulty sensor.
Conclusion:	<p>Engine Wiring Harness Related</p> <ul style="list-style-type: none"> • Connection to ignition or fuse. • Pin circuit wiring or connectors. • ECU pin Black 1. • ECU-to-harness connection problem. <p>Ignition System Related</p> <ul style="list-style-type: none"> • Incorrect spark plug(s) used. • Poor connection to spark plug.

Code 0352

Component:	Ignition Coil
Fault:	Cylinder 2 Ignition Coil Malfunction
Condition:	Broken wire in harness (may not be visible), shorted connection or faulty sensor.
Conclusion:	<p>Engine Wiring Harness Related</p> <ul style="list-style-type: none"> • Connection to ignition or fuse. • Pin circuit wiring or connectors. ECU pin Grey 10. • ECU-to-harness connection problem. <p>Ignition System Related</p> <ul style="list-style-type: none"> • Incorrect spark plug(s) used. • Poor connection to spark plug.

Code 0562

Component:	System Voltage
Fault:	System Voltage Low
Condition:	Faulty voltage regulator, bad fuse or shorted connection.
Conclusion:	<p>Corroded Connections</p> <p>Bad Stator</p> <p>Bad Battery</p> <ul style="list-style-type: none"> • Low output charging system. • Poor magnet in flywheel. • Bad or missing fuse.

Code 0563

Component:	System Voltage
Fault:	System Voltage High
Condition:	Faulty voltage regulator or shorted connection.
Conclusion:	<p>Faulty Rectifier-Regulator</p> <p>Bad Stator.</p> <p>Bad Battery.</p>

Code 61

Component:	End of Code Transmission
------------	--------------------------

Troubleshooting Flow Chart

Following flow chart provides an alternative method of troubleshooting EFI system. Chart will enable you to review entire system in about 10-15 minutes. Using chart, accompanying diagnostic aids (listed chart), and any signaled fault codes, you should be able to quickly locate any problems within system.

Flow Chart Diagnostic Aids

Diagnostic Aid #1 SYSTEM POWER

(MIL does not illuminate when key is turned ON)

NOTE: MIL is installed by vehicle OEM. Twelve volt supply to bulb will be part of vehicle wire harness. Rehlko key switch model will have MIL on engine with 12V supply to bulb.

Conclusion

- Battery
- Main system fuse
- MIL light bulb burned out
- MIL electrical circuit problem
 - Pin circuits Grey 3.
- Ignition switch
- Permanent ECU power circuit problem
 - Pin circuit Black 18.
- Switched ECU power circuit problem
 - Pin circuit Black 15.
- ECU grounds
- ECU

Diagnostic Aid #2 FAULT CODES

Refer to Diagnostic Fault Code Summary.

Diagnostic Aid #3 RUN/ON

(MIL remains ON while engine is running)*

Condition

NOTE: Either incandescent or LED type bulbs can be used for MIL as long as they do not draw more than 0.1 amps. Bulb needs to be rated at 1.4 Watts or less, or needs to have a total resistance of 140 Ω or more. LEDs typically draw less than 0.03 amps.

*All current fault codes will turn on MIL when engine is running.

Diagnostic Aid #4 CRANKSHAFT POSITION SENSOR

(MIL does not turn off during cranking)

Condition

- Crankshaft position sensor
- Crankshaft position sensor circuit problem, pin circuits Black 4 and Black 13.
- Crankshaft position sensor/toothed wheel air gap
- Toothed wheel
- Flywheel key sheared
- ECU

Diagnostic Aid #5 FUEL LOCK-OFF

(lock-off not activating)

Condition

- Main fuse
- Fuel lock-off circuit problem, pin circuits Black 9 and Grey 17.
- Fuel lock-off

Diagnostic Aid #6 IGNITION SYSTEM

(no spark)

Condition

- Spark plug
- Plug wire
- Coil
- Coil circuit(s), pin circuits Grey 10 and Black 1.
- ECU grounds
- ECU
- Vehicle safety interlocks, ground signal on safety wire.

Diagnostic Aid #7 FUEL SYSTEM ELECTRICAL

(no fuel delivery)

Condition

- No fuel
- Air in high pressure fuel line
- Fuel valve shut OFF
- Fuel filter/line plugged
- Injector circuit(s), pin circuits Black 5 and Black 6
- Injector
- ECU grounds
- ECU

Diagnostic Aid #8 FUEL SYSTEM

(fuel pressure)

Low Fuel Pressure-Condition

- Low fuel/insufficient fuel supply
- Fuel filter plugged
- Fuel supply line plugged
- Pressure regulator not functioning properly.

Diagnostic Aid #9 BASIC ENGINE

(cranks but will not run)

Condition

- Refer to basic engine troubleshooting charts within Troubleshooting.

Propane EFI System

EFI Diagnostic Flow Diagram

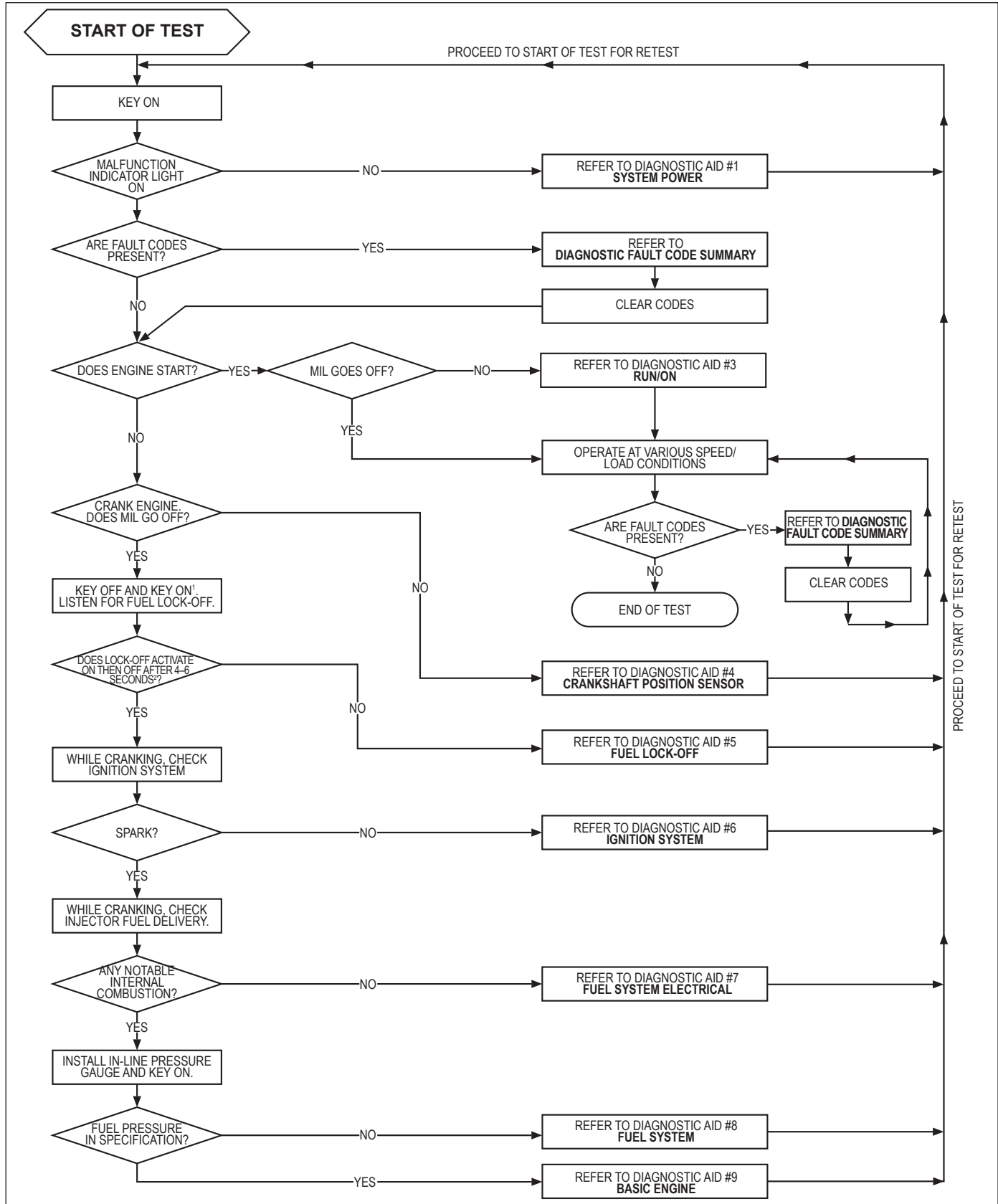

1. After turning key to OFF, wait 10 seconds before turning to ON to allow ECU to go to sleep.
2. Fuel lock-off can be heard or felt to establish lock-off opening. Fuel lock-off will stay activated for one 4-6 second cycle when ECU wakes up after being asleep (key ON, not cranking).

This engine uses a full pressure lubrication system which delivers oil under pressure to crankshaft, camshaft, connecting rod bearing surfaces, and hydraulic valve lifters.

A high-efficiency gerotor oil pump maintains high oil flow and oil pressure, even at low speeds and high operating temperatures. A pressure relief valve limits maximum pressure of system. Closure plate must be removed to service oil pickup, pressure relief valve, and oil pump.

Lubrication Components

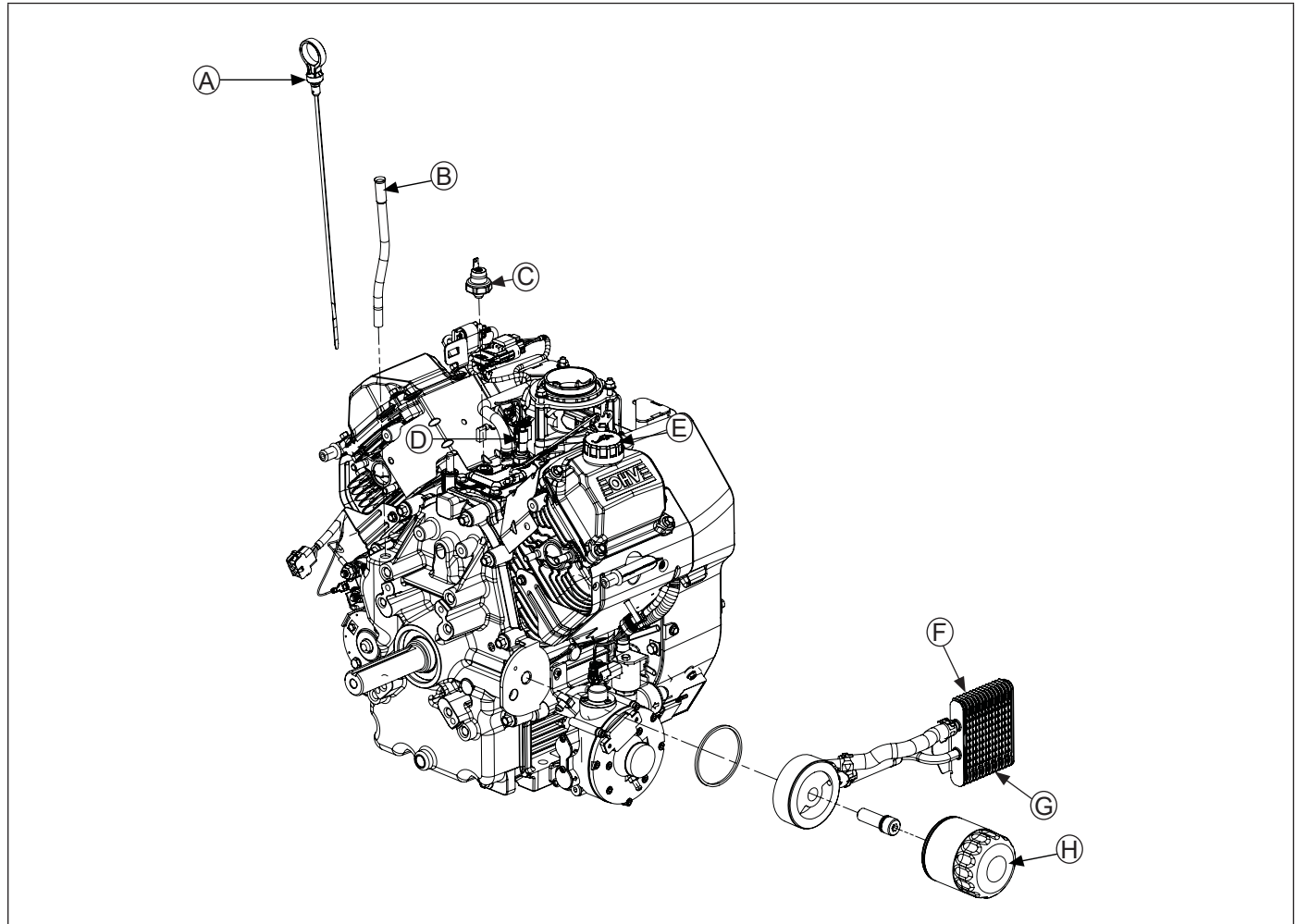

A	Dipstick	B	Dipstick Tube	C	Oil Sentry™	D	Oil Pressure Switch	E	Oil Fill
F	Back Side	G	Oil Cooler	H	Oil Filter				

OIL RECOMMENDATIONS

Refer to Maintenance.

CHECK OIL LEVEL

NOTE: To prevent extensive engine wear or damage, never run engine with oil level below or above operating range indicator on dipstick.

Ensure engine is cool. Clean oil fill/dipstick areas of any debris.

1. Remove dipstick; wipe oil off.
2. Reinsert dipstick into tube; press completely down.
3. Remove dipstick; check oil level. Level should be at top of indicator on dipstick.
4. If oil is low on indicator, add oil up to top of indicator mark.
5. Reinstall and secure dipstick.

Lubrication System

CHANGE OIL AND FILTER

Change oil while engine is warm.

1. Clean area around oil fill cap/dipstick and drain plug. Remove drain plug and oil fill cap/dipstick. Allow oil to drain completely.
2. Clean area around oil filter. Place a container under filter to catch any oil and remove filter. Wipe off mounting surface. Reinstall drain plug. Torque to 13.6 N·m (10 ft. lb.).
3. Place new filter in shallow pan with open end up. Fill with new oil until oil reaches bottom of threads. Allow 2 minutes for oil to be absorbed by filter material.
4. Apply a thin film of clean oil to rubber gasket on new filter.
5. Refer to instructions on oil filter for proper installation.
6. Fill crankcase with new oil. Level should be at top of indicator on dipstick.
7. Reinstall oil fill cap/dipstick and tighten securely.
8. Start engine; check for oil leaks. Stop engine; correct leaks. Recheck oil level.
9. Dispose of used oil and filter in accordance with local ordinances.

OIL COOLER (if equipped)

1. Clean fins with a brush or compressed air.
2. Remove screws securing oil cooler and tilt to clean back side.
3. Reinstall oil cooler and secure with screws. Torque top screw to 2.8 N·m (25 in. lb.) and lower screw to 2.3 N·m (20 in. lb.).

OIL SENTRY™ (if equipped)

This switch is designed to prevent engine from starting in a low oil or no oil condition. Oil Sentry™ may not shut down a running engine before damage occurs. In some applications this switch may activate a warning signal. Read your equipment manuals for more information.

Oil Sentry™ pressure switch is installed in breather cover. On engines not equipped with Oil Sentry™ installation hole is sealed with a 1/8-27 N.P.T.F. pipe plug.

Installation

1. Apply pipe sealant with Teflon® (Loctite® PST® 592™ Thread Sealant or equivalent) to threads of switch.
2. Install switch into tapped hole in breather cover.
3. Torque switch to 4.5 N·m (40 in. lb.).

Testing

Compressed air, a pressure regulator, pressure gauge, and a continuity tester are required to test switch.

1. Connect continuity tester across blade terminal and metal case of switch. With 0 psi pressure applied to switch, tester should indicate no continuity (switch open).
2. Gradually increase pressure to switch. As pressure increases through range of 2.0/5.0 psi, tester should indicate a change to continuity (switch closed). Switch should remain closed as pressure is increased to 90 psi maximum.
3. Gradually decrease pressure through range of 2.0/5.0 psi. Tester should indicate a change to no continuity (switch open) down to 0 psi.

SPARK PLUGS



⚠ CAUTION

Electrical Shock can cause injury.
Do not touch wires while engine is running.

Spark Plug Component and Details

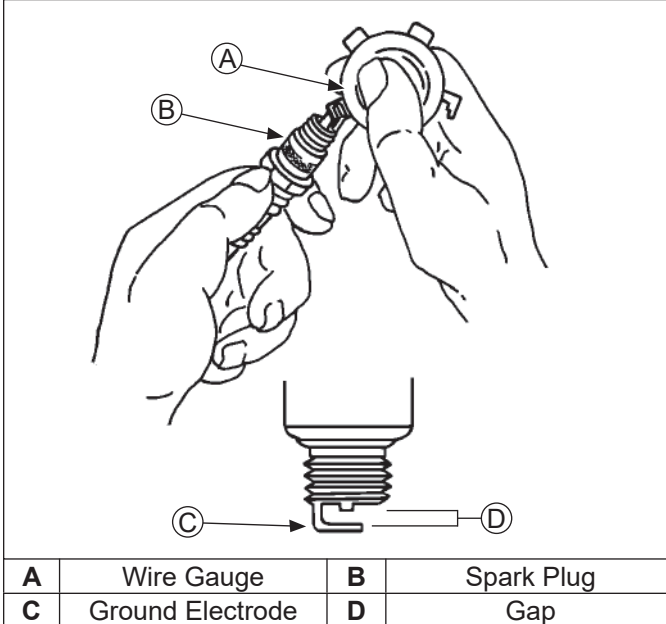

NOTE: Do not clean spark plug in a machine using abrasive grit. Some grit could remain in spark plug and enter engine causing extensive wear and damage.

Engine misfire or starting problems are often caused by a spark plug that has improper gap or is in poor condition.

Engine is equipped with following spark plugs:

Gap	0.76 mm (0.030 in.)
Thread Size	14 mm
Reach	19.1 mm (3/4 in.)
Hex Size	15.9 mm (5/8 in.)

Refer to Maintenance for Repairs/Service Parts.

Service

Clean out spark plug recess. Remove plug and replace.

1. Check gap using wire feeler gauge. Adjust gap to 0.76 mm (0.030 in.).
2. Install plug into cylinder head.
3. Torque plug to 27 N·m (20 ft. lb.).

Inspection

Inspect each spark plug as it is removed from cylinder head. Deposits on tip are an indication of general condition of piston rings, valves, and fuel system.

Normal and fouled plugs are shown in following photos:

Normal

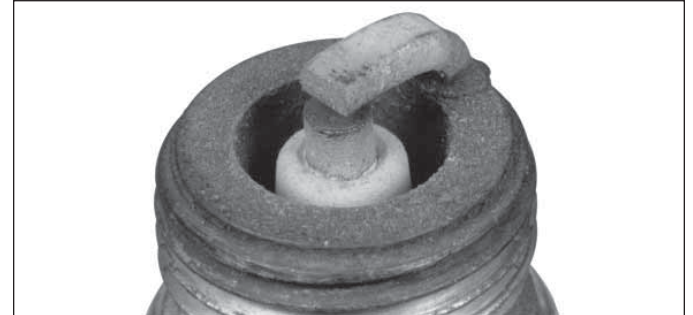

Plug taken from an engine operating under normal conditions will have light tan or gray colored deposits. If center electrode is not worn, plug can be set to proper gap and reused.

Worn



On a worn plug, center electrode will be rounded and gap will be greater than specified gap. Replace a worn spark plug immediately.

Wet Fouled



A wet plug is caused by excess fuel or oil in combustion chamber. Excess fuel could be caused by a restricted air cleaner, a fuel system problem, or operating engine with too much choke. Oil in combustion chamber is usually caused by a restricted air cleaner, a breather problem, worn piston rings, or valve guides.

Electrical System

Carbon Fouled



Soft, sooty, black deposits indicate incomplete combustion caused by a restricted air cleaner, over rich settings, weak ignition, or poor compression.

Overheated



Chalky, white deposits indicate very high combustion temperatures. This condition is usually accompanied by excessive gap erosion. Lean settings, an intake air leak, or incorrect spark timing are normal causes for high combustion temperatures.

BATTERY

A 12-volt battery with 400 cold cranking amps (cca) is generally recommended for starting in all conditions. A smaller capacity battery is often sufficient if an application is started only in warmer temperatures. Refer to following table for minimum capacities based on anticipated ambient temperatures. Actual cold cranking requirement depends on engine size, application, and starting temperatures. Cranking requirements increase as temperatures decrease and battery capacity shrinks. Refer to equipment's operating instructions for specific battery requirements.

Battery Size Recommendations

Temperature	Battery Required
Above 32°F (0°C)	200 cca minimum
0°F to 32°F (-18°C to 0°C)	250 cca minimum
-5°F to 0°F (-21°C to -18°C)	300 cca minimum
-10°F (-23°C) or below	400 cca minimum

If battery charge is insufficient to turn over engine, recharge battery.

Battery Maintenance

Regular maintenance is necessary to prolong battery life.

Battery Test

To test battery, follow manufacturer's instructions.

BATTERY CHARGING SYSTEM

NOTE: Observe following guidelines to avoid damage to electrical system and components:

- Make sure battery polarity is correct. A negative (-) ground system is used.
- Disconnect rectifier-regulator plug and/or wiring harness plug before doing any electric welding on equipment powered by engine. Also, disconnect all other electrical accessories in common ground with engine.
- Prevent stator (AC) leads from touching or shorting while engine is running. This could damage stator.

These engines are equipped with a 20 or 25 amp regulated charging system.

20/25 Amp Regulated Charging System

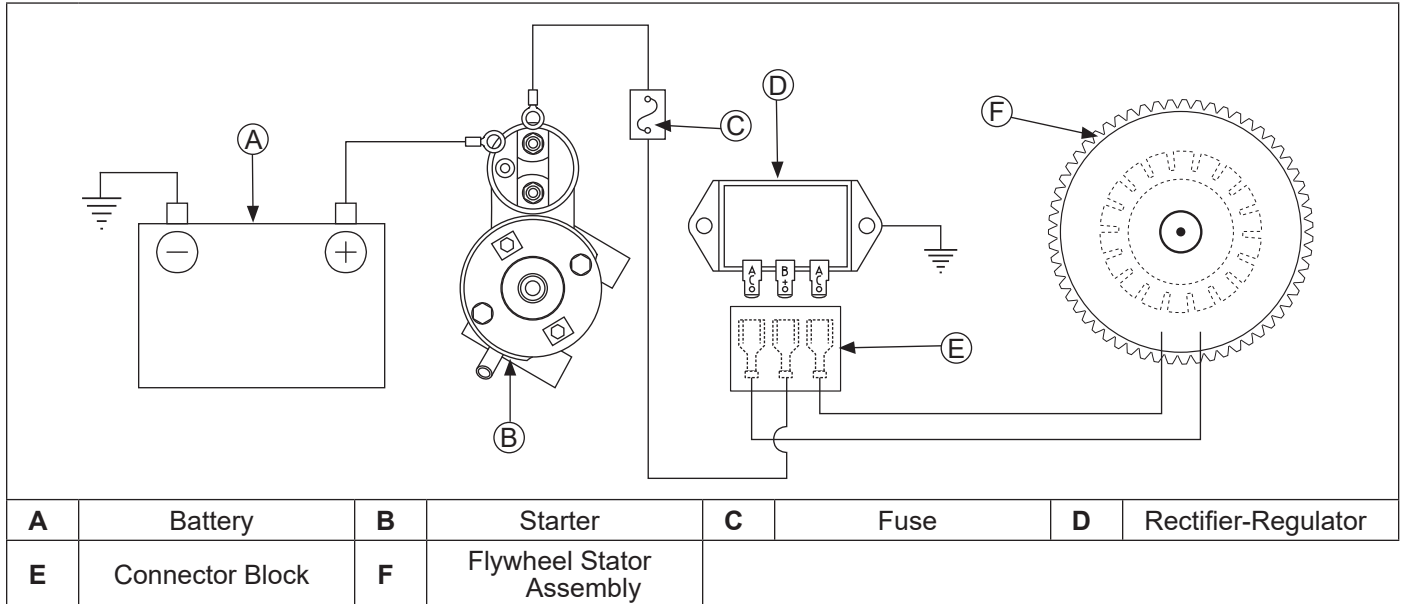

Stator

Stator is mounted on crankcase behind flywheel. Follow procedures in Disassembly and Reassembly if stator replacement is necessary.

Rectifier-Regulator

NOTE: When installing rectifier-regulator, take note of terminal markings and install plug(s) accordingly.

NOTE: Disconnect all electrical connections attached to rectifier-regulator. Testing may be performed with rectifier-regulator mounted or loose. Repeat applicable test procedure 2 or 3 times to determine condition of part.

Rectifier-regulator is mounted on blower housing. To replace, disconnect plug(s), remove mounting screws, and ground wire or metal grounding strap.

Testing rectifier-regulator may be performed as follows, using appropriate rectifier-regulator tester.

To test 20/25 amp rectifier-regulators:

1. Connect tester ground lead (with spring clamp) to body of rectifier-regulator.
2. Connect red lead from tester to middle terminal labeled B+.
3. Connect black leads from tester to both outer AC terminals on rectifier-regulator.
4. Plug tester into proper AC outlet/power for tester being used. Turn on power switch. POWER light should be illuminated and one of four status lights may be lit as well. This does not represent condition of part.
5. Press TEST button until a click is heard and then release. Momentarily one of four status lights will illuminate indicating partial condition of part.

Electrical System

Condition	Conclusion
20/25 amp	
OK (green) light comes on and stays steady.	Disconnect tester black lead attached to 1 AC terminal and reconnect it to other AC terminal. Repeat test. If OK (green) light comes on again, part is good and may be used.
NOTE: A flashing LOW light can also occur as a result of an inadequate ground lead connection. Make certain connection location is clean and clamp is secure. Other lights come on.	Rectifier-regulator is faulty and should not be used.

Troubleshooting Guide

20/25 Amp Battery Charging System

NOTE: Always zero digital volt-ohm meter (DVOM) on each scale before testing to ensure accurate readings. Voltage test should be made with engine running at specific test condition noted. Battery should be checked for state of charge (non-operating voltage 12.5 VDC or lower, battery should be charged or replaced).

When problems occur in keeping a battery fully charged or a battery charges at a high rate, battery or charging system may be cause of fault. Before performing any testing, battery must be fully charged.

To test charging system:

1. Visually inspect system components and wiring. Look for damaged or loose wire connections, including battery cables.
2. Set DVOM to DC volts, place one lead of tester on rectifier-regulator body and other lead to battery negative (-) terminal. Run engine and observe volt reading on meter. If voltage is 0.5 VDC or less continue with testing. If voltage is higher than 0.5 VDC, inspect and repair wiring/connections as needed (insufficient ground).
3. Perform these output tests for charging system using DVOM set to DC volts.
 - a. With engine off and key switch in OFF position, measure voltage at battery. If less than 12.4 VDC, recharge battery and retest. If 12.5 VDC continue with tests.
 - b. Run engine at high speed no load (greater than 3000 RPM). After running 1 minute, measure voltage at battery.
 - i. If voltage increases to between 13-15 VDC, the system is working correctly.
 - ii. If voltage increases to 15.5 VDC or higher, system is overcharging. Replace rectifier-regulator.
 - iii. If voltage stays at 12.5 VDC or decreases, charging system is NOT operating, proceed to step 4.
4. With engine off, unplug rectifier-regulator connector and inspect connector terminals within connector body and rectifier-regulator terminals for corrosion/ arcing/damage. Repair/replace as needed. If OK, proceed to next test.

5. Set DVOM to AC volts, place test leads to each white stator wire. Run engine at 1200 RPM or greater and monitor voltage.

Condition	Conclusion
Voltage is 13 volts AC or more.	Stator is OK.
Voltage is less than 13 volts AC.	Stator is faulty. Continue with steps 6 and 7.

6. With engine off and stator unplugged from rectifier-regulator, check for resistance/continuity between across stator leads (white wires).

Condition	Conclusion
Resistance is 0.1/0.2 ohms.	Stator coil is OK.
Resistance is 0 ohms.	Stator is shorted; replace.
Resistance is infinity ohms/no continuity.	Stator is open; replace.

7. With engine off and stator unplugged from rectifier-regulator, check for resistance/continuity from stator leads (white wires) to ground.

Condition	Conclusion
Resistance is infinity ohms (no continuity).	Stator is OK (not shorted to ground).
Resistance (or continuity) measured.	Stator leads are shorted to ground; replace.

8. If stator tests good (steps 4-7), but system was identified in step 3 as not working, failure is likely with rectifier-regulator. Replace rectifier-regulator, retest system to confirm repairs (step 3).

FUSES

This engine has 3 blade type automotive fuses. Replacement fuses must have same rating as blown fuse. Use fuse chart below to determine correct fuse.

Wire Color	Fuse Rating
2 Purple Wires	30-amp Fuse
1 Red Wire w/Black Stripe 1 Red Wire w/White Stripe	10-amp Fuse
2 Red Wires	10-amp Fuse

Fuse Replacement

1. Shut engine off and remove key.
2. Locate fuse holders.
3. Remove fuse cover and pull out fuse.
4. Inspect fuse for a solid fusible link or a broken fusible link. Replace fuse if fusible link is broken. If you are not sure if fusible link is broken, replace fuse.
5. Insert fuse into fuse holder until it is seated properly. Install fuse cover.

Starter System

NOTE: Do not crank engine continuously for more than 10 seconds. Allow a 60 second cool down period between starting attempts. Failure to follow these guidelines can burn out starter motor.

NOTE: If engine develops sufficient speed to disengage starter but does not keep running (a false start), engine rotation must be allowed to come to a complete stop before attempting to restart engine. If starter is engaged while flywheel is rotating, starter pinion and flywheel ring gear may clash and damage starter.

NOTE: If starter does not crank engine, shut off starter immediately. Do not make further attempts to start engine until condition is corrected.

NOTE: Do not drop starter or strike starter frame. Doing so can damage starter.

Engines in this series use solenoid shift starters.

Troubleshooting-Starting Difficulties

Condition	Possible Cause	Conclusion
Starter does not energize.	Battery	Check specific gravity of battery. If low, recharge or replace battery as necessary.
	Wiring	Clean corroded connections and tighten loose connections. Replace wires in poor condition and with frayed or broken insulation.
	Starter Switch or Solenoid	By-pass switch or solenoid with a jumper wire. If starter cranks normally, replace faulty components. Remove and perform individual solenoid test procedure.
Starter energizes but turns slowly.	Battery	Check specific gravity of battery. If low, recharge or replace battery as necessary.
	Brushes	Check for excessively dirty or worn brushes and commutator. Clean using a coarse cloth (not emery cloth). Replace brushes if excessively or unevenly worn.
	Transmission or Engine	Make sure clutch or transmission is disengaged or placed in neutral. This is especially important on equipment with hydrostatic drive. Transmission must be exactly in neutral to prevent resistance which could keep engine from starting. Check for seized engine components such as bearings, connecting rod, and piston.

SOLENOID SHIFT ELECTRIC STARTERS

Solenoid Shift Starter Components

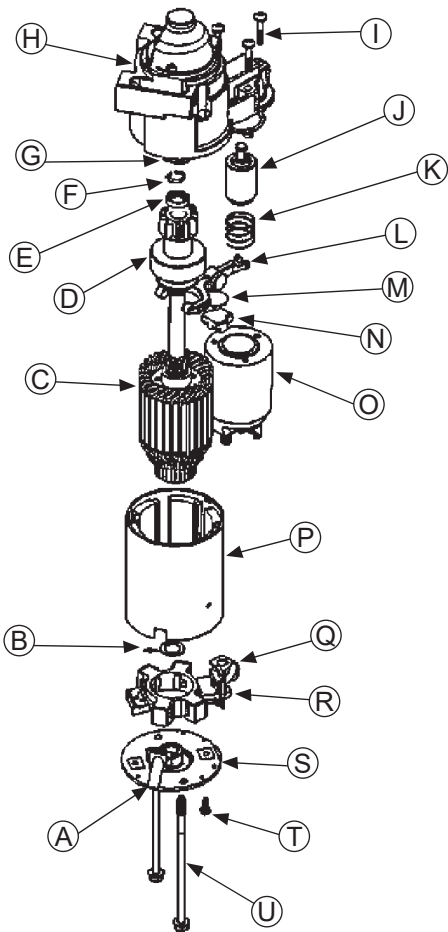

A	Tube	B	Washer
C	Armature	D	Drive
E	Stop	F	Retaining Ring
G	Collar	H	Drive End Cap
I	Screw	J	Plunger
K	Spring	L	Lever
M	Plate	N	Plug
O	Solenoid	P	Frame and Field
Q	Brush Holder	R	Nut
S	Commutator End Plate	T	Screw
U	Bolt		

When power is applied to starter, armature rotates. As armature rotates, drive pinion moves out on drive shaft splines and into mesh with flywheel ring gear. When pinion reaches end of drive shaft, it rotates flywheel and cranks engine.

When engine starts, flywheel rotates faster than starter armature and drive pinion. This moves drive pinion out of mesh with ring gear and into retracted position. When power is removed from starter, armature stops rotating and drive pinion is held in retracted position by anti-drift spring.

Starter Disassembly

NOTE: Do not reuse old retainer.

NOTE: Do not soak armature or use solvent when cleaning. Wipe clean using a soft cloth, or use compressed air.

1. Remove nut and disconnect positive (+) brush lead/ bracket from solenoid terminal.
2. Remove screws securing solenoid to starter.
3. Remove retaining ring from armature shaft using either a retaining ring pliers or snap ring removal tool, as described in Steps 4, and 5. Do not reuse old retainer.
4. Remove thru (larger) bolts.
5. Remove commutator end plate assembly, containing brush holder, brushes, springs, and locking caps. Remove thrust washer from inside commutator end.
6. Remove frame from armature and drive end cap.
7. Remove rubber grommet and backing plate from end cap.
8. Take out drive lever and pull armature out of drive end cap.
9. Remove thrust washer from armature shaft.
10. Push stop collar down to expose retaining ring.
11. Remove retainer from armature shaft. Save stop collar.
12. Remove drive pinion assembly from armature.
13. Clean parts as required.

Inspection

Check drive pinion and inspect following areas:

- Pinion teeth for abnormal wear or damage.
- Surface between pinion and clutch mechanism for nicks or irregularities which could cause seal damage.
- Check drive clutch by holding clutch housing and rotating pinion. Pinion should rotate in only 1 direction.

Brushes and Springs

Detail

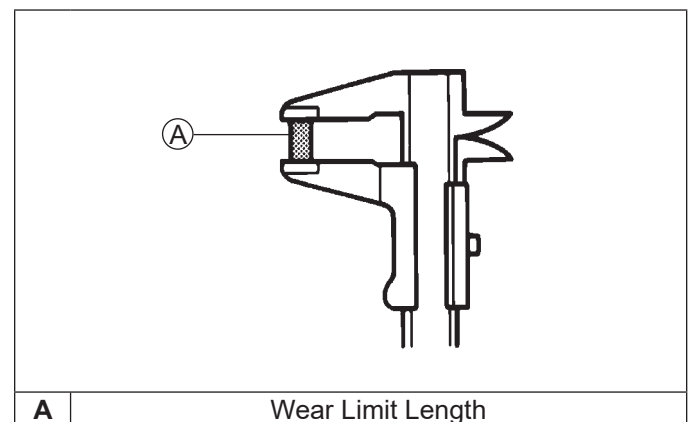

Inspect both springs and brushes for wear, fatigue, or damage. Measure length of each brush. Minimum length for each brush is 7.6 mm (0.300 in.). Replace brushes if they are worn, undersize, or condition is questionable.

Starter System

Armature Components and Details

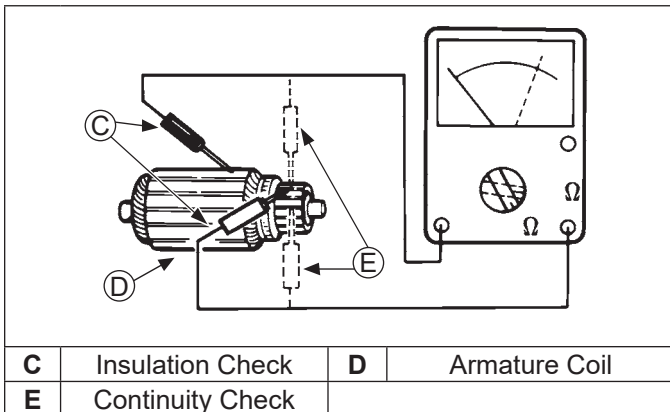
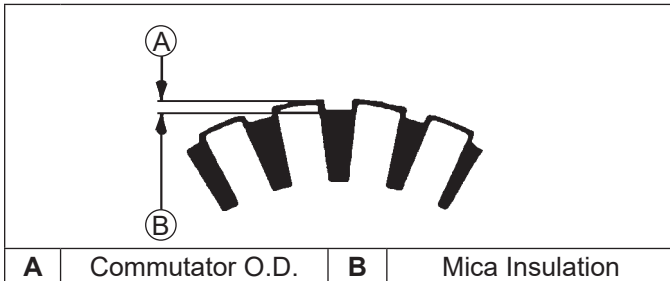

1. Clean and inspect commutator (outer surface). Mica insulation must be lower than commutator bars (undercut) to ensure proper operation of commutator.
2. Use an ohmmeter set to Rx1 scale. Touch probes between 2 different segments of commutator, and check for continuity. Test all segments. Continuity must exist between all or armature is bad.
3. Check for continuity between armature coil segments and commutator segments. There should be no continuity. If continuity exists between any 2 armature is bad.
4. Check armature windings/insulation for shorting.

Shift Fork

Check that shift fork is complete, and pivot and contact areas are not excessively worn, cracked, or broken.

Brush Replacement

4 brushes and springs are serviced as a set. Use a new Rehlko brush and spring kit if replacement is necessary.

1. Perform steps 1-5 in Starter Disassembly.
2. Remove screws securing brush holder assembly to end cap (plate). Note orientation for reassembly later. Discard old brush holder assembly.
3. Clean component parts as required.
New brushes and springs come preassembled in a brush holder with a protective sleeve that will also serve as an installation tool.
4. Perform steps 10-13 in Starter Reassembly sequence. If starter has been disassembled, installation must be done after armature, drive lever, and frame are installed.

Starter Reassembly

NOTE: Always use a new retainer. Do not reuse old retainers that have been removed.

NOTE: Correctly installed, center pivot section of drive lever will be flush or below machined surface of housing.

1. Apply drive lubricant to armature shaft splines. Install drive pinion onto armature shaft.
 2. Install and assemble stop collar/retainer assembly.
 - a. Install stop collar down onto armature shaft with counter bore (recess) up.
 - b. Install a new retainer in larger (rear) groove of armature shaft. Squeeze with a pliers to compress it in groove.
 - c. Slide stop collar up and lock it into place, so recess surrounds retainer in groove. If necessary, rotate pinion outward on armature splines against retainer to help seat collar around retainer.
 3. Install offset thrust (stop) washer so smaller offset of washer faces retainer/collar.
 4. Apply a small amount of oil to bearing in drive end cap, and install armature with drive pinion.
 5. Lubricate fork end and center pivot of drive lever with drive lubricant. Position fork end into space between captured washer and rear of pinion.
 6. Slide armature into drive end cap and at same time seat drive lever into housing.
 7. Install rubber grommet into matching recess of drive end cap. Molded recesses in grommet should be out, matching and aligned with those in end cap.
 8. Install frame, with small notch forward, onto armature and drive end cap. Align notch with corresponding section in rubber grommet. Install drain tube in rear cutout, if it was removed previously.
 9. Install flat thrust washer onto commutator end of armature shaft.
 10. Starter reassembly when replacing brushes/brush holder assembly:
 - a. Hold starter assembly vertically on end housing, and carefully position assembled brush holder assembly, with supplied protective tube, against end of commutator/armature. Mounting screw holes in metal clips must be up/out. Slide brush holder assembly down into place around commutator, and install positive (+) brush lead grommet in cutout of frame. Protective tube may be saved and used for future servicing.
- Starter reassembly when not replacing brushes/brush holder assembly:
- a. Carefully unhook retaining caps from brush assemblies. Do not lose springs.

- b. Position brushes back in their slots so they are flush with I.D. of brush holder assembly. Insert brush installation tool (with extension), or use tube described above from a prior brush installation, through brush holder assembly, so holes in metal mounting clips are up/out.
 - c. Install brush springs and snap on retainer caps.
 - d. Hold starter assembly vertically on end housing, and carefully place tool (with extension) and assembled original brush holder assembly onto end of armature shaft. Slide brush holder assembly down into place around commutator, install positive (+) brush lead grommet in cutout of frame.
11. Install end cap onto armature and frame, aligning thin raised rib in end cap with corresponding slot in grommet of positive (+) brush lead.
 12. Install thru bolts and brush holder mounting screws. Torque bolts to 5.6-9.0 N·m (49-79 in. lb.) and brush holder mounting screws to 2.5-3.3 N·m (22-29 in. lb.).
 13. Hook plunger behind upper end of drive lever and install spring into solenoid. Insert mounting screws through holes in drive end cap. Use these to hold solenoid gasket in position, then mount solenoid. Torque screws to 4.0-6.0 N·m (35-53 in. lb.).
 14. Connect positive (+) brush lead/bracket to solenoid and secure with nut. Torque nut to 8-11 N·m (71-97 in. lb.). Do not overtighten.

Solenoid Tests

NOTE: DO NOT leave 12 volt test leads connected to solenoid for any time over what is necessary for performing each of individual tests. Internal damage to solenoid may occur.

Disconnect all leads from solenoid including positive brush lead attached to lower stud terminal. Remove mounting hardware and separate solenoid from starter for testing.

To test solenoid pull-in coil/plunger:

Actuation

1. Use a 12 volt power supply and 2 test leads.
2. Connect 1 lead to flat spade S/start terminal on solenoid. Momentarily connect other lead to lower large post terminal.

When connection is made solenoid should energize (audible click) and plunger retract. Repeat test several times.

Continuity

1. Use an ohmmeter set to audible or Rx2K scale, and connect 2 ohmmeter leads to 2 large post terminals.
2. Perform solenoid pull-in coil/plunger actuation test and check for continuity. Ohmmeter should indicate continuity. Repeat test several times.

To test solenoid hold-in coil:

Function

1. Connect a 12 volt test lead to flat spade S/start terminal on solenoid and other lead to body or mounting surface of solenoid.
2. Manually push plunger IN and check if coil holds plunger retracted. Do not allow test leads to remain connected to solenoid for a prolonged period of time.

Continuity

1. Use an ohmmeter set to audible or Rx2K scale, and connect 2 ohmmeter leads to 2 large post terminals.
2. Perform preceding solenoid hold-in coil function test and check for continuity. Meter should indicate continuity. Repeat test several times.

Condition	Conclusion
Solenoid fails to activate.	Replace solenoid.
No continuity is indicated.	
Plunger fails to stay retracted.	

Disassembly/Inspection and Service

	⚠ WARNING	<p>Before working on engine or equipment, disable engine as follows: 1) Disconnect spark plug lead(s). 2) Disconnect negative (-) battery cable from battery.</p> <p>Before disconnecting negative (-) ground cable, make sure all switches are OFF. If ON, a spark will occur at ground cable terminal which could cause an explosion if hydrogen gas or propane fuel vapors are present.</p>
	<p>Accidental Starts can cause severe injury or death.</p> <p>Disconnect and ground spark plug lead(s) before servicing.</p>	

External Engine Components

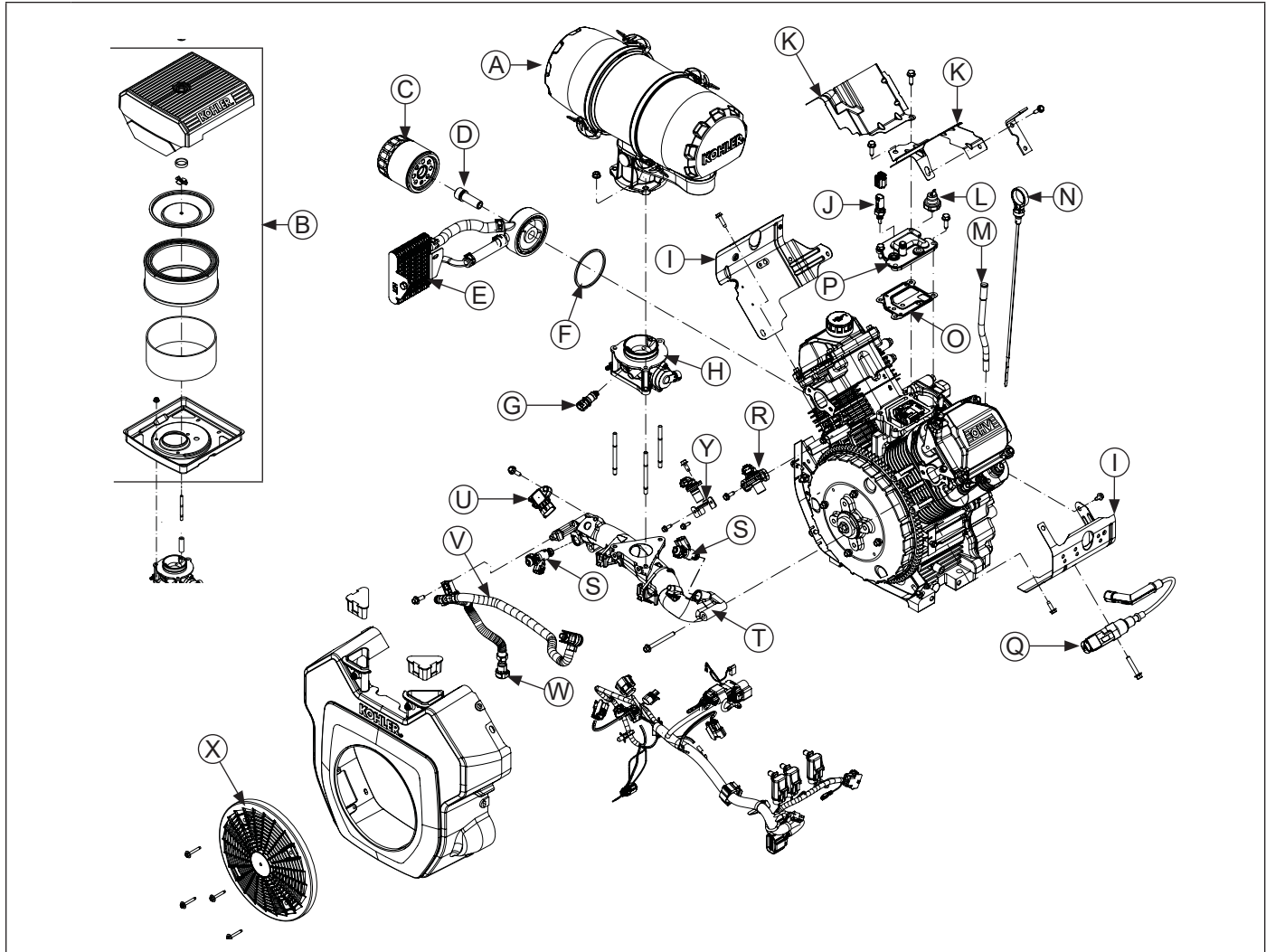

A	Heavy-Duty Air Cleaner	B	Low-Profile Air Cleaner	C	Oil Filter	D	Nipple
E	Oil Cooler	F	Oil Cooler O-Ring	G	Air Temperature Sensor	H	Throttle Body Assembly
I	Barrel Baffle	J	Oil Temperature Sensor	K	Valley Baffle	L	Oil Sentry™
M	Dipstick Tube	N	Dipstick	O	Breather Cover Gasket	P	Breather Cover
Q	Ignition Coil	R	Crankshaft Position Sensor (Earlier Design Bracket)	S	Gaseous Propane Fuel Injector	T	Intake Manifold

U	MAP or TMAP Sensor	V	High Pressure Fuel Line Assembly	W	Fuel Quick Connect	X	Debris Screen
Y	Crankshaft Position Sensor (Later Design Bracket)						

Clean all parts thoroughly as engine is disassembled. Only clean parts can be accurately inspected and gauged for wear or damage. There are many commercially available cleaners that will quickly remove grease, oil, and grime from engine parts. When such a cleaner is used, follow manufacturer's instructions and safety precautions carefully.

Make sure all traces of cleaner are removed before engine is reassembled and placed into operation. Even small amounts of these cleaners can quickly break down lubricating properties of engine oil.

Shut off Fuel Supply/Empty System

	⚠ WARNING
	Explosive Fuel can cause fires and severe burns. If a gaseous odor is detected, ventilate area and contact an authorized service technician.
Propane is extremely flammable and is heavier than air and tends to settle in low areas where a spark or flame could ignite gas. Do not start or operate this engine in a poorly ventilated area where leaking gas could accumulate and endanger safety of persons in area. To ensure personal safety, installation and repair of propane fuel supply systems must be performed only by qualified propane system technicians. Improperly installed and maintained propane equipment could cause fuel supply system or other components to malfunction, causing gas leaks. Observe federal, state and local laws governing propane fuel, storage, and systems.	

1. Relieve fuel pressure at lock-off. Shut off tank valve. If possible, run engine in a well-ventilated area until fuel system is empty and engine stops. If unable to run engine, work in a well-ventilated area and carefully loosen inlet fuel fitting on vaporizer/regulator, slowly venting off fuel from line. When fuel is dispensed, retighten fitting and remove quick connect fitting to allow fuel to escape from line.

Disconnect Spark Plug Leads

NOTE: Pull on boot only, to prevent damage to spark plug lead.

Disconnect leads from spark plugs.

Drain Oil from Crankcase and Remove Oil Filter

NOTE: Some models are equipped with an oil drain valve.

1. Remove oil fill cap/dipstick, and 1 oil drain plug.
2. Allow ample time for oil to drain from crankcase and oil filter.
3. Remove mounting screw and oil fill tube.
4. Remove and discard oil filter.

Remove Oil Cooler

1. Use an 8 mm Allen wrench to remove oil filter threaded nipple.
2. Separate filter adapter from closure plate, leaving oil lines attached. Remove screws mounting oil cooler to blower housing, then remove cooler, lines, and filter adapter with O-ring, as an assembly.

Remove Muffler

NOTE: Removing oxygen sensor is not required to remove exhaust system.

1. Remove exhaust system and attaching hardware from engine.
2. Disconnect oxygen sensor connector from wire harness.

Remove Air Cleaner Assembly

Heavy Duty Air Cleaner

1. Remove nuts securing air cleaner to mounting studs.
2. Remove screws securing air cleaner assembly to mounting bracket and remove air cleaner assembly.

Low-Profile Air Cleaner (Optional)

1. Loosen retaining knob and remove cover.
2. Remove wing nut from element cover.
3. Remove element cover, element and precleaner.
4. Remove nuts securing base. Additional screws must be removed from lower air cleaner support bracket.
5. Remove base.

Remove Control Panel Assembly (If Equipped)

1. Disconnect cables from throttle levers.
2. Remove screws fastening control panel and remove panel from blower housing.

Disassembly/Inspection and Service

Remove External Governor Controls

NOTE: To aid in reassembly, mark hole locations of governor spring, throttle linkage spring, throttle linkage, before removing them from governor lever.

1. Disconnect governor spring attached to governor lever. Note/mark hole location for reassembly.
2. Note/mark hole location, then disconnect throttle linkage spring from governor lever. Remove throttle linkage bushing and throttle linkage from governor lever. Note/mark hole location for reassembly.
3. Loosen nut and remove governor lever from cross shaft.

External Governor Controls

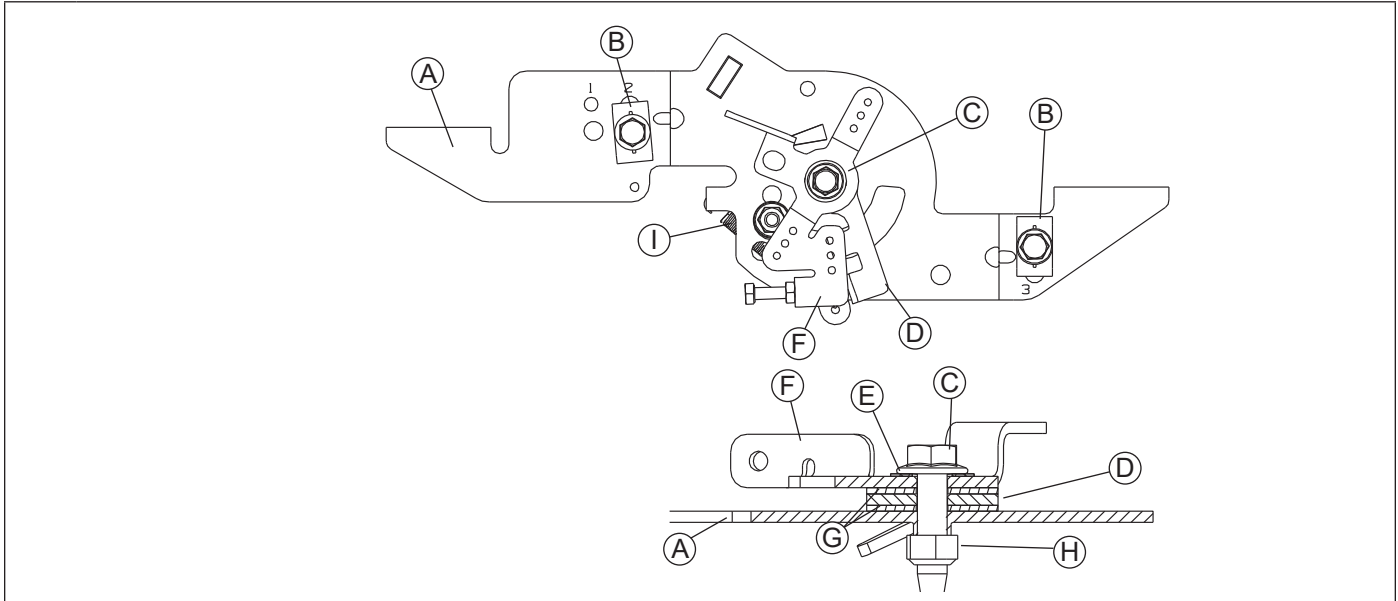

A	Speed Control Bracket	B	Cable Clamp	C	Screw	D	Throttle Actuator Lever (bottom)
E	Spring Washer	F	Throttle Control Lever (top)	G	Flat Washer	H	Nut
I	Return Spring						

Vaporizer/Regulator/Lock-Off Assembly

	⚠ WARNING	<p>Propane is extremely flammable and is heavier than air and tends to settle in low areas where a spark or flame could ignite gas. Do not start or operate this engine in a poorly ventilated area where leaking gas could accumulate and endanger safety of persons in area.</p>
	<p>Explosive Fuel can cause fires and severe burns. If a gaseous odor is detected, ventilate area and contact an authorized service technician.</p>	<p>To ensure personal safety, installation and repair of propane fuel supply systems must be performed only by qualified propane system technicians. Improperly installed and maintained propane equipment could cause fuel supply system or other components to malfunction, causing gas leaks.</p> <p>Observe federal, state and local laws governing propane fuel, storage, and systems.</p>

Remove Vaporizer/Regulator/Lock-Off

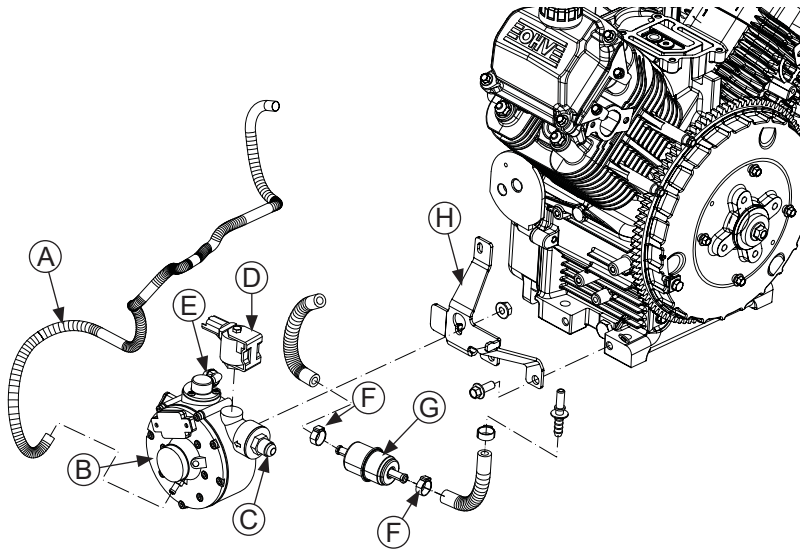

A	Vacuum Line	B	Vaporizer/Regulator	C	Inlet Fitting	D	Lock-Off Assembly
E	Outlet Fitting	F	Oetiker Clamp	G	Propane Fuel Filter	H	Bracket

1. Disconnect electrical plug from lock-off.
2. Disconnect vacuum line from front of vaporizer/regulator.
3. Loosen nut on center back of vaporizer/regulator. Keep all fuel lines connected, then lift up on regulator so nut comes through key hole slot in bracket, removing vaporizer/regulator from bracket (keeping fuel lines, propane fuel filter assembled).
Separate parts only if additional service is required. Do not cut Oetiker clamps unless fuel lines and/or propane fuel filter are being replaced.
4. Remove screws securing regulator bracket to crankcase.

Remove Throttle Body

1. On earlier engines with separate intake air temperature (IAT) and MAP sensors, disconnect IAT sensor from throttle body. Sensor can stay in throttle body unless it is being replaced.
2. Disconnect breather tube from throttle body.
3. Disconnect throttle position sensor connector.
4. Disconnect vent hose from throttle body.
5. Remove screws securing air cleaner bracket, take off bracket and slide throttle body (with linkage and spring connected) off intake manifold.

Disassembly/Inspection and Service

ECU

Remove Electronic Control Unit (ECU)

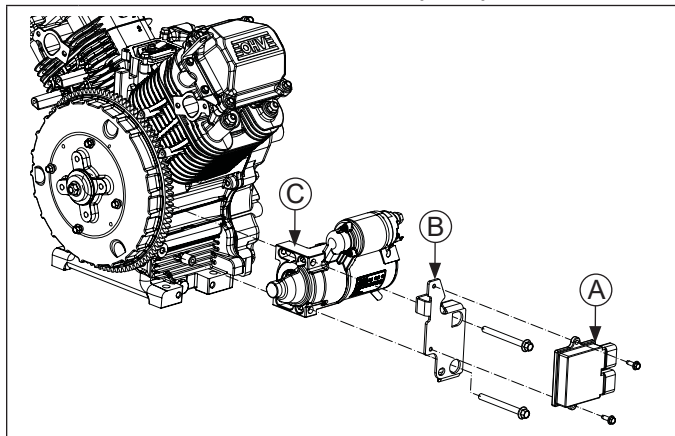

A	Electronic Control Unit (ECU)	B	ECU Bracket
C	Starter		

1. Remove screws securing ECU to bracket.
2. Disconnect Black and Grey electrical connectors from ECU.

Remove Electronic Control Unit Bracket and Electric Starter Motor

1. Disconnect leads from starter.
2. Remove screws, ECU bracket, and starter assembly.

Remove Guard and Debris Screen

NOTE: Fan will be loose, but cannot be removed until after blower housing is removed.

1. Remove screws securing guard to blower housing and remove guard and spacers.
2. Remove screws securing metal screen and remove screen.
3. Remove support ring, spacers, and washers paying attention to curvature of spring washers between spacers and fan.

Remove Outer Barrel Baffles, Debris Screen, and Blower Housing

1. Disconnect plug from rectifier-regulator.
2. Remove silver or green plated rectifier-regulator ground strap/ground lead screw fastened to crankcase. Rectifier-regulator does not have to be detached from blower housing.
3. Disconnect 3 fuse connectors on outer baffle and allow them to hang.
4. Remove screws securing outer barrel baffles. Note location of any lifting strap and position of short screws for reassembly. Coil and any hoses may remain attached to baffle after being unplugged or disconnected.
5. Remove outer barrel baffles.
6. If debris screen overlaps blower housing, remove fasteners and screen.

7. Remove remaining screws securing blower housing. Remove blower housing.
8. Remove cooling fan.

Remove Oil Sentry™ (If Equipped)

NOTE: This is optional. Removing Oil Sentry™ is not required to remove breather cover.

1. Disconnect lead from Oil Sentry™ switch.
2. Remove Oil Sentry™ switch from breather cover.

Remove Oil Temperature Sensor

NOTE: Unless oil temperature sensor is damaged or malfunctioning, disassembly from breather cover is unnecessary.

1. Disconnect lead from oil temperature sensor.
2. Remove oil temperature sensor from breather cover.

Remove Inner Baffles and Breather Cover

NOTE: Removing oil temperature sensor is not required to remove breather cover or inner baffles.

1. Remove screws securing inner baffles to crankcase.
2. Remove inner (valley) baffles.
3. Disconnect and remove oil temperature sensor.
4. Remove remaining screws from breather cover.
5. Pry under protruding edge of breather cover with a screwdriver to break gasket seal. Do not pry on sealing surfaces as it could cause damage resulting in leaks.
6. Remove breather cover and gasket.

Remove Crankshaft Position Sensor

1. Remove screws securing crankshaft position sensor bracket.
2. Disconnect electrical connector from crankshaft position sensor.

Remove Manifold Absolute Pressure (MAP) Sensor or Temperature/Manifold Absolute Pressure (TMAP) Sensor

1. With a screwdriver, slide locking tab on electrical connector.
2. Detach connector.
3. Remove screw and pull MAP or TMAP sensor out of intake manifold.

Remove Fuel Injectors

1. Disconnect electrical connector.
2. Remove screw and pull injector out of intake manifold for each injector.
3. When removed, pull metal retaining clip connecting fuel injector to fuel injector cap. There may be some fuel left in line. Any spilled fuel must be cleaned up immediately.

Remove Intake Manifold

1. Remove screw securing a ring terminal which is part of wiring harness.
2. Remove screws securing intake manifold to cylinder heads. Note which screws hold wiring clamp.
3. Unclasp wiring harness from clip using a screwdriver.
4. Remove intake manifold and intake manifold gaskets.
5. Leave high pressure fuel line and wiring harness attached to manifold.

Cylinder Head Components

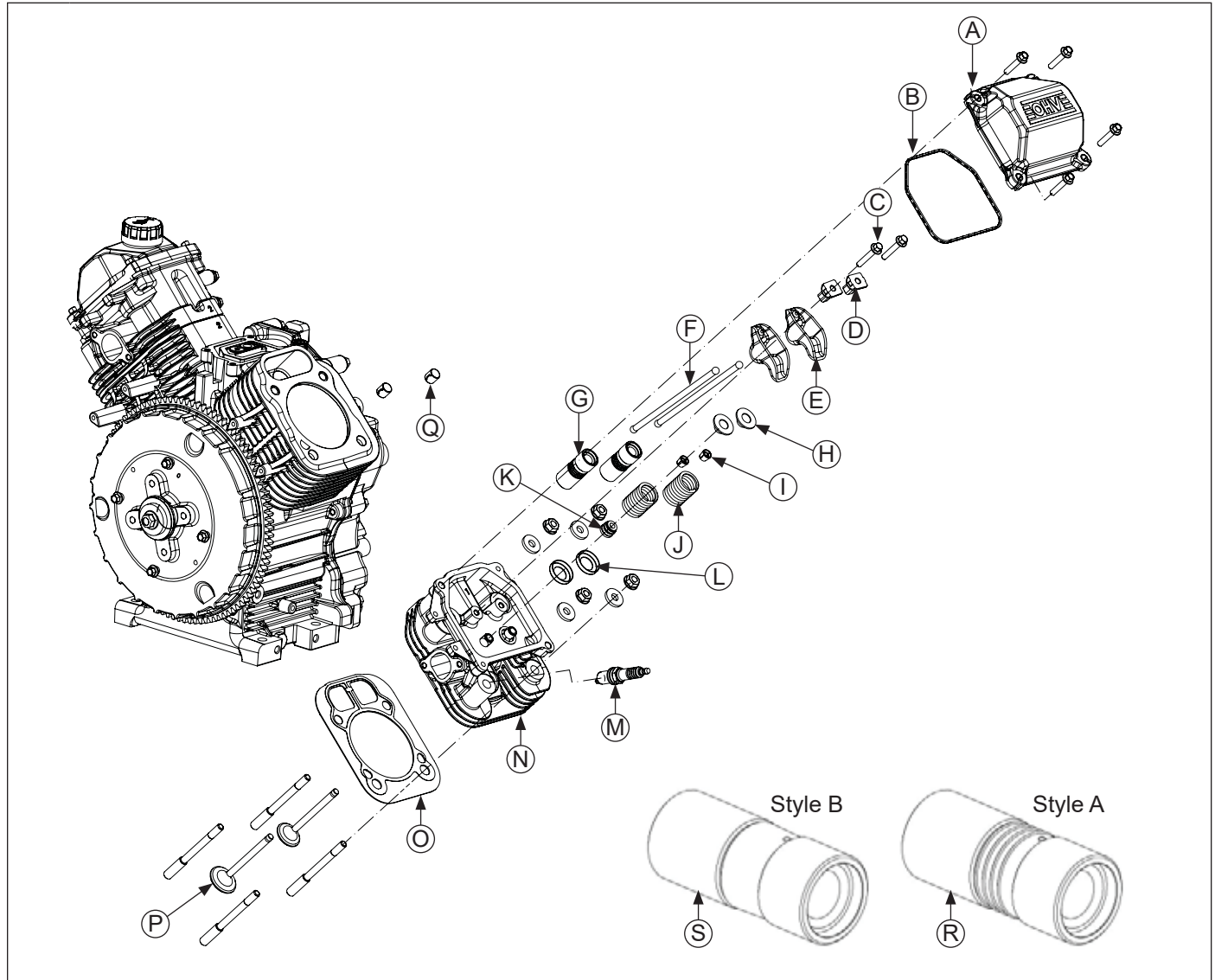

A	Valve Cover	B	Valve Cover O-ring	C	Hex Flange Screw	D	Rocker Arm Pivot
E	Rocker Arm	F	Push Rod	G	Hydraulic Lifter	H	Valve Cap
I	Valve Keeper	J	Valve Spring	K	Valve Seal	L	Valve Spring Retainer
M	Spark Plug	N	Cylinder Head	O	Cylinder Head Gasket	P	Valve
Q	Dowel Pin	R	Hydraulic Lifter Style A (Ribbed)	S	Hydraulic Lifter Style B (Smooth)		

Disassembly/Inspection and Service

Remove Valve Covers

1. Remove screws securing each valve cover. Note valve cover differences for proper location in reassembly. Ensure any brackets removed are reassembled in same location.
2. Covers should lift off without prying.

Remove Spark Plugs

Remove spark plug from each cylinder head.

Remove Cylinder Heads and Hydraulic Lifters

1. Remove nuts and washers securing each cylinder head. Discard nuts and washers once removed. Do not reuse. Studs (if present) should only be removed if damaged or if cylinder reconditioning is necessary. Once removed, they must be replaced.
2. Mark location of push rods as either intake or exhaust and cylinder 1 or 2. Push rods should always be reinstalled in same positions.
3. Carefully remove push rods, cylinder heads, and head gaskets.
4. Remove lifters from lifter bores. Use a hydraulic lifter tool. Do not use a magnet to remove lifters. Mark lifters by location, as either intake or exhaust, and cylinder 1 or 2. Hydraulic lifters should always be reinstalled in same position.

Inspection

Check base surface of hydraulic lifters for wear or damage. If lifters need to be replaced, apply a liberal coating of Rehlko lubricant (see Tools and Aids) to base of each new lifter before it is installed.

Bleeding Lifters Style A (Ribbed)

To prevent a possible bent push rod or broken rocker arm, it is important to bleed any excess oil out of lifters before they are installed.

1. Cut a 50-75 mm (2-3 in.) piece from end of an old push rod and chuck it in a drill press.
2. Lay a rag or shop towel on table of drill press and place lifter, open end up, on towel.
3. Lower chucked push rod until it contacts plunger in lifter. Slowly pump plunger 2 or 3 times to force oil out of feed hole in side of lifter.

Bleeding Lifters Style B (Smooth)

To prevent a possible bent push rod or broken rocker arm, it is important to bleed any excess oil out of lifters before they are installed.

1. Lay a rag or shop towel on table of drill press. Place an 8 mm (5/16 in.) socket on towel with well end up, then place open end of lifter on socket. Ensure socket does not contact lifter ball surface.
2. Place some material, such as wood, plastic, or aluminum, on top of lifter to protect lifter finish.
3. Lower drill press chuck until it contacts material on lifter. Slowly pump lifter 2 or 3 times to force oil out of feed hole in side of lifter.

Disassemble Cylinder Heads

NOTE: These engines use valve stem seals on intake and exhaust valves. Use a new seal whenever valve is removed or if seal is deteriorated or damaged in any way. Never reuse an old seal.

1. Remove screws, rocker arm pivots and rocker arms from cylinder head. Note screw color for reassembly.
2. Compress valve springs using a valve spring compressor.
3. Once valve spring is compressed, remove valve spring keepers, then remove following items.
 - Valve spring retainers
 - Valve springs
 - Valve spring caps
 - Intake and exhaust valve (mark position)
 - Valve stem seals (intake and exhaust)
4. Repeat above procedure for other cylinder head. Do not interchange parts from one cylinder head to other.

Inspection and Service Valve Details

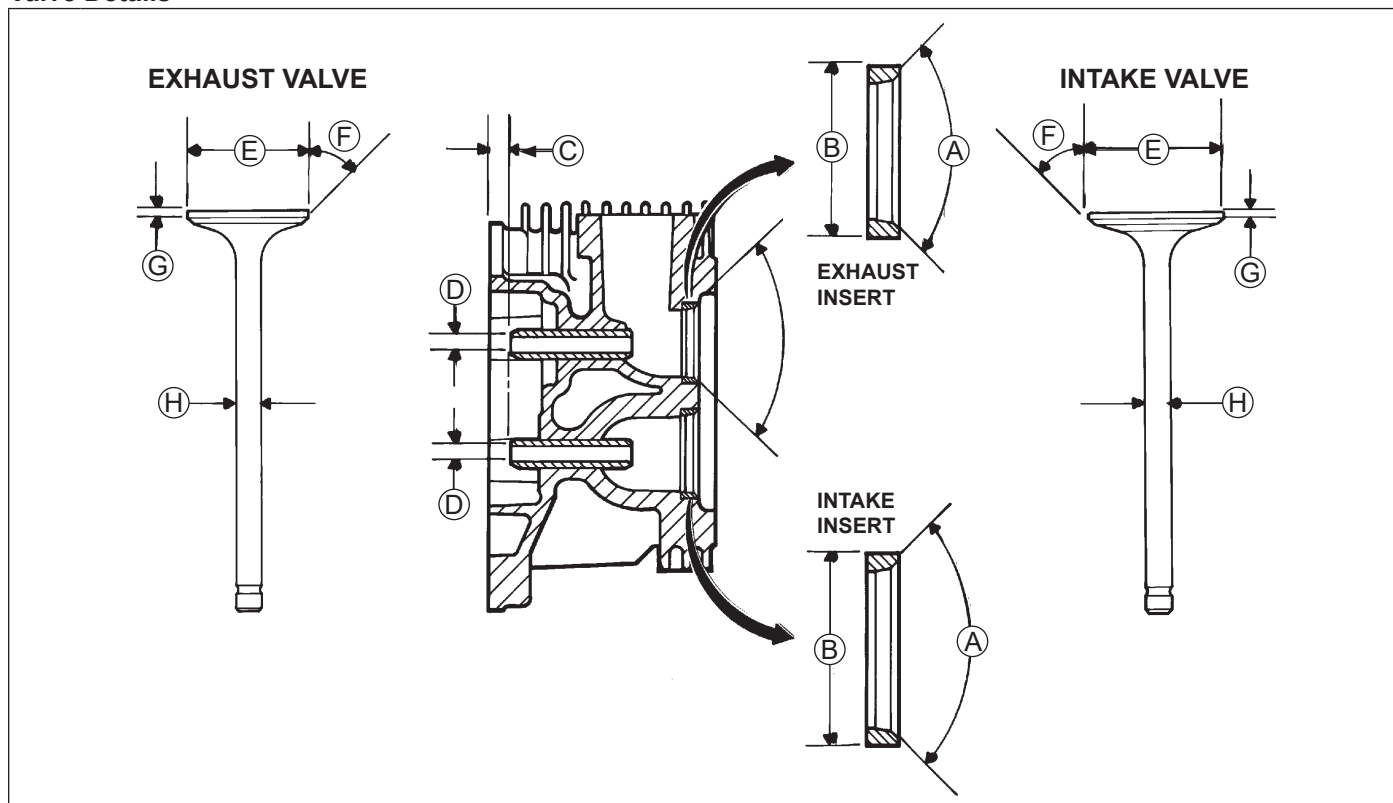

Dimension		Intake	Exhaust
A	Seat Angle	89°	89°
B	Insert O.D.	36.987/37.013 mm (1.4562/1.4572 in.)	32.987/33.013 mm (1.2987/1.2997 in.)
C	Guide Depth	4 mm (0.1575 in.)	6.5 mm (0.2559 in.)
D	Guide I.D.	7.038/7.058 mm (0.2771/0.2779 in.)	7.038/7.058 mm (0.2771/0.2779 in.)
E	Valve Head Diameter	33.37/33.63 mm (1.3138/1.3240 in.)	29.37/29.63 mm (1.1563/1.1665 in.)
F	Valve Face Angle	45°	45°
G	Valve Margin (Min.)	1.5 mm (0.0591 in.)	1.5 mm (0.0591 in.)
H	Valve Stem Diameter	6.982/7.000 mm (0.2749/0.2756 in.)	6.970/6.988 mm (0.2744/0.2751 in.)

After cleaning, check flatness of cylinder head and corresponding top surface of crankcase, using a surface plate or precision straight edge and feeler gauge. Maximum allowable out of flatness is 0.076 mm (0.003 in.).

Carefully inspect valve mechanism parts. Inspect valve springs and related hardware for excessive wear or distortion. Check valves and valve seat area or inserts for evidence of deep pitting, cracks, or distortion. Check clearance of valve stems in guides. See valve details and specifications.

Hard starting or loss of power accompanied by high fuel consumption may be symptoms of faulty valves. Although these symptoms could also be attributed to worn rings, remove and check valves first. After removal, clean valve heads, faces, and stems with a power wire brush. Then, carefully inspect each valve for defects such as a warped head, excessive corrosion, or a worn stem end. Replace valves found to be in bad condition.

Disassembly/Inspection and Service

Valve Guides

If a valve guide is worn beyond specifications, it will not guide valve in a straight line. This may result in burnt valve faces or seats, loss of compression, and excessive oil consumption.

To check valve guide-to-valve stem clearance, thoroughly clean valve guide and, using a split-ball gauge, measure inside diameter of guide. Then, using an outside micrometer, measure diameter of valve stem at several points on stem where it moves in valve guide. Use largest stem diameter to calculate clearance by subtracting stem diameter from guide diameter. If intake clearance exceeds 0.038/0.076 mm (0.0015/0.0030 in.) or exhaust clearance exceeds 0.050/0.088 mm (0.0020/0.0035 in.), determine whether valve stem or guide is responsible for excessive clearance.

Maximum (I.D.) wear on intake valve guide is 7.134 mm (0.2809 in.) while 7.159 mm (0.2819 in.) is maximum allowed on exhaust guide. Guides are not removable but can be reamed 0.25 mm (0.010 in.) oversize. Valves with 0.25 mm oversize stems must then be used.

If guides are within limits but valve stems are worn beyond limits, install new valves.

Valve Seat Inserts

Hardened steel alloy intake and exhaust valve seat inserts are press fitted into cylinder head. Inserts are not replaceable but can be reconditioned if not too badly pitted or distorted. If cracked or badly warped, cylinder head should be replaced.

Recondition valve seat inserts following instructions provided with valve seat cutter being used. Final cut should be made with an 89° cutter as specified for valve seat angle. Cutting proper 45° valve face angle as specified, and proper valve seat angle (44.5°, half of full 89° angle), will achieve desired 0.5° (1.0° full cut) interference angle where maximum pressure occurs on outside diameters of valve face and seat.

Lapping Valves

NOTE: Exhaust valves that are black in color cannot be ground and do not require lapping.

Reground or new valves must be lapped in, to provide proper fit. Use a hand valve grinder with a suction cup for final lapping. Lightly coat valve face with a fine grade of grinding compound, then rotate valve on its seat with grinder. Continue grinding until a smooth surface is obtained on seat and on valve face. Thoroughly clean cylinder head in soap and hot water to remove all traces of grinding compound. After drying cylinder head, apply a light coating of SAE 10 oil to prevent rusting.

Valve Stem Seal

These engines use valve stem seals on intake and exhaust valves. Always use a new seal when valves are removed from cylinder head. Seals should also be replaced if deteriorated or damaged in any way. Never reuse an old seal.

Flywheel Components

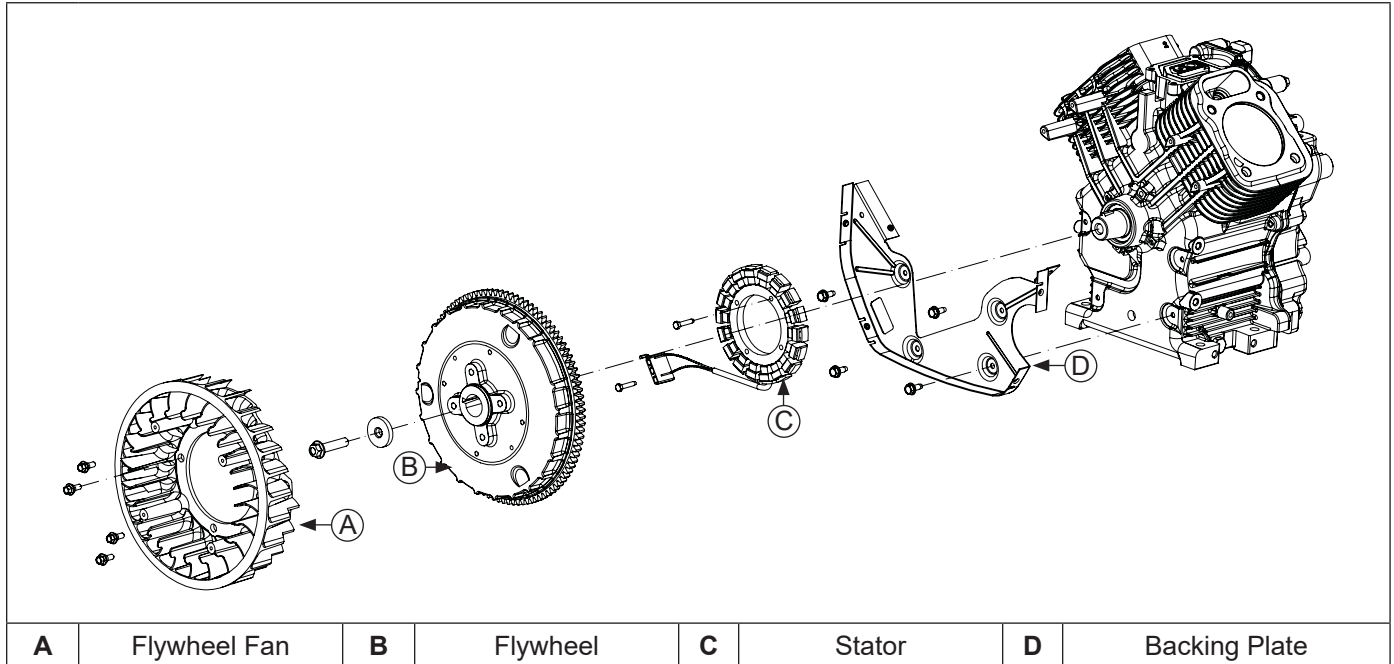

NOTE: Always use a flywheel strap wrench or holding tool to hold flywheel when loosening or tightening flywheel screw. Do not use any type of bar or wedge to hold flywheel. Use of such tools could cause flywheel to become cracked or damaged.

NOTE: Always use a flywheel puller to remove flywheel from crankshaft. Do not strike crankshaft or flywheel, as these parts could become cracked or damaged. Striking puller or crankshaft can cause crank gear to move, affecting crankshaft endplay.

1. Remove fan (screws were removed earlier with debris screen).
2. Use a flywheel strap wrench or holding tool (see Tools and Aids) to hold flywheel and loosen screw securing flywheel to crankshaft.
3. Remove screw and washer.
4. Use a puller to remove flywheel from crankshaft.
5. Remove woodruff key.

Inspection

Inspect flywheel for cracks and flywheel keyway for damage. Replace flywheel if it is cracked. Replace flywheel, crankshaft, and key if flywheel key is sheared or keyway is damaged.

Inspect ring gear for cracks or damage. Rehlko does not provide ring gear as a serviceable part. Replace flywheel if ring gear is damaged.

Remove Stator and Backing Plate

1. Remove screws securing backing plate. Remove backing plate.
2. Remove screws and stator. Note position/routing of stator lead.

Disassembly/Inspection and Service

Crankcase Components

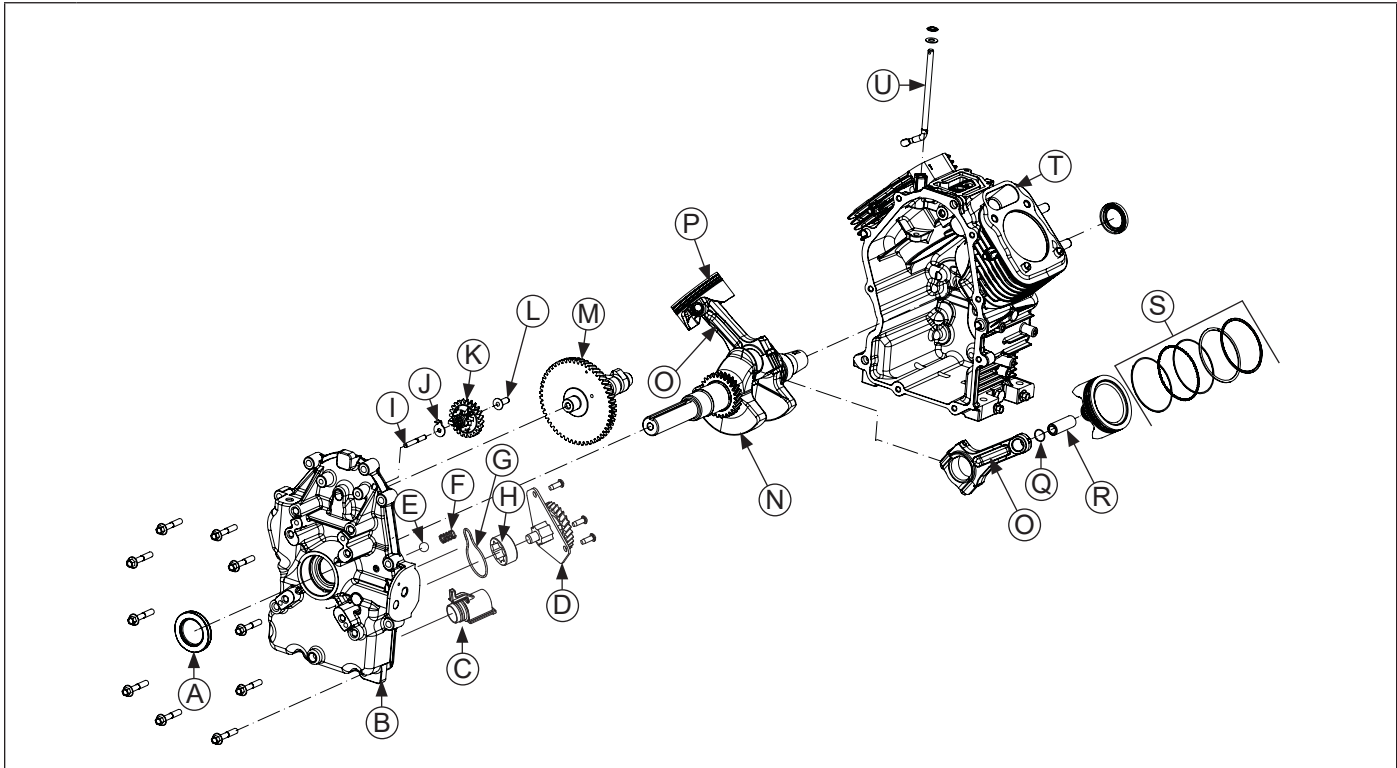

A	Closure Plate Seal	B	Closure Plate	C	Oil Pickup Tube	D	Oil Pump Assembly
E	Ball	F	Spring	G	Oil Pump Cover O-ring	H	Outer Gerotor Gear
I	Governor Shaft	J	Governor Washer	K	Governor Gear	L	Governor Cup
M	Camshaft	N	Crankshaft	O	Connecting Rod	P	Piston
Q	Piston Pin Retainer Clip	R	Piston Pin	S	Piston Rings	T	Crankcase
U	Governor Cross Shaft						

Remove Closure Plate Assembly

1. Remove screws securing closure plate to crankcase.
2. Locate splitting tabs cast into perimeter of closure plate. Insert drive end of a 1/2 in. breaker bar between splitting tab and crankcase and turn it to loosen seal. Do not pry on sealing surfaces as this can cause leaks.

Inspection

Inspect oil seal in closure plate and remove it if it is worn or damaged. Refer to Install Closure Plate Oil Seal in Reassembly for new oil seal installation.

Inspect main bearing surface for wear or damage (refer to Specifications). Replace closure plate assembly if required.

Governor Gear Assembly

Governor Shaft Press Depth Details

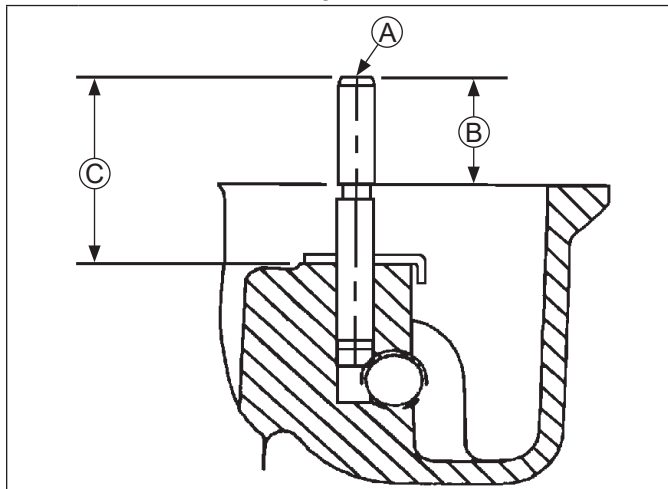

A	Gear Shaft
B	19.40 mm (0.7638 in.)
C	34.0 mm (1.3386 in.) 33.5 mm (1.3189 in.)

Governor gear assembly is located inside closure plate. If service is required, continue with Inspection, Disassembly, and Reassembly.

Inspection

Inspect governor gear teeth. Replace gear if it is worn, chipped, or if any teeth are missing. Inspect governor weights. They should move freely in governor gear.

Disassembly

NOTE: Governor gear is held onto shaft by small molded tabs in gear. When gear is removed from shaft, these tabs are destroyed and gear must be replaced. Therefore, remove gear only if absolutely necessary.

Governor gear must be replaced once it is removed from closure plate.

1. Remove regulating pin and governor gear assembly.
2. Remove locking tab thrust washer located under governor gear assembly.
3. Carefully inspect governor gear shaft and replace it only if it is damaged. After removing damaged shaft, press or lightly tap replacement shaft into closure plate to depth shown.

Reassembly

1. Install locking tab thrust washer on governor gear shaft with tab down.
2. Position regulating pin within governor gear/flyweight assembly and slide both onto governor shaft.

Oil Pump Assembly

Oil pump is mounted inside closure plate. If service is required, refer to Disassembly, Inspection, and Reassembly.

Disassembly

1. Remove screws.
2. Lift oil pump assembly from closure plate. Remove outer gerotor gear from closure plate.
3. Ensure ball and spring remain installed in pressure relief hole of closure plate. If ball and spring fall out of pressure relief hole, see reassembly for correct installation.
4. Remove oil pump cover O-ring from groove in closure plate.

Inspection

Inspect oil pump housing, gear, and rotors for nicks, burrs, wear, or any visible damage. Inspect oil pump cover O-ring for cuts, nicks, or any visible damage. If any parts are worn or damaged, replace oil pump assembly and/or O-ring. Check oil pickup screen for damage or restriction, replace if necessary.

Reassembly

1. Lubricate outer gerotor gear with oil. Install outer gerotor gear through shaft of oil pump, around inner gerotor gear. Matching molding dots on inner and outer gerotor gears is not necessary and will not affect oil pump efficiency.
2. Reinstall ball, then spring into pressure relief hole in closure plate.
3. Reinstall O-ring into groove in closure plate; make sure it is fully seated in groove.
4. Install oil pump inserting center shaft into corresponding recess in closure plate. Apply consistent downward pressure to oil pump cover, compressing oil pressure relief spring and start screws. Secure oil pump by torquing screws (in no specific sequence) to 9.0 N·m (80 in. lb.).
5. After torquing, rotate gear and check for freedom of movement. Make sure there is no binding. If binding occurs, loosen screws, reposition pump, retorque screws and recheck movement.

Remove Camshaft

Remove camshaft.

Inspection and Service

NOTE: To prevent repeat failures, camshaft and crankshaft should always be replaced as a set.

Check lobes of camshaft for wear or damage. See Specifications for minimum lift tolerances. Measurement must be performed while valve train is still assembled. Inspect cam gear for badly worn, chipped or missing teeth. Replacement of camshaft will be necessary if any of these conditions exist.

Disassembly/Inspection and Service

Remove Governor Cross Shaft

1. Remove retainer and nylon washer, from governor cross shaft.
2. Remove cross shaft through inside of crankcase.

Governor Cross Shaft Oil Seal

Cross Shaft Oil Seal Details

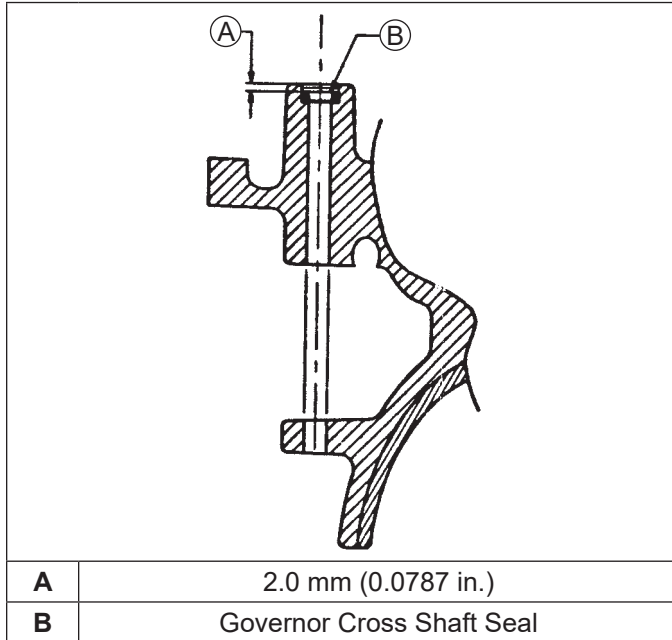

If governor cross shaft seal is damaged and/or leaks, replace it using these following procedures.

Remove oil seal from crankcase and replace it with a new one. Install new seal to depth shown using a seal installer.

Remove Connecting Rods with Pistons and Rings

NOTE: If a carbon ridge is present at top of either cylinder bore, use a ridge reamer tool to remove it before attempting to remove piston.

NOTE: Cylinders are numbered on crankcase. Use numbers to mark each end cap, connecting rod and piston for reassembly. Do not mix end caps and connecting rods.

1. Remove screws securing closest connecting rod end cap. Remove end cap.
2. Carefully remove connecting rod and piston assembly from cylinder bore.
3. Repeat above procedure for other connecting rod and piston assembly.
4. Remove piston pin from piston for inspection. Use a small screwdriver to pry pin retainer out of groove.

Inspection

Piston and Rings Components and Details

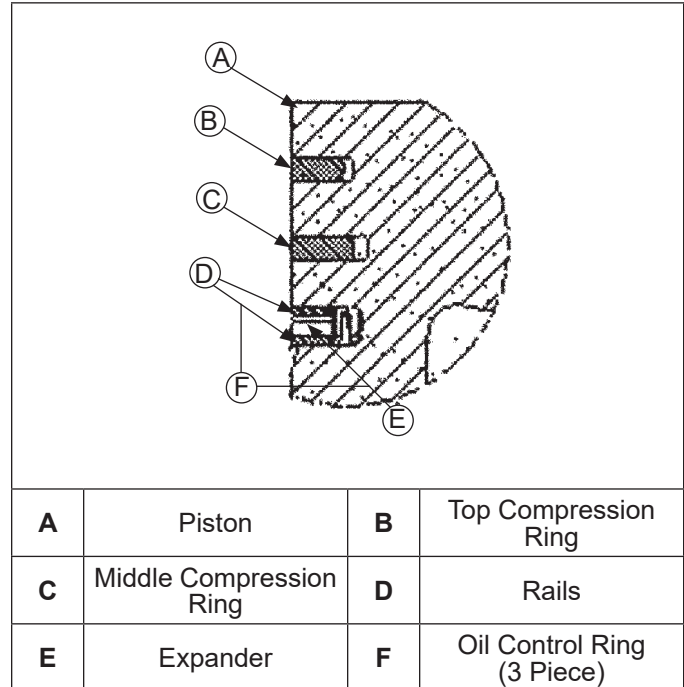

Scuffing and scoring of pistons and cylinder walls occurs when internal engine temperatures approach welding point of piston. Temperatures high enough to do this are created by friction, which is usually attributed to improper lubrication and/or overheating of engine.

Normally, very little wear takes place in piston boss-piston pin area. If original piston and connecting rod can be reused after new rings are installed, original pin can also be reused but new piston pin retainers are required. Piston pin is included as part of piston assembly – if pin boss in piston or pin are worn or damaged, a new piston assembly is required.

Ring failure is usually indicated by excessive oil consumption and blue exhaust smoke. When rings fail, oil is allowed to enter combustion chamber where it is burned along with fuel. High oil consumption can also occur when piston ring end gap is incorrect because ring cannot properly conform to cylinder wall under this condition. Oil control is also lost when ring gaps are not staggered during installation.

When cylinder temperatures get too high, lacquer and varnish collect on pistons causing rings to stick, which results in rapid wear. A worn ring usually takes on a shiny or bright appearance.

Scratches on rings and pistons are caused by abrasive material such as carbon, dirt, or pieces of hard metal.

Detonation damage occurs when a portion of fuel charge ignites spontaneously from heat and pressure shortly after ignition. This creates 2 flame fronts which meet and explode to create extreme hammering pressures on a specific area of piston. Detonation generally occurs from using low octane fuels.

Preignition or ignition of fuel charge before timed spark can cause damage similar to detonation. Preignition damage is often more severe than detonation damage. Preignition is caused by a hot spot in combustion chamber from sources such as glowing carbon deposits, blocked cooling fins, an improperly seated valve, or wrong spark plug(s).

Replacement pistons are available in STD bore size, and in 0.25 mm (0.010 in.), and 0.50 mm (0.020 in.) oversize. Replacement pistons include new piston ring sets and new piston pins.

Replacement ring sets are also available separately for STD, 0.25 mm (0.010 in.), and 0.50 mm (0.020 in.) oversize pistons. Always use new piston rings when installing pistons. Never use old rings.

Some important points to remember when servicing piston rings:

1. Cylinder bore must be deglazed before service ring sets are used.
2. If cylinder bore does not need reboring and if old piston is within wear limits and free of score or scuff marks, old piston may be reused.
3. Remove old rings and clean up grooves. Never reuse old rings.
4. Before installing new rings on piston, place top 2 rings, each in turn, in its running area in cylinder bore and check end gap. Compare ring gap to tolerance listed in Specifications.
5. After installing new compression (top and middle) rings on piston, check piston-to-ring side clearance. Compare clearance to tolerance listed in Specifications. If side clearance is greater than specified, a new piston must be used.

Install New Piston Rings

Piston Ring Orientation

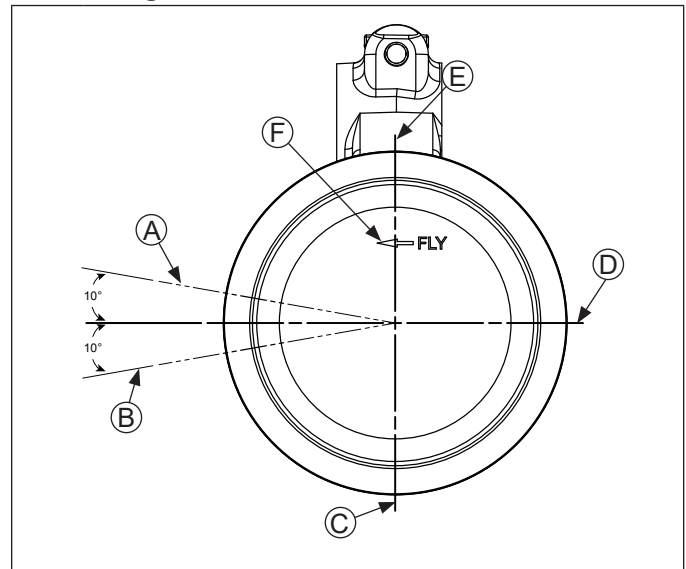

A	Top Oil Ring Rail Gap	B	Bottom Oil Ring Rail Gap
C	Intermediate Ring Gap	D	Oil Ring Expander Gap
E	Top Ring Gap	F	FLY Stamp

NOTE: Rings must be installed correctly. Ring installation instructions are usually included with new ring sets. Follow instructions carefully. Use a piston ring expander to install rings. Install bottom (oil control) ring first and top compression ring last.

To install new piston rings, proceed as follows:

1. Oil control ring (bottom groove): Install expander and then rails. Make sure ends of expander are not overlapped.
2. Middle compression ring (center groove): Install center ring using a piston ring installation tool. Make sure identification mark is up or colored dye stripe (if contained), is to left of end gap.
3. Top compression ring (top groove): Install top ring using a piston ring expander. Make sure identification mark is up or colored dye stripe (if contained), is to left of end gap.

Disassembly/Inspection and Service

Connecting Rods

Offset, stepped-cap connecting rods are used in all these engines.

Inspection and Service

Check bearing area (big end) for excessive wear, score marks, running and side clearances (refer to Specifications). Replace rod and cap if scored or excessively worn.

Service replacement connecting rods are available in STD crankpin size and 0.25 mm (0.010 in.) undersize. 0.25 mm (0.010 in.) undersized rod can be identified by drilled hole located in lower end of rod shank. Always refer to appropriate parts information to ensure correct replacements are used.

Remove Crankshaft

Carefully pull crankshaft from crankcase.

Inspection and Service

Crankshaft Components and Details

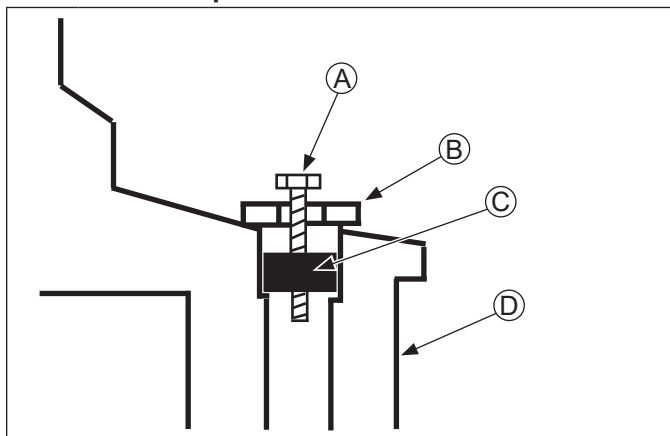

A	Self-Tapping Screw	B	Flat Washer
C	Plug	D	Crankshaft

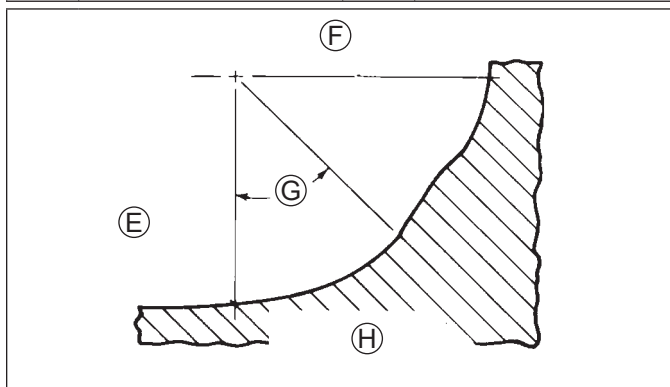

E	Fillet Must Blend Smoothly with Bearing Journal Surface
F	High Point from Fillet Intersections
G	45° Minimum
H	This Fillet Area Must Be Completely Smooth

NOTE: If crankpin is reground, visually check to ensure fillet blends smoothly with crankpin surface.

NOTE: To prevent repeat failures, camshaft and crankshaft should always be replaced as a set.

Inspect gear teeth of crankshaft. If teeth are badly worn, chipped, or some are missing, replacement of crankshaft will be necessary.

Inspect crankshaft bearing surfaces for scoring, grooving, etc. Some engines have bearing inserts in crankshaft bore of closure plate and/or crankcase. Do not replace bearings unless they show signs of damage or are out of running clearance specifications. If crankshaft turns easily and noiselessly, and there is no evidence of scoring, grooving, etc., on races or bearing surfaces, bearings can be reused.

Inspect crankshaft keyways. If they are worn or chipped, replacement of crankshaft will be necessary.

Inspect crankpin for score marks or metallic pickup. Slight score marks can be cleaned with crocus cloth soaked in oil. If wear limits, as stated in Specifications and Tolerances are exceeded, it will be necessary to either replace crankshaft or regrind crankpin to 0.25 mm (0.010 in.) undersize. If reground, a 0.25 mm (0.010 in.) undersize connecting rod (big end) must then be used to achieve proper running clearance. Measure crankpin for size, taper, and out-of-round.

Connecting rod journal can be ground one size under. When grinding a crankshaft, grinding stone deposits can get caught in oil passages, which could cause severe engine damage. Removing crankpin plug when crankshaft is ground provides easy access for removing any grinding deposits collected in oil passages.

Use these following procedures to remove and replace plug.

Procedure to Remove Crankshaft Plug:

1. Drill a 3/16 in. hole through plug in crankshaft.
2. Thread a 3/4 in. or 1 in. long self-tapping screw with a flat washer into drilled hole. Flat washer must be large enough to seat against shoulder of plug bore.
3. Tighten self-tapping screw until it draws plug out of crankshaft.

Procedure to Install New Plug:

Use a single cylinder camshaft pin, as a driver and tap plug into plug bore until it seats at bottom of bore. Make sure plug is tapped in evenly to prevent leakage.

Remove Flywheel End Oil Seal

Remove oil seal from crankcase.

Crankcase

Inspection and Service

Check all gasket surfaces to make sure they are free of gasket fragments. Gasket surfaces must also be free of deep scratches or nicks.

Inspect main bearing (if so equipped) for wear or damage (refer to Specifications). Replace crankcase using a miniblock or short block as required.

Check cylinder bore wall for scoring. In severe cases, unburned fuel can cause scuffing and scoring of cylinder wall. It washes necessary lubricating oils off piston and cylinder wall. As raw fuel seeps down cylinder wall, piston rings make metal to metal contact with wall. Scoring of cylinder wall can also be caused by localized hot spots resulting from blocked cooling fins or from inadequate or contaminated lubrication.

If cylinder bore is badly scored, excessively worn, tapered, or out-of-round, resizing is necessary. Use an inside micrometer to determine amount of wear (refer to Specifications), then select nearest suitable oversize of either 0.25 mm (0.010 in.) or 0.50 mm (0.020 in.). Resizing to one of these oversizes will allow usage of available oversize piston and ring assemblies. First, resize using a boring bar, then use these following procedures for honing cylinder.

Honing

Detail

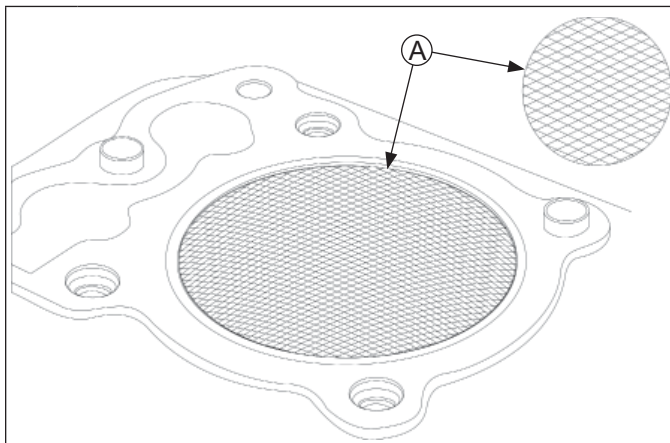

A 23°-33° Crosshatch

NOTE: Rehlko pistons are custom-machined to exacting tolerances. When oversizing a cylinder, it should be machined exactly 0.25 mm (0.010 in.) or 0.50 mm (0.020 in.) over new diameter (Specifications). Corresponding oversize Rehlko replacement piston will then fit correctly.

While most commercially available cylinder hones can be used with either portable drills or drill presses, use of a low speed drill press is preferred as it facilitates more accurate alignment of bore in relation to crankshaft crossbore. Honing is best accomplished at a drill speed of about 250 RPM and 60 strokes per minute. After installing coarse stones in hone, proceed as follows:

1. Lower hone into bore and after centering, adjust so stones are in contact with cylinder wall. Use of a commercial cutting-cooling agent is recommended.

2. With lower edge of each stone positioned even with lowest edge of bore, start drill and honing process. Move hone up and down while resizing to prevent formation of cutting ridges. Check size frequently.
3. When bore is within 0.064 mm (0.0025 in.) of desired size, remove coarse stones and replace them with burnishing stones. Continue with burnishing stones until bore is within 0.013 mm (0.0005 in.) of desired size and then use finish stones (220-280 grit) and polish bore to its final size. A crosshatch should be observed if honing is done correctly. Crosshatch should intersect at approximately 23°-33° off horizontal. Too flat an angle could cause rings to skip and wear excessively, and too steep an angle will result in high oil consumption.
4. After resizing, check bore for roundness, taper, and size. Use an inside micrometer, telescoping gauge, or bore gauge to take measurements. These measurements should be taken at 3 locations in cylinder – at top, middle, and bottom. Two measurements should be taken (perpendicular to each other) at each location.

Clean Cylinder Bore After Honing

Proper cleaning of cylinder walls following boring and/or honing is very critical to a successful overhaul. Machining grit left in cylinder bore can destroy an engine in less than 1 hour of operation after a rebuild.

Final cleaning operation should always be a thorough scrubbing with a brush and hot, soapy water. Use a strong detergent capable of breaking down machining oil while maintaining a good level of suds. If suds break down during cleaning, discard dirty water and start again with more hot water and detergent. Following scrubbing, rinse cylinder with very hot, clear water, dry it completely, and apply a light coating of engine oil to prevent rusting.

Disassembly/Inspection and Service

Measuring Piston-to-Bore Clearance

Piston Detail

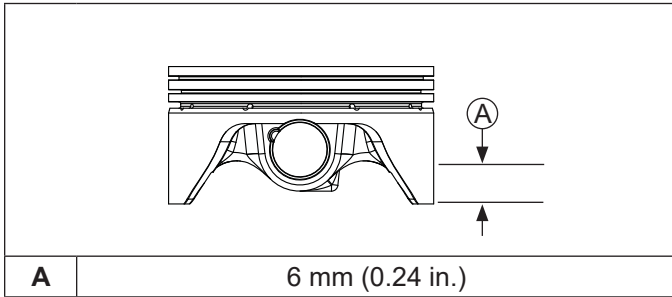

NOTE: Do not use a feeler gauge to measure piston-to-bore clearance – it will yield inaccurate measurements. Always use a micrometer.

Before installing piston into cylinder bore, it is necessary clearance be accurately checked. This step is often overlooked, and if clearances are not within specifications, engine failure will usually result.

Use these following procedures to accurately measure piston-to-bore clearance:

1. Use a micrometer and measure diameter of piston 6 mm (0.24 in.) above bottom of piston skirt and perpendicular to piston pin.
2. Use an inside micrometer, telescoping gauge, or bore gauge and measure cylinder bore. Take measurement approximately 63.5 mm (2.5 in.) below top of bore and perpendicular to piston pin.
3. Piston-to-bore clearance is difference between bore diameter and piston diameter (step 2 minus step 1).

Crankcase Components

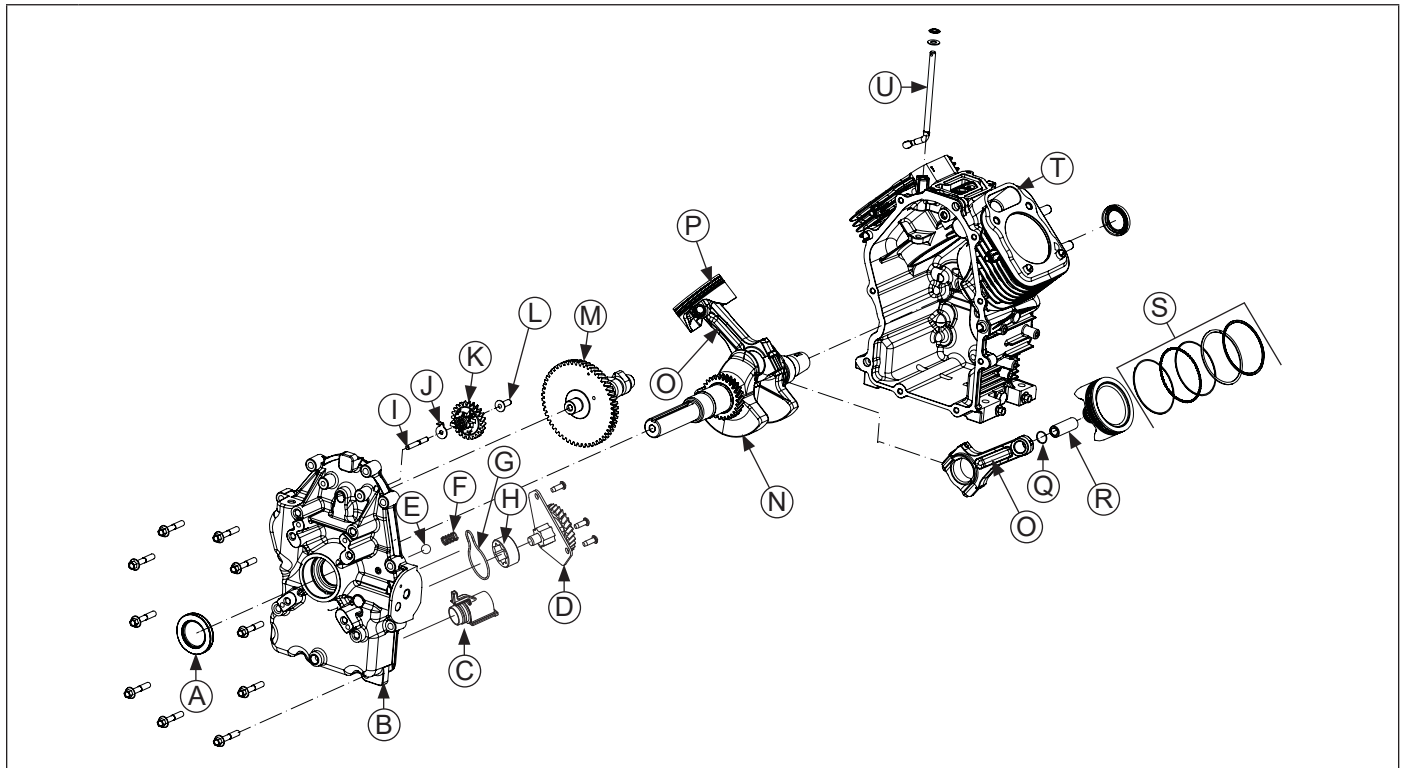

A	Closure Plate Seal	B	Closure Plate	C	Oil Pickup Tube	D	Oil Pump Assembly
E	Ball	F	Spring	G	Oil Pump Cover O-ring	H	Outer Gerotor Gear
I	Governor Shaft	J	Governor Washer	K	Governor Gear	L	Governor Cup
M	Camshaft	N	Crankshaft	O	Connecting Rod	P	Piston
Q	Piston Pin Retainer Clip	R	Piston Pin	S	Piston Rings	T	Crankcase
U	Governor Cross Shaft						

NOTE: Make sure engine is assembled using all specified torque values, tightening sequences, and clearances. Failure to observe specifications could cause severe engine wear or damage. Always use new gaskets. Apply a small amount of oil to threads of critical fasteners before assembly, unless a Sealant or Loctite® is specified or preapplied.

Make sure all traces of any cleaner are removed before engine is assembled and placed into operation. Even small amounts of these cleaners can quickly break down lubricating properties of engine oil.

Check closure plate, crankcase, and cylinder heads to be certain that all old sealing material has been removed. Use gasket remover, lacquer thinner, or paint remover to remove any remaining traces. Clean surfaces with isopropyl alcohol, acetone, lacquer thinner, or electrical contact cleaner.

Reassembly

Install Flywheel End Oil Seal

Oil Seal Detail

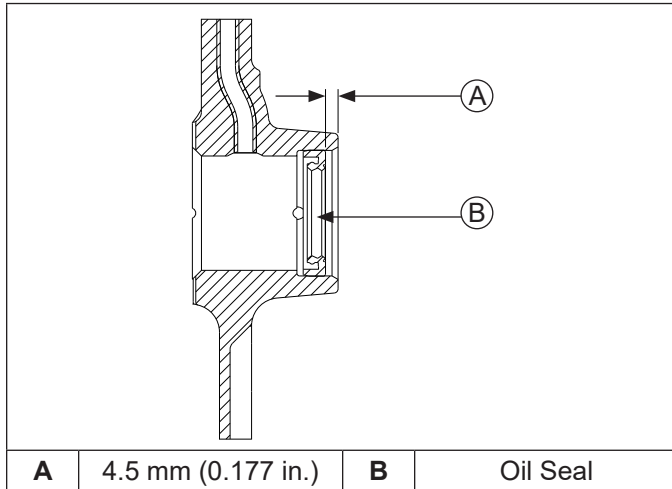

1. Make sure that seal bore of crankcase is clean and free of any nicks or burrs.
2. Apply a light coat of engine oil to outside diameter of oil seal.
3. Drive oil seal into crankcase using a seal driver. Make sure oil seal is installed straight and true in bore to depth shown.

Install Crankshaft

1. Lubricate crankshaft journals and connecting rod bearing surfaces with engine oil.
2. Carefully slide flywheel end of crankshaft through main bearing in crankcase.

Install Connecting Rods with Pistons and Rings

Piston Detail

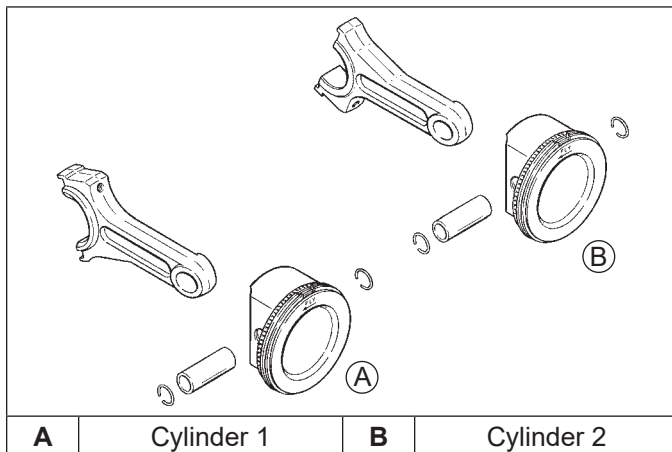

NOTE: Cylinders are numbered on crankcase. Make sure to install piston, connecting rod, and end cap into its appropriate cylinder bore as previously marked at disassembly. Do not mix end caps and connecting rods.

NOTE: Proper orientation of piston/connecting rod assemblies inside engine is extremely important. Improper orientation can cause extensive wear or damage. Be certain pistons and connecting rods are assembled exactly as shown.

NOTE: Align chamfer of connecting rod with chamfer of its mating end cap. When installed, flat faces of connecting rods should face each other. Faces with raised rib should be toward outside.

1. If piston rings were removed, see Disassembly/ Inspection and Service procedure to install new rings.
2. Lubricate cylinder bore, piston, and piston rings with engine oil. Compress rings using a piston ring compressor.
3. Make sure FLY stamping on piston is facing towards flywheel side of engine. Use a hammer with a rubber grip and gently tap piston into cylinder as shown. Be careful that oil ring rails do not spring free between bottom of ring compressor and top of cylinder.
4. Install inner rod cap to connecting rod using screws. Two different types of connecting rod screws have been used. If 6 mm straight shank, torque in increments to 11.6 N·m (103 in. lb.). If 6 mm straight shank gray metallic color, it is not necessary to lubricate this screw, torque in increments to 13.6 N·m (120 in. lb.). Illustrated instructions are provided in service rod package.
5. Repeat above procedure for other connecting rod and piston assembly.

Install Governor Cross Shaft

1. Lubricate governor cross shaft bearing surfaces in crankcase with engine oil.
2. Slide small lower washer onto governor cross shaft and install cross shaft from inside of crankcase.
3. Install nylon washer onto governor cross shaft, then start push-on retaining ring. Hold cross shaft up in position, place a 0.50 mm (0.020 in.) feeler gauge on top of nylon washer, and push retaining ring down shaft to secure. Remove feeler gauge, which will have established proper end play.

Install Camshaft

1. Liberally apply camshaft lubricant to each of cam lobes. Lubricate camshaft bearing surfaces of crankcase and camshaft with engine oil.
2. Position timing mark of crankshaft gear at 12 o'clock position.
3. Turn governor cross shaft clockwise until lower end of shaft contacts cylinder. Make sure cross shaft remains in this position while installing camshaft.
4. Slide camshaft into bearing surface of crankcase, positioning timing mark of camshaft gear at 6 o'clock position. Make sure camshaft gear and crankshaft gear mesh with both timing marks aligned.

Oil Pump Assembly

Oil pump is mounted inside closure plate. If service was required, and oil pump was removed, refer to assembly procedures under Oil Pump Assembly in Disassembly/Inspection and Service.

Governor Gear Assembly

Governor gear assembly is located inside closure plate. If service was required, and governor was removed, refer to assembly procedures under Disassembly/Inspection and Service.

Install Closure Plate Oil Seal

Oil Seal Details

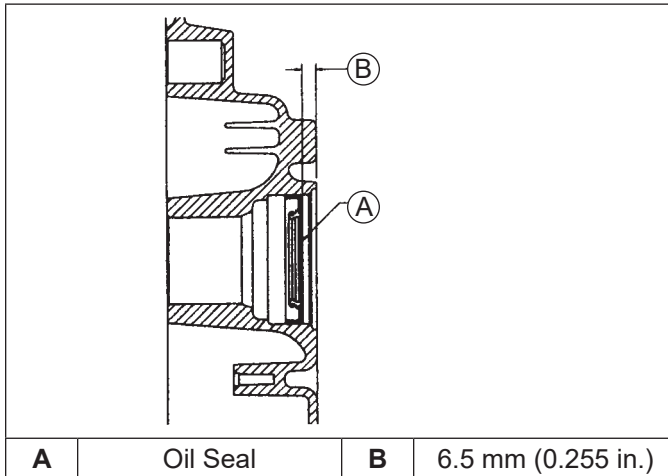

1. Check to make sure that there are no nicks or burrs in crankshaft bore of closure plate.
2. Apply a light coat of engine oil to outside diameter of oil seal.
3. Drive oil seal into closure plate using a seal driver. Make sure oil seal is installed straight and true in bore, to depth shown.

Install Closure Plate Assembly

Sealant Pattern and Torque Sequence

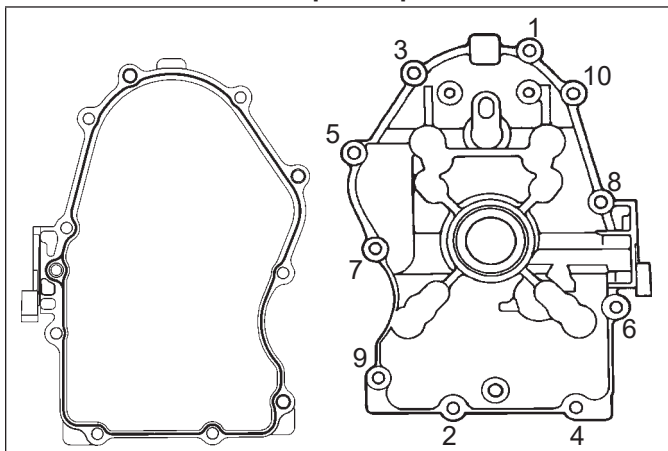

RTV sealant is used as a gasket between closure plate and crankcase. Always use fresh sealant. Using outdated sealant can result in leakage.

1. Be sure sealing surfaces have been cleaned and prepared.
2. Check to make sure there are no nicks or burrs on sealing surfaces of closure plate or crankcase.
3. Apply a 1.5 mm (1/16 in.) bead of sealant to sealing surface of closure plate.
4. Make sure end of governor cross shaft is lying against bottom of cylinder 1 inside crankcase.
5. Install closure plate to crankcase. Carefully seat camshaft and crankshaft into their mating bearings. Rotate crankshaft slightly to help engage oil pump and governor gear meshes.
6. Install screws securing closure plate to crankcase. Torque fasteners to 24.4 N·m (216 in. lb.) following sequence. On some engines one mounting screw is plated. Plated screw is typically installed in hole location 6.

Install Stator and Backing Plate

1. Apply pipe sealant with Teflon® (Loctite® 592™ PST® Thread Sealant or equivalent) to stator mounting holes.
2. Position stator aligning mounting holes so that leads are at bottom, towards crankcase.
3. Install and torque screws to 6.2 N·m (55 in. lb.) for new holes or 4.0 N·m (35 in. lb.) for used holes.
4. Route stator leads in crankcase channel, then install backing plate. Secure with screws. Torque screws 10.7 N·m (95 in. lb.) for new holes or 7.3 N·m (65 in. lb.) for used holes.

Install Flywheel

	⚠ CAUTION
	Damaging Crankshaft and Flywheel Can cause personal injury.
Using improper procedures can lead to broken fragments. Broken fragments could be thrown from engine. Always observe and use precautions and procedures when installing flywheel.	

Reassembly

Flywheel Components

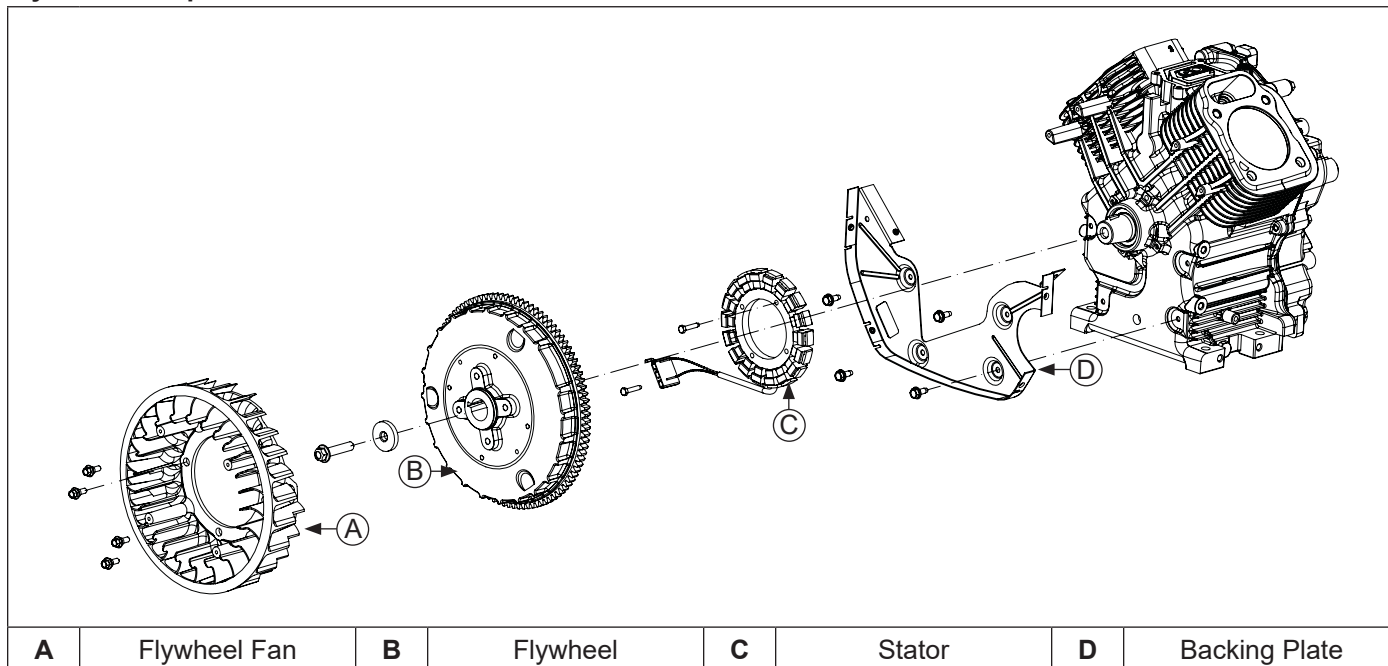

NOTE: Before installing flywheel, make sure crankshaft taper and flywheel hub are clean, dry, and completely free of any lubricants. Presence of lubricants can cause flywheel to be overstressed and damaged when screw is torqued to specifications.

NOTE: Make sure flywheel key is installed properly in keyway. Flywheel can become cracked or damaged if key is not properly installed.

1. Install woodruff key into keyway of crankshaft. Make sure that key is properly seated and parallel with shaft taper.
2. Install flywheel onto crankshaft being careful not to shift woodruff key.
3. Install screw and washer.
4. Use a flywheel strap wrench or holding tool to hold flywheel. Torque screw securing flywheel to crankshaft to 71.6 N·m (52.8 ft. lb.).

Install Fan

NOTE: Position locating tabs on back of fan into locating holes of flywheel.

1. Install fan onto flywheel using screws.
2. Torque screws to 9.9 N·m (88 in. lb.).

Cylinder Head Components

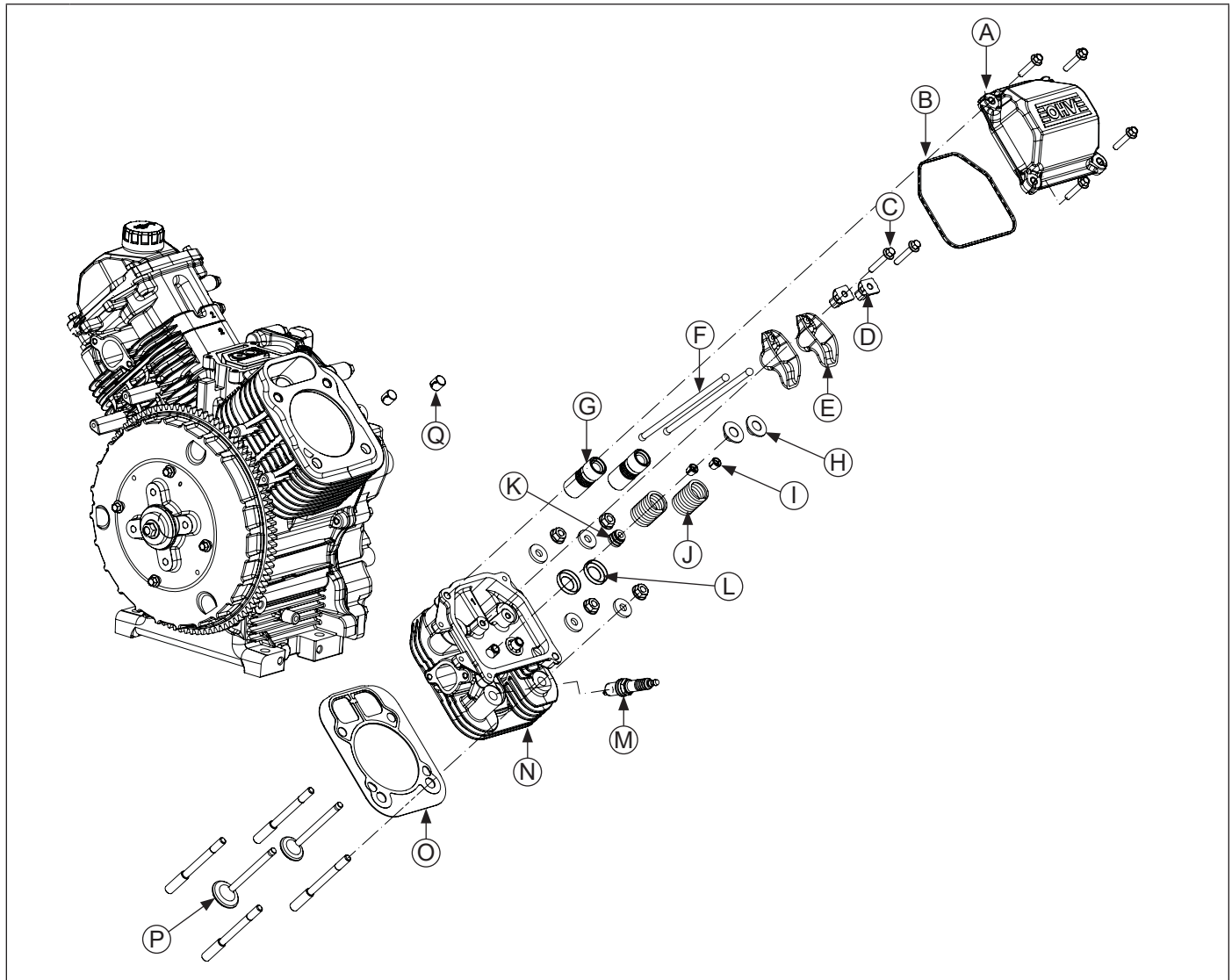

A	Valve Cover	B	Valve Cover O-ring	C	Hex Flange Screw	D	Rocker Arm Pivot
E	Rocker Arm	F	Push Rod	G	Hydraulic Lifter	H	Valve Cap
I	Valve Keeper	J	Valve Spring	K	Valve Seal	L	Valve Spring Retainer
M	Spark Plug	N	Cylinder Head	O	Cylinder Head Gasket	P	Valve
Q	Dowel Pin						

Install Hydraulic Lifters

NOTE: Hydraulic lifters should always be installed in same position as before disassembly. Exhaust lifters are located on output shaft (closure plate) side of engine while intake lifters are located on fan side of engine. Cylinder numbers are embossed on top of crankcase and each cylinder head.

1. See Servicing Hydraulic Lifters in Disassembly/ Inspection and Service.
2. Apply camshaft lubricant to bottom surface of each lifter. Lubricate hydraulic lifters and lifter bores in crankcase with engine oil.
3. Note mark or tag identifying hydraulic lifters as either intake or exhaust and cylinder 1 or 2. Install hydraulic lifters into their appropriate locations in crankcase. Do not use a magnet.
4. If breather reeds and stops were removed from crankcase, reinstall them at this time and secure with screw. Torque screw to 4.0 N·m (35 in. lb.).

Reassembly

Valve Stem Seals

These engines use valve stem seals on intake valves and on exhaust valves. Use a new seal whenever valve is removed or if seal is deteriorated or damaged in any way. Never reuse an old seal.

Assemble Cylinder Heads

Prior to installation, lubricate all components with engine oil, paying particular attention to lip of valve stem seal, valve stems, and valve guides. Install following items in order listed below using a valve spring compressor.

- Intake and exhaust valves.
- Valve spring retainers.
- Valve springs.
- Valve spring caps.
- Valve spring keepers.

Install Cylinder Heads

Torque Sequence

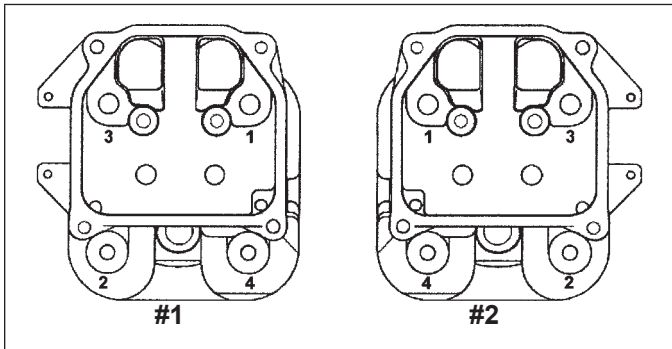

NOTE: Match numbers embossed on cylinder heads and crankcase.

1. Check to make sure there are no nicks or burrs on sealing surfaces of cylinder head or crankcase.
2. If all of studs were left intact, go to Step 6. If any studs were disturbed or removed, install new studs as described in Step 3. Do not use/reinstall any loosened or removed studs.
3. Install new mounting stud(s) into crankcase.
 - a. Thread and lock mounting nuts together on smaller diameter threads.
 - b. Thread opposite end of stud, with preapplied locking compound, into crankcase, until specified height from crankcase surface is achieved. When threading in studs, use a steady tightening motion without interruption until proper height is obtained. Otherwise frictional heat from engaging threads may cause locking compound to set up prematurely.

Studs closest to lifters must have an exposed height of 75 mm (2 15/16 in.).

Studs furthest from lifters must have an exposed height of 69 mm (2 3/4 in.).

- c. Remove nuts and repeat procedure as required.
4. Check that dowel pins are in place and install a new cylinder head gasket (part number facing up).
 5. Install cylinder head. Match numbers on cylinder heads and crankcase. Make sure head is flat on gasket and dowel pins.
 6. Lightly lubricate exposed (upper) threads of studs with engine oil. Install a flat washer and nut onto each of mounting studs. Torque nuts in 2 stages; first to 16.9 N·m (150 in. lb.), then finally to 33.9 N·m (300 in. lb.), following sequence.

Install Push Rods and Rocker Arms

NOTE: Push rods should always be installed in same position as before disassembly.

NOTE: Two different screws have been used to secure rocker arms/pivots. Black screws are used with heads that have a rocker pivot hole depth of approximately 21 mm (0.83 in.). Silver screws are used with heads that have a rocker pivot hole depth of approximately 35 mm (1.38 in.).

1. Note mark or tag identifying push rod as either intake or exhaust and cylinder 1 or 2. Dip ends of push rods in engine oil and install, making sure that each push rod ball seats in its hydraulic lifter socket.
2. Apply grease to contact surfaces of rocker arms and rocker arm pivots. Install rocker arms and rocker arm pivots on one cylinder head, and start screws.
3. Torque black screws to 18.1 N·m (160 in. lb.). Torque silver screws to 13.6 N·m (120 in. lb.).
4. Use a spanner wrench or rocker arm lifting tool to lift rocker arms and position push rods underneath.
5. Repeat above steps for remaining cylinder. Do not interchange parts from cylinder heads.
6. Rotate crankshaft to check for free operation of valve train. Check clearance between valve spring coils at full lift. Minimum allowable clearance is 0.25 mm (0.010 in.).

Check Assembly

Important: Rotate crankshaft a minimum of 2 revolutions to check longblock assembly and overall proper operation.

Install Spark Plugs

1. Check gap using wire feeler gauge. Adjust gap to 0.76 mm (0.030 in.).
2. Install plug into cylinder head.
3. Torque plug to 27 N·m (20 ft. lb.).

External Engine Components

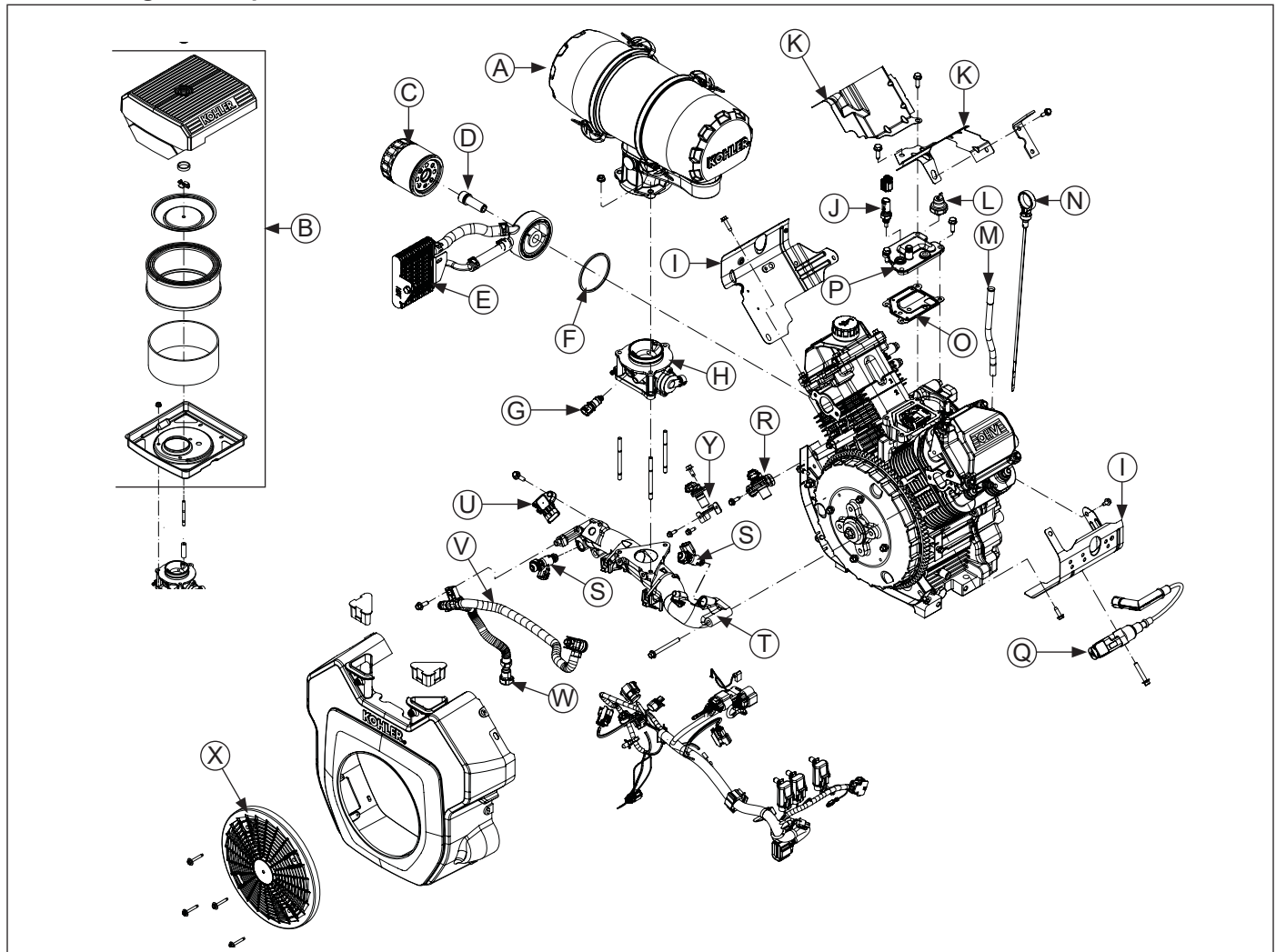

A	Heavy-Duty Air Cleaner	B	Low-Profile Air Cleaner	C	Oil Filter	D	Nipple
E	Oil Cooler	F	Oil Cooler O-Ring	G	Air Temperature Sensor	H	Throttle Body Assembly
I	Barrel Baffle	J	Oil Temperature Sensor	K	Valley Baffle	L	Oil Sentry™
M	Dipstick Tube	N	Dipstick	O	Breather Cover Gasket	P	Breather Cover
Q	Ignition Coil	R	Crankshaft Position Sensor (Earlier Design Bracket)	S	Gaseous Propane Fuel Injector	T	Intake Manifold
U	MAP or TMAP Sensor	V	High Pressure Fuel Line Assembly	W	Fuel Quick Connect	X	Debris Screen
Y	Crankshaft Position Sensor (Later Design Bracket)						

Reassembly

Install Intake Manifold

Torque Sequence

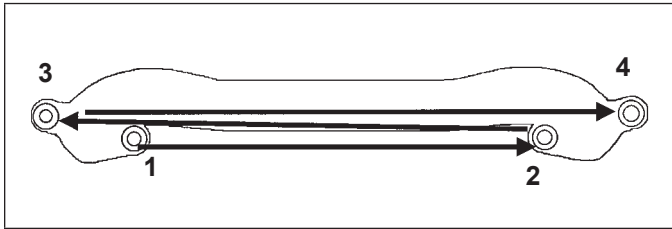

1. Install intake manifold (with high pressure fuel line assembly) and new gaskets, with wiring harness attached, to cylinder heads. Slide any wiring harness clips onto appropriate bolts before installing. Make sure gaskets are in proper orientation. Using sequence shown, torque screws in 2 stages, first to 7.8 N·m (69 in. lb.), then to 10.5 N·m (93 in. lb.).
2. Install ground terminal to crankcase post with a silver screw. Torque to 4.0 N·m (35 in. lb.) into used holes or 6.2 N·m (55 in. lb.) in new holes.
3. Install wire harness clip to other crankcase post. Torque to 4.0 N·m (35 in. lb.) into used holes or 6.2 N·m (55 in. lb.) in new holes.
4. Place wire harness conduit in clip and snap clip together.

Install Fuel Injectors

NOTE: Ensure all parts are clean, undamaged and free of debris and make sure electrical connectors have seal in place.

O-rings and retaining clips should be replaced any time fuel injector is separated from its normal mounting position.

1. Lightly lubricate fuel injector O-rings with clean engine oil.
2. Push retaining clip onto fuel injector, aligning clip.
3. Press fuel injector into fuel injector cap until retaining clip snaps into place.
4. Press fuel injector into bore in intake manifold and rotate to original position.
5. Install fuel injector cap screw into intake manifold and torque to 7.3 N·m (65 in. lb.).
6. Push electrical connector on fuel injector making sure a good connection is made.
7. Repeat steps 1 through 6 for other fuel injector.

Install Manifold Absolute Pressure (MAP) Sensor or Temperature/Manifold Absolute Pressure (TMAP) Sensor

NOTE: Ensure all parts are clean, undamaged and free of debris and make sure electrical connector has seal in place.

1. Lightly oil MAP or TMAP sensor O-ring and push sensor into bore in intake manifold.
2. Torque screw to 7.3 N·m (65 in. lb.).
3. Push electrical connector on MAP or TMAP sensor making sure a good connection is made.

Install Crankshaft Position Sensor

NOTE: Ensure all parts are clean, undamaged and free of debris and make sure electrical connectors have seal in place.

NOTE: On engines with earlier design bracket, an air gap must be set when installing. Later design brackets require no adjustment.

1. Install crankshaft position sensor and bracket assembly to crankcase posts.
2. On engines with earlier design bracket, snug screws and check air gap of sensor with a feeler gauge. It must be 0.20-0.70 mm (0.008-0.027 in.). Torque bracket screws to crankcase to 4.0 N·m (35 in. lb.) into used holes or 6.2 N·m (55 in. lb.) into new holes.
On engines with later design bracket, secure bracket assembly to crankcase posts. Torque bracket screws to crankcase to 4.0 N·m (35 in. lb.) into used holes or 6.2 N·m (55 in. lb.) into new holes.
3. Push electrical connector on crankshaft position sensor making sure a good connection is made.

Install Valve Covers

Torque Sequence

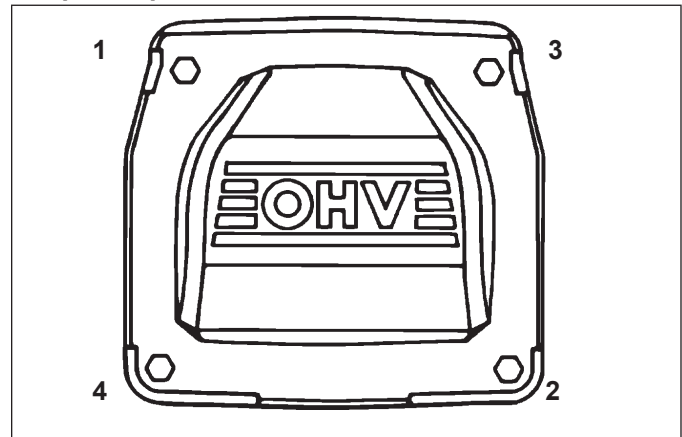

1. Make sure sealing surfaces are clean.
2. Make sure there are no nicks or burrs on sealing surfaces.
3. Install a new O-ring in groove of each cover.
4. Position covers on cylinder heads. Locate cover with oil separator hole on cylinder 1. Install screws in each cover and finger tighten.
5. Torque valve cover fasteners to 9.0 N·m (80 in. lb.).

Install Breather Cover and Inner Baffles

Torque Sequence

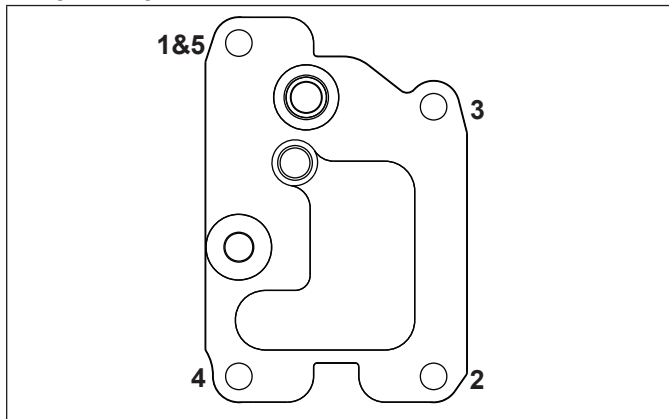

1. Be sure sealing surfaces of crankcase and breather cover are clean of old gasket material. Do not scrape surfaces as this could result in leakage. Use a new gasket when installing breather cover.
2. Check to make sure there are no nicks or burrs on sealing surfaces.
3. Position breather gasket and cover on crankcase. Install screws in locations 3 and 4. Finger tighten at this time.
4. Install inner baffles using remaining screws and finger tighten. Do not torque screws at this time; they will be tightened after blower housing.

Install Oil Temperature Sensor

NOTE: Ensure part is clean, undamaged and free of debris and make sure electrical connector has seal in place.

1. Lightly lubricate oil temperature sensor O-ring and install oil temperature sensor into breather cover.
2. Torque sensor to 7.3 N·m (65 in. lb.).
3. Push electrical connector on oil temperature sensor making sure a good connection is made.

Install Oil Sentry™ (If equipped)

1. Apply pipe sealant with Teflon® (Loctite® 592™ PST® Thread Sealant or equivalent) to threads of Oil Sentry™ switch and install it into breather cover. Torque to 4.5 N·m (40 in. lb.).
2. Connect wire lead (green) to Oil Sentry™ terminal.

Install Blower Housing, Outer Baffles, and Debris Screen

NOTE: Do not completely tighten screws until all items are installed to allow shifting for hole alignment.

1. Connect plug to key switch in blower housing (if equipped).
2. Slide blower housing into position over front edge of inner baffles. Start a few screws to hold it in place.
3. Position outer baffles and secure using M6 screws. Install M6 screws (20 mm long) into intake port side of cylinder heads, including any lifting strap. Install M6 screws (16 mm long) into exhaust port side of

cylinder head. Install short M5 screws (10 mm long) in upper mounting holes of outer baffles (into backing plate). Be sure any leads are routed out through proper offsets or notches, so they will not be pinched between blower housing and baffles.

4. Insert and tighten all remaining blower housing and baffle screws with exception of rectifier-regulator grounding bracket screw. Torque all blower housing and baffle M6 screws assembled into aluminum to 10.7 N·m (95 in. lb.) for a new hole, or 7.3 N·m (65 in. lb.) for a used hole. Torque all blower housing and baffle M5 screws assembled into sheet metal (backing plate) to 2.8 N·m (25 in. lb.) for new holes, or 2.3 N·m (20 in. lb.) for used holes.
5. If an overlapping style debris screen is used, attach it to flywheel fan. Torque screws to 2.2 N·m (20 in. lb.)
6. Torque breather cover screws to 11.3 N·m (100 in. lb.) into new holes or 7.3 N·m (65 in. lb.) into used holes in sequence shown. Note first screw is torqued a second time.

Install Reconnect Rectifier-Regulator

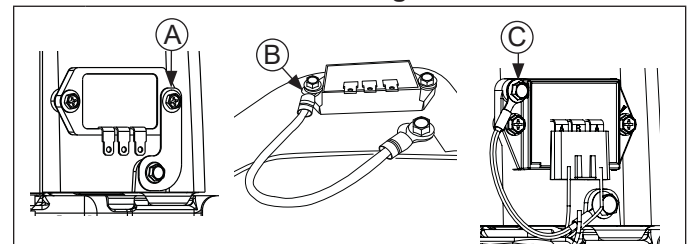

A	Ground Strap
B	Ground Lead
C	Ground Lug

NOTE: Rectifier-regulator middle terminal (B+) is offset (not equally spaced) from outer terminals (AC). Verify rectifier-regulator plug is assembled to match terminal offset of rectifier-regulator.

1. Install rectifier-regulator in blower housing if removed previously. Reinstall any washers and hose clamps.
 - a. If engine has ground strap, secure it against outer side of rectifier-regulator with a silver or green plated screw.
 - b. If engine has ground lead that secures in same hole as rectifier-regulator fastener, secure one end to rectifier-regulator and other end to backing plate.
 - c. If engine has ground lead that secures in separate ground lug fastener hole in rectifier-regulator, secure one end to ground lug and other end to backing plate.

Reassembly

2. Torque black rectifier-regulator screws to 1.4 N·m (12.6 in. lb.).
 - a. Torque silver or green ground strap screw to 2.8 N·m (25 in. lb.) into new holes or 2.3 N·m (20 in. lb.) into used holes.
 - b. Ground lead that secures in same hole as rectifier-regulator fastener, torque screw securing to backing plate to 2.8 N·m (25 in. lb.) into new holes or 2.3 N·m (20 in. lb.) into used holes.
 - c. Ground lead that secures in ground lug hole of rectifier-regulator and to backing plate, torque screws to 5.6 N·m (50 in. lb.) into new holes or 4.0 N·m (35 in. lb.) into used holes.
3. Connect plug to rectifier-regulator. If purple wire was removed, verify locking tang is raised on terminal and push wire terminal into plug prior to connecting to rectifier-regulator.

Install Electric Starter Motor and ECU Bracket

1. Install electric starter motor using screws. Position ECU bracket.
2. Torque screws to 16.0 N·m (142 in. lb.).
3. Connect leads to solenoid.
4. Install dipstick tube and align mounting hole with threaded hole in ECU bracket. Secure with M5 screw. Torque screw to 6.2 N·m (55 in. lb.) into new hole or 4.0 N·m (35 in. lb.) into used hole.

ECU

Install Electronic Control Unit (ECU)

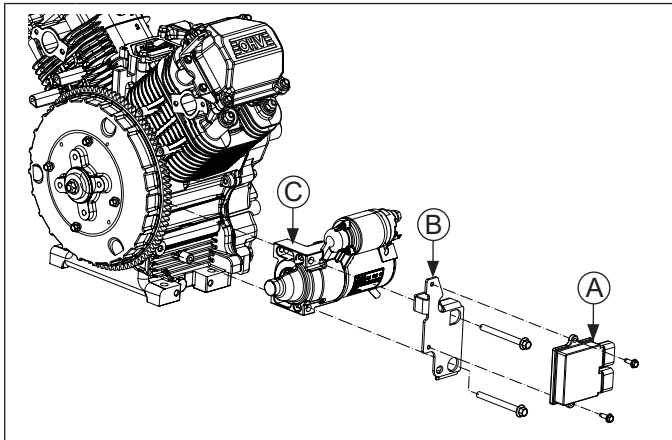

A	Electronic Control Unit (ECU)	B	ECU Bracket
C	Starter		

NOTE: ECU pins should be coated with a thin layer of electrical grease to prevent fretting and corrosion and may need to be reapplied if ECU is being reused.

1. Install ECU to ECU bracket using screws. Torque M5 screws to 6.2 N·m (55 in. lb.) into new holes or 4.0 N·m (35 in. lb.) into used holes.
2. Connect Black and Grey electrical connectors. Connectors and ECU are keyed in such a way so they cannot be installed incorrectly.

Install Throttle Body

NOTE: Ensure all parts are clean, undamaged and free of debris and make sure electrical connector has seal in place.

NOTE: Earlier engines have separate IAT and MAP sensors.

1. Install a new throttle body O-ring prior to installation. Make sure all holes align and are open.
2. Install throttle body, throttle position sensor, intake air temperature (IAT) sensor (earlier engines only), throttle linkage, spring and bushing, as an assembly.
3. Install air cleaner bracket to throttle body with screws. Torque screws to 9.9 N·m (88 in. lb.).
4. Connect breather separator hose to top of throttle body using a pliers to compress spring clip. Route hose through housing by pressing hose into cutout of blower housing. Position abrasion sleeve.
5. On earlier engines with separate intake air temperature (IAT) and MAP sensor, push electrical connector onto IAT sensor making sure a good connection is made by listening for a click.
6. Connect 5/32 in. I.D. vent hose to bottom of throttle body. (Other end of vent hose connects to vaporizer/regulator.)
7. Push electrical connector onto throttle position sensor making sure a good connection is made.

Install Vaporizer/Regulator/Lock-Off

	⚠ WARNING	<p>Propane is extremely flammable and is heavier than air and tends to settle in low areas where a spark or flame could ignite gas. Do not start or operate this engine in a poorly ventilated area where leaking gas could accumulate and endanger safety of persons in area.</p>
	<p>Explosive Fuel can cause fires and severe burns.</p> <p>If a gaseous odor is detected, ventilate area and contact an authorized service technician.</p>	<p>To ensure personal safety, installation and repair of propane fuel supply systems must be performed only by qualified propane system technicians. Improperly installed and maintained propane equipment could cause fuel supply system or other components to malfunction, causing gas leaks.</p> <p>Observe federal, state and local laws governing propane fuel, storage, and systems.</p>

Vaporizer/Regulator/Lock-Off Assembly

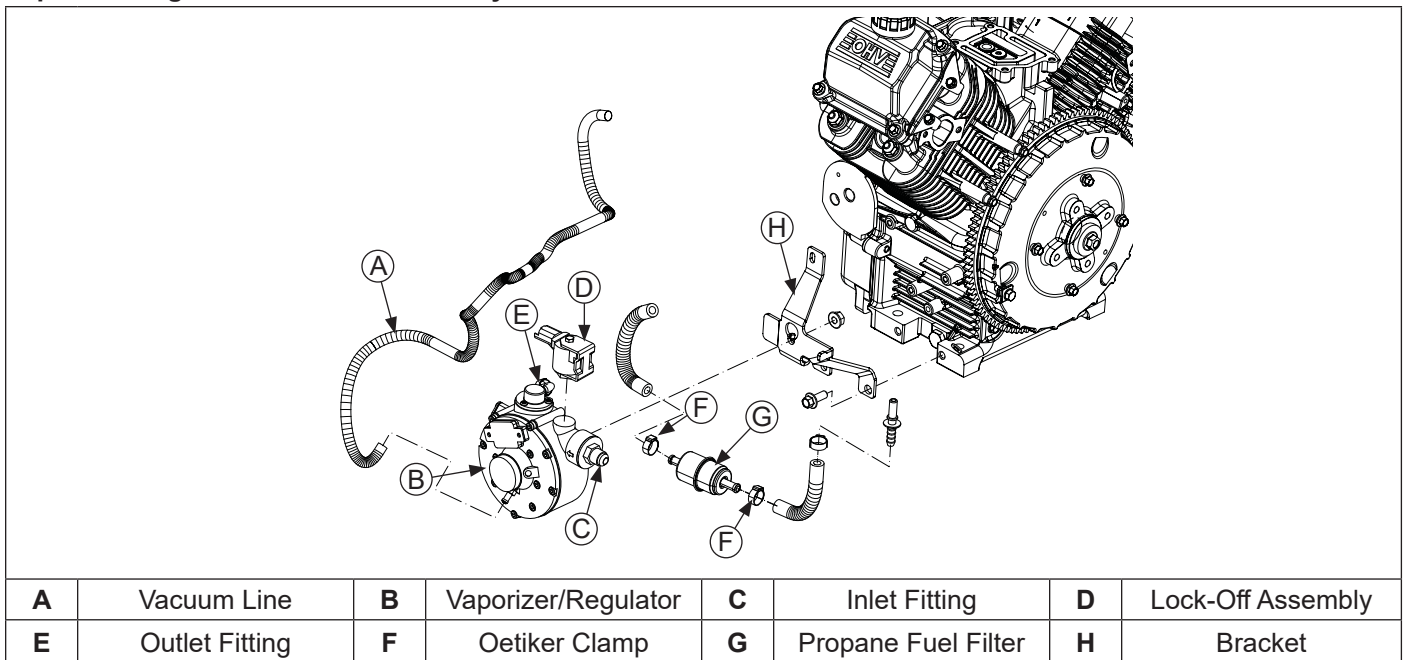

1. Connect fuel line quick connect (on high pressure fuel line assembly) to straight fitting (in fuel line after propane fuel filter).
2. Apply pipe sealant with Teflon® (Loctite® 592™ PST® Thread Sealant or equivalent) to regulator bracket screws, after first 3-4 lead-in threads. Install screws and secure regulator bracket to crankcase. Torque screws to 11.9 N·m (105 in. lb.). With nut installed on center back of vaporizer/regulator, position regulator so nut comes through key hole slot in bracket, installing vaporizer/regulator (keeping fuel lines, propane fuel filter assembled) to bracket. Torque nut to 19.8 N·m (175 in. lb.).
3. Connect vacuum line to barb on front of vaporizer/regulator.
4. Reconnect electrical plug to lock-off assembly.
5. If any Oetiker clamps were cut during disassembly, slide a new Oetiker clamp onto fuel line and connect fuel line. Only use an Oetiker clamp pliers to crimp Oetiker clamps. Oetiker clamp crimp must point up, away from top of vaporizer/regulator or propane fuel filter and abrasion sleeve must be positioned over Oetiker clamp.

Reassembly

Install External Governor Controls

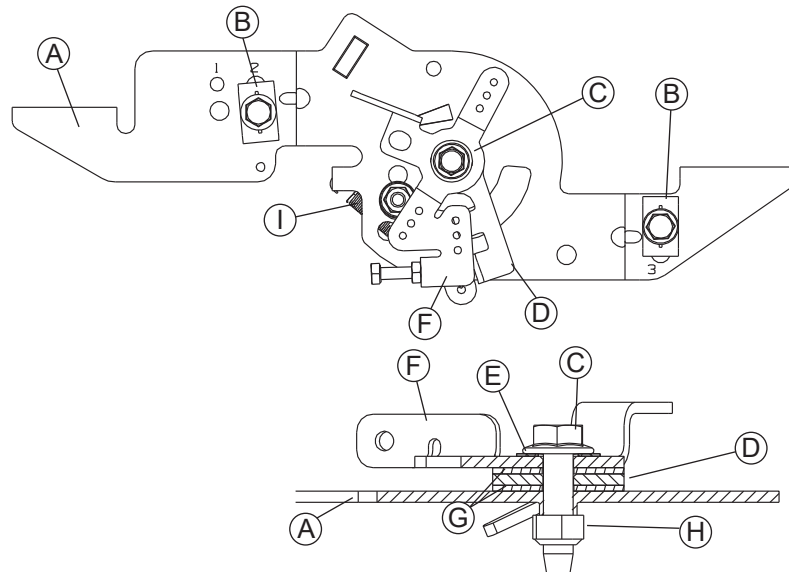

A	Speed Control Bracket	B	Cable Clamp	C	Screw	D	Throttle Actuator Lever (bottom)
E	Spring Washer	F	Throttle Control Lever (top)	G	Flat Washer	H	Nut
I	Return Spring						

1. Install governor lever onto governor cross shaft.
2. Make sure throttle linkage, linkage spring, black linkage bushing are connected to governor lever and to throttle lever on throttle body.

Assemble Top Mount Control Panel

1. Install lower support control bracket with throttle control shaft.
2. Install top mount control panel over throttle control shaft. Secure control panel to blower housing with screws.
3. Assemble throttle control lever and applicable hardware to throttle control shaft.
4. Attach governor spring to previously marked hole on governor lever.

Install Air Cleaner Assembly

Refer to Air Cleaner/Intake for air cleaner reassembly procedure.

Heavy-Duty Air Cleaner

1. Install air cleaner assembly onto throttle body mounting studs. Secure and torque nuts to 7.4-9.0 N·m (65.5-80 in. lb.).
2. Install and tighten two upper mounting screws securing air cleaner to mounting bracket. Torque screws to 9.9 N·m (88 in. lb.).

Low-Profile Air Cleaner

1. Verify O-ring is present around machined O.D. of throttle body and place air cleaner base onto throttle body studs. Secure air cleaner base using three nuts. Attach air cleaner base bracket to cylinder heads with screws behind any control panel or bracket. Attach air cleaner base to lower bracket with M5 screws through lower section of base. Torque nuts to 7.4-9.0 N·m (65.5-80 in. lb.), and lower M5 mounting screws to 2.3 N·m (20 in. lb.).
2. Install air cleaner components as described in Air Cleaner/Intake.

Setting Initial Governor Adjustment

1. Move governor lever toward throttle body as far as it will go (wide-open throttle) and hold in position.
2. Insert a nail into hole on cross shaft and rotate shaft counterclockwise as far as it will turn, then torque nut to 7.1 N·m (63 in. lb.).

Install Muffler

Oxygen Sensor Wire Detail

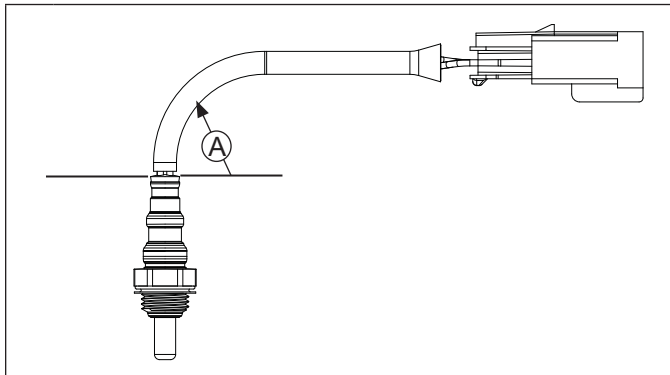

- | | |
|----------|--|
| A | Keep a minimum of 25 mm (1.0 in.) radius at grommet. |
|----------|--|

NOTE: Always route harness away from hot exhaust and away from moving parts.

1. Install port liners (if equipped), slotted end first, into exhaust ports until finger tight. (Exhaust components will press them to final depth.) Install exhaust gaskets and muffler. Install oxygen sensor, torque to 50.1 N·m (37 ft. lb.), and connect to wire harness.
2. Install remaining muffler support hardware (screws and nuts) and torque to 9.9 N·m (88 in. lb.).
3. Install nuts to exhaust studs. Torque nuts to 27.8 N·m (246 in. lb.).

Install Oil Cooler

1. Secure adapter to closure plate with oil filter nipple. Torque oil filter nipple to 28.5 N·m (21 ft. lb.).
2. Verify all fuel and vent hoses are routed properly and not pinched. Install screws to secure oil cooler to blower housing. Torque top screw to 2.8 N·m (25 in. lb.) and lower screw to 2.3 N·m (20 in. lb.).

Install Oil Filter and Fill Crankcase with Oil

NOTE: If testing oil pressure after completing reassembly, install oil pressure adapter instead of oil filter.

1. Prefill a new oil filter following instructions.
2. Place new filter in shallow pan with open end up. Fill with new oil until oil reaches bottom of threads. Allow 2 minutes for oil to be absorbed by filter material.
3. Apply a thin film of clean oil to rubber gasket on oil filter.
4. Refer to instructions on oil filter for proper installation.
5. Fill crankcase with new oil. Level should be at top of indicator on dipstick.
6. Reinstall oil fill cap/dipstick and tighten securely.

Connect Spark Plug Leads

1. Connect leads to spark plugs.

Prepare Engine for Operation

NOTE: If ECU or TPS/throttle body were replaced, an ECU Reset and TPS Learn is required. Refer to ECU Reset and TPS Learn procedures in Fuel System.

Engine is now completely reassembled. Before starting or operating engine, be sure to follow steps below.

1. Make sure all hardware is tightened securely.
2. Make sure oil drain plugs, Oil Sentry™ pressure switch, and a new oil filter are installed.
3. Fill crankcase with correct amount, weight, and type of oil. Refer to oil recommendations and procedures in Maintenance, Specifications, and Lubrication System.
4. Adjust idle speed adjusting screw as necessary. Refer to Fuel System.
5. Turn on fuel supply.

Reassembly

Sensitivity Adjustment

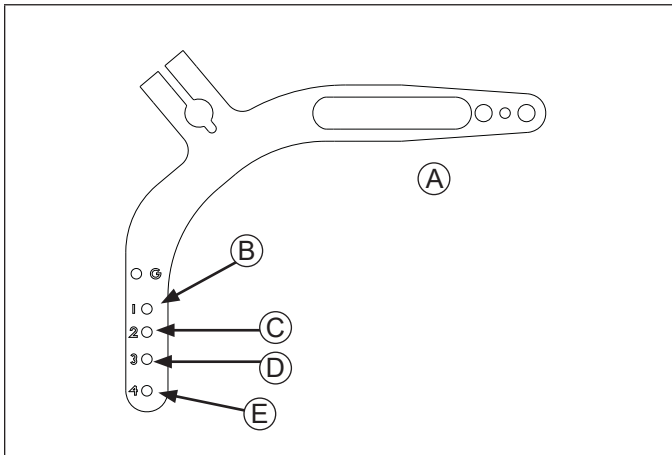

A	Governor Lever	B	Hole 1
C	Hole 2	D	Hole 3
E	Hole 4		

Governor sensitivity is adjusted by repositioning governor spring in holes of governor lever. If speed surging occurs with a change in engine load, governor is set too sensitive. If a big drop in speed occurs when normal load is applied, governor should be set for greater sensitivity. Adjust as follows:

1. To increase sensitivity, move spring closer to governor lever pivot point.
2. To decrease sensitivity, move spring away from governor lever pivot point.

Testing Engine

It is recommended engine be operated on a stand or bench prior to installation in piece of equipment.

1. Start engine, inspect for leaks and check to make certain that oil pressure (20 psi or more) is present. Run engine at idle for 2-3 minutes, then 5-6 minutes more between idle and midrange.
2. Adjust idle speed screw located on throttle body as necessary. Standard idle speed setting for EFI engines is 1500 RPM, but certain applications might require a different setting.
3. Adjust high-speed stop as necessary located on control panel (if equipped). Make sure maximum engine speed does not exceed 4200 RPM (no load).



1P24 690 32



8 85612 30912 9