

Command

CH18, CH20, CH23, CH25, CH640,
CH730, CH740

Liquefied Petroleum Gas (LPG), or LP/Natural Gas (NG) Fueled
Service Manual

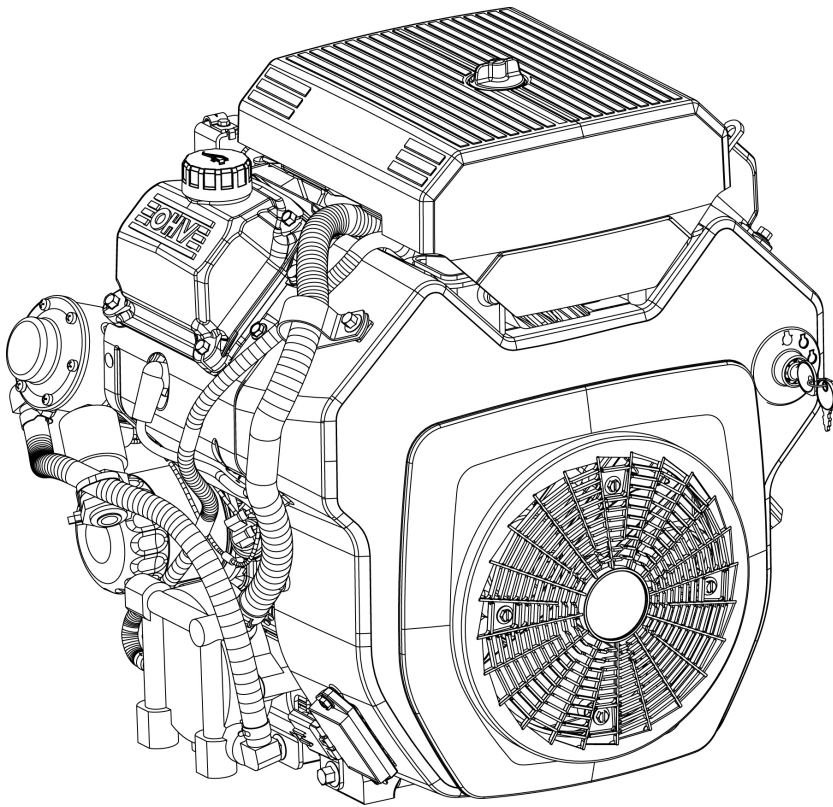

Kohler Engines
is now Rehlko.

2	Safety
3	Maintenance
5	Specifications
13	Tools and Aids
16	Troubleshooting
20	Air Cleaner/Intake
21	Fuel System
30	Governor System
32	Lubrication System
34	Electrical System
50	Starter System
57	Disassembly/Inspection and Service
73	Reassembly

IMPORTANT: Read all safety precautions and instructions carefully before operating equipment. Refer to operating instruction of equipment that this engine powers.

Ensure engine is stopped and level before performing any maintenance or service.

Safety

SAFETY PRECAUTIONS

⚠ WARNING: A hazard that could result in death, serious injury, or substantial property damage.

⚠ CAUTION: A hazard that could result in minor personal injury or property damage.

NOTE: is used to notify people of important installation, operation, or maintenance information.

	⚠ WARNING
	<p>Explosive Fuel can cause fires and severe burns.</p> <p>If a gaseous odor is detected, ventilate area and contact an authorized service technician.</p>
<p>LPG is extremely flammable and is heavier than air and tends to settle in low areas where a spark or flame could ignite gas. Do not start or operate this engine in a poorly ventilated area where leaking gas could accumulate and endanger safety of persons in area.</p> <p>NG is extremely flammable, is lighter than air, and rises. Do not start or operate this engine in a poorly ventilated area where leaking gas could accumulate and endanger safety of persons in area.</p> <p>To ensure personal safety, installation and repair of LPG/NG fuel supply systems must be performed only by qualified LPG/NG system technicians. Improperly installed and maintained LPG/NG equipment could cause fuel supply system or other components to malfunction, causing gas leaks.</p> <p>Observe federal, state and local laws governing LPG/NG fuel, storage, and systems.</p>	

	⚠ WARNING
	<p>Rotating Parts can cause severe injury.</p> <p>Stay away while engine is in operation.</p>
<p>Keep hands, feet, hair, and clothing away from all moving parts to prevent injury. Never operate engine with covers, shrouds, or guards removed.</p>	

	⚠ WARNING
	<p>Carbon Monoxide can cause severe nausea, fainting or death.</p> <p>Avoid inhaling exhaust fumes. Never run engine indoors or in enclosed spaces.</p>
<p>Engine exhaust gases contain poisonous carbon monoxide. Carbon monoxide is odorless, colorless, and can cause death if inhaled.</p>	

	⚠ WARNING
	<p>Accidental Starts can cause severe injury or death.</p> <p>Disconnect and ground spark plug lead(s) before servicing.</p>
<p>Before working on engine or equipment, disable engine as follows: 1) Disconnect spark plug lead(s). 2) Disconnect negative (-) battery cable from battery.</p> <p>Before disconnecting negative (-) ground cable, make sure all switches are OFF. If ON, a spark will occur at ground cable terminal which could cause an explosion if hydrogen gas or LPG/NG fuel vapors are present.</p>	

	⚠ WARNING
	<p>Hot Parts can cause severe burns.</p> <p>Do not touch engine while operating or just after stopping.</p>
<p>Never operate engine with heat shields or guards removed.</p>	

	⚠ WARNING
	<p>Cleaning Solvents can cause severe injury or death.</p> <p>Use only in well ventilated areas away from ignition sources.</p>
<p>Carburetor cleaners and solvents are extremely flammable. Follow cleaner manufacturer's warnings and instructions on its proper and safe use. Never use gasoline as a cleaning agent.</p>	

	⚠ CAUTION
	<p>Electrical Shock can cause injury.</p> <p>Do not touch wires while engine is running.</p>

	⚠ CAUTION
	<p>Damaging Crankshaft and Flywheel can cause personal injury.</p>
<p>Using improper procedures can lead to broken fragments. Broken fragments could be thrown from engine. Always observe and use precautions and procedures when installing flywheel.</p>	

	⚠ CAUTION
	<p>Failure to utilize or reassemble debris screen as designed could result in debris screen failure and serious personal injury.</p>

MAINTENANCE INSTRUCTIONS

	⚠ WARNING	Before working on engine or equipment, disable engine as follows: 1) Disconnect spark plug lead(s). 2) Disconnect negative (-) battery cable from battery.
	Accidental Starts can cause severe injury or death. Disconnect and ground spark plug lead(s) before servicing.	Before disconnecting negative (-) ground cable, make sure all switches are OFF. If ON, a spark will occur at ground cable terminal which could cause an explosion if hydrogen gas or LPG/NG fuel vapors are present.

Normal maintenance, replacement or repair of emission control devices and systems may be performed by any repair establishment or individual; however, warranty repairs must be performed by a Rehlko authorized dealer.

MAINTENANCE SCHEDULE

Every 25 Hours¹

<ul style="list-style-type: none"> Service precleaner element. 	Air Cleaner/Intake
---	--------------------

Every 100 Hours¹

<ul style="list-style-type: none"> Check oil cooler fins, clean as necessary (if equipped). 	Air Cleaner/Intake
<ul style="list-style-type: none"> Change oil. 	Lubrication System
<ul style="list-style-type: none"> Replace air cleaner element. 	Air Cleaner/Intake
<ul style="list-style-type: none"> Remove cooling shrouds and clean cooling areas. 	Air Cleaner/Intake

Every 200 Hours¹

<ul style="list-style-type: none"> Change oil filter. 	Lubrication System
--	--------------------

Every 300 Hours³

<ul style="list-style-type: none"> Change oil and filter (Xtended Life PRO 10W-50 oil and Xtended Life PRO filter only). 	Lubrication System
---	--------------------

Every 500 Hours or Annually¹ (whichever comes first)

<ul style="list-style-type: none"> Check all lines (high pressure/vacuum) including fittings for leaks. 	Fuel System
<ul style="list-style-type: none"> Drain regulator of accumulated fuel deposits. 	Fuel System
<ul style="list-style-type: none"> Replace spark plugs and set gap. 	Electrical System

Every 500 Hours or Annually^{1,2} (whichever comes first)

<ul style="list-style-type: none"> Have lock-off/filter serviced. 	Fuel System
--	-------------

Every 1500 Hours^{1,2}

<ul style="list-style-type: none"> Have regulator disassembled, cleaned, and reset. 	Fuel System
<ul style="list-style-type: none"> Have vaporizer disassembled, cleaned, and serviced. 	Fuel System

¹ Perform these procedures more frequently under severe, dusty, dirty conditions. ²

Must be performed by an authorized dealer or qualified LPG personnel only. ³

Option only if using Xtended Life PRO oil and Xtended Life PRO filter.

REPAIRS/SERVICE PARTS

Rehlko genuine service parts can be purchased from Rehlko authorized dealers. To find a local authorized dealer visit engines.rehlko.com or call 1-800-544-2444 (U.S. and Canada).

Maintenance

OIL RECOMMENDATIONS

All-season Xtended Life PRO 10W-50 Synthetic Oil is the ideal oil for Rehlko engines. It is specifically formulated to extend the oil and oil filter change interval to 300 Hours when paired with a Xtended Life PRO Oil Filter.

300-Hour oil and oil filter change intervals are exclusive to and only authorized on Rehlko engines that utilize both the Xtended Life PRO 10W-50 Synthetic Oil and Xtended Life Oil Filter. Alternative engine oils and oil filters may be used with Rehlko engines but require 100-Hour oil and 200-Hour oil filter change intervals for proper maintenance. Oil must be API (American Petroleum Institute) service class SJ or higher. Select viscosity based on air temperature at time of operation as shown below.

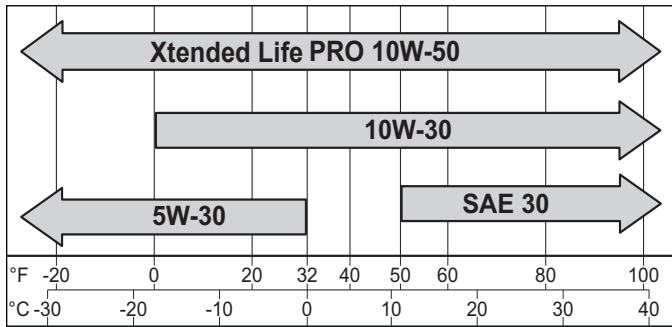

FUEL RECOMMENDATIONS

	WARNING
	Explosive Fuel can cause fires and severe burns. If a gaseous odor is detected, ventilate area and contact an authorized service technician.
LPG is extremely flammable and is heavier than air and tends to settle in low areas where a spark or flame could ignite gas. Do not start or operate this engine in a poorly ventilated area where leaking gas could accumulate and endanger safety of persons in area.	
NG is extremely flammable, is lighter than air, and rises. Do not start or operate this engine in a poorly ventilated area where leaking gas could accumulate and endanger safety of persons in area.	
To ensure personal safety, installation and repair of LPG/NG fuel supply systems must be performed only by qualified LPG/NG system technicians. Improperly installed and maintained LPG/NG equipment could cause fuel supply system or other components to malfunction, causing gas leaks.	
Observe federal, state and local laws governing LPG/NG fuel, storage, and systems.	

This engine is certified to operate on LPG or LPG/NG.

LPG Engines

LPG from an appropriate LPG fuel tank (supplied separately) is required to operate this engine.

NG Engines

NG from an approved system or source of supply can be used to operate this engine.

STORAGE

If engine will be out of service for 2 months or more follow procedure below.

1. Change oil while engine is still warm from operation (NOT required if using Xtended Life PRO 10W-50 full-synthetic oil). Remove spark plug(s) and pour about 1 oz. of engine oil into cylinder(s). Replace spark plug(s) and crank engine slowly to distribute oil.
2. Disconnect negative (-) battery cable.
3. Separate LPG tank from unit and store separately in an area designated for safe LPG tank storage.
4. Store engine in a clean, dry place.

Specifications

ENGINE IDENTIFICATION NUMBERS

Rehiko engine identification numbers (model, specification, and serial) should be referenced for efficient repair, ordering correct parts, and engine replacement.

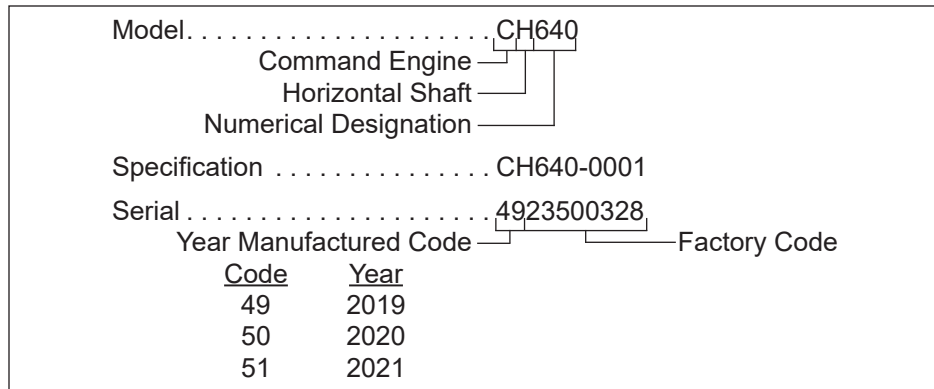

GENERAL SPECIFICATIONS ^{4,7}	CH18/CH20/ CH640	CH23	CH25/ CH730/CH740
Bore	77 mm (3.03 in.)	80 mm (3.15 in.)	83 mm (3.27 in.)
Stroke	67 mm (2.64 in.)		
Displacement	624 cc (38 cu. in.)	674 cc (41 cu. in.)	725 cc (44 cu. in.)
Oil Capacity (refill)	1.6-1.8 L (1.7-1.9 U.S. qt.)		
Maximum Angle of Operation (@ full oil level) ⁵	25°		

TORQUE SPECIFICATIONS ^{4,6}	CH18/CH20/ CH640	CH23	CH25/ CH730/CH740
Blower Housing and Sheet Metal			
M5 Fasteners	6.2 N·m (55 in. lb.) into new holes 4.0 N·m (35 in. lb.) into used holes		
M6 Fasteners	10.7 N·m (95 in. lb.) into new holes 7.3 N·m (65 in. lb.) into used holes		
Carburetor and Intake Manifold			
Intake Manifold Mounting Fastener (torque in 2 increments)	first to 7.4 N·m (66 in. lb.) finally to 9.9 N·m (88 in. lb.)		
M6 Mounting Screw or Nut	6.2-7.3 N·m (55-65 in. lb.)		
Closure Plate			
Fastener	24.4 N·m (216 in. lb.)		
Connecting Rod			
Cap Fastener (torque in increments)	22.7 N·m (200 in. lb.)		
8 mm straight shank	14.7 N·m (130 in. lb.)		
8 mm step-down	11.3 N·m (100 in. lb.)		
6 mm straight shank			

⁴ Values are in Metric units. Values in parentheses are English equivalents.

⁵ Exceeding maximum angle of operation may cause engine damage from insufficient lubrication.

⁶ Lubricate threads with engine oil prior to assembly.

⁷ Any and all horsepower (hp) references by Rehiko Certified Power Ratings and per SAE J1940 & J1995 hp standards. Details on Certified Power Ratings can be found at engines.rehiko.com.

Specifications

TORQUE SPECIFICATIONS ^{4,6}	CH18/CH20/ CH640	CH23	CH25/ CH730/CH740
Crankcase			
Breather Cover Fastener	11.3 N·m (100 in. lb.) into new holes 7.3 N·m (65 in. lb.) into used holes		
Oil Drain Plug	13.6 N·m (10 ft. lb.)		
Cylinder Head			
Fastener (torque in 2 increments) Nut	first to 16.9 N·m (150 in. lb.) finally to 35.5 N·m (315 in. lb.)		
Bolt (torque in 2 increments)	first to 22.6 N·m (200 in. lb.) finally to 41.8 N·m (370 in. lb.)		
Rocker Arm Screw Black Screw (M6x1.0x34) Silver Screw (M6x1.0x45)	18.1 N·m (160 in. lb.) 13.6 N·m (120 in. lb.)		
Flywheel			
Fan Fastener	9.9 N·m (88 in. lb.)		
Flywheel Retaining Screw	66.4 N·m (49 ft. lb.)		
Governor			
Lever Nut	6.8 N·m (60 in. lb.)		
Ignition			
Spark Plug	27 N·m (20 ft. lb.)		
Module Fastener	4.0-6.2 N·m (35-55 in. lb.)		
Rectifier-Regulator Fastener	1.4 N·m (12.6 in. lb.)		
Muffler			
Retaining Nut	24.4 N·m (216 in. lb.)		
Oil Cooler			
Adapter Nipple	27 N·m (20 ft. lb.)		
Oil Sentry™			
Pressure Switch	4.5 N·m (40 in. lb.)		
Regulator			
Bracket Screws	22.6 N·m (200 in. lb.)		
Screws	24.4 N·m (216 in. lb.)		
Solenoid (Starter)			
Mounting Hardware Nippondenso Starter Delco-Remy Starter	6.0-9.0 N·m (53-79 in. lb.) 4.0-6.0 N·m (35-53 in. lb.)		
Nut, Positive (+) Brush Lead Nippondenso Starter Delco-Remy Starter	8.0-12.0 N·m (71-106 in. lb.) 8.0-11.0 N·m (71-97 in. lb.)		
Speed Control Bracket			
Fastener	10.7 N·m (95 in. lb.) into new holes 7.3 N·m (65 in. lb.) into used holes		

⁴ Values are in Metric units. Values in parentheses are English equivalents.

⁶ Lubricate threads with engine oil prior to assembly.

Specifications

TORQUE SPECIFICATIONS ^{4,6}	CH18/CH20/ CH640	CH23	CH25/ CH730/CH740
Starter Assembly			
Thru Bolt Inertia Drive Nippondenso Solenoid Shift Delco-Remy Solenoid Shift	4.5-5.7 N·m (40-50 in. lb.) 4.5-7.5 N·m (40-84 in. lb.) 5.6-9.0 N·m (49-79 in. lb.)		
Mounting Screw	15.3 N·m (135 in. lb.)		
Brush Holder Mounting Screw	2.5-3.3 N·m (22-29 in. lb.)		
Stator			
Mounting Screw	6.2 N·m (55 in. lb.)		
Valve Cover			
Gasket Style Cover Fastener	3.4 N·m (30 in. lb.)		
Black O-ring Style Cover Fastener w/Shoulder Screws w/Flange Screws and Spacers	5.6 N·m (50 in. lb.) 9.9 N·m (88 in. lb.)		
Yellow or Brown O-ring Style Cover Fastener w/Integral Metal Spacers	9.0 N·m (80 in. lb.)		
Vaporizer			
3/8 in. Screw	29.4 N·m (260 in. lb.)		
1/4 in. Screw	7.9 N·m (70 in. lb.)		

CLEARANCE SPECIFICATIONS ⁴	CH18/CH20/ CH640	CH23	CH25/ CH730/CH740
Camshaft			
End Play (w/shim)	0.076/0.127 mm (0.0030/0.0050 in.)		
Running Clearance	0.025/0.063 mm (0.0010/0.0025 in.)		
Bore I.D. New Max. Wear Limit	20.000/20.025 mm (0.7874/0.7884 in.) 20.038 mm (0.7889 in.)		
Bearing Surface O.D. New Max. Wear Limit	19.962/19.975 mm (0.7859/0.7864 in.) 19.959 mm (0.7858 in.)		
Connecting Rod			
Connecting Rod-to-Crankpin Running Clearance New Max. Wear Limit	0.030/0.055 mm (0.0012/0.0022 in.) 0.070 mm (0.0028 in.)		
Connecting Rod-to-Crankpin Side Clearance	0.26/0.63 mm (0.0102/0.0248 in.)		
Connecting Rod-to-Piston Pin Running Clearance	0.015/0.028 mm (0.0006/0.0011 in.)		
Piston Pin End I.D. New Max. Wear Limit	17.015/17.023 mm (0.6699/0.6702 in.) 17.036 mm (0.6707 in.)		

⁴ Values are in Metric units. Values in parentheses are English equivalents.

⁶ Lubricate threads with engine oil prior to assembly.

Specifications

CLEARANCE SPECIFICATIONS ⁴	CH18/CH20/ CH640	CH23	CH25/ CH730/CH740
Crankcase			
Governor Cross Shaft Bore I.D. 6 mm Shaft New Max. Wear Limit	6.025/6.050 mm (0.2372/0.2382 in.) 6.063 mm (0.2387 in.)		
8 mm Shaft New Max. Wear Limit	8.025/8.075 mm (0.3159/0.3179 in.) 8.088 mm (0.3184 in.)		
Crankshaft			
End Play (free)	0.070/0.590 mm (0.0028/0.0230 in.)		
End Play (w/thrust bearing components)	0.070/1.190 mm (0.0028/0.0468 in.)		
Except CH25 Engines Below Serial No. 2403500008	0.050/0.750 mm (0.0020/0.0295 in.)		
Bore (in crankcase) New Max. Wear Limit	40.965/41.003 mm (1.6128/1.6143 in.) 41.016 mm (1.6148 in.)		
Crankshaft to Sleeve Bearing (crankcase) Running Clearance-New	0.03/0.09 mm (0.0012/0.0035 in.)		
Bore (in closure plate) New	40.987/40.974 mm (1.6136/1.6131 in.)		
Crankshaft Bore (in closure plate)-to-Crankshaft Running Clearance-New	0.039/0.074 mm (0.0015/0.0029 in.)		
Flywheel End Main Bearing Journal O.D. - New O.D. - Max. Wear Limit Max. Taper Max. Out-of-Round	40.913/40.935 mm (1.6107/1.6116 in.) 40.84 mm (1.608 in.) 0.022 mm (0.0009 in.) 0.025 mm (0.0010 in.)		
Closure Plate End Main Bearing Journal O.D. - New O.D. - Max. Wear Limit Max. Taper Max. Out-of-Round	40.913/40.935 mm (1.6107/1.6116 in.) 40.84 mm (1.608 in.) 0.022 mm (0.0009 in.) 0.025 mm (0.0010 in.)		
Connecting Rod Journal O.D. - New O.D. - Max. Wear Limit Max. Taper Max. Out-of-Round	35.955/35.973 mm (1.4156/1.4163 in.) 35.94 mm (1.415 in.) 0.018 mm (0.0007 in.) 0.025 mm (0.0010 in.)		
T.I.R. PTO End, Crank in Engine Entire Crank, in V-Blocks	0.279 mm (0.0110 in.) 0.10 mm (0.0039 in.)		
Cylinder Bore			
Bore I.D. New	77.000/77.025 mm (3.0315/3.0325 in.)	80.000/80.025 mm (3.1496/3.1506 in.)	82.988/83.013 mm (3.2672/3.2682 in.)
Max. Wear Limit	77.063 mm (3.0340 in.)	80.065 mm (3.1522 in.)	83.051 mm (3.2697 in.)
Max. Out-of-Round	0.12 mm (0.0047 in.)		
Max. Taper	0.05 mm (0.0020 in.)		

⁴ Values are in Metric units. Values in parentheses are English equivalents.

Specifications

CLEARANCE SPECIFICATIONS ⁴	CH18/CH20/ CH640	CH23	CH25/ CH730/CH740
Cylinder Head			
Max. Out-of-Flatness	0.076 mm (0.003 in.)		0.1 mm (0.004 in.)
Governor			
Governor Cross Shaft-to-Crankcase Running Clearance 6 mm Shaft 8 mm Shaft	0.013/0.075 mm (0.0005/0.0030 in.) 0.025/0.126 mm (0.0009/0.0049 in.)		
Cross Shaft O.D. 6 mm Shaft New Max. Wear Limit 8 mm Shaft New Max. Wear Limit	5.975/6.012 mm (0.2352/0.2367 in.) 5.962 mm (0.2347 in.) 7.949/8.000 mm (0.3129/0.3149 in.) 7.936 mm (0.3124 in.)		
Governor Gear Shaft-to-Governor Gear Running Clearance	0.015/0.140 mm (0.0006/0.0055 in.)		
Gear Shaft O.D. New Max. Wear Limit	5.990/6.000 mm (0.2358/0.2362 in.) 5.977 mm (0.2353 in.)		
Ignition			
Spark Plug Gap	0.76 mm (0.030 in.) for All Except NG with CD Fixed 0.51 mm (0.020 in.) for NG with CD Fixed		
Module Air Gap	0.28/0.33 mm (0.011/0.013 in.)		
Piston, Piston Rings, and Piston Pin			
Piston-to-Piston Pin Running Clearance	0.006/0.017 mm (0.0002/0.0007 in.)		
Pin Bore I.D. New Max. Wear Limit	17.006/17.012 mm (0.6695/0.6698 in.) 17.025 mm (0.6703 in.)		
Pin O.D. New Max. Wear Limit	16.995/17.000 mm (0.6691/0.6693 in.) 16.994 mm (0.6691 in.)		
Top Compression Ring-to-Groove Side Clearance	0.040/0.080 mm (0.0016/0.0031 in.)	0.030/0.076 mm (0.0012/0.0030 in.)	0.025/0.048 mm (0.0010/0.0019 in.)
Middle Compression Ring-to-Groove Side Clearance	0.040/0.080 mm (0.0016/0.0031 in.)	0.030/0.076 mm (0.0012/0.0030 in.)	0.015/0.037 mm (0.0006/0.0015 in.)
Oil Control Ring-to-Groove Side Clearance	0.060/0.202 mm (0.0024/0.0080 in.)	0.046/0.196 mm (0.0018/0.0077 in.)	0.026/0.176 mm (0.0010/0.0070 in.)
Top and Middle Compression Ring End Gap New Bore	0.25/0.45 mm (0.0098/0.0177 in.)	0.18/0.46 mm (0.0071/0.0181 in.)	0.25/0.56 mm (0.0100/0.0224 in.)
Used Bore (Max)	0.77 mm (0.030 in.)	0.80 mm (0.0315 in.)	0.94 mm (0.037 in.)
Thrust Face O.D. ⁸ New	76.943/76.961 mm (3.0292/3.0299 in.)	79.943/79.961 mm (3.1473/3.1480 in.)	82.949/82.967 mm (3.2656/3.2664 in.)
Max. Wear Limit	76.816 mm (3.0242 in.)	79.816 mm (3.1423 in.)	82.822 mm (3.2606 in.)
Piston Thrust Face-to-Cylinder Bore ⁸ Running Clearance New	0.039/0.082 mm (0.0015/0.0032 in.)		

⁴ Values are in Metric units. Values in parentheses are English equivalents.



⁸ Measure 6 mm (0.24 in.) above bottom of piston skirt at right angles to piston pin.

CLEARANCE SPECIFICATIONS ⁴	CH18/CH20/ CH640	CH23	CH25/ CH730/CH740
Valves and Valve Lifters			
Hydraulic Valve Lifter to Crankcase Running Clearance	0.0241/0.0501 mm (0.0009/0.0020 in.)		
Intake Valve Stem-to-Valve Guide Running Clearance	0.038/0.076 mm (0.0015/0.0030 in.)		
Exhaust Valve Stem-to-Valve Guide Running Clearance	0.050/0.088 mm (0.0020/0.0035 in.)		
Intake Valve Guide I.D. New Max. Wear Limit	7.038/7.058 mm (0.2771/0.2779 in.) 7.134 mm (0.2809 in.)		
Exhaust Valve Guide I.D. New Max. Wear Limit	7.038/7.058 mm (0.2771/0.2779 in.) 7.159 mm (0.2819 in.)		
Valve Guide Reamer Size Standard 0.25 mm O.S.	7.048 mm (0.2775 in.) 7.298 mm (0.2873 in.)		
Intake Valve Minimum Lift	8.07 mm (0.3177 in.)		
Exhaust Valve Minimum Lift	8.07 mm (0.3177 in.)		
Nominal Valve Seat Angle	45°		





⁴ Values are in Metric units. Values in parentheses are English equivalents.

Specifications

GENERAL TORQUE VALUES

English Fastener Torque Recommendations for Standard Applications				
Bolts, Screws, Nuts and Fasteners Assembled Into Cast Iron or Steel				Grade 2 or 5 Fasteners Into Aluminum
Size	 Grade 2	 Grade 5	 Grade 8	
Tightening Torque: N·m (in. lb.) ± 20%				
8-32	2.3 (20)	2.8 (25)	—	2.3 (20)
10-24	3.6 (32)	4.5 (40)	—	3.6 (32)
10-32	3.6 (32)	4.5 (40)	—	—
1/4-20	7.9 (70)	13.0 (115)	18.7 (165)	7.9 (70)
1/4-28	9.6 (85)	15.8 (140)	22.6 (200)	—
5/16-18	17.0 (150)	28.3 (250)	39.6 (350)	17.0 (150)
5/16-24	18.7 (165)	30.5 (270)	—	—
3/8-16	29.4 (260)	—	—	—
3/8-24	33.9 (300)	—	—	—

Tightening Torque: N·m (ft. lb.) ± 20%				
5/16-24	—	—	40.7 (30)	—
3/8-16	—	47.5 (35)	67.8 (50)	—
3/8-24	—	54.2 (40)	81.4 (60)	—
7/16-14	47.5 (35)	74.6 (55)	108.5 (80)	—
7/16-20	61.0 (45)	101.7 (75)	142.5 (105)	—
1/2-13	67.8 (50)	108.5 (80)	155.9 (115)	—
1/2-20	94.9 (70)	142.4 (105)	223.7 (165)	—
9/16-12	101.7 (75)	169.5 (125)	237.3 (175)	—
9/16-18	135.6 (100)	223.7 (165)	311.9 (230)	—
5/8-11	149.5 (110)	244.1 (180)	352.6 (260)	—
5/8-18	189.8 (140)	311.9 (230)	447.5 (330)	—
3/4-10	199.3 (147)	332.2 (245)	474.6 (350)	—
3/4-16	271.2 (200)	440.7 (325)	637.3 (470)	—

Metric Fastener Torque Recommendations for Standard Applications						
Size	Property Class					Noncritical Fasteners Into Aluminum
	 4.8	 5.8	 8.8	 10.9	 12.9	
Tightening Torque: N·m (in. lb.) ± 10%						
M4	1.2 (11)	1.7 (15)	2.9 (26)	4.1 (36)	5.0 (44)	2.0 (18)
M5	2.5 (22)	3.2 (28)	5.8 (51)	8.1 (72)	9.7 (86)	4.0 (35)
M6	4.3 (38)	5.7 (50)	9.9 (88)	14.0 (124)	16.5 (146)	6.8 (60)
M8	10.5 (93)	13.6 (120)	24.4 (216)	33.9 (300)	40.7 (360)	17.0 (150)
Tightening Torque: N·m (ft. lb.) ± 10%						
M10	21.7 (16)	27.1 (20)	47.5 (35)	66.4 (49)	81.4 (60)	33.9 (25)
M12	36.6 (27)	47.5 (35)	82.7 (61)	116.6 (86)	139.7 (103)	61.0 (45)
M14	58.3 (43)	76.4 (56)	131.5 (97)	184.4 (136)	219.7 (162)	94.9 (70)

Torque Conversions	
N·m = in. lb. x 0.113	in. lb. = N·m x 8.85
N·m = ft. lb. x 1.356	ft. lb. = N·m x 0.737

Certain quality tools are designed to help you perform specific disassembly, repair, and reassembly procedures. By using these tools, you can properly service engines easier, faster, and safer! In addition, you'll increase your service capabilities and customer satisfaction by decreasing engine downtime.

Here is a list of tools and their source.

NOTE: Not all tools listed are required to service this engine.

SEPARATE TOOL SUPPLIERS

Rehiko Tools
Contact your local Rehiko source of supply.

SE Tools
415 Howard St.
Lapeer, MI 48446
Phone 810-664-2981
Toll Free 800-664-2981
Fax 810-664-8181

Design Technology Inc.
768 Burr Oak Drive
Westmont, IL 60559
Phone 630-920-1300
Fax 630-920-0011

TOOLS

Description	Source/Part No.
Alcohol Content Tester For testing alcohol content (%) in reformulated/oxygenated fuels.	Rehiko 25 455 11-S
Camshaft Endplay Plate For checking camshaft endplay.	SE Tools KLR-82405
Camshaft Seal Protector (Aegis) For protecting seal during camshaft installation.	SE Tools KLR-82417
Cylinder Leakdown Tester For checking combustion retention and if cylinder, piston, rings, or valves are worn. Individual component available: Adapter 12 mm x 14 mm (Required for leakdown test on XT-6 engines)	Rehiko 25 761 05-S Design Technology Inc. DTI-731-03
Dealer Tool Kit (Domestic) Complete kit of Rehiko required tools. Components of 25 761 39-S Ignition System Tester Cylinder Leakdown Tester Oil Pressure Test Kit Rectifier-Regulator Tester (120 V AC/60Hz)	Rehiko 25 761 39-S Rehiko 25 455 01-S Rehiko 25 761 05-S Rehiko 25 761 06-S Rehiko 25 761 20-S
Dealer Tool Kit (International) Complete kit of Rehiko required tools. Components of 25 761 42-S Ignition System Tester Cylinder Leakdown Tester Oil Pressure Test Kit Rectifier-Regulator Tester (240 V AC/50Hz)	Rehiko 25 761 42-S Rehiko 25 455 01-S Rehiko 25 761 05-S Rehiko 25 761 06-S Rehiko 25 761 41-S
Digital Vacuum/Pressure Tester For checking crankcase vacuum. Individual component available: Rubber Adapter Plug	Design Technology Inc. DTI-721-01 Design Technology Inc. DTI-721-10
Electronic Fuel Injection (EFI) Diagnostic Software For Laptop or Desktop PC.	Rehiko 25 761 23-S
EFI Service Kit For troubleshooting and setting up an EFI engine. Components of 24 761 01-S Fuel Pressure Tester Noid Light 90° Adapter Code Plug, Red Wire Code Plug, Blue Wire Shrader Valve Adapter Hose Wire Probe Set (2 pieces regular wire with clip; 1 piece fused wire) Hose Removal Tool, Dual Size/End (also sold as individual Rehiko tool) K-Line Adapter Jumper Lead Wiring Harness	Rehiko 24 761 01-S Design Technology Inc. DTI-019 DTI-021 DTI-023 DTI-027 DTI-029 DTI-037 DTI-031 DTI-033 Rehiko 25 176 23-S
Rehiko Wireless Diagnostic System Module (Bluetooth®) For wireless Android EFI diagnostics. Individual component available: Wireless Diagnostic System Interface Cable	Rehiko 25 761 45-S Rehiko 25 761 44-S

Tools and Aids

TOOLS

Description	Source/Part No.
Flywheel Puller For properly removing flywheel from engine.	SE Tools KLR-82408
Flywheel Anchor Bolts, Washers, Nuts Tool Used with Flywheel Puller for properly removing flywheel from 5400 Series engine.	Rehiko 25 086 753-S
Hose Removal Tool, Dual Size/End (also available in EFI Service Kit) Used to properly remove fuel hose from engine components.	Rehiko 25 455 20-S
Hydraulic Valve Lifter Tool For removing and installing hydraulic lifters.	Rehiko 25 761 38-S
Ignition System Tester For testing output on all systems, including CD.	Rehiko 25 455 01-S
Inductive Tachometer (Digital) For checking operating speed (RPM) of an engine.	Design Technology Inc. DTI-110
Offset Wrench (K and M Series) For removing and reinstalling cylinder barrel retaining nuts.	Rehiko 52 455 04-S
Oil Pressure Test Kit For testing/verifying oil pressure on pressure lubricated engines.	Rehiko 25 761 06-S
Rectifier-Regulator Tester (120 volt current) Rectifier-Regulator Tester (240 volt current) For testing rectifier-regulators. Components of 25 761 20-S and 25 761 41-S CS-PRO Regulator Test Harness Special Regulator Test Harness with Diode	Rehiko 25 761 20-S Rehiko 25 761 41-S Design Technology Inc. DTI-031R DTI-033R
Spark Advance Module (SAM) Tester For testing SAM (ASAM and DSAM) on engines with SMART-SPARK™.	Rehiko 25 761 40-S
Starter Servicing Kit (All Starters) For removing and reinstalling drive retaining rings and brushes. Individual component available: Starter Brush Holding Tool (Solenoid Shift)	SE Tools KLR-82411 SE Tools KLR-82416
Stepper Motor Controller Tool For testing operation of stepper motor/Digital Linear Actuator (DLA).	Rehiko 25 455 21-S
Jumper Lead Tool For use with Stepper Motor Controller Tool to test rotary stepper motor.	Rehiko 25 518 43-S
Triad/OHC Timing Tool Set For holding cam gears and crankshaft in timed position while installing timing belt.	Rehiko 28 761 01-S
Valve Guide Reamer (K and M Series) For properly sizing valve guides after installation.	Design Technology Inc. DTI-K828
Valve Guide Reamer O.S. (Command Series) For reaming worn valve guides to accept replacement oversize valves. Can be used in low-speed drill press or with handle below for hand reaming.	Rehiko 25 455 12-S
Reamer Handle For hand reaming using Rehiko 25 455 12-S reamer.	Design Technology Inc. DTI-K830

AIDS

Description	Source/Part No.
Camshaft Lubricant (Valspar ZZ613)	Rehiko 25 357 14-S
Dielectric Grease (GE/Novaguard G661)	Rehiko 25 357 11-S
Dielectric Grease	Loctite® 51360
Rehiko Electric Starter Drive Lubricant (Inertia Drive)	Rehiko 52 357 01-S
Rehiko Electric Starter Drive Lubricant (Solenoid Shift)	Rehiko 52 357 02-S
RTV Silicone Sealant Loctite® 5900® Heavy Body in 4 oz. aerosol dispenser. Only oxime-based, oil resistant RTV sealants, such as those listed, are approved for use. Permatex® the Right Stuff® 1 Minute Gasket™ or Loctite® Nos. 5900® or 5910® are recommended for best sealing characteristics.	Rehiko 25 597 07-S Loctite® 5910® Loctite® Ultra Black 598™ Loctite® Ultra Blue 587™ Loctite® Ultra Copper 5920™ Permatex® the Right Stuff® 1 Minute Gasket™
Spline Drive Lubricant	Rehiko 25 357 12-S

FLYWHEEL HOLDING TOOL

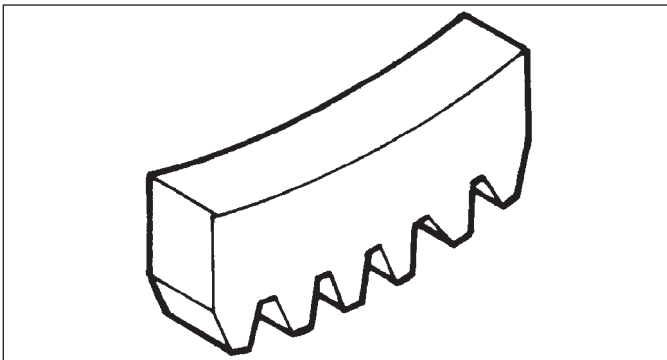

A flywheel holding tool can be made out of an old junk flywheel ring gear and used in place of a strap wrench.

1. Using an abrasive cut-off wheel, cut out a six tooth segment of ring gear as shown.
2. Grind off any burrs or sharp edges.
3. Invert segment and place it between ignition bosses on crankcase so tool teeth engage flywheel ring gear teeth. Bosses will lock tool and flywheel in position for loosening, tightening, or removing with a puller.

ROCKER ARM/CRANKSHAFT TOOL

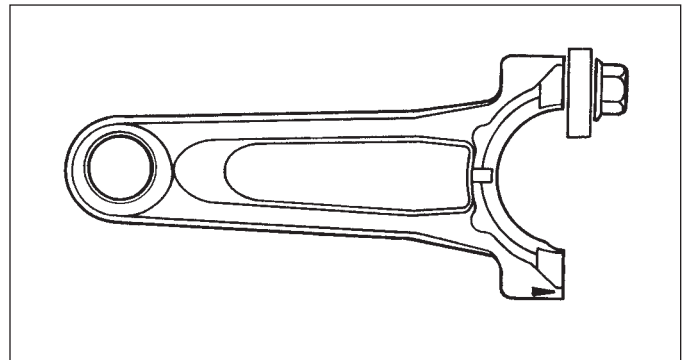

A spanner wrench to lift rocker arms or turn crankshaft may be made out of an old junk connecting rod.

1. Find a used connecting rod from a 10 HP or larger engine. Remove and discard rod cap.
2. Remove studs of a Posi-Lock rod or grind off aligning steps of a Command rod, so joint surface is flat.
3. Find a 1 in. long capscrew with correct thread size to match threads in connecting rod.
4. Use a flat washer with correct I.D. to slip on capscrew and approximately 1 in. O.D. Assemble capscrew and washer to joint surface of rod.

Troubleshooting

TROUBLESHOOTING GUIDE

When troubles occur, be sure to check simple causes which, at first, may seem too obvious to be considered. For example, a starting problem could be caused by an empty fuel tank.

Some general common causes of engine troubles are listed below and vary by engine specification. Use these to locate causing factors.

Engine Cranks But Will Not Start

- Battery connected backwards.
- Blown fuse.
- Carburetor solenoid malfunction.
- Choke not closing.
- Clogged fuel line or fuel filter.
- Diode in wiring harness failed in open circuit mode.
- DSAI or DSAM malfunction.
- Empty fuel tank.
- Faulty electronic control unit.
- Faulty ignition coil(s).
- Faulty spark plug(s).
- Fuel pump malfunction-vacuum hose clogged or leaking.
- Fuel shut-off valve closed.
- Ignition module(s) faulty or improperly gapped.
- Insufficient voltage to electronic control unit.
- Interlock switch is engaged or faulty.
- Key switch or kill switch in OFF position.
- Low oil level.
- Quality of fuel (dirt, water, stale, mixture).
- SMART-SPARK™ malfunction.
- Spark plug lead(s) disconnected.

Engine Starts But Does Not Keep Running

- Faulty carburetor.
- Faulty cylinder head gasket.
- Faulty or misadjusted choke or throttle controls.
- Fuel pump malfunction-vacuum hose clogged or leaking.
- Intake system leak.
- Loose wires or connections that intermittently ground ignition kill circuit.
- Quality of fuel (dirt, water, stale, mixture).
- Restricted fuel tank cap vent.

Engine Starts Hard

- Clogged fuel line or fuel filter.
- Engine overheated.
- Faulty ACR mechanism.
- Faulty or misadjusted choke or throttle controls.
- Faulty spark plug(s).
- Flywheel key sheared.
- Fuel pump malfunction-vacuum hose clogged or leaking.
- Interlock switch is engaged or faulty.
- Loose wires or connections that intermittently ground ignition kill circuit.
- Low compression.
- Quality of fuel (dirt, water, stale, mixture).
- Weak spark.

Engine Will Not Crank

- Battery is discharged.
- Faulty electric starter or solenoid.
- Faulty key switch or ignition switch.
- Interlock switch is engaged or faulty.
- Loose wires or connections that intermittently ground ignition kill circuit.
- Pawls not engaging in drive cup.
- Seized internal engine components.

Engine Runs But Misses

- Carburetor adjusted incorrectly.
- Engine overheated.
- Faulty spark plug(s).
- Ignition module(s) faulty or improperly gapped.
- Incorrect crankshaft position sensor air gap.
- Interlock switch is engaged or faulty.
- Loose wires or connections that intermittently ground ignition kill circuit.
- Quality of fuel (dirt, water, stale, mixture).
- Spark plug lead(s) disconnected.
- Spark plug lead boot loose on plug.
- Spark plug lead loose.

Engine Will Not Idle

- Engine overheated.
- Faulty spark plug(s).
- Idle fuel adjusting needle(s) improperly set.
- Idle speed adjusting screw improperly set.
- Inadequate fuel supply.
- Low compression.
- Quality of fuel (dirt, water, stale, mixture).
- Restricted fuel tank cap vent.

Engine Overheats

- Cooling fan broken.
- Excessive engine load.
- Fan belt failed/off.
- Faulty carburetor.
- High crankcase oil level.
- Lean fuel mixture.
- Low cooling system fluid level.
- Low crankcase oil level.
- Radiator, and/or cooling system components clogged, restricted, or leaking.
- Water pump belt failed/broken.
- Water pump malfunction.

Engine Knocks

- Excessive engine load.
- Hydraulic lifter malfunction.
- Incorrect oil viscosity/type.
- Internal wear or damage.
- Low crankcase oil level.
- Quality of fuel (dirt, water, stale, mixture).

Engine Loses Power

- Dirty air cleaner element.
- Engine overheated.
- Excessive engine load.
- Restricted exhaust.
- Faulty spark plug(s).
- High crankcase oil level.
- Incorrect governor setting.
- Low battery.
- Low compression.
- Low crankcase oil level.
- Quality of fuel (dirt, water, stale, mixture).

Engine Uses Excessive Amount of Oil

- Loose or improperly torqued fasteners.
- Blown head gasket/overheated.
- Breather reed broken.
- Clogged, broken, or inoperative crankcase breather.
- Crankcase overfilled.
- Incorrect oil viscosity/type.
- Worn cylinder bore.
- Worn or broken piston rings.
- Worn valve stems/valve guides.

Oil Leaks from Oil Seals, Gaskets

- Breather reed broken.
- Clogged, broken, or inoperative crankcase breather.
- Loose or improperly torqued fasteners.
- Piston blow by, or leaky valves.
- Restricted exhaust.

EXTERNAL ENGINE INSPECTION



NOTE: It is good practice to drain oil at a location away from workbench. Be sure to allow ample time for complete drainage.

Before cleaning or disassembling engine, make a thorough inspection of its external appearance and condition. This inspection can give clues to what might be found inside engines (and cause) when it is disassembled.

- Check for buildup of dirt and debris on crankcase, cooling fins, grass screen, and other external surfaces. Dirt or debris on these areas can cause overheating.
- Check for obvious fuel and oil leaks, and damaged components. Excessive oil leakage can indicate a clogged or inoperative breather, worn or damaged seals or gaskets, or loose fasteners.
- Check air cleaner cover and base for damage or indications of improper fit and seal.
- Check air cleaner element. Look for holes, tears, cracked or damaged sealing surfaces, or other damage that could allow unfiltered air into engine. A dirty or clogged element could indicate insufficient or improper maintenance.
- Check carburetor throat for dirt. Dirt in throat is further indication that air cleaner was not functioning properly.
- Check if oil level is within operating range on dipstick. If it is above, sniff for gasoline odor.
- Check condition of oil. Drain oil into a container; it should flow freely. Check for metal chips and other foreign particles.

Sludge is a natural by-product of combustion; a small accumulation is normal. Excessive sludge formation could indicate over rich fuel settings, weak ignition, overextended oil change interval or wrong weight or type of oil was used.

CLEANING ENGINE

	 WARNING
	<p>Cleaning Solvents can cause severe injury or death.</p> <p>Use only in well ventilated areas away from ignition sources.</p>
<p>Carburetor cleaners and solvents are extremely flammable. Follow cleaner manufacturer's warnings and instructions on its proper and safe use. Never use gasoline as a cleaning agent.</p>	

After inspecting external condition of engine, clean engine thoroughly before disassembly. Clean individual components as engine is disassembled. Only clean parts can be accurately inspected and gauged for wear or damage. There are many commercially available cleaners that will quickly remove grease, oil, and grime from engine parts. When such a cleaner is used, follow manufacturer's instructions and safety precautions carefully.

Make sure all traces of cleaner are removed before engine is reassembled and placed into operation. Even small amounts of these cleaners can quickly break down lubricating properties of engine oil.

Troubleshooting

CRANKCASE VACUUM TEST

	⚠ WARNING
	Carbon Monoxide can cause severe nausea, fainting or death. Avoid inhaling exhaust fumes. Never run engine indoors or in enclosed spaces.
Engine exhaust gases contain poisonous carbon monoxide. Carbon monoxide is odorless, colorless, and can cause death if inhaled.	

	⚠ WARNING
	Rotating Parts can cause severe injury. Stay away while engine is in operation.
Keep hands, feet, hair, and clothing away from all moving parts to prevent injury. Never operate engine with covers, shrouds, or guards removed.	

A partial vacuum should be present in crankcase when engine is operating. Pressure in crankcase (normally caused by a clogged or improperly assembled breather) can cause oil to be forced out at oil seals, gaskets, or other available spots.

Crankcase vacuum is best measured with either a water manometer or a vacuum gauge (inches of water gauge only). Complete instructions are provided in kits.

To test crankcase vacuum with manometer:

1. Insert rubber stopper into oil fill hole. Be sure pinch clamp is installed on hose and use tapered adapters to connect hose between stopper and one manometer tube. Leave other tube open to atmosphere. Check that water level in manometer is at 0 line. Make sure pinch clamp is closed.
2. Start engine and run no-load high speed.
3. Open clamp and note water level in tube.
Level in engine side should be a minimum of 10.2 cm (4 in.) above level in open side.
If level in engine side is less than specified (low/no vacuum), or level in engine side is lower than level in open side (pressure), check for conditions in table below.
4. Close pinch clamp before stopping engine.

To test crankcase vacuum with vacuum/pressure gauge (inches of water gauge only):

1. Remove dipstick or oil fill plug/cap.
2. Install adapter into oil fill/dipstick tube opening, upside down over end of a small diameter dipstick tube, or directly into engine if a tube is not used. Insert barbed gauge fitting into hole in stopper.
3. Run engine and observe gauge reading.
Analog tester—needle movement to left of 0 is a vacuum, and movement to right indicates a pressure.
Digital tester—depress test button on top of tester.
Crankcase vacuum should be a minimum of 10.2 cm (4 in.) of water. If reading is below specification, or if pressure is present, check table below for possible causes and conclusions.

Condition	Conclusion
Crankcase breather clogged or inoperative.	NOTE: If breather is integral part of valve cover and cannot be serviced separately, replace valve cover and recheck pressure. Disassemble breather, clean parts thoroughly, check sealing surfaces for flatness, reassemble, and recheck pressure.
Seals and/or gaskets leaking. Loose or improperly torque fasteners.	Replace all worn or damaged seals and gaskets. Make sure all fasteners are tightened securely. Use appropriate torque values and sequences when necessary.
Piston blow by or leaky valves (confirm by inspecting components).	Recondition piston, rings, cylinder bore, valves and valves guides.
Restricted exhaust.	Check exhaust screen/spark arrestor (if equipped). Clean or replace as needed. Repair or replace any other damaged/restricted muffler or exhaust system parts.

COMPRESSION TEST

For Command Twins:

A compression test is best performed on a warm engine. Clean any dirt or debris away from base of spark plug(s) before removing them. Be sure choke is off, and throttle is wide open during test. Compression should be at least 160 psi and should not vary more than 15% between cylinders.

All other models:

These engines are equipped with an automatic compression release (ACR) mechanism. It is difficult to obtain an accurate compression reading because of ACR mechanism. As an alternative, use cylinder leakdown test described below.

CYLINDER LEAKDOWN TEST

A cylinder leakdown test can be a valuable alternative to a compression test. By pressurizing combustion chamber from an external air source you can determine if valves or rings are leaking, and how badly.

Cylinder leakdown tester is a relatively simple, inexpensive leakdown tester for small engines. This tester includes a quick-connect for attaching adapter hose and a holding tool.

1. Run engine for 3-5 minutes to warm it up.
2. Remove spark plug(s) and air filter from engine.
3. Rotate crankshaft until piston (of cylinder being tested) is at top dead center (TDC) of compression stroke. Hold engine in this position while testing. Holding tool supplied with tester can be used if PTO end of crankshaft is accessible. Lock holding tool onto crankshaft. Install a 3/8 in. breaker bar into hole/slot of holding tool, so it is perpendicular to both holding tool and crankshaft PTO.

If flywheel end is more accessible, use a breaker bar and socket on flywheel nut/screw to hold it in position. An assistant may be needed to hold breaker bar during testing. If engine is mounted in a piece of equipment, it may be possible to hold it by clamping or wedging a driven component. Just be certain that engine cannot rotate off of TDC in either direction.

4. Install adapter into spark plug hole, but do not attach it to tester at this time.
5. Turn regulator knob completely counterclockwise.
6. Connect an air source of at least 50 psi to tester.
7. Turn regulator knob clockwise (increase direction) until gauge needle is in yellow set area at low end of scale.
8. Connect tester quick-connect to adapter hose. While firmly holding engine at TDC, gradually open tester valve. Note gauge reading and listen for escaping air at combustion air intake, exhaust outlet, and crankcase breather.

Condition	Conclusion
Air escaping from crankcase breather.	Ring or cylinder worn.
Air escaping from exhaust system.	Defective exhaust valve/improper seating.
Air escaping from intake.	Defective intake valve/improper seating.
Gauge reading in low (green) zone.	Piston rings and cylinder in good condition.
Gauge reading in moderate (yellow) zone.	Engine is still usable, but there is some wear present. Customer should start planning for overhaul or replacement.
Gauge reading in high (red) zone.	Rings and/or cylinder have considerable wear. Engine should be reconditioned or replaced.

Air Cleaner/Intake

AIR CLEANER

These systems are CARB/EPA certified and components should not be altered or modified in any way.

Air Cleaner Components

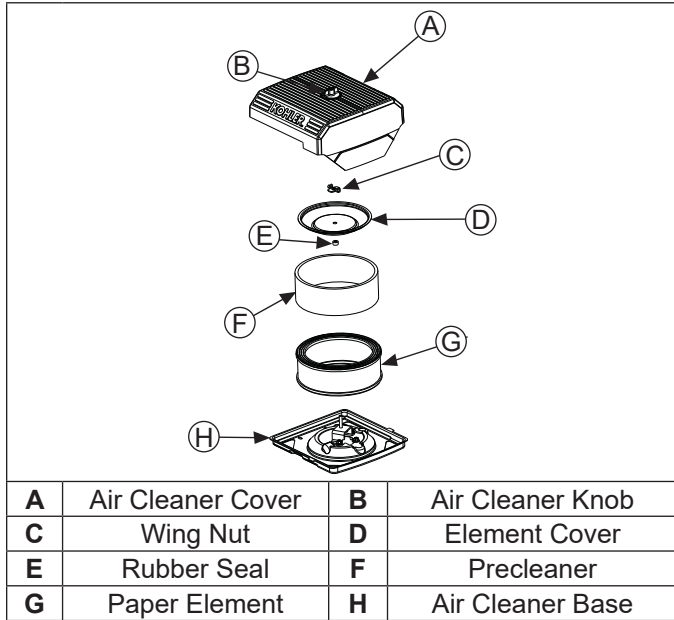

NOTE: Operating engine with loose or damaged air cleaner components could cause premature wear and failure. Replace all bent or damaged components.

NOTE: Paper element cannot be blown out with compressed air.

Loosen knob and remove air cleaner cover.

Precleaner

1. Remove precleaner from paper element.
2. Replace or wash precleaner in warm water with detergent. Rinse and allow to air dry.
3. Saturate precleaner with new engine oil; squeeze out excess oil.
4. Reinstall precleaner over paper element.

Paper Element

1. Clean area around element. Remove wing nut, element cover, and paper element with precleaner.
2. Separate precleaner from element; service precleaner and replace paper element.
3. Check condition of rubber seal and replace if necessary.
4. Install new paper element on base; install precleaner over paper element; reinstall element cover and secure with wing nut.

Reinstall air cleaner cover and secure with knob.

BREATHER TUBE

Ensure sure both ends of breather tube are properly connected.

AIR COOLING

	WARNING
	Hot Parts can cause severe burns. Do not touch engine while operating or just after stopping.
Never operate engine with heat shields or guards removed.	

Proper cooling is essential. To prevent over heating, clean screens, cooling fins, and other external surfaces of engine. Avoid spraying water at wiring harness or any electrical components. Refer to Maintenance Schedule.

Typical LPG/NG fuel systems and related components include:

- Fuel Tank (Liquid Withdrawal) (LPG only)
- Electric Lock-Off/Filter Assembly
- Vaporizer (LPG only)
- Regulator (Combination Primary/Secondary/Vacuum Lock-Off)
- Carburetor
- High Pressure Fuel Line(s) (LPG only)
- Vacuum Line

LPG/NG fuel travels through fuel line to electric lock-off/filter assembly. Lock-off opens internally when key switch is turned ON, permitting filtered fuel to flow. A vaporizer (LPG only) is mounted in flow of discharged cooling air. It absorbs heat from cooling air and transfers it to fuel, changing liquefied petroleum to a vapor or gaseous state, while partially stepping down fuel pressure. Gas/vapor flows under this decreased pressure to regulator where it is further reduced to a usable, regulated pressure. Regulator, activated by intake manifold vacuum, controls fuel flow to carburetor. In venturi of carburetor, fuel vapor is mixed with incoming air from air cleaner in correct ratio for efficient combustion.

FUEL RECOMMENDATIONS

Refer to Maintenance.

FUEL LINE

Low permeation fuel line must be installed on carbureted Rehlko Co. engines to maintain EPA and CARB regulatory compliance.

External Fuel System Components

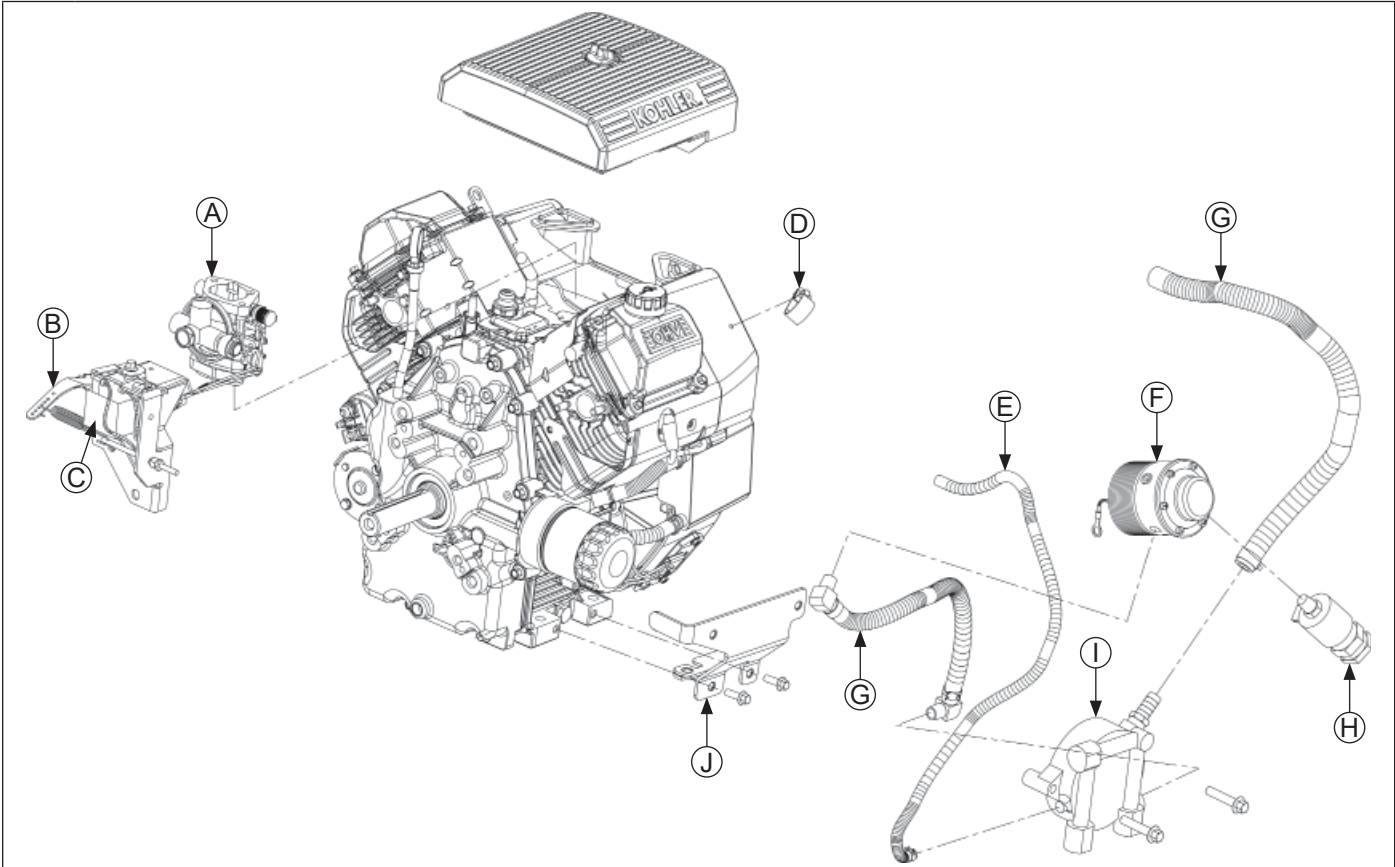

A	Carburetor	B	Governor Lever	C	Electronic Throttle Control	D	Hose Clamp
E	Vacuum Line	F	Vaporizer	G	Fuel Line	H	Electric Lock-Off/Filter
I	Regulator	J	Regulator Bracket				

Fuel System



⚠ WARNING

Explosive Fuel can cause fires and severe burns.
If a gaseous odor is detected, ventilate area and contact an authorized service technician.

LPG is extremely flammable and is heavier than air and tends to settle in low areas where a spark or flame could ignite gas. Do not start or operate this engine in a poorly ventilated area where leaking gas could accumulate and endanger safety of persons in area.

NG is extremely flammable, is lighter than air, and rises. Do not start or operate this engine in a poorly ventilated area where leaking gas could accumulate and endanger safety of persons in area.

To ensure personal safety, installation and repair of LPG/NG fuel supply systems must be performed only by qualified LPG/NG system technicians. Improperly installed and maintained LPG/NG equipment could cause fuel supply system or other components to malfunction, causing gas leaks.

Observe federal, state and local laws governing LPG/NG fuel, storage, and systems.

Nikki Carburetor Components

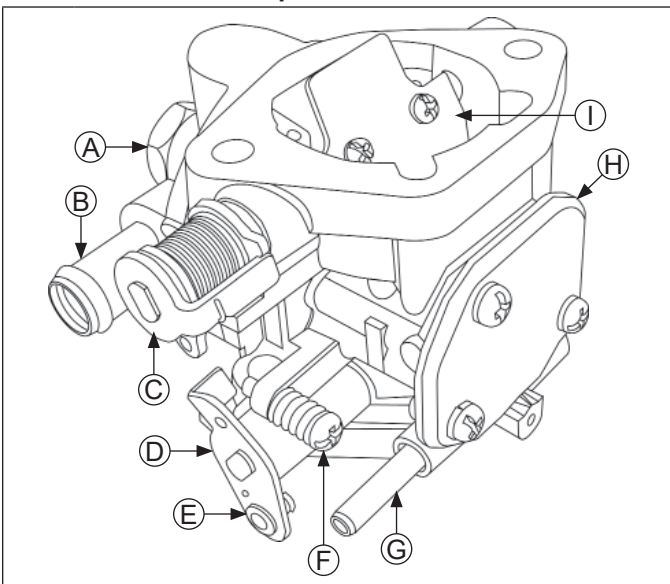

A	Rear Plug with Sealing Washer	B	Fuel Inlet
C	Choke Lever Assembly	D	Throttle Lever
E	Plastic Bushing	F	Idle Speed Adjustment Screw
G	Vacuum Port	H	Transfer Chamber Cover
I	Choke Plate/Shaft Assembly		

IMPCO Carburetor Components

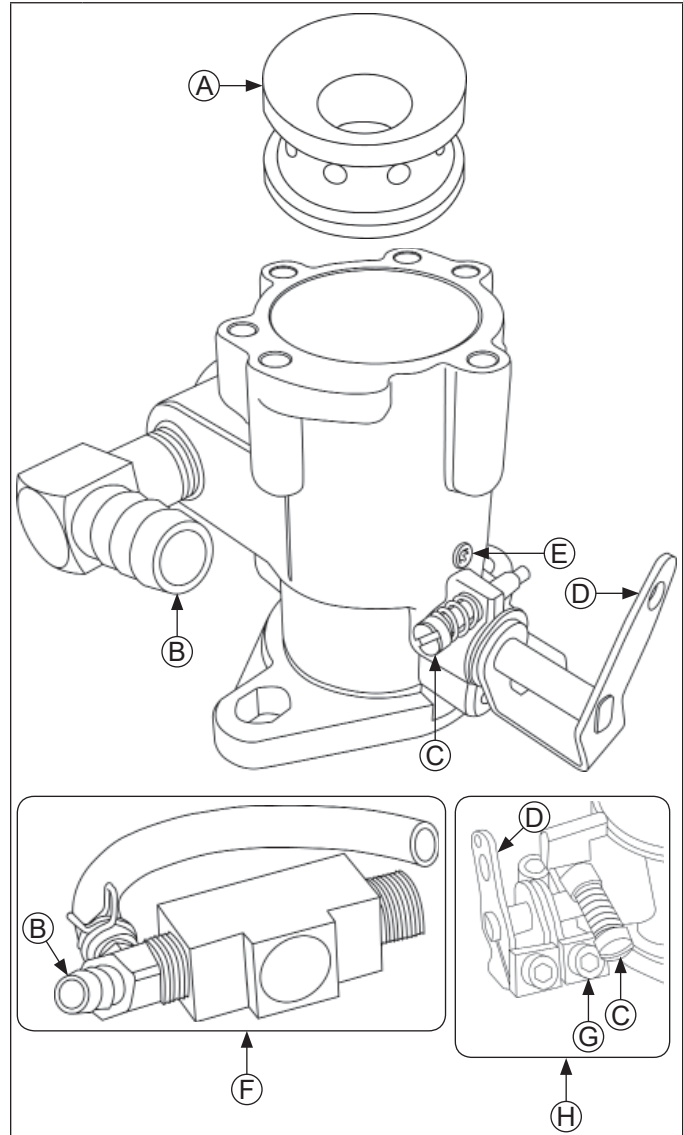

A	Venturi	B	Fuel Inlet
C	Idle Speed Adjustment Screw	D	Throttle Lever
E	Venturi Retaining Screw	F	Load Block (if equipped)
G	Idle Speed Clamp Bracket Mounting Screw	H	Clamp Brackets (if equipped)

TROUBLESHOOTING CHECKLIST

If engine starts hard, runs roughly, or stalls, check following areas.

1. Make sure LPG fuel tank is filled and shut-off valve is fully opened.
2. Make sure fuel is reaching carburetor.
3. Make sure air cleaner element and precleaner are clean and all components are fastened securely.

4. Make sure ignition, governor, exhaust, throttle, and choke control systems are all operating properly.

5. Check compression.

If engine continues to start hard, run roughly, or stall after these checks have been made, use following troubleshooting guide.

Condition	Conclusion
Engine cranks but will not start.	LPG fuel tank closed, low, or empty.
	Lock-off not opening electrically, preventing fuel flow.
	Fuel filter (located inside lock-off) dirty or blocked.
	Insufficient vacuum signal, regulator not opening. <ul style="list-style-type: none"> ● Vacuum line between carburetor and regulator cracked, leaking, kinked, or pinched. ● Carburetor loose. ● Intake manifold loose or leaking. ● Excessive internal engine wear.
	Faulty regulator. <ul style="list-style-type: none"> ● Primary valve not opening. ● Diaphragm spring adjustment incorrect. ● Idle adjustment screw incorrectly set. ● Vent(s) blocked/restricted.
	Restricted/blocked fuel line.
	Blocked carburetor fuel circuit.
	Loose/leaking fuel enrichment hose (IMPCO carburetor system).
Hard starting, runs roughly, or stalls at idle speed.	LPG fuel tank low.
	Vacuum line between carburetor and regulator pinched, cracked, or leaking.
	Carburetor idle speed set too low (should be at least 1200 RPM).
	Carburetor idle circuit restricted.
	Dirty/restricted air cleaner.
	Dirty/restricted lock-off filter.
	Frozen/malfunctioning regulator. Check/adjust primary pressure.
	Excessive external load on engine.
	Excessive internal wear.
Loose/leaking fuel enrichment hose (IMPCO carburetor system).	
Irregular or inconsistent idle.	Improper operation/adjustment of regulator, idle adjustment screw, throttle opening, and/or engine governor.
	Secondary valve in regulator not closing. Readjust idle screw (counterclockwise) so valve can close fully against seat.
	Loose/leaking vacuum line.
	Loose carburetor mounting and/or line connections.
	Damaged diaphragm(s) within regulator.
	Debris in regulator. Flush debris from drain plug or remove regulator from system, disassemble body and remove debris.
	Dirt or debris in carburetor. Remove carburetor, disassemble and clean/service as required. If venturi (IMPCO carburetor) removal is performed, mark its orientation to carburetor body for proper reinstallation.
	Loose/leaking fuel enrichment hose (IMPCO carburetor system).

Fuel System

Condition	Conclusion
Engine stalls during operation.	No fuel.
	Faulty lock-off or blocked filter.
	Improper governor setting.
	Damaged diaphragms within regulator.
	Vacuum line leaking, loose, or pinched.
	Restricted fuel line.
	Loose/leaking fuel enrichment hose (IMPCO carburetor system).
Low power.	Air cleaner or exhaust system dirty/restricted.
	Low fuel.
	Rich gas condition (flooding) through regulator. <ul style="list-style-type: none"> • Dirty/restricted valves in regulator. • Damaged primary diaphragm in regulator.
	No fuel. <ul style="list-style-type: none"> • Electric lock-off not opening, filter blocked, or restriction within fuel line. • Leaking, loose, or cracked vacuum line from carburetor to regulator. • Leaking, or loose intake system components. • Regulator primary valve not opening. • Secondary, or vacuum lock-off diaphragm within regulator leaking. • Low pressure rubber hose kinked. • Frozen regulator.
	Improper ignition timing.
	Loose/incorrect throttle lever/clamp bracket positioning.
	Loose or incorrectly positioned high speed throttle plate stop.
Engine runs lean.	Electrical problem causing intermittent lock-off operation, or lock-off is faulty.
	Filter in lock-off dirty or restricted.
	Restriction in fuel system.
	Idle holes plugged; dirt in fuel delivery channels.
	Carburetor fuel circuit restriction.
	Loose/leaking fuel enrichment hose (IMPCO carburetor system).
High fuel consumption.	Fuel leak. Check lines, connections, and system components for leaks with soapy water. Fix any leaks immediately.
	Incorrectly set regulator, or leakage from valves in regulator. Readjust, service, or replace regulator as required.
	Dirty air cleaner or precleaner.
	Choke plate in carburetor not opening completely.

LPG/NG CARBURETOR ADJUSTMENTS

NOTE: Carburetor adjustments should be made only after engine has warmed up.

NOTE: Actual low idle speed (RPM) depends on application. Refer to equipment manufacturer's recommendations. Low idle speed for basic engines is 1200 RPM.

LPG/NG carburetor and regulator are designed to deliver correct fuel-to-air mixture to engine under all operating conditions. High and low idle fuel mixture settings are preset at factory, and cannot be adjusted. These engines are equipped with an IMPCO or Nikki carburetor. Although both carburetors function similarly, each is unique and should not be interchanged.

Some IMPCO carburetors incorporate an external load block assembly, which controls final fuel flow to carburetor for all throttle positions except idle. Calibrated and flow-matched to carburetor, it functions similarly to preset fuel mixture settings in other carburetors. Load block assembly is not available separately, nor is any internal servicing permitted or possible. If a problem is encountered and determined to be caused by load block, carburetor should be replaced.

LPG/NG FUEL SYSTEM COMPONENT SERVICE

LPG/NG Carburetor - Cleaning

Carburetor may be cleaned if necessary. Removal from engine and limited disassembly will aid in cleaning.

IMPCO Carburetor

NOTE: Do not loosen or alter mounted position of clamping brackets and/or stop collar on throttle shaft. Each is preset, in correlation to a specific position of throttle plate (shaft), or acts as a stop. None of these attached components, including throttle plate or shaft, requires disassembly or removal for any carburetor servicing. All components on throttle shaft should be left intact. If settings of any one of these is inadvertently loosened or altered, each must be checked/reset, or performance and operation will be affected. Refer to procedure included in reassembly/installation sequence to check or reset.

1. Turn off fuel supply at tank.
2. Remove air cleaner, breather hose, fuel line, vacuum hose, choke, and throttle linkages. Remove mounting hardware, carburetor, and gaskets from engine. Discard gaskets.
3. Carburetor venturi may be removed for inspection and appropriate cleaning.
 - a. Remove screws securing air cleaner adapter and gasket to carburetor.
 - b. Mark a small line on outer edge of venturi for proper orientation and reinstallation later.
 - c. Loosen venturi retaining screw on side of carburetor body and lift out venturi.
4. Inspect overall condition of fuel enrichment hose attached to carburetor. It must be free of cracks, deterioration, and damage. Disconnect fuel enrichment hose from carburetor fitting to clean or check condition as required. Replace with a new Rehlko high pressure hose (LP rated) if condition is questionable in any way. Secure new hose using new clamps.
5. Clean all parts as required, use a good carburetor cleaner, following manufacturer's instructions. Blow clean, compressed air through all passages. Do not poke or probe into load block assembly as damage can be done, resulting in serious operational problems.

Nikki Carburetor

1. Turn off fuel supply.
2. Remove air cleaner, breather hose, fuel line, vacuum hose, choke, and throttle linkages. Remove nuts, carburetor, and gaskets from engine. Discard gaskets.
3. Remove fuel transfer chamber cover by removing screws. Carefully remove cover and gasket. Discard gasket.
4. Main jet is fixed and nonadjustable, but may be accessed for cleaning by removing rear plug and sealing washer. Discard washer.
5. In order to clean off-idle transfer passages and carburetor thoroughly, use a good carburetor cleaner and follow manufacturer's instructions. Blow clean, compressed air through passages and make sure all are open before reassembling. Do not use wire or metal objects to clean passages or carburetor body.

LPG/NG Carburetor - Inspection

NOTE: Do not attempt to disassemble or remove either shaft from carburetor body, including mounted clamp brackets on IMPCO style carburetors. Screws attaching choke and throttle plate to their respective shafts are staked or bonded to prevent loosening. Plate(s) and shaft(s) are not available separately. If detrimental wear or damage is found in any parts, carburetor should be replaced.

1. Inspect carburetor body and removable venturi (IMPCO carburetor) for cracks, holes, and other wear or damage.
2. Check choke shaft (Nikki carburetor only) and throttle shaft for wear and free movement.

LPG/NG Carburetor - Reassembly

IMPCO Carburetor

NOTE: Clamp brackets and stop collar mounted on throttle shaft should still be in their original positions, and not require any readjustment/resetting. If mounted position of any one of these was affected or changed, it will be necessary to check and reset position of each before proceeding. Follow Instructions for Checking/Positioning Clamp Brackets Mounted on Throttle Shaft, then continue with steps 6 and 7.

1. Slide venturi into carburetor body, aligning position mark made prior to removal. Correctly installed, discharge holes should not be visible from top.
2. Secure with venturi retaining screw. Torque screw to 4.0 N·m (36 in. lb.).
3. Install a new adapter gasket and mount air cleaner adapter onto carburetor with screws. Torque screws to 4.0 N·m (36 in. lb.).
4. Install a new carburetor gasket onto intake manifold adapter, followed by carburetor. Install and finger tighten mounting fasteners.
5. Connect Z end of throttle linkage and dampening spring to throttle clamp bracket on throttle shaft. Attach opposite end of linkage and spring to governor lever.
6. Manually move governor lever toward carburetor as far as it will go.
7. Check that throttle plate is now fully open or reposition carburetor slightly on mounting hardware so it is fully open. Torque mounting screws or nuts to 6.2-7.3 N·m (55-65 in. lb.).

Nikki Carburetor

NOTE: If additional adjustment is required, loosen throttle linkage clamp bracket mounting screw, set throttle shaft to full throttle position against head of stop screw, and retighten clamp mounting screw securely.

1. Reinstall rear plug with a new sealing washer. Tighten plug securely.
2. Reinstall fuel transfer chamber cover with a new gasket. Secure with screws.

Fuel System

3. Install new carburetor mounting gasket on manifold studs, followed by carburetor and new air cleaner base gasket.
4. Reconnect throttle and choke linkages, and fuel and vacuum lines.
5. Reinstall air cleaner base and breather tube. Secure base with mounting nuts. Torque nuts to 9.9 N·m (88 in. lb.). Install rest of air cleaner system.
6. Check to be sure all system connections are tight.
7. Reset idle RPM and recheck high idle (governed speed) after starting and allowing sufficient warm-up time.

Instructions for Checking/Positioning Clamp Brackets Mounted on Throttle Shaft

Use only if position or mounting of clamp bracket(s) has been disturbed.

Idle Speed Clamp Bracket Position

1. Counting number of turns, back idle speed adjustment screw off (counterclockwise), so only 1 to 1 1/2 threads are visible.
2. Loosen clamp bracket mounting screw, and pivot throttle shaft to fully close throttle plate.
3. Hold throttle plate closed and rotate clamp bracket until end of screw contacts stop. Insert a 0.025 mm (0.001 in.) feeler gauge between carburetor housing and side of clamp bracket to set endplay, then tighten mounting screw securely.
4. Reset idle speed adjustment screw back to original position.

High Speed/Stop Collar Position

NOTE: After idle speed clamp bracket and high speed stop collar positions have been set, check that throttle shaft pivots freely without binding or restriction.

1. Make sure idle speed clamp position has already been checked or properly set.
2. Rotate and hold throttle shaft so throttle plate is fully open/perfectly vertical.
3. Insert a 0.025 mm (0.001 in.) feeler gauge between side of stop collar and carburetor housing, then check or set position of stop collar. Head of mounting screw must be in contact with carburetor boss from back (hose/fitting) side, preventing any further rotation over center. Set or adjust stop collar as required.
4. Tighten screw securely.

Throttle Linkage Clamp Bracket Position

Carburetor must be assembled to engine with linkage attached to set this position.

1. Throttle linkage clamp bracket should be positioned on idle speed clamp bracket side of throttle shaft.

2. Manually move governor lever, with throttle linkage connected, toward carburetor as far as it will go. Hold it in this position.
3. Looking down throat of carburetor, check that throttle plate is in full throttle position and that head of high speed collar stop screw is in contact with carburetor boss. If not, loosen carburetor mounting hardware and reposition carburetor slightly. Torque carburetor mounting screws or nuts to 6.2-7.3 N·m (55-65 in. lb.).

HIGH ALTITUDE OPERATION

Standard carburetor calibrations will provide proper operation up to altitudes of 1500 m (5000 ft.). No internal changes are necessary or available for either carburetor.

Idle Speed Adjustment

1. Start engine and run at half throttle for 5 to 10 minutes. Check that throttle and choke (Nikki carburetor) plates can open fully.
2. Place throttle control into idle or slow position. Turn low idle speed adjusting screw in or out, to obtain a low idle speed of 1200 RPM (\pm 75 RPM), or set to application specifications. Check speed using a tachometer.

ELECTRIC LOCK-OFF/FILTER ASSEMBLY

Electric Lock-off/Filter Components

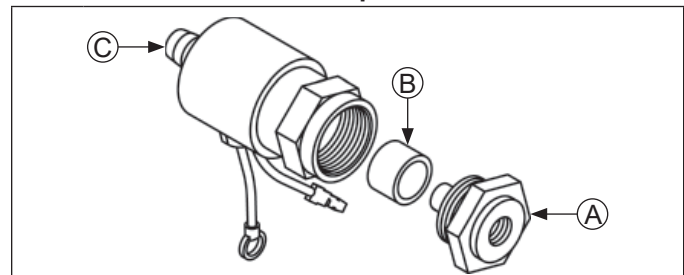

A	Inlet Fitting	B	Filter
C	Outlet Fitting		

Functional Test

Electric lock-off can be easily tested to verify that it is functional. Remove it from system for testing. Using a 12 volt power supply or battery, connect one wire lead to positive (+) lead of power supply, and touch remaining wire lead to negative (-) lead of power supply. When connection is made, an audible click should be heard indicating opening of lock-off. While energized, blow compressed air through it to determine if it is blocked or restricted.

Filter Service

Filter inside lock-off assembly should be replaced. Cleaning of filter element is not recommended. Order a replacement filter element by appropriate Rehlko part number.

VAPORIZER ASSEMBLY

Vaporizer Components

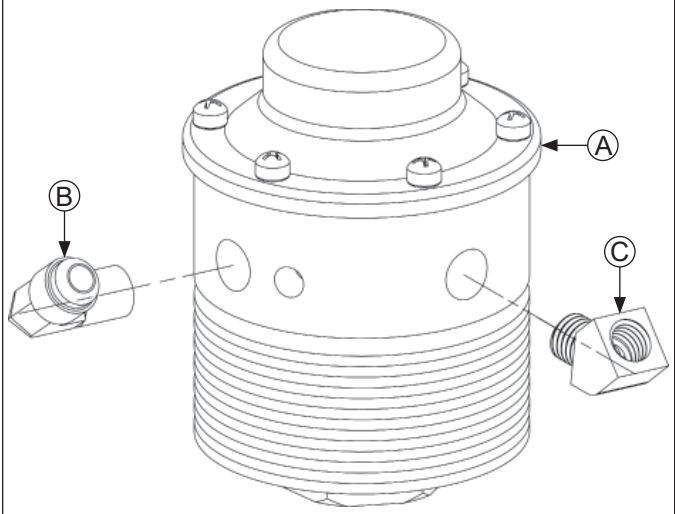

A	Vaporizer	B	Fitting
C	Elbow		

Outer surface of vaporizer should be kept free of dirt and debris accumulation, which will cause a loss of vaporization efficiency. Visual inspection and necessary cleaning should be performed on a regular basis, more frequently under dusty or dirty conditions.

LPG/NG REGULATOR

Regulator controls both pressure and flow of fuel within LPG/NG system. It is comprised of both a primary and secondary chamber, which are dependent upon one another. Two different styles of regulators are used, based upon system involved. Although basic design and operating principles are similar, due to system differences regulators should not be interchanged.

Following are separate sections covering theory of operation and general service information for each style of regulator. Detailed service/repair instructions are included in rebuild kit for each regulator.

IMPCO (Beam) Regulator

Details and Components

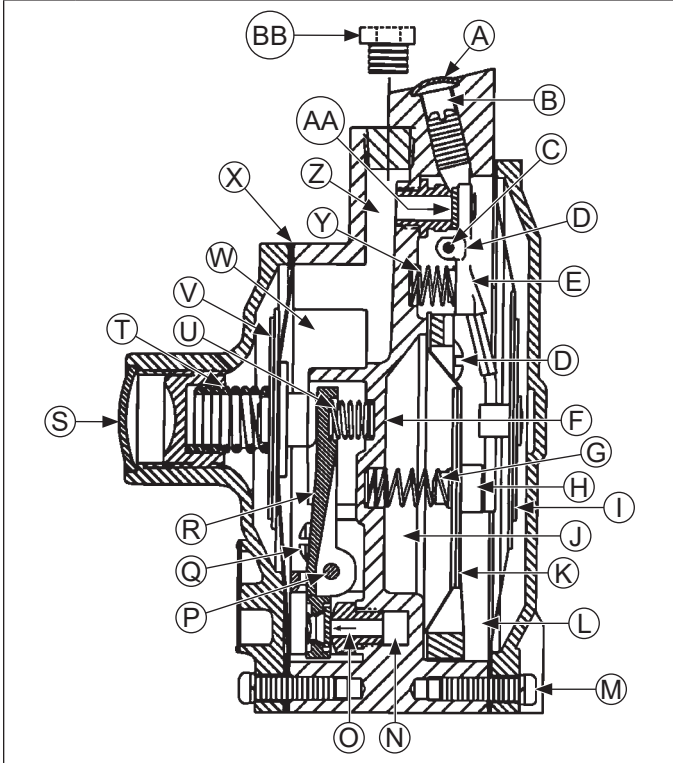

A	Expansion Plug	B	Adjustment Screw
C	Secondary Pivot Pin	D	Pan Head Screw
E	Secondary Lever Assembly	F	Floor
G	Vacuum Lock Spring	H	Bumper
I	Secondary Diaphragm	J	Vacuum Chamber
K	Vacuum Lock Diaphragm Assembly	L	Secondary Area
M	Torx Head Screw with Split Lock Washer	N	LPG/NG Entrance
O	LPG/NG Passage	P	Primary Pivot Pin
Q	Fillister Head Screw	R	Primary Lever Assembly
S	Expansion Plug	T	Primary Spring
U	Secondary Diaphragm Spring	V	Primary Diaphragm Assembly
W	LPG/NG Primary Area	X	Diaphragm Gasket
Y	Secondary Lever Spring	Z	Passage to Secondary Valve
AA	Secondary Valve	BB	1/8-27 NPT Plug

Fuel System

LPG/NG vapor enters regulator, then passes into primary area, where pressure is reduced from up to 1724 kPa (250 psi) at tank to 31 kPa (4.5 psi). Fuel pressure against diaphragm overcomes spring and as movement increases, spring will close lever. Primary diaphragm breather is vented to secondary chamber so that rupture of this diaphragm would direct fuel into carburetor.

Fuel now moves through passage, past secondary valve into secondary area. As negative pressure (vacuum) is created at carburetor venturi and is transmitted through dry-gas hose to chamber secondary diaphragm is drawn down and contacts secondary lever. Fuel will flow in proportion to air velocity through carburetor venturi, ensuring an ideal mixture at all engine speeds.

Whenever engine is operating, vacuum diaphragm is down against floor and spring is compressed. Idle and starting adjustment is made with a tamper-resistant screw which regulates whisker wire system, opening up secondary orifice slightly (but only when vacuum diaphragm is drawn down). Very little vacuum is needed to start this vacuum diaphragm travel: 0.2 in. Mercury to start and 0.5 in. Mercury for full travel. When engine stops rotating, loss of vacuum in section releases diaphragm causing bumper to push against secondary lever, overcoming action of whisker wire and ensuring 100% lock-off.

This patented Beam design will lock off primary pressures up to five times in excess of normal and permits starting without priming or choking.

Nikki Regulator

Primary Chamber Details and Components

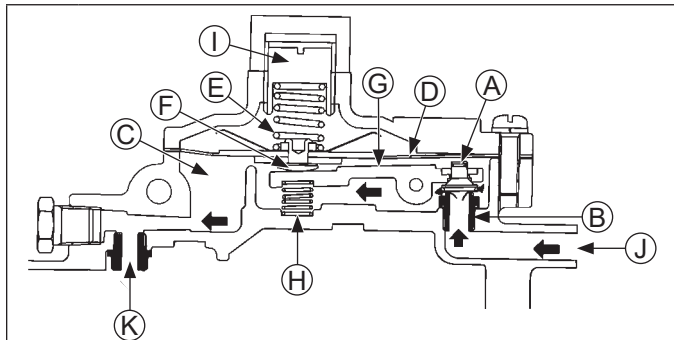

A	Primary Valve	B	Primary Valve Seat
C	Primary Chamber	D	Primary Diaphragm
E	Primary Diaphragm Spring Adjustment	F	Contact Button
G	Primary Valve Lever	H	Primary Lever Spring
I	Primary Pressure	J	Fuel Inlet
K	To Secondary Chamber		

Primary chamber reduces high pressure fuel flow from tank and vaporizer down to approximately 29 kPa (4 psi). Fuel flowing from vaporizer enters inlet of regulator under approximately 76 kPa (11 psi) of pressure. There it is delivered to primary chamber through clearance between primary valve and valve seat. As fuel continues to flow and primary chamber approaches 29 kPa (4 psi), primary diaphragm overcomes tension of diaphragm spring. As diaphragm and contact button move up, primary lever spring pushes primary lever up, in turn closing primary valve and stopping flow of fuel. As fuel is consumed and pressure in primary chamber drops below 29 kPa (4 psi), diaphragm spring tension will be greater than fuel pressure, causing primary diaphragm to be pushed down. This causes contact button, to push primary lever down, in turn opening primary valve and admitting more fuel. In this manner, pressure within primary chamber is maintained at a relatively constant 29 kPa (4 psi).

Secondary Chamber Details and Components

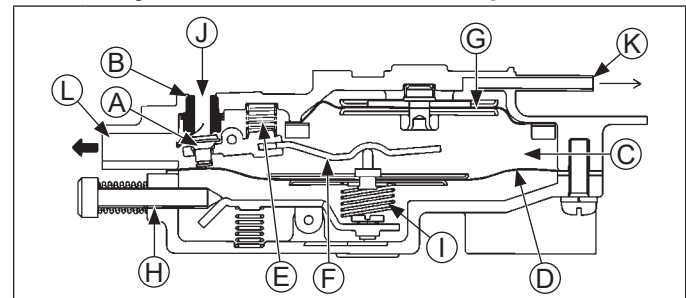

A	Secondary Valve	B	Secondary Valve Seat
C	Secondary Chamber	D	Secondary Diaphragm
E	Secondary Diaphragm Spring	F	Secondary Valve Lever
G	Vacuum Lock-off Diaphragm	H	Idle Adjust Screw
I	Balance Spring	J	From Primary Chamber
K	To Intake Manifold	L	To Carburetor

Secondary chamber further reduces fuel pressure from 29 kPa (4 psi) of primary chamber to near 0 kPa (0 psi) pressure, to prevent excessive fuel flow to carburetor. Fuel enters secondary chamber through clearance between secondary valve and valve seat. While engine is operating, and fuel is being drawn from secondary chamber, secondary diaphragm is raised by atmospheric pressure, simultaneously lifting secondary valve lever, opening secondary valve, allowing fuel to flow. When engine is running at idle, there may not be enough vacuum created in carburetor venturi to overcome tension of secondary diaphragm spring, and secondary diaphragm cannot open valve. Under those conditions, idle adjusting screw, and balance spring are used to apply just enough pressure on diaphragm to maintain sufficient fuel flow for idle operation.

Vacuum lock-off mechanism is located in secondary chamber. When engine is running, manifold vacuum above diaphragm draws it up, so secondary valve can function normally. When engine is stopped, manifold vacuum is terminated, and diaphragm relaxes and pushes down on secondary valve lever, preventing any fuel flow or leakage through regulator.

Preventative Maintenance

Regulator is preset at factory and generally requires no further adjustment. No periodic service is required. Over time, depending on fuel quality, operating environment, and system performance, fuel deposits can accumulate inside regulator. For Nikki regulators, perform following steps to remove any accumulated deposits.

1. Turn supply valve off, run engine out of fuel, and turn off ignition switch.
2. Disconnect and ground spark plug leads.
3. Remove 1/8 in. pipe plug from bottom of regulator and drain any accumulated deposits.
4. Reinstall plug using pipe sealant with Teflon[®] (Loctite[®] PST[®] 592[™] Thread Sealant or equivalent) on threads and tighten securely. If required, a replacement plug can be found at KohlerEngine.com.

Regulator Service

It is recommended that disassembly, cleaning, and resetting of regulator be performed using regulator rebuilding kit available at KohlerEngine.com. Specific instructions are included in rebuilding kit. Perform regulator service following instructions provided. As all adjustments and settings must be reset using specific test equipment, this must be performed by qualified LPG/NG personnel only.

Governor System

GOVERNOR

These engines are equipped with an electronic governor or a mechanical governor.

Governor Components

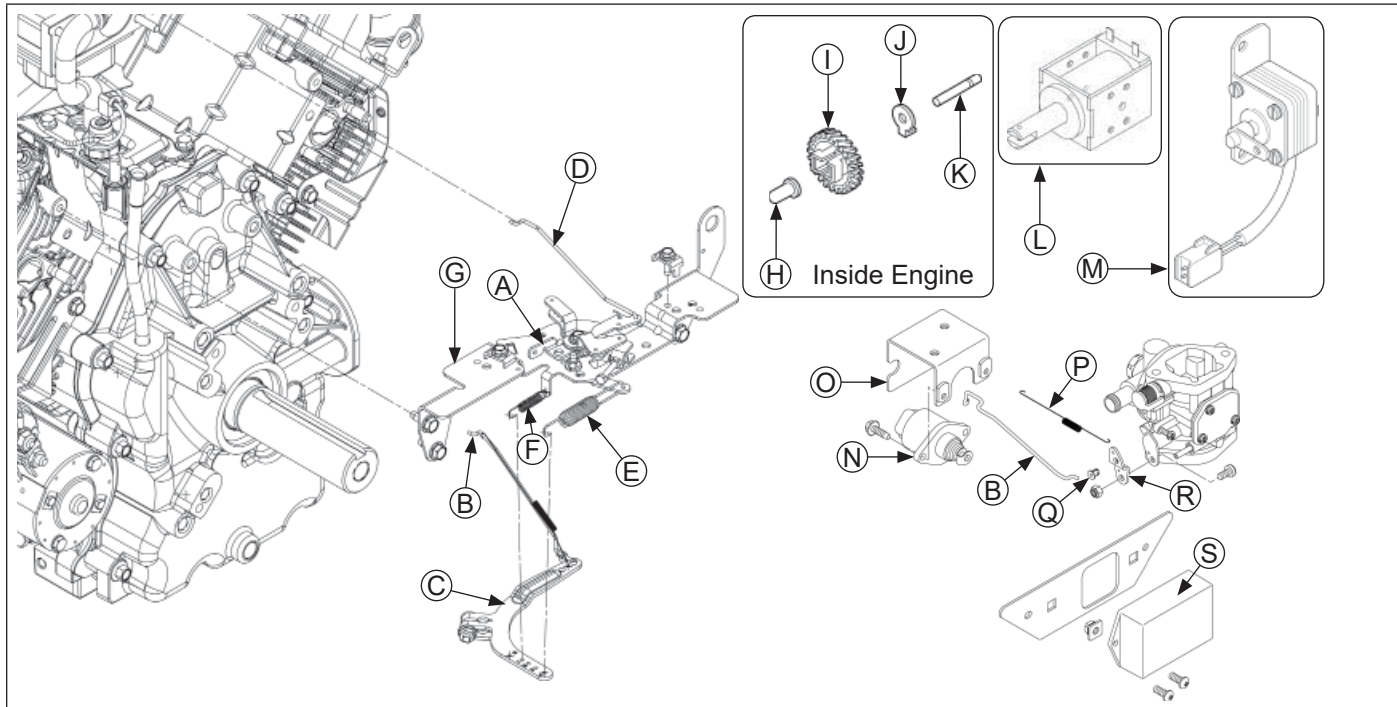

A	Throttle Lever	B	Throttle Linkage	C	Governor Lever	D	Choke Linkage
E	Governor Spring	F	Governed Idle Spring	G	Control Bracket	H	Regulating Pin
I	Governor Gear	J	Locking Tab Thrust Washer	K	Governor Gear Shaft	L	Idle Solenoid
M	Electronic Governor Assembly	N	Digital Linear Actuator (DLA)	O	DLA Bracket	P	Linkage Spring
Q	Linkage Retaining Bushing	R	Throttle Lever Adapter	S	Governor Control Unit (GCU)		

Mechanical Governor

Engine is equipped with a centrifugal flyweight mechanical governor. It is designed to hold engine speed constant under changing load conditions. Governor gear/flyweight mechanism is mounted inside crankcase on closure plate, and is driven off gear on camshaft.

This governor design works as follows:

- Centrifugal force acting on rotating governor gear assembly causes flyweights to move outward as speed increases. Governor spring tension moves them inward as speed decreases.
- As flyweights move outward, they cause regulating pin to move outward.
- Regulating pin contacts tab on cross shaft causing shaft to rotate. One end of cross shaft protrudes through crankcase. Rotating action of cross shaft is transmitted to throttle lever of carburetor through external linkage.
- When engine is at rest, and throttle is in FAST position, tension of governor spring holds throttle plate open. When engine is operating, governor gear assembly is rotating. Force applied by regulating pin against cross shaft tends to close throttle plate. Governor spring tension and force applied by

regulating pin balance each other during operation, to maintain engine speed.

- When load is applied and engine speed and governor gear speed decreases, governor spring tension moves governor lever to open throttle plate wider. This allows more fuel into engine, increasing engine speed. As speed reaches governed setting, governor spring tension and force applied by regulating pin will again offset each other to hold a steady engine speed.

Governor Adjustments

NOTE: Do not tamper with governor setting. Overspeed is hazardous and could cause personal injury.

Initial Adjustment Procedure

Make this adjustment whenever governor arm is loosened or removed from cross shaft. Adjust as follows:

1. Make sure throttle linkage is connected to governor arm and throttle lever on carburetor.
2. Loosen nut holding governor lever to cross shaft.
3. Move governor lever toward carburetor as far as it will go (wide open throttle) and hold in this position.

- Insert a long thin rod or tool into hole on cross shaft and rotate shaft counterclockwise (viewed from end) as far as it will turn, then torque nut to 6.8 N·m (60 in. lb.).

Sensitivity Adjustment

Governor sensitivity is adjusted by repositioning governor spring in holes of governor lever. If speed surging occurs with a change in engine load, governor is set too sensitive. If a big drop in speed occurs when normal load is applied, governor should be set for greater sensitivity and adjust as follows:

- To increase sensitivity, move spring closer to governor cross shaft.
- To decrease sensitivity, move spring away from governor cross shaft.

ELECTRONIC GOVERNOR

Two types of electronic governor have been used. One has an electronic governor assembly (rotary stepper motor) that secures near carburetor, with a throttle linkage that connects these two components. Other type has a digital linear actuator and governor control unit as explained below.

Electronic governor regulates engine speed at varying loads. Typical electronic governor includes:

- Digital linear actuator.
- Throttle linkage.
- Linkage spring.
- Choke linkage.
- Throttle lever adapter.
- Governor Control Unit.

Digital Linear Actuator (DLA)

Energizing bi-directional digital linear actuator coils in proper sequence, causes threaded shaft to move out of, or back into rotor, in precise linear increments. When power is removed, actuator shaft remains in position. DLA must initialize (fully extend) to move throttle plate to closed position, and partially open for starting. Correct adjustment of DLA is critical to achieve full range of throttle plate movement. See Adjustment.

Governor control unit (GCU) senses engine speed by pulse voltage inputs from ignition modules. GCU regulates engine speed by variable input voltage from a customer-supplied potentiometer or a single pole, single throw (SPST) switch.

NOTE: Actual speeds depend on application. Refer to equipment manufacturer's recommendations.

Potentiometer Specifications

Wiper Voltage	Engine Speed (RPM)
0-1	Low Speed Endpoint
1-9	Variable Speed Endpoint
9-16	High Speed Endpoint

SPST Switch Specifications

Switch Position	Engine Speed (RPM)
Open	Low Speed Endpoint
Closed	High Speed Endpoint

GCU Safety Features

In event of an engine overspeed condition, GCU will shut down engine by grounding ignition modules.

GCU will shut down engine by grounding ignition when power to GCU is lost.

Linkage

Throttle linkage spring will fully open throttle plate if linkage becomes detached from DLA. This will create an overspeed condition causing engine to shut down. DLA shaft will have to be manually screwed back into body, and then retracted before reassembling linkage.

Adjustment

DLA must be in fully retracted position during assembly. Full range of throttle plate movement will not be achieved if DLA is partially extended when assembled. Loosen DLA mounting plate screws located on top of actuator plate. With throttle linkage centered in U-Clip or secured with a retaining clip at end of DLA shaft, slide DLA bracket assembly back until throttle plate is fully open. Torque mounting plate screws to 2.5 N·m (22 in. lb.).

Troubleshooting

Engine Starts But Will Not Continue to Run

- Check linkage connection between DLA and throttle plate.
- Verify DLA initializes when power is supplied (key switch in start or run position).
- Test potentiometer wiper output voltage (if equipped).
- Test SPST switch (if equipped).
- Check wire harness and connections.

Engine Does Not Run At Expected Speed

- Check to see that throttle linkage and DLA have full range of motion having no mechanical interference.
- Test potentiometer wiper voltage (if equipped).
- Test SPST switch (if equipped).

Lubrication System

This engine uses a full pressure lubrication system which delivers oil under pressure to crankshaft, camshaft, connecting rod bearing surfaces, and hydraulic valve lifters.

A high-efficiency gerotor oil pump maintains high oil flow and oil pressure, even at low speeds and high operating temperatures. A pressure relief valve limits maximum pressure of system. Closure plate must be removed to service oil pickup, pressure relief valve, and oil pump.

Lubrication Components

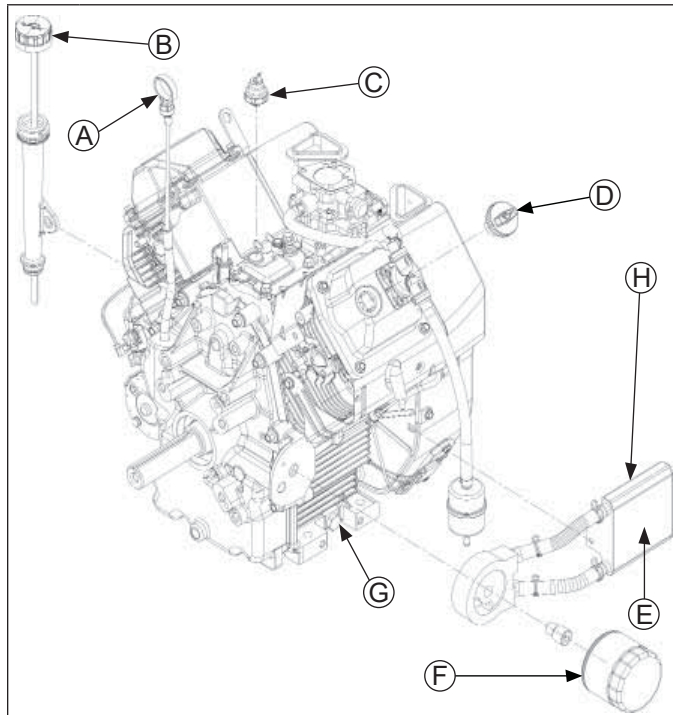

A	Press-In Dipstick	B	Thread-On Dipstick
C	Oil Sentry™	D	Oil Fill Cap
E	Oil Cooler	F	Oil Filter
G	Oil Drain Plug	H	Back Side

OIL RECOMMENDATIONS

Refer to Maintenance.

CHECK OIL LEVEL

NOTE: To prevent extensive engine wear or damage, never run engine with oil level below or above operating range indicator on dipstick.

Ensure engine is cool. Clean oil fill/dipstick areas of any debris.

- Remove dipstick; wipe oil off.
 - Press-in cap: reinsert dipstick into tube; press completely down.

or

 - Thread-on cap: reinsert dipstick into tube; rest cap on tube, do not thread cap onto tube.
- Remove dipstick; check oil level. Level should be at top of indicator on dipstick.
- If oil is low on indicator, add oil up to top of indicator mark.

- Reinstall dipstick and tighten securely.

CHANGE OIL AND FILTER

Change oil while engine is warm.

- Clean area around oil fill cap/dipstick, drain plug/oil drain valve.
 - Remove drain plug and oil fill cap/dipstick. Allow oil to drain completely.

or

 - Open oil drain valve cap; if needed, attach a length of 1/2 in. I.D. hose to direct oil into appropriate container; twist valve drain body counterclockwise and pull. Remove dipstick. Allow oil to drain completely.
- Clean area around oil filter. Place a container under filter to catch any oil and remove filter. Wipe off mounting surface.
 - Reinstall drain plug. Torque to 13.6 N·m (10 ft. lb.).

or

 - Close oil drain valve body, remove hose (if used), and replace cap.
- Place new filter in shallow pan with open end up. Fill with new oil until oil reaches bottom of threads. Allow 2 minutes for oil to be absorbed by filter material.
- Apply a thin film of clean oil to rubber gasket on new filter.
- Refer to instructions on oil filter for proper installation.
- Fill crankcase with new oil. Level should be at top of indicator on dipstick.
- Reinstall oil fill cap/dipstick and tighten securely.
- Start engine; check for oil leaks. Stop engine; correct leaks. Recheck oil level.
- Dispose of used oil and filter in accordance with local ordinances.

OIL COOLER (if equipped)

Blower Housing Mounted Oil Cooler

- Clean fins with a brush or compressed air.
- Remove screws securing oil cooler and tilt to clean back side.
- Reinstall oil cooler.

Crankcase Mounted Oil Cooler

Clean fins with a brush or compressed air.

OIL SENTRY™ (if equipped)

This switch is designed to prevent engine from starting in a low oil or no oil condition. Oil Sentry™ may not shut down a running engine before damage occurs. In some applications this switch may activate a warning signal. Read your equipment manuals for more information.

Oil Sentry™ pressure switch is installed in breather cover. On engines not equipped with Oil Sentry™ installation hole is sealed with a 1/8-27 N.P.T.F. pipe plug.

Installation

1. Apply pipe sealant with Teflon® (Loctite® PST® 592™ Thread Sealant or equivalent) to threads of switch.
2. Install switch into tapped hole in breather cover.
3. Torque switch to 4.5 N·m (40 in. lb.).

Testing

Compressed air, a pressure regulator, pressure gauge, and a continuity tester are required to test switch.

1. Connect continuity tester across blade terminal and metal case of switch. With 0 psi pressure applied to switch, tester should indicate continuity (switch closed).
2. Gradually increase pressure to switch. As pressure increases through range of 3-5 psi tester should indicate a change to no continuity (switch open). Switch should remain open as pressure is increased to 90 psi maximum.
3. Gradually decrease pressure through range of 3-5 psi. Tester should indicate a change to continuity (switch closed) down to 0 psi.
4. Replace switch if it does not operate as specified.

Electrical System

SPARK PLUGS

	⚠ CAUTION
	Electrical Shock can cause injury. Do not touch wires while engine is running.

Spark Plug Component and Details

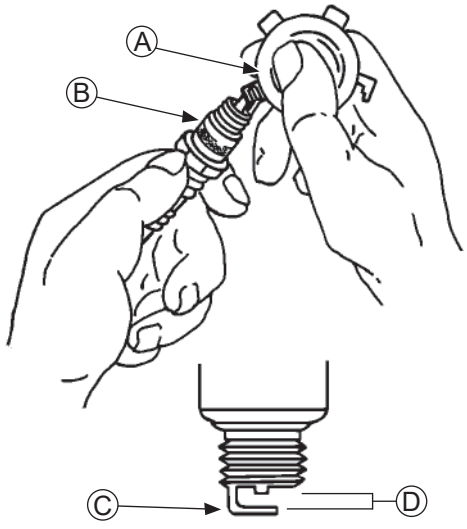

A	Wire Gauge	B	Spark Plug
C	Ground Electrode	D	Gap

NOTE: Do not clean spark plug in a machine using abrasive grit. Some grit could remain in spark plug and enter engine causing extensive wear and damage.

Engine misfire or starting problems are often caused by a spark plug that has improper gap or is in poor condition.

Engine is equipped with following spark plugs:

Gap	0.76 mm (0.030 in.) all except NG CD Fixed
	0.51 mm (0.020 in.) NG CD Fixed
Thread Size	14 mm
Reach	19.1 mm (3/4 in.)
Hex Size	15.9 mm (5/8 in.)

Refer to Maintenance for Repairs/Service Parts.

Service

Clean out spark plug recess. Remove plug and replace.

1. Check gap using wire feeler gauge. Adjust gap to 0.76 mm (0.030 in.) for all except NG with CD fixed timing or 0.51 mm (0.020 in.) for NG with CD fixed timing.
2. Install plug into cylinder head.
3. Torque plug to 27 N·m (20 ft. lb.).

Inspection

Inspect each spark plug as it is removed from cylinder head. Deposits on tip are an indication of general condition of piston rings, valves, and carburetor.

Normal and fouled plugs are shown in following photos:

Normal

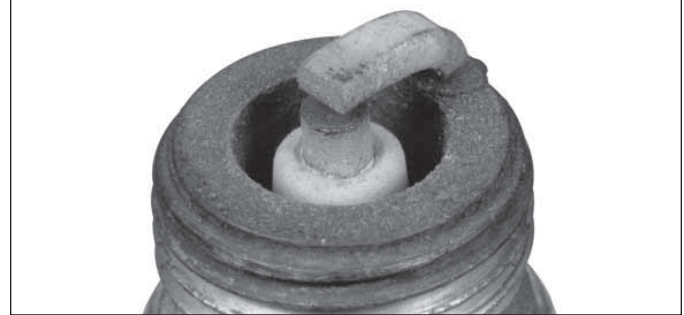

Plug taken from an engine operating under normal conditions will have light tan or gray colored deposits. If center electrode is not worn, plug can be set to proper gap and reused.

Worn



On a worn plug, center electrode will be rounded and gap will be greater than specified gap. Replace a worn spark plug immediately.

Wet Fouled



A wet plug is caused by excess fuel or oil in combustion chamber. Excess fuel could be caused by a restricted air cleaner, a carburetor problem, or operating engine with too much choke. Oil in combustion chamber is usually caused by a restricted air cleaner, a breather problem, worn piston rings, or valve guides.

Carbon Fouled



Soft, sooty, black deposits indicate incomplete combustion caused by a restricted air cleaner, over rich carburetion, weak ignition, or poor compression.

Overheated



Chalky, white deposits indicate very high combustion temperatures. This condition is usually accompanied by excessive gap erosion. Lean carburetor settings, an intake air leak, or incorrect spark timing are normal causes for high combustion temperatures.

BATTERY

A 12-volt battery with 400 cold cranking amps (cca) is generally recommended for starting in all conditions. A smaller capacity battery is often sufficient if an application is started only in warmer temperatures. Refer to following table for minimum capacities based on anticipated ambient temperatures. Actual cold cranking requirement depends on engine size, application, and starting temperatures. Cranking requirements increase as temperatures decrease and battery capacity shrinks. Refer to equipment's operating instructions for specific battery requirements.

Battery Size Recommendations

Temperature	Battery Required
Above 32°F (0°C)	200 cca minimum
0°F to 32°F (-18°C to 0°C)	250 cca minimum
-5°F to 0°F (-21°C to -18°C)	300 cca minimum
-10°F (-23°C) or below	400 cca minimum

If battery charge is insufficient to turn over engine, recharge battery.

Battery Maintenance

Regular maintenance is necessary to prolong battery life.

Battery Test

To test battery, follow manufacturer's instructions.

ELECTRONIC IGNITION SYSTEMS

Ignition System Components

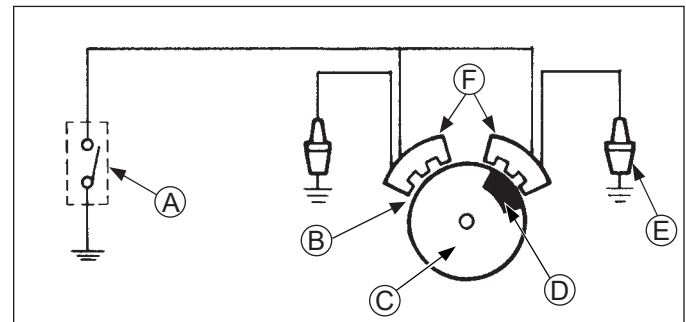

A	Kill Switch/ Off Position of Key Switch	B	Air Gap
C	Flywheel	D	Magnet
E	Spark Plug	F	Ignition Modules

There are 3 different types of ignition systems used on these engines. All systems use an ignition module which energizes spark plug. Difference in systems is in way ignition timing is triggered.

All ignition systems are designed to be trouble free for life of engine. Other than periodically checking/replacing spark plugs, no maintenance or timing adjustments are necessary or possible. Mechanical systems do occasionally fail or break down. Refer to Troubleshooting to determine root of a reported problem.

Reported ignition problems are most often due to poor connections. Before beginning test procedure, check all external wiring. Be certain all ignition-related wires are connected, including spark plug leads. Be certain all terminal connections fit snugly. Make sure ignition switch is in run position.

Electrical System

Wiring Diagram-15/20/25 Amp Regulated Battery Charging System with Fixed Timing

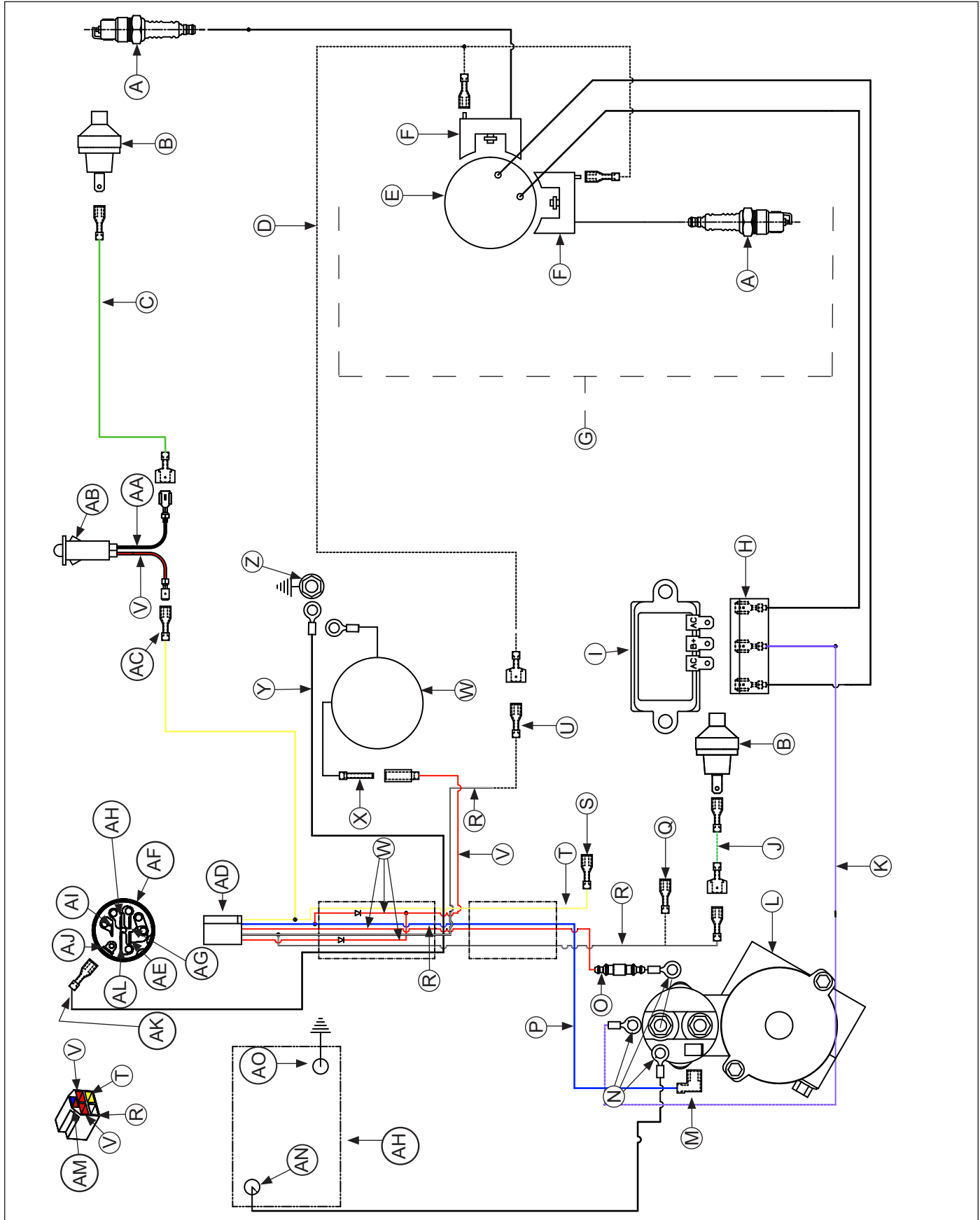

Fixed Ignition System

This system uses a capacitive discharge (CD) coil. Ignition timing and spark remains constant regardless of engine speed. Timing of spark is controlled by location of flywheel magnet group as referenced to engine TDC. A typical fixed ignition system consists of:

- 1 magnet assembly which is permanently affixed to flywheel.
- 2 electronic capacitive-discharge ignition modules which mount on engine crankcase.
- 1 kill switch (or key switch) which grounds modules to stop engine.
- 2 spark plugs.

A	Spark Plug(s)	B	Oil Pressure Switch	C	Oil Sentry™ (Green)	D	White Kill
E	Flywheel Stator Assembly	F	Ignition Module	G	Non-Smart Spark™ Ignition	H	Rectifier-Regulator Connector
I	Rectifier-Regulator	J	Oil Sentry™ Kill (Green)	K	Violet B+	L	Solenoid Shift Starter Assembly
M	Starter Solenoid Tang	N	Starter Solenoid Stud	O	Fuse	P	Blue
Q	Alternate Ignition Kill (-)	R	White	S	Accessory Terminal (+)	T	Yellow
U	Ignition Kill	V	Red	W	Carburetor	X	Carburetor Solenoid
Y	Black (Ground)	Z	Intake Manifold Screw	AA	Black	AB	Oil Sentry™ Panel Light/Remote Light
AC	Oil Sentry™ Light	AD	Connector	AE	Magneto	AF	Key Switch
AG	Accessory	AH	Battery	AI	Starter	AJ	Ground
AK	Key Switch Ground	AL	Rectifier	AM	Blue/Red	AN	Battery Positive
AO	Battery Negative						

Electrical System

Wiring Diagram-15/20/25 Amp Regulated Battery Charging System with Variable Ignition Timing SMART-SPARK™

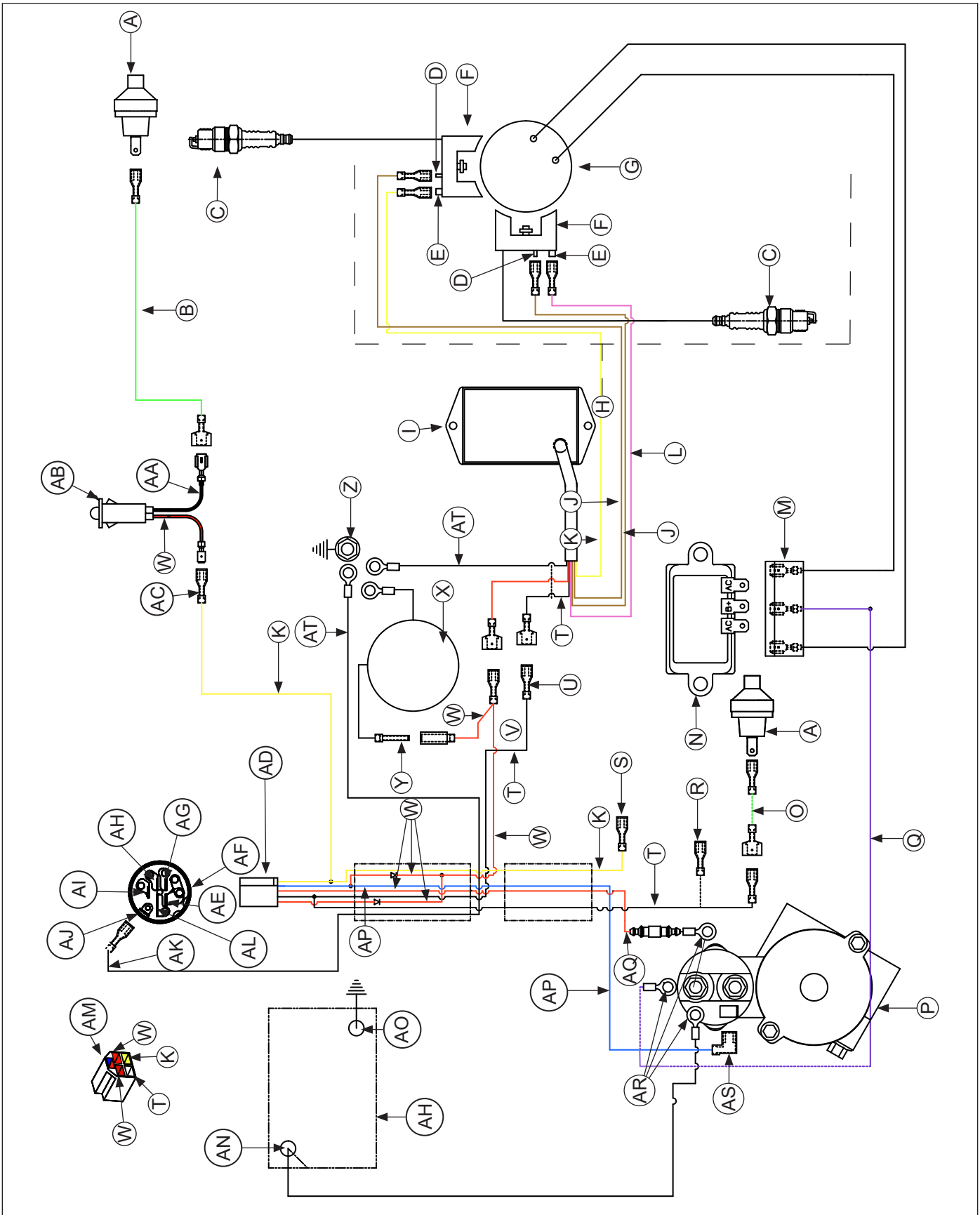

Smart-Spark™ Advance Ignition System

SMART-SPARK™ equipped engines utilize an electronic capacitive discharge ignition system with electronic spark advance. A typical application consists of following components:

- 1 magnet assembly which is permanently affixed to flywheel.
- 2 electronic capacitive discharge ignition modules which mount on engine crankcase.
- 1 spark advance module which mounts to engine shrouding.
- 1 12 volt battery which supplies current to spark advance module.
- 1 kill switch (or key switch) which grounds spark advance module to stop engine.
- 2 spark plugs.

A	Oil Pressure Switch	B	Oil Sentry™ (Green)	C	Spark Plug(s)	D	Kill
E	Trigger	F	Ignition Module	G	Flywheel Stator Assembly	H	22, 25 HP Smart-Spark™ Ignition
I	Module Speed Advance 22, 25 HP	J	Brown	K	Yellow	L	Yellow on Analog SAMs Pink on Digital SAMs
M	Rectifier-Regulator Connector	N	Rectifier-Regulator	O	Oil Sentry™ Kill (Green)	P	Solenoid Shift Starter Assembly
Q	Violet (B+)	R	Alternate Ignition Kill (-)	S	Accessory Terminal (+)	T	White
U	Ignition Kill	V	Smart-Spark™	W	Red	X	Carburetor
Y	Solenoid Lead	Z	Intake Manifold Screw	AA	Black	AB	Oil Sentry™ Panel Light/Remote Light
AC	Oil Sentry™ Light	AD	Connector	AE	Magneto	AF	Key Switch
AG	Accessory	AH	Battery	AI	Starter	AJ	Ground
AK	Key Switch Ground	AL	Rectifier	AM	Blue/Red	AN	Battery Positive
AO	Battery Negative	AP	Blue	AQ	Fuse	AR	Starter Solenoid Stud
AS	Starter Solenoid Tang	AT	Black (Ground)				

Electrical System

Wiring Diagram-15/20/25 Amp Regulated Battery Charging System with DSAI Ignition and Key Switch

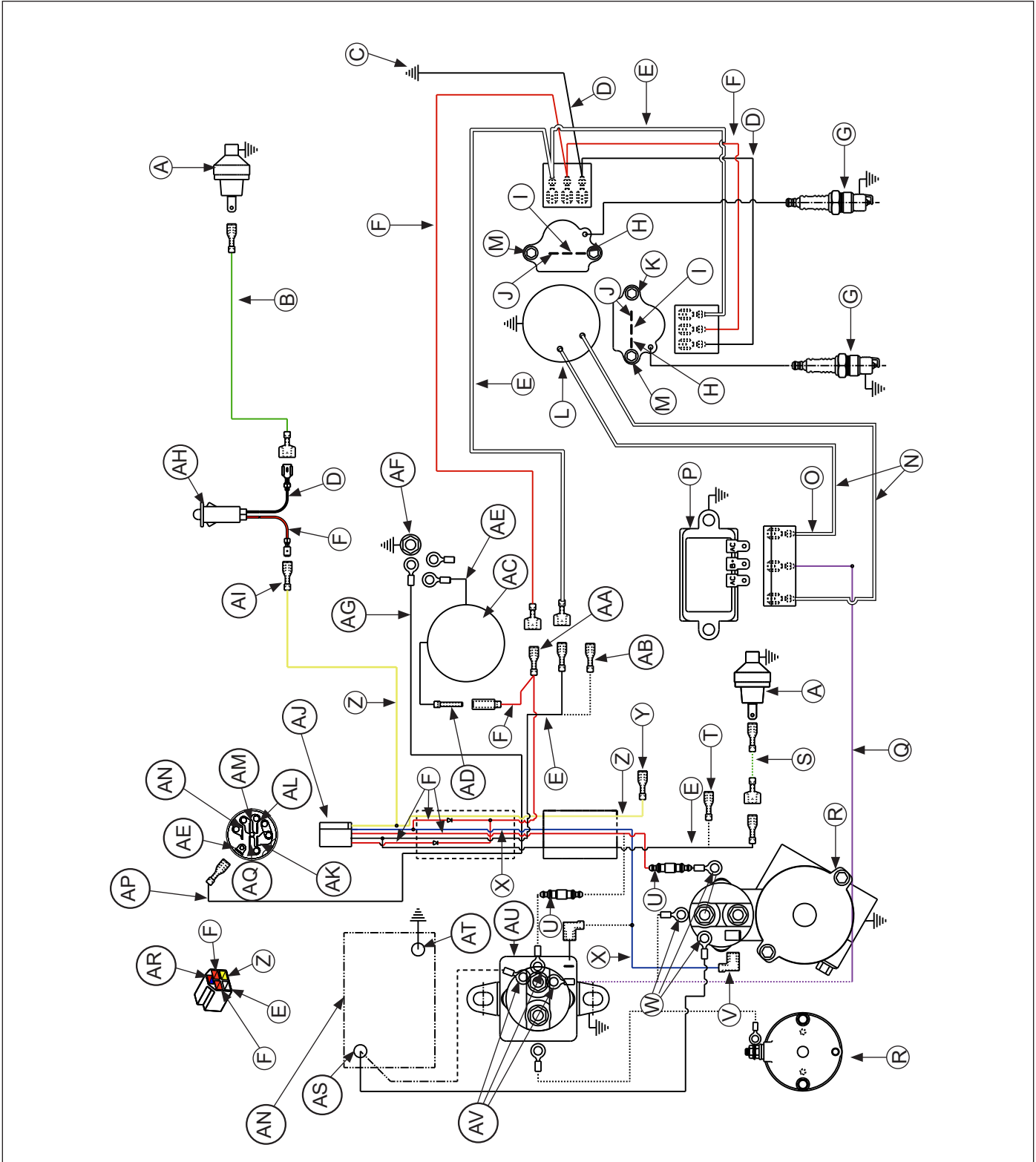

Digital Spark Advance Ignition (DSAI) System

This system uses a digital microprocessor which is located in ignition modules. Ignition timing varies depending upon engine speed with this system. There are 2 inductive-style ignition modules that control ignition timing based on engine RPM. A typical DSAI application consists of:

- 1 magnet assembly, which is permanently affixed to flywheel.
- 2 inductive, 12-volt ignition modules, which mount on engine crankcase.
- 1 12-volt battery, which supplies current to ignition modules.
- 1 kill switch (or key switch) which grounds spark advance module to stop engine.
- 2 spark plugs.

A	Oil Pressure Switch	B	Green (Oil Sentry™ Pulse Signal Lead)	C	Black (Ground) Intake Manifold Mounting Screw	D	Black
E	White	F	Red	G	Spark Plug(s)	H	Black (Ground)
I	Red (B+)	J	White (DSAI Kill)	K	Module Screw	L	Flywheel Stator Assembly
M	DSAI Module	N	White (AC Charging Leads)	O	Rectifier-Regulator Connector	P	Rectifier-Regulator
Q	Violet (B+ Lead)	R	Starter Assembly	S	Oil Sentry™ Pulse Signal	T	Alternate Ignition Pulse Signal (-)
U	Fuse	V	Starter Solenoid Tang	W	Starter Solenoid Stud	X	Blue
Y	Accessory Terminal (+)	Z	Yellow	AA	Red (DSAI Power)	AB	White (DSAI Kill)
AC	Carburetor	AD	Solenoid Lead	AE	Ground	AF	Intake Manifold Screw
AG	Black (Ground)	AH	Oil Sentry™ Panel Light/Remote Light	AI	Oil Sentry™ Light	AJ	Connector
AK	Magneto	AL	Key Switch	AM	Accessory	AN	Battery
AO	Starter	AP	Key Switch Ground (Black)	AQ	Rectifier	AR	Blue/Red
AS	Battery Positive	AT	Battery Negative	AU	Customer Supplied Relay Cranking	AV	Relay Stud

Electrical System

Wiring Diagram-3 Amp Unregulated Battery Charging System/70 Watt Lighting

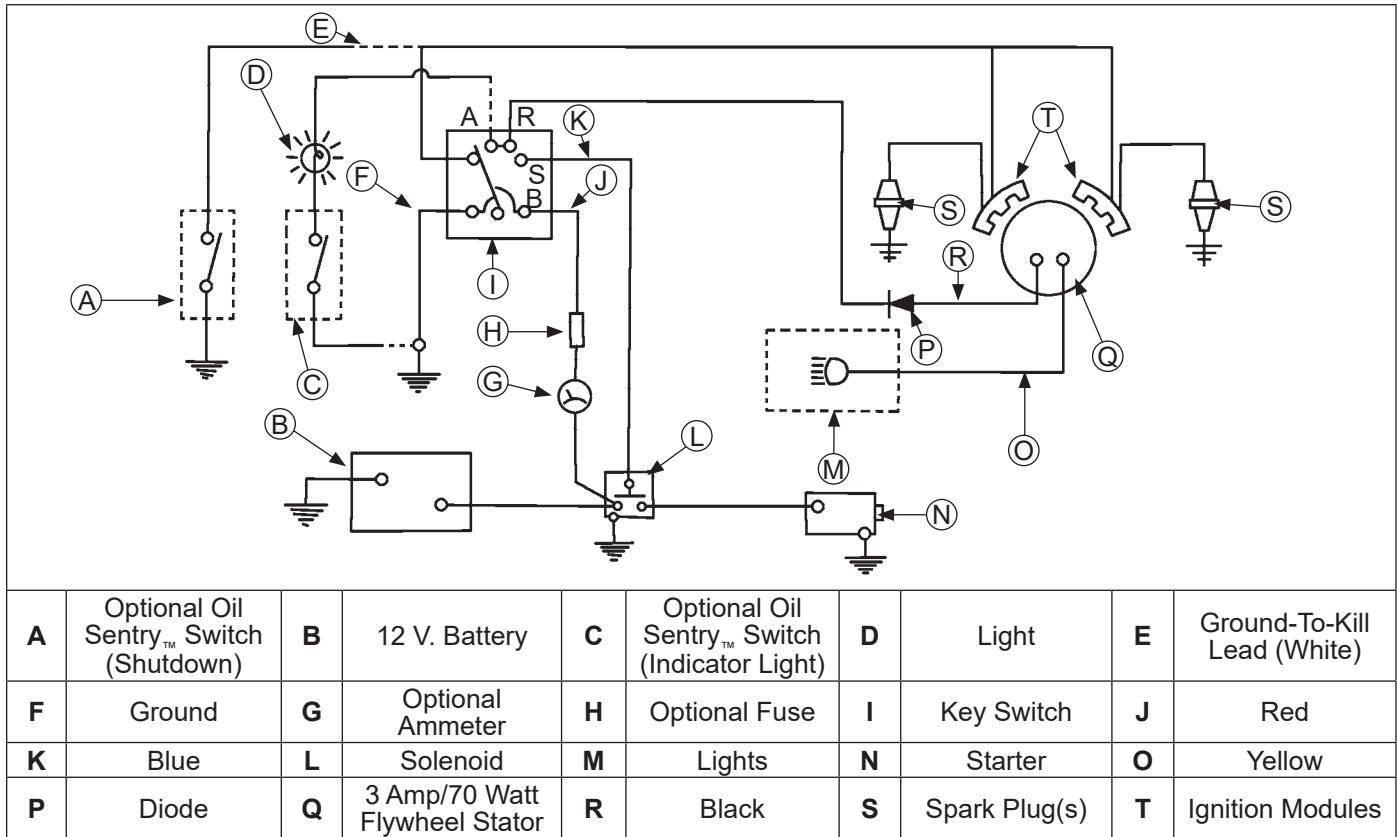

Electronic Ignition Systems Tests

NOTE: Ignition tester must be used to test ignition on these engines. Use of any other tester can result in inaccurate findings. Battery on unit must be fully charged and properly connected before performing tests (a battery that is hooked up or charged backward will crank engine but it won't have spark). Be certain drive is in neutral and all external loads are disconnected.

Test Ignition Systems

NOTE: If engine starts or runs during testing, you may need to ground kill lead to shut it down. Because you have interrupted kill circuit, it may not stop using switch.

Isolate and verify trouble is within engine.

1. Locate connectors where wiring harnesses from engine and equipment are joined. Separate connectors and remove white kill lead from engine connector. Rejoin connectors and position or insulate kill lead terminal so it cannot touch ground. Try to start engine to verify whether reported problem is still present.

Condition	Possible Cause	Conclusion
Problem goes away.	Electrical System	Check key switch, wires, connections, safety interlocks, etc.
Problem persists.	Ignition or Electrical System	Leave kill lead isolated until all testing is completed. Identify white kill lead of engine wiring harness connector. Establish a connection to a known good ground location. Engine should kill completely. If not or only one cylinder is affected, test ignition modules and white kill lead connection for affected DSAI module (DSAI only).

Test for Spark

NOTE: If 2 testers are available, testing can be performed simultaneously for both cylinders. However, if only 1 tester is available, 2 individual tests must be performed. Side not being tested must have spark plug lead connected or grounded. Do not crank engine or perform tests with 1 spark plug lead disconnected and not grounded, or permanent system damage may occur.

1. With engine stopped, disconnect 1 spark plug lead. Connect spark plug lead to post terminal of spark tester and attach tester clip to a good engine ground.
2. Crank engine over, establishing a minimum of 550-600 RPM, and observe tester(s) for spark.
3. Repeat spark test on opposite cylinder if cylinders are being tested individually.

Condition	Possible Cause	Conclusion
Both cylinders have good spark but engine runs poorly or existing plug condition is questionable.	Spark Plug(s)	Install new spark plug(s) and retest engine performance. If problem persists, check for timing advance (DSAI and Smart-Spark™ only).
1 cylinder has good spark and other cylinder has no or intermittent spark.	Ignition	Test ignition modules and connections (DSAI and Smart-Spark™ only).
Spark on both cylinders but power is suspect.	Timing Advance	Check for timing advance (DSAI and Smart-Spark™ only).

Test Timing Advance (DSAI and Smart-Spark™ only)

1. Make a line near edge of flywheel screen with a marking pen, chalk, or narrow tape.
2. Connect an automotive timing light to cylinder that had good spark.
3. Run engine at idle and use timing light beam to locate line on screen. Draw a line on blower housing next to line on screen. Accelerate to full throttle and watch for movement of line on screen relative to line on blower housing. If both cylinders had good spark, repeat test on other cylinder.

Condition	Possible Cause	Conclusion
Line on screen did not move away from line on blower housing during acceleration.	Ignition	Test ignition modules and connections.
Lines made on blower housing not 90° apart.		

Test Ignition Modules and Connections (DSAI only)

1. Remove blower housing from engine. Inspect wiring for any damage, cuts, bad crimps, loose terminals, or broken wires. Check that connections are oriented properly on terminals of modules.
2. Disconnect leads from ignition module(s) and clean all of terminals (male and female) with aerosol electrical contact cleaner to remove any old dielectric compound, dark residue, dirt, or contamination. Disconnect spark plug leads from spark plugs.
3. Using a multi-meter, check that a proper ground is established between ground (black) lead of DSAI module (closest to spark plug lead) and a known good ground location on engine.
4. Turn key switch to ON position and check for 12 volts at center/power (red) lead terminal of DSAI module. Use same ground location for multi-meter as in checking for timing advance.

Condition	Possible Cause	Conclusion
All tests are OK but module has no spark or fails to advance.	Ignition Module	Replace affected module.
Any test is BAD.	Ignition Module or Connections	Determine cause and fix as required; retest.

Electrical System

Test Ignition Modules and Connections (Smart-Spark™ only)

NOTE: Resistance values apply only to modules that have been on a running engine. New service modules may have higher resistance until they have been run.

1. Remove blower housing from engine. Inspect wiring for any damage, cuts, bad crimps, loose terminals, or broken wires.
2. Disconnect leads from ignition module(s) and clean all of terminals (male and female) with aerosol electrical contact cleaner to remove any old dielectric compound, dark residue, dirt, or contamination. Disconnect spark plug leads from spark plugs.
3. Remove one mounting screw from each ignition module. If mounting screws are black, remove them both and discard. Look in mounting hole with a flashlight and use a small round wire brush to remove any loose rust from laminations inside mounting hole.
4. Use a digital ohmmeter to check resistance values and compare them to ignition module resistance table. When testing resistance to laminations, touch probe to laminations inside screw hole, as some laminations have a rust preventative coating on surface which could alter resistance reading.

Ignition Module Resistance Table

24 584 03 or 24 584 11 (1 11/16 in. High)	24 584 15-S or 24 584 36-S (2 1/16 in. High)		
Test (Use Digital Ohmmeter)	From No. 1 to 4	From No. 2 to 4	From No. 3 to 4
24 584 03 24 584 11 (1 11/16 in. H)	945 to 1175 ohms	149 to 166 ohms	3750 to 7000 ohms
24 584 15-S (2 1/16 in. H)	890 to 1175 ohms	119 to 136 ohms	5600 to 9000 ohms
24 584 36-S (2 1/16 in. H)	590 to 616 ohms	183 to 208 ohms	8000 to 40,000 ohms

Condition	Possible Cause	Conclusion
All resistance values are within ranges specified in table.	Ignition Module Gap	Check and adjust ignition module gap.
At least 1 resistance value is not within ranges specified in table.	Ignition Module	Ignition module is faulty and should be replaced.

5. Check and/or adjust ignition module air gap(s). An air gap of 0.28/0.33 mm (0.011/0.013 in.) must be maintained under all three legs of ignition module(s). Checking/adjusting should be performed with parts at room temperature.

Condition	Possible Cause	Conclusion
Module was not loosened or replaced.	Ignition Module Air Gap	Check that specified air gap is present under all three legs. If gap is correct, reinstall second mounting screw removed earlier and recheck gap after tightening.
Module was loosened or replaced.	Ignition Module	Adjust ignition module air gap.

a. Adjust ignition module air gap.

1. Turn flywheel magnet away from module position.
2. Attach module to mounting legs, pull it away from flywheel, and tighten screws to hold it temporarily.
3. Rotate flywheel so magnet is centered under module.
4. Position a 0.30 mm (0.012 in.) feeler gauge between magnet and all three legs of module. Ignition module air gap is critical to proper system performance. Do not attempt to set it with a business card or folded microfiche card. Use feeler gauge specified.
5. Loosen mounting screws, allow magnet to pull module down against feeler gauge, and retighten mounting screws.
6. Rotate flywheel to remove feeler gauge, position magnet back under module, and recheck that specified gap, minimum of 0.28 mm (0.011 in.), exists under each leg of module. When you are certain gap is correct, torque module mounting screws to 4.0 N·m (35 in. lb.). Repeat these 6 steps to set other ignition module.
6. Reattach lead wires to ignition module(s), noting if resistance is felt, indicating a snug fit between male and female terminals. If any connections do not feel snug, disconnect lead, lightly pinch female terminal with a pliers, and recheck fit.
7. When integrity of all connections has been verified, retest for spark.

Condition	Possible Cause	Conclusion
Strong, steady spark is now present on both sides.	SAM	Problem should be corrected. Go to Test SAM step 4.
Still a spark problem.	SAM	Test SAM.

Test SAM

1. Trace red power source lead from SAM to harness connection. Separate connector and connect red lead of a DC voltmeter to harness terminal. Trace ground lead from SAM (black on singles, green on twins) to grounding screw. Connect black voltmeter lead to eyelet terminal of ground lead or ground screw/bolt. Check voltage with key switch in both START and RUN positions. A minimum of 7.25 volts must be present.
 - a. If correct voltage is not measured, connect black voltmeter lead directly to negative (–) post of battery and test voltage again in both key positions. If correct voltage is now indicated, check ground circuit connections. If ground screw/bolt or any other fasteners in ground circuit are black (oxide-coated), replace them with zinc plated (silver colored) fasteners.
 - b. If correct voltage is still not indicated, check harness connector terminal for a good connection and crimp to lead. Then trace power source circuit back through harness, key switch, etc., looking for any poor connections, or faulty circuits.

Condition	Possible Cause	Conclusion
Incorrect voltage is measured.	Voltage	Connect black voltmeter lead directly to negative (–) post of battery and test voltage again in both key positions. If correct voltage is still not indicated, check harness connector terminal for a good connection and crimp to lead. Then trace power source circuit back through harness, key switch, etc., looking for any poor connections, or faulty circuits.
Correct voltage is measured.	Voltage	Check ground circuit connections. If ground screw/bolt or any other fasteners in ground circuit are black (oxide-coated), replace them with zinc plated (silver colored) fasteners.

2. Disconnect all SAM leads, isolating it from engine. Test SAM according to style with tester 25 761 21-S (tests ASAM style modules only), or tester 25 761 40-S (tests both ASAM and DSAM style modules). Use test instructions following, or those provided with tester. If SAM tests bad, replace it.
3. Reattach SAM leads, verifying a snug fit at ignition module terminals. If any connections do not feel snug, disconnect lead, lightly pinch female terminal with a pliers, and recheck fit.
4. Seal base of ignition module connections with GE/Novaguard G661 or equivalent dielectric compound. Beads should overlap between two connections to form a solid bridge of compound. Do not put any compound inside connectors.

24 584 15-S ignition modules have a separator/barrier between terminals. On these modules, seal base of terminal if any portion of it is exposed, but it is not necessary to have overlapping beads of sealant between connections.
5. Test for spark to be sure system is working, before you reinstall blower housing. If there is still a spark problem on one side, replace that ignition module and recheck spark.

Test ASAM and DSAM

Allow 15-20 seconds for tester to clear and reset itself between tests or if test is interrupted before completion of test cycle. Otherwise, a false reading may be displayed in form of a (–) or a faint 8.

Tester is powered by a 9-volt battery. Most SAMs are designed to operate down to a minimum of 7.25 volts. If tester battery drops below that level, incorrect test readings will result. Tester battery should be checked periodically by connecting a DC voltmeter between red and green lead wires, with tester connected to a SAM. Press and hold test button for a full test cycle (F or P appears and then display shuts off), while monitoring voltage reading on voltmeter. If voltage drops below 7.5 at any time during cycle, 9-volt tester battery must be replaced. Use an extended life (alkaline) battery.

To replace battery, remove outer set of screws on faceplate and carefully lift panel from body. Unplug connector and pull battery (with mounting tape) off back of tester. Attach connector to new battery and mount battery to case with double-backed tape. Reinstall faceplate and secure with four screws.

Electrical System

To test ASAM only using 25 761 21-S tester:

NOTE: SAM must be at room temperature when tested. Disconnect all SAM leads, isolating it from main wiring harness and ignition module(s). Testing may be performed with module mounted or loose.

NOTE: Do not allow alligator clip leads to touch each other.

1. Connect tester to SAM by attaching:
 - a. Yellow tester lead to long yellow module lead.
 - b. Brown tester lead to long brown module lead.
 - c. Red tester lead to red module lead.
 - d. Green tester lead to green module lead.
2. Check SAM part number stamped on side of housing. Verify that you have an analog SAM (ASAM) Part No. 24 584 10 or lower, not a digital SAM (DSAM) Part No. 24 584 18 and higher. Follow sub-step a for testing an ASAM with this tester. Digital SAM (DSAM) modules require Tester 25 761 40-S for proper testing.
 - a. Depress tester button and hold it down. After approximately four seconds, a numerical sequence should be displayed, beginning with 1 or 2 and continuing to 8 or 9, followed by a letter P (pass) or F (fail). Do not release tester button until test cycle completes and display goes off. If you get a (-) sign instead of numerical sequence, and/or an F at end of cycle, SAM is probably bad. Recheck all connections, check condition of tester battery and repeat test. If you get (-) sign and/or F again in retest, replace that SAM.
3. Disconnect yellow and brown tester leads from long module leads. Connect brown tester lead to short brown module lead. Connect yellow tester lead to short yellow (or pink) module lead. Leave red and green leads connected. Repeat step 2.

To test DSAM and ASAM using 25 761 40-S tester:

NOTE: Do not allow alligator clip leads to touch each other.

NOTE: SAM must be at room temperature when tested. Disconnect all SAM leads, isolating it from main wiring harness and ignition module(s). Testing may be performed with module mounted or loose.

NOTE: Some modules contain two black ground leads, with one containing a white stripe. Do not connect to black/white lead with bullet connector or a Fail test result will occur, regardless of actual condition.

Test procedure for twin cylinder SAMs will vary slightly, depending on whether module is analog (ASAM) or digital (DSAM).

1. Check SAM part number stamped on end of housing.
 - a. If it is an ASAM (24 584 09 or 24 584 10), separate short yellow and brown leads from long ones. Each set will be tested separately. Connect tester to SAM as follows:

- Yellow tester lead to long yellow module lead.
- Brown tester lead to long brown module lead.
- Red tester lead to red module lead.
- Black tester lead to black or green module lead.

Remaining tester leads (pink and brown with black band) are not used for testing ASAMs.

b. If it is a DSAM (all except 24 584 09 or 24 584 10), connect tester as follows:

- Yellow tester lead to long yellow module lead.
- Brown tester lead to long brown module lead.
- Red tester lead to red module lead.
- Black tester lead to green or black module ground lead with eyelet terminal.
- Pink tester lead to short yellow or pink module lead.
- Brown tester lead with black band or terminal to short brown module lead.

2. Recheck SAM part number, noting last two digits. Refer to table below or on tester faceplate to determine test number to be used.

SAM Part No.	12 584 12 24 584 09 24 584 10	24 584 30 24 584 31	24 584 33 24 584 34	24 584 32
Test No.	1	2	3	4

SAM Part No.	-	24 584 18 24 584 27	24 584 19	24 584 38 24 584 39
Test No.	5	6	7	8

3. Depress tester button repeatedly until correct test number appears on display. After a few seconds, test number will flash three times and test will begin. A reverse numerical sequence will be displayed, starting with a 6 and progressing down to 1, followed by a P (pass) or F (fail), indicating condition of part. If testing an ASAM, return to step 1 and move yellow and brown tester leads to short set of module leads, then repeat test.
4. If you get a (-) sign instead of numerical sequence, and/or an F at end of test cycle, recheck all of connections, check condition of tester battery and repeat test. If you get (-) or F sign again in retest replace SAM.

BATTERY CHARGING SYSTEM

NOTE: Observe following guidelines to avoid damage to electrical system and components:

- Make sure battery polarity is correct. A negative (-) ground system is used.
- Disconnect rectifier-regulator plug and/or wiring harness plug before doing any electric welding on equipment powered by engine. Disconnect all other electrical accessories in common ground with engine.
- Prevent stator (AC) leads from touching or shorting while engine is running. This could damage stator.

Most engines are equipped with a 15 or 20 amp regulated charging system. Some have a 25 amp regulated charging system. Some engines utilize a 3 amp unregulated system with optional 70 watt lighting circuit.

15/20/25 Amp Regulated Charging System

Stator

Stator is mounted on crankcase behind flywheel. Follow procedures in Disassembly and Reassembly if stator replacement is necessary.

Rectifier-Regulator

NOTE: When installing rectifier-regulator, take note of terminal markings and install plug(s) accordingly.

NOTE: Disconnect all electrical connections attached to rectifier-regulator. Testing may be performed with rectifier-regulator mounted or loose. Repeat applicable test procedure 2 or 3 times to determine condition of part.

Rectifier-regulator is mounted on blower housing. To replace it, disconnect plug(s), remove two mounting screws, and ground wire or metal grounding strap.

Testing of rectifier-regulator may be performed as follows, using appropriate Rectifier-Regulator Tester.

To test 4/15 amp rectifier-regulators:

1. Connect tester ground lead (with spring clamp) to body of rectifier-regulator being tested.
2. Connect tester red lead to B+ terminal of rectifier-regulator and 2 black tester leads to 2 AC terminals.
3. Plug tester into proper AC outlet/power for tester being used. Turn on power switch. POWER light should be illuminated and 1 of 4 status lights may be on as well. This does not represent condition of part.
4. 4 amp: Press TEST button until a click is heard and then release. Momentarily either HIGH, LOW, or SHORT light will flash.

15 amp: Press TEST button until a click is heard and then release. Momentarily 1 of 4 status lights will illuminate, indicating condition of part.

To test 20/25 amp rectifier-regulators:

1. 20 amp: Connect single lead adapter in between B+ (center) terminal of rectifier-regulator being tested and squared single end of tandem adapter lead.
25 amp: Connect squared single end of tandem lead adapter to B+ (center/red) lead of rectifier-regulator being tested.
2. Connect tester ground lead (with spring clamp) to body of rectifier-regulator.
3. Connect red lead and 1 of black leads to pair of terminals on open end of tandem adapter lead (connections are not location specific).
4. Connect remaining black lead from tester to 1 of outer AC terminals on rectifier-regulator.
5. Plug tester into proper AC outlet/power for tester being used. Turn on power switch. POWER light should be illuminated and 1 of 4 status lights may be on as well. This does not represent condition of part.
6. Press TEST button until a click is heard and then release. Momentarily 1 of 4 status lights will illuminate indicating partial condition of part.

Condition	Conclusion			
	4 amp	15 Amp	20 amp	25 amp
OK (green) or HIGH light comes on and stays steady.	Part is good and may be used.		Disconnect tester black lead attached to 1 AC terminal and reconnect it to other AC terminal. Repeat test. If OK (green) light comes on again, part is good and may be used.	
NOTE: A flashing LOW light can also occur as a result of an inadequate ground lead connection. Make certain connection location is clean and clamp is secure. Other lights come on.	Rectifier-regulator is faulty and should not be used.			

Electrical System

15/20/25 Amp Battery Charging Systems

NOTE: Always zero ohmmeter on each scale before testing to ensure accurate readings. Voltage tests should be made with engine running at 3600 RPM with no load. Battery must be good and fully charged.

When problems occur in keeping battery charged or battery charges at high rate, charging system or battery might be causing problems.

To test charging system for no charge to battery:

1. Insert an ammeter in B+ lead from rectifier-regulator. With engine running at 3600 RPM and B+ (at terminal on rectifier-regulator) to ground using a DC voltmeter.

If voltage is 13.8 volts or more, place a minimum load of 5 amps (turn on lights if 60 watts or more, or place a 2.5 ohm, 100 watt resistor across battery terminals) on battery to reduce voltage. Observe ammeter.

Condition	Conclusion
Charge rate increases when load is applied.	Charging system is OK and battery was fully charged.
Charge rate does not increase when load is applied.	Test stator and rectifier-regulator (steps 2 and 3).

2. Remove connector from rectifier-regulator. With engine running at 3600 RPM, measure AC voltage across stator leads using an AC voltmeter.

Condition	Conclusion
Voltage is 28 volts or more.	Stator is OK. Rectifier-regulator is faulty; replace.
Voltage is less than 28 volts.	Stator is faulty; replace. Test stator further using an ohmmeter (steps 3 and 4).

3. With engine stopped, measure resistance across stator leads using an ohmmeter.

Condition	Conclusion
Resistance is 0.1/0.2 ohms.	Stator is OK.
Resistance is 0 ohms.	Stator is shorted; replace.
Resistance is infinity ohms.	Stator is open; replace.

4. With engine stopped, measure resistance from each stator lead to ground using an ohmmeter.

Condition	Conclusion
Resistance is infinity ohms (no continuity).	Stator is OK (not shorted to ground).
Resistance (or continuity) measured.	Stator leads are shorted to ground; replace.

To test charging system for battery continuously charging at high rate:

1. With engine running at 3600 RPM, measure voltage from B+ lead to ground using a DC voltmeter.

Condition	Conclusion
Voltage is 14.7 volts or less.	Charging system is OK. Battery is unable to hold charge; service or replace.
Voltage is more than 14.7 volts.	Faulty rectifier-regulator; replace.

3 Amp/70 Watt Lighting Stator

NOTE: Always zero ohmmeter on each scale before testing to ensure accurate readings. Voltage tests should be made with engine running at 3600 RPM with no load. Battery must be good and fully charged.

To test charging system for no charge to battery:

1. With engine running in fast setting, measure voltage across battery terminals using a DC voltmeter.

Condition	Conclusion
Voltage is more than 12.5 volts.	Charging system is OK.
Voltage is 12.5 volts or less.	Stator or diode are probably faulty. Continue testing stator and diode.

2. Remove connector from rectifier-regulator. With engine running in fast position, measure AC voltage across stator leads using an AC voltmeter.

Condition	Conclusion
Voltage is 28 volts or more.	Stator winding is OK.
Voltage is less than 28 volts.	Test stator using an ohmmeter.

3. With charging lead disconnected from battery and engine stopped, measure resistance from charging lead to ground using an ohmmeter. Note reading. Reverse leads and measure resistance again.
In one direction, resistance should be infinity ohms (open circuit). With leads reversed, some resistance should be measured (about midscale on Rx1 range).

Condition	Conclusion
Resistance is low in both directions.	Diode is shorted. Replace diode.
Resistance is high in both directions.	Diode or stator winding is open. Continue testing.

4. Cut sleeving on charging lead to expose diode connections.

Measure resistance from stator side of diode to ground using an ohmmeter.

Condition	Conclusion
Resistance is approximately 1.07 ohms.	Stator winding is OK, diode is open. Replace diode.
Resistance is 0 ohms.	Stator winding is shorted. Replace stator.
Resistance is infinity ohms.	Stator winding or lead is open. Replace stator.

To test charging system for no lights:

1. Make sure lights are not burned out.

Condition	Conclusion
Burned out lights.	Replace.

2. Disconnect lighting lead from wiring harness. With engine running in fast setting, measure voltage from lighting lead to ground using an AC voltmeter.

Condition	Conclusion
Voltage is 15 volts or more.	Stator is OK. Check for loose connections or shorts in wiring harness.
Voltage is less than 15 volts.	Test stator using an ohmmeter.

3. With engine stopped, measure resistance of stator from lighting lead to ground using an ohmmeter.

Condition	Conclusion
Resistance is approximately 0.4 ohms.	Stator is OK.
Resistance is 0 ohms.	Stator is shorted. Replace stator.
Resistance is infinity ohms.	Stator or lighting lead is open. Replace stator.

Starter System

NOTE: Do not crank engine continuously for more than 10 seconds. Allow a 60 second cool down period between starting attempts. Failure to follow these guidelines can burn out starter motor.

NOTE: If engine develops sufficient speed to disengage starter but does not keep running (a false start), engine rotation must be allowed to come to a complete stop before attempting to restart engine. If starter is engaged while flywheel is rotating, starter pinion and flywheel ring gear may clash and damage starter.

NOTE: If starter does not crank engine, shut off starter immediately. Do not make further attempts to start engine until condition is corrected.

NOTE: Do not drop starter or strike starter frame. Doing so can damage starter.

Engines in this series use inertia drive or solenoid shift starters.

Troubleshooting-Starting Difficulties

Condition	Possible Cause	Conclusion
Starter does not energize.	Battery	Check specific gravity of battery. If low, recharge or replace battery as necessary.
	Wiring	Clean corroded connections and tighten loose connections. Replace wires in poor condition and with frayed or broken insulation.
	Starter Switch or Solenoid	By-pass switch or solenoid with a jumper wire. If starter cranks normally, replace faulty components. Remove and perform individual solenoid test procedure.
Starter energizes but turns slowly.	Battery	Check specific gravity of battery. If low, recharge or replace battery as necessary.
	Brushes	Check for excessively dirty or worn brushes and commutator. Clean using a coarse cloth (not emery cloth). Replace brushes if excessively or unevenly worn.
	Transmission or Engine	Make sure clutch or transmission is disengaged or placed in neutral. This is especially important on equipment with hydrostatic drive. Transmission must be exactly in neutral to prevent resistance which could keep engine from starting. Check for seized engine components such as bearings, connecting rod, and piston.

INERTIA DRIVE ELECTRIC STARTERS

Inertia Drive Starter Components

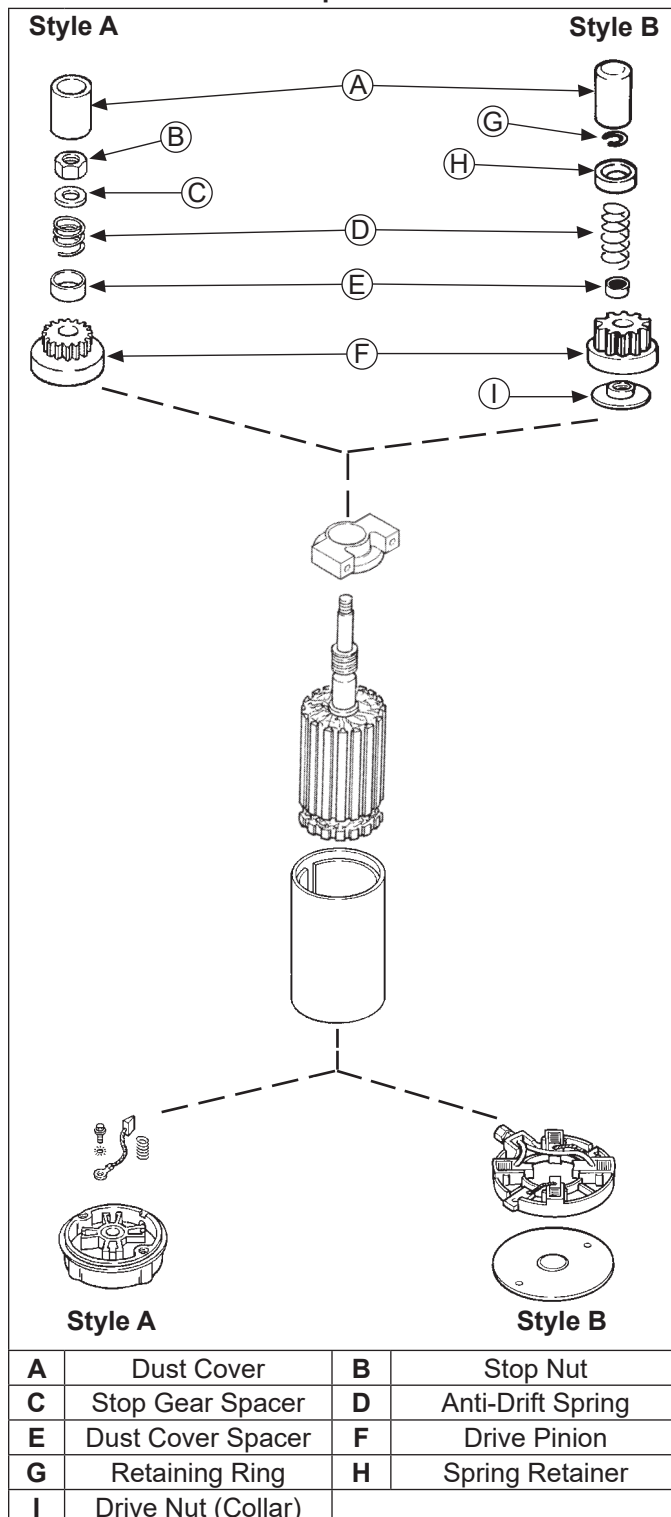

When power is applied to starter, armature rotates. As armature rotates, drive pinion moves out on drive shaft splines and into mesh with flywheel ring gear. When pinion reaches end of drive shaft, it rotates flywheel and cranks engine.

When engine starts, flywheel rotates faster than starter armature and drive pinion. This moves drive pinion out of mesh with ring gear and into retracted position. When power is removed from starter, armature stops rotating and drive pinion is held in retracted position by anti-drift spring.

Starter Drive Service

Style A

NOTE: Do not over-tighten vise as this can distort drive pinion.

1. Remove starter from engine and remove dust cover.
2. Hold drive pinion in a vise with soft jaws when removing or installing stop nut. Armature will rotate with nut until drive pinion stops against internal spacers.
3. Remove stop nut, stop gear spacer, anti-drift spring, dust cover spacer, and drive pinion.
4. Clean splines on drive shaft thoroughly with solvent. Dry splines thoroughly.
5. Apply a small amount of Rehlko electric starter drive lubricant, to splines. Use of other lubricants may cause drive pinion to stick or bind.
6. Apply a small amount of Loctite® 271™ to stop nut threads.
7. Install drive pinion, dust cover spacer, anti-drift spring, stop gear spacer, and stop nut. Torque stop nut to 17.0-19.2 N·m (150-170 in. lb.). Reinstall dust cover.

Style B

1. Rubber dust cover has a molded lip on inside that snaps into a groove in dust cover spacer. Turn drive pinion clockwise until it reaches fully extended position. While holding it in extended position, grasp tip of dust cover with a pliers or vise grip and pull it free from spacer.
2. Disassemble snap ring removal tool.
3. Grasp spring retainer and push it toward starter, compressing anti-drift spring and exposing retaining ring.
4. Holding spring retainer in retracted position, assemble inner halves of removal tool around armature shaft with retaining ring in inner groove. Slide collar over inner halves to hold them in position.
5. Thread center screw into removal tool until you feel resistance. Use a wrench (1-1/8 or adjustable) to hold base of removal tool. Use another wrench or socket (1/2 in. or 13 mm) to turn center screw clockwise. Resistance against center screw will tell you when retaining ring has popped out of groove in armature shaft.
6. Remove drive components from armature shaft, paying attention to sequence. If splines are dirty, clean them with solvent.
7. Splines should have a light film of lubricant. Relubricate as necessary with Rehlko starter drive lubricant. Reinstall or replace drive components, assembling them in reverse order they were removed.

Starter System

Retaining Ring Installation

1. Position retaining ring in groove in one of inner halves. Assemble other half over top and slide on outer collar.
2. Be certain drive components are installed in correct sequence onto armature shaft.
3. Slip tool over end of armature shaft, so retaining ring inside is resting on end of shaft. Hold tool with one hand, exerting slight pressure toward starter. Tap top of tool with a hammer until you feel retaining ring snap into groove. Disassemble and remove tool.
4. Squeeze retaining ring with a pliers to compress it into groove.
5. Assemble inner halves with larger cavity around spring retainer. Slide collar over them and thread center screw in until resistance is felt.
6. Hold base of tool with a 1-1/8 wrench and turn center screw clockwise with a 1/2 or 13 mm wrench to draw spring retainer up around retaining ring. Stop turning when resistance increases. Disassemble and remove tool.
7. Reinstall dust cover.

Starter Disassembly

1. Remove drive components following instructions for servicing drive.
2. Locate small raised line on edge of drive end cap. On starters with style A commutator end caps, it will be aligned with a pre-marked line on starter frame. Frame is not pre-marked on starters with style B end caps. Place a piece of masking tape on frame and mark a line on tape in line with raised line on end cap.
3. Remove thru bolts.
4. Remove commutator end cap with brushes and brush springs (style A). Style B end caps remove as a separate piece with brushes and carrier remaining in frame.
5. Remove drive end cap.
6. Remove armature and thrust washer (if equipped) from inside starter frame.
7. Remove brush/carrier assembly from frame (style B starters).

Brush Replacement

Style A

NOTE: Use a brush holder tool to keep brushes in pockets. A brush holder tool can easily be made from thin sheet metal.

1. Remove brush springs from pockets in brush holder.
2. Remove self-tapping screws, negative (-) brushes, and plastic brush holder.
3. Remove nut and fiber washer from stud terminal.
Remove stud terminal with positive (+) brushes and plastic insulating bushing from end cap.

4. Install insulating bushing on stud terminal of new positive (+) brushes. Install stud terminal into commutator end cap. Secure stud with fiber washer and screw.
5. Install brush holder, new negative (-) brushes, and self-tapping screws.
6. Install brush springs and brushes into pockets in brush holder. Make sure chamfered sides of brushes are away from brush springs.

Style B

Starters with style B end caps have brushes in a plastic carrier housing, separate from end cap. Replacement brushes come preassembled in carrier housing, retained with two carton staples.

Commutator Service

Clean commutator with a coarse, lint free cloth. Do not use emery cloth.

If commutator is badly worn or grooved, turn it down on a lathe or replace starter.

Starter Reassembly

1. Place thrust washer (if equipped) over drive shaft of armature.
2. Insert armature into starter frame. Make sure magnets are closer to drive shaft end of armature. Magnets will hold armature inside frame.
3. Install drive end cap over drive shaft. Make sure match marks on end cap and starter frame are aligned.
4. Style A commutator end caps:
Install brush holder tool to keep brushes in pockets of commutator end cap.
Align match marks on commutator end cap and starter frame. Hold drive end and commutator end caps firmly to starter frame. Remove brush holder tool.
Style B commutator end caps:
If brush assembly is not being replaced, position brushes in their pockets in carrier. Move them to retracted position, and install carton staples to retain them.
Align terminal stud block with notch in starter frame and slide brush/carrier assembly into frame. Commutator will push carton staples out as brush assembly is installed. Position end cap over brush assembly, so holes for thru bolts are aligned with those in brush carrier.
5. Install thru bolts and tighten securely.
6. Lubricate drive shaft with Rehlko starter drive lubricant. Install drive components following instructions for servicing starter drive.

SOLENOID SHIFT ELECTRIC STARTERS

Solenoid Shift Starter Components

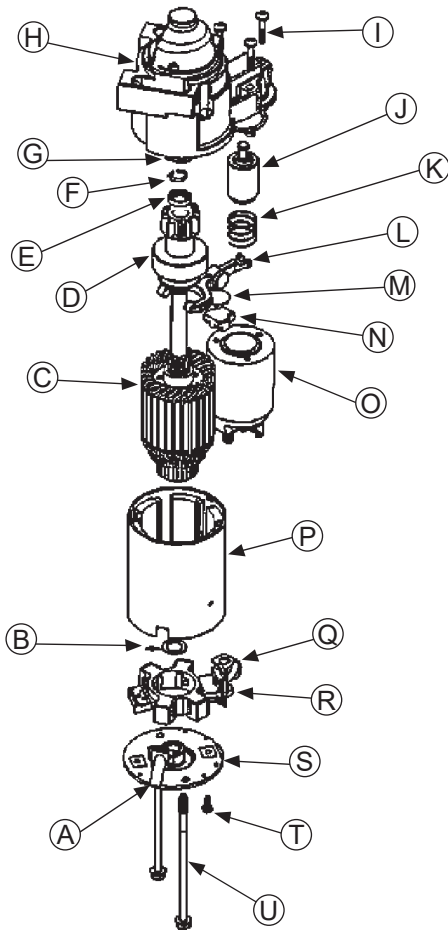

A	Tube	B	Washer
C	Armature	D	Drive
E	Stop	F	Retaining Ring
G	Collar	H	Drive End Cap
I	Screw	J	Plunger
K	Spring	L	Lever
M	Plate	N	Plug
O	Solenoid	P	Frame and Field
Q	Brush Holder	R	Nut
S	Commutator End Plate	T	Screw
U	Bolt		

When power is applied to starter electric solenoid moves drive pinion out onto drive shaft and into mesh with flywheel ring gear. When pinion reaches end of drive shaft it rotates flywheel and cranks engine.

When engine starts and start switch is released, starter solenoid is deactivated, drive lever moves back, and drive pinion moves out of mesh with ring gear into retracted position.

Nippondenso Starters

Starter Disassembly

NOTE: When removing lever and armature be careful not to lose thrust washer.

1. Disconnect lead wire from solenoid.
2. Remove nuts securing solenoid, and remove solenoid from starter assembly.
3. Remove thru bolts.
4. Remove commutator end cap.
5. Remove insulator and brush springs from brush spring holder.
6. Remove armature from frame.
7. Remove drive lever and armature from drive end cap.
8. Stop collar consists of two similar pieces held in place by being snapped over a retainer. Retainer is held in place by a groove in armature shaft. To remove stop collar two pieces must be pried off retainer.
9. When stop collars are removed retainer can be removed from armature shaft. Do not reuse retainer.

Brush Replacement

Brushes in starter are part of starter frame. Brush kit contains four replacement brushes and springs. If replacement is necessary, all four brushes should be replaced.

1. Remove brushes from brush holder, and remove brush holder from frame.
2. Cut brush lead wire at edge of post with a pair of nippers.
3. File off any burrs on post.
4. Replacement brushes have a solid portion which should be crimped on post.
5. Solder crimped portion to post.
6. Replace brush holder in frame and place brushes in brush holder. Reinstall springs.

Starter Reassembly

NOTE: Always use a new retainer. Tighten retainer in groove to secure.

1. Insert rear stop collar on armature shaft.
2. Place retainer in groove on armature shaft.
3. Fit front stop collar over shaft and bring front and rear stop collars together over retainer. Using two pairs of pliers apply even force to two collars until they snap over retainer and nest into one another.
4. Reassemble remaining components of starter in reverse order from disassembly.

Delco-Remy Starters

Starter Disassembly

NOTE: Do not reuse old retainer.

NOTE: Do not soak armature or use solvent when cleaning. Wipe clean using a soft cloth, or use compressed air.

1. Remove hex nut and disconnect positive (+) brush lead/bracket from solenoid terminal.

Starter System

2. Remove head screws securing solenoid to starter.
3. If solenoid was mounted with Phillips head screws, separate solenoid and plunger spring from drive end cap. If solenoid was mounted with external Torx head screws, plunger is part of solenoid, unhook plunger pin from drive lever. Remove gasket from recess in housing.
4. Remove thru (larger) bolts.
5. Remove commutator end plate assembly, containing brush holder, brushes, springs, and locking caps. Remove thrust washer from inside commutator end.
6. Remove frame from armature and drive end cap.
7. Remove drive lever pivot bushing and backing plate from end cap.
8. Take out drive lever and pull armature out of drive end cap.
9. Remove thrust washer from armature shaft.
10. Push stop collar down to expose retaining ring.
11. Remove retainer from armature shaft. Save stop collar.
12. Remove drive pinion assembly from armature.
13. Clean parts as required.

Inspection

Drive Pinion

Check and inspect following areas:

- Pinion teeth for abnormal wear or damage.
- Surface between pinion and clutch mechanism for nicks or irregularities which could cause seal damage.
- Check drive clutch by holding clutch housing and rotating pinion. Pinion should rotate in only 1 direction.

Brushes and Springs

Detail

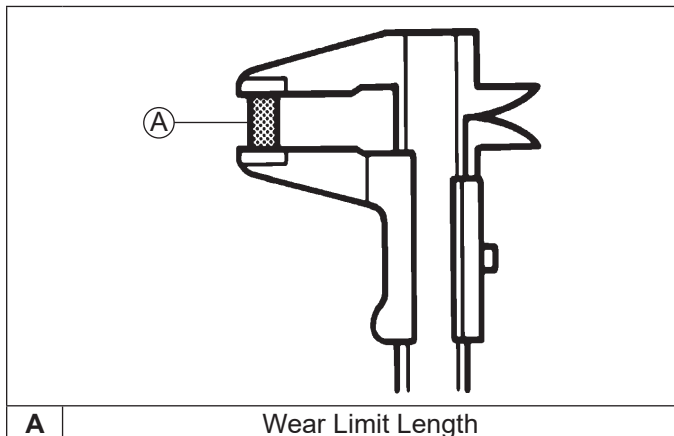

Inspect both springs and brushes for wear, fatigue, or damage. Measure length of each brush. Minimum length for each brush is 7.6 mm (0.300 in.). Replace brushes if they are worn, undersize, or condition is questionable.

Armature Components and Details

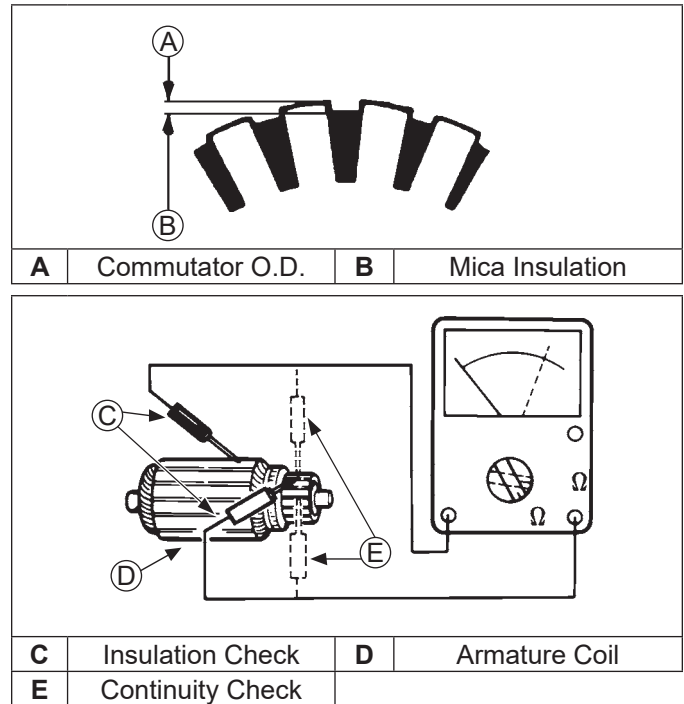

1. Clean and inspect commutator (outer surface). Mica insulation must be lower than commutator bars (undercut) to ensure proper operation of commutator.
2. Use an ohmmeter set to Rx1 scale. Touch probes between 2 different segments of commutator, and check for continuity. Test all segments. Continuity must exist between all or armature is bad.
3. Check for continuity between armature coil segments and commutator segments. There should be no continuity. If continuity exists between any 2 armature is bad.
4. Check armature windings/insulation for shorting.

Shift Fork

Check that shift fork is complete, and pivot and contact areas are not excessively worn, cracked, or broken.

Brush Replacement

4 brushes and springs are serviced as a set. Use a new Rehlko brush and spring kit if replacement is necessary.

1. Perform steps 1-5 in Starter Disassembly.
2. Remove screws securing brush holder assembly to end cap (plate). Note orientation for reassembly later. Discard old brush holder assembly.
3. Clean component parts as required.
4. New brushes and springs come preassembled in a brush holder with a protective sleeve that will also serve as an installation tool.
5. Perform Steps 10-13 in Starter Reassembly sequence. Installation must be done after armature, drive lever, and frame are installed, if starter has been disassembled.

Starter Reassembly

NOTE: Always use a new retainer. Do not reuse old retainers that have been removed.

NOTE: Correctly installed, center pivot section of drive lever will be flush or below machined surface of housing.

1. Apply drive lubricant to armature shaft splines. Install drive pinion onto armature shaft.
2. Install and assemble stop collar/retainer assembly.
 - a. Install stop collar down onto armature shaft with counter bore (recess) up.
 - b. Install a new retainer in larger (rear) groove of armature shaft. Squeeze with a pliers to compress it in groove.
 - c. Slide stop collar up and lock it into place, so recess surrounds retainer in groove. If necessary, rotate pinion outward on armature splines against retainer to help seat collar around retainer.
3. Install offset thrust (stop) washer so smaller offset of washer faces retainer/collar.
4. Apply a small amount of oil to bearing in drive end cap, and install armature with drive pinion.
5. Lubricate fork end and center pivot of drive lever with drive lubricant. Position fork end into space between captured washer and rear of pinion.
6. Slide armature into drive end cap and at same time seat drive lever into housing.
7. Install backup washer, followed by rubber grommet, into matching recess of drive end cap. Molded recesses in grommet should be out, matching and aligned with those in end cap.
8. Install frame, with small notch forward, onto armature and drive end cap. Align notch with corresponding section in rubber grommet. Install drain tube in rear cutout, if it was removed previously.
9. Install flat thrust washer onto commutator end of armature shaft.
10. Starter reassembly when replacing brushes/brush holder assembly:
 - a. Hold starter assembly vertically on end housing, and carefully position assembled brush holder assembly, with supplied protective tube, against end of commutator/armature. Mounting screw holes in metal clips must be up/out. Slide brush holder assembly down into place around commutator, and install positive (+) brush lead grommet in cutout of frame. Protective tube may be saved and used for future servicing.

Starter reassembly when not replacing brushes/brush holder assembly:

 - a. Carefully unhook retaining caps from brush assemblies. Do not lose springs.
 - b. Position brushes back in their slots so they are flush with I.D. of brush holder assembly. Insert brush installation tool (with extension), or use tube described above from a prior brush installation, through brush holder assembly, so holes in metal mounting clips are up/out.
 - c. Install brush springs and snap on retainer caps.
 - d. Hold starter assembly vertically on end housing, and carefully place tool (with extension) and assembled original brush holder assembly onto end of armature shaft. Slide brush holder assembly down into place around commutator, install positive (+) brush lead grommet in cutout of frame.
11. Install end cap onto armature and frame, aligning thin raised rib in end cap with corresponding slot in grommet of positive (+) brush lead.
12. Install thru bolts and brush holder mounting screws. Torque bolts to 5.6-9.0 N·m (49-79 in. lb.) and brush holder mounting screws to 2.5-3.3 N·m (22-29 in. lb.).
13. Hook plunger behind upper end of drive lever and install spring into solenoid. Insert mounting screws through holes in drive end cap. Use these to hold solenoid gasket in position, then mount solenoid. Torque screws to 4.0-6.0 N·m (35-53 in. lb.).
14. Connect positive (+) brush lead/bracket to solenoid and secure with nut. Torque nut to 8-11 N·m (71-97 in. lb.). Do not overtighten.

Starter System

Solenoid Tests

NOTE: DO NOT leave 12 volt test leads connected to solenoid for any time over what is necessary for performing each of individual tests. Internal damage to solenoid may occur.

Disconnect all leads from solenoid including positive brush lead attached to lower stud terminal. Remove mounting hardware and separate solenoid from starter for testing.

To test solenoid pull-in coil/plunger:

Actuation

1. Use a 12 volt power supply and 2 test leads.
2. Connect 1 lead to flat spade S/start terminal on solenoid. Momentarily connect other lead to lower large post terminal.
When connection is made solenoid should energize (audible click) and plunger retract. Repeat test several times.

Continuity

1. Use an ohmmeter set to audible or Rx2K scale, and connect 2 ohmmeter leads to 2 large post terminals.
2. Perform solenoid pull-in coil/plunger actuation test and check for continuity. Ohmmeter should indicate continuity. Repeat test several times.

To test solenoid hold-in coil:

Function

1. Connect a 12 volt test lead to flat spade S/start terminal on solenoid and other lead to body or mounting surface of solenoid.
2. Manually push plunger IN and check if coil holds plunger retracted. Do not allow test leads to remain connected to solenoid for a prolonged period of time.

Continuity

1. Use an ohmmeter set to audible or Rx2K scale, and connect 2 ohmmeter leads to 2 large post terminals.
2. Perform preceding solenoid hold-in coil function test and check for continuity. Meter should indicate continuity. Repeat test several times.

Condition	Conclusion
Solenoid fails to activate.	Replace solenoid.
No continuity is indicated.	
Plunger fails to stay retracted.	

Disassembly/Inspection and Service

	⚠ WARNING	Before working on engine or equipment, disable engine as follows: 1) Disconnect spark plug lead(s). 2) Disconnect negative (-) battery cable from battery.
	<p>Accidental Starts can cause severe injury or death.</p> <p>Disconnect and ground spark plug lead(s) before servicing.</p>	<p>Before disconnecting negative (-) ground cable, make sure all switches are OFF. If ON, a spark will occur at ground cable terminal which could cause an explosion if hydrogen gas or LPG/NG fuel vapors are present.</p>

External Engine Components

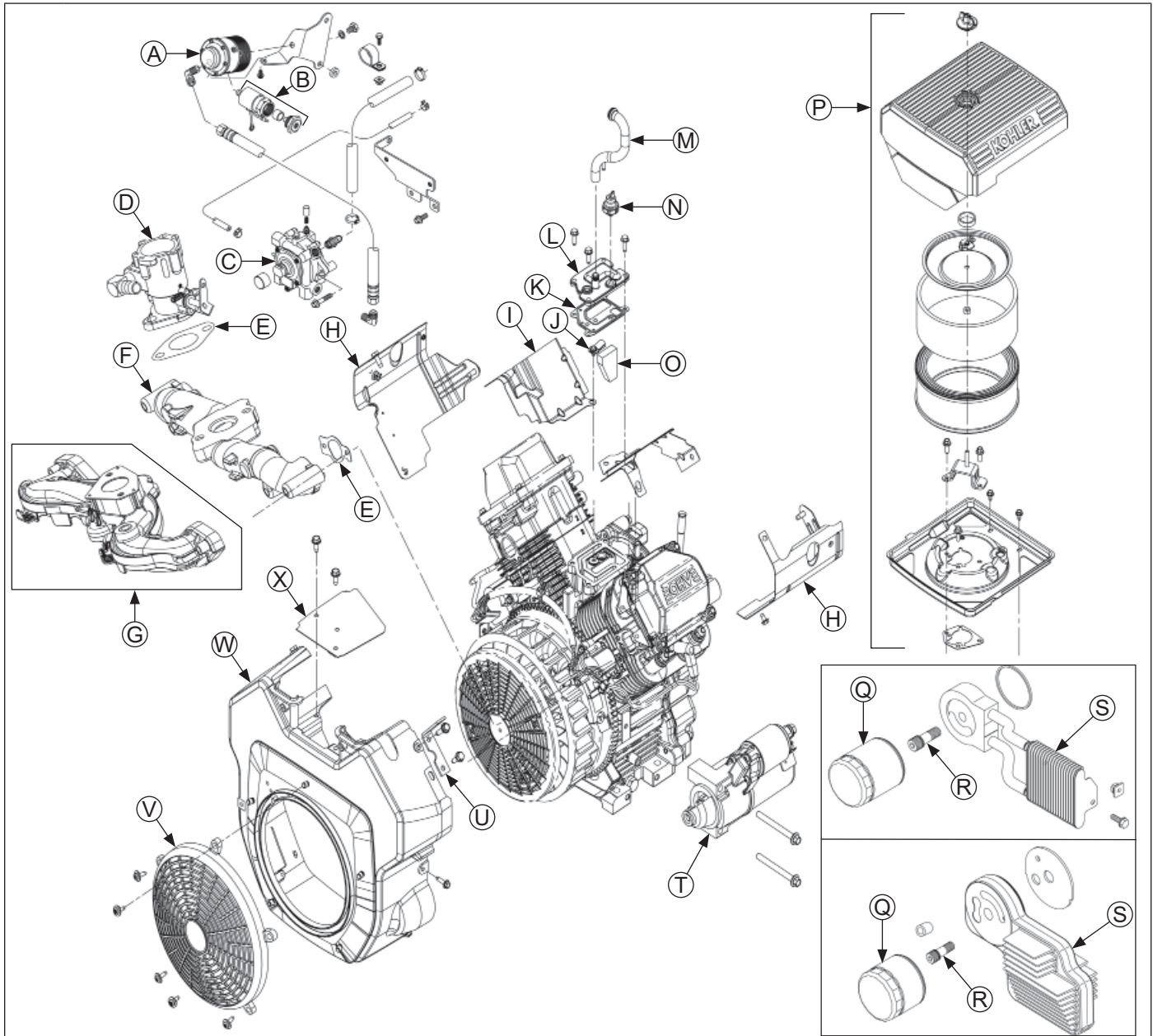

A	Vaporizer	B	Lock-off/Filter	C	Regulator	D	Carburetor
E	Gasket	F	Intake Manifold	G	Plastic Intake Manifold	H	Outer Baffle
I	Inner Baffle	J	Breather Reed	K	Breather Gasket	L	Breather Cover
M	Breather Tube	N	Oil Sentry™	O	Filter	P	Air Cleaner
Q	Oil Filter	R	Nipple	S	Oil Cooler	T	Electric Starter
U	Lifting Bracket	V	Fixed Guard	W	Blower Housing	X	Debris Shield

Disassembly/Inspection and Service

Clean all parts thoroughly as engine is disassembled. Only clean parts can be accurately inspected and gauged for wear or damage. There are many commercially available cleaners that will quickly remove grease, oil, and grime from engine parts. When such a cleaner is used, follow manufacturer's instructions and safety precautions carefully.

Make sure all traces of cleaner are removed before engine is reassembled and placed into operation. Even small amounts of these cleaners can quickly break down lubricating properties of engine oil.

Disconnect Spark Plug Leads

NOTE: Pull on boot only, to prevent damage to spark plug lead.

1. Disconnect leads from spark plugs.
2. Shut off fuel supply.

Drain Oil from Crankcase and Remove Oil Filter

1. Remove oil fill cap, dipstick, and 1 oil drain plug.
2. Allow ample time for oil to drain from crankcase and oil filter.
3. Remove and discard oil filter.
4. An oil cooler is standard equipment on some models and an option on others. It may be a cast aluminum housing, part of oil filter adapter, or attached to blower housing, separated from oil filter adapter. If equipped, remove adapter and cooler.

Remove Muffler

Remove exhaust system and attaching hardware from engine. On engines equipped with a port liner, remove it now.

Remove Air Cleaner Assembly

1. Unhook latches or loosen knob and remove cover.
2. Remove wing nut from element cover.
3. Remove element cover, air cleaner element with precleaner and stud seal.
4. Remove screws securing bracket and base. Additional rear screws must be removed if engine contains a rear air cleaner support bracket.
5. Remove bracket then remove base and gasket while carefully pulling rubber breather tube through base.
6. Remove rubber breather tube from breather cover.

Remove LPG/NG Components

	WARNING
	Explosive Fuel can cause fires and severe burns. If a gaseous odor is detected, ventilate area and contact an authorized service technician.
LPG is extremely flammable and is heavier than air and tends to settle in low areas where a spark or flame could ignite gas. Do not start or operate this engine in a poorly ventilated area where leaking gas could accumulate and endanger safety of persons in area.	
NG is extremely flammable, is lighter than air, and rises. Do not start or operate this engine in a poorly ventilated area where leaking gas could accumulate and endanger safety of persons in area.	
To ensure personal safety, installation and repair of LPG/NG fuel supply systems must be performed only by qualified LPG/NG system technicians. Improperly installed and maintained LPG/NG equipment could cause fuel supply system or other components to malfunction, causing gas leaks.	
Observe federal, state and local laws governing LPG/NG fuel, storage, and systems.	

1. Remove fuel lines and vacuum line from regulator. Remove screws securing regulator and bracket.
2. For LPG engines, remove fuel lines from vaporizer and lock-off/filter. Remove lock-off/filter from vaporizer. Remove screws securing vaporizer and bracket.

Remove Control Panel (if equipped)

1. Disconnect Oil Sentry™ indicator light wires.
2. Disconnect choke control cable from control bracket.
3. Disconnect throttle control cable or shaft.
4. Remove panel from blower housing.

Remove Throttle and Choke Controls (Mechanical Governor)

Control Bracket Components (Mechanical Governor)

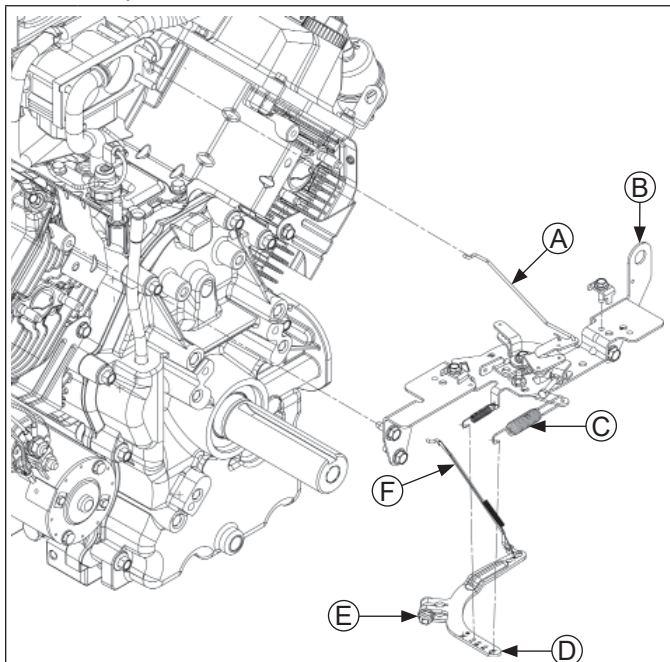

A	Choke Linkage	B	Control Bracket
C	Spring	D	Governor Lever
E	Nut	F	Throttle Linkage

1. Remove screws securing control bracket and rear air cleaner bracket (some models) to cylinder heads.
2. Mark spring hole locations and disconnect spring from governor lever.
3. Remove choke linkage from choke actuator lever and carburetor.

Remove External Governor Controls (Mechanical Governor)

Loosen nut and remove governor lever from cross shaft. Leave lever attached to throttle linkage and lay assembly on top of crankcase.

Remove Carburetor (Mechanical Governor)



⚠ WARNING

Explosive Fuel can cause fires and severe burns.

If a gaseous odor is detected, ventilate area and contact an authorized service technician.

LPG is extremely flammable and is heavier than air and tends to settle in low areas where a spark or flame could ignite gas. Do not start or operate this engine in a poorly ventilated area where leaking gas could accumulate and endanger safety of persons in area.

NG is extremely flammable, is lighter than air, and rises. Do not start or operate this engine in a poorly ventilated area where leaking gas could accumulate and endanger safety of persons in area.

To ensure personal safety, installation and repair of LPG/NG fuel supply systems must be performed only by qualified LPG/NG system technicians. Improperly installed and maintained LPG/NG equipment could cause fuel supply system or other components to malfunction, causing gas leaks.

Observe federal, state and local laws governing LPG/NG fuel, storage, and systems.

1. Disconnect ground lead, if equipped.
2. Remove carburetor mounting screws or nuts.
3. Remove carburetor, throttle linkage and governor lever as an assembly.
4. Remove carburetor gasket.
5. If necessary, carburetor, throttle linkage and governor lever can be separated. Reattach bushings to linkage following separation to avoid losing them.

Disassembly/Inspection and Service

Remove Carburetor and Electronic Governor Assembly

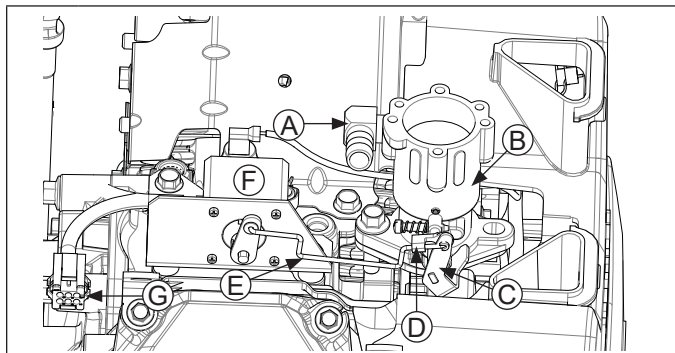

A	Carburetor Fitting	B	Carburetor
C	Carburetor Throttle Lever	D	Bushing
E	Throttle Linkage	F	Electronic Governor Assembly
G	Electronic Governor Connector		

1. Loosen hose clamp and remove fuel hose from carburetor fitting.
2. Remove screws securing carburetor to intake manifold.
3. Disconnect bushing securing throttle linkage to carburetor throttle lever. Lift carburetor off intake manifold and discard carburetor gasket.
4. Disconnect electronic governor connector from wiring harness.
5. Remove screws securing electronic governor assembly to crankcase; remove electronic governor assembly with throttle linkage.

Remove Oil Sentry™ (if equipped)

1. Disconnect lead from Oil Sentry™ switch.
2. Remove Oil Sentry™ switch from breather cover.

Remove Electric Starter Motor

1. Disconnect leads from starter.
2. Remove screws.
3. Remove starter assembly and any spacers (if used).

Remove Outer Baffles and Blower Housing

1. Disconnect plug from rectifier-regulator on blower housing.
2. Use tip of dipstick or a similar small flat tool to bend locking tang, then remove B+ (center lead) from terminal plug. This will allow blower housing to be removed without disturbing wiring harness.
3. Rectifier-regulator does not have to be detached from blower housing. If engine is equipped with SMART-SPARK™ SAM module should be removed from cylinder baffle or blower housing. Module will hang loose as part of wiring harness.
4. Remove screws securing outer baffles. Note location of any lifting strap and position of two short screws (one each side on bottom) for reassembly.
5. Remove outer baffles on both sides.
6. On engines equipped with a metal debris screen, remove screen before removing blower housing. Plastic debris screens can be removed after blower housing is removed.
7. Remove lower blower housing screw and washer securing rectifier-regulator ground lead or grounding strap.
8. Remove remaining screws and detach blower housing.
9. Disconnect plug from key switch in blower housing if engine is equipped.

Remove Inner Baffles and Breather Cover

Inner (valley) baffles are attached at one corner using same fasteners as breather cover.

1. Remove screws securing inner baffles.
2. Remove both inner baffles.
3. Remove two remaining screws holding breather cover to crankcase.
4. Pry under protruding edge of breather cover with a screwdriver to break RTV or gasket seal. Do not pry on sealing surfaces as it could cause damage resulting in leaks. Most engines use a formed gasket rather than RTV sealant.
5. Remove breather cover and gasket (if used).
6. Remove breather filter from chamber.
7. Remove screw, breather reed retainer and breather reed.

Remove Intake Manifold

1. Remove screws securing intake manifold to cylinder heads. Note which screws hold wiring clamps.
2. Remove intake manifold and intake manifold gaskets (aluminum intake manifolds) or O-rings (plastic intake manifolds).
3. Leave wiring harness attached to manifold.

Cylinder Head Components

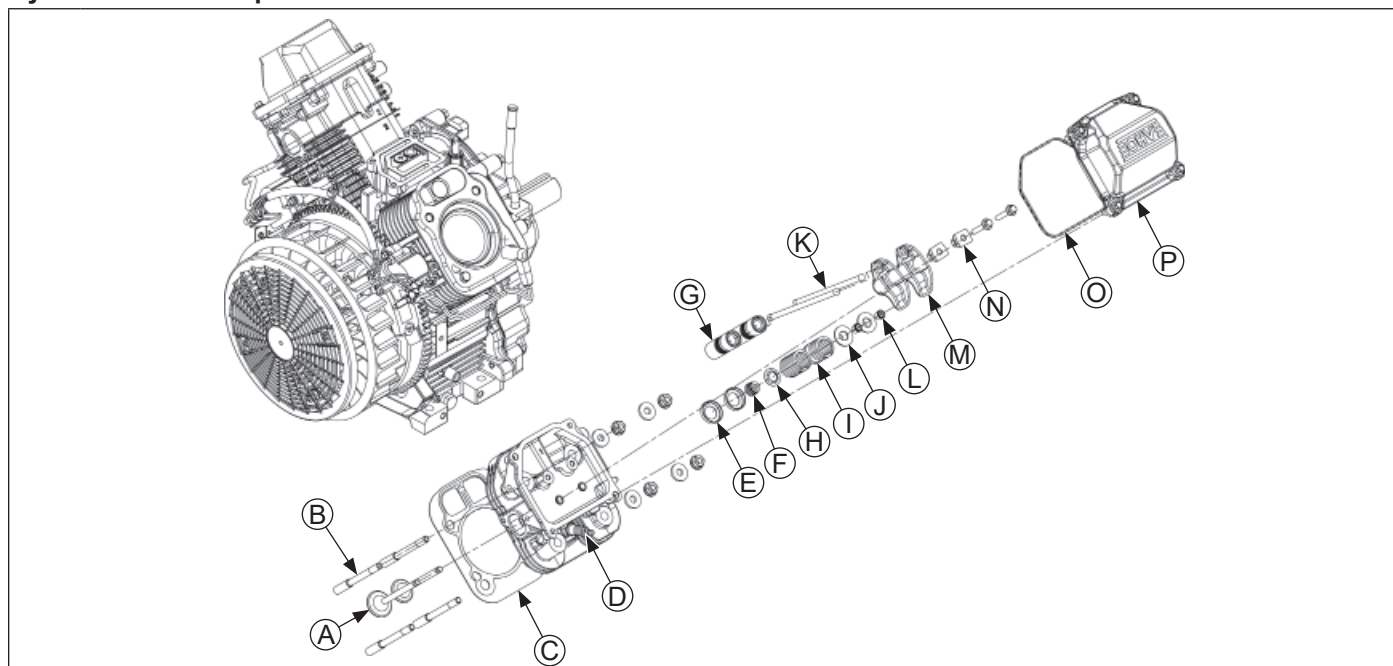

A	Valve	B	Stud	C	Gasket	D	Spark Plug
E	Cap	F	Valve Stem Seal	G	Hydraulic Lifter	H	Retainer
I	Valve Spring	J	Valve Spring Retainer	K	Push Rod	L	Valve Keeper
M	Rocker Arm	N	Rocker Arm Pivot	O	Valve Cover O-ring	P	Valve Cover

Remove Valve Covers

Three valve cover designs have been used. Earliest type used a gasket and RTV sealant between cover and sealing surface of cylinder head. Second type had a black O-ring installed in a groove on underside of cover and may have metal spacers in bolt holes. Latest design uses a brown O-ring, and bolt holes spacers are molded in place.

1. Remove screws securing each valve cover. Note position of any attached brackets or lifting straps.
2. Remove valve covers, valve cover gaskets or O-rings and any brackets or lifting straps. Note which side of engine has oil fill valve cover.

Remove Spark Plugs

Remove spark plug from each cylinder head.

Remove Cylinder Heads and Hydraulic Lifters

NOTE: Cylinder heads are retained using either screws or nuts and washers on studs. Do not interchange or mix components, as cylinder heads may have different machining, unique to each fastening method.

NOTE: Exhaust lifters are located on output shaft side of engine while intake lifters are located on fan side of engine. Cylinder head number is embossed on outside of each cylinder head.

1. Remove screws or nuts and washers securing each cylinder head. Unless screws are damaged or questionable, they can be reused. Discard nuts and washers once removed; do not reuse. Studs (if present) should only be removed if damaged or if cylinder reconditioning is necessary. Once removed, they must be replaced.
2. Mark position of push rods as either intake or exhaust and cylinder 1 or 2. Push rods should always be reinstalled in same positions.
3. Carefully remove push rods, cylinder heads and head gaskets.
4. Remove lifters from lifter bores. Use a Hydraulic Lifter Tool. Do not use a magnet to remove lifters. Mark lifters by location, as either intake or exhaust and cylinder 1 or 2. Hydraulic lifters should always be reinstalled in same position.

Disassembly/Inspection and Service

Disassemble Cylinder Heads

NOTE: These engines use valve stem seals on intake valves. Use a new seal whenever valve is removed or if seal is deteriorated in any way. Never reuse an old seal.

1. Remove screws, rocker arm pivots and rocker arms from cylinder head. Note screw color for reassembly.
2. Compress valve springs using a valve spring compressor.
3. Once valve spring is compressed, remove following items.
 - Valve spring keepers.
 - Valve spring retainers.
 - Valve springs.
 - Valve spring caps.
 - Intake and exhaust valves (mark position).
 - Valve stem seals (intake valve only).
4. Repeat above procedure for other cylinder head. Do not interchange parts from one cylinder head to other.

Inspection and Service

Valve Details

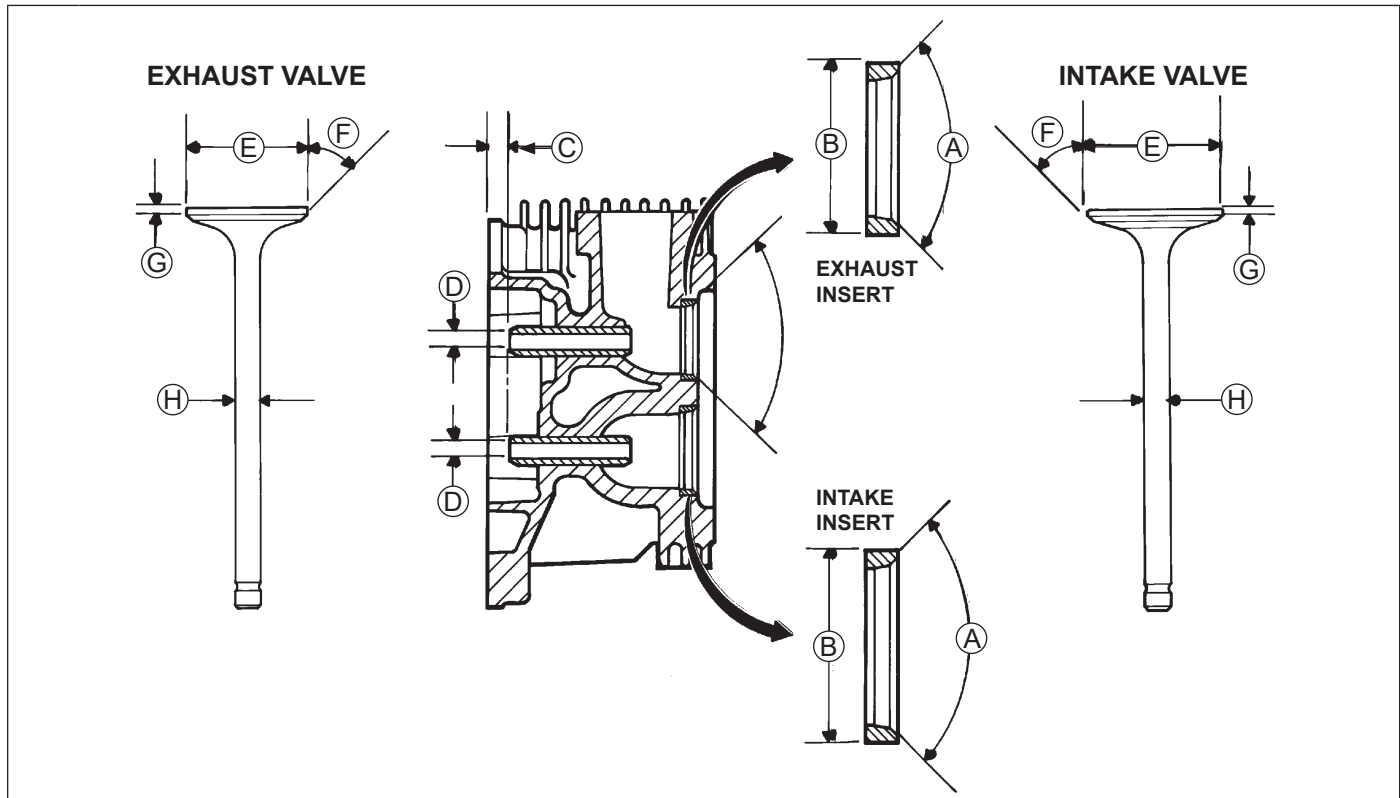

Dimension		Intake	Exhaust
A	Seat Angle	89°	89°
B	Insert O.D.	36.987/37.013 mm (1.4562/1.4572 in.)	32.987/33.013 mm (1.2987/1.2997 in.)
C	Guide Depth	4 mm (0.1575 in.)	6.5 mm (0.2559 in.)
D	Guide I.D.	7.038/7.058 mm (0.2771/0.2779 in.)	7.038/7.058 mm (0.2771/0.2779 in.)
E	Valve Head Diameter	33.37/33.63 mm (1.3138/1.3240 in.)	29.37/29.63 mm (1.1563/1.1665 in.)
F	Valve Face Angle	45°	45°
G	Valve Margin (Min.)	1.5 mm (0.0591 in.)	1.5 mm (0.0591 in.)
H	Valve Stem Diameter	6.982/7.000 mm (0.2749/0.2756 in.)	6.970/6.988 mm (0.2744/0.2751 in.)

After cleaning, check flatness of cylinder head and corresponding top surface of crankcase, using a surface plate or precision straight edge and feeler gauge. For all except 83 mm bore maximum allowable out of flatness is 0.076 mm (0.003 in.). For 83 mm bore maximum allowable out of flatness is 0.1 mm (0.004 in.).

Carefully inspect valve mechanism parts. Inspect valve springs and related hardware for excessive wear or distortion. Check valves and valve seat area or inserts for evidence of deep pitting, cracks, or distortion. Check clearance of valve stems in guides.

Hard starting or loss of power accompanied by high fuel consumption may be symptoms of faulty valves. Although these symptoms could also be attributed to worn rings, remove and check valves first. After removal, clean valve heads, faces, and stems with a power wire brush.

Then, carefully inspect each valve for defects such as a warped head, excessive corrosion, or a worn stem end. Replace valves found to be in bad condition.

Valve Guides

If a valve guide is worn beyond specifications, it will not guide valve in a straight line. This may result in burnt valve faces or seats, loss of compression, and excessive oil consumption.

To check valve guide-to-valve stem clearance, thoroughly clean valve guide and, using a split-ball gauge, measure inside diameter of guide. Then, using an outside micrometer, measure diameter of valve stem at several points on stem where it moves in valve guide. Use largest stem diameter to calculate clearance by subtracting stem diameter from guide diameter. If intake clearance exceeds 0.038/0.076 mm (0.0015/0.0030 in.) or exhaust clearance exceeds 0.050/0.088 mm (0.0020/0.0035 in.), determine whether valve stem or guide is responsible for excessive clearance.

Maximum (I.D.) wear on intake valve guide is 7.134 mm (0.2809 in.) while 7.159 mm (0.2819 in.) is maximum allowed on exhaust guide. Guides are not removable but can be reamed 0.25 mm (0.010 in.) oversize. Valves with 0.25 mm oversize stems must then be used.

If guides are within limits but valve stems are worn beyond limits, install new valves.

Valve Seat Inserts

Hardened steel alloy intake and exhaust valve seat inserts are press fitted into cylinder head. Inserts are not replaceable but can be reconditioned if not too badly pitted or distorted. If cracked or badly warped, cylinder head should be replaced.

Recondition valve seat inserts following instructions provided with valve seat cutter being used. Final cut should be made with an 89° cutter as specified for valve seat angle. Cutting proper 45° valve face angle as specified, and proper valve seat angle (44.5°, half of full 89° angle), will achieve desired 0.5° (1.0° full cut) interference angle where maximum pressure occurs on outside diameters of valve face and seat.

Lapping Valves

NOTE: Exhaust valves that are black in color cannot be ground and do not require lapping.

Reground or new valves must be lapped in, to provide proper fit. Use a hand valve grinder with a suction cup for final lapping. Lightly coat valve face with a fine grade of grinding compound, then rotate valve on its seat with grinder. Continue grinding until a smooth surface is obtained on seat and on valve face. Thoroughly clean cylinder head in soap and hot water to remove all traces of grinding compound. After drying cylinder head, apply a light coating of SAE 10 oil to prevent rusting.

Intake Valve Stem Seal

These engines use valve stem seals on intake valves. Always use a new seal when valves are removed from cylinder head. Seals should also be replaced if deteriorated or damaged in any way. Never reuse an old seal.

Hydraulic Lifters Inspection

Check base surface of hydraulic lifters for wear or damage. If lifters need to be replaced, apply a liberal coating of Rehlko lubricant to base of each new lifter before it is installed.

Bleeding Lifters

To prevent a possible bent push rod or broken rocker arm, it is important to bleed any excess oil out of lifters before they are installed.

1. Cut a 50-75 mm (2-3 in.) piece from end of an old push rod and chuck it in a drill press.
2. Lay a rag or shop towel on table of drill press and place lifter, open end up, on towel.
3. Lower chucked push rod until it contacts plunger in lifter. Slowly pump plunger 2 or 3 times to force oil out of feed hole in side of lifter.

Disassembly/Inspection and Service

Flywheel/Ignition Components

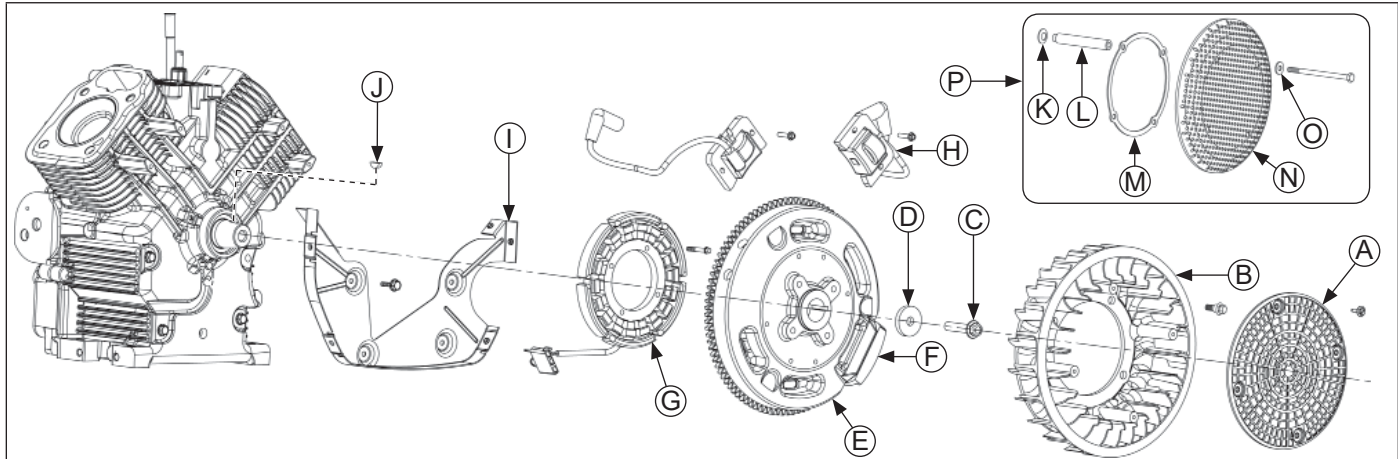

A	Debris Screen	B	Fan	C	Flywheel Screw	D	Washer
E	Flywheel	F	Magnet	G	Stator	H	Ignition Module
I	Backing Plate	J	Woodruff Key	K	Spring Washer	L	Spacer
M	Ring Support	N	Metal Debris Screen	O	Washer	P	Metal Debris Screen Assembly

Remove Ignition Modules

1. Disconnect lead(s) from each ignition module. Modules for non-SMART-SPARK™ ignition systems have only one kill lead.
2. Rotate flywheel so magnet is away from modules.
3. Remove mounting screws and ignition modules. Note position of ignition modules.

Inspection

Inspect flywheel for cracks and flywheel keyway for damage. Replace flywheel if it is cracked. Replace flywheel, crankshaft, and key if flywheel key is sheared or keyway is damaged.

Inspect ring gear for cracks or damage. Rehlko does not provide ring gear as a serviceable part. Replace flywheel if ring gear is damaged.

Remove Debris Screen and Fan

1. Small metal retainers are typically attached on 3 of 7 mounting posts for positive retention of plastic debris screen. Use a hook-end tool next to post and pull outward to separate small metal retainers. Then unsnap fan from remaining mounting posts.
2. Remove screws and fan.

Remove Stator and Backing Plates

1. Remove screws securing backing plates and stator wire bracket (if equipped). Remove backing plates and stator wire bracket.
2. Remove screws and stator.

Remove Flywheel

NOTE: Always use a flywheel strap wrench or holding tool to hold flywheel when loosening or tightening flywheel screw. Do not use any type of bar or wedge to hold flywheel. Use of such tools could cause flywheel to become cracked or damaged.

NOTE: Always use a flywheel puller to remove flywheel from crankshaft. Do not strike crankshaft or flywheel, as these parts could become cracked or damaged. Striking puller or crankshaft can cause crank gear to move, affecting crankshaft end play.

1. Use a flywheel strap wrench or holding tool (see Tools and Aids) to hold flywheel and loosen screw securing flywheel to crankshaft.
2. Remove screw and washer.
3. Use a puller to remove flywheel from crankshaft.
4. Remove woodruff key from crankshaft.

Crankcase Components

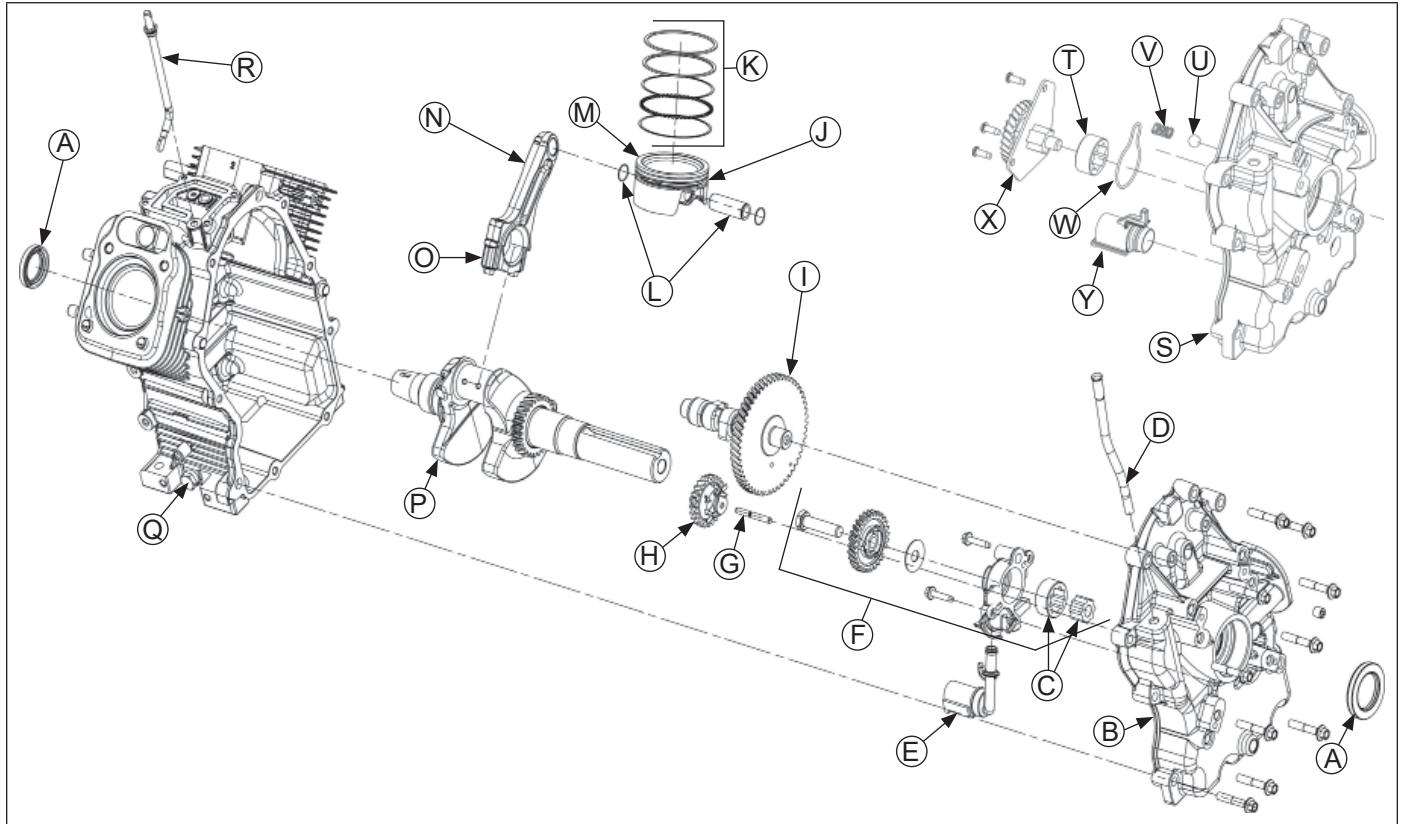

A	Oil Seal	B	Closure Plate (Style A)	C	Gerotor Gears (Style A)	D	Dipstick Tube
E	Oil Pick-Up Tube (Style A)	F	Oil Pump Assembly (Style A)	G	Governor Gear Shaft	H	Governor Gear
I	Camshaft	J	Piston Pin	K	Piston Ring Set	L	Piston Pin Retainer
M	Piston	N	Connecting Rod	O	Connecting Rod End Cap	P	Crankshaft
Q	Oil Drain Plug	R	Governor Cross Shaft	S	Closure Plate (Style B)	T	Outer Gerotor Gear (Style B)
U	Ball (Style B)	V	Spring (Style B)	W	Oil Pump Cover O-ring (Style B)	X	Oil Pump Assembly (Style B)
Y	Oil Pick-Up Tube (Style B)						

Remove Closure Plate Assembly

1. Remove screws securing closure plate to crankcase.
2. Locate splitting tabs cast into perimeter of closure plate. Insert drive end of a 1/2 in. breaker bar between top splitting tab and crankcase. Hold handle horizontal and pull toward you to break RTV seal. If necessary, pry at bottom tabs also. Do not pry on sealing surfaces as this could cause leaks. Carefully pull closure plate from crankcase.

Inspection

Inspect oil seal in closure plate and remove it if it is worn or damaged. Refer to Install Closure Plate Oil Seal in Reassembly for new oil seal installation.

Inspect main bearing surface for wear or damage. Refer to specifications. Replace closure plate assembly if required.

Disassembly/Inspection and Service

Governor Gear Assembly

Governor Shaft Component and Details

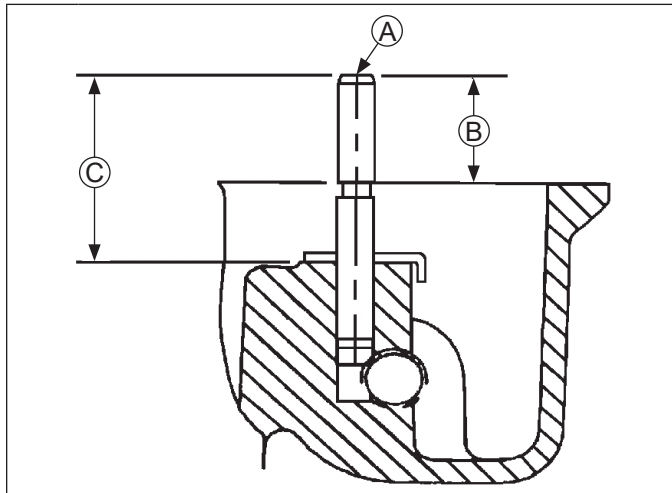

A	Gear Shaft
B	19.40 mm (0.7638 in.)
C	34.0 mm (1.3386 in.) 33.5 mm (1.3189 in.)

Governor gear assembly is located inside closure plate. If service is required, refer to Inspection, Disassembly, and Reassembly procedures.

Inspection

Inspect governor gear teeth. Replace gear if it is worn, chipped, or if any teeth are missing. Inspect governor weights. They should move freely in governor gear.

Disassembly

NOTE: Governor gear is held onto shaft by small molded tabs in gear. When gear is removed from shaft, these tabs are destroyed and gear must be replaced. Therefore, remove gear only if absolutely necessary.

Governor gear must be replaced once it is removed from closure plate.

1. Remove regulating pin and governor gear assembly.
2. Remove locking tab thrust washer located under governor gear assembly.
3. Carefully inspect governor gear shaft and replace it only if it is damaged. After removing damaged shaft, press or lightly tap replacement shaft into closure plate to depth shown.

Reassembly

1. Install locking tab thrust washer on governor gear shaft with tab down.
2. Position regulating pin within governor gear/flyweight assembly and slide both onto governor shaft.

Oil Pump Assembly (Style A)

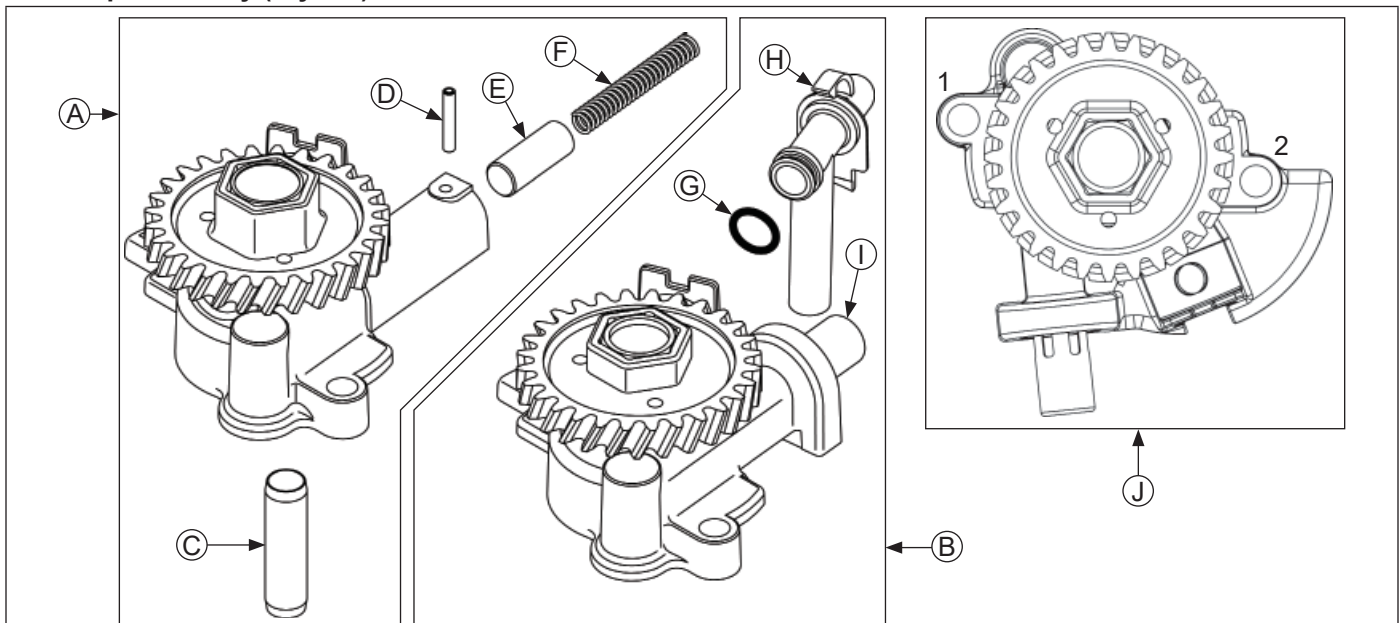

A	Oil Pump (Original Style A)	B	Oil Pump (Later Style A)	C	Oil Pickup Tube	D	Roll Pin
E	Piston	F	Spring	G	O-ring	H	Plastic Oil Pickup
I	One-Piece Relief Valve	J	Torque Sequence (Style A)				

Oil Pump Assembly (Style A)

Oil pump is mounted inside closure plate. If service is required, continue with Disassembly, Inspection, and Reassembly.

Disassembly

1. Remove screws.
2. Remove oil pump assembly from closure plate.
3. Remove oil pump rotor.
4. Remove oil pickup by unhooking locking clip, and pulling it free from oil pump body.
5. If relief valve is similar to shown, drive out pin to remove oil pressure relief valve piston and spring. Refer to following inspection and reassembly procedures.

If relief valve is a one-piece style, staked to oil pump housing removal should not be attempted, nor is internal servicing possible. If a problem with relief valve is encountered, oil pump should be replaced.

Inspection

Inspect oil pump housing, gear, and rotors for nicks, burrs, wear, or any visible damage. If any parts are worn or damaged, replace oil pump.

Inspect oil pressure relief valve piston. It should be free of nicks or burrs.

Check spring for wear or distortion. Free length of spring should be approximately 47.4 mm (1.8 in.). Replace spring if it is distorted or worn.

Reassembly

1. Install pressure relief valve piston and spring.
2. Install oil pickup to oil pump body. Lubricate O-ring with oil and make sure it remains in groove as pickup is being installed.
3. Install rotor.
4. Install oil pump body to closure plate and secure with screws. Torque screws as follows:
 - a. Install fastener into screw location 1 and lightly tighten to position pump.
 - b. Install fastener into screw location 2 and fully torque to recommended value.
 - c. Torque fastener in screw location 1 to recommended value.
First Time Installation: 10.7 N·m (95 in. lb.)
All Reinstallations: 6.7 N·m (60 in. lb.)
5. After torquing, rotate gear and check for freedom of movement. Make sure there is no binding. If binding occurs, loosen screws, reposition pump, retorquer screws and recheck movement.

Oil Pump Assembly (Style B)

Oil pump is mounted inside closure plate. If service is required, continue with Disassembly, Inspection, and Reassembly.

Disassembly

1. Remove screws.
2. Lift oil pump assembly from closure plate. Remove outer gerotor gear from closure plate.
3. Ensure ball and spring remain installed in pressure relief hole of closure plate. If ball and spring fall out of pressure relief hole, see reassembly for correct installation.
4. Remove oil pump cover O-ring from groove in closure plate.

Inspection

Inspect oil pump housing, gear, and rotors for nicks, burrs, wear, or any visible damage. Inspect oil pump cover O-ring for cuts, nicks, or any visible damage. If any parts are worn or damaged, replace oil pump assembly and/or O-ring. Check oil pickup screen for damage or restriction, replace if necessary.

Reassembly

1. Lubricate outer gerotor gear with oil. Install outer gerotor gear through shaft of oil pump, around inner gerotor gear. Matching molding dots on inner and outer gerotor gears is not necessary and will not affect oil pump efficiency.
2. Reinstall ball, then spring into pressure relief hole in closure plate.
3. Reinstall O-ring into groove in closure plate; make sure it is fully seated in groove.
4. Install oil pump inserting center shaft into corresponding recess in closure plate. Apply consistent downward pressure to oil pump cover, compressing oil pressure relief spring and start screws. Secure oil pump by torquing screws (in no specific sequence) to 9.0 N·m (80 in. lb.).
5. After torquing, rotate gear and check for freedom of movement. Make sure there is no binding. If binding occurs, loosen screws, reposition pump, retorquer screws and recheck movement.

Remove Camshaft

Remove camshaft and shim.

Inspection and Service

NOTE: To prevent repeat failures, camshaft and crankshaft should always be replaced as a set.

Check lobes of camshaft for wear or damage. See Specifications for minimum lift tolerance. Inspect cam gear for badly worn, chipped or missing teeth. Replacement of camshaft will be necessary if any of these conditions exist.

Disassembly/Inspection and Service

Remove Connecting Rods with Pistons and Rings

NOTE: If a carbon ridge is present at top of either cylinder bore, use a ridge reamer tool to remove ridge before attempting to remove piston.

NOTE: Cylinders are numbered on crankcase. Use numbers to mark each end cap, connecting rod and piston for reassembly. Do not mix end caps and connecting rods.

1. Remove screws securing closest connecting rod end cap. Remove end cap.
2. Carefully remove connecting rod and piston assembly from cylinder bore.
3. Repeat above procedures for other connecting rod and piston assembly.

Piston and Rings

Piston and Rings Components and Details

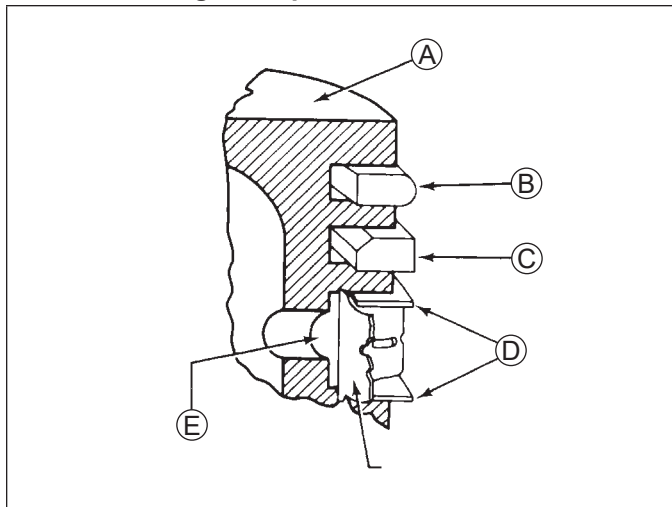

A	Piston	B	Top Compression Ring
C	Middle Compression Ring	D	Rails
E	Expander	F	Oil Control Ring (3 Piece)

NOTE: Rings must be installed correctly. Ring installation instructions are usually included with new ring sets. Follow instructions carefully. Use a piston ring expander to install rings. Install bottom (oil control) ring first and top compression ring last.

Scuffing and scoring of pistons and cylinder walls occurs when internal engine temperatures approach welding point of piston. Temperatures high enough to do this are created by friction, which is usually attributed to improper lubrication and/or overheating of engine.

Normally, very little wear takes place in piston boss-piston pin area. If original piston and connecting rod can be reused after new rings are installed, original pin can also be reused but new piston pin retainers are required. Piston pin is included as part of piston assembly – if pin boss in piston or pin are worn or damaged, a new piston assembly is required.

Ring failure is usually indicated by excessive oil consumption and blue exhaust smoke. When rings fail, oil is allowed to enter combustion chamber where it is burned along with fuel. High oil consumption can also occur when piston ring end gap is incorrect because ring cannot properly conform to cylinder wall under this condition. Oil control is also lost when ring gaps are not staggered during installation.

When cylinder temperatures get too high, lacquer and varnish collect on pistons causing rings to stick, which results in rapid wear. A worn ring usually takes on a shiny or bright appearance.

Scratches on rings and pistons are caused by abrasive material such as carbon, dirt, or pieces of hard metal.

Detonation damage occurs when a portion of fuel charge ignites spontaneously from heat and pressure shortly after ignition. This creates two flame fronts which meet and explode to create extreme hammering pressures on a specific area of piston. Detonation generally occurs from using low octane fuels.

Preignition or ignition of fuel charge before timed spark can cause damage similar to detonation. Preignition damage is often more severe than detonation damage. Preignition is caused by a hot spot in combustion chamber from sources such as glowing carbon deposits, blocked cooling fins, an improperly seated valve, or wrong spark plug(s).

Replacement pistons are available in STD bore size, and in 0.25 mm (0.010 in.), and 0.50 mm (0.020 in.) oversize. Replacement pistons include new piston ring sets and new piston pins.

Replacement ring sets are also available separately for STD, 0.25 mm (0.010 in.), and 0.50 mm (0.020 in.) oversize pistons. Always use new piston rings when installing pistons. Never use old rings.

Some important points to remember when servicing piston rings:

1. Cylinder bore must be deglazed before service ring sets are used.
2. If cylinder bore does not need reboring and if old piston is within wear limits and free of score or scuff marks, old piston may be reused.
3. Remove old rings and clean up grooves. Never reuse old rings.
4. Before installing new rings on piston, place top two rings, each in turn, in its running area in cylinder bore and check end gap. Compare ring gap to tolerances listed in Specifications.
5. After installing new compression (top and middle) rings on piston, check piston-to-ring side clearance. Compare clearance to tolerance listed in Specifications. If side clearance is greater than specified, a new piston must be used.

To install new piston rings, proceed as follows:

1. Oil control ring (bottom groove): Install expander and then rails. Make sure ends of expander are not overlapped.
2. Middle compression ring (center groove): Install center ring using a piston ring installation tool. Make sure identification mark is up or dye colored stripe (if contained) is to left of end gap.
3. Top compression ring (top groove): Install top ring using a piston ring expander. Make sure identification mark is up or dye colored stripe (if contained), left of end gap.

Install New Piston Rings

Piston Ring Orientation

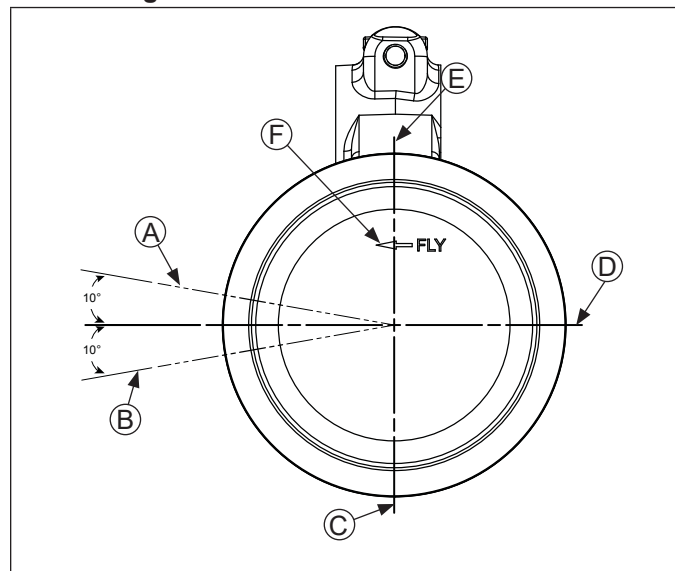

A	Top Oil Ring Rail Gap	B	Bottom Oil Ring Rail Gap
C	Intermediate Ring Gap	D	Oil Ring Expander Gap
E	Top Ring Gap	F	FLY Stamp

NOTE: Rings must be installed correctly. Ring installation instructions are usually included with new ring sets. Follow instructions carefully. Use a piston ring expander to install rings. Install bottom (oil control) ring first and top compression ring last.

To install new piston rings, proceed as follows:

1. Oil control ring (bottom groove): Install expander and then rails. Make sure ends of expander are not overlapped.
2. Middle compression ring (center groove): Install center ring using a piston ring installation tool. Make sure identification mark is up or colored dye stripe (if contained), is to left of end gap.
3. Top compression ring (top groove): Install top ring using a piston ring expander. Make sure identification mark is up or colored dye stripe (if contained), is to left of end gap.

Disassembly/Inspection and Service

Connecting Rods

Offset, stepped-cap connecting rods are used in all these engines.

Inspection and Service

Check bearing area (big end) for excessive wear, score marks, running and side clearances (refer to Specifications). Replace rod and cap if scored or excessively worn.

Service replacement connecting rods are available in STD crankpin size and 0.25 mm (0.010 in.) undersize. An 0.25 mm (0.010 in.) undersized rod can be identified by a drilled hole located in lower end of rod shank. Always refer to appropriate parts information to ensure correct replacements are used.

Remove Crankshaft

Inspection and Service

Crankshaft Components and Details

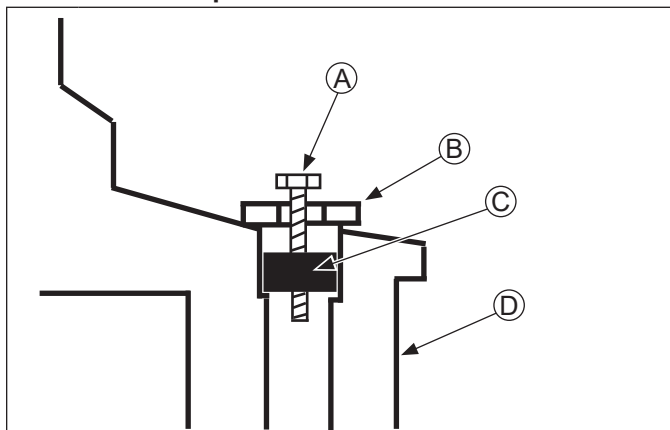

A	Self-Tapping Screw	B	Flat Washer
C	Plug	D	Crankshaft

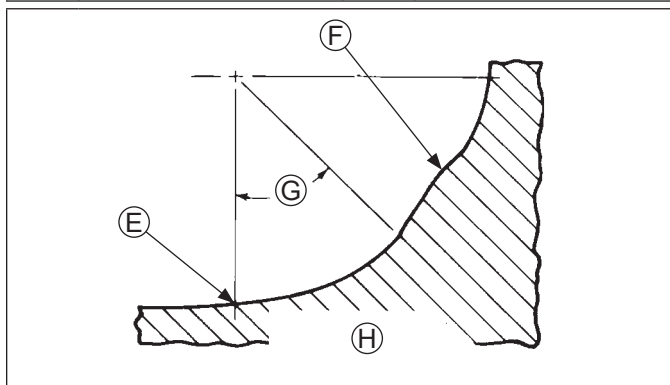

E	Fillet Must Blend Smoothly with Bearing Journal Surface
F	High Point from Fillet Intersections
G	45° Minimum
H	This Fillet Area Must Be Completely Smooth

NOTE: If crankpin is reground, visually check to ensure fillet blends smoothly with crankpin surface.

NOTE: To prevent repeat failures, camshaft and crankshaft should always be replaced as a set.

Carefully pull crankshaft from crankcase. Note thrust washers and shims if used.

Inspect gear teeth of crankshaft. If teeth are badly worn, chipped, or some are missing, replacement of crankshaft will be necessary.

Inspect crankshaft bearing surfaces for scoring, grooving, etc. Some engines have bearing inserts in crankshaft bore of closure plate and/or crankcase. Do not replace bearings unless they show signs of damage or are out of running clearance specifications. If crankshaft turns easily and noiselessly, and there is no evidence of scoring, grooving, etc., on races or bearing surfaces, bearings can be reused.

Inspect crankshaft keyways. If they are worn or chipped, replacement of crankshaft will be necessary.

Inspect crankpin for score marks or metallic pickup. Slight score marks can be cleaned with crocus cloth soaked in oil. If wear limits, as stated in Specifications and Tolerances are exceeded, it will be necessary to either replace crankshaft or regrind crankpin to 0.25 mm (0.010 in.) undersize. If reground, a 0.25 mm (0.010 in.) undersize connecting rod (big end) must then be used to achieve proper running clearance. Measure crankpin for size, taper, and out-of-round.

Connecting rod journal can be ground one size under. When grinding a crankshaft, grinding stone deposits can get caught in oil passages, which could cause severe engine damage. Removing crankpin plug when crankshaft is ground provides easy access for removing any grinding deposits collected in oil passages.

Use following procedure to remove and replace plug.

Procedure to Remove Crankshaft Plug:

1. Drill a 3/16 in. hole through plug in crankshaft.
2. Thread a 3/4 in. or 1 in. long self-tapping screw with a flat washer into drilled hole. Flat washer must be large enough to seat against shoulder of plug bore.
3. Tighten self-tapping screw until it draws plug out of crankshaft.

Procedure to Install New Plug:

Use 1 single cylinder camshaft pin as a driver and tap plug into plug bore until it seats at bottom of bore. Make sure plug is tapped in evenly to prevent leakage.

Remove Governor Cross Shaft

1. Remove hitch pin and plain washer, or retainer and nylon washer from governor cross shaft.
2. Pull cross shaft with small washer out through inside of crankcase.

Governor Cross Shaft Oil Seal

Cross Shaft Oil Seal Details

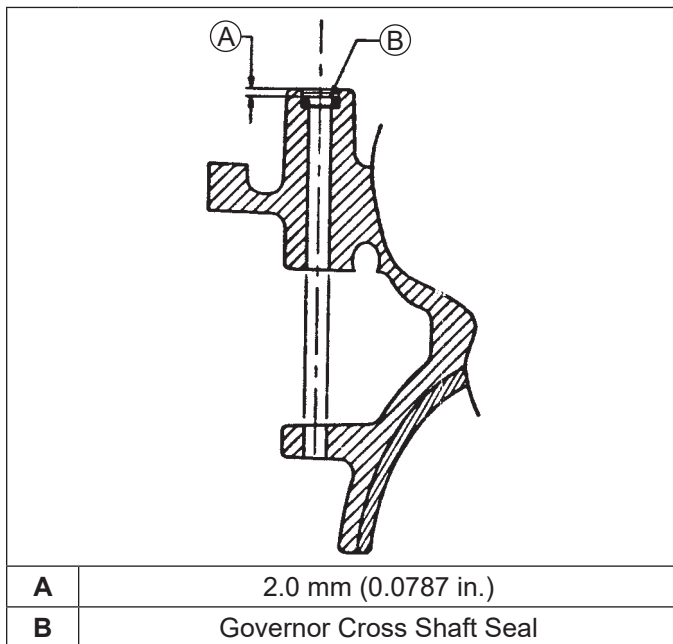

If governor cross shaft seal is damaged and/or leaks, replace it using following procedure.

Remove oil seal from crankcase and replace it with a new one. Install new seal to depth shown using a seal installer.

Remove Flywheel End Oil Seal

Remove oil seal from crankcase.

Crankcase

Inspection and Service

Check all gasket surfaces to make sure they are free of gasket fragments. Gasket surfaces must also be free of deep scratches or nicks.

Inspect main bearing (if equipped) for wear or damage. Replace crankcase using a miniblock or short block as required.

Check cylinder bore wall for scoring. In severe cases, unburned fuel can cause scuffing and scoring of cylinder wall. It washes necessary lubricating oils off piston and cylinder wall. As raw fuel seeps down cylinder wall, piston rings make metal to metal contact with wall. Scoring of cylinder wall can also be caused by localized hot spots resulting from blocked cooling fins or from inadequate or contaminated lubrication.

If cylinder bore is badly scored, excessively worn, tapered, or out-of-round, resizing is necessary. Use an inside micrometer to determine amount of wear (refer to Specifications), then select nearest suitable oversize of either 0.25 mm (0.010 in.) or 0.50 mm (0.020 in.). Resizing to one of these oversizes will allow usage of available oversize piston and ring assemblies. First, resize using a boring bar, then follow these procedures for honing cylinder.

Honing

Detail

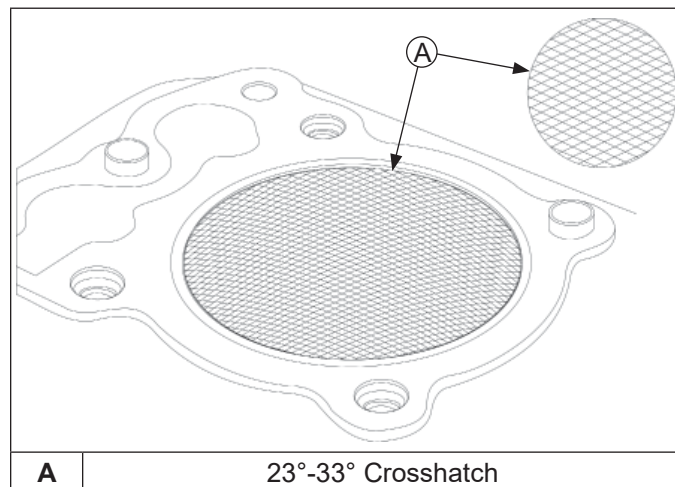

NOTE: Some CH25 engines feature POWER-BORE™ cylinders a special patented nickel-silicone plating process for increased power, superior oil control, reduced exhaust emission, and virtually permanent cylinder life. POWER-BORE™ cylinders cannot be resized or honed as described in these procedures. If a plated cylinder bore is damaged or out of specification, use a new miniblock or short block to repair engine. Use following procedure for crankcases with a cast iron sleeve.

NOTE: Rehlko pistons are custom-machined to exacting tolerances. When oversizing a cylinder, it should be machined exactly 0.25 mm (0.010 in.) or 0.50 mm (0.020 in.) over new diameter (refer to Specifications). A corresponding oversize Rehlko replacement piston will then fit correctly.

While most commercially available cylinder hones can be used with either portable drills or drill presses, use of a low speed drill press is preferred as it facilitates more accurate alignment of bore in relation to crankshaft crossbore. Honing is best accomplished at a drill speed of about 250 RPM and 60 strokes per minute. After installing coarse stones in hone, proceed as follows:

1. Lower hone into bore and after centering, adjust so stones are in contact with cylinder wall. Use of a commercial cutting-cooling agent is recommended.
2. With lower edge of each stone positioned even with lowest edge of bore, start drill and honing process. Move hone up and down while resizing to prevent formation of cutting ridges. Check size frequently.
3. When bore is within 0.064 mm (0.0025 in.) of desired size, remove coarse stones and replace them with burnishing stones. Continue with burnishing stones until bore is within 0.013 mm (0.0005 in.) of desired size and then use finish stones (220-280 grit) and polish bore to its final size. A crosshatch should be observed if honing is done correctly. Crosshatch should intersect at approximately 23°-33° off horizontal. Too flat an angle could cause rings to skip and wear excessively, and too steep an angle will result in high oil consumption.

Disassembly/Inspection and Service

- After resizing, check bore for roundness, taper, and size. Use an inside micrometer, telescoping gauge, or bore gauge to take measurements. These measurements should be taken at 3 locations in cylinder—at top, middle, and bottom. There are 2 measurements that should be taken (perpendicular to each other) at all 3 locations.

Clean Cylinder Bore After Honing

Proper cleaning of cylinder walls following boring and/or honing is very critical to a successful overhaul. Machining grit left in cylinder bore can destroy an engine in less than one hour of operation after a rebuild.

Final cleaning operation should always be a thorough scrubbing with a brush and hot, soapy water. Use a strong detergent capable of breaking down machining oil while maintaining a good level of suds. If suds break down during cleaning, discard dirty water and start again with more hot water and detergent. Following scrubbing, rinse cylinder with very hot, clear water, dry it completely, and apply a light coating of engine oil to prevent rusting.

Measuring Piston-to-Bore Clearance

Piston Detail

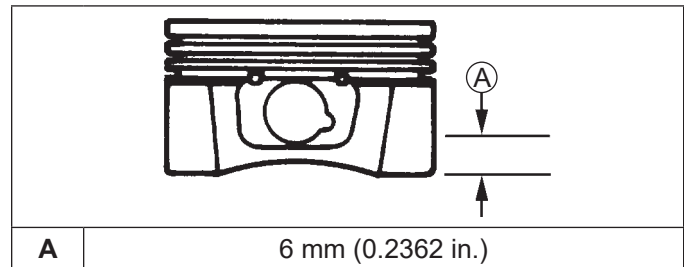

NOTE: Do not use a feeler gauge to measure piston-to-bore clearance—it will yield inaccurate measurements. Always use a micrometer.

Before installing piston into cylinder bore, it is necessary clearance be accurately checked. This step is often overlooked, and if clearances are not within specifications, engine failure will usually result.

Use following procedure to accurately measure piston-to-bore clearance:

- Use a micrometer and measure diameter of piston 6 mm (0.2362 in.) above bottom of piston skirt and perpendicular to piston pin.
- Use an inside micrometer, telescoping gauge, or bore gauge and measure cylinder bore. Take measurement approximately 63.5 mm (2.5 in.) below top of bore and perpendicular to piston pin.
- Piston-to-bore clearance is difference between bore diameter and piston diameter (step 2 minus step 1).

Crankcase Components

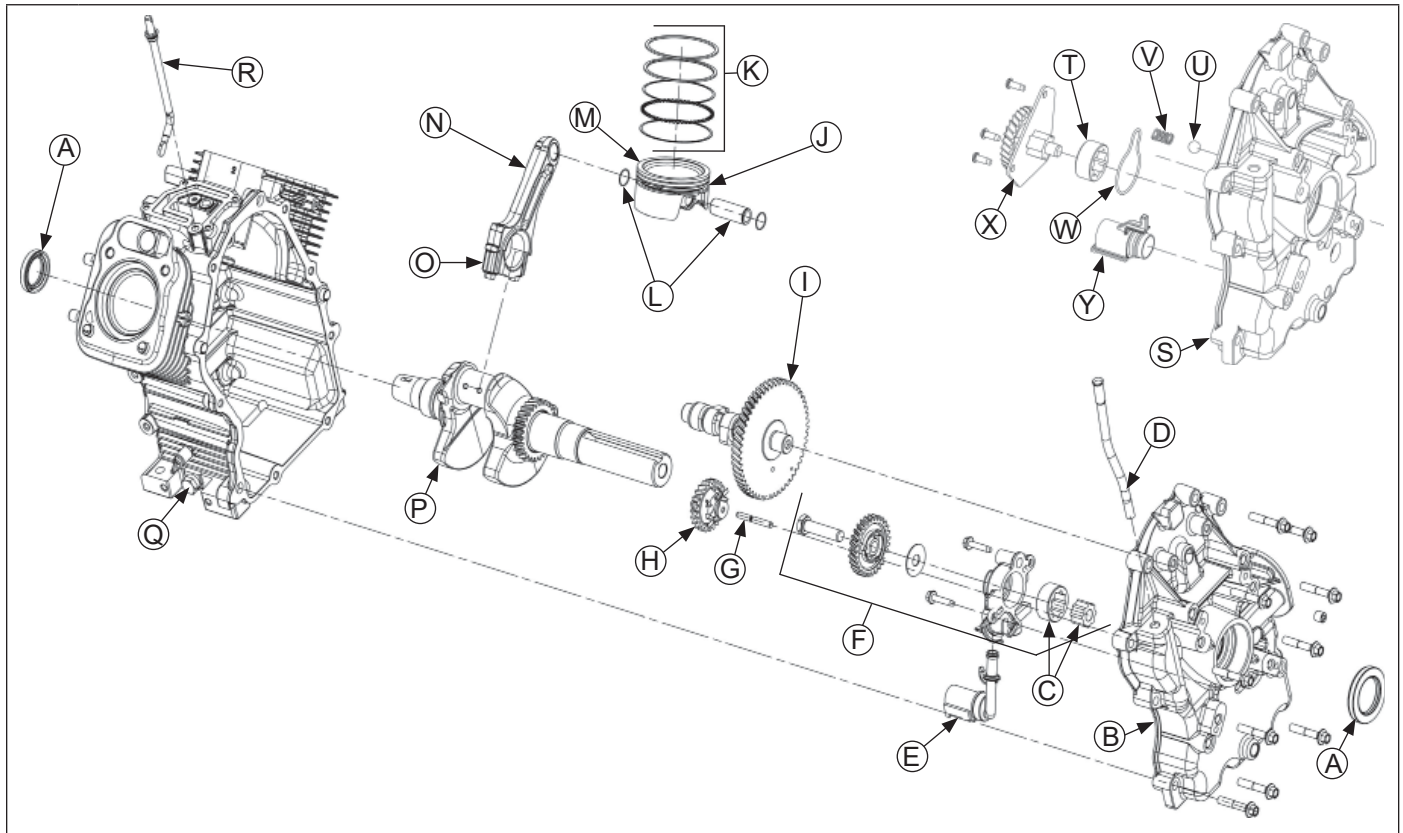

A	Oil Seal	B	Closure Plate (Style A)	C	Gerotor Gears (Style A)	D	Dipstick Tube
E	Oil Pick-Up Tube (Style A)	F	Oil Pump Assembly (Style A)	G	Governor Gear Shaft	H	Governor Gear
I	Camshaft	J	Piston Pin	K	Piston Ring Set	L	Piston Pin Retainer
M	Piston	N	Connecting Rod	O	Connecting Rod End Cap	P	Crankshaft
Q	Oil Drain Plug	R	Governor Cross Shaft	S	Closure Plate (Style B)	T	Outer Gerotor Gear (Style B)
U	Ball (Style B)	V	Spring (Style B)	W	Oil Pump Cover O-ring (Style B)	X	Oil Pump Assembly (Style B)
Y	Oil Pick-Up Tube (Style B)						

NOTE: Make sure engine is assembled using all specified torque values, tightening sequences and clearances. Failure to observe specifications could cause severe engine wear or damage. Always use new gaskets. Apply a small amount of oil to threads of critical fasteners before assembly, unless a sealant or Loctite® is specified or preapplied.

Make sure all traces of any cleaner are removed before engine is assembled and placed into operation. Even small amounts of these cleaners can quickly break down lubricating properties of engine oil.

Check closure plate, crankcase, cylinder heads, and valve covers to be certain all old sealing material has been removed. Use gasket remover, lacquer thinner, or paint remover to remove any remaining traces. Clean surfaces with isopropyl alcohol, acetone, lacquer thinner, or electrical contact cleaner.

Install Flywheel End Oil Seal

1. Make sure seal bore of crankcase is clean and free of any nicks or burrs.
2. Apply a light coat of clean engine oil to outside diameter of oil seal.
3. Drive oil seal into crankcase using a seal driver. Make sure oil seal is installed straight and true in bore and tool bottoms against crankcase.

Reassembly

Install Governor Cross Shaft

1. Lubricate governor cross shaft bearing surfaces in crankcase with engine oil.
2. Slide small lower washer onto governor cross shaft and install cross shaft from inside of crankcase.
3. 6 mm governor shaft: Install plain washer and then insert hitch pin into smaller, lower hole of governor cross shaft.
8 mm governor shaft: Install nylon washer onto governor cross shaft, then start push-on retaining ring. Hold cross shaft up in position, place a 0.50 mm (0.020 in.) feeler gauge on top of nylon washer, and push retaining ring down shaft to secure. Remove feeler gauge, which will have established proper end play.

Install Crankshaft

Carefully slide flywheel end of crankshaft through main bearing in crankcase.

Install Connecting Rods with Pistons and Rings

Piston and Connecting Rod Details

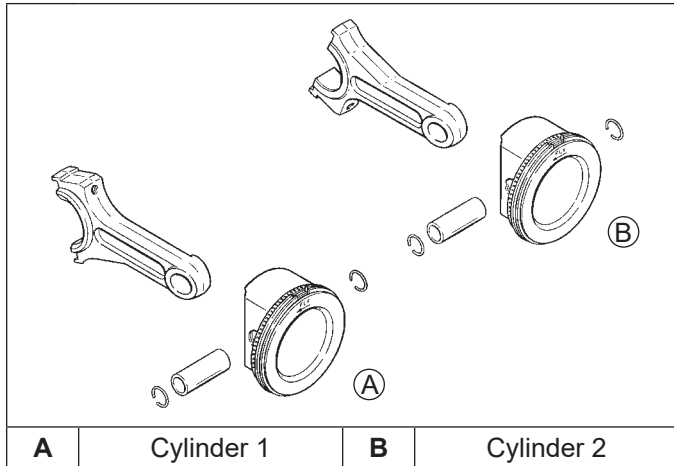

Connecting Rod Bolt Details

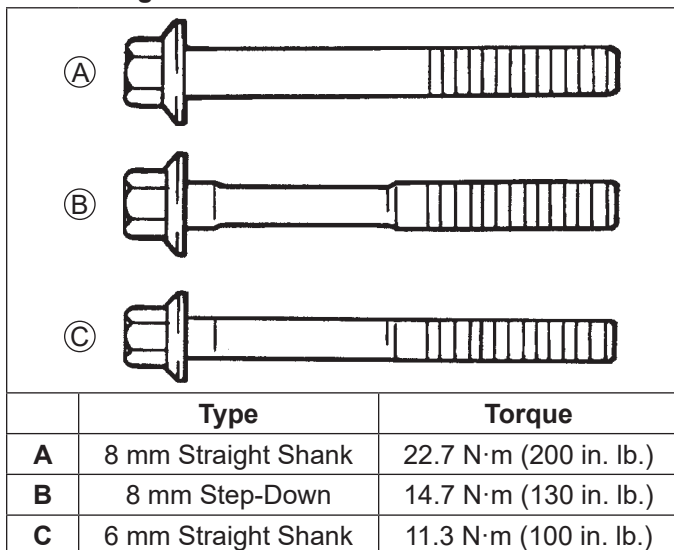

NOTE: Cylinders are numbered on crankcase. Make sure to install piston, connecting rod and end cap into its appropriate cylinder bore as previously marked at disassembly. Do not mix end caps and connecting rods.

NOTE: Proper orientation of piston/connecting rod assemblies inside engine is extremely important. Improper orientation can cause extensive wear or damage. Be certain pistons and connecting rods are assembled exactly as shown.

NOTE: Align chamfer of connecting rod with chamfer of its mating end cap. When installed, flat faces of connecting rods should face each other. Faces with raised rib should be toward outside.

1. If piston rings were removed, see Disassembly/ Inspection and Service procedure to install new rings.
2. Lubricate cylinder bore, piston, and piston rings with engine oil. Compress rings of piston 1 using a piston ring compressor.
3. Lubricate crankshaft journals and connecting rod bearing surfaces with engine oil.
4. Make sure FLY stamping on piston is facing towards flywheel side of engine. Use a hammer with a rubber grip and gently tap piston into cylinder. Be careful oil ring rails do not spring free between bottom of ring compressor and top of cylinder.
5. Install inner rod cap to connecting rod using screws. Three different types of connecting rod bolts have been used and each has a different torque value. If 8 mm straight shank type bolts are used, torque in increments to 22.7 N·m (200 in. lb.). If 8 mm step-down bolts are used, torque in increments to 14.7 N·m (130 in. lb.). If 6 mm straight shank bolts are used, torque in increments to 11.3 N·m (100 in. lb.). Illustrated instructions are provided in service rod package.
6. Repeat above procedure for other connecting rod and piston assembly.

Install Camshaft

1. Liberally apply camshaft lubricant to each cam lobe. Lubricate camshaft bearing surfaces of crankcase and camshaft with engine oil.
2. Position timing mark of crankshaft gear at 12 o'clock position.
3. Turn governor cross shaft clockwise until lower end of shaft contacts cylinder. Make sure cross shaft remains in this position while installing camshaft.
4. Slide camshaft into bearing surface of crankcase, positioning timing mark of camshaft gear at 6 o'clock position. Make sure camshaft gear and crankshaft gear mesh, with both timing marks aligned.

Determining Camshaft End Play

1. Install shim removed during disassembly onto camshaft.
2. Position camshaft end play checking tool on camshaft.
3. Apply pressure on camshaft end play checking tool (pushing camshaft toward crankshaft). Use a feeler gauge to measure camshaft end play between shim spacer and checking tool. Camshaft end play should be 0.076/0.127 mm (0.003/0.005 in.).
4. If camshaft end play is not within specified range, remove checking tool and replace shim as necessary.

Several color coded shims are available:

White: 0.69215/0.73025 mm (0.02725/0.02875 in.)

Blue: 0.74295/0.78105 mm (0.02925/0.03075 in.)

Red: 0.79375/0.83185 mm (0.03125/0.03275 in.)

Yellow: 0.84455/0.88265 mm (0.03325/0.03475 in.)

Green: 0.89535/0.99345 mm (0.03525/0.03675 in.)

Gray: 0.94615/0.98425 mm (0.03725/0.03875 in.)

Black: 0.99695/1.03505 mm (0.03925/0.04075 in.)

5. Reinstall end play checking tool and recheck end play.

Oil Pump Assembly

Oil pump is mounted inside closure plate. If service was required, and oil pump was removed, refer to Disassembly/Inspection and Service.

Governor Gear Assembly

Governor gear assembly is located inside closure plate. If service was required, and governor was removed, refer to Disassembly/Inspection and Service.

Thrust Bearing, Washer and Shim

Thrust Bearing, Washer, and Shim Sequence

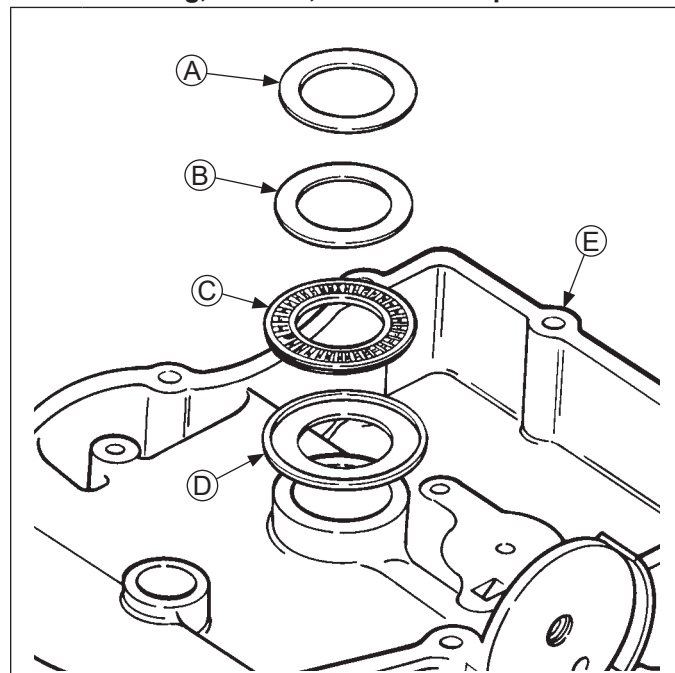

A	Thrust Shim	B	Thrust Washer
C	Needle Thrust Bearing	D	Bearing Race
E	Closure Plate		

Some specifications use a needle type thrust bearing, thrust washer and shim spacer to control end play of crankshaft. If these items are noted during disassembly, make sure they are reinstalled in sequence shown. A different procedure will have to be followed to check and adjust crankshaft end play on these models.

Race for thrust bearing presses loosely into closure plate. If it is not already installed, push it into crankshaft bore inside closure plate. Pack thrust bearing with heavy grease and stick bearing into race. Wipe some grease on face of thrust washer and stick it onto thrust bearing. Wipe some grease on face of original shim spacer and stick it onto thrust washer.

Install closure plate onto crankcase without applying RTV sealant and secure it with only two or three fasteners at this time. Use a dial indicator to check crankshaft end play. End play should be 0.070/1.190 mm (0.0028/0.0468 in.), except for CH25 engines below Serial No. 2403500008 end play should be 0.050/0.75 mm (0.0020/0.0295 in.). Shim spacers are available in three color coded thicknesses listed below if adjustment is needed.

Crankshaft End Play Shims

Green: 0.8366-0.9127 mm
(0.8750 mm/0.034 in. Nominal)

Yellow: 1.0652-1.1414 mm
(1.1033 mm/0.043 in. Nominal)

Red: 1.2938-1.3700 mm
(1.3319 mm/0.052 in. Nominal)

Reassembly

Remove closure plate. If end play requires adjustment, remove original spacer and install appropriate size shim spacer in its place. Then follow procedure under Install Closure Plate Assembly.

Install Closure Plate Oil Seal

Oil Seal Depth

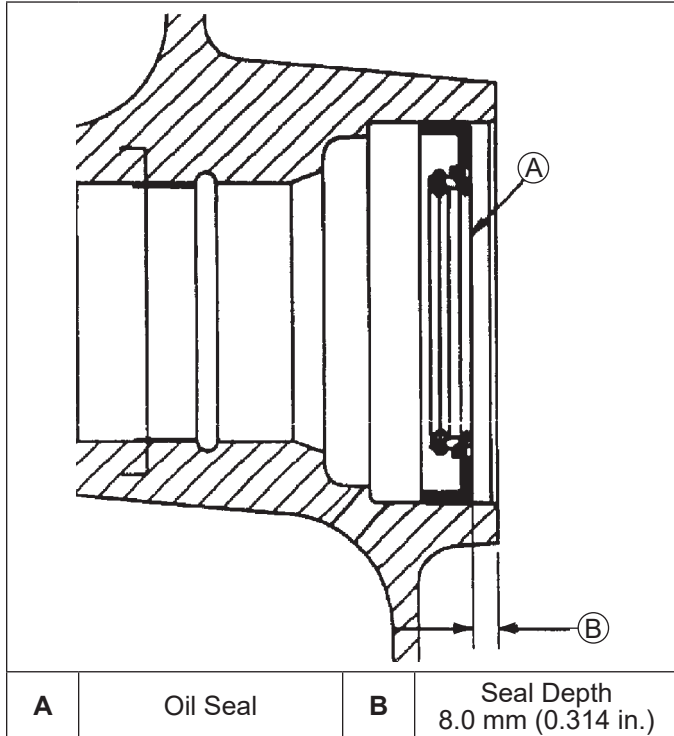

1. Check to make sure there are no nicks or burrs in crankshaft bore of closure plate.
2. Apply a light coat of engine oil to outside diameter of oil seal.
3. Drive oil seal into closure plate using a seal driver. Make sure oil seal is installed straight and true in bore to depth shown.

Install Closure Plate Assembly

Sealant Pattern and Torque Sequence

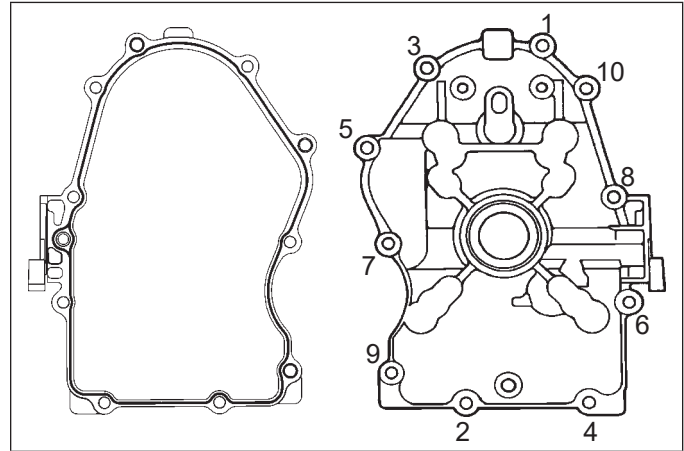

RTV sealant is used as a gasket between closure plate and crankcase. Always use fresh sealant. Using outdated sealant can result in leakage.

1. Be sure sealing surfaces have been cleaned and prepared. Install a new O-ring in closure plate.
2. Check to make sure there are no nicks or burrs on sealing surfaces of closure plate or crankcase.
3. Apply a 1.5 mm (1/16 in.) bead of sealant to sealing surface of closure plate.
4. Make sure end of governor cross shaft is lying against bottom of cylinder 1 inside crankcase.
5. Install closure plate to crankcase. Carefully seat camshaft and crankshaft into their mating bearings. Rotate crankshaft slightly to help engage oil pump and governor gear meshes.
6. Install screws securing closure plate to crankcase. Torque fasteners to 24.4 N·m (216 in. lb.) following sequence. On some engines one mounting screw is plated. Plated screw is typically installed in hole location 6. For LPG engines, install vaporizer bracket to hole locations 8 and 10.

Flywheel/Ignition Components

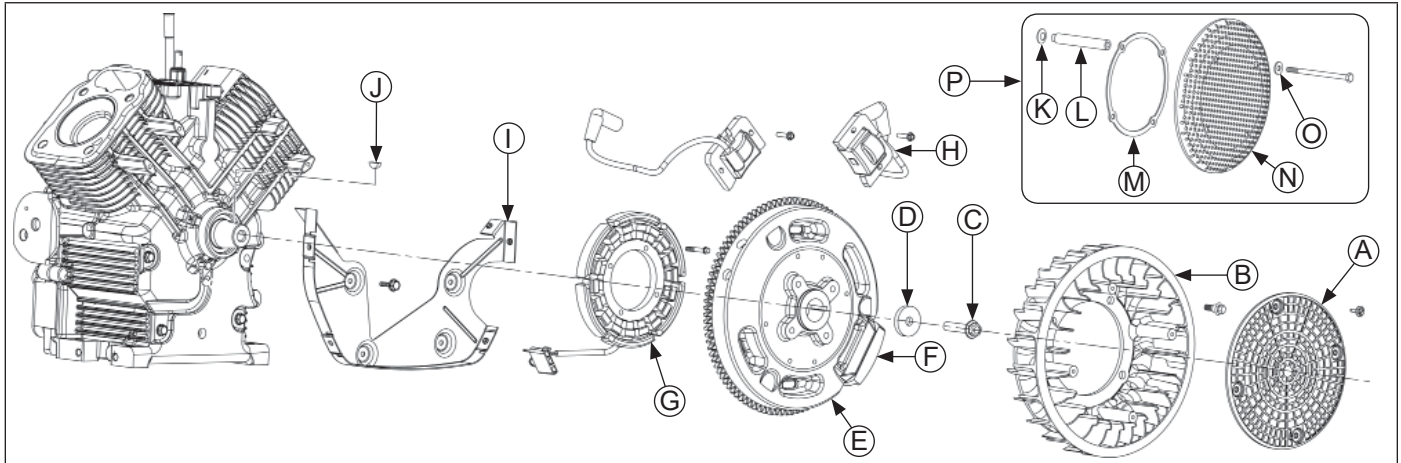

A	Debris Screen	B	Fan	C	Flywheel Screw	D	Washer
E	Flywheel	F	Magnet	G	Stator	H	Ignition Module
I	Backing Plate	J	Woodruff Key	K	Spring Washer	L	Spacer
M	Ring Support	N	Metal Debris Screen	O	Washer	P	Metal Debris Screen Assembly

Install Stator and Backing Plates

1. Apply pipe sealant with Teflon® (Loctite® PST® 592™ Thread Sealant or equivalent) to stator mounting holes.
2. Position stator aligning mounting holes so leads are at bottom, towards crankcase.
3. Install and torque screws to 6.2 N·m (55 in. lb.).
4. Route stator leads in crankcase channel, then install backing plates and stator wire bracket (if used). Secure using screws. Torque screws to 7.3 N·m (65 in. lb.).

Install Flywheel

	CAUTION
	Damaging Crankshaft and Flywheel can cause personal injury.
Using improper procedures can lead to broken fragments. Broken fragments could be thrown from engine. Always observe and use precautions and procedures when installing flywheel.	

NOTE: Before installing flywheel make sure crankshaft taper and flywheel hub are clean, dry, and completely free of any lubricants. Presence of lubricants can cause flywheel to be over stressed and damaged when screw is torqued to specifications.

NOTE: Make sure flywheel key is installed properly in keyway. Flywheel can become cracked or damaged if key is not properly installed.

1. Install woodruff key into keyway of crankshaft. Make sure key is properly seated and parallel with shaft taper.
2. Install flywheel onto crankshaft being careful not to shift woodruff key.
3. Install screw and washer.
4. Use a flywheel strap wrench or holding tool to hold flywheel. Torque screw securing flywheel to crankshaft to 66.4 N·m (49 ft. lb.).

Install Flywheel Fan

NOTE: Position ears located at rear perimeter of fan in recesses of flywheel.

1. Install fan onto flywheel using four screws.
2. Torque screws to 9.9 N·m (88 in. lb.).

Reassembly

Install Plastic Debris Screen

	⚠ CAUTION
	Failure to utilize or reassemble debris screen as designed could result in debris screen failure and serious personal injury.

If engine has a plastic debris screen, snap screen onto fan. Due to possibility of damaging posts during removal, install retainers on different posts from which they were removed. Start retainers by hand, then push them down with a 13 mm (1/2 in.) socket until they lock. If engine has a metal screen, it will be installed later.

Install Supports for Metal Debris Screen

1. If a metal debris screen is used, with threaded individual supports, install a spacer washer on external threads. Apply Loctite® 242® (removable) onto threads. Install four supports.
2. Tighten supports with a torque wrench to 9.9 N·m (88 in. lb.). Debris screen will be installed to supports after blower housing is in place.

Cylinder Head Components

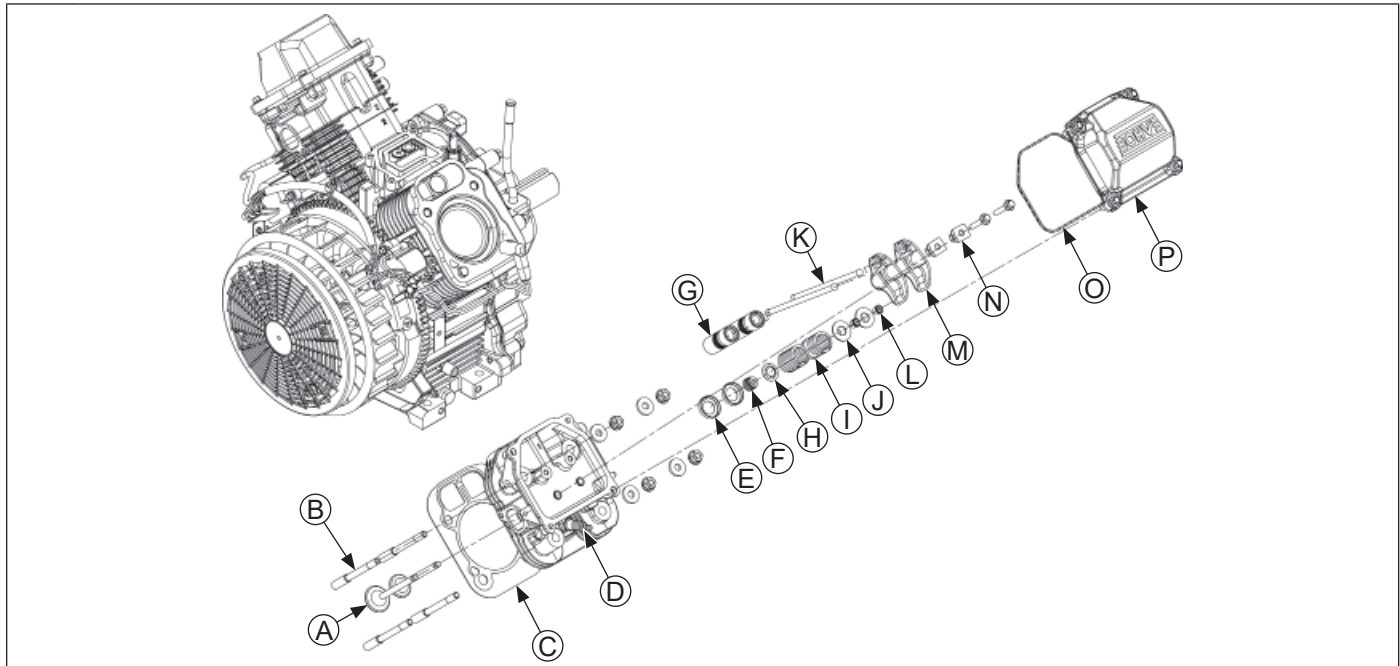

A	Valve	B	Stud	C	Gasket	D	Spark Plug
E	Cap	F	Valve Stem Seal	G	Hydraulic Lifter	H	Retainer
I	Valve Spring	J	Valve Spring Retainer	K	Push Rod	L	Valve Keeper
M	Rocker Arm	N	Rocker Arm Pivot	O	Valve Cover O-ring	P	Valve Cover

Install Hydraulic Lifters

NOTE: Hydraulic lifters should always be installed in same position as before disassembly. Exhaust lifters are located on output shaft side of engine while intake lifters are located on fan side of engine. Cylinder numbers are embossed on top of crankcase and each cylinder head.

1. Refer to Disassembly/Inspection and Service for lifter preparation (bleed down) procedures.
2. Apply camshaft lubricant to bottom surface of each lifter. Lubricate hydraulic lifters and lifter bores in crankcase with engine oil.

3. Note mark or tag identifying hydraulic lifters as either intake or exhaust and cylinder 1 or cylinder 2. Install hydraulic lifters into their appropriate location in crankcase. Do not use a magnet.

Valve Stem Seals

These engines use valve stem seals on intake valves and occasionally on exhaust valves. Always use a new seal whenever valve is removed or if seal is deteriorated or damaged in any way. Never reuse an old seal.

Assemble Cylinder Heads

Prior to installation, lubricate all components with engine oil, paying particular attention to lip of valve stem seal, valve stems and valve guides. Install in order listed below using a valve spring compressor.

- Intake and exhaust valves.
- Valve spring caps.
- Valve springs.
- Valve spring retainers.
- Valve spring keepers.

Install Cylinder Heads

Cylinder Head Torque Sequence

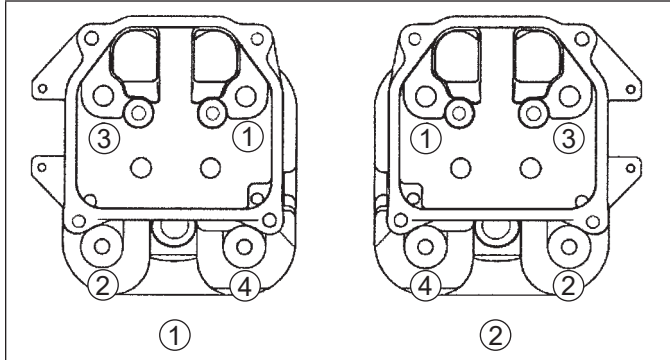

NOTE: Cylinder heads must be attached with original type of mounting hardware, using either screws, or mounting studs with nuts and washers. Heads are machined differently for studs than for screws, so fastening method cannot be altered unless heads are being replaced. Do not intermix components.

Heads secured with screws:

NOTE: Match numbers embossed on cylinder heads and crankcase.

1. Check to make sure there are no nicks or burrs on sealing surfaces of cylinder head or crankcase.
2. Install a new cylinder head gasket, (with printing up).
3. Install cylinder head and lightly lubricate threads of bolts with engine oil, but be careful not to get any oil on gasket sealing surfaces. Thread bolts in until finger tight.
4. Torque screws in two stages; first to 22.6 N·m (200 in. lb.), finally to 41.8 N·m (370 in. lb.), following sequence shown.

Heads secured with mounting studs, nuts, and washers:

1. Check to make sure there are no nicks or burrs on sealing surfaces of cylinder head or crankcase.
2. If all studs were left intact, go to Step 5. If any studs were disturbed or removed, install new studs as described in Step 3. Do not use/reinstall any loosened or removed studs.
3. Install new mounting stud(s) into crankcase.
 - a. Thread and lock two mounting nuts together on smaller diameter threads.

- b. Thread opposite end of stud with preapplied locking compound into crankcase until specified height from crankcase surface is achieved. When threading in studs, use a steady tightening motion without interruption until proper height is obtained. Otherwise, frictional heat from engaging threads may cause locking compound to set up prematurely.

Studs closest to lifters must have an exposed height of 75 mm (2 15/16 in.).

Studs furthest from lifters must have an exposed height of 69 mm (2 3/4 in.).

- c. Remove nuts and repeat procedure as required.
4. Install cylinder head. Match numbers on cylinder heads and crankcase. Make sure head is flat on gasket and dowel pins.
5. Lightly lubricate exposed (upper) threads of studs with engine oil. Install a flat washer and nut onto each mounting stud. Torque nuts in two stages; first to 16.9 N·m (150 in. lb.), finally to 35.5 N·m (315 in. lb.), following sequence shown.

Install Push Rods and Rocker Arms

NOTE: Push rods should always be installed in same position as before disassembly.

NOTE: Two different screws have been used to secure rocker arms/pivots. Black screws are used with heads that have a rocker pivot hole depth of approximately 21 mm (0.83 in.). Silver screws are used with heads that have a rocker pivot hole depth of approximately 35 mm (1.38 in.).

Early models used hollow push rods with special rocker arms. They are not interchangeable with later/current style solid push rods and associated rocker arms. Do not mix these. A replacement kit is available with solid components.

1. Note mark or tag identifying push rod as either intake or exhaust and cylinder 1 or 2. Dip ends of push rods in engine oil and install, making sure each push rod ball seats in its hydraulic lifter socket.
2. Apply grease to contact surfaces of rocker arms and rocker arm pivots. Install rocker arms and rocker arm pivots on one cylinder head, and start two screws.
3. Torque black screws to 18.1 N·m (160 in. lb.). Torque silver screws to 13.6 N·m (120 in. lb.). Repeat for other rocker arm.
4. Use a spanner wrench or rocker arm lifting tool to lift rocker arms and position push rods underneath.
5. Repeat above steps for remaining cylinder. Do not interchange parts from cylinder heads.
6. Rotate crankshaft to check for free operation of valve train. Check clearance between valve spring coils at full lift. Minimum allowable clearance is 0.25 mm (0.010 in.).

Check Assembly

Rotate crankshaft a minimum of two revolutions to check longblock assembly and overall proper operation.

Reassembly

Install Spark Plugs

1. Check gap using wire feeler gauge. Adjust gap to 0.76 mm (0.030 in.) for all except NG with CD fixed timing or 0.51 mm (0.020 in.) for NG with CD fixed timing.
2. Install plug into cylinder head.
3. Torque plug to 27 N·m (20 ft. lb.).

Install Ignition Modules

1. Rotate flywheel to position magnet away from ignition module bosses.
2. On engines equipped with SMART-SPARK™, both modules are installed with tabs out.
On engines not equipped with SMART-SPARK™, modules are installed on cylinder 1 with single kill tab should be towards you (out) and on cylinder 2 with single kill tab away from you (in).
3. Install each ignition module to crankcase bosses with screws (hex flange or allen head, based on model). Slide modules up as far away from flywheel as possible and snug screws to hold them in position.
4. Rotate flywheel to position magnet directly under one ignition module.
5. Insert a 0.30 mm (0.012 in.) flat feeler gauge between magnet and ignition module. Loosen screws enough to allow magnet to pull module down against feeler gauge.
6. Torque screws to 4.0-6.2 N·m (35-55 in. lb.).
7. Repeat steps 4 through 6 for other ignition module.
8. Rotate flywheel back and forth checking for clearance between magnet and ignition modules. Make sure magnet does not strike modules. Check gap with a feeler gauge and readjust if necessary. Final air gap: 0.280/0.330 mm (0.011/0.013 in.).

Install Intake Manifold

Torque Sequence

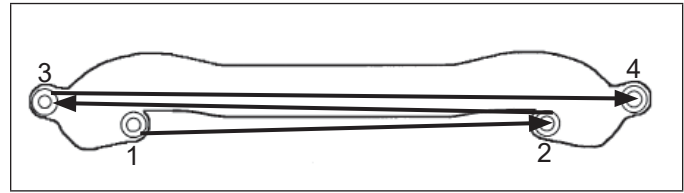

NOTE: If wires were disconnected from ignition modules on engines with SMART-SPARK™, reattach leads and seal base of terminal connectors with GE/Novaguard G661 or equivalent dielectric compound. Beads should overlap between terminals to form a solid bridge of compound. Do not put any compound inside terminals. 24 584 15-S ignition modules have a separator barrier between terminals. On these modules, seal base of terminals, but it is not necessary to have overlapping beads of sealant between connections.

1. Install intake manifold and new gaskets or O-rings (plastic manifold), with wiring harness attached, to cylinder heads. Slide any wiring harness clips onto appropriate bolts before installing. Make sure gaskets are in proper orientation. Torque screws in two stages, first to 7.4 N·m (66 in. lb.), then to 9.9 N·m (88 in. lb.), using sequence shown.
2. Connect kill lead to tab terminal on standard ignition modules.

External Engine Components

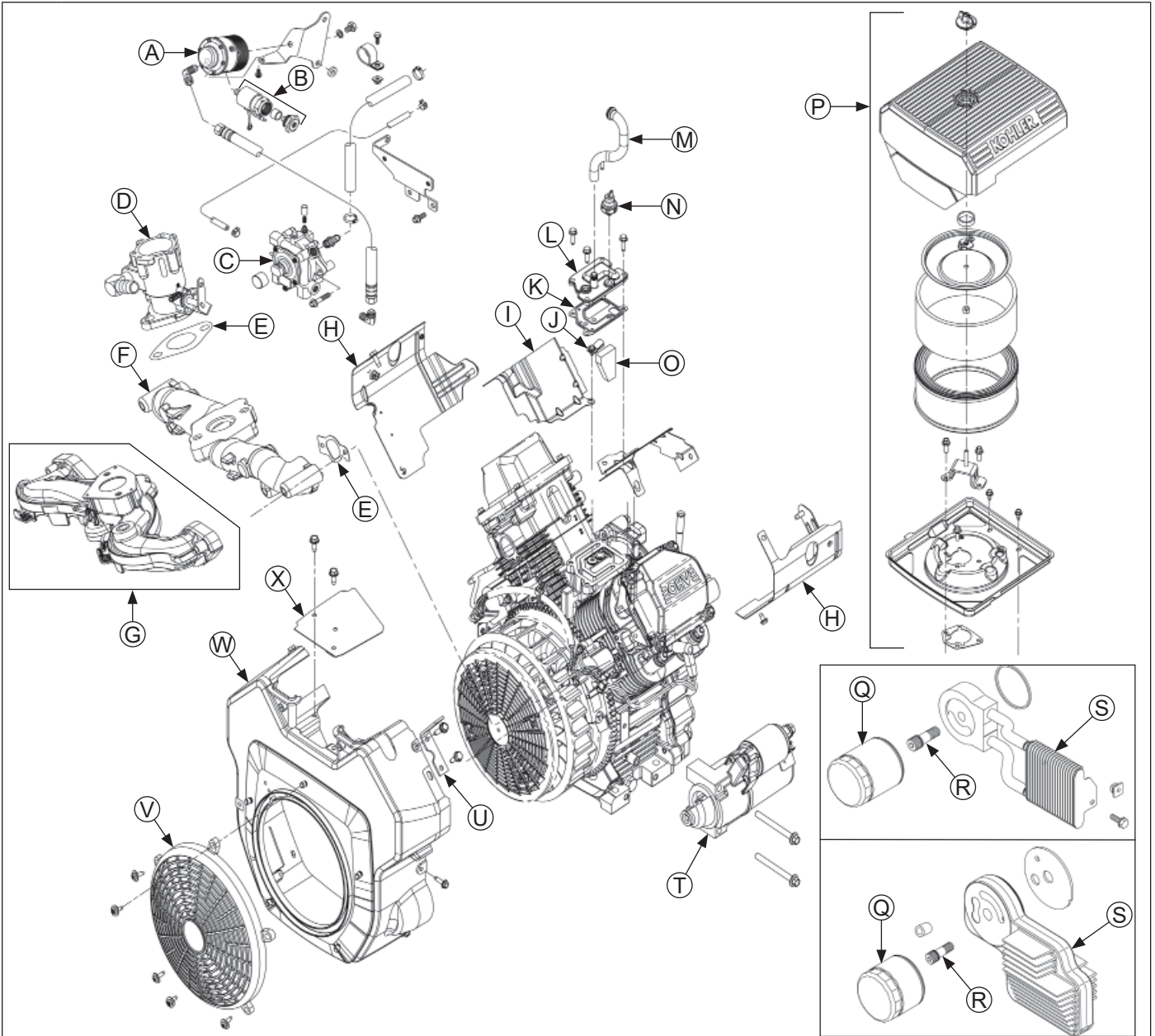

A	Vaporizer	B	Lock-off/Filter	C	Regulator	D	Carburetor
E	Gasket	F	Intake Manifold	G	Plastic Intake Manifold	H	Outer Baffle
I	Inner Baffle	J	Breather Reed	K	Breather Gasket	L	Breather Cover
M	Breather Tube	N	Oil Sentry™	O	Filter	P	Air Cleaner
Q	Oil Filter	R	Nipple	S	Oil Cooler	T	Electric Starter
U	Lifting Bracket	V	Fixed Guard	W	Blower Housing	X	Debris Shield

Reassembly

Install Breather Cover and Inner Baffles

Breather Cover Details and Torque Sequence

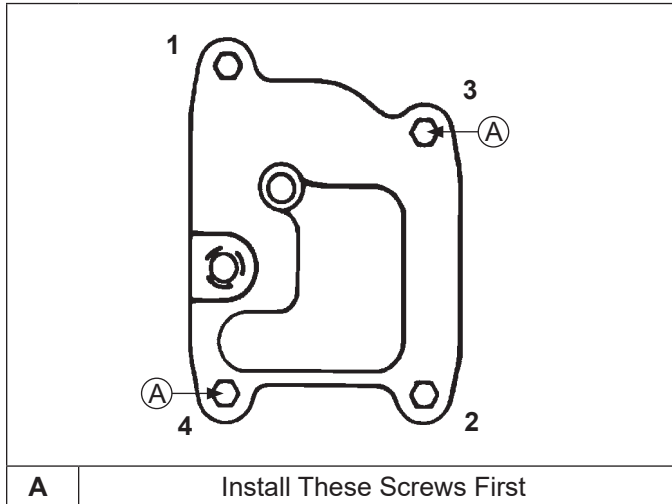

RTV sealant was used on early models between breather cover and crankcase. A gasket with imprinted sealant beads is now used and recommended. Install as follows:

1. Be sure sealing surfaces of crankcase and breather cover are clean of old gasket material or RTV sealant. Do not scrape surfaces as this could result in leakage.
2. Check to make sure there are no nicks or burrs on sealing surfaces.
3. Install breather reed and breather reed retainer onto crankcase and secure with screw. Hold assembly in line when tightening. Torque screw to 3.9 N·m (35 in. lb.).
4. Insert breather filter into position in crankcase. Make sure no filter strands are on sealing surface.
5. Install new breather gasket.
6. Carefully position breather cover on crankcase. Install first two screws at positions shown and finger tighten at this time.
7. Install inner baffles using two remaining screws and finger tighten. Do not torque screws at this time; they will be tightened after blower housing and outer baffles are installed.

Install Blower Housing and Outer Baffles

NOTE: Do not completely tighten screws until all items are installed to allow shifting for hole alignment.

1. Connect plug to key switch in blower housing (if equipped).
2. Slide blower housing into position over front edge of inner baffles. Start a few screws to hold it in place. Make sure ground lead and oil pressure switch leads are accessible and in proper position.

3. Position outer baffles and loosely start mounting screws. M6 screws go into back of cylinders. Short M5 screws go into lower holes closest to blower housing. Short screw on oil filter side is also used to mount wire harness clip. Be sure any wire harnesses or leads are routed out through proper offsets or notches, so they will not be pinched between blower housing and baffles.
4. If rectifier-regulator was not removed, attach ground wire or metal grounding bracket for rectifier-regulator, using silver colored screw and washer, to lower blower housing hole.
5. Tighten all shrouding fasteners. Torque blower housing screws to 6.2 N·m (55 in. lb.) in a new hole, or to 4.0 N·m (35 in. lb.) in a used hole. Torque shorter M5 side baffle screws to 4.0 N·m (35 in. lb.). Torque upper M5 side baffle screws (into cylinder head) to 6.2 N·m (55 in. lb.) in a new hole, or to 4.0 N·m (35 in. lb.) in a used hole. Torque two rear M6 baffle mounting screws to 10.7 N·m (95 in. lb.) in a new hole, or to 7.3 N·m (65 in. lb.) in a used hole.
6. If an overlapping style flywheel screen is used, attach it to supports or flywheel. For a metal flywheel screen, apply Loctite® 242® to screw threads (M6) and torque to 9.9 N·m (88 in. lb.). Torque plastic screen mounting screws (M4) to 2.2 N·m (20 in. lb.).
7. Torque breather cover screws to 11.3 N·m (100 in. lb.) into new holes or 7.3 N·m (65 in. lb.) into used holes in sequence shown. Note first screw is torqued a second time.

Reconnect Rectifier-Regulator

1. Install rectifier-regulator in blower housing, if removed previously, then connect rectifier-regulator ground lead with washer and silver screw through eyelet. If a grounding bracket is used, secure with lower mounting screw and washer, against outer side of rectifier-regulator.
2. Install B+ terminal/lead into center position of rectifier-regulator plug and connect plug to rectifier-regulator.

SMART-SPARK™ Module

On engines with SMART-SPARK™, reinstall SAM Module to blower housing or cylinder baffle. Do not overtighten retaining screws.

Install Electric Starter Motor

NOTE: If engine uses a side mount muffler on starter side, be sure to tie wires close to starter to avoid contact with hot exhaust parts.

1. Install starter motor using two screws. Some inertia-drive starters have a pinion cover and spacers on starter bolts.
2. Torque screws to 15.3 N·m (135 in. lb.).
3. On models with a solenoid shift starter, connect leads to solenoid.

Install Carburetor (Mechanical Governor)



⚠ WARNING

Explosive Fuel can cause fires and severe burns.
If a gaseous odor is detected, ventilate area and contact an authorized service technician.

LPG is extremely flammable and is heavier than air and tends to settle in low areas where a spark or flame could ignite gas. Do not start or operate this engine in a poorly ventilated area where leaking gas could accumulate and endanger safety of persons in area.

NG is extremely flammable, is lighter than air, and rises. Do not start or operate this engine in a poorly ventilated area where leaking gas could accumulate and endanger safety of persons in area.

To ensure personal safety, installation and repair of LPG/NG fuel supply systems must be performed only by qualified LPG/NG system technicians. Improperly installed and maintained LPG/NG equipment could cause fuel supply system or other components to malfunction, causing gas leaks.

Observe federal, state and local laws governing LPG/NG fuel, storage, and systems.

1. Install a new carburetor gasket. Make sure all holes align and are open.
2. Install carburetor, throttle linkage and governor lever as an assembly. If a plastic intake manifold is used attach ground lead to carburetor mounting screw.
3. Torque carburetor mounting screws or nuts to 6.2-7.3 N·m (55-65 in. lb.).

Install Carburetor and Electronic Governor

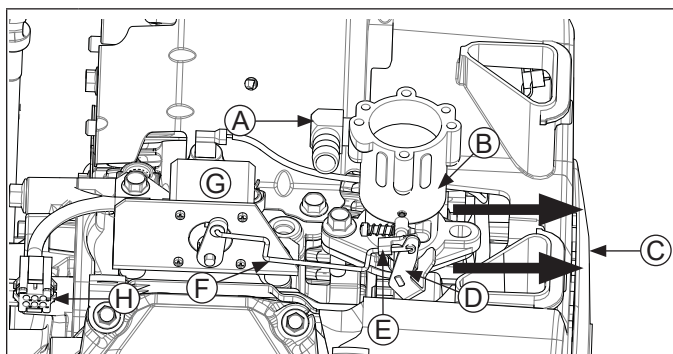

A	Carburetor Fitting	B	Carburetor
C	Flywheel Side	D	Carburetor Throttle Lever
E	Bushing	F	Throttle Linkage
G	Electronic Governor Assembly	H	Electronic Governor Connector

1. Install a new carburetor gasket. Make sure all holes align and are open.
2. Place carburetor in position on intake manifold/ carburetor gasket, then start screws. While holding carburetor towards flywheel side of engine, torque screws to 6.2-7.3 N·m (55-65 in. lb.).

3. Reconnect fuel hose to carburetor fitting and secure hose clamp.
4. Reconnect throttle linkage in carburetor throttle lever and secure with bushing.
5. Position electronic governor assembly on crankcase and start screws but do not tighten them.



6. Lightly hold throttle lever in idle position. Use a straight edge ruler and adjust governor assembly location to measure 2.54 cm (1 inch) from back of throttle linkage. Torque screws to 7.3 N·m (65 in. lb.).
7. Connect electronic governor to wiring harness.

Install LPG/NG Components

1. Install regulator bracket to crankcase with screws and torque to 22.6 N·m (200 in. lb.).
2. Install regulator to bracket with screws and torque to 24.4 N·m (216 in. lb.). Attach vacuum line and fuel lines to regulator.
3. Secure vaporizer to bracket (if equipped) with 2 screws. Torque 3/8 in. screw to 29.4 N·m (260 in. lb.) and 1/4 in. screw to 7.9 N·m (70 in. lb.).
4. Attach fuel lines from regulator to lock-off/filter and carburetor.

Reassembly

Control Bracket Components (Mechanical Governor)

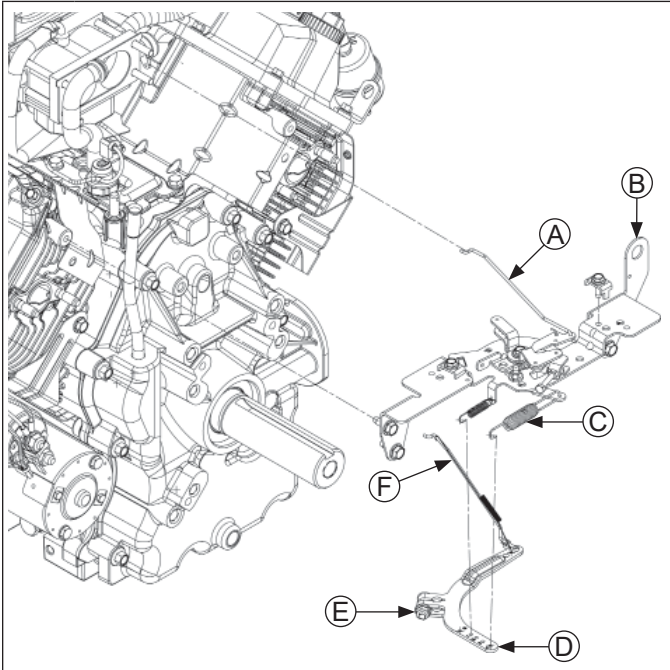

A	Choke Linkage	B	Control Bracket
C	Spring	D	Governor Lever
E	Nut	F	Throttle Linkage

Install External Governor Controls (Mechanical Governor)

1. Install governor lever onto governor cross shaft.
2. Make sure throttle linkage is connected to governor lever and throttle lever on carburetor.
3. Move governor lever toward carburetor as far as it will go (wide-open throttle) and hold in position.
4. Insert a nail into hole on cross shaft and rotate shaft counterclockwise as far as it will turn, then torque nut to 6.8 N·m (60 in. lb.).

Install Throttle & Choke Controls (Mechanical Governor)

1. Connect choke linkage to carburetor and choke actuator lever.
2. Mount main control bracket, and air cleaner support bracket (if used) to cylinder heads using four screws. Torque screws to 10.7 N·m (95 in. lb.) into new holes, or 7.3 N·m (65 in. lb.) into used holes.
3. Connect governor spring from main control bracket to appropriate hole in governor lever as indicated in applicable chart. Note that hole positions are counted from pivot point of governor lever.

Governor Lever Hole Position (6 mm)

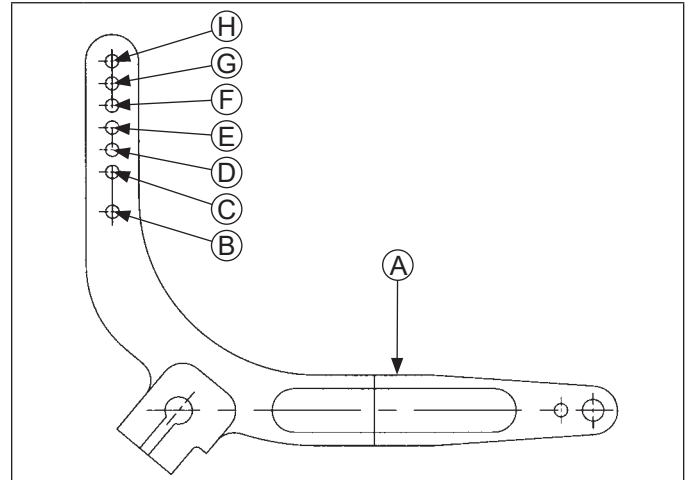

A	Governor Lever	B	Governed Idle Hole
C	Hole 1	D	Hole 2
E	Hole 3	F	Hole 4
G	Hole 5	H	Hole 6

6 mm Governor Lever and Hole Position/RPM Chart

High Idle RPM	Gov. Lever Hole No.	Governor Spring Color Code
3801-4000	5	Clear
3601-3800	4	Clear
3451-3600	3	Clear
3301-3450	2	Clear
3101-3300	4	Purple
2951-3100	3	Purple
2800-2950	2	Purple
3750*	3	Clear
3150*	3	Purple

*5% Regulation (others 10%)

Governor Lever Hole Position (8 mm)

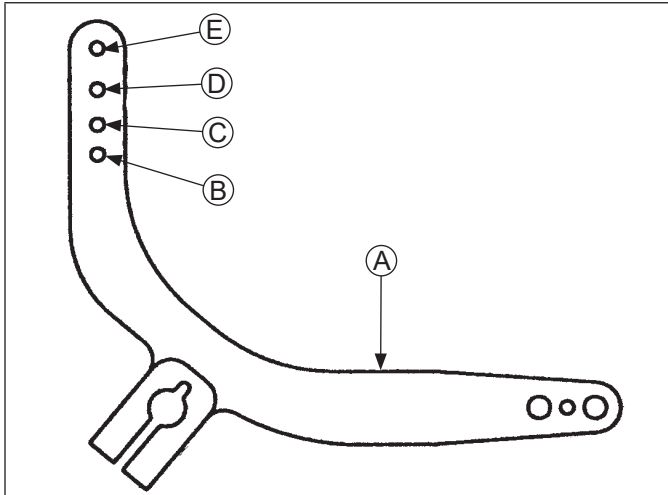

A	Governor Lever	B	Hole 1
C	Hole 2	D	Hole 3
E	Hole 4		

Install Oil Sentry™ (if equipped)

1. Apply pipe sealant with Teflon® (Loctite® PST® 592™ Thread Sealant or equivalent) to threads of Oil Sentry™ switch and install it into breather cover. Torque to 4.5 N·m (40 in. lb.).
2. Connect wire lead (green) to Oil Sentry™ terminal.

Install Control Panel (if equipped)

1. Install panel to blower housing.
2. Connect throttle control cable or shaft.
3. Connect choke control cable to control bracket.
4. Connect Oil Sentry™ indicator light wires.

8 mm Governor Lever and Hole Position/RPM Chart

High Idle RPM	Gov. Lever Hole No.	Governor Spring Color Code
3900-4000	4	Red
3825	3	Orange
3750-3800	3	Purple
3600-3700	3	Black
3500-3550	3	Red
3400-3450	2	Purple
3300-3350	2	Blue
3200-3250	1	Orange
3150	3	Black
3100	2	Clear
3000	1	Red
2900	1	Clear
3744*	2	Orange
3120*	1	Clear

*5% Regulation (others 10%)

Reassembly

Install Valve Covers

Torque Sequence

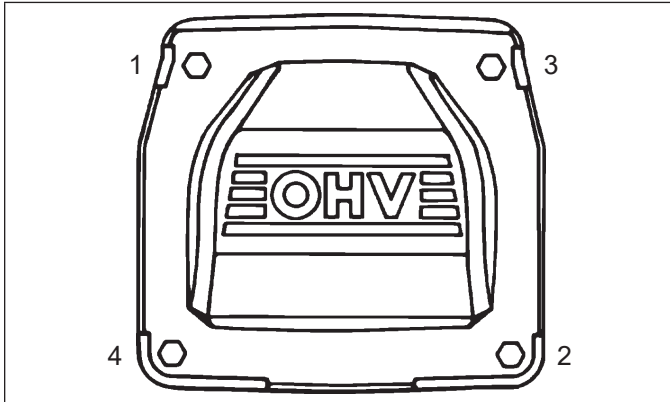

NOTE: Do not scrape old RTV sealant (if used) off sealing surface of cylinder head as this could cause damage and result in leaks. Use of gasket remover solvent (paint remover) is recommended.

Three valve cover designs have been used. First type used a gasket and RTV sealant between cover and sealing surface of cylinder head. Second type had a black O-ring installed in a groove on underside of cover and may have metal spacers in bolt holes. Latest design uses a yellow or brown O-ring, with bolt hole spacers molded in place. Tightening torque differs between gasket and O-ring style covers. Kits are available for converting to latest O-ring type covers. Differences are pointed out in following installation steps.

1. If using gasket or sealant type cover, prepare sealing surfaces of cylinder head and cover, refer to Tools and Aids for approved sealants. Always use fresh sealant. Using outdated sealant could result in leakage. With O-ring type covers, make sure sealing surfaces are clean.
2. Make sure there are no nicks or burrs on sealing surfaces.
3. For covers requiring RTV sealant, apply a 1.5 mm (1/16 in.) bead to sealing surface of both cylinder heads, install a new cover gasket on each, then apply a second bead of sealant on top surface of gaskets. For O-ring type covers, install a new O-ring in groove of each cover. Do not use gaskets or RTV sealant.
4. Locate cover with oil fill neck on same side as removed and install lifting strap in original position. With O-ring type covers, position cover on cylinder head. If loose spacers were used, insert a spacer in each screw hole. On both types, install four screws in each cover and finger tighten.
5. Torque valve cover fasteners to proper specification using sequence shown.

Torque Specifications-Covers

Gasket/RTV	3.4 N·m (30 in. lb.)
Black O-ring w/shoulder screws w/screws and spacers	5.6 N·m (50 in. lb.) 9.9 N·m (88 in. lb.)
Yellow or Brown O-ring w/integral spacers	9.0 N·m (80 in. lb.)

Install Air Cleaner Assembly

NOTE: Route fuel line in contour to avoid restriction.

1. Attach rubber breather hose to breather cover. Connect fuel inlet line to carburetor and secure with a clamp.
2. Position a new gasket and air cleaner base while carefully pulling loose end of rubber breather hose through base until properly seated (collars sealed against each side of base).
3. Secure air cleaner base and bracket using screws. Position bracket with hole toward breather hose. Be careful not to drop screws into carburetor. If a rear air cleaner bracket is used, install two M5 screws through rear of base. Torque three M6 screws to 6.2-7.3 N·m (55-65 in. lb.) and two rear M5 mounting screws (when applicable) to 4.0 N·m (35 in. lb.).
4. Install breather hose in hole of bracket.
5. Install air cleaner components, refer to Air Cleaner/ Intake.

Install Muffler

1. Install port liners (if equipped). Install muffler and attaching hardware to muffler bracket. Torque screws to 9.9 N·m (88 in. lb.).
2. Install nuts to exhaust studs. Torque nuts to 24.4 N·m (216 in. lb.).

Install Oil Cooler (if equipped)

Oil cooler can now be installed to engine. Two different styles are used.

1. Depending on style used, reverse removal procedure from Disassembly.
2. Secure cooler or adapter to oil pan with oil filter nipple. Torque oil filter nipple to 27 N·m (20 ft. lb.).

Install Oil Filter and Fill Crankcase with Oil

NOTE: Make sure both oil drain plugs are installed and torqued to specifications to prevent oil leakage.

1. Install oil drain plug(s). Torque plug(s) to 13.6 N·m (10 ft. lb.). If oil drain valve is used, make sure valve body is closed and cap is on.
2. Place new filter in shallow pan with open end up. Fill with new oil until oil reaches bottom of threads. Allow 2 minutes for oil to be absorbed by filter material.
3. Apply a thin film of clean oil to rubber gasket on oil filter.
4. Refer to instructions on oil filter for proper installation.
5. Fill crankcase with new oil. Level should be at top of indicator on dipstick.
6. Reinstall oil fill cap/dipstick and tighten securely.

Connect Spark Plug Leads

Connect leads to spark plugs.

Prepare Engine for Operation

Engine is now completely reassembled. Before starting or operating engine, be sure to follow these steps.

1. Make sure all hardware is tightened securely.
2. Make sure oil drain plugs, Oil Sentry™ pressure switch, and a new oil filter are installed.
3. Adjust carburetor, idle fuel needle, or idle speed adjusting screw as necessary.

Testing Engine

It is recommended engine be operated on a test stand or bench prior to installation in piece of equipment.

1. Set engine up on a test stand. Install an oil pressure gauge. Start engine and check to be certain oil pressure (20 psi or more) is present. Run engine at idle for 2-3 minutes, then 5-6 minutes more between idle and midrange. Adjust carburetor mixture settings as necessary (as available).
2. Adjust idle speed screw and high-speed stop as necessary. Make sure maximum engine speed does not exceed 3750 RPM (no load).



1P24 690 30



8 85612 10336 9