

Command Pro EFI

ECH630-ECH749, CH735, CH26, CH745

Service Manual

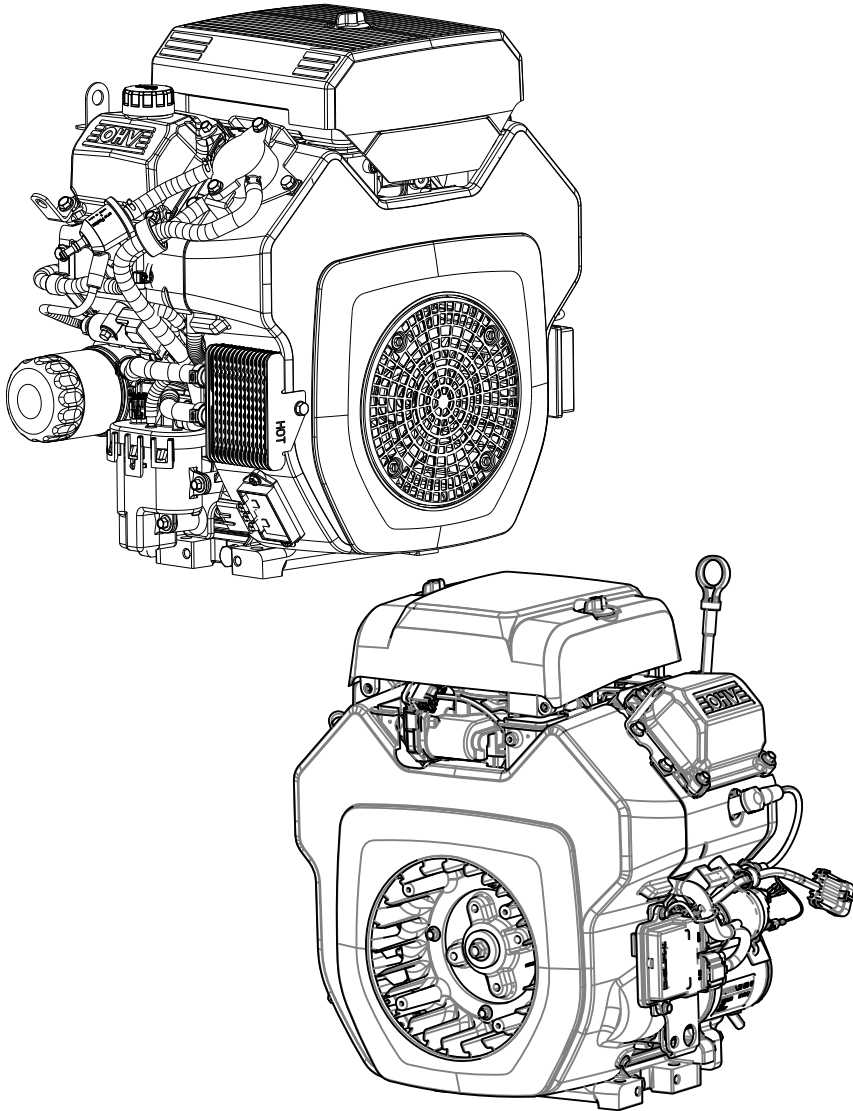

Kohler Engines
is now Rehlko.

2	Safety
3	Maintenance
5	Specifications
23	Tools and Aids
26	Troubleshooting
31	Air Cleaner/Intake
32	Electronic Fuel Injection (EFI) System-Electronic Throttle Body (ETB) ECH
65	Electronic Fuel Injection (EFI) System-ECH WITH OXYGEN SENSOR
94	Electronic Fuel Injection (EFI) System-ECH WITHOUT OXYGEN SENSOR
115	Electronic Fuel Injection (EFI) System-Bosch
148	Lubrication System
150	Electrical System
157	Starter System
161	Disassembly/Inspection and Service
182	Reassembly

IMPORTANT: Read all safety precautions and instructions carefully before operating equipment. Refer to operating instruction of equipment that this engine powers.

Ensure engine is stopped and level before performing any maintenance or service.

Safety

SAFETY PRECAUTIONS

⚠ WARNING: A hazard that could result in death, serious injury, or substantial property damage.

⚠ CAUTION: A hazard that could result in minor personal injury or property damage.

NOTE: is used to notify people of important installation, operation, or maintenance information.

	⚠ WARNING
	Explosive Fuel can cause fires and severe burns. Do not fill fuel tank while engine is hot or running.
Gasoline is extremely flammable and its vapors can explode if ignited. Store gasoline only in approved containers, in well ventilated, unoccupied buildings, away from sparks or flames. Spilled fuel could ignite if it comes in contact with hot parts or sparks from ignition. Never use gasoline as a cleaning agent.	

	⚠ WARNING
	Rotating Parts can cause severe injury. Stay away while engine is in operation.
Keep hands, feet, hair, and clothing away from all moving parts to prevent injury. Never operate engine with covers, shrouds, or guards removed.	

	⚠ WARNING
	Carbon Monoxide can cause severe nausea, fainting or death. Avoid inhaling exhaust fumes. Never run engine indoors or in enclosed spaces.
Engine exhaust gases contain poisonous carbon monoxide. Carbon monoxide is odorless, colorless, and can cause death if inhaled.	

	⚠ WARNING
	Accidental Starts can cause severe injury or death. Disconnect and ground spark plug lead(s) before servicing.
Before working on engine or equipment, disable engine as follows: 1) Disconnect spark plug lead(s). 2) Disconnect negative (-) battery cable from battery.	

	⚠ WARNING
	Hot Parts can cause severe burns. Do not touch engine while operating or just after stopping.
Never operate engine with heat shields or guards removed.	

	⚠ WARNING
	Cleaning Solvents can cause severe injury or death. Use only in well ventilated areas away from ignition sources.
Carburetor cleaners and solvents are extremely flammable. Follow cleaner manufacturer's warnings and instructions on its proper and safe use. Never use gasoline as a cleaning agent.	

	⚠ CAUTION
	Electrical Shock can cause injury. Do not touch wires while engine is running.

	⚠ CAUTION
	Damaging Crankshaft and Flywheel can cause personal injury.
Using improper procedures can lead to broken fragments. Broken fragments could be thrown from engine. Always observe and use precautions and procedures when installing flywheel.	

	⚠ WARNING
	High Pressure Fluids can puncture skin and cause severe injury or death. Do not work on fuel system without proper training or safety equipment.
Fluid puncture injuries are highly toxic and hazardous. If an injury occurs, seek immediate medical attention.	

	⚠ WARNING
	Explosive Fuel can cause fires and severe burns. Fuel system ALWAYS remains under HIGH PRESSURE.
Wrap a shop towel completely around fuel pump module connector. Press release button(s) and slowly pull connector away from fuel pump module allowing shop towel to absorb any residual fuel in high pressure fuel line. Any spilled fuel must be completely wiped up immediately.	

MAINTENANCE INSTRUCTIONS

	⚠ WARNING	Before working on engine or equipment, disable engine as follows: 1) Disconnect spark plug lead(s). 2) Disconnect negative (-) battery cable from battery.
	Accidental Starts can cause severe injury or death. Disconnect and ground spark plug lead(s) before servicing.	

Normal maintenance, replacement or repair of emission control devices and systems may be performed by any repair establishment or individual; however, warranty repairs must be performed by a Rehlko authorized dealer.

MAINTENANCE SCHEDULE

Every 25 Hours or Annually¹

<ul style="list-style-type: none"> Service/replace low-profile precleaner (if equipped). 	Air Cleaner/Intake
---------------------------------------------------------------------------------------------------------	--------------------

Every 100 Hours or Annually¹

<ul style="list-style-type: none"> Change oil. 	Lubrication System
<ul style="list-style-type: none"> Replace low-profile air cleaner element. 	Air Cleaner/Intake
<ul style="list-style-type: none"> Remove and clean shrouds and cooling areas. Inspect for any debris visible through flywheel cooling holes (if equipped) and clean as necessary. 	Air Cleaner/Intake
<ul style="list-style-type: none"> Check oil cooler fins, clean as necessary (if equipped). 	Lubrication System

Every 150 Hours

<ul style="list-style-type: none"> Check heavy-duty filter minder. 	Air Cleaner/Intake
<ul style="list-style-type: none"> Inspect heavy-duty air filter paper element and inlet screen area. 	Air Cleaner/Intake

Every 200 Hours¹

<ul style="list-style-type: none"> Replace unique Electronic Fuel Injection (EFI) fuel filter.

Every 200 Hours

<ul style="list-style-type: none"> Change oil filter. 	Lubrication System
----------------------------------------------------------------------	--------------------

Every 300 Hours¹

<ul style="list-style-type: none"> Replace heavy-duty air cleaner element and check inner element. 	Air Cleaner/Intake
-------------------------------------------------------------------------------------------------------------------	--------------------

Every 300 Hours²

<ul style="list-style-type: none"> Change oil and filter (Xtended Life PRO 10W-50 oil and Xtended Life PRO filter only). 	Lubrication System
-----------------------------------------------------------------------------------------------------------------------------------------	--------------------

Every 500 Hours or Annually¹

<ul style="list-style-type: none"> Replace spark plugs and set gap. 	Electrical System
------------------------------------------------------------------------------------	-------------------

Every 600 Hours¹

<ul style="list-style-type: none"> Replace heavy-duty air cleaner inner element. 	Air Cleaner/Intake
-------------------------------------------------------------------------------------------------	--------------------

¹Perform these procedures more frequently under severe, dusty, dirty conditions.

²Option only if using Xtended Life PRO oil and PRO filter.

REPAIRS/SERVICE PARTS

Rehlko genuine service parts can be purchased from Rehlko authorized dealers. To find a local Rehlko authorized dealer visit Engines.rehlko.com or call 1-800-544-2444 (U.S. and Canada).

Maintenance

OIL RECOMMENDATIONS

All-season Xtended Life PRO 10W-50 Synthetic Oil is the ideal oil for Rehlko engines. It is specifically formulated to extend the oil and oil filter change interval to 300 Hours when paired with a Xtended Life PRO Oil Filter.

300-Hour oil and oil filter change intervals are exclusive to and only authorized on Rehlko engines that utilize both the Xtended Life PRO 10W-50 Synthetic Oil and Xtended Life PRO Oil Filter. Alternative engine oils and oil filters may be used with Rehlko engines but require 100-Hour oil and 200-Hour oil filter change intervals for proper maintenance. Oil must be API (American Petroleum Institute) service class SJ or higher. Select viscosity based on air temperature at time of operation as shown below.

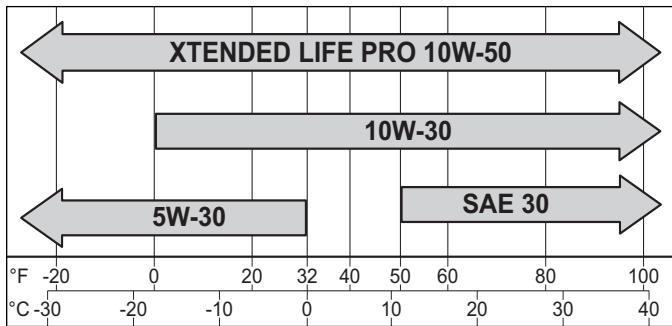

STORAGE

If engine will be out of service for 2 months or more follow procedure below.

1. Add Xtended Life PRO Series fuel treatment or equivalent to fuel tank. Run engine 2-3 minutes to get stabilized fuel into fuel system (failures due to untreated fuel are not warrantable).
2. Change oil while engine is still warm from operation (Not required if using Xtended Life PRO 10W-50 full-synthetic oil). Remove spark plug(s) and pour about 1 oz. of engine oil into cylinder(s). Replace spark plug(s) and crank engine slowly to distribute oil.
3. Disconnect negative (-) battery cable.
4. Store engine in a clean, dry place.

FUEL RECOMMENDATIONS

	WARNING
	Explosive Fuel can cause fires and severe burns. Do not fill fuel tank while engine is hot or running.
Gasoline is extremely flammable and its vapors can explode if ignited. Store gasoline only in approved containers, in well ventilated, unoccupied buildings, away from sparks or flames. Spilled fuel could ignite if it comes in contact with hot parts or sparks from ignition. Never use gasoline as a cleaning agent.	

NOTE: E15, E20 and E85 are NOT approved and should NOT be used; effects of old, stale or contaminated fuel are not warrantable.

Fuel must meet these requirements:

- Clean, fresh, unleaded gasoline.
- Octane rating of 87 (R+M)/2 or higher.
- Research Octane Number (RON) 90 octane minimum.
- Gasoline up to 10% ethyl alcohol, 90% unleaded is acceptable.
- Methyl Tertiary Butyl Ether (MTBE) and unleaded gasoline blend (max 15% MTBE by volume) are approved.
- Do not add oil to gasoline.
- Do not overfill fuel tank.
- Do not use gasoline older than 30 days.

Engine Dimensions with Heavy-Duty Air Cleaner-Flywheel Side

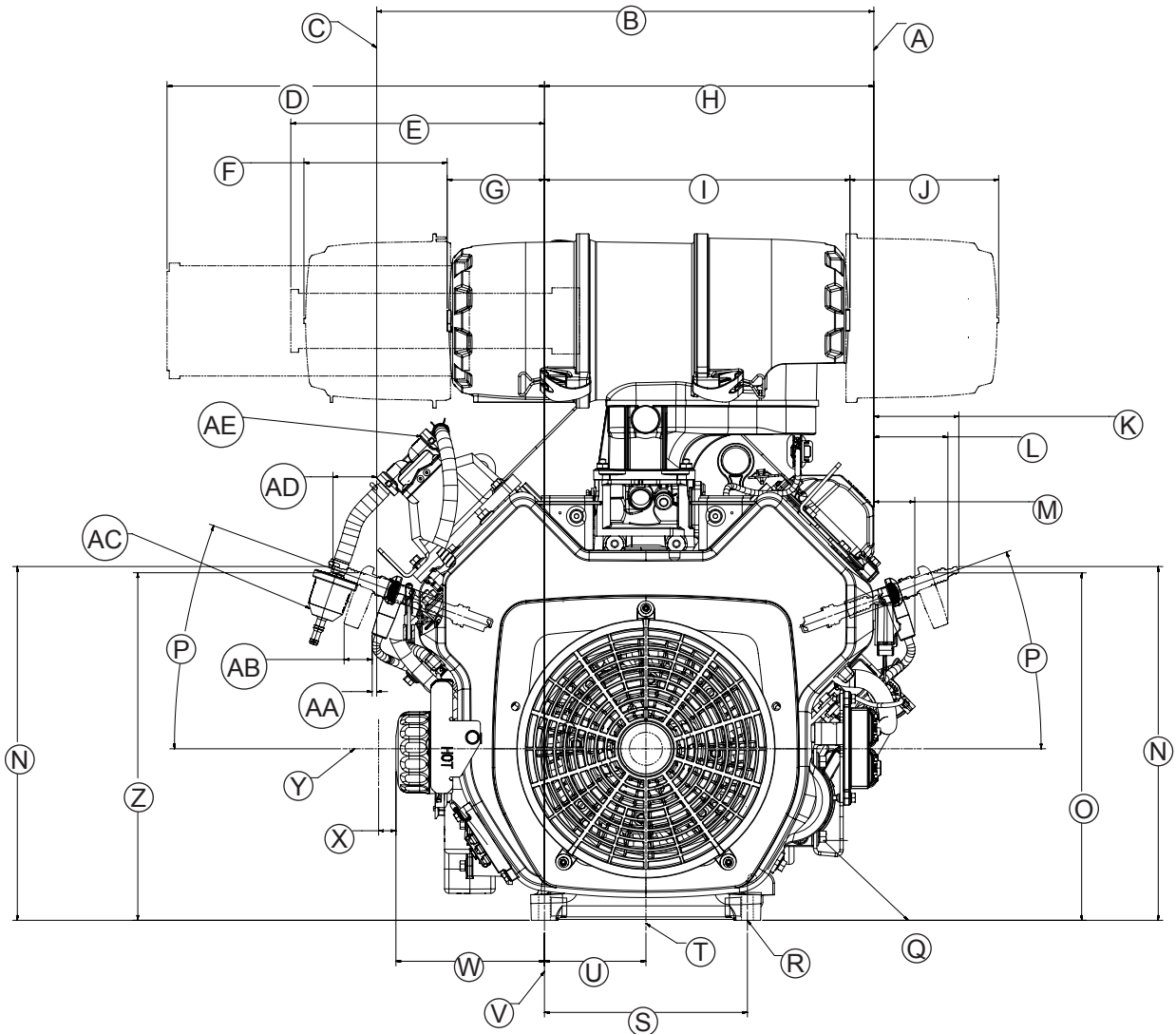

A	Valve Cover	B	451.16 mm (17.762 in.)	C	Fuel Pump	D	342.52 mm (13.485 in.)
E	230.20 mm (9.063 in.)	F	130.0 mm (5.118 in.)	G	88.28 mm (3.475 in.)	H	298.93 mm (11.769 in.)
I	277.22 mm (10.914 in.)	J	135.0 mm (5.315 in.)	K	77.17 mm (3.038 in.) Spark Plug Removal	L	67.19 mm (2.645 in.) Spark Plug Boot Removal
M	37.15 mm (1.463 in.) Spark Plug Boot	N	320.89 mm (12.633 in.) Spark Plug Removal	O	315.14 mm (12.407 in.) Spark Plug Boot Removal	P	20°
Q	Engine Mounting Surface	R	4X Ø 10.3 mm (0.406 in.)	S	184.20 mm (7.252 in.)	T	Engine Center Line
U	92.10 mm (3.626 in.)	V	Center Line Mounting Hole "A"	W	134.80 mm (5.307 in.)	X	15.70 mm (0.618 in.) Oil Filter Removal
Y	Crankshaft Center Line	Z	315.25 mm (12.412 in.) Spark Plug Boot Removal	AA	4.12 mm (0.182 in.) Spark Plug Boot	AB	25.46 mm (1.002 in.) Spark Plug Boot Removal
AC	Fuel Filter	AD	39.66 mm (1.562 in.) Spark Plug Removal	AE	Fuel Pump		

Specifications

Engine Dimensions with Heavy-Duty Air Cleaner-Oil Filter Side

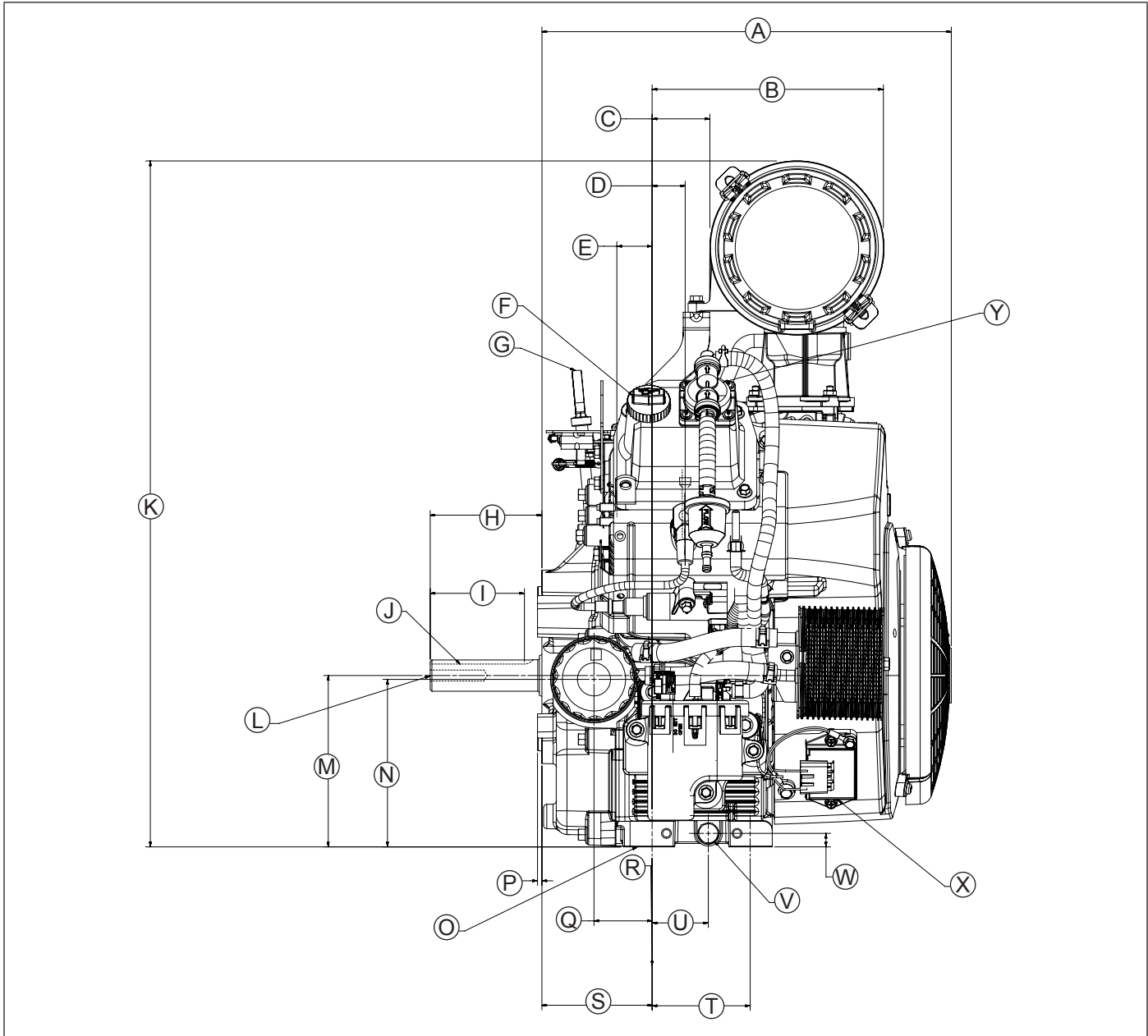

A	371.44 mm (14.624 in.)	B	209.88 mm (8.263 in.)	C	52.43 mm (2.064 in.)	D	30.0 mm (1.181 in.) Spark Plug Center Line
E	32.00 mm (1.260 in.) Exhaust Port #2	F	Oil Fill	G	Dipstick	H	101.38 mm (3.992 in.)
I	85.50 mm (3.366 in.) Keyway	J	1/4 in. Square Keyway	K	622.70 mm (24.516 in.)	L	7/16-20 UNF-2B in. 38.10 mm (1.5 in.) Deep
M	155.58 mm (6.125 in.)	N	152.08 mm (5.987 in.) Oil Filter	O	Engine Mounting Surface	P	4.00 mm (0.157 in.) Pilot
Q	52.75 mm (2.077 in.) Oil Filter	R	Center Line Mounting Hole "A"	S	100.0 mm (3.937 in.)	T	89.0 mm (3.504 in.)
U	51.0 mm (2.008 in.)	V	Oil Drain Plug 3/8 in. NPT	W	12.28 mm (0.483 in.)	X	Rectifier-Regulator
Y	Fuel Pump						

Engine Dimensions with Heavy-Duty Air Cleaner-PTO Side

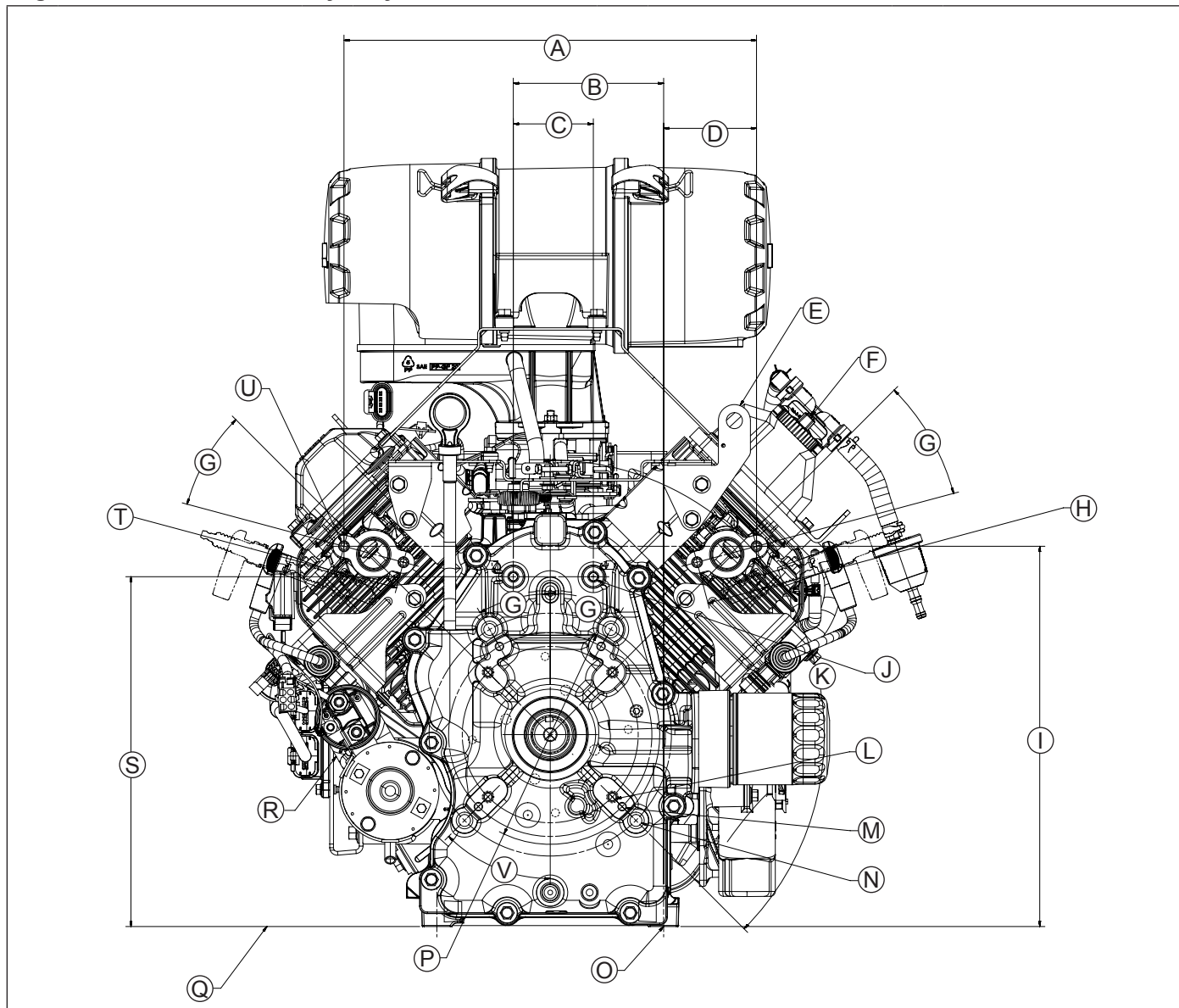

A	335.04 mm (13.19 in.)	B	122.10 mm (4.807 in.)	C	65.0 mm (2.559 in.) Muffler Mounting	D	75.42 mm (2.969 in.)
E	Lift Strap	F	Oil Fill Location	G	30°	H	50.00 mm (1.969 in.) Exhaust Port #2
I	2 X 306.24 mm (12.136 in.)	J	2 X M8 X 1.25 20.5 mm (0.807 in.) Deep	K	135°	L	5/16-24 UNC-2B in. 17 mm (0.669 in.) Deep 127 mm (5.0 in.) B.C.
M	3/8-16 UNC-2B in. 21 mm (0.827 in.) Deep 165.1 mm (6.5 in.) B.C.	N	7/16-14 UNC-2B in. 21 mm (0.827 in.) Deep 196.8 mm (7.75 in.) B.C.	O	Center Line Mounting Hole "A"	P	177.8 mm (7.0 in.) Pilot Diameter
Q	Engine Mounting Surface	R	Solenoid Shift Starter	S	283.58 mm (11.164 in.) Muffler Mounting	T	50.00 mm (1.969 in.) Exhaust Port #1
U	M8 X 1.25 4 Studs	V	45°				

Specifications

Engine Dimensions with Heavy-Duty Air Cleaner-Starter Side

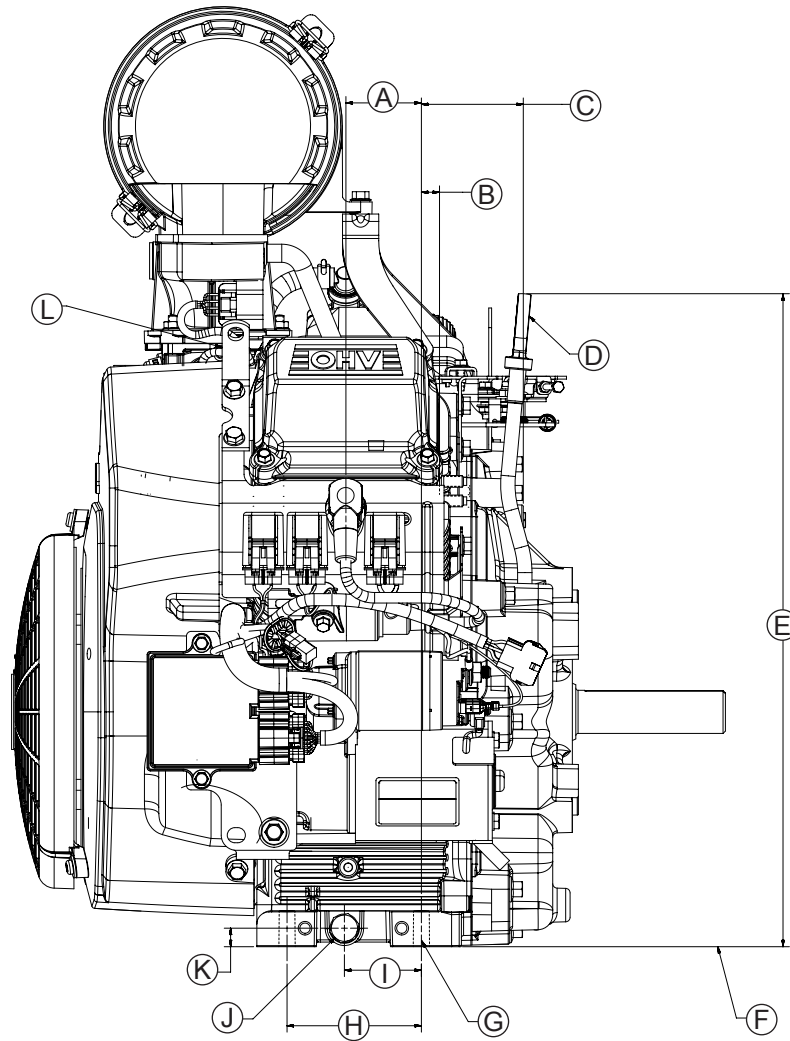

A	50.0 mm (1.969 in.) Center Line Spark Plug	B	12.0 mm (0.472 in.) Exhaust Port #1	C	67.50 mm (2.657 in.) Muffler Mounting Bosses	D	Dipstick
E	432.58 mm (17.031 in.)	F	Engine Mounting Surface	G	Center Line Mounting Hole "A"	H	89.0 mm (3.504 in.)
I	51.0 mm (2.008 in.)	J	Oil Drain Plug 3/8 in.	K	12.28 mm (0.483 in.)	L	Lift Strap

Engine Dimensions with Low-Profile Air Cleaner-Flywheel Side

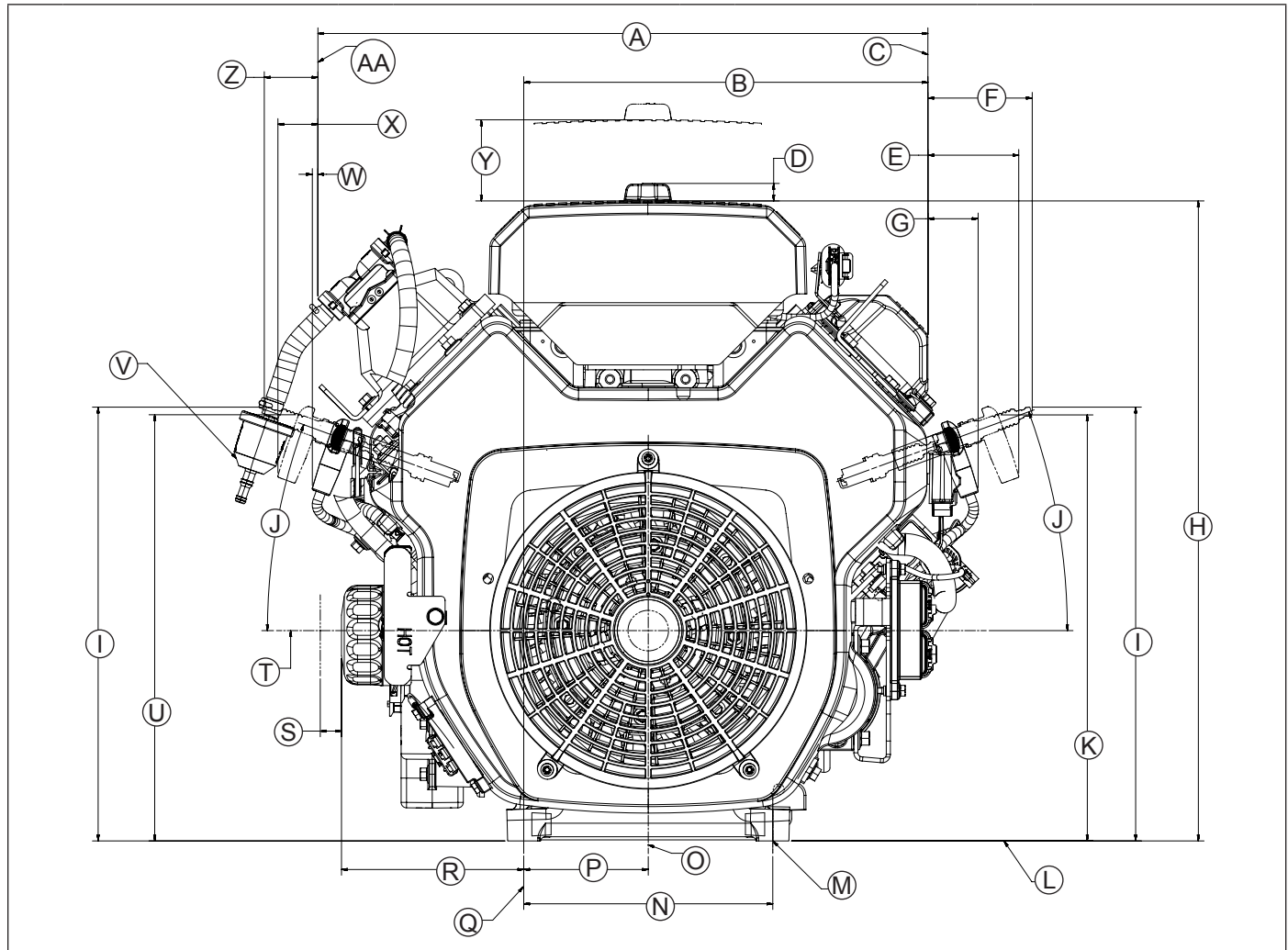

A	451.16 mm (17.762 in.)	B	298.93 mm (11.769 in.)	C	Valve Cover	D	12.95 mm (0.510 in.)
E	67.19 mm (2.645 in.) Spark Plug Boot Removal	F	77.17 mm (3.038 in.) Spark Plug Removal	G	37.15 mm (1.463 in.) Spark Plug Boot	H	473.43 mm (18.639 in.)
I	320.89 mm (3.038 in.) Spark Plug Removal	J	20°	K	315.14 mm (12.407 in.) Spark Plug Boot Removal	L	Engine Mounting Surface
M	4X Ø 10.3 mm (0.406 in.)	N	184.20 mm (7.252 in.)	O	Engine Center Line	P	92.10 mm (3.628 in.)
Q	Center Line Mounting Hole "A"	R	134.80 mm (5.307 in.)	S	15.70 mm (0.618 in.) Oil Filter Removal	T	Crankshaft Center Line
U	315.25 mm (12.412 in.) Spark Plug Boot Removal	V	Fuel Filter	W	4.12 mm (0.162 in.) Spark Plug Boot	X	29.58 mm (1.165 in.) Spark Plug Boot Removal
Y	60.0 mm (2.362 in.) Air Cleaner Cover Removal	Z	39.66 mm (1.562 in.) Spark Plug Removal	AA	Fuel Pump		

Specifications

Engine Dimensions with Low-Profile Air Cleaner-Oil Filter Side

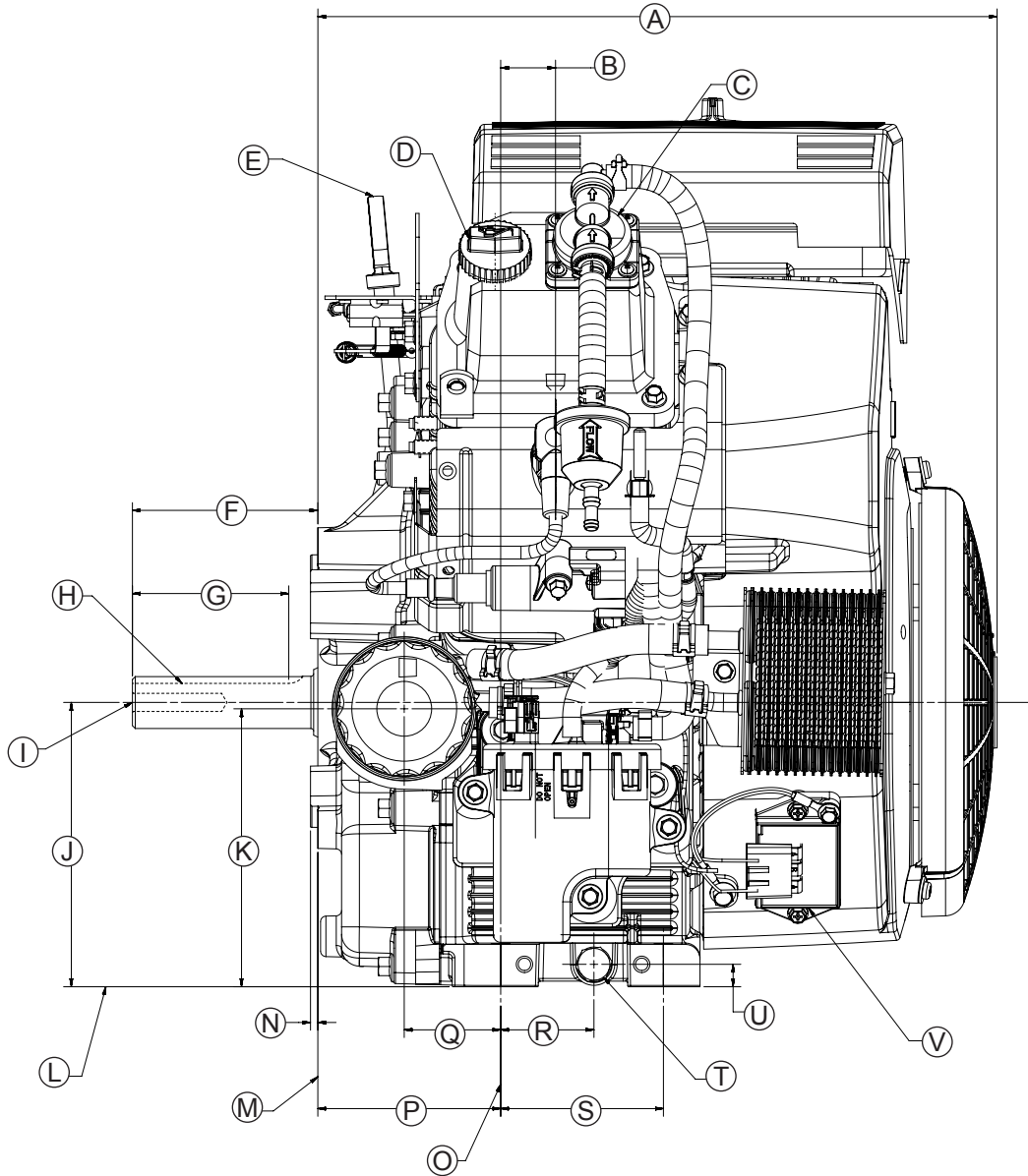

A	371.44 mm (14.624 in.)	B	30.0 mm (1.181 in.) Spark Plug Center Line	C	Fuel Pump	D	Oil Fill
E	Dipstick	F	101.38 mm (3.992 in.)	G	85.50 mm (3.366 in.) Keyway	H	1/4 in. Square Keyway
I	7/16-20 UNF 2B in. 38.10 mm (1.5 in.) Deep	J	155.58 mm (6.125 in.)	K	152.08 mm (5.987 in.) Oil Filter	L	Engine Mounting Surface
M	Mounting Surface	N	4.00 mm (0.157 in.) Pilot	O	Center Line Mounting Hole "A"	P	100.0 mm (3.937 in.)
Q	52.75 mm (2.077 in.) Oil Filter	R	51.0 mm (2.008 in.)	S	89.0 mm (3.504 in.)	T	Oil Drain Plug 3/8 in. NPT
U	12.28 mm (0.483 in.)	V	Rectifier-Regulator				

Engine Dimensions with Low-Profile Air Cleaner-PTO Side

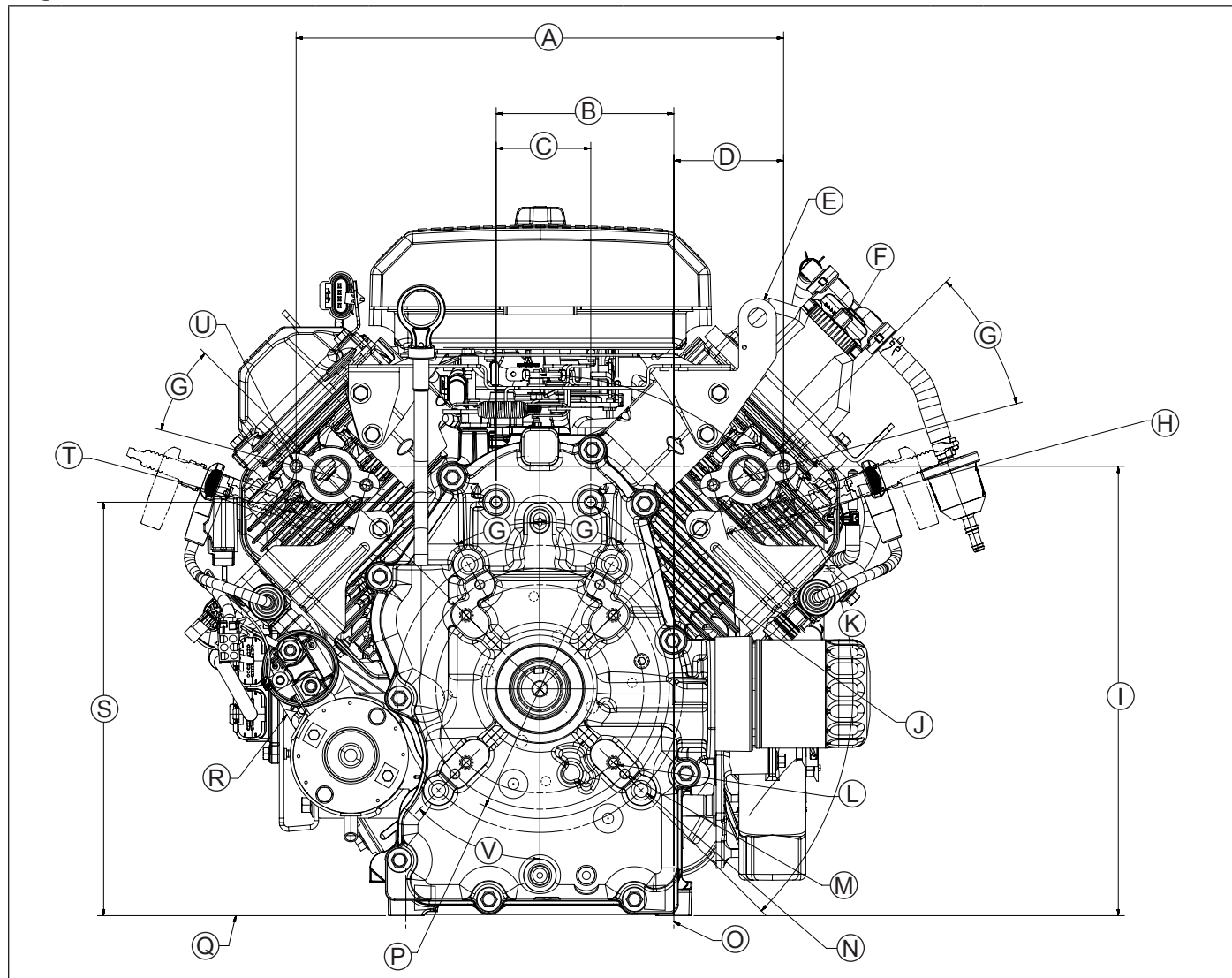

A	335.04 mm (13.19 in.)	B	122.10 mm (4.807 in.)	C	65.0 mm (2.559 in.) Muffler Mounting	D	75.42 mm (2.969 in.)
E	Lift Strap	F	Oil Fill Location	G	30°	H	50.00 mm (1.969 in.) Exhaust Port #2
I	2 X 308.24 mm (12.136 in.)	J	2 X M8 X 1.25 20.5 mm (0.807 in.) Deep	K	135°	L	5/16-24 UNC-2B in. 17 mm (0.669 in.) Deep 127 mm (5.0 in.) B.C.
M	3/8-16 UNC-2B in. 21 mm (0.827 in.) Deep 165.1 mm (6.5 in.) B.C.	N	7/16-14 UNC-2B in. 21 mm (0.827 in.) Deep 196.8 mm (7.75 in.) B.C.	O	Center Line Mounting Hole "A"	P	177.8 mm (7.0 in.) Pilot Diameter
Q	Engine Mounting Surface	R	Solenoid Shift Starter	S	283.58 mm (11.164 in.) Muffler Mounting	T	50.00 mm (1.969 in.) Exhaust Port #1
U	M8 X 1.25 4 Studs	V	45°				

Specifications

Engine Dimensions with Low-Profile Air Cleaner-Starter Side

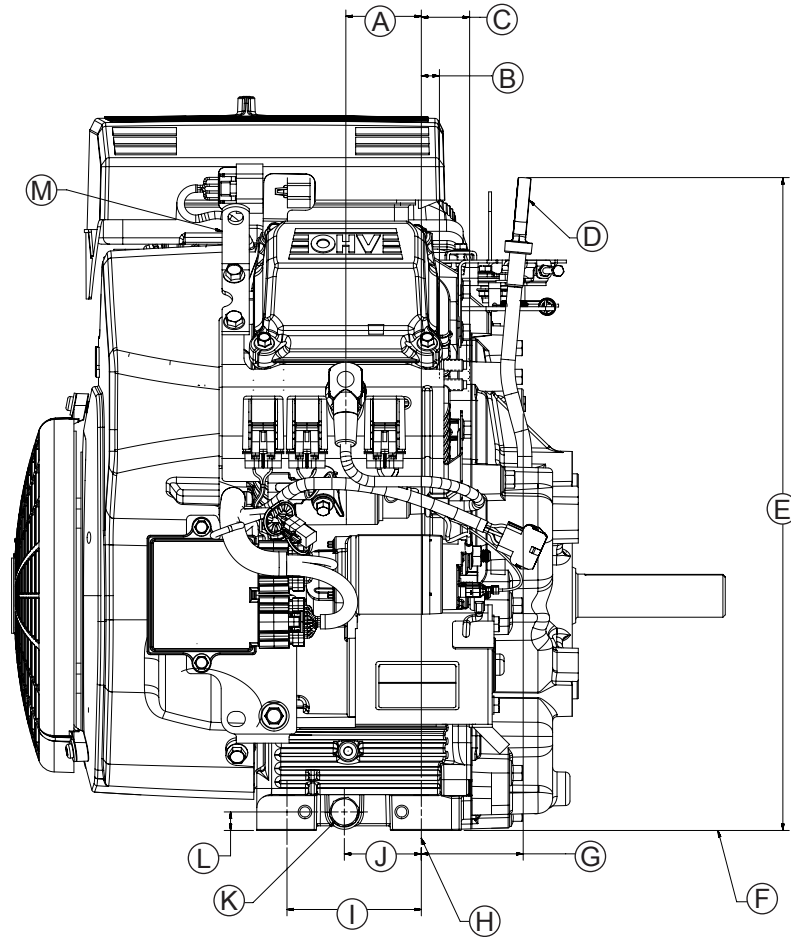

A	50.0 mm (1.969 in.) Center Line Spark Plug	B	12.0 mm (0.472 in.) Exhaust Port #1	C	32.0 mm (1.260 in.) Exhaust Port #2	D	Dipstick
E	432.58 mm (17.031 in.)	F	Engine Mounting Surface	G	67.50 mm (2.657 in.) Muffler Mounting Bosses	H	Center Line Mounting Hole "A"
I	89.0 mm (3.504 in.)	J	51.0 mm (2.008 in.)	K	Oil Drain Plug 3/8 in. NPT	L	12.28 mm (0.483 in.)
M	Lift Strap						

ENGINE IDENTIFICATION NUMBERS

Rehiko engine identification numbers (model, specification and serial) should be referenced for efficient repair, ordering correct parts, and engine replacement.

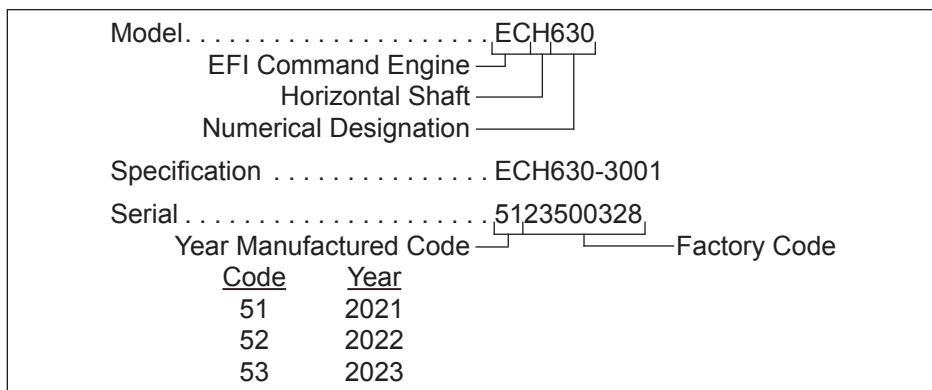

GENERAL SPECIFICATIONS ^{3,6}	ECH630-ECH680	ECH730-ECH749	CH26	CH735	CH745
Bore	80 mm (3.15 in.)	83 mm (3.27 in.)	83 mm (3.27 in.)		
Stroke	69 mm (2.72 in.)		67 mm (2.64 in.)		
Displacement	694 cc (42.4 cu. in.)	747 cc (45.6 cu. in.)	725 cc (44 cu. in.)		
Oil Capacity (refill)	1.9 L (2.0 U.S. qt.)				
Maximum Angle of Operation (@ full oil level) ⁴	25°				

TORQUE SPECIFICATIONS ^{3,5}	ECH630-ECH680	ECH730-ECH749	CH26	CH735	CH745
Blower Housing					
Into cored aluminum hole or weld nut M5	6.2 N·m (55 in. lb.) into new holes 4.0 N·m (35 in. lb.) into used holes				
M6	10.7 N·m (95 in. lb.) into new holes 7.3 N·m (65 in. lb.) into used holes				
Into extruded hole in sheet metal M5	2.8 N·m (25 in. lb.) into new holes 2.3 N·m (20 in. lb.) into used holes		6.2 N·m (55 in. lb.) into new holes 4.0 N·m (35 in. lb.) into used holes		
M6	2.8 N·m (25 in. lb.) into new holes 2.3 N·m (20 in. lb.) into used holes		10.7 N·m (95 in. lb.) into new holes 7.3 N·m (65 in. lb.) into used holes		

Closure Plate					
Fastener	25.6 N·m (227 in. lb.)		24.4 N·m (216 in. lb.)		

Connecting Rod					
Cap Fastener (torque in increments)					
8 mm straight shank			22.7 N·m (200 in. lb.)		
8 mm step-down			14.7 N·m (130 in. lb.)		
6 mm straight shank					
Black Coating	11.6 N·m (103 in. lb.)		11.3 N·m (100 in. lb.)		
Gray Metallic Coating	13.6 N·m (120 in. lb.)		13.6 N·m (120 in. lb.)		

³ Values are in Metric units. Values in parentheses are English equivalents.

⁴ Exceeding maximum angle of operation may cause engine damage from insufficient lubrication.

⁵ Lubricate threads with engine oil prior to assembly.

⁶ Any and all horsepower (hp) references by Rehiko are Certified Power Ratings and per SAE J1940 & J1995 hp standards. Details on Certified Power Ratings can be found at Engines.rehiko.com.

Specifications

TORQUE SPECIFICATIONS^{3,5}

ECH630-ECH680 ECH730-ECH749

CH26

CH735

CH745

Crankcase

Breather Cover Fastener	11.3 N·m (100 in. lb.) into new holes 7.3 N·m (65 in. lb.) into used holes	
Engine Temperature Sensor (into breather cover)	7.3 N·m (65 in. lb.)	
Oil Sentry TM (into breather cover)	4.5 N·m (40 in. lb.)	
Oil Drain Plug	13.6 N·m (10 ft. lb.)	

Cylinder Head

Hex Flange Nut (torque in 2 increments)	first to 16.9 N·m (150 in. lb.) finally to 33.9 N·m (300 in. lb.)	
Head Bolt (torque in 2 increments)	first to 22.6 N·m (200 in. lb.) finally to 41.8 N·m (370 in. lb.)	
Rocker Arm Screw Black Screw (M6x1.0x34) Silver Screw (M6x1.0x45)	18.1 N·m (160 in. lb.) 11.9 N·m (105 in. lb.)	

ETB Cover (LPAC)

Fastener	5.6 N·m (50 in. lb.)	
----------	----------------------	--

Fan/Flywheel

Fan Fastener	9.9 N·m (88 in. lb.)	
Flywheel Retaining Screw	71.6 N·m (52.8 ft. lb.)	66.4 N·m (49 ft. lb.)
Metal Debris Screen Fastener (to flywheel)	9.9 N·m (88 in. lb.)	
Plastic Debris Screen Fastener (to fan)	4.0 N·m (35 in. lb.)	

Fuel Pump

Module Baffle Fastener	11.9 N·m (105 in. lb.)	
Module Fastener	9.2 N·m (81 in. lb.)	
Pulse Pump Bracket Fastener	2.1 N·m (25 in. lb.)	
Pulse Pump Fastener to Bracket	7.3 N·m (68 in. lb.) into new holes 6.2 N·m (55 in. lb.) into used holes	

Governor (if equipped)

Lever Nut	7.1 N·m (63 in. lb.)	6.8 N·m (60 in. lb.)
Speed Control Assembly Assembled to Cylinder Heads Assembled to Blower Housing	10.7 N·m (95 in. lb.) 2.8 N·m (25 in. lb.)	

Ignition

Spark Plug	27 N·m (20 ft. lb.)	
Coil Fastener	10.2 N·m (90 in. lb.)	
Ignition Module Fastener Torque	4.0-6.2 N·m (35-55 in. lb.)	
Electronic Control Unit Screw	6.2 N·m (55 in. lb.)	
Rectifier-Regulator Ground Strap/ Ground Lead Fastener (into backing plate) (Standard Charging System)	2.8 N·m (25 in. lb.) into new holes 2.3 N·m (20 in. lb.) into used holes	
Rectifier-Regulator Ground Lead Fastener to Ground Lug/Backing Plate (Standard Charging System)	5.6 N·m (50 in. lb.) into new holes 4.0 N·m (35 in. lb.) into used holes	

³ Values are in Metric units. Values in parentheses are English equivalents.

⁵ Lubricate threads with engine oil prior to assembly.

TORQUE SPECIFICATIONS^{3,5}
ECH630-ECH680 ECH730-ECH749 CH26 CH735 CH745
Ignition (continued)

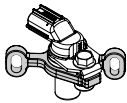
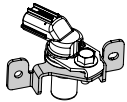
Rectifier-Regulator Fastener (Standard Charging System)	1.4 N·m (12.6 in. lb.)	
Rectifier-Regulator Power Studs/Nuts (High Output Charging System)	4.0 N·m (35 in. lb.)	
Rectifier-Regulator Terminal Block Cover Fastener (High Output Charging System)	2.8 N·m (25 in. lb.)	
Rectifier-Regulator to Bracket Fastener (High Output Charging System)	8.3 N·m (73 in. lb.)	
High Output Charging Fuse Cover/ Bracket Fastener	8.3 N·m (73 in. lb.)	
Rectifier-Regulator Bracket to Cylinder Head Fastener (High Output Charging System)	12.5 N·m (110 in. lb.)	
		
Crankshaft Position Sensor Earlier Design Bracket		
Crankshaft Position Sensor to Bracket Screw	11.3 N·m (100 in. lb.)	
Crankshaft Position Sensor Bracket to Crankcase Screw	8.3 N·m (73 in. lb.)	
		
Crankshaft Position Sensor Later Design Bracket		
Crankshaft Position Sensor to Bracket Screw	6.8 N·m (60 in. lb.)	
Crankshaft Position Sensor Bracket to Crankcase Screw	7.3 N·m (65 in. lb.)	

Intake Manifold

Fastener (torque in 2 increments)	first to 7.8 N·m (69 in. lb.) finally to 10.5 N·m (93 in. lb.)	first to 7.4 N·m (66 in. lb.) finally to 9.9 N·m (88 in. lb.)
Manifold Absolute Pressure (MAP) Sensor Fastener (Engines with Separate MAP and Intake Air Temperature Sensors)	7.3 N·m (65 in. lb.)	
Temperature/Manifold Absolute Pressure (TMAP) Sensor Fastener (Engines with Combined Sensor)	7.3 N·m (65 in. lb.)	
Air Cleaner to Throttle Body Fastener Nut	8.3 N·m (73 in. lb.)	
Heavy-Duty Air Cleaner Mounting Bracket Fastener	5.8 N·m (51 in. lb.)	
Fuel Injector Cap Fastener	7.3 N·m (65 in. lb.)	

³ Values are in Metric units. Values in parentheses are English equivalents.

⁵ Lubricate threads with engine oil prior to assembly.

Specifications

TORQUE SPECIFICATIONS^{3,5}

ECH630-ECH680 ECH730-ECH749

CH26

CH735

CH745

Muffler

Retaining Nut	27.8 N·m (246 in. lb.)	24.4 N·m (216 in. lb.)
Oxygen Sensor smaller 14 mm (9/16 in.) wrench size	18 N·m (159 in. lb.)	
Oxygen Sensor larger 22 mm (7/8 in.) wrench size	50.1 N·m (37 ft. lb.)	

Oil Cooler

Oil Cooler/Adapter Nipple	28.5 N·m (21 ft. lb.)	27 N·m (20 ft. lb.)
Fastener Into Blower Housing Between Oil Cooler Hoses	2.8 N·m (25 in. lb.) 2.3 N·m (20 in. lb.)	

Speed Control Bracket (if equipped)

Fastener Assembled to Cylinder Heads	10.7 N·m (95 in. lb.) into new holes 7.3 N·m (65 in. lb.) into used holes	
Fastener Assembled to Blower Housing	2.8 N·m (25 in. lb.) into new holes 2.3 N·m (20 in. lb.) into used holes	
Fastener Torque		10.7 N·m (95 in. lb.) into new holes 7.3 N·m (65 in. lb.) into used holes

Starter Assembly

Thru Bolt Nippondenso (Solenoid Shift) Delco-Remy (Solenoid Shift)	5.6-9.0 N·m (49-79 in. lb.)	4.5-7.5 N·m (40-84 in. lb.) 5.6-9.0 N·m (49-79 in. lb.)
Mounting Screw	16.0 N·m (142 in. lb.)	15.3 N·m (135 in. lb.)
Brush Holder Mounting Screw Delco-Remy Starter	2.5-3.3 N·m (22-29 in. lb.)	2.5-3.3 N·m (22-29 in. lb.)

Starter Solenoid

Mounting Hardware Nippondenso Starter Delco-Remy Starter	4.0-6.0 N·m (35-53 in. lb.)	6.0-9.0 N·m (53-79 in. lb.) 4.0-6.0 N·m (35-53 in. lb.)
Nut, Positive (+) Brush Lead Nippondenso Starter Delco-Remy Starter	8.0-11.0 N·m (71-97 in. lb.)	8.0-12.0 N·m (71-106 in. lb.) 8.0-11.0 N·m (71-97 in. lb.)

Stator

Mounting Screw	9.3 N·m (82 in. lb.)
----------------	----------------------

Valve Cover

Fastener Gasket Style Cover Black O-Ring Style Cover w/Shoulder Screws w/Flange Screws and Spacers Yellow or Brown O-Ring Style Cover w/Integral Metal Spacers	9.0 N·m (80 in. lb.)	3.4 N·m (30 in. lb.) 5.6 N·m (50 in. lb.) 9.9 N·m (88 in. lb.) 9.0 N·m (80 in. lb.)
----------------------------------------------------------------------------------------------------------------------------------------------------------------------------------	----------------------	----------------------------------------------------------------------------------------------

³ Values are in Metric units. Values in parentheses are English equivalents.

⁵ Lubricate threads with engine oil prior to assembly.

Specifications

CLEARANCE SPECIFICATIONS³

ECH630-ECH680

ECH730-ECH749

CH26

CH735

CH745

Camshaft

End Play (with shim)	0.101/0.406 mm (0.0040/0.0160 in.)	0.076/0.127 mm (0.0030/0.0050 in.)
Running Clearance	0.025/0.105 mm (0.001/0.004 in.)	0.025/0.063 mm (0.0010/0.0025 in.)
Bore I.D. New Max. Wear Limit	20.000/20.025 mm (0.7874/0.7884 in.) 20.038 mm (0.7889 in.)	20.000/20.025 mm (0.7874/0.7884 in.) 20.038 mm (0.7889 in.)
Bearing Surface O.D. New Max. Wear Limit	19.920/19.975 mm (0.7843/0.7864 in.) 19.914 mm (0.7840 in.)	19.962/19.975 mm (0.7859/0.7864 in.) 19.959 mm (0.7858 in.)

Connecting Rod

Connecting Rod-to-Crankpin Running Clearance @ 21°C (70°F) New Max. Wear Limit	0.043/0.073 mm (0.0017/0.0029 in.) 0.088 mm (0.0035 in.)	0.030/0.055 mm (0.0012/0.0022 in.) 0.070 mm (0.0028 in.)
Connecting Rod-to-Crankpin Side Clearance	0.26/0.63 mm (0.0102/0.0248 in.)	0.26/0.63 mm (0.0102/0.0248 in.)
Connecting Rod-to-Piston Pin Running Clearance @ 21°C (70°F)	0.015/0.028 mm (0.0006/0.0011 in.)	0.015/0.028 mm (0.0006/0.0011 in.)
Piston Pin End I.D. @ 21°C (70°F) New Max. Wear Limit	17.015/17.023 mm (0.6699/0.6702 in.) 17.036 mm (0.6707 in.)	17.015/17.023 mm (0.6699/0.6702 in.) 17.036 mm (0.6707 in.)

Crankcase

Governor Cross Shaft Bore I.D. New Max. Wear Limit	8.025/8.075 mm (0.3159/0.3179 in.) 8.088 mm (0.3184 in.)	
6 mm Shaft New Max. Wear Limit		6.025/6.050 mm (0.2372/0.2382 in.) 6.063 mm (0.2387 in.)
8 mm Shaft New Max. Wear Limit		8.025/8.075 mm (0.3159/0.3179 in.) 8.088 mm (0.3184 in.)

Crankshaft

End Play (free)	0.070/0.590 mm (0.0028/0.0230 in.)	0.070/0.590 mm (0.0028/0.0230 in.)
End Play (w/thrust bearing components)	0.070/1.190 mm (0.0028/0.0468 in.)	0.070/1.190 mm (0.0028/0.0468 in.)
Bore (in crankcase) New Max. Wear Limit	40.972/40.997 mm (1.6131/1.6141 in.) 41.011 mm (1.6146 in.)	40.965/41.003 mm (1.6128/1.6143 in.) 41.016 mm (1.6148 in.)
Bore (in closure plate) New	40.974/41.000 mm (1.6131/1.6141 in.)	40.987/40.974 mm (1.6136/1.6131 in.)
Crankshaft to Sleeve Bearing (closure plate) Running Clearance New	0.03/0.12 mm (0.001/0.005 in.)	0.03/0.09 mm (0.0012/0.0035 in.)

³ Values are in Metric units. Values in parentheses are English equivalents.

Specifications

CLEARANCE SPECIFICATIONS³

ECH630-ECH680

ECH730-ECH749

CH26

CH735

CH745

Crankshaft (continued)

Crankshaft Bore (In Closure Plate)-to-Crankshaft Running Clearance New	0.039/0.087 mm (0.0015/0.0034 in.)	0.039/0.074 mm (0.0015/0.0029 in.)
Flywheel End Main Bearing Journal O.D. - New O.D. - Max. Wear Limit Max. Taper Limit Max. Out-of-Round Limit	40.913/40.935 mm (1.6107/1.6116 in.) 40.843 mm (1.608 in.) 0.022 mm (0.0009 in.) 0.025 mm (0.0010 in.)	40.913/40.935 mm (1.6107/1.6116 in.) 40.84 mm (1.608 in.) 0.022 mm (0.0009 in.) 0.025 mm (0.0010 in.)
Closure Plate End Main Bearing Journal O.D. - New O.D. - Max. Wear Limit Max. Taper Limit Max. Out-of-Round Limit	40.913/40.935 mm (1.6107/1.6116 in.) 40.843 mm (1.608 in.) 0.022 mm (0.0009 in.) 0.025 mm (0.0010 in.)	40.913/40.935 mm (1.6107/1.6116 in.) 40.84 mm (1.608 in.) 0.022 mm (0.0009 in.) 0.025 mm (0.0010 in.)
Connecting Rod Journal O.D. - New O.D. - Max. Wear Limit Max. Taper Limit Max. Out-of-Round Limit	35.950/35.973 mm (1.4153/1.4163 in.) 35.941 mm (1.415 in.) 0.018 mm (0.0007 in.) 0.025 mm (0.0010 in.)	35.955/35.973 mm (1.4156/1.4163 in.) 35.94 mm (1.415 in.) 0.018 mm (0.0007 in.) 0.025 mm (0.0010 in.)
Crankshaft T.I.R. PTO End, Crank in Engine Entire Crank, in V-Blocks	0.279 mm (0.0110 in.) 0.10 mm (0.0039 in.)	0.279 mm (0.0110 in.) 0.10 mm (0.0039 in.)

Cylinder Bore

Bore I.D. New	80.000/80.025 mm (3.1496/3.2689 in.)	83.006/83.031 mm (3.2680/3.2689 in.)	82.988/83.013 mm (3.2672/3.2682 in.)
O.D. - Max. Wear Limit	80.075 mm (3.1526 in.)	83.081 mm (3.2709 in.)	83.051 mm (3.2697 in.)
Max. Out-of-Round Limit	0.120 mm (0.0047 in.)		0.12 mm (0.0047 in.)
Max. Taper	0.05 mm (0.0020 in.)		0.05 mm (0.0020 in.)

Cylinder Head

Max. Out-of-Flatness	0.076 mm (0.003 in.)	0.076 mm (0.003 in.)
----------------------	----------------------	----------------------

³ Values are in Metric units. Values in parentheses are English equivalents.

Specifications

CLEARANCE SPECIFICATIONS³

ECH630-ECH680

ECH730-ECH749

CH26

CH735

CH745

Governor (if equipped)

Governor Cross Shaft -to-Crankcase Running Clearance 6 mm Shaft 8 mm Shaft	0.025/0.126 mm (0.0009/0.0049 in.)	0.013/0.075 mm (0.0005/0.0030 in.) 0.025/0.126 mm (0.0009/0.0049 in.)
Cross Shaft O.D. New Max. Wear Limit 6 mm Shaft New Max. Wear Limit 8 mm Shaft New Max. Wear Limit	7.949/8.000 mm (0.3129/0.3149 in.) 7.936 mm (0.3124 in.)	5.975/6.012 mm (0.2352/0.2367 in.) 5.962 mm (0.2347 in.) 7.949/8.000 mm (0.3129/0.3149 in.) 7.936 mm (0.3124 in.)
Governor Gear Shaft -to-Governor Gear Running Clearance	0.090/0.160 mm (0.0035/0.0063 in.)	0.015/0.140 mm (0.0006/0.0055 in.)
Gear Shaft O.D. New Max. Wear Limit	5.990/6.000 mm (0.2358/0.2362 in.) 5.977 mm (0.2353 in.)	

Ignition

Spark Plug Gap	0.76 mm (0.030 in.)	
Crankshaft Position Sensor Air Gap (only on earlier design sensor bracket)	0.2-0.7 mm (0.008-0.027 in.)	
Crankshaft Position Sensor Max. Air Gap (only on later design sensor bracket)	2.794 mm (0.110 in.)	

Piston, Piston Rings, and Piston Pin

Piston Style A 		
Piston-to-Piston Pin Running Clearance	0.006/0.017 mm (0.0002/0.0007 in.)	
Pin Bore I.D. New Max. Wear Limit	17.006/17.012 mm (0.6695/0.6698 in.) 17.025 mm (0.6703 in.)	
Pin O.D. New Max. Wear Limit	16.995/17.000 mm (0.6691/0.6693 in.) 16.994 mm (0.6691 in.)	
Top Compression Ring-to-Groove Side Clearance	0.050/0.095 mm (0.0019/0.0037 in.)	0.025/0.048 mm (0.0010/0.0019 in.)
Middle Compression Ring-to-Groove Side Clearance	0.030/0.075 mm (0.0012/0.00307 in.)	0.015/0.037 mm (0.0006/0.0015 in.)
Oil Control Ring-to-Groove Side Clearance	0.010/0.011 mm (0.0004/0.0043 in.)	0.026/0.176 mm (0.0010/0.0070 in.)
Top and Center Compression Ring End Gap New Bore	0.25/0.56 mm (0.0100/0.0224 in.)	
Used Bore (Max.)	0.80 mm (0.0315 in.)	0.94 mm (0.037 in.)

³ Values are in Metric units. Values in parentheses are English equivalents.

Specifications

CLEARANCE SPECIFICATIONS³



ECH630-ECH680

ECH730-ECH749

CH26

CH735

CH745

Piston Style A  (continued)		
Thrust Face O.D. ⁷	79.943/79.961 mm (3.1473/3.1480 in.)	82.949/82.967 mm (3.2657/3.2664 in.)
Max. Wear Limit	79.816 mm (3.1423 in.)	82.822 mm (3.2606 in.)
Piston Thrust Face-to Cylinder Bore ⁷ Running Clearance New	0.039/0.082 mm (0.0015/0.0032 in.)	
Piston Style B 		
Piston-to-Piston Pin Running Clearance	0.006/0.017 mm (0.0002/0.0007 in.)	
Pin Bore I.D. New Max. Wear Limit	17.006/17.012 mm (0.6695/0.6698 in.) 17.025 mm (0.6703 in.)	
Pin O.D. New Max. Wear Limit	16.995/17.000 mm (0.6691/0.6693 in.) 16.994 mm (0.6691 in.)	
Top Compression Ring-to-Groove Side Clearance	0.030/0.070 mm (0.001/0.0026 in.)	
Middle Compression Ring-to-Groove Side Clearance	0.030/0.070 mm (0.001/0.0026 in.)	
Oil Control Ring-to-Groove Side Clearance	0.060/0.190 mm (0.0022/0.0073 in.)	
Top Compression Ring End Gap New Bore	0.100/0.279 mm (0.0039/0.0110 in.)	0.189/0.277 mm (0.0074/0.0109 in.)
Used Bore (Max.)	0.490 mm (0.0192 in.)	0.531 mm (0.0209 in.)
Middle Compression Ring End Gap New Bore	1.400/1.679 mm (0.0551/0.0661 in.)	1.519/1.797 mm (0.0598/0.0708 in.)
Used Bore (Max)	1.941 mm (0.0764 in.)	2.051 mm (0.0808 in.)
Thrust Face O.D. New	79.966 mm (3.1483 in.) ⁸	82.978 mm (3.2668 in.) ⁷
Max. Wear Limit	79.821 mm (3.1426 in.) ⁸	82.833 mm (3.2611 in.) ⁷
Piston Thrust Face-to Cylinder Bore Running Clearance New	0.025/0.068 mm (0.0010/0.0027 in.) ⁸	0.019/0.062 mm (0.0007/0.0024 in.) ⁷

³ Values are in Metric units. Values in parentheses are English equivalents.

⁷ Measure 6 mm (0.2362 in.) above bottom of piston skirt at right angles to piston pin.

⁸ Measure 13 mm (0.5118 in.) above bottom of piston skirt at right angles to piston pin.

Specifications

CLEARANCE SPECIFICATIONS³

ECH630-ECH680

ECH730-ECH749

CH26

CH735



CH745

Valves and Valve Lifters





Hydraulic Lifter to Crankcase Running Clearance	0.011/0.048 mm (0.0004/0.0019 in.)	0.0241/0.0501 mm (0.0009/0.0020 in.)
Intake Valve Stem-to-Valve Guide Running Clearance	0.040/0.078 mm (0.0016/0.0031 in.)	0.038/0.076 mm (0.0015/0.0030 in.)
Exhaust Valve Stem-to-Valve Guide Running Clearance	0.052/0.090 mm (0.0020/0.0035 in.)	0.050/0.088 mm (0.0020/0.0035 in.)
Ignition Module Air Gap		0.28/0.33 mm (0.011/0.013 in.)
Speed Sensor Air Gap		1.50 ± 0.25 mm (0.059 ± 0.010 in.)
Intake Valve Guide I.D. New Max. Wear Limit	7.040/7.060 mm (0.2772/0.2780 in.) 7.134 mm (0.2809 in.)	7.038/7.058 mm (0.2771/0.2779 in.) 7.134 mm (0.2809 in.)
Exhaust Valve Guide I.D. New Max. Wear Limit	7.040/7.060 mm (0.2772/0.2780 in.) 7.159 mm (0.2819 in.)	7.038/7.058 mm (0.2771/0.2779 in.) 7.159 mm (0.2819 in.)
Guide Reamer Size Standard 0.25 mm O.S.	7.050 mm (0.2776 in.) 7.300 mm (0.2874 in.)	7.048 mm (0.2775 in.) 7.298 mm (0.2873 in.)
Intake Valve Minimum Lift	8.07 mm (0.3177 in.)	
Exhaust Valve Minimum Lift	8.07 mm (0.3177 in.)	
Nominal Valve Seat Angle	45°	

Specifications

GENERAL TORQUE VALUES

English Fastener Torque Recommendations for Standard Applications				
Bolts, Screws, Nuts and Fasteners Assembled Into Cast Iron or Steel				Grade 2 or 5 Fasteners Into Aluminum
Size	 Grade 2	 Grade 5	 Grade 8	
Tightening Torque: N·m (in. lb.) ± 20%				
8-32	2.3 (20)	2.8 (25)	—	2.3 (20)
10-24	3.6 (32)	4.5 (40)	—	3.6 (32)
10-32	3.6 (32)	4.5 (40)	—	—
1/4-20	7.9 (70)	13.0 (115)	18.7 (165)	7.9 (70)
1/4-28	9.6 (85)	15.8 (140)	22.6 (200)	—
5/16-18	17.0 (150)	28.3 (250)	39.6 (350)	17.0 (150)
5/16-24	18.7 (165)	30.5 (270)	—	—
3/8-16	29.4 (260)	—	—	—
3/8-24	33.9 (300)	—	—	—

Tightening Torque: N·m (ft. lb.) ± 20%				
5/16-24	—	—	40.7 (30)	—
3/8-16	—	47.5 (35)	67.8 (50)	—
3/8-24	—	54.2 (40)	81.4 (60)	—
7/16-14	47.5 (35)	74.6 (55)	108.5 (80)	—
7/16-20	61.0 (45)	101.7 (75)	142.5 (105)	—
1/2-13	67.8 (50)	108.5 (80)	155.9 (115)	—
1/2-20	94.9 (70)	142.4 (105)	223.7 (165)	—
9/16-12	101.7 (75)	169.5 (125)	237.3 (175)	—
9/16-18	135.6 (100)	223.7 (165)	311.9 (230)	—
5/8-11	149.5 (110)	244.1 (180)	352.6 (260)	—
5/8-18	189.8 (140)	311.9 (230)	447.5 (330)	—
3/4-10	199.3 (147)	332.2 (245)	474.6 (350)	—
3/4-16	271.2 (200)	440.7 (325)	637.3 (470)	—

Metric Fastener Torque Recommendations for Standard Applications						
Size	Property Class					Noncritical Fasteners Into Aluminum
	 4.8	 5.8	 8.8	 10.9	 12.9	
Tightening Torque: N·m (in. lb.) ± 10%						
M4	1.2 (11)	1.7 (15)	2.9 (26)	4.1 (36)	5.0 (44)	2.0 (18)
M5	2.5 (22)	3.2 (28)	5.8 (51)	8.1 (72)	9.7 (86)	4.0 (35)
M6	4.3 (38)	5.7 (50)	9.9 (88)	14.0 (124)	16.5 (146)	6.8 (60)
M8	10.5 (93)	13.6 (120)	24.4 (216)	33.9 (300)	40.7 (360)	17.0 (150)
Tightening Torque: N·m (ft. lb.) ± 10%						
M10	21.7 (16)	27.1 (20)	47.5 (35)	66.4 (49)	81.4 (60)	33.9 (25)
M12	36.6 (27)	47.5 (35)	82.7 (61)	116.6 (86)	139.7 (103)	61.0 (45)
M14	58.3 (43)	76.4 (56)	131.5 (97)	184.4 (136)	219.7 (162)	94.9 (70)

Torque Conversions	
N·m = in. lb. x 0.113	in. lb. = N·m x 8.85
N·m = ft. lb. x 1.356	ft. lb. = N·m x 0.737

Certain quality tools are designed to help you perform specific disassembly, repair, and reassembly procedures. By using these tools, you can properly service engines easier, faster, and safer! In addition, you'll increase your service capabilities and customer satisfaction by decreasing engine downtime.

Here is a list of tools and their source.

NOTE: Not all tools listed are required to service this engine.

SEPARATE TOOL SUPPLIERS

Rehiko Tools
Contact your local Rehiko source of supply.

SE Tools
415 Howard St.
Lapeer, MI 48446
Phone 810-664-2981
Toll Free 800-664-2981
Fax 810-664-8181

Design Technology Inc.
768 Burr Oak Drive
Westmont, IL 60559
Phone 630-920-1300
Fax 630-920-0011

TOOLS

Description	Source/Part No.
Alcohol Content Tester For testing alcohol content (%) in reformulated/oxygenated fuels.	Rehiko 25 455 11-S
Camshaft Endplay Plate For checking camshaft endplay.	SE Tools KLR-82405
Camshaft Seal Protector (Aegis) For protecting seal during camshaft installation.	SE Tools KLR-82417
Dual Gauge Cylinder Leakdown Tester For checking combustion retention and if cylinder, piston, rings, or valves are worn. Individual component available: Adapter 12 mm x 14 mm (Required for leakdown test on XT-6 engines)	Rehiko 25 761 46-S Design Technology Inc. DTI-731-03
Dealer Tool Kit Complete kit of Rehiko required tools. Components of 25 761 39-S Ignition System Tester Dual Gauge Cylinder Leakdown Test Tool Oil Pressure Test Kit Digital Vacuum/Pressure Tester	Rehiko 25 761 39-S Rehiko 25 455 01-S Rehiko 25 761 46-S Rehiko 25 761 06-S Rehiko 25 455 22-S
Digital Vacuum/Pressure Tester For checking crankcase vacuum. Individual component available: Rubber Adapter Plug	Rehiko 25 455 22-S Design Technology Inc. DTI-721-10
EFI Service Kit For troubleshooting and setting up an EFI engine. Components of 24 761 01-S Fuel Pressure Tester Noid Light 90° Adapter Code Plug, Red Wire Code Plug, Blue Wire Code Plug, Yellow Wire Can Bus Reset Tool, Green Wire Shrader Valve Adapter Hose Wire Probe Set (2 pieces regular wire with clip; 1 piece fused wire) Hose Removal Tool, Dual Size/End (also sold as individual Rehiko tool) K-Line Adapter Jumper Lead Wiring Harness	Rehiko 24 761 01-S Design Technology Inc. DTI-019 DTI-021 DTI-023 DTI-027 DTI-029 DTI-028 DTI-030 DTI-037 DTI-031 DTI-033 Rehiko 25 176 23-S
Rehiko Diagnostic System (KDS) Gen 2 For Laptop or Desktop PC. Components of 25 761 50-S Engine Communication Module 7 Pin to DB9 Cable USB Module to PC Cable 7 Pin to 4 Pin Adapter K-Line Adapter Jumper Lead Wiring Harness	Rehiko 25 761 50-S Rehiko 25 761 47-S Rehiko 25 761 48-S Rehiko 25 761 49-S Rehiko 25 761 53-S Rehiko 25 176 23-S

Tools and Aids

TOOLS

Description	Source/Part No.
Mobile KDS Gen 2 (Wireless) Module (New CAN bus/ETB capable) Replaces the previous Rehlko 25 761 45-S for mobile Android or iOS EFI diagnostics. Components of 25 761 55-S 7 Pin to DB9 Cable 7 Pin to 4 Pin Adapter K-Line Adapter Jumper Lead Wiring Harness	Rehlko 25 761 55-S Rehlko 25 761 48-S Rehlko 25 761 53-S Rehlko 25 176 23-S
Mobile (Wireless) CAN bus Cable Upgrade Kit Updates the previous Rehlko 25 761 45-S Mobile (wireless) Android or iOS tool to allow CAN bus/ETB communications and the ability to perform diagnostics. Components of 25 761 56-S 7 Pin to DB9 Cable 7 Pin to 4 Pin Adapter K-Line Adapter Jumper Lead Wiring Harness	Rehlko 25 761 56-S Rehlko 25 761 48-S Rehlko 25 761 53-S Rehlko 25 176 23-S
Replacement Cable and Adapter Kit For laptop/desktop PC or Mobile (Wireless). Components of 25 761 57-S 7 Pin to DB9 Cable 7 Pin to 4 Pin Adapter	Rehlko 25 761 57-S Rehlko 25 761 48-S Rehlko 25 761 53-S
Flywheel Puller For properly removing flywheel from engine.	SE Tools KLR-82408
Flywheel Anchor Bolts, Washers, Nuts Tool Used with Flywheel Puller for properly removing flywheel from 5400 Series engine.	Rehlko 25 086 753-S
Hose Removal Tool, Dual Size/End (also available in EFI Service Kit) Used to properly remove fuel hose from engine components.	Rehlko 25 455 20-S
Ignition System Tester For testing output on all systems, including CD.	Rehlko 25 455 01-S
Inductive Tachometer (Digital) For checking operating speed (RPM) of an engine.	Design Technology Inc. DTI-110
Oil Pressure Test Kit For testing/verifying oil pressure on pressure lubricated engines.	Rehlko 25 761 06-S
Rectifier-Regulator Tester (120 volt current) Rectifier-Regulator Tester (240 volt current) For testing rectifier-regulators. Components of 25 761 20-S and 25 761 41-S CS-PRO Regulator Test Harness Special Regulator Test Harness with Diode	Rehlko 25 761 20-S Rehlko 25 761 41-S Design Technology Inc. DTI-031R DTI-033R
Spark Advance Module (SAM) Tester For testing SAM (ASAM and DSAM) on engines with SMART-SPARK™.	Rehlko 25 761 40-S
Starter Servicing Kit (All Starters) For removing and reinstalling drive retaining rings and brushes. Individual component available: Starter Brush Holding Tool (Solenoid Shift)	SE Tools KLR-82411 SE Tools KLR-82416
Stepper Motor Controller Tool For testing operation of stepper motor/Digital Linear Actuator (DLA).	Rehlko 25 455 21-S
Jumper Lead Tool For use with Stepper Motor Controller Tool to test rotary stepper motor.	Rehlko 25 518 43-S
Triad/OHC Timing Tool Set For holding cam gears and crankshaft in timed position while installing timing belt.	Rehlko 28 761 01-S
Valve Guide Reamer (K and M Series) For properly sizing valve guides after installation.	Design Technology Inc. DTI-K828
Valve Guide Reamer O.S. (Command Series) For reaming worn valve guides to accept replacement oversize valves. Can be used in low-speed drill press or with handle below for hand reaming.	Rehlko 25 455 12-S
Reamer Handle For hand reaming using Rehlko 25 455 12-S reamer.	Design Technology Inc. DTI-K830

AIDS

Description	Source/Part No.
Camshaft Lubricant (Valspar ZZ613)	Rehiko 25 357 14-S
Dielectric Grease	Loctite® 51360
Rehiko Electric Starter Drive Lubricant (Inertia Drive)	Rehiko 52 357 01-S
P80 Emulsion Lubricant	Rehiko 25 357 80-S
RTV Silicone Sealant Loctite® 5900® Heavy Body in 4 oz. aerosol dispenser. Only oxime-based, oil resistant RTV sealants, such as those listed, are approved for use. Permatex® the Right Stuff® 1 Minute Gasket™ or Loctite® Nos. 5900® or 5910® are recommended for best sealing characteristics.	Rehiko 25 597 07-S Loctite® 5910® Loctite® Ultra Black 598™ Loctite® Ultra Blue 587™ Loctite® Ultra Copper 5920™ Permatex® the Right Stuff® 1 Minute Gasket™
Spline Drive Lubricant	Rehiko 25 357 12-S

FLYWHEEL HOLDING TOOL

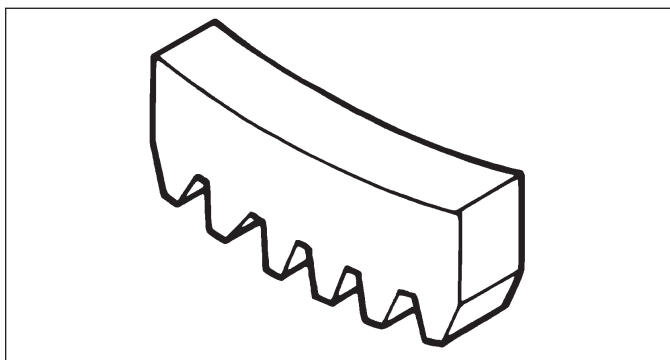

A flywheel holding tool can be made out of an old junk flywheel ring gear and used in place of a strap wrench.

1. Using an abrasive cut-off wheel, cut out a six tooth segment of ring gear as shown.
2. Grind off any burrs or sharp edges.
3. Invert segment and place it between ignition bosses on crankcase so tool teeth engage flywheel ring gear teeth. Bosses will lock tool and flywheel in position for loosening, tightening, or removing with a puller.

ROCKER ARM/CRANKSHAFT TOOL

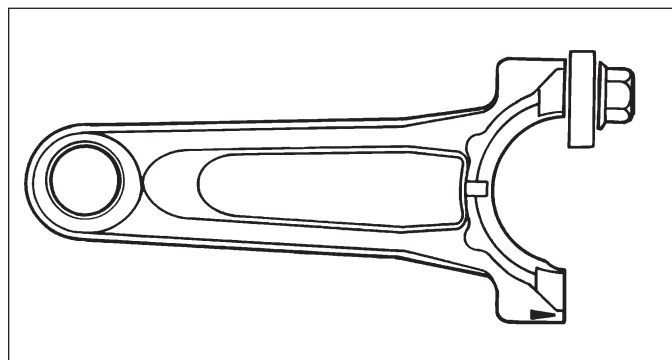

A spanner wrench to lift rocker arms or turn crankshaft may be made out of an old junk connecting rod.

1. Find a used connecting rod from a 10 HP or larger engine. Remove and discard rod cap.
2. Remove studs of a Posi-Lock rod or grind off aligning steps of a Command rod, so joint surface is flat.
3. Find a 1 in. long capscrew with correct thread size to match threads in connecting rod.
4. Use a flat washer with correct I.D. to slip on capscrew and approximately 1 in. O.D. Assemble capscrew and washer to joint surface of rod.

Troubleshooting

TROUBLESHOOTING GUIDE

When troubles occur, be sure to check simple causes which, at first, may seem too obvious to be considered. For example, a starting problem could be caused by an empty fuel tank.

Some general common causes of EFI engine troubles are listed below and vary by engine specification. Use these to locate causing factors.

Engine Cranks But Will Not Start

- Battery connected backwards.
- Blown fuse.
- Clogged fuel line or fuel filter.
- Empty fuel tank.
- Faulty electronic control unit.
- Faulty ignition coil(s).
- Faulty spark plug(s).
- Fuel pump malfunction-vacuum hose clogged or leaking.
- Fuel shut-off valve closed.
- Insufficient voltage to electronic control unit.
- Interlock switch is engaged or faulty.
- Key switch or kill switch in OFF position.
- Low oil level.
- Quality of fuel (dirt, water, stale, mixture).
- Spark plug lead(s) disconnected.

Engine Starts But Does Not Keep Running

- Faulty cylinder head gasket.
- Faulty or misadjusted throttle controls.
- Fuel pump malfunction-vacuum hose clogged or leaking.
- Intake system leak.
- Loose wires or connections that intermittently ground ignition kill circuit.
- Quality of fuel (dirt, water, stale, mixture).
- Restricted fuel tank cap vent.

Engine Starts Hard

- Clogged fuel line or fuel filter.
- Engine overheated.
- Faulty ACR mechanism (Retractable Start).
- Faulty or misadjusted throttle controls.
- Faulty spark plug(s).
- Flywheel key sheared.
- Fuel pump malfunction-vacuum hose clogged or leaking.
- Interlock switch is engaged or faulty.
- Loose wires or connections that intermittently ground ignition kill circuit.
- Low compression.
- Quality of fuel (dirt, water, stale, mixture).
- Weak spark.

Engine Will Not Crank

- Battery is discharged.
- Faulty electric starter or solenoid.
- Faulty key switch or ignition switch.
- Interlock switch is engaged or faulty.
- Loose wires or connections that intermittently ground ignition kill circuit.
- Pawls not engaging in drive cup (Retractable Start).
- Seized internal engine components.

Engine Runs But Misses

- Engine overheated.
- Faulty spark plug(s).
- Ignition coil(s) faulty.
- Incorrect crankshaft position sensor air gap (only on engines with earlier design bracket with slots allowing adjustment).
- Interlock switch is engaged or faulty.
- Loose wires or connections that intermittently ground ignition kill circuit.
- Quality of fuel (dirt, water, stale, mixture).
- Spark plug lead(s) disconnected.
- Spark plug lead boot loose on plug.
- Spark plug lead loose.

Engine Will Not Idle

- Engine overheated.
- Faulty spark plug(s).
- Idle speed adjusting screw improperly set (this is not a feature on engines equipped with an electronic throttle body).
- Inadequate fuel supply.
- Low compression.
- Quality of fuel (dirt, water, stale, mixture).
- Restricted fuel tank cap vent.

Engine Overheats

- Cooling fan broken.
- Excessive engine load.
- High crankcase oil level.
- Lean fuel mixture.
- Low crankcase oil level.
- Cooling system components clogged or restricted.

Engine Knocks

- Excessive engine load.
- Hydraulic lifter malfunction.
- Incorrect oil viscosity/type.
- Internal wear or damage.
- Low crankcase oil level.
- Quality of fuel (dirt, water, stale, mixture).

Engine Loses Power

- Dirty air cleaner element.
- Engine overheated.
- Excessive engine load.
- Restricted exhaust.
- Faulty spark plug(s).
- High crankcase oil level.
- Incorrect governor setting (on engines equipped with electronic throttle body governor is digitally controlled and not adjustable).
- Low battery.
- Low compression.
- Low crankcase oil level.
- Quality of fuel (dirt, water, stale, mixture).

Engine Uses Excessive Amount of Oil

- Loose or improperly torqued fasteners.
- Blown head gasket/overheated.
- Breather reed broken.
- Clogged, broken, or inoperative crankcase breather.
- Crankcase overfilled.
- Incorrect oil viscosity/type.
- Worn cylinder bore.
- Worn or broken piston rings.
- Worn valve stems/valve guides.

Oil Leaks from Oil Seals, Gaskets

- Breather reed broken.
- Clogged, broken, or inoperative crankcase breather.
- Loose or improperly torqued fasteners.
- Piston blow by, or leaky valves.
- Restricted exhaust.

EXTERNAL ENGINE INSPECTION

NOTE: It is good practice to drain oil at a location away from workbench. Be sure to allow ample time for complete drainage.

Before cleaning or disassembling engine, make a thorough inspection of its external appearance and condition. This inspection can give clues to what might be found inside engines (and cause) when it is disassembled.

- Check for buildup of dirt and debris on crankcase, cooling fins, grass screen, and other external surfaces. Dirt or debris on these areas can cause overheating.
- Check for obvious fuel and oil leaks, and damaged components. Excessive oil leakage can indicate a clogged or inoperative breather, worn or damaged seals or gaskets, or loose fasteners.
- Check air cleaner cover and base for damage or indications of improper fit and seal.
- Check air cleaner element. Look for holes, tears, cracked or damaged sealing surfaces, or other damage that could allow unfiltered air into engine. A dirty or clogged element could indicate insufficient or improper maintenance.
- Check throttle body throat for dirt. Dirt in throat is further indication that air cleaner was not functioning properly.
- Check if oil level is within operating range on dipstick. If it is above, sniff for gasoline odor.
- Check condition of oil. Drain oil into a container; it should flow freely. Check for metal chips and other foreign particles.

Sludge is a natural by-product of combustion; a small accumulation is normal. Excessive sludge formation could indicate over rich fuel settings, weak ignition, overextended oil change interval or wrong weight or type of oil was used.

CLEANING ENGINE

	⚠ WARNING
	<p>Cleaning Solvents can cause severe injury or death.</p> <p>Use only in well ventilated areas away from ignition sources.</p>
<p>Carburetor cleaners and solvents are extremely flammable. Follow cleaner manufacturer's warnings and instructions on its proper and safe use. Never use gasoline as a cleaning agent.</p>	

After inspecting external condition of engine, clean engine thoroughly before disassembly. Clean individual components as engine is disassembled. Only clean parts can be accurately inspected and gauged for wear or damage. There are many commercially available cleaners that will quickly remove grease, oil, and grime from engine parts. When such a cleaner is used, follow manufacturer's instructions and safety precautions carefully.

Make sure all traces of cleaner are removed before engine is reassembled and placed into operation. Even small amounts of these cleaners can quickly break down lubricating properties of engine oil.

Troubleshooting

CRANKCASE VACUUM TEST

	⚠ WARNING
	Carbon Monoxide can cause severe nausea, fainting or death. Avoid inhaling exhaust fumes. Never run engine indoors or in enclosed spaces.
Engine exhaust gases contain poisonous carbon monoxide. Carbon monoxide is odorless, colorless, and can cause death if inhaled.	

	⚠ WARNING
	Rotating Parts can cause severe injury. Stay away while engine is in operation.
Keep hands, feet, hair, and clothing away from all moving parts to prevent injury. Never operate engine with covers, shrouds, or guards removed.	

A partial vacuum should be present in crankcase when engine is operating. Pressure in crankcase (normally caused by a clogged or improperly assembled breather) can cause oil to be forced out at oil seals, gaskets, or other available spots.

Crankcase vacuum is best measured with either a water manometer or a vacuum gauge (inches of water gauge only). Complete instructions are provided in kits.

To test crankcase vacuum with manometer:

1. Insert rubber stopper into oil fill hole. Be sure pinch clamp is installed on hose and use tapered adapters to connect hose between stopper and one manometer tube. Leave other tube open to atmosphere. Check that water level in manometer is at 0 line. Make sure pinch clamp is closed.
2. Start engine and run no-load high speed.
3. Open clamp and note water level in tube.
Level in engine side should be a minimum of 10.2 cm (4 in.) above level in open side.
If level in engine side is less than specified (low/no vacuum), or level in engine side is lower than level in open side (pressure), check for conditions in table below.
4. Close pinch clamp before stopping engine.

To test crankcase vacuum with vacuum/pressure gauge (inches of water gauge only):

1. Remove dipstick or oil fill plug/cap.
2. Install adapter into oil fill/dipstick tube opening, upside down over end of a small diameter dipstick tube, or directly into engine if a tube is not used. Insert barbed gauge fitting into hole in stopper.
3. Run engine and observe gauge reading.
Analog tester—needle movement to left of 0 is a vacuum, and movement to right indicates a pressure.
Digital tester—depress test button on top of tester.
Crankcase vacuum should be a minimum of 10.2 cm (4 in.) of water. If reading is below specification, or if pressure is present, check table below for possible causes and conclusions.

Condition	Conclusion
Crankcase breather clogged or inoperative.	NOTE: If breather is integral part of valve cover and cannot be serviced separately, replace valve cover and recheck pressure. Disassemble breather, clean parts thoroughly, check sealing surfaces for flatness, reassemble, and recheck pressure.
Seals and/or gaskets leaking. Loose or improperly torque fasteners.	Replace all worn or damaged seals and gaskets. Make sure all fasteners are tightened securely. Use appropriate torque valves and sequences when necessary.
Piston blow by or leaky valves (confirm by inspecting components).	Recondition piston, rings, cylinder bore, valves and valves guides.
Restricted exhaust.	Check exhaust screen/spark arrestor (if equipped). Clean or replace as needed. Repair or replace any other damaged/restricted muffler or exhaust system parts.

COMPRESSION TEST

NOTE: On engines with electronic throttle body (ETB), use Compression test within Rehlko Diagnostic System (KDS) Gen 2. See instructions within help (?) area of compression test.

A compression test is best performed on a warm engine. Clean any dirt or debris away from base of spark plugs before removing them. Be sure battery is fully charged, unplug ECU, and throttle is wide open during test. Compression should be at least 160 psi and should not vary more than 15% between cylinders.

Some models (retractable start) are equipped with an automatic compression release (ACR) mechanism. It is difficult to obtain an accurate compression reading because of ACR mechanism. As an alternative, use cylinder leakdown test described below.

CYLINDER LEAKDOWN TEST

A cylinder leakdown test can be a valuable alternative to a compression test. By pressurizing combustion chamber from an external air source you can determine if valves or rings are leaking, and how badly.

Cylinder leakdown tester is a relatively simple, inexpensive leakdown tester for small engines. This tester includes a quick-connect for attaching adapter hose and a holding tool.

Dual Gauge Test Procedure

1. Run engine until oil temperature reaches and maintains 150°F (66°C) or more for a minimum of 5 minutes. Ideally, engine should be run under normal load conditions.
2. Remove spark plug(s) and air filter from engine.
3. Rotate crankshaft until piston (of cylinder being tested) is at top dead center (TDC) of compression stroke. Hold engine in this position while testing. Holding tool from kit can be used if PTO end of crankshaft is accessible. Lock holding tool onto crankshaft. Install a 3/8 in. breaker bar into hole/slot of holding tool, so it is perpendicular to both holding tool and crankshaft PTO.

If flywheel end is more accessible, use a breaker bar and socket on flywheel nut/screw to hold it in position. An assistant may be needed to hold breaker bar during testing. If engine is mounted in a piece of equipment, it may be possible to hold it by clamping or wedging a driven component. Just be certain engine cannot rotate off TDC in either direction.

4. Connect an air source (at least 100 PSI) to tool.
5. Turn regulator knob clockwise (increase direction). Confirm both gauges read approximately the same air pressure from 0 to 80 PSI. Note any discrepancies between gauges for leakage calculation. Release pressure by turning regulator knob completely counterclockwise before proceeding.
6. Install adapter hose into spark plug hole of cylinder being tested. Use 12 mm x 14 mm adapter if required.
7. Firmly hold engine at TDC. Connect other end of adapter hose to tool quick connect. Turn regulator knob clockwise (increase direction) until left gauge needle reads 20 PSI.

NOTE: When piston is at TDC, little to no holding force should be required when air pressure is applied to cylinder. If excess holding force is required, this indicates piston is not at TDC. Readjust as necessary before proceeding.

8. Slowly turn regulator knob clockwise until left hand gauge maintains selected test pressure (see chart below).

Left Gauge Regulated Pressure Selection
<p>80 PSI Recommended for engines over 200 cc or those exhibiting high leakage at 35 PSI setting.</p>
<p>35 PSI Recommended for single cylinder walk-behind push mower applications.</p>

9. Compare right gauge reading to Test Pressure Chart on next page to identify percentage of leakage. Also refer to Leakdown Test Results chart on next page for colors, conditions, and action required.
10. For engines exhibiting leakage in yellow or red zone, repeat test procedure. Operate engine under normal load conditions prior to test. Confirm piston is at TDC during test.

NOTE: To prevent damage to gauge assembly, always turn pressure regulator knob to zero (counterclockwise) after each test.

Troubleshooting

Test Pressure Chart for Dual Gauge Tool

Left Gauge Regulated Pressure Selection	Right Gauge Reading in PSI										
80 PSI Recommended for engines over 200 cc or those exhibiting high leakage at 35 PSI setting.	80	72	64	56	48	40	32	24	16	8	0
35 PSI Recommended for single cylinder walk-behind push mower applications.	35	31.5	28	24.5	21	17.5	14	10.5	7	3.5	0
Percentage of leakage	0%	10%	20%	30%	40%	50%	60%	70%	80%	90%	100%
	Green Zone				Yellow Zone			Red Zone			

Leakdown Test Results

Test Result	Condition	Action
Gauge reading in low (green) zone.	Piston rings and cylinder in good condition.	No further action required.
Gauge reading in moderate (yellow) zone.	Air escaping from crankcase breather and/or dipstick tube.	Some wear present causing leakage from combustion chamber to crankcase. Repair not required at this time if breather system is functioning normally.
	Air escaping from exhaust.	Exhaust valve leakage present, possibly due to carbon deposits. Repair not required. Carbon cleaning could be performed to reduce leakage.
	Air escaping from intake.	Intake valve leakage present, possibly due to carbon deposits. Repair not required. Carbon cleaning could be performed to reduce leakage.
Gauge reading in high (red) zone. Confirm consecutive leakdown test has been performed AFTER engine has been operated under normal load conditions.	Air escaping from crankcase breather and/or dipstick tube.	Excess wear present causing leakage from combustion chamber to crankcase. Breather system will not function normally and will fail crankcase vacuum test if this condition is truly present. Engine disassembly and analysis required to determine root cause and correction.
	Air escaping from exhaust.	Excess exhaust valve leakage present, possibly due to carbon deposits and/or valve to seat sealing issues. Carbon cleaning may reduce leakage. Valve grind and/or component replacement may be necessary. Excess oil consumption and/or excess heat is a suspect cause and must be resolved to prevent reoccurrence.
	Air escaping from intake.	Excess intake valve leakage present, possibly due to carbon deposits and/or valve to seat sealing issues. Carbon cleaning may reduce leakage. Valve grind and/or component replacement may be necessary. Excess oil consumption through intake valve and/or excess heat is a suspect cause and must be resolved to prevent reoccurrence. Inspect breather system components and intake valve stem sealing.

AIR CLEANER

These systems are CARB/EPA certified and components should not be altered or modified in any way.

Low-Profile Air Cleaner

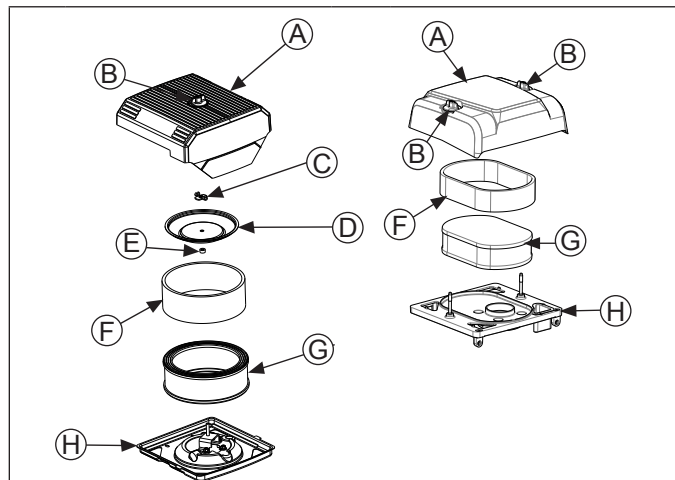

A	Air Cleaner Cover	B	Air Cleaner Knob
C	Wing Nut	D	Element Cover
E	Rubber Seal	F	Precleaner
G	Paper Element	H	Air Cleaner Base

Heavy-Duty Air Cleaner

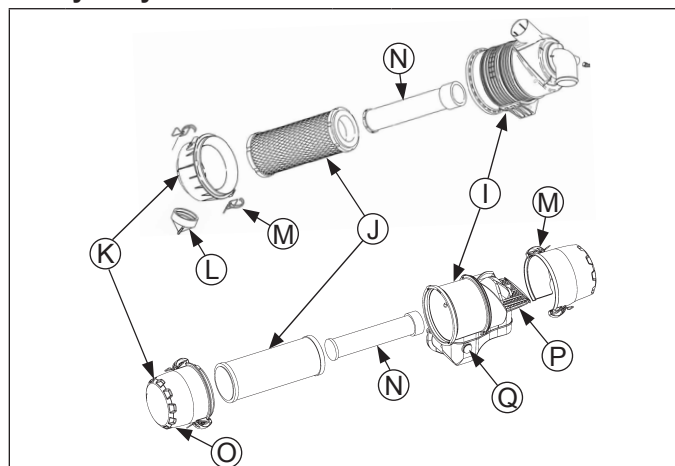

I	Air Cleaner Housing	J	Element
K	End Cap	L	Dust Ejector Valve
M	Retaining Clip	N	Inner Element
O	Ejector Area	P	Inlet Screen
Q	Filter Minder		

NOTE: Operating engine with loose or damaged air cleaner components could cause premature wear and failure. Replace all bent or damaged components.

NOTE: Paper element cannot be blown out with compressed air.

Low-Profile

Loosen knob(s) and remove air cleaner cover.

Precleaner

1. Remove precleaner from paper element.
2. Replace or wash precleaner in warm water with detergent. Rinse and allow to air dry.
3. Saturate precleaner with new engine oil; squeeze out excess oil.
4. Reinstall precleaner over paper element.

Paper Element

1. Clean area around element. If equipped, remove wing nut and element cover. Remove paper element with precleaner.
2. Separate precleaner from element; service precleaner and replace paper element.
3. If equipped, check condition of rubber seal and replace if necessary.
4. Install new paper element on base; install precleaner over paper element. If equipped, reinstall element cover and secure with wing nut.

Reinstall air cleaner cover and secure with knob(s).

Heavy-Duty

1. Unhook retaining clips and remove end cap(s).
2. Check and clean inlet screen (if equipped).
3. Pull air cleaner element out of housing and replace. Check condition of inner element; replace when dirty.
4. Check all parts for wear, cracks, or damage, and that ejector area is clean.
5. Install new element(s).
6. Reinstall end cap(s) with dust ejector valve/screen down; secure with retaining clips.

BREATHER TUBE

Ensure sure both ends of breather tube are properly connected.

AIR COOLING

	WARNING
	Hot Parts can cause severe burns. Do not touch engine while operating or just after stopping.
Never operate engine with heat shields or guards removed.	

Proper cooling is essential. To prevent over heating, clean screens, cooling fins, and other external surfaces of engine. Inspect for any debris visible through flywheel cooling holes (if equipped) and clean as necessary. Avoid spraying water at wiring harness or any electrical components. Refer to Maintenance Schedule.

EFI SYSTEM-ELECTRONIC THROTTLE BODY (ETB) ECH

	⚠ WARNING
	Explosive Fuel can cause fires and severe burns. Do not fill fuel tank while engine is hot or running.
Gasoline is extremely flammable and its vapors can explode if ignited. Store gasoline only in approved containers, in well ventilated, unoccupied buildings, away from sparks or flames. Spilled fuel could ignite if it comes in contact with hot parts or sparks from ignition. Never use gasoline as a cleaning agent.	

Typical electronic fuel injection (EFI) system and related components include:

- Fuel pump module and lift pump.
- Fuel filter.
- High pressure fuel line.
- Fuel line(s).
- Fuel injectors.
- Electronic throttle body (ETB)/intake manifold.
- Electronic control unit (ECU).
- Ignition coils.
- Engine temperature sensor or Engine temperature sensor lead.
- Throttle position sensor (TPS) is contactless and not serviceable.
- Crankshaft position sensor.
- Oxygen sensor.
- Temperature/manifold absolute pressure (TMAP) sensor.
- Malfunction indicator light (MIL)-optional.
- 30 Amp fuse (charging system).
- Rehlko 60 Amp fuse (high output charging system).
- 10 Amp fuse (ignition switched power).
- 10 Amp fuse (battery power).
- Wire harness assembly & affiliated wiring.

FUEL RECOMMENDATIONS

Refer to Maintenance.

FUEL LINE

Low permeation fuel line must be installed on all Rehlko engines to maintain EPA and CARB regulatory compliance.

OPERATION

NOTE: When performing voltage or continuity tests, avoid putting excessive pressure on or against connector pins. Flat pin probes are recommended for testing to avoid spreading or bending terminals.

EFI system is designed to provide peak engine performance with optimum fuel efficiency and lowest possible emissions. Ignition and injection functions are electronically controlled, monitored and continually corrected during operation to maintain ideal air/fuel ratio.

Central component of system is Electronic Control Unit (ECU) which manages system operation, determining best combination of fuel mixture, ignition timing, throttle opening and/or engine RPM for current operating conditions.

ETB engines feature an ECU that uses CAN BUS/ J1939 communication protocols and may be linked to other electronic control modules installed on application. Some models are configured for analog speed control input, while most others utilize CAN BUS for operator input control. Please refer to equipment manufacturer's manual to determine if equipped and operational detail. Native fault codes are in line with J1939 protocol. We continue to reference P Codes for consistency.

A lift fuel pump is used to move fuel from tank through an in-line fuel filter and fuel line. Fuel is then pumped to fuel pump module. Fuel pump module regulates fuel pressure to a system operating pressure of 39 psi. Fuel is delivered from fuel pump module through high pressure fuel line into injectors, which inject fuel into intake ports. ECU controls amount of fuel by varying length of time that injectors are on. This can range from 2 to over 12 milliseconds depending on fuel requirements. Controlled injection of fuel occurs every other crankshaft revolution, or once for each 4-stroke cycle. When intake valve opens, air/fuel mixture is drawn into combustion chamber, compressed, ignited, and burned.

ECU controls amount of fuel being injected and ignition timing by monitoring primary sensor signals for engine temperature, operator requested engine speed (RPM), and throttle position (load). These primary signals are compared to preprogrammed maps in ECU computer chip, and ECU adjusts fuel delivery to match mapped values. After engine reaches operating temperature, an exhaust gas oxygen sensor provides feedback to ECU based upon amount of unused oxygen in exhaust, indicating whether fuel mixture being delivered is rich or lean. Based upon this feedback, ECU further adjusts fuel input to re-establish ideal air/fuel ratio. This operating mode is referred to as closed loop operation. EFI system operates closed loop when all three of following conditions are met:

- Engine temperature is greater than 50-60°C (122-140°F).
- Oxygen sensor has warmed sufficiently to provide a signal (minimum 400°C, 752°F).
- Engine operation is at a steady state (not starting, warming up, accelerating, etc.).

During closed loop operation ECU has ability to readjust and learn adaptive controls, providing compensation for changes in overall engine condition and operating environment, so it will be able to maintain ideal air/fuel ratio. This system requires a minimum engine temperature greater than 50-60°C (122-140°F) to properly adapt. These adaptive values are maintained as long as ECU is not reset.

During certain operating periods such as cold starts, warm up, acceleration, high load, etc., a richer air/fuel ratio is required and system operates in an open loop mode. In open loop operation oxygen sensor output is used to ensure engine is running rich, and controlling adjustments are based on primary sensor signals and programmed maps only. This system operates open loop whenever three conditions for closed loop operation (above) are not being met.

EFI SYSTEM-ELECTRONIC THROTTLE BODY (ETB) ECH

ECU is brain or central processing computer of entire EFI and ETB/electronic governor system. During operation, sensors continuously gather data which is relayed through wiring harness to input circuits within ECU. Signals to ECU include: ignition (on/off), crankshaft position and speed (RPM), throttle position, requested customer speed input, oil temperature, intake air temperature, exhaust oxygen levels, manifold absolute pressure, and battery voltage.

ECU compares input signals to programmed maps in its memory to determine appropriate fuel and spark requirements for immediate operating conditions. ECU then sends output signals to set injector duration, ignition timing, and ETB throttle opening.

ECU continually performs a diagnostic check of itself, each sensor, and system performance. If a fault is detected, ECU can turn on a Malfunction Indicator Light (MIL) (if equipped) on equipment control panel, store fault code in its fault memory, and go into a default operating mode. Depending on significance or severity of fault, normal operation may continue. A technician can access stored fault code using a blink code diagnosis flashed out through MIL or use Rehlko Diagnostic System (KDS) Gen 2, see Tools and Aids.

ECU requires a minimum of 6.0 volts to operate.

To prevent engine over-speed and possible failure, a rev-limiting feature is programmed into ECU. If maximum RPM limit (4500) is exceeded, ECU suppresses injection signals, cutting off fuel flow. This process repeats itself in rapid succession, limiting operation to preset maximum.

Wiring harness used in EFI system connects electrical components, providing current and ground paths for system to operate. All input and output signaling occurs through two special all weather connectors that attach and lock to ECU. Connectors are Black and Grey and keyed differently to prevent being attached to ECU incorrectly.

Condition of wiring, connectors, and terminal connections is essential to system function and performance. Corrosion, moisture, and poor connections are as likely cause of operating problems and system errors as an actual component. Refer to Electrical System for additional information.

EFI system is a 12 VDC negative ground system, designed to operate down to a minimum of 6.0 volts. If system voltage drops below this level, operation of voltage sensitive components such as ECU, fuel pump, ignition coils, and injectors will be intermittent or disrupted, causing erratic operation or hard starting. A fully charged, 12 volt battery with a minimum of 350 cold cranking amps is important in maintaining steady and reliable system operation. Battery condition and state of charge should always be checked first when troubleshooting an operational problem.

Keep in mind that EFI-related problems are often caused by wiring harness or connections. Even small amounts of corrosion or oxidation on terminals can interfere with milliamp currents used in system operation.

Cleaning connectors and grounds will solve problems in many cases. In an emergency situation, simply disconnecting and reconnecting connectors may clean up contacts enough to restore operation, at least temporarily.

If a fault code indicates a problem with an electrical component, disconnect ECU connector and test for continuity between component connector terminals and corresponding terminals in ECU connector using an ohmmeter. Little or no resistance should be measured, indicating that wiring of that particular circuit is OK.

Crankshaft position sensor is essential to engine operation; constantly monitoring rotation and speed (RPM) of crankshaft. There are 23 consecutive teeth cast into flywheel. One tooth is missing and is used to reference crankshaft position for ECU.

During rotation, an AC voltage pulse is created within sensor for each passing tooth. ECU calculates engine speed from time interval between consecutive pulses. Gap from missing tooth creates an interrupted input signal, corresponding to specific crankshaft position near BDC for cylinder #1. This signal serves as a reference for control of ignition timing by ECU. Synchronization of inductive speed pickup and crankshaft position takes place during first two revolutions each time engine is started. Sensor must be properly connected at all times. If sensor becomes disconnected for any reason, engine will quit running.

Throttle position sensor (TPS) is used to indicate throttle plate angle to ECU. Since throttle (by way of governor or customer speed input/ETB throttle opening) reacts to engine load, angle of throttle plate is directly related to load on engine.

TPS is sealed and not serviced separately. Mounted on electronic throttle body and operated directly off end of throttle shaft, TPS works as a potentiometer, varying voltage signal to ECU in direct correlation to angle of throttle plate. This signal, along with other sensor signals, is processed by ECU and compared to internal preprogrammed maps to determine required fuel and ignition settings for amount of load.

TPS auto-learn is an automated process. No adjustment is required.

Most models feature an engine temperature sensor located in breather cover, while other models feature an engine temperature sensor lead that secures on #2 cylinder valley baffle screw closest to exhaust port. Both types utilize a temperature-sensitive resistor. Resistance changes with engine temperature, altering voltage sent to ECU. Using a table stored in its memory, ECU correlates voltage drop to a specific temperature. Using fuel delivery maps, ECU then knows how much fuel is required for starting at that temperature.

Temperature/Manifold Absolute Pressure (TMAP) sensor is an integrated sensor that checks both intake air temperature and manifold absolute pressure.

Intake Air Temperature control is a thermally sensitive resistor that exhibits a change in electrical resistance with a change in its temperature. When sensor is cold, resistance of sensor is high. As sensor warms up, resistance drops and voltage signal increases. From voltage signal, ECU can determine temperature of intake air.

EFI SYSTEM-ELECTRONIC THROTTLE BODY (ETB) ECH

Purpose of sensing air temperature is to help ECU calculate air density. Higher air temperature less dense air becomes. As air becomes less dense ECU knows that it needs to lessen fuel flow to achieve correct air/fuel ratio. If fuel ratio was not changed engine would become rich, possibly losing power and consuming more fuel.

Manifold Absolute Pressure check provides immediate manifold pressure information to ECU. TMAP sensor measures difference in pressure between outside atmosphere and vacuum level inside intake manifold and monitors pressure in manifold as primary means of detecting load. Data is used to calculate air density and determine engine's mass air flow rate, which in turn determines required ideal fueling. MAP also stores instant barometric pressure reading when key is turned ON.

Oxygen sensor functions like a small battery, generating a voltage signal to ECU based upon difference in oxygen content between exhaust gas and ambient air.

Tip of sensor protrudes into exhaust gas. When oxygen concentration on one side of tip is different than that of other side, a voltage signal up to 0.98 volt is generated and sent to ECU. Voltage signal tells ECU if engine is straying from ideal fuel mixture, and ECU then adjusts injector pulse accordingly.

Oxygen sensor functions after being heated to a minimum of 400°C (752°F). A heater inside sensor heats electrode to optimum temperature in about 10 seconds. Oxygen sensor receives ground through wire, eliminating need for proper grounding through muffler. If problems indicate a bad oxygen sensor, check all connections and wire harness. Oxygen sensor can also be contaminated by leaded fuel, certain RTV and/or other silicone compounds, fuel injector cleaners, etc. Use only those products indicated as O2 Sensor Safe.

Fuel injectors mount into intake manifold, and high pressure fuel line attaches to them at top end. Replaceable O-rings on both ends of injector prevent external fuel leakage and also insulate it from heat and vibration. A special clip connects each injector to high pressure fuel line and holds it in place. O-rings and retaining clip must be replaced any time fuel injector is separated from its normal mounting position.

When key switch is on, fuel pump module will pressurize high pressure fuel line to 39 psi, and voltage is present at injector. At proper instant, ECU completes ground circuit, energizing injector. Valve needle in injector is opened electromagnetically, and pressure in high pressure fuel line forces fuel down through inside. Director plate at tip of injector contains a series of calibrated openings which directs fuel into manifold in a cone-shaped spray pattern.

Injectors have sequential fueling that open and close once every other crankshaft revolution. Amount of fuel injected is controlled by ECU and determined by length of time valve needle is held open, also referred to as injection duration or pulse width. Time injector is open (milliseconds) may vary in duration depending on speed and load requirements of engine.

A high-voltage, solid-state, battery ignition system is used with EFI system. ECU controls ignition output and timing through transistorized control of primary current delivered to coils. Based on input from crankshaft position sensor, ECU determines correct firing point for speed at which engine is running. At proper instant, it interrupts flow of primary current in coil, causing electromagnetic flux field to collapse. Flux collapse induces an instantaneous high voltage in coil secondary which is strong enough to bridge gap on spark plug. Each coil fires every other revolution (during normal running).

ETB EFI engines are equipped with either a 20 amp or high output charging system to accommodate combined electrical demands of ignition system and specific application. Charging system troubleshooting information is provided in Electrical System.

An electric fuel pump module and a lift pump are used to transfer fuel in EFI system. Types of lift pumps are: a pulse fuel pump, a mechanical fuel pump, or a low pressure electric fuel pump. Pumping action is created by either oscillation of positive and negative pressures within crankcase through a hose, or by direct lever/pump actuation off rocker arm movement. Pumping action causes diaphragm on inside of pump to pull fuel in on its downward stroke and to push it into fuel pump module on its upward stroke. Internal check valves prevent fuel from going backward through pump. Fuel pump module receives fuel from lift pump, increases and regulates pressure for fuel injectors.

Fuel pump module is rated for a minimum output of 13.5 liters (3.51 gallons) per hour and regulated at 270 kilopascals (39 psi).

When key switch is turned ON and all safety switch requirements are met, ECU activates fuel pump module for about six seconds, which pressurizes system for start-up. If key switch is not promptly turned to start position, engine fails to start, or engine is stopped with key switch ON (as in case of an accident), ECU switches off pump preventing continued delivery of fuel. In this situation, MIL will go on, but it will go back off after 4 cranking revolutions if system function is OK. Once engine is running, fuel pump remains on.

Precision components inside fuel pump module are not serviceable. DO NOT attempt to open fuel pump module. Damage to components will result and warranty will be void. Because fuel pump module is not serviceable, engines are equipped with a special 10-micron EFI fuel filter to prevent harmful contamination from entering module.

If there are two filters in system, one before lift pump will be a standard 51-75 micron filter, and one after lift pump will be special 10-micron filter. Be sure to use an approved 10-micron filter for replacement.

EFI SYSTEM-ELECTRONIC THROTTLE BODY (ETB) ECH

High pressure fuel line is an assembly of hoses, injector caps and a fuel connector to fuel pump module. High pressure fuel line feeds fuel to top of injectors through injector caps. Caps are fastened to intake manifold and injectors are locked into place. A small retaining clip provides a secondary lock.

High pressure fuel line is serviced as a complete assembly to prevent tampering and safety hazards. Components are not individually serviceable.

Vent hose assembly is intended to vent fuel vapor out of fuel pump module and direct fuel vapor into electronic throttle body. Most EFI engines are equipped with an engine mounted purge port on #2 cylinder barrel baffle. This capped purge port can be used by OEM to vent fuel tanks or used in conjunction with a carbon canister kit for evaporative emissions compliance. Purge port connects to vent hose assembly and directs all fuel vapor into electronic throttle body. If purge port remains unused, port must remain capped to prevent dirt from entering engine.

EFI engines have no carburetor, so throttle function (regulate incoming combustion airflow) is achieved with a throttle valve in a separate electronic throttle body (ETB) attached to intake manifold. ETB is an assembly of three functional components: 1) A mechanical throttle body to control air flow to engine. 2) A DC electric motor and gear reduction to drive and position throttle blade. 3) A non-contact throttle position sensor to measure throttle position. This technology is common on many modern automobiles, including a return spring feature. Return spring will mechanically return throttle blade to a home position if power is lost or interrupted to drive motor. Home position is above normal low idle position, but typically is low RPM and very low load.

ETB (Electronic throttle body)/intake manifold provides mounting for fuel injectors, throttle position sensor, TMAP sensor, high pressure fuel line, and air cleaner assembly.

ETB Engine idle speed is not adjustable and is preset and controlled by ECU. Standard idle speed setting for EFI engines is 1500 RPM, but certain applications might require a different setting.

For starting and warm up, ECU will adjust fuel and ignition timing, based upon ambient temperature, engine temperature, and loads present. In cold conditions, idle speed will be different than normal for a few moments. Idle speed typically starts higher than normal, but gradually decreases to established setting as operation continues. Engine must be completely warmed up, in closed loop operating mode for accurate idle check.

IMPORTANT NOTES!

- Cleanliness is essential and must be maintained at all times when servicing or working on EFI system. Dirt, even in small quantities, can cause significant problems.
- Clean any joint or fitting with parts cleaning solvent before opening to prevent dirt from entering system.
- Always depressurize fuel system through fuel connector on fuel pump module before disconnecting or servicing any fuel system components.
- Never attempt to service any fuel system component while engine is running or ignition switch is ON.
- Do not use compressed air if system is open. Cover any parts removed and wrap any open joints with plastic if they will remain open for any length of time. New parts should be removed from their protective packaging just prior to installation.
- Avoid direct water or spray contact with system components.
- Do not disconnect or reconnect ECU wiring harness connector or any individual components with ignition on. This can send a damaging voltage spike through ECU.
- Do not allow battery cables to touch opposing terminals. When connecting battery cables attach positive (+) cable to positive (+) battery terminal first, followed by negative (-) cable to negative (-) battery terminal.
- Never start engine when cables are loose or poorly connected to battery terminals.
- Never disconnect battery while engine is running.
- Never use a quick battery charger to start engine.
- Do not charge battery with key switch ON.
- Always disconnect negative (-) battery cable before charging battery, and also unplug harness from ECU before performing any welding on equipment.

EFI SYSTEM-ELECTRONIC THROTTLE BODY (ETB) ECH

ELECTRICAL COMPONENTS

Electronic Control Unit (ECU)

Pinout of ECU

Black Connector Side	
Pin #	Description
1	Ignition Coil #1 Ground
2	Battery Ground
3	Not Used
4	Crankshaft Position Sensor Input High
5	Fuel Injector Output #1 Ground
6	Fuel Injector Output #2 Ground
7	Oxygen Sensor Heater
8	Intake Air Temperature (TMAP) Sensor Input
9	Fuel Pump Ground
10	Ground for TPS, TMAP, O2, and Temp sensors
11	Manifold Absolute Pressure (TMAP) sensor input
12	Throttle Position Sensor (TPS) input
13	Crankshaft Position Sensor Low
14	Engine Temperature Sensor input
15	Ignition Switch (Switched +12V)
16	Power for TPS and TMAP sensor (+5V)
17	Oxygen Sensor (O2) input
18	Battery Power (Permanent +12V)

Grey Connector Side	
Pin #	Description
1	Not Used
2	Not Used
3	Malfunction Indicator Light (MIL) Ground
4	Not Used
5	Not Used
6	Not Used
7	CAN Low
8	CAN High
9	Battery Ground
10	Ignition Coil #2 Ground
11	ETB Motor High
12	ETB Motor Low
13	Desired Engine Speed Input (0-5V)
14	Safety Switch Ground
15	Not Used
16	ECU Reset
17	Fuel Pump Control (+12V)
18	Not Used

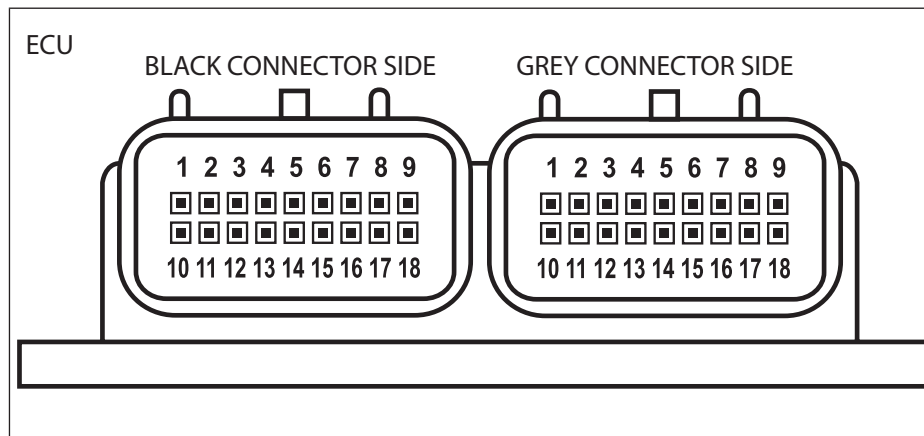

Pinout of ECU

EFI SYSTEM-ELECTRONIC THROTTLE BODY (ETB) ECH

Never attempt to disassemble ECU. It is sealed to prevent damage to internal components. Warranty is void if case is opened or tampered with in any way.

All operating and control functions within ECU are preset. No internal servicing or readjustment may be performed. If a problem is encountered, and you determine ECU to be faulty, contact your source of supply.

ECU pins are coated at factory with a thin layer of electrical grease to prevent fretting and corrosion. Do not attempt to remove grease from ECU pins.

Relationship between ECU and throttle position sensor (TPS) is very critical to proper system operation. TPS to throttle shaft positioning is an automated process performed at key cycle and cannot be altered.

Any service to ECU, TPS/Electronic Throttle Body, or fuel pump module replacement should include ECU Reset.

This will clear all trouble codes, all closed loop learned offsets, all max values, and all timers besides permanent hour meter.

This system will NOT reset when battery is disconnected!

ECU Reset Procedure

1. Turn key/ignition OFF.
2. Install Green colored wire jumper from Rehlko EFI service kit on to diagnostic port (or connect white wire to black wire (terminals G and E) in diagnostic port).
3. Turn key/ignition ON, then OFF and count 10 seconds.
4. Turn key/ignition ON, then OFF and count to 10 seconds a second time.
5. Remove Green colored wire jumper. Turn key/ignition ON, then OFF and count to 10 seconds a third time. ECU is reset.

EFI SYSTEM-ELECTRONIC THROTTLE BODY (ETB) ECH

ETB EFI Wiring Harness 20 Amp

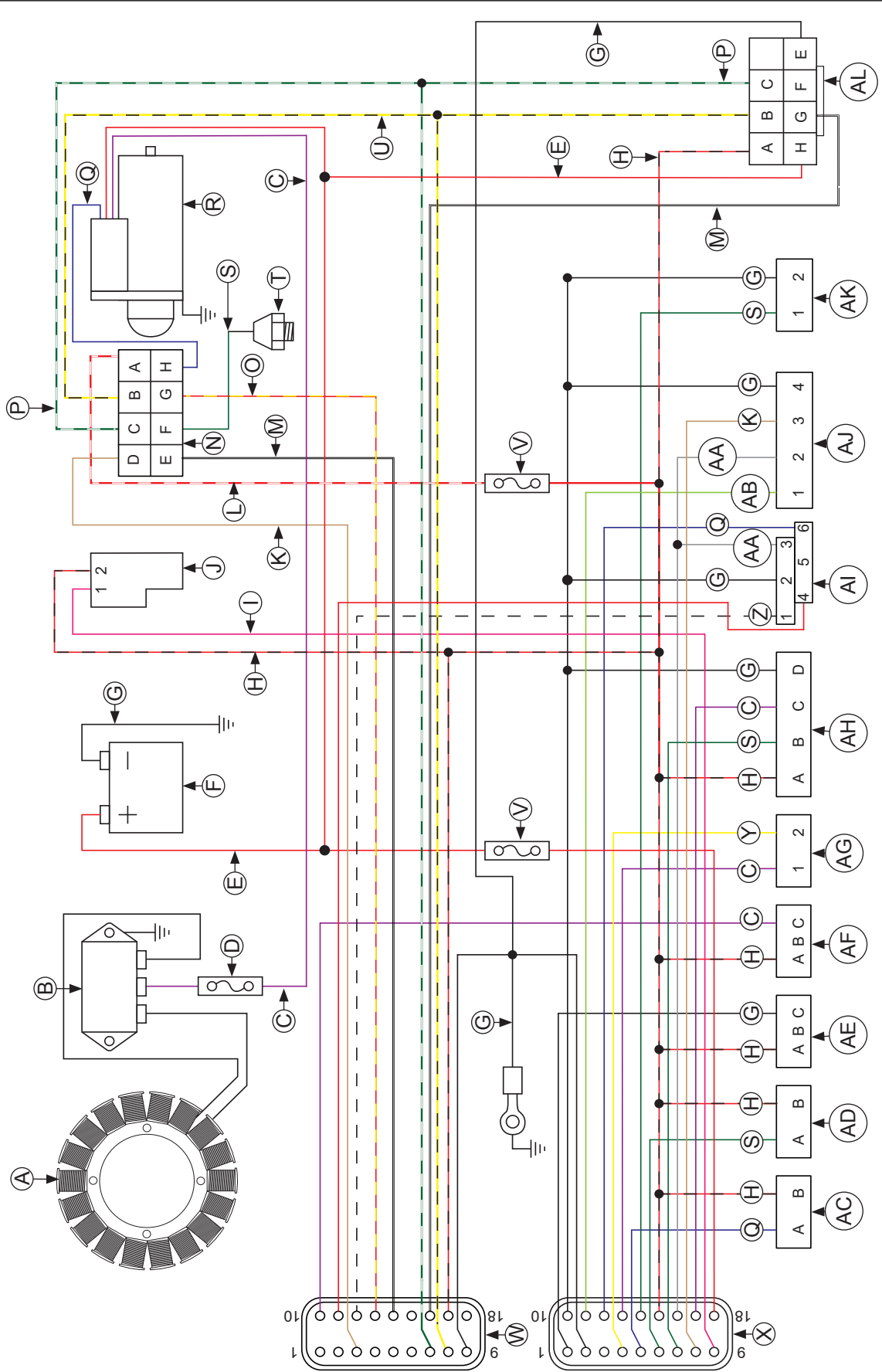

EFI SYSTEM-ELECTRONIC THROTTLE BODY (ETB) ECH

ETB EFI Wiring Harness 20 Amp Detail							
A	Stator	B	Rectifier-Regulator	C	Purple	D	30A Fuse
E	Red	F	Battery	G	Black	H	Red/Black
I	Pink	J	Fuel Pump Module	K	Tan	L	Red/White
M	White	N	8-Terminal Connector	O	Red/Yellow	P	Green/White
Q	Dark Blue	R	Starter Motor	S	Dark Green	T	Oil Pressure Switch
U	Yellow/Black	V	10A Fuse	W	Grey Connector	X	Black Connector
Y	Yellow	Z	Black/White	AA	Grey	AB	Light Green
AC	Fuel Injector #1	AD	Fuel Injector #2	AE	Ignition Coil #1	AF	Ignition Coil #2
AG	Crankshaft Position Sensor	AH	Oxygen Sensor	AI	Electronic Throttle Body	AJ	TMAP Sensor
AK	Engine Temperature Sensor	AL	Diagnostic Connector (8 Bay, 7 Pin)				

EFI SYSTEM-ELECTRONIC THROTTLE BODY (ETB) ECH

ETB EFI with Analog Speed Control Wiring Harness* 20 Amp Detail with Key Switch (w/Jumper Harness)

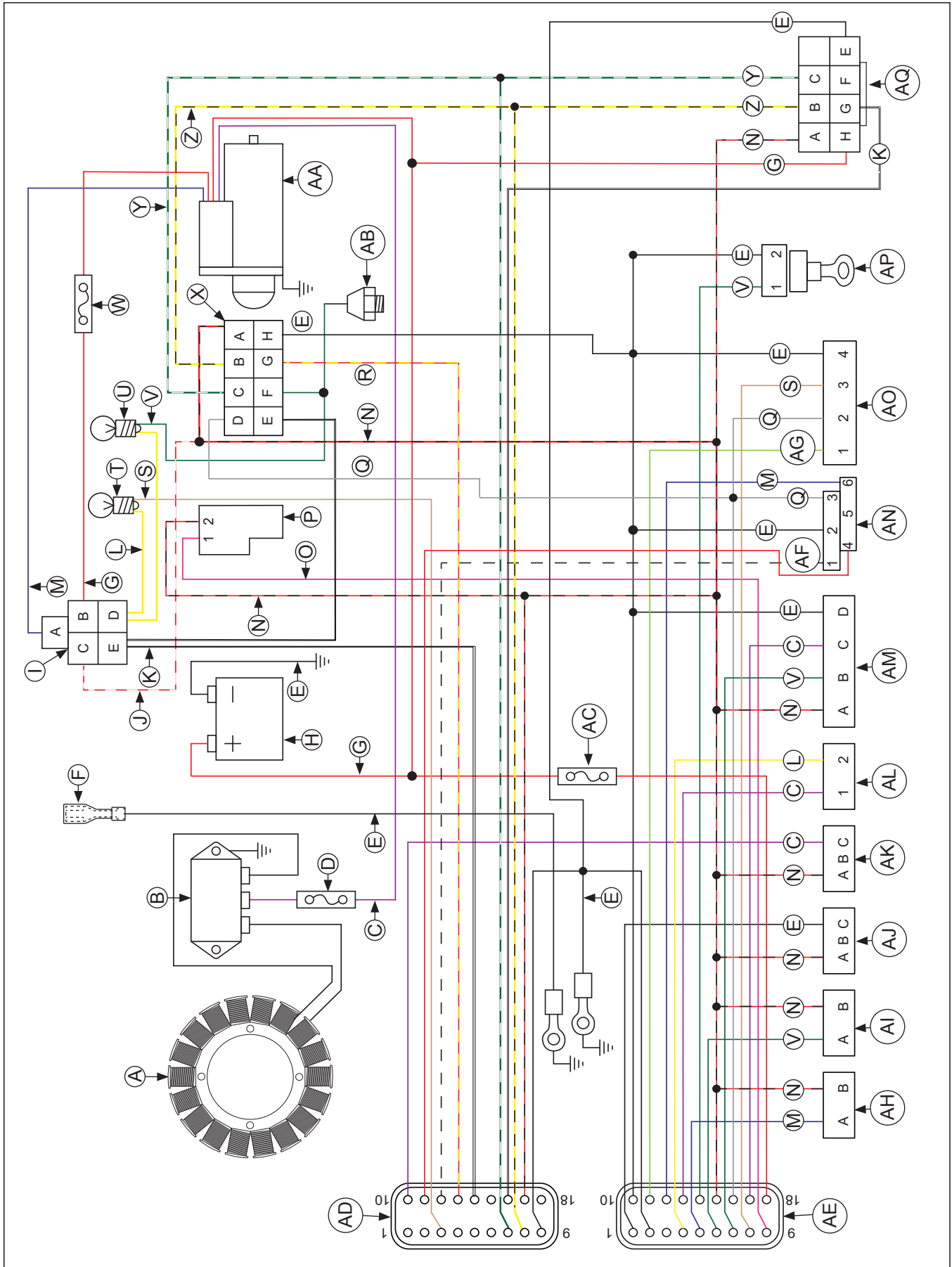

EFI SYSTEM-ELECTRONIC THROTTLE BODY (ETB) ECH

ETB EFI with Analog Speed Control Wiring Harness* 20 Amp Detail with Key Switch (w/Jumper Harness)							
A	Stator	B	Rectifier-Regulator	C	Purple	D	30A Fuse
E	Black	F	Key Switch Ground	G	Red	H	Battery
I	5-Terminal Connector	J	Red/White	K	White	L	Yellow
M	Dark Blue	N	Red/Black	O	Pink	P	Fuel Pump Module
Q	Grey	R	Red/Yellow	S	Tan	T	MIL
U	Oil Light	V	Dark Green	W	10A Fuse (Switched Power)	X	8-Terminal Connector
Y	Green/White	Z	Yellow/Black	AA	Starter Motor	AB	Oil Pressure Switch
AC	10A Fuse (Battery Power)	AD	Grey Connector	AE	Black Connector	AF	Black/White
AG	Light Green	AH	Fuel Injector #1	AI	Fuel Injector #2	AJ	Ignition Coil #1
AK	Ignition Coil #2	AL	Crankshaft Position Sensor	AM	Oxygen Sensor	AN	Electronic Throttle Body
AO	TMAP Sensor	AP	Engine Temperature Sensor Lead	AQ	Diagnostic Connector (8 Bay, 7 Pin)		

*This main engine wiring harness will have an attached, application specific, 8-terminal jumper harness that connects to application chassis harness. This main engine harness is not intended for use without this jumper harness.

NOTE: Do not attempt to make a connection to this main harness 8-terminal connector without jumper harness. Failure to use this supplied jumper may damage ECU.

Jumper Harness (Must be used with ETB EFI with Analog Speed Control Wiring Harness)							
A	8-Terminal Connector (Plugs into Wiring Harness 8-Terminal Connector)	B	Red/Yellow	C	Desired Speed	D	Dark Green
E	Oil Pressure Sensor (Plugs into H)	F	White	G	Customer Connector for Engine Kill	H	Kills Engine if Low Oil Pressure (Plugs into E)
I	Grey	J	5 V Out Covered	K	Red/White	L	12 V Switched Power

Engines equipped with this jumper harness feature ETB-Analog speed control. Engine speed is adjusted using variable voltage inputs received by ECU from OEM controller.

Voltage signal range is 0 to 5 volts max. Idle = 0 (zero) volts. Max high speed = 5 (five) volts.

Any voltage between these two values yields a different speed within range. If throttle system does not respond to commands use these steps to test system.

Disconnect jumper terminal C (red/yellow wire) from OEM harness. Remove cover from jumper terminal J (grey wire tied back). Start engine (idle approx. 1500 RPM), connect jumper terminals C and J together. Engine speed should increase to high speed (approx. 3900 RPM).

If speed DOES increase, problem is with OEM control system. Consult OEM service information for OEM diagnostics.

If speed DOES NOT increase, problem is with engine ETB system. This can be tested using Rehlko Diagnostic System (KDS) Gen 2, see Tools and Aids. Select Throttle Position Test and follow instructions in help (?) area of test.

EFI SYSTEM-ELECTRONIC THROTTLE BODY (ETB) ECH

ETB EFI Wiring Harness High Output Charging System

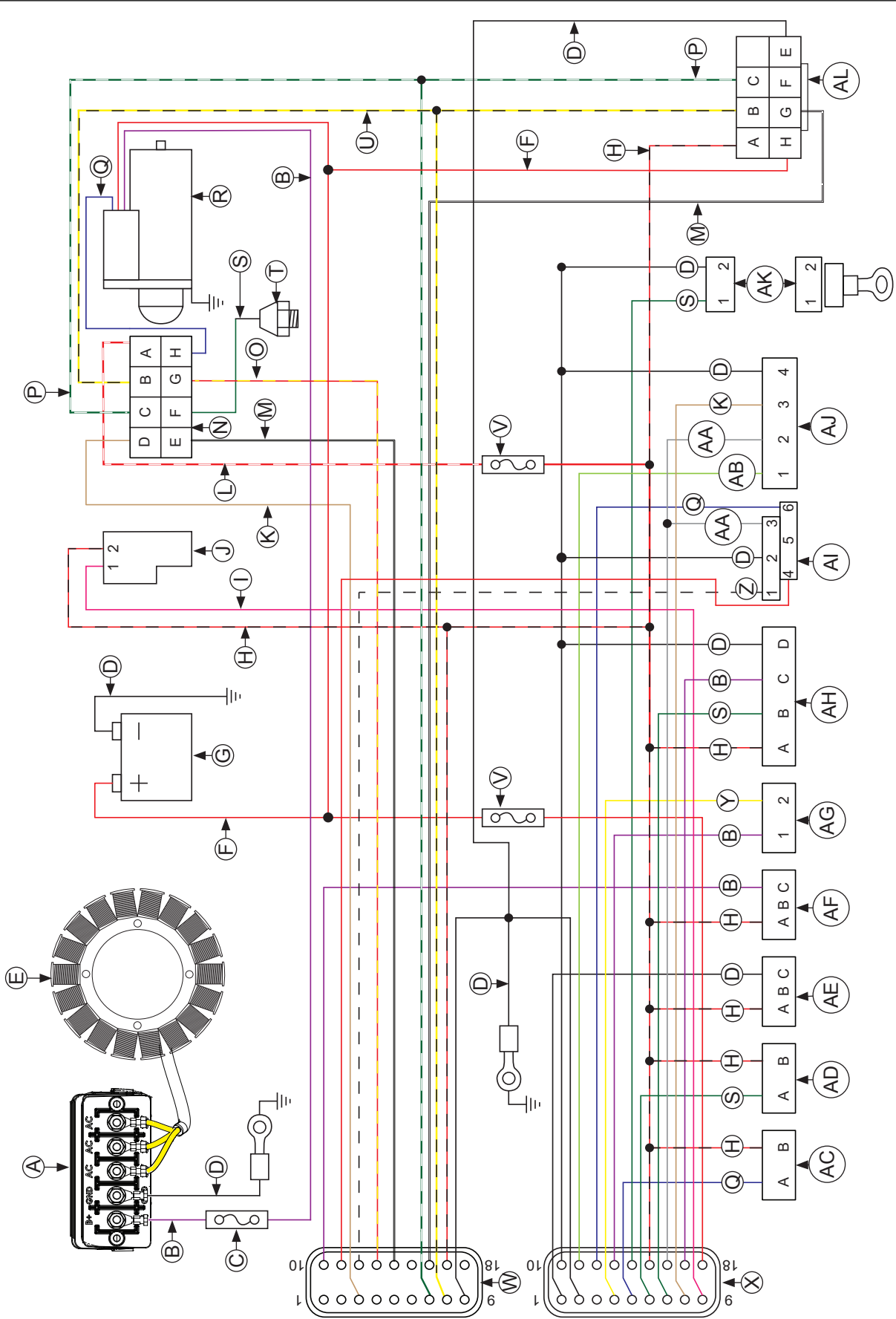

EFI SYSTEM-ELECTRONIC THROTTLE BODY (ETB) ECH

ETB EFI Wiring Harness High Output Charging System Detail							
A	Rectifier-Regulator	B	Purple	C	Rehiko 60A Fuse*	D	Black
E	Stator	F	Red	G	Battery	H	Red/Black
I	Pink	J	Fuel Pump Module	K	Tan	L	Red/White
M	White	N	8-Terminal Connector	O	Red/Yellow	P	Green/White
Q	Dark Blue	R	Starter Motor	S	Dark Green	T	Oil Pressure Switch
U	Yellow/Black	V	10A Fuse	W	Grey Connector	X	Black Connector
Y	Yellow	Z	Black/White	AA	Grey	AB	Light Green
AC	Fuel Injector #1	AD	Fuel Injector #2	AE	Ignition Coil #1	AF	Ignition Coil #2
AG	Crankshaft Position Sensor	AH	Oxygen Sensor	AI	Electronic Throttle Body	AJ	TMAP Sensor
AK	Engine Temperature Sensor (Breather Cover) or Engine Temperature Sensor Lead			AL	Diagnostic Connector (8 Bay, 7 Pin)		

*Main engine harness has 30A fuse, but this fuse is nonfunctional in High Output Charging System, as 30A charging circuit has been disabled.

Crankshaft Position Sensor

A sealed, non-serviceable assembly. If fault code P0337 is present and engine does not start/run, proceed to step 1. If P0337 is present and engine operates, clear codes and retest. If Fault Code diagnosis indicates a problem within this area, test and correct as follows.

1. Inspect wiring and connections for damage or problems.
2. Make sure engine has resistor type spark plugs.
3. Disconnect Black connector from ECU.
4. Connect an ohmmeter between #4 and #13 pin terminals. A resistance value of 325-395 Ω at room temperature (20°C, 68°F) should be obtained.
5. If resistance is correct, remove blower housing.
6. Disconnect crankshaft position sensor connector from wiring harness. Test resistance between terminals. A reading of 325-395 Ω should again be obtained.
 - a. If resistance is incorrect, remove screws securing sensor to mounting bracket and replace sensor.
 - b. If resistance in step 4 was incorrect, but resistance of sensor alone was correct, test wire harness circuits between sensor connector terminals and corresponding pin terminals (#4 and #13) in main connector. Correct any observed problem, reconnect sensor, and perform step 4 again.
7. If resistance in step 4 is correct, check mounting, flywheel teeth (damage, run-out, etc.), and flywheel key.
8. When fault is corrected and engine starts, clear fault codes following ECU Reset procedure.

Throttle Position Sensor (TPS)

TPS is a sealed, non-serviceable internal part of electronic throttle body assembly. If diagnosis indicates a bad sensor, complete electronic throttle body replacement is necessary. If a blink code indicates a problem with TPS, it can be tested as follows:

Diagnostics of sensor: ECU will still have electrical faults captured in fault codes: P0122 & P0123. These electrical faults still have same meaning as with prior sensor, P0122 detecting low voltage, open circuit, and P0123 for high voltage conditions between ECU, wire harness, and sensor. Tip: when working with any electrical connection, remember to keep connections clean & dry. This is best accomplished by cleaning connection thoroughly prior to disassembly. Contaminated sensor connections can cause premature engine faults. Functionally testing sensor can no longer be done with simple resistance checks. If either of these two faults is present or a TPS fault is suspected, recommended diagnostic test is as follows:

If Rehiko Diagnostic System (KDS) Gen 2 is available (see Tools and Aids)

Observe throttle percent and raw TPS values through KDS tool. With KDS tool communicating to ECU and key ON engine not running, these values can be observed using Throttle Position test within KDS tool test options. Select Throttle Position Test, select desired percent of throttle opening. (For example, 50% requested opening will yield 50% TPS opening +/- 5%.) It is recommended to perform multiple tests in different throttle opening positions. (For example, 10%, 50%, and 100%.) If any of these tests are found to be outside of specified range, it is recommended to power engine down, wait 15 seconds, turn engine key switch power to ON position, and using KDS tool, repeat Throttle Opening Test. If values again are found to be outside of specified range, it is recommended to replace electronic throttle body assembly. If no results are found while performing this test, a small load or gentle back and forth motion can be applied to connectors or wires just outside connectors to detect a faulty connection.

EFI SYSTEM-ELECTRONIC THROTTLE BODY (ETB) ECH

If only a volt meter is available

Measure voltage supply to sensor from ECU. This voltage should be 5.00 +/- 0.20 volts. This can be measured by gently probing terminals 2 & 3 on harness side with TPS connector removed from TPS and key ON. This will generate a P0122 fault that can be cleared with an ECU reset. If voltage is low, battery, harness and ECU should be investigated. If supply voltage is good, plug sensor back into harness. Probe sensor signal wire with volt meter, terminal 6 at TPS or pin Black 12 at ECU. This signal should be 0.6-1.2 volts at idle. Since there is no longer any wear elements inside sensor, most likely faults will be in electrical connections between sensor and wire harness and wire harness to ECU.

Engine Temperature Sensor or Engine Temperature Sensor Lead

Engines will have either a sensor mounted in breather cover or a sensor lead that secures on #2 cylinder valley baffle closest to exhaust port. Follow test procedure for design on engine being serviced.

Engine Temperature Sensor (Breather Cover)

A sealed, non-serviceable assembly. A faulty sensor must be replaced. If a blink code indicates a problem with temperature sensor, it can be tested as follows:

1. Remove temperature sensor from breather cover and cap or block sensor hole.
2. Wipe sensor clean and allow it to reach room temperature (25°C, 77°F).
3. Unplug Black connector from ECU.
4. With sensor still connected, check temperature sensor circuit resistance between Black pin 10 and 14 terminals. Value should be 9000-11000 Ω.
5. Unplug sensor from wire harness and check sensor resistance separately across two pins. Resistance value should again be 9000-11000 Ω.
 - a. If resistance is out of specifications, replace temperature sensor.
 - b. If it is within specifications, proceed to Step 6.
6. Check circuits (input, ground), from wire harness connector to sensor plug for continuity, damage, etc. Connect one ohmmeter lead to Black pin 14 in wire harness connector (as in step 4). Connect other lead to terminal #1 in sensor plug. Continuity should be indicated. Repeat test between Black pin 10 and terminal #2 in sensor plug.

Engine Temperature Sensor Lead

A sealed, non-serviceable assembly. A faulty sensor must be replaced. If a blink code indicates a problem with temperature sensor, it can be tested as follows:

1. Remove screw securing temperature sensor lead on #2 valley baffle. If another bracket is secured with this same screw, note that sensor lead is between them.
2. Allow sensor to reach room temperature (25°C, 77°F).
3. Unplug Black connector from ECU.
4. With sensor still connected, check temperature sensor circuit resistance between Black pin 10 and 14 terminals. Value should be 9800-10200 Ω.

5. Unplug sensor from wire harness and check sensor resistance separately across two pins. Resistance value should again be 9800-10200 Ω.
 - a. If resistance is out of specifications, replace temperature sensor lead.
 - b. If it is within specifications, proceed to Step 6.
6. Check circuits (input, ground), from wire harness connector to sensor plug for continuity, damage, etc. Connect one ohmmeter lead to Black pin 14 in wire harness connector (as in step 4). Connect other lead to terminal #1 in sensor plug. Continuity should be indicated. Repeat test between Black pin 10 and terminal #2 in sensor plug.

Temperature/Manifold Absolute Pressure (TMAP) Sensor

A sealed non-serviceable integrated sensor that checks both intake air temperature and manifold absolute pressure. Complete replacement is required if it is faulty. Sensor and wiring harness can be checked as follows.

If a blink code indicates a problem with Intake Air Temperature (TMAP) Sensor Circuit (P0112 or P0113), it can be tested as follows:

1. Remove TMAP sensor from intake manifold.
2. Allow it to reach room temperature (20°C, 68°F).
3. Unplug Black connector from ECU.
4. With sensor still connected, check temperature sensor circuit resistance between Black pin 10 and 8 pin terminals. Value should be 1850-2450 Ω.
5. Unplug sensor from wire harness and check sensor resistance separately across pin. Resistance value should again be 1850-2450 Ω.
 - a. If resistance is out of specifications, check local temperature. Sensor resistance will go down as temperature is higher. Replace TMAP sensor if determined to be faulty.
 - b. If it is within specifications, proceed to Step 6.
6. Check circuits (input, ground), from main harness connector to sensor plug for continuity, damage, etc. Connect one ohmmeter lead to Black pin 8 in main harness connector (as in step 4). Connect other lead to terminal #3 in sensor plug. Continuity should be indicated. Repeat test between Black pin 10 and terminal #4 in sensor plug.
7. Reinstall sensor.

If a blink code indicates a problem with Manifold Absolute Pressure (TMAP) Sensor Circuit (P0107 or P0108), it can be tested as follows:

1. Make sure all connections are making proper contact and are free of dirt and debris. Slide locking tab out and pull off TMAP connector. Turn key switch to ON and check with a volt meter by contacting red lead to pin 1 and black lead to pin 2. There should be 5 volts present, indicating ECU and wiring harness are functioning.
2. Check continuity in wire harness. Ohms between Pin 3 at sensor connector and Black pin 11 connector at ECU should be near zero ohms. If no continuity is measured or very high resistance, replace wire harness.

EFI SYSTEM-ELECTRONIC THROTTLE BODY (ETB) ECH

3. Check to make sure intake manifold is not loose and TMAP sensor is not loose. Loose parts would allow a vacuum leak, making TMAP sensor report misleading information to ECU.
 - a. Tighten all hardware and perform an ECU Reset Procedure to see if MIL will display a fault with sensor again. If MIL finds a fault with TMAP sensor, replace it.

Oxygen Sensor (O2)

Identify style of sensor to ensure proper testing and installation torque.

Style 1 (Smaller Sensor)

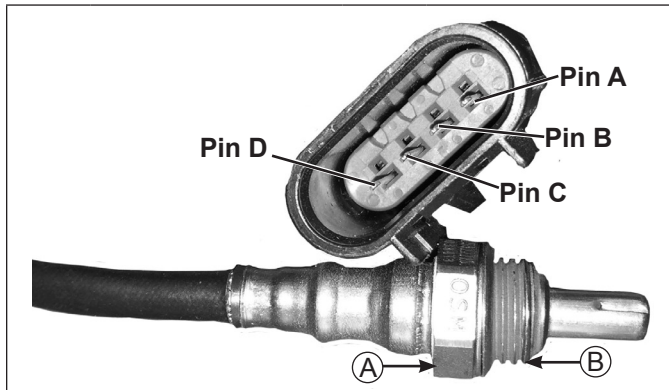

Pin A	Heater +	Pin B	Heater -
Pin C	Sensor Output	Pin D	Sensor Ground
A	14 mm or 9/16 in. Wrench Size	B	12 mm x 1.25 Thread Size
Installation Torque 18 N·m (159 in. lb.)			

Style 2 (Larger Sensor)

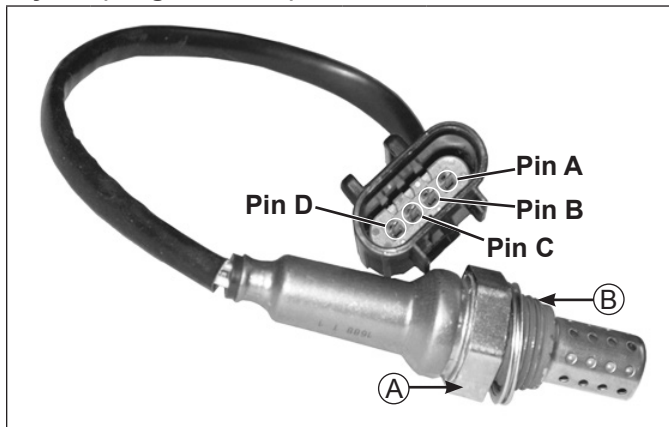

Pin A	Heater +	Pin B	Heater -
Pin C	Sensor Output	Pin D	Sensor Ground
A	22 mm or 7/8 in. Wrench Size	B	18 mm x 1.5 Thread Size
Installation Torque 50.1 N·m (37 ft. lb.)			

Cutaway Oxygen Sensor Components (O2)

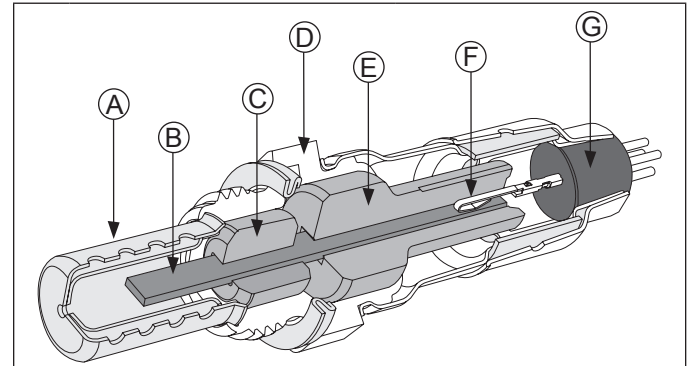

A	Protection Shield	B	Planar Element and Heater
C	Lower Insulator	D	Stainless Steel Housing
E	Upper Insulator	F	Terminal Connection to Element
G	High Temp Water Seal		

Temperature must be controlled very accurately and gas constituents measured to a high degree of accuracy for absolute sensor measurements. This requires laboratory equipment to determine a good or bad sensor in field. Furthermore, as with most devices, intermittent problems are difficult to diagnose. Still, with a good understanding of system and sensor, it is possible to diagnose many sensor problems in field.

Using Rehlko Diagnostic System (KDS) Gen 2, see Tools and Aids, connected to ECU is a useful technique for observing sensor performance. However, user must understand that such software reads a signal generated by ECU. If there is an ECU or wiring problem, readings could be misinterpreted as a sensor problem. Digital nature of signal to KDS tool means that it is not reading continuous output of sensor. A voltmeter can also be used as an effective tool in diagnosing sensors.

Using injector timing test within KDS tool will aid in testing operation of O2 sensor. See instructions within help (?) area of injector timing test.

It is advisable to use an electronic meter such as a digital voltmeter. Simple mechanical meters may place a heavy electrical load on sensor and cause inaccurate readings. Since resistance of sensor is highest at low temperatures, such meters will cause largest inaccuracies when sensor is in a cool exhaust.

EFI SYSTEM-ELECTRONIC THROTTLE BODY (ETB) ECH

Visual Inspection Sensor Wire Detail

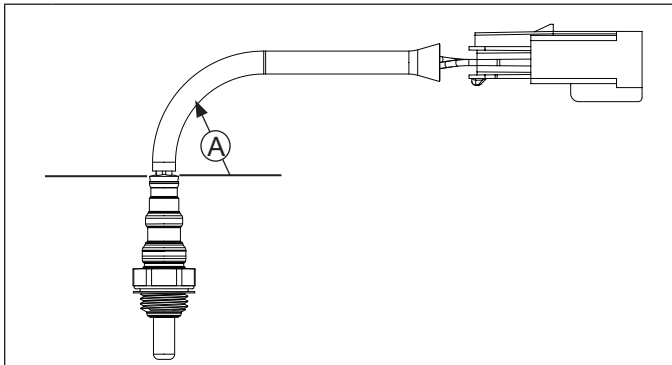

A Keep a minimum of 25 mm (1.0 in.) radius at grommet.

NOTE: Always route harness away from hot exhaust and away from moving parts.

NOTE: **Do not attempt to clean sensor.** Replace as needed.

1. Look for a damaged or disconnected sensor-to-engine harness connection.
2. Look for damage to sensor lead wire or associated engine wiring due to cutting, chaffing or melting on a hot surface.
3. Disconnect sensor connector and look for corrosion in connector.
4. Try reconnecting sensor and observe if problem has cleared.
5. Correct any problems found during visual check.
6. Inspect for any exhaust system leaks upstream or downstream of oxygen sensor. Confirm oxygen sensor is secured to exhaust with appropriate torque.
 Style 1 (Smaller Sensor) 18 N·m (159 in. lb.).
 Style 2 (Larger Sensor) 50.1 N·m (37 ft. lb.).
 All leaks must be repaired and an ECU reset must be performed before proceeding with sensor testing.
7. Using KDS tool, document any trouble codes. Determine if historic trouble codes are logically related to current fault experienced. If uncertain, clear codes and retest.

Sensor Signal Observation Engine Harness O2 Sensor Connector Plug Detail

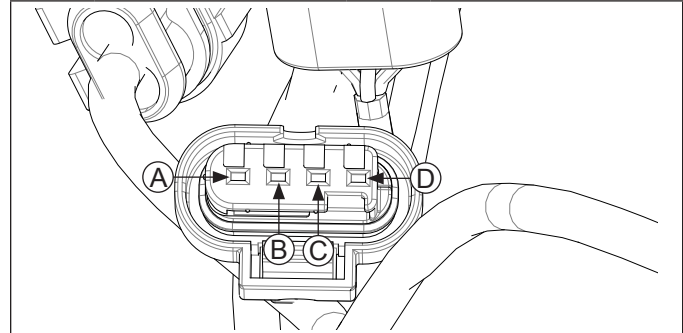

A	Red w/Black Stripe	B	Dark Green
C	Purple	D	Black

NOTE: **Do not cut into or pierce sensor or engine wiring to make this connection.** Sensor produces a very small signal. Corrosion or damage to wiring could lead to an incorrect signal because of repairs or contamination to sensor.

1. With sensor connected and using Rehlko Diagnostic System (KDS) Gen 2, see Tools and Aids, start engine to observe O2 sensor activity. Run engine at sufficient speed to bring sensor and engine up to operating temperature (engine temperature of 150°F (66°C) or more displayed by KDS tool).
 Maintained throttle openings of less than 20% typically display closed loop operation where sensor output voltage should cycle between 0.05 to 0.95 Volts.
 Maintained throttle openings of 30-40% and above typically display open loop operation where sensor should have above 0.500 Volt. Occasional spikes outside these values is normal. Lack of continuous fluctuation is not an indication of a defective sensor.
2. With key ON and engine OFF, sensor connected, using diagnostic software, O2 volts displayed should be more than 1.0 volt. This voltage is generated by ECU. If not present, there may be a power and/or ground supply fault to engine harness or ECU, a fault of engine harness itself (refer to Visual Inspection), or a fault of ECU.
 With key ON and sensor unplugged, using a digital voltmeter, observe voltage between Pin socket C and Pin socket D of engine wiring harness (refer to engine harness connector plug detail at top of page). Voltage should read approximately 5.0 volts.
3. Using a digital voltmeter, observe system sensor voltage between Pin socket A and negative (-) battery ground. Battery voltage should be seen. If battery voltage is not seen, inspect engine wiring, fuses, and/or electrical connections.

EFI SYSTEM-ELECTRONIC THROTTLE BODY (ETB) ECH

Sensor Removal Inspection

NOTE: Apply anti-seize compound only to threads. **Anti-seize compound will affect sensor performance if it gets into lower shield of sensor.**

1. If sensor has heavy deposits on lower shield, engine, oil, or fuel may be source.
2. If heavy carbon deposits are observed, incorrect engine fuel control may be occurring.
3. With sensor at room temperature measure heater circuit resistance, Heater + (Pin A) and Heater - (Pin B).
Style 1 (Smaller Sensor) resistance should be 16.5-19.5 Ω .
Style 2 (Larger Sensor) resistance should be 8.1-11.1 Ω .
4. If a damaged sensor is found, identify root cause, which may be elsewhere in application. Refer to Troubleshooting-Oxygen (O₂) Sensor table.
5. A special "dry to touch" anti-seize compound is applied to all new oxygen sensors at factory. If recommended mounting thread sizes are used, this material provides excellent anti-seize capabilities and no additional anti-seize is needed. If sensor is removed from engine and reinstalled, anti-seize compound should be reapplied. Use an oxygen sensor safe type anti-seize compound. It should be applied according to directions on label. Torque sensor to appropriate torque.
Style 1 (Smaller Sensor) 18 N·m (159 in. lb.).
Style 2 (Larger Sensor) 50.1 N·m (37 ft. lb.).



EFI SYSTEM-ELECTRONIC THROTTLE BODY (ETB) ECH

Troubleshooting-Oxygen (O2) Sensor

Condition	Possible Cause	Conclusion
<p>Continuous low voltage output (less than 400mV) observed with throttle openings of 40% or more (lean biased condition).</p> <p>Fault codes P0131, P0171, or P0174 may set.</p>	Shorted sensor or sensor circuit. Shorted lead wire. Wiring shorted to ground.	Replace sensor or replace and properly route wiring.
	Upstream or downstream exhaust leaks observed. Air leak at sensor.	Repair all exhaust leaks and torque sensor to appropriate torque. Style 1 (Smaller Sensor) 18 N·m (159 in. lb.). Style 2 (Larger Sensor) 50.1 N·m (37 ft. lb.).
	Restricted fuel supply.	Resolve fuel supply issues from tank to engine. Test fuel pressure. Perform repairs necessary.
	Misfire	A misfire causing incomplete combustion will result in lean (low voltage) values.
	Lean biased sensor failure.	Replace sensor.
<p>Continuous high voltage output (600mV or more) observed with throttle openings of 40% or less (rich biased condition).</p> <p>Fault codes P0172 or P0132 may set.</p>	Silica poisoning.	Replace sensor. Identify and resolve root cause.
	Contaminated gasoline.	Purge fuel system and retest.
	Wiring shorted to voltage.	Replace damaged harness.
	Overly rich condition due to unmetered fuel entering combustion chamber.	Test fuel pressure. Inspect fuel pump vent and evaporative emissions hoses for raw fuel flow. Inspect engine oil for fuel contamination; drain and refill if suspect. Perform repairs as necessary.
	Cold engine. Engine temperature below 150°F (66°C) as displayed by Rehlko Diagnostic System (KDS) Gen 2, see Tools and Aids.	Normal operation, or engine operated in an excessively cold environment.
<p>No activity from sensor.</p> <p>KDS tool displays 1.015 Volts continuously.</p> <p>Fault codes P0031 or P0032 may set.</p>	Rich biased sensor failure.	Replace sensor.
	Heater circuit open or shorted.	Replace sensor.
	Engine keyed ON with sensor disconnected. Historic codes.	Secure and/or confirm sensor connection and clear codes.
	Contaminated gasoline.	Purge fuel system and retest.

EFI SYSTEM-ELECTRONIC THROTTLE BODY (ETB) ECH

Fuel Injectors

	 WARNING
	<p>Explosive Fuel can cause fires and severe burns.</p> <p>Fuel system ALWAYS remains under HIGH PRESSURE.</p>
<p>Wrap a shop towel completely around fuel pump module connector. Press release button(s) and slowly pull connector away from fuel pump module allowing shop towel to absorb any residual fuel in high pressure fuel line. Any spilled fuel must be completely wiped up immediately.</p>	

Details

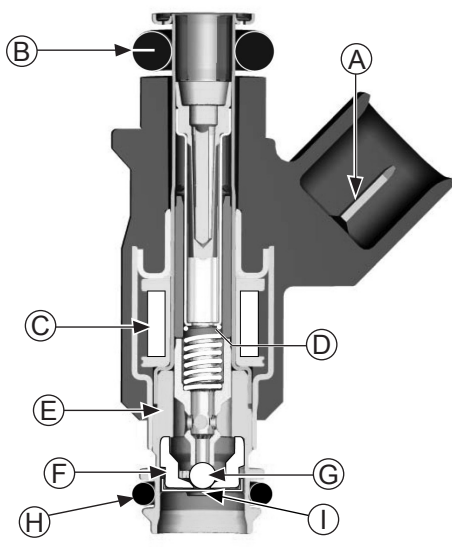

A	Electrical Connection	B	Upper O-ring
C	Solenoid Winding	D	Armature
E	Valve Housing	F	Valve Seat
G	Valve End	H	Lower O-ring
I	Director Plate		

NOTE: Do not apply voltage to fuel injector(s). Excessive voltage will burn out injector(s). Do not ground injector(s) with ignition ON. Injector(s) will open/turn on if relay is energized.

NOTE: When cranking engine with injectors disconnected, fault codes will be registered in ECU and will need to be cleared using software fault clear or an ECU Reset Procedure.

Injector problems typically fall into three general categories: electrical, dirty/clogged, or leakage. An electrical problem usually causes one or both of injectors to stop functioning. Several methods may be used to check if injectors are operating.

1. With engine running at idle, listen for a buzzing or clicking sound.
2. Disconnect electrical connector from an injector and listen for a change in idle performance (only running on one cylinder) or a change in injector noise or vibration.
3. Using Rehlko Diagnostic System (KDS) Gen 2, see Tools and Aids, perform Adjust Injector Timing test or

Injector #1 or #2 test as found in test section of tool. See instructions within help (?) area of each test.

If an injector is not operating, it can indicate either a bad injector, or a wiring/electrical connection problem. Check as follows:

1. Disconnect electrical connector from both injectors. Plug a 12 volt noid light into one connector.
2. Make sure all safety switch requirements are met. Crank engine and check for flashing of test light. Turn key OFF for at least 10 seconds between tests to allow ECU to go to sleep and reawake. Repeat test at other connector.
 - a. If flashing occurs, use an ohmmeter (Rx1 scale) and check resistance of each injector across two terminals. Proper resistance is 11-13 Ω . If injector resistance is correct, check whether connector and injector terminals are making a good connection. If resistance is not correct, replace injector.

Check all electrical connections, connectors, and wiring harness leads if resistance is incorrect.

Injector leakage is very unlikely, but in those rare instances it can be internal (past tip of valve needle), or external (weeping around injector O-rings). Loss of system pressure from leakage can cause hot restart problems and longer cranking times. To check for leakage it will be necessary to loosen or remove blower housing which may involve removing engine from unit. Refer to Disassembly for removal of injector.

1. Remove manifold mounting bolts and separate throttle body/manifold from engine leaving TPS, high pressure fuel line, injectors and fuel line connections intact. Discard old gaskets.
2. Position manifold assembly over an appropriate container to capture fuel and turn key switch ON to activate fuel pump and pressurize system. Do not turn switch to START position.
3. If either injector exhibits leakage of more than two to four drops per minute from tip, or shows any sign of leakage around outer shell, turn ignition switch OFF and replace injector as follows.
4. Depressurize fuel system.
5. Clean any dirt accumulation from sealing/mounting area of faulty injector(s) and disconnect electrical connector(s).
6. Pull retaining clip off top of injector(s). Remove screw holding injector(s) from manifold.
7. Reverse appropriate procedures to install new injector(s) and reassemble engine. Use new O-rings and retaining clips any time an injector is removed (new replacement injectors include new O-rings and retaining clips). Lubricate O-rings lightly with clean engine oil. Use installation tool provided with O-rings to install new upper O-ring. Place tool into fuel injector inlet. Place one side of O-ring into O-ring groove and roll O-ring over tool onto fuel injector. Torque screw securing fuel injector caps and blower housing mounting screws to 7.3 N·m (65 in. lb.), and intake manifold and air cleaner mounting screws to 10.5 N·m (93 in. lb.). An ECU Reset will need to be completed.

EFI SYSTEM-ELECTRONIC THROTTLE BODY (ETB) ECH

Injector problems due to dirt or clogging are generally unlikely due to design of injectors, high fuel pressure, and detergent additives in gasoline. Symptoms that could be caused by dirty/clogged injectors include rough idle, hesitation/stumbling during acceleration, or triggering of fault codes related to fuel delivery. Injector clogging is usually caused by a buildup of deposits on director plate, restricting flow of fuel, resulting in a poor spray pattern. Some contributing factors to injector clogging include higher than normal operating temperatures, short operating intervals, and dirty, incorrect, or poor quality fuel. Cleaning of clogged injectors is not recommended; they should be replaced. Additives and higher grades of fuel can be used as a preventative measure if clogging has been a problem.

Ignition Coil

If a coil is determined to be faulty, replacement is necessary. An ohmmeter may be used to test wiring and coil windings.

NOTE: Do not ground primary coil with ignition ON as they may overheat or spark.

NOTE: Always disconnect spark plug lead from spark plug before performing following tests.

NOTE: **If ignition coil(s) are disabled and an ignition fault is registered, system will automatically disable corresponding fuel injector drive signal.** Fault must be corrected to ignition coil and ECU power (switch) must be turned OFF for 10 seconds for injector signal to return. This is a safety measure to prevent bore washing and oil dilution.

Testing

Using an ohmmeter set on Rx1 scale, check resistance in circuits as follows:

1. To check cylinder coil 1 (starter side), disconnect Black connector from ECU and test between Black pins 1 and 15. To check cylinder coil 2 (oil filter side), disconnect Grey connector from ECU and test between Grey pins 10 and 17. Wiring and coil primary circuits are OK if readings are 0.5-0.8 Ω .
2. If reading(s) are not within specified range, check and clean connections and retest.
3. If reading(s) are still not within specified range, test coils separately from main harness as follows:
 - a. Remove screw retaining coil to housing and disconnect primary leads connector.
 - b. Connect an ohmmeter set on Rx1 scale to primary terminals of coil. Primary resistance should be 0.5-0.8 Ω .
 - c. Connect an ohmmeter set on Rx10K scale between spark plug boot terminal and B+ primary terminal. Secondary resistance should be 6400-7800 Ω .
 - d. If secondary resistance is not within specified range, coil is faulty and needs to be replaced.

Ignition coils can be tested using Rehlko Diagnostic System (KDS) Gen 2, see Tools and Aids. Select Ignition Coil test #1 or #2 and follow instructions in help (?) area of test.

FUEL COMPONENTS

	WARNING
	Explosive Fuel can cause fires and severe burns. Fuel system ALWAYS remains under HIGH PRESSURE.
Wrap a shop towel completely around fuel pump module connector. Press release button(s) and slowly pull connector away from fuel pump module allowing shop towel to absorb any residual fuel in high pressure fuel line. Any spilled fuel must be completely wiped up immediately.	

Fuel Pump Module (FPM)

FPM is not serviceable and must be replaced if determined to be faulty. If a FPM problem is suspected, make certain pump is being activated, all electrical connections are properly secured, fuses are good. If required, testing of fuel pump may be conducted.

FPM can be tested using Rehlko Diagnostic System (KDS) Gen 2, see Tools and Aids. Select Fuel Pump Test and follow instructions in help (?) area of test.

NOTE: Fuel pump module pins are coated with a thin layer of electrical grease to prevent fretting and corrosion. Do not attempt to remove electrical grease from fuel pump module pins.

1. Relieve fuel pressure at FPM. FPM may need to be loosened or pulled away from engine. Press release button(s) and slowly pull connector away from FPM allowing shop towel to absorb any residual fuel in high pressure fuel line. Insert pressure test jumper (from Rehlko EFI Service Kit) between high pressure fuel line and FPM.
2. Connect black hose of Pressure Tester. Route clear hose into a portable gasoline container or equipment fuel tank.
3. Turn on key switch to activate pump and check system pressure on gauge. It may take several key/power down cycles to compress air introduced into system and reach regulated pressure. System pressure of 39 psi \pm 3 should be present. Turn key switch OFF and depress valve button on tester to relieve system pressure.
 - a. If pressure is too high or too low, proceed to troubleshooting.
4. If pump did not activate (step 3), confirm that safety system on equipment is not active. One potential cause of unnecessary FPM replacement may involve measuring voltage at FPM electrical connector. Using a Digital Volt Ohm Meter (DVOM) will provide a reading near battery voltage, even when ECU is not grounding FPM circuit.
 - a. Connect a DVOM across terminals in plug, turn on key switch and confirm battery voltage is present during six second prime process.

EFI SYSTEM-ELECTRONIC THROTTLE BODY (ETB) ECH

- b. Test light confirmation: Turn key off. Disconnect DVOM. Connect 12 volt test light across terminals in plug. Key needs to remain off for a minimum of 30 seconds before proceeding. Turn key on. Confirm test light illuminates for approximately 6 seconds. After approximately 6 seconds, test light will remain off unless another prime cycle is initiated.
5. If battery voltage is not present and/or test light does not illuminate, connect red lead of DVOM to red wire of plug and black lead to a battery ground while key is still ON.
6. If battery voltage is present, turn key switch OFF and connect an ohmmeter between terminals on FPM to check for continuity. If battery voltage at plug was confirmed, and there was continuity across FPM terminals, reconnect plug to FPM, making sure you have a good connection. Turn on key switch and listen for FPM to activate.
 - a. If FPM starts, repeat steps 2 and 3 to verify correct pressure.
 - b. If FPM still does not operate, replace it.
7. If battery voltage was not present at connector inspect fuse and wiring harness.

High Pressure Fuel Line

High pressure fuel line is mounted to intake manifold. No specific servicing is required unless operating conditions indicate that it needs replacement. Thoroughly clean area around all joints and relieve any pressure before starting any disassembly. Detach by removing two mounting screws, wire ties, and injector retaining clips.

Purge Port and Vent Hose Assembly

No specific servicing is required for vent hose assembly or purge port unless operating conditions indicate replacement is required. All components are serviced individually. Abrasion sleeves on hoses should be reused or replaced when servicing vent hoses. Please note vent hose routing and replicate after service or component replacement to prevent pinching or abrasion of vent hoses. Only Rehiko replacement parts can be used because fitting is specific to system and must be maintained. Visit Engines.rehiko.com for recommended Rehiko replacement parts.

Electronic Throttle Body (ETB)/Intake Manifold Assembly

NOTE: ECU Reset is required if electronic throttle body is replaced.

Electronic throttle body (ETB) is serviced as an assembly, with throttle shaft, TPS, and throttle plate installed. Throttle shaft rotates on needle bearings (non-serviceable), capped with seals to prevent air leaks.

ETB can be tested using Rehiko Diagnostic System (KDS) Gen 2, see Tools and Aids. Select Throttle Position Test and follow instructions in help (?) area of test.

TROUBLESHOOTING

Troubleshooting Guide

Condition	Possible Cause
Engine Starts Hard or Fails to Start When Cold.	Fuel pump not running.
	Faulty spark plugs.
	Old/stale fuel.
	Incorrect fuel pressure.
	Crankshaft position sensor loose or faulty.
	TPS set incorrect (ECU Reset).
	TPS faulty.
	Engine temp sensor faulty.
	Faulty coils.
	Low system voltage.
	Faulty injectors.
	Faulty battery.
Loose or corroded connections.	

EFI SYSTEM-ELECTRONIC THROTTLE BODY (ETB) ECH

Troubleshooting Guide

Condition	Possible Cause
Engine Starts Hard or Fails to Start When Hot.	Faulty spark plugs.
	Fuel pump not running.
	Fuel pressure low.
	Insufficient fuel delivery.
	TPS set incorrect (ECU Reset).
	Crankshaft position sensor loose or faulty.
	TPS faulty.
	Engine temp sensor faulty.
	Faulty injectors.
	Vapor lock.
Engine Stalls or Idles Roughly (cold or warm).	Faulty spark plugs.
	Insufficient fuel delivery.
	TPS set incorrect.
	TPS faulty.
	Faulty engine temperature sensor.
Faulty injectors.	
Engine Misses, Hesitates, or Stalls Under Load.	Fuel injector(s), fuel filter, fuel line, or fuel pick-up dirty/restricted.
	Dirty air cleaner.
	Insufficient fuel pressure or fuel delivery.
	Vacuum (intake air) leak.
	Improper governor operation.
	TPS faulty.
Low Power	Bad coil(s), spark plug(s), or wires.
	Faulty/malfunctioning ignition system.
	Dirty air filter.
	Insufficient fuel delivery.
	Plugged/restricted exhaust.
	One injector not working.
	Basic engine problem exists.
	TPS faulty.
Throttle plate in electronic throttle body not fully opening to WOT.	

EFI SYSTEM-ELECTRONIC THROTTLE BODY (ETB) ECH

Function Test

	⚠ WARNING
	<p>High Pressure Fluids can puncture skin and cause severe injury or death.</p> <p>Do not work on fuel system without proper training or safety equipment.</p>
<p>Fluid puncture injuries are highly toxic and hazardous. If an injury occurs, seek immediate medical attention.</p>	

Function of fuel system is to provide sufficient delivery of fuel at system operating pressure of 39 psi ± 3. If an engine starts hard, or turns over but will not start, it may indicate a problem with EFI fuel system. A quick test will verify if system is operating.

1. Disconnect and ground spark plug leads.
2. Complete all safety interlock requirements and crank engine for approximately 3 seconds.
3. Remove spark plugs and check for fuel at tips.
 - a. If there is fuel at tips of spark plugs fuel pump and injectors are operating.
 - b. If there is no fuel at tips of spark plugs, check following:
 1. Make sure fuel tank contains clean, fresh, proper fuel.
 2. Make sure that vent in fuel tank is open.
 3. Make sure fuel tank valve (if equipped) is fully opened.
 4. Make sure battery is supplying proper voltage.
 5. Check that fuses are good, and that no electrical or fuel line connections are damaged or broken.
 6. Test fuel pump module operation as described earlier under Fuel Pump Module.

Fault Codes

Example of Diagnostic Display

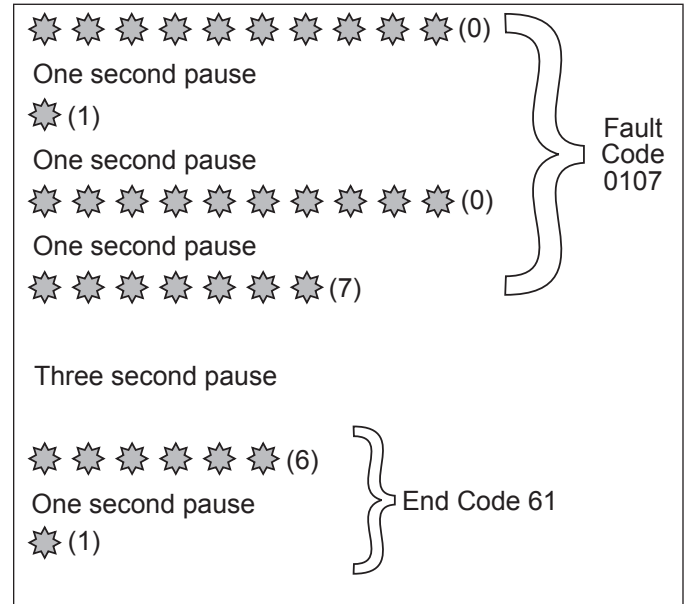

EFI SYSTEM-ELECTRONIC THROTTLE BODY (ETB) ECH

Fault Code Summary

Fault Code	MIL Blinks	Connection or Failure Description	SAE J1939 Fault Codes	
			SPN	FMI
P2119	1/5/2/11	Throttle Actuator Stuck	5419	7
P2100	1/5/2/11	Throttle Actuator Control Motor Circuit Open (Low Current Fault)	5419	5
P0171	1/10/8/13	Maximum Adaptation Limit Exceeded	4237	0
P0172	1/10/8/13	Minimum Adaptation Limit Exceeded	4237	1
P0174	1/10/8/13	Lean Fuel Condition at High Load (Open Loop)	4237	31
P0336	10/2/7/12	Crankshaft Position Sensor Noisy Signal	636	2
P0337	10/2/7/12	False Start Detected/CKP Sensor Signal	636	8
P0201	10/2/8/11	Injector 1 Circuit Malfunction	651	31
P0202	10/2/8/12	Injector 2 Circuit Malfunction	652	31
P0351	10/4/15/4	Cylinder 1 Ignition Coil Malfunction	1268	31
P0352	10/4/15/5	Cylinder 2 Ignition Coil Malfunction	1269	31
P0232	10/5/4/3	Fuel Pump Module Circuit High Voltage	1347	6
P0230	10/5/4/3	Fuel Pump Module Circuit Low Voltage or Open	1347	5
P0123	10/10/3/3	Throttle Position Sensor Circuit High Voltage	51	3
P0122	10/10/3/3	Throttle Position Sensor Circuit Low Voltage or Open	51	4
P0108	10/10/6/6	Manifold Absolute Pressure Sensor Circuit High Voltage	102	3
P0107	10/10/6/6	Manifold Absolute Pressure Sensor Circuit Low Voltage or Open	102	4
P0113	10/10/6/9	Intake Air Temperature Sensor Circuit High Voltage or Open	105	3
P0112	10/10/6/9	Intake Air Temperature Sensor Circuit Low Voltage	105	4
P0118	10/10/6/14	Engine Temperature Sensor Circuit High Voltage or Open	110	3
P0117	10/10/6/14	Engine Temperature Sensor Circuit Low Voltage	110	4
P0217	10/10/6/14	Overheat	110	0
P0563	10/10/6/8	System Voltage High	168	3
P0562	10/10/6/8	System Voltage Low	168	4
P0132	10/11/15/10	Oxygen Sensor 1 Circuit High Voltage	3056	3
P0131	10/11/15/10	Oxygen Sensor 1 Circuit Low Voltage, or Open	3056	4
P0031	10/11/15/10	Oxygen Sensor Heater Circuit Low Voltage	3056	5
P0032	10/11/15/10	Oxygen Sensor Heater Circuit High Voltage	3056	6
61	-	End of Code Transmission	-	-

ECU continuously monitors engine operation against preset performance limits. If operation is outside limits, ECU activates MIL, if equipped, and stores a diagnostic code in its fault memory. If component or system returns to proper function, ECU will turn off MIL. If MIL stays illuminated, it warns customer a fault is currently happening, and dealer service is required. Upon receipt, dealer technician can access fault code(s) to help determine what portion of system is malfunctioning.

Codes are accessed through key switch and displayed as blinks or flashes of MIL. Access codes as follows:

1. Check that battery voltage is above 11 volts.
2. Start with key switch OFF.
3. Turn key switch to ON and OFF, then ON and OFF, then ON, leaving it on in third sequence. Do not start engine. Time between sequences must be less than 2.5 seconds.
4. MIL will blink a series of times. Number of times MIL blinks represents a number in blink code.

5. A sequence of four MIL blinks make up a fault code. There is a one (1) second pause between blinks of a fault code. There is a three (3) second pause between separate fault codes. After fault code(s) are blinked a two digit 61 is blinked to indicate program has completed.

- a. It's a good idea to write down codes as they appear, as they may not be in numerical sequence.
- b. Code 61 will always be last code displayed, indicating end of code transmission. If code 61 appears immediately, no other fault codes are present.

After problem has been corrected, fault codes may be cleared by following ECU Reset Procedure.

Fault Code Summary lists fault codes, and what they correspond to. Diagnostic Code Summary is a list of individual codes with an explanation of what triggers them, what symptoms might be expected, and probable causes.

EFI SYSTEM-ELECTRONIC THROTTLE BODY (ETB) ECH

MIL may not be provided with engine. If equipment manufacturer has not added a MIL to equipment, one can be added easily for quick diagnostics. Main engine to vehicle connection will have a tan wire which is ground for MIL. Either incandescent or LED type bulbs can be used for MIL as long as they do not draw more than 0.1 amps. Bulb needs to be rated at 1.4 Watts or less, or needs to have a total resistance of 140 Ω or more. LEDs typically draw less than 0.03 amps. Attach +12 volts to positive terminal of bulb and attach ground terminal of bulb to tan wire.

ECU circuit will flow small amount of current. This may dimly illuminate LED type bulb. On is bright. Resistor can be added in series if LED type bulb is used to eliminate glow.

Diagnostic Code Summary

Fault Code	MIL Blinks	SPN	FMI
Code P0031	10/11/15/10	3056	5

NOTE: Codes P0031 and P0032 may have been mistakenly activated by turning key ON with oxygen sensor disconnected. If either code status is inactive, that code may have set during assembly or a previous repair and may not be related to current event. Clear codes and retest to confirm. If code status is active, refer to Oxygen Sensor (O2) earlier in this section, to test and troubleshoot.

Component:	Oxygen Sensor Heater
Fault:	O2S Heater Circuit Low Voltage
Condition:	System voltage too low, open connection or faulty sensor.
Conclusion:	<p>Engine Wiring Harness Related</p> <ul style="list-style-type: none"> ● Pin circuit wiring or connectors. ECU Black pin 7 or broken wire. <p>Oxygen Sensor Related</p> <ul style="list-style-type: none"> ● Sensor connector or wiring problem. <p>Poor system ground from ECU to engine or battery to engine.</p>

Fault Code	MIL Blinks	SPN	FMI
Code P0032	10/11/15/10	3056	6

NOTE: Codes P0031 and P0032 may have been mistakenly activated by turning key ON with oxygen sensor disconnected. If either code status is inactive, that code may have set during assembly or a previous repair and may not be related to current event. Clear codes and retest to confirm. If code status is active, refer to Oxygen Sensor (O2) earlier in this section, to test and troubleshoot.

Component:	Oxygen Sensor Heater
Fault:	O2S Heater Circuit High Voltage
Condition:	System voltage too high, shorted connection or faulty sensor.
Conclusion:	<p>Oxygen Sensor Related</p> <ul style="list-style-type: none"> ● Sensor connector or wiring problem. ● Sensor damaged. ● Pin circuit wiring or connectors at Black 7. <p>ECU Related</p> <ul style="list-style-type: none"> ● ECU-to-harness connection problem.

Fault Code	MIL Blinks	SPN	FMI
Code P0107	10/10/6/6	102	4

Component:	Manifold Absolute Pressure (TMAP)
Fault:	MAP Circuit Low Voltage or Open
Condition:	Intake manifold leak, open connection or faulty sensor.
Conclusion:	<p>TMAP Sensor Related</p> <ul style="list-style-type: none"> ● Sensor malfunction. ● Vacuum leaks from loose manifold or sensor. <p>Wire Harness Related</p> <ul style="list-style-type: none"> ● Poor grounding or open circuit. ● Wire harness and connectors loose, damaged or corroded. ● Pin circuit wiring or connectors at Black 10, 11 and 16.

Fault Code	MIL Blinks	SPN	FMI
Code P0108	10/10/6/6	102	3

Component:	Manifold Absolute Pressure (TMAP)
Fault:	MAP Circuit High Voltage
Condition:	Intake manifold leak, shorted connection or faulty sensor.
Conclusion:	<p>TMAP Sensor Related</p> <ul style="list-style-type: none"> ● Sensor malfunction. ● Vacuum leaks from loose manifold or sensor. <p>Wire Harness Related</p> <ul style="list-style-type: none"> ● Poor grounding. ● Pin circuit wiring or connectors at Black 11.

EFI SYSTEM-ELECTRONIC THROTTLE BODY (ETB) ECH

Fault Code	MIL Blinks	SPN	FMI
Code P0112	10/10/6/9	105	4

Component:	Intake Air Temperature (TMAP)
Fault:	Intake Air Temperature Sensor Circuit Low Voltage
Condition:	Shorted connection, faulty sensor or shorted wire.
Conclusion:	<p>TMAP Sensor Related</p> <ul style="list-style-type: none"> • Sensor wiring or connection. <p>Engine Wiring Harness Related</p> <ul style="list-style-type: none"> • Pin circuits ECU Black pin 10 and Black 8 may be damaged or routed near noisy signal (coils, stator, etc.). • ECU-to-harness connection problem.

Fault Code	MIL Blinks	SPN	FMI
Code P0117	10/10/6/14	110	4

Component:	Engine Temperature Sensor
Fault:	Engine Temperature Sensor Circuit Low Voltage
Condition:	Shorted connection, faulty sensor or shorted wire.
Conclusion:	<p>Temperature Sensor Related</p> <ul style="list-style-type: none"> • Sensor wiring or connection. <p>Engine Wiring Harness Related</p> <ul style="list-style-type: none"> • Pin circuits ECU Black pin 10 and Black 14 may be damaged or routed near noisy signal (coils, stator, etc.). • ECU-to-harness connection problem.

Fault Code	MIL Blinks	SPN	FMI
Code P0113	10/10/6/9	105	3

Component:	Intake Air Temperature (TMAP)
Fault:	Intake Air Temperature Sensor Circuit High Voltage or Open
Condition:	Shorted connection, faulty sensor, broken wire or connection.
Conclusion:	<p>TMAP Sensor Related</p> <ul style="list-style-type: none"> • Sensor wiring or connection. <p>Engine Wiring Harness Related</p> <ul style="list-style-type: none"> • Pin circuits ECU Black pin 10 and 8 may be damaged. • ECU-to-harness connection problem or broken wire.

Fault Code	MIL Blinks	SPN	FMI
Code P0118	10/10/6/14	110	3

Component:	Engine Temperature Sensor
Fault:	Engine Temperature Sensor Circuit High Voltage or Open
Condition:	Shorted connection, faulty sensor, open connection or broken wire.
Conclusion:	<p>Temperature Sensor Related</p> <ul style="list-style-type: none"> • Sensor wiring or connection. <p>Engine Wiring Harness Related</p> <ul style="list-style-type: none"> • Pin circuits ECU Black pin 10 and 14 may be damaged. • ECU-to-harness connection problem or broken wire. <p>System Related</p> <ul style="list-style-type: none"> • Engine is operating above 176°C (350°F) temperature sensor limit.

EFI SYSTEM-ELECTRONIC THROTTLE BODY (ETB) ECH

Fault Code	MIL Blinks	SPN	FMI
Code P0122	10/10/3/3	51	4

Component:	Throttle Position Sensor (TPS)
Fault:	TPS Circuit Low Voltage or Open
Condition:	Open connection, broken wire or faulty sensor.
Conclusion:	<p>TPS Related</p> <ul style="list-style-type: none"> • TPS bad or worn internally. <p>Engine Wiring Harness Related</p> <ul style="list-style-type: none"> • Broken or shorted wire in harness. <ul style="list-style-type: none"> ECU Black pin 10 to TPS pin 1. ECU Black pin 12 to TPS pin 3. ECU Black pin 16 to TPS pin 2. <p>Throttle Body Related</p> <ul style="list-style-type: none"> • Throttle shaft inside TPS worn, broken, or damaged. • Throttle plate loose or misaligned. • Throttle plate bent or damaged allowing extra airflow past, or restricting movement. <p>ECU Related</p> <ul style="list-style-type: none"> • Circuit providing voltage or ground to TPS damaged. • TPS signal input circuit damaged.

Fault Code	MIL Blinks	SPN	FMI
Code P0123	10/10/3/3	51	3

Component:	Throttle Position Sensor (TPS)
Fault:	TPS Circuit High Voltage
Condition:	Shorted connection or faulty sensor.
Conclusion:	<p>TPS Sensor Related</p> <ul style="list-style-type: none"> • Sensor connector or wiring. <p>Throttle Body Related</p> <ul style="list-style-type: none"> • Throttle shaft or bearings worn/ damaged. <p>Engine Wiring Harness Related</p> <ul style="list-style-type: none"> • ECU pins Black 10, 12 and 16 damaged (wiring, connectors). • ECU pins Black 10, 12 and 16 routed near noisy electrical signal (coils, stator). • Intermittent 5 volt source from ECU (pin Black 16). • ECU-to-harness connection problem.

Fault Code	MIL Blinks	SPN	FMI
Code P0131	10/11/15/10	3056	4

Component:	Oxygen Sensor
Fault:	O2S 1 Circuit Low Voltage
Condition:	Open connection, broken wire or faulty sensor.
Conclusion:	<p>Oxygen Sensor Related</p> <ul style="list-style-type: none"> • Sensor connector or wiring problem. • Sensor contaminated, corroded or damaged. • Poor ground path. • Pin circuit wiring or connectors. <ul style="list-style-type: none"> ECU Black pin 10 or 17. <p>TPS Auto-Learn Incorrect</p> <ul style="list-style-type: none"> • Lean condition (check oxygen sensor signal with VOA and see Oxygen Sensor). <p>Engine wiring harness related such as a cut wire, broken or pinched.</p>

Fault Code	MIL Blinks	SPN	FMI
Code P0132	10/11/15/10	3056	3

Component:	Oxygen Sensor
Fault:	O2S 1 Circuit High Voltage
Condition:	Shorted connection or faulty sensor.
Conclusion:	<p>Oxygen Sensor Related</p> <ul style="list-style-type: none"> • Sensor connector or wiring problem. • Sensor contaminated or damaged. • Poor ground path. • Pin circuit wiring or connectors. <ul style="list-style-type: none"> ECU Black pin 10 or Black pin 17. <p>Engine Wiring Harness Related</p> <ul style="list-style-type: none"> • Difference in voltage between sensed voltage and actual sensor voltage. • Short in wire harness.

EFI SYSTEM-ELECTRONIC THROTTLE BODY (ETB) ECH

Fault Code	MIL Blinks	SPN	FMI
Code P0171	1/10/8/13	4237	0

Component:	Fuel System
Fault:	Maximum adaptation limit exceeded
Condition:	Fuel inlet screen/filter plugged, low pressure at high pressure fuel line, TPS malfunction, shorted connection, faulty O2 sensor, low fuel or wrong fuel type.
Conclusion:	<p>Oxygen Sensor Related</p> <ul style="list-style-type: none"> ● Corrosion or poor connection. ● Sensor contaminated or damaged. ● Air leak into exhaust. ● Poor ground path. ● Pin circuit wiring or connectors. ECU Black pin 10 or Black pin 17. <p>TPS Sensor Related</p> <ul style="list-style-type: none"> ● Throttle plate position incorrect during Auto-Learn. ● TPS problem or malfunction. <p>Engine Wiring Harness Related</p> <ul style="list-style-type: none"> ● Difference in voltage between sensed voltage and actual sensor voltage. ● Problem in wiring harness. ● ECU-to-harness connection problem. <p>Systems Related</p> <ul style="list-style-type: none"> ● Ignition (spark plug, plug wire, ignition coil). ● Fuel (fuel type/quality, injector, fuel pressure too low, fuel pump module or lift pump). ● Combustion air (air cleaner dirty/restricted, intake leak, throttle bore). ● Base engine problem (rings, valves). ● Exhaust system leak (muffler, flange, oxygen sensor mounting boss, etc.). ● Fuel in crankcase oil.

Fault Code	MIL Blinks	SPN	FMI
Code P0172	1/10/8/13	4237	1

Component:	Fuel System
Fault:	Minimum adaptation limit exceeded
Condition:	Too high pressure at high pressure fuel line, TPS malfunction, shorted connection, faulty O2 sensor or fuel pump module failure.
Conclusion:	<p>Oxygen Sensor Related</p> <ul style="list-style-type: none"> ● Sensor connector or wiring. ● Sensor contaminated or damaged. ● Poor ground path. ● Pin circuit wiring or connectors. ECU Black pin 10 or Black pin 17. <p>TPS Sensor Related</p> <ul style="list-style-type: none"> ● Throttle plate position incorrect during Auto-Learn. ● TPS problem or malfunction. <p>Engine Wiring Harness Related</p> <ul style="list-style-type: none"> ● Difference in voltage between sensed voltage and actual sensor voltage. ● Problem in wiring harness. ● ECU-to-harness connection problem. <p>Systems Related</p> <ul style="list-style-type: none"> ● Ignition (spark plug, plug wire, ignition coil). ● Fuel (fuel type/quality, injector, fuel pressure too high, fuel pump module or lift pump). ● Combustion air (air cleaner dirty/restricted). ● Base engine problem (rings, valves). ● Fuel in crankcase oil. ● Fuel pump module is over filled. ● Lift pump diaphragm is ruptured.

EFI SYSTEM-ELECTRONIC THROTTLE BODY (ETB) ECH

Fault Code	MIL Blinks	SPN	FMI
Code P0174	1/10/8/13	4237	31

Component:	Fuel System
Fault:	Lean fuel condition
Condition:	Fuel inlet screen/filter plugged, low pressure at high pressure fuel line, TPS malfunction, shorted connection or faulty sensor.
Conclusion:	<p>TPS Auto-Learn Incorrect</p> <ul style="list-style-type: none"> • Lean condition (check oxygen sensor signal with VOA and see Oxygen Sensor). <p>Engine Wiring Harness Related</p> <ul style="list-style-type: none"> • Pin circuit wiring or connectors. ECU pin Black 10, 12, 16 and 17. <p>Low Fuel Pressure</p> <ul style="list-style-type: none"> • Plugged filters. • Bad lift pump. • Vapor lock. <p>Oxygen Sensor Related</p> <ul style="list-style-type: none"> • Sensor connector or wiring problem. • Exhaust leak. • Poor ground. • Contaminated sensor. <p>Poor system ground from ECU to engine, causing rich running while indicating lean.</p> <p>Fuel pump module connection. See Fuel Components.</p>

Fault Code	MIL Blinks	SPN	FMI
Code P0201	10/2/8/11	651	31

Component:	Fuel Injector
Fault:	Injector 1 Circuit Malfunction
Condition:	Injector damaged or faulty, shorted or open connection.
Conclusion:	<p>Injector Related</p> <ul style="list-style-type: none"> • Injector coil shorted or opened. <p>Engine Wiring Harness Related</p> <ul style="list-style-type: none"> • Broken or shorted wire in harness. ECU pin Black 5. • Wiring from Ignition. <p>ECU Related</p> <ul style="list-style-type: none"> • Circuit controlling injector #1 damaged.

Fault Code	MIL Blinks	SPN	FMI
Code P0202	10/2/8/11	652	31

Component:	Fuel Injector
Fault:	Injector 2 Circuit Malfunction
Condition:	Injector damaged or faulty, shorted or open connection.
Conclusion:	<p>Injector Related</p> <ul style="list-style-type: none"> • Injector coil shorted or opened. <p>Engine Wiring Harness Related</p> <ul style="list-style-type: none"> • Broken or shorted wire in harness. ECU pin Black 6. • Wiring from Ignition. <p>ECU Related</p> <ul style="list-style-type: none"> • Circuit controlling injector #2 damaged.

Fault Code	MIL Blinks	SPN	FMI
Code P0217	10/10/6/14	110	0

Component:	Engine Overheat Warning
Fault:	Overheat
Condition:	Engine operating at or above recommended temperature limit.
Conclusion:	<p>Throttle opening is limited, value varies by engine model.</p> <ul style="list-style-type: none"> • Ramps in and out of limit. <p>Provides an alert to operator of a condition that may cause damage to engine.</p> <ul style="list-style-type: none"> • Typically this is remedied by clearing debris blocking engine cooling air flow.

EFI SYSTEM-ELECTRONIC THROTTLE BODY (ETB) ECH

Fault Code	MIL Blinks	SPN	FMI
Code P0230	10/5/4/3	1347	5

Component:	Fuel Pump
Fault:	Circuit Low Voltage or Open
Condition:	Shorted or open connection.
Conclusion:	<p>Fuel Pump Related</p> <ul style="list-style-type: none"> Fuel pump module open or shorted internally. <p>Engine Wiring Harness related</p> <ul style="list-style-type: none"> Broken or shorted wire in harness. ECU pin Black 9 or Grey 17. <p>ECU Related</p> <ul style="list-style-type: none"> ECU is damaged.

Fault Code	MIL Blinks	SPN	FMI
Code P0232	10/5/4/3	1347	6

Component:	Fuel Pump
Fault:	Circuit High Voltage
Condition:	Shorted connection.
Conclusion:	<p>Fuel Pump Related</p> <ul style="list-style-type: none"> Fuel pump module damaged internally. <p>Charging Output System Too High.</p>

Fault Code	MIL Blinks	SPN	FMI
Code P0336	10/2/7/12	636	2

Component:	Crankshaft Position Sensor
Fault:	Crankshaft Position Sensor Noisy Signal
Condition:	Loose sensor, faulty/bad battery, shorted or faulty connection, faulty sensor or faulty sensor grounding.
Conclusion:	<p>Crankshaft Position Sensor Related</p> <ul style="list-style-type: none"> Sensor connector or wiring. Sensor loose. <p>Crankshaft Position Sensor Wheel Related</p> <ul style="list-style-type: none"> Damaged teeth. Gap section not registering. <p>Engine Wiring Harness Related</p> <ul style="list-style-type: none"> Pin circuit wiring or connectors. ECU pin Black 4 and Black 13 may be routed near noisy signal (coils, stator, etc.). ECU-to-harness connection problem. <p>Ignition System Related</p> <ul style="list-style-type: none"> Non-resistor spark plug(s) used. Faulty or disconnected ignition coil or secondary lead.

Fault Code	MIL Blinks	SPN	FMI
Code P0337	10/2/7/12	636	8

NOTE: If fault code P0337 is present and engine does not start/run, proceed to step 1 of Crankshaft Position Sensor earlier in this section. If P0337 is present and engine operates, clear codes and retest.

Component:	Crankshaft Position Sensor
Fault:	Crankshaft Position Sensor No Signal
Condition:	Loose sensor, open or shorted connection (sensor connector or battery connections) or faulty sensor.
Conclusion:	<p>Crankshaft Position Sensor Related</p> <ul style="list-style-type: none"> A false fault code P0337 is triggered by a voltage drop with key ON and engine off. Voltage drop may be caused by a poor/inadequate battery connection, battery charger connected or disconnected, or any event that may interrupt voltage signal to ECU like a power interruption or heavy load from equipment that results in a recordable voltage drop. Sensor connector or wiring. Sensor loose. <p>Crankshaft Position Sensor Wheel Related</p> <ul style="list-style-type: none"> Damaged teeth. <p>Engine Wiring Harness Related</p> <ul style="list-style-type: none"> Pin circuit wiring or connectors. ECU pin Black 4 or Black 13. ECU-to-harness connection problem. <p>If code is stored in fault history and starts normally. Clear code, no other service required.</p>

EFI SYSTEM-ELECTRONIC THROTTLE BODY (ETB) ECH

Fault Code	MIL Blinks	SPN	FMI
Code P0351	10/4/15/4	1268	31

Component:	Ignition Coil
Fault:	Cylinder 1 Ignition Coil Malfunction
Condition:	Broken/shorted wire in harness (may not be visible), shorted connection or faulty sensor.
Conclusion:	Engine Wiring Harness Related <ul style="list-style-type: none"> ● Connection to ignition or fuse. ● Pin circuit wiring or connectors. ● ECU pin Black 1. ● ECU-to-harness connection problem. Ignition System Related <ul style="list-style-type: none"> ● Incorrect spark plug(s) used. ● Poor connection to spark plug.

Fault Code	MIL Blinks	SPN	FMI
Code P0352	10/4/15/4	1269	31

Component:	Ignition Coil
Fault:	Cylinder 2 Ignition Coil Malfunction
Condition:	Broken/shorted wire in harness (may not be visible), shorted connection or faulty sensor.
Conclusion:	Engine Wiring Harness Related <ul style="list-style-type: none"> ● Connection to ignition or fuse. ● Pin circuit wiring or connectors. ● ECU pin Grey 10. ● ECU-to-harness connection problem. Ignition System Related <ul style="list-style-type: none"> ● Incorrect spark plug(s) used. ● Poor connection to spark plug.

Fault Code	MIL Blinks	SPN	FMI
Code P0562	10/10/6/8	168	4

Component:	System Voltage
Fault:	System Voltage Low
Condition:	Faulty voltage regulator, bad fuse or shorted connection.
Conclusion:	Corroded Connections Bad Stator Bad Battery <ul style="list-style-type: none"> ● Low output charging system. ● Poor magnet in flywheel. ● Bad or missing fuse.

Fault Code	MIL Blinks	SPN	FMI
Code P0563	10/10/6/8	168	3

Component:	System Voltage
Fault:	System Voltage High
Condition:	Faulty voltage regulator or shorted connection.
Conclusion:	Faulty Rectifier-Regulator Bad Stator. Bad Battery.

Fault Code	MIL Blinks	SPN	FMI
Code P2100	1/5/2/11	5419	5

Component:	Throttle Actuator Control Motor Circuit Open
Fault:	Low Current
Condition:	Throttle drive motor open circuit.
Conclusion:	Engine will only run at fixed low speed.

Fault Code	MIL Blinks	SPN	FMI
Code P2119	1/5/2/11	5419	7

Component:	Throttle Actuator
Fault:	Sticking/sticky/binding
Condition:	Throttle performance-binding
Conclusion:	Movement of throttle blade is restricted.

Code 61

Component:	End of Code Transmission
------------	--------------------------

EFI SYSTEM-ELECTRONIC THROTTLE BODY (ETB) ECH

EFI Diagnostic Flow Diagram

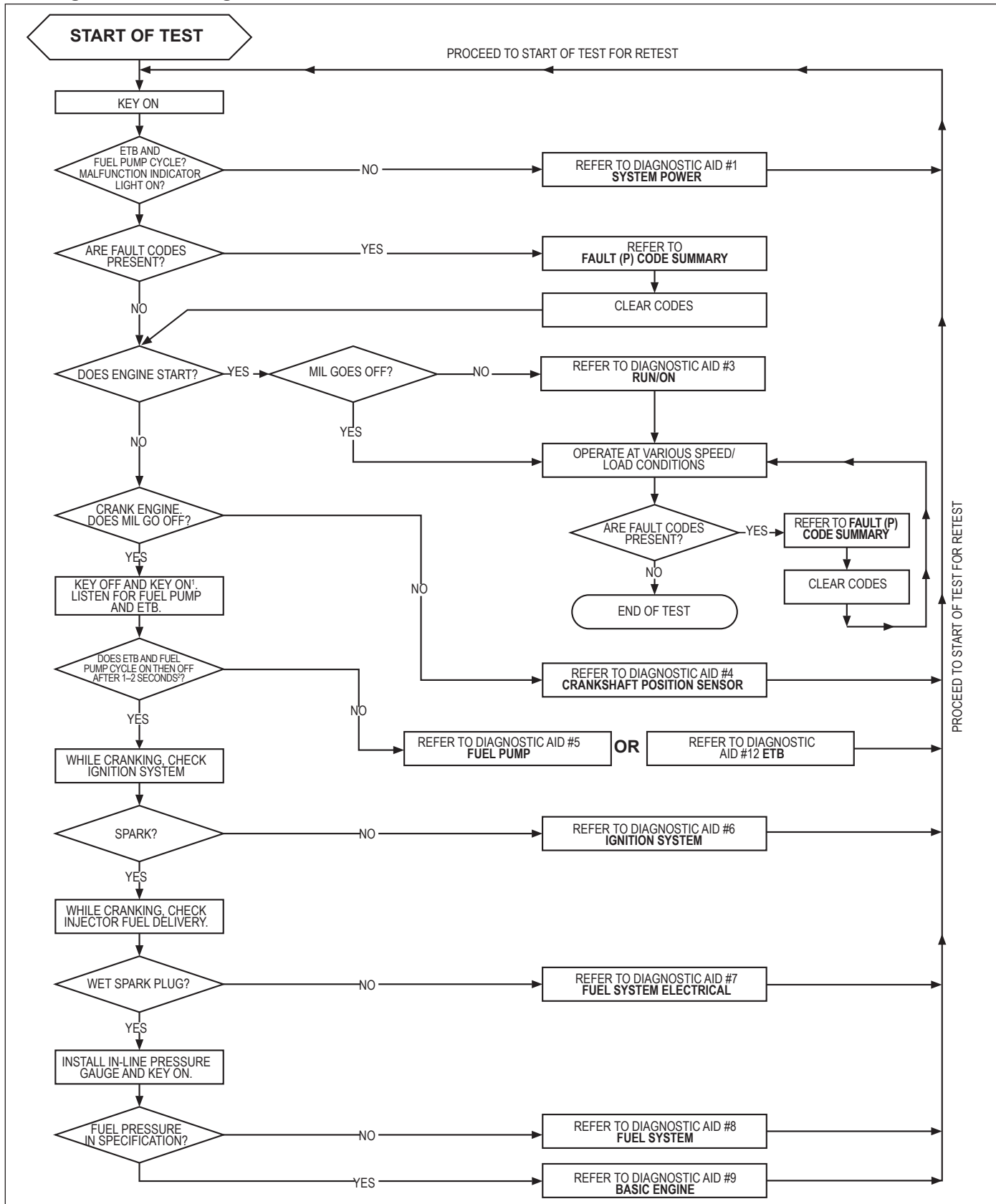

1. After turning key to OFF, wait 10 seconds before turning to ON to allow ECU to go to sleep.
2. Fuel pump module can be heard or a vibration can be felt to establish pump cycle. Fuel pump module will run for one 4-6 second cycle when ECU wakes up after being asleep.

EFI SYSTEM-ELECTRONIC THROTTLE BODY (ETB) ECH

Troubleshooting Flow Chart

Following flow chart provides an alternative method of troubleshooting EFI system. Chart will enable you to review entire system in about 10-15 minutes. Using chart, accompanying diagnostic aids (listed after chart), and any signaled fault codes, you should be able to quickly locate any problems within system.

Flow Chart Diagnostic Aids

Diagnostic Aid #1 SYSTEM POWER

(MIL does not illuminate when key is turned ON)

NOTE: MIL is installed by vehicle OEM. Twelve volt supply to bulb will be part of vehicle wire harness. Rehlko key switch model will have MIL on engine with 12V supply to bulb.

Conclusion

- Battery
- Main system fuse
- MIL light bulb burned out
- MIL electrical circuit problem
 - Pin circuits Grey 3.
- Ignition switch
- Permanent ECU power circuit problem
 - Pin circuit Black 18.
- Switched ECU power circuit problem
 - Pin circuit Black 15.
- ECU grounds
- ECU

Diagnostic Aid #2 FAULT CODES

Refer to Diagnostic Fault Code Summary.

Diagnostic Aid #3 RUN/ON

(MIL remains ON while engine is running)*

Condition

NOTE: Either incandescent or LED type bulbs can be used for MIL as long as they do not draw more than 0.1 amps. Bulb needs to be rated at 1.4 Watts or less, or needs to have a total resistance of 140 Ω or more. LEDs typically draw less than 0.03 amps.

*All current fault codes will turn on MIL when engine is running.

Diagnostic Aid #4 CRANKSHAFT POSITION SENSOR

(MIL does not turn off during cranking)

Condition

- Crankshaft position sensor
- Crankshaft position sensor circuit problem, pin circuits Black 4 and Black 13.
- Crankshaft position sensor/toothed wheel air gap
- Toothed wheel
- Flywheel key sheared
- ECU

Diagnostic Aid #5 FUEL PUMP

(fuel pump not turning on)

Condition

- Main fuse
- Fuel pump circuit problem, pin circuits Black 9 and Grey 17.
- Fuel pump module

Diagnostic Aid #6 IGNITION SYSTEM

(no spark)

Condition

- Spark plug
- Plug wire
- Coil
- Coil circuit(s), pin circuits Grey 10 and Black 1.
- ECU grounds
- ECU
- Vehicle safety interlocks, ground signal on safety wire.

Diagnostic Aid #7 FUEL SYSTEM ELECTRICAL

(no fuel delivery)

Condition

- No fuel
- Air in high pressure fuel line
- Fuel valve shut OFF
- Fuel filter/line plugged
- Injector circuit(s), pin circuits Black 5 and Black 6
- Injector
- ECU grounds
- ECU
- Lift pump not working

Diagnostic Aid #8 FUEL SYSTEM

(fuel pressure)

Low Fuel Pressure-Condition

- Low fuel
- Fuel filter plugged
- Fuel supply line plugged
- Lift fuel pump - insufficient fuel supply
- Fuel pump (lift or module) - internally plugged
- Pressure regulator not functioning properly inside fuel pump module.

Diagnostic Aid #9 BASIC ENGINE

(cranks but will not run)

Condition

- Refer to basic engine troubleshooting charts within Troubleshooting.

Diagnostic Aid #10 SPEED CONTROL-Analog (0-5V input)

(engine speed does not change when requested)

Condition

- Speed request voltage from OEM controller is not being received by engine. Consult OEM service information for OEM diagnostics.
- Bad connection in speed input circuit (terminal G in engine connector, red w/yellow tracer).
- Bad connection in engine connectors (ETB/equipment connector).
- Stuck/damaged ETB assembly.

EFI SYSTEM-ELECTRONIC THROTTLE BODY (ETB) ECH

Diagnostic Aid #11 SPEED CONTROL-CAN

Communications

(engine speed does not change when requested)

Condition

- Speed request from OEM CAN controller is not being received by engine. Consult OEM service information for OEM diagnostics.
- Bad connection in engine connectors (ETB/equipment connector).
- Stuck/damaged ETB assembly.

Diagnostic Aid #12 ETB

(ETB does not cycle when key is switched from off to on)

Condition

- Blown power fuse
- Bad electrical connection
- Stuck throttle plate
- Defective throttle

EFI SYSTEM-ECH WITH OXYGEN SENSOR

	⚠ WARNING
	Explosive Fuel can cause fires and severe burns. Do not fill fuel tank while engine is hot or running.
Gasoline is extremely flammable and its vapors can explode if ignited. Store gasoline only in approved containers, in well ventilated, unoccupied buildings, away from sparks or flames. Spilled fuel could ignite if it comes in contact with hot parts or sparks from ignition. Never use gasoline as a cleaning agent.	

Typical electronic fuel injection (EFI) system and related components include:

- Fuel pump module and lift pump.
- Fuel filter.
- High pressure fuel line.
- Fuel line(s).
- Fuel injectors.
- Throttle body/intake manifold.
- Electronic control unit (ECU).
- Ignition coils.
- Engine temperature sensor.
- Throttle position sensor (TPS). Earlier engines have a contacting (brushes) TPS. Later engines have a contactless (magnetic) TPS.
- Crankshaft position sensor.
- Oxygen sensor.
- Earlier engines have a separate manifold absolute pressure sensor (MAP) and an intake air temperature (IAT) sensor (located in throttle body).
- Later engines have a combined temperature/manifold absolute pressure (TMAP) sensor.
- Malfunction indicator light (MIL) - optional.
- Wire harness assembly & affiliated wiring.

FUEL RECOMMENDATIONS

Refer to Maintenance.

FUEL LINE

Low permeation fuel line must be installed on all Rehlko engines to maintain EPA and CARB regulatory compliance.

OPERATION

NOTE: When performing voltage or continuity tests, avoid putting excessive pressure on or against connector pins. Flat pin probes are recommended for testing to avoid spreading or bending terminals.

EFI system is designed to provide peak engine performance with optimum fuel efficiency and lowest possible emissions. Ignition and injection functions are electronically controlled, monitored and continually corrected during operation to maintain ideal air/fuel ratio.

Central component of system is Electronic Control Unit (ECU) which manages system operation, determining best combination of fuel mixture and ignition timing for current operating conditions.

A lift fuel pump is used to move fuel from tank through an in-line fuel filter and fuel line. Fuel is then pumped to fuel pump module. Fuel pump module regulates fuel pressure to a system operating pressure of 39 psi. Fuel is delivered from fuel pump module through high pressure fuel line into injectors, which inject fuel into intake ports. ECU controls amount of fuel by varying length of time that injectors are on. This can range from 2 to over 12 milliseconds depending on fuel requirements. Controlled injection of fuel occurs every other crankshaft revolution, or once for each 4-stroke cycle. When intake valve opens, air/fuel mixture is drawn into combustion chamber, compressed, ignited, and burned.

ECU controls amount of fuel being injected and ignition timing by monitoring primary sensor signals for engine temperature, speed (RPM), and throttle position (load). These primary signals are compared to preprogrammed maps in ECU computer chip, and ECU adjusts fuel delivery to match mapped values. After engine reaches operating temperature, an exhaust gas oxygen sensor provides feedback to ECU based upon amount of unused oxygen in exhaust, indicating whether fuel mixture being delivered is rich or lean. Based upon this feedback, ECU further adjusts fuel input to re-establish ideal air/fuel ratio. This operating mode is referred to as closed loop operation. EFI system operates closed loop when all three of following conditions are met:

- Engine temperature is greater than 50-60°C (122-140°F).
- Oxygen sensor has warmed sufficiently to provide a signal (minimum 400°C, 752°F).
- Engine operation is at a steady state (not starting, warming up, accelerating, etc.).

During closed loop operation ECU has ability to readjust and learn adaptive controls, providing compensation for changes in overall engine condition and operating environment, so it will be able to maintain ideal air/fuel ratio. This system requires a minimum engine oil temperature greater than 60-70°C (140-158°F) to properly adapt. These adaptive values are maintained as long as ECU is not reset.

During certain operating periods such as cold starts, warm up, acceleration, high load, etc., a richer air/fuel ratio is required and system operates in an open loop mode. In open loop operation oxygen sensor output is used to ensure engine is running rich, and controlling adjustments are based on primary sensor signals and programmed maps only. This system operates open loop whenever three conditions for closed loop operation (above) are not being met.

ECU is brain or central processing computer of entire EFI system. During operation, sensors continuously gather data which is relayed through wiring harness to input circuits within ECU. Signals to ECU include: ignition (on/off), crankshaft position and speed (RPM), throttle position, oil temperature, intake air temperature, exhaust oxygen levels, manifold absolute pressure, and battery voltage.

EFI SYSTEM-ECH WITH OXYGEN SENSOR

ECU compares input signals to programmed maps in its memory to determine appropriate fuel and spark requirements for immediate operating conditions. ECU then sends output signals to set injector duration and ignition timing.

ECU continually performs a diagnostic check of itself, each of sensors, and system performance. If a fault is detected, ECU can turn on a Malfunction Indicator Light (MIL) (if equipped) on equipment control panel, store fault code in its fault memory, and go into a default operating mode. Depending on significance or severity of fault, normal operation may continue. A technician can access stored fault code using a blink code diagnosis flashed out through MIL. An optional computer software diagnostic program is also available, see Tools and Aids.

ECU requires a minimum of 6.0 volts to operate.

To prevent engine over-speed and possible failure, a rev-limiting feature is programmed into ECU. If maximum RPM limit (4500) is exceeded, ECU suppresses injection signals, cutting off fuel flow. This process repeats itself in rapid succession, limiting operation to preset maximum.

Wiring harness used in EFI system connects electrical components, providing current and ground paths for system to operate. All input and output signaling occurs through two special all weather connectors that attach and lock to ECU. Connectors are Black and Grey and keyed differently to prevent being attached to ECU incorrectly.

Condition of wiring, connectors, and terminal connections is essential to system function and performance. Corrosion, moisture, and poor connections are as likely cause of operating problems and system errors as an actual component. Refer to Electrical System for additional information.

EFI system is a 12 VDC negative ground system, designed to operate down to a minimum of 6.0 volts. If system voltage drops below this level, operation of voltage sensitive components such as ECU, fuel pump, ignition coils, and injectors will be intermittent or disrupted, causing erratic operation or hard starting. A fully charged, 12 volt battery with a minimum of 350 cold cranking amps is important in maintaining steady and reliable system operation. Battery condition and state of charge should always be checked first when troubleshooting an operational problem.

Keep in mind that EFI-related problems are often caused by wiring harness or connections. Even small amounts of corrosion or oxidation on terminals can interfere with milliamp currents used in system operation.

Cleaning connectors and grounds will solve problems in many cases. In an emergency situation, simply disconnecting and reconnecting connectors may clean up contacts enough to restore operation, at least temporarily.

If a fault code indicates a problem with an electrical component, disconnect ECU connector and test for continuity between component connector terminals and corresponding terminals in ECU connector using an ohmmeter. Little or no resistance should be measured, indicating that wiring of that particular circuit is OK.

Crankshaft Position Sensor Bracket

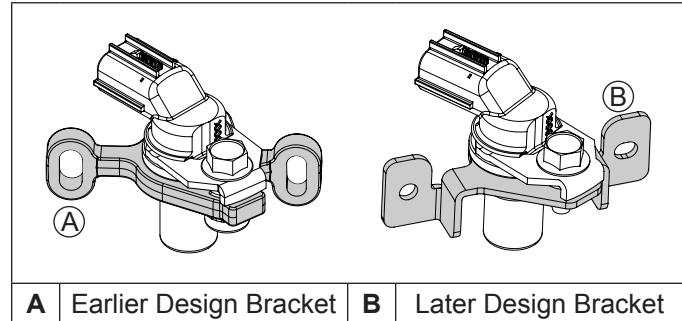

Crankshaft position sensor is essential to engine operation; constantly monitoring rotation and speed (RPM) of crankshaft. There are 23 consecutive teeth cast into flywheel. One tooth is missing and is used to reference crankshaft position for ECU. Inductive crankshaft position sensor with earlier design bracket is mounted 0.20-0.70 mm (0.008-0.027 in.) from flywheel. Later design bracket requires no adjustment.

During rotation, an AC voltage pulse is created within sensor for each passing tooth. ECU calculates engine speed from time interval between consecutive pulses. Gap from missing tooth creates an interrupted input signal, corresponding to specific crankshaft position near BDC for cylinder #1. This signal serves as a reference for control of ignition timing by ECU. Synchronization of inductive speed pickup and crankshaft position takes place during first two revolutions each time engine is started. Sensor must be properly connected at all times. If sensor becomes disconnected for any reason, engine will quit running.

Throttle position sensor (TPS) is used to indicate throttle plate angle to ECU. Since throttle (by way of governor) reacts to engine load, angle of throttle plate is directly related to load on engine.

Mounted on throttle body and operated directly off end of throttle shaft, TPS works as a potentiometer, varying voltage signal to ECU in direct correlation to angle of throttle plate. This signal, along with other sensor signals, is processed by ECU and compared to internal preprogrammed maps to determine required fuel and ignition settings for amount of load.

Correct position of TPS is established and set at factory. Do not loosen TPS or alter mounting position unless absolutely required by fault code diagnosis. If TPS is loosened or repositioned, appropriate TPS Learn Procedure must be performed to re-establish baseline relationship between ECU and TPS.

Engine temperature sensor is used by system to help determine fuel requirements for starting (a cold engine needs more fuel than one at or near operating temperature).

Mounted in breather cover, it has a temperature-sensitive resistor that extends into oil flow. Resistance changes with oil temperature, altering voltage sent to ECU. Using a table stored in its memory, ECU correlates voltage drop to a specific temperature. Using fuel delivery maps, ECU then knows how much fuel is required for starting at that temperature.

EFI SYSTEM-ECH WITH OXYGEN SENSOR

Earlier engines have a separate intake air temperature (IAT) sensor (located in throttle body) and a manifold absolute pressure (MAP) sensor. Later engines have a combined temperature/manifold absolute pressure (TMAP) sensor.

Intake Air Temperature (IAT) sensor is a thermally sensitive resistor that exhibits a change in electrical resistance with a change in its temperature. When sensor is cold, resistance of sensor is high. As sensor warms up, resistance drops and voltage signal increases. From voltage signal, ECU can determine temperature of intake air.

Purpose of an air temperature sensor is to help ECU calculate air density. Higher air temperature less dense air becomes. As air becomes less dense ECU knows that it needs to lessen fuel flow to achieve correct air/fuel ratio. If fuel ratio was not changed engine would become rich, possibly losing power and consuming more fuel.

Manifold absolute pressure (MAP) sensor provides immediate manifold pressure information to ECU. MAP measures difference in pressure between outside atmosphere and vacuum level inside intake manifold and monitors pressure in manifold as primary means of detecting load. Data is used to calculate air density and determine engine's mass air flow rate, which in turn determines required ideal fueling. MAP also stores instant barometric pressure reading when key is turned ON.

Later engines have a Temperature/Manifold Absolute Pressure (TMAP) sensor. This is an integrated sensor that checks both intake air temperature and manifold absolute pressure. This combined sensor is located in intake manifold.

Oxygen sensor functions like a small battery, generating a voltage signal to ECU based upon difference in oxygen content between exhaust gas and ambient air.

Tip of sensor, protruding into exhaust gas, is hollow. Outer portion of tip is surrounded by exhaust gas, with inner portion exposed to ambient air. When oxygen concentration on one side of tip is different than that of other side, a voltage signal up to 1.0 volt is generated and sent to ECU. Voltage signal tells ECU if engine is straying from ideal fuel mixture, and ECU then adjusts injector pulse accordingly.

Oxygen sensor functions after being heated to a minimum of 400°C (752°F). A heater inside sensor heats electrode to optimum temperature in about 10 seconds. Oxygen sensor receives ground through wire, eliminating need for proper grounding through muffler. If problems indicate a bad oxygen sensor, check all connections and wire harness. Oxygen sensor can also be contaminated by leaded fuel, certain RTV and/or other silicone compounds, fuel injector cleaners, etc. Use only those products indicated as O2 Sensor Safe.

Fuel injectors mount into intake manifold, and high pressure fuel line attaches to them at top end. Replaceable O-rings on both ends of injector prevent external fuel leakage and also insulate it from heat and vibration. A special clip connects each injector to high pressure fuel line and holds it in place. O-rings and retaining clip must be replaced any time fuel injector is separated from its normal mounting position.

When key switch is on, fuel pump module will pressurize high pressure fuel line to 39 psi, and voltage is present at injector. At proper instant, ECU completes ground circuit, energizing injector. Valve needle in injector is opened electromagnetically, and pressure in high pressure fuel line forces fuel down through inside. Director plate at tip of injector contains a series of calibrated openings which directs fuel into manifold in a cone-shaped spray pattern.

Injectors have sequential fueling that open and close once every other crankshaft revolution. Amount of fuel injected is controlled by ECU and determined by length of time valve needle is held open, also referred to as injection duration or pulse width. Time injector is open (milliseconds) may vary in duration depending on speed and load requirements of engine.

A high-voltage, solid-state, battery ignition system is used with EFI system. ECU controls ignition output and timing through transistorized control of primary current delivered to coils. Based on input from crankshaft position sensor, ECU determines correct firing point for speed at which engine is running. At proper instant, it interrupts flow of primary current in coil, causing electromagnetic flux field to collapse. Flux collapse induces an instantaneous high voltage in coil secondary which is strong enough to bridge gap on spark plug. Each coil fires every other revolution.

EFI engines are equipped with either a 20 or 25 amp charging system to accommodate combined electrical demands of ignition system and specific application. Charging system troubleshooting information is provided in Electrical System.

An electric fuel pump module and a lift pump (two types) are used to transfer fuel in EFI system. Types of lift pumps are: a pulse fuel pump, a mechanical fuel pump, or a low pressure electric fuel pump. Pumping action is created by either oscillation of positive and negative pressures within crankcase through a hose, or by direct lever/pump actuation off rocker arm movement. Pumping action causes diaphragm on inside of pump to pull fuel in on its downward stroke and to push it into fuel pump module on its upward stroke. Internal check valves prevent fuel from going backward through pump. Fuel pump module receives fuel from lift pump, increases and regulates pressure for fuel injectors.

EFI SYSTEM-ECH WITH OXYGEN SENSOR

Fuel pump module is rated for a minimum output of 13.5 liters per hour and regulated at 270 kilopascals (39 psi).

When key switch is turned ON and all safety switch requirements are met, ECU activates fuel pump module for about six seconds, which pressurizes system for start-up. If key switch is not promptly turned to start position, engine fails to start, or engine is stopped with key switch ON (as in case of an accident), ECU switches off pump preventing continued delivery of fuel. In this situation, MIL will go on, but it will go back off after 4 cranking revolutions if system function is OK. Once engine is running, fuel pump remains on.

Precision components inside fuel pump module are not serviceable. DO NOT attempt to open fuel pump module. Damage to components will result and warranty will be void. Because fuel pump module is not serviceable, engines are equipped with a special 10-micron EFI fuel filter to prevent harmful contamination from entering module.

If there are two filters in system, one before lift pump will be a standard 51-75 micron filter, and one after lift pump will be special 10-micron filter. Be sure to use an approved 10-micron filter for replacement.

High pressure fuel line is an assembly of hoses, injector caps and a fuel connector to fuel pump module. High pressure fuel line feeds fuel to top of injectors through injector caps. Caps are fastened to intake manifold and injectors are locked into place. A small retaining clip provides a secondary lock.

High pressure fuel line is serviced as a complete assembly to prevent tampering and safety hazards. Components are not individually serviceable.

Vent hose assembly is intended to vent fuel vapor out of fuel pump module and direct fuel vapor into throttle body. Most EFI engines are equipped with an engine mounted purge port on #2 cylinder barrel baffle. This capped purge port can be used by OEM to vent fuel tanks or used in conjunction with a carbon canister kit for Tier III evaporative emissions compliance. Purge port connects to vent hose assembly and directs all fuel vapor into throttle body. If purge port remains unused, port must remain capped to prevent dirt from entering engine.

EFI engines have no carburetor, so throttle function (regulate incoming combustion airflow) is achieved with a throttle valve in a separate throttle body attached to intake manifold. Throttle body/intake manifold provides mounting for fuel injectors, throttle position sensor, either a separate MAP sensor and an intake air temperature (IAT) sensor, or a TMAP sensor, high pressure fuel line, idle speed screw, and air cleaner assembly.

Idle speed is only adjustment that may be performed on EFI system. Standard idle speed setting for EFI engines is 1500 RPM, but certain applications might require a different setting. Check equipment manufacturer's recommendation.

For starting and warm up, ECU will adjust fuel and ignition timing, based upon ambient temperature, engine temperature, and loads present. In cold conditions, idle speed will probably be different than normal for a few moments. Under other conditions, idle speed may actually start lower than normal, but gradually increase to established setting as operation continues. Do not attempt to circumvent this warm up period, or readjust idle speed during this time. Engine must be completely warmed up, in closed loop operating mode for accurate idle adjustment.

IMPORTANT NOTES!

- Cleanliness is essential and must be maintained at all times when servicing or working on EFI system. Dirt, even in small quantities, can cause significant problems.
- Clean any joint or fitting with parts cleaning solvent before opening to prevent dirt from entering system.
- Always depressurize fuel system through fuel connector on fuel pump module before disconnecting or servicing any fuel system components.
- Never attempt to service any fuel system component while engine is running or ignition switch is ON.
- Do not use compressed air if system is open. Cover any parts removed and wrap any open joints with plastic if they will remain open for any length of time. New parts should be removed from their protective packaging just prior to installation.
- Avoid direct water or spray contact with system components.
- Do not disconnect or reconnect ECU wiring harness connector or any individual components with ignition on. This can send a damaging voltage spike through ECU.
- Do not allow battery cables to touch opposing terminals. When connecting battery cables attach positive (+) cable to positive (+) battery terminal first, followed by negative (-) cable to negative (-) battery terminal.
- Never start engine when cables are loose or poorly connected to battery terminals.
- Never disconnect battery while engine is running.
- Never use a quick battery charger to start engine.
- Do not charge battery with key switch ON.
- Always disconnect negative (-) battery cable before charging battery, and also unplug harness from ECU before performing any welding on equipment.

EFI SYSTEM-ECH WITH OXYGEN SENSOR

ELECTRICAL COMPONENTS

Electronic Control Unit (ECU)

Pinout of ECU

Black Connector Side	
Pin #	Function
1	Ignition Coil #1 Ground
2	Battery Ground
3	Diagnostic Communication Line
4	Speed Sensor input
5	Fuel Injector Output #1 Ground
6	Fuel Injector Output #2 Ground
7	Oxygen Sensor Heater
8	Intake Air Temperature (IAT) sensor or TMAP sensor input
9	Fuel Pump Ground
10	Ground for TPS, IAT and MAP sensors or TMAP sensor, O2 and Engine Temperature sensors
11	MAP sensor or TMAP sensor input
12	Throttle Position Sensor (TPS) input
13	Speed Sensor Ground
14	Engine Temperature Sensor input
15	Ignition Switch (Switched +12V)
16	Power for TPS sensor, MAP sensor or TMAP sensor (+5V)
17	Oxygen Sensor (O2) input
18	Battery Power (Permanent +12V)

Grey Connector Side	
Pin #	Description
1	Not Used
2	Not Used
3	Malfunction Indicator Light (MIL) Ground
4	Not Used
5	Not Used
6	Not Used
7	Not Used
8	Not Used
9	Battery Ground
10	Ignition Coil #2 Ground
11	Not Used
12	Not Used
13	Not Used
14	Safety Switch Ground
15	Not Used
16	ECU
17	Fuel Pump Control (+12V)
18	Not Used

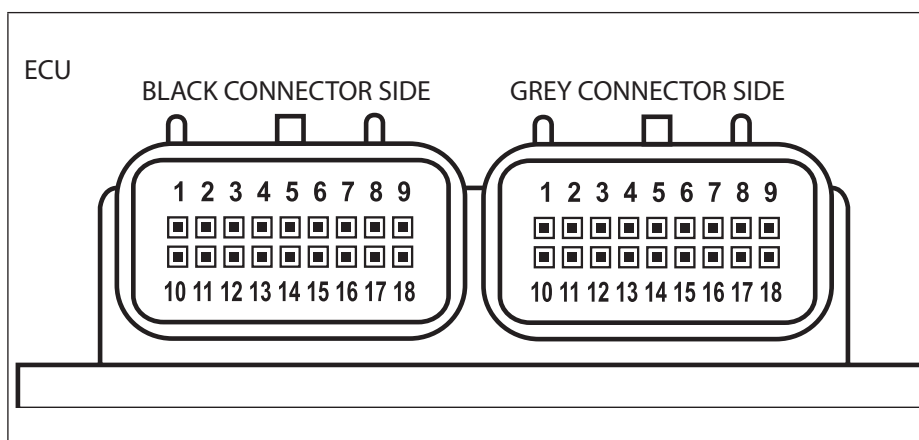

Pinout of ECU

EFI SYSTEM-ECH WITH OXYGEN SENSOR

Never attempt to disassemble ECU. It is sealed to prevent damage to internal components. Warranty is void if case is opened or tampered with in any way.

All operating and control functions within ECU are preset. No internal servicing or readjustment may be performed. If a problem is encountered, and you determine ECU to be faulty, contact your source of supply.

ECU pins are coated at factory with a thin layer of electrical grease to prevent fretting and corrosion. Do not attempt to remove grease from ECU pins.

Relationship between ECU and throttle position sensor (TPS) is very critical to proper system operation. If TPS or ECU is changed, or mounting position of TPS is altered, appropriate TPS Learn Procedure must be performed to restore synchronization.

Any service to ECU, TPS/Throttle Body (including idle speed increase over 300 RPM), or fuel pump module replacement should include ECU Reset.

This will clear all trouble codes, all closed loop learned offsets, all max values, and all timers besides permanent hour meter.

This system will NOT reset when battery is disconnected!

ECU Reset Procedure

1. Turn key/ignition OFF.
2. Install Red wire jumper from Rehlko EFI service kit on to service port (connect white wire to black wire in 4 way diagnostic port).
3. Turn key/ignition ON, then OFF and count 10 seconds.
4. Turn key/ignition ON, then OFF and count to 10 seconds a second time.
5. Remove Red wire jumper. Turn key/ignition ON, then OFF and count to 10 seconds a third time. ECU is reset.

A TPS Learn Procedure **must** be performed after ECU Reset.

TPS Learn Procedure

1. Turn idle screw clockwise one full turn prior to key/ignition ON after ECU Reset.
2. Start engine, run at low idle until engine is warm.
3. Idle speed must be above 1500 RPM. If below 1500 RPM, turn idle screw up to 1700 RPM and then shut down engine and perform ECU Reset again.
4. Adjust idle speed down to 1500 RPM. Allow engine to dwell at 1500 RPM for about 3 seconds.
5. After this, adjust idle speed to final specified speed setting.
6. Turn key/ignition OFF and count to 10 seconds.

Learn procedure is complete.

EFI SYSTEM-ECH WITH OXYGEN SENSOR

Wiring Harness

EFI Wiring Diagram 6-Terminal Connector (engines with separate MAP sensor and intake air temperature sensor)

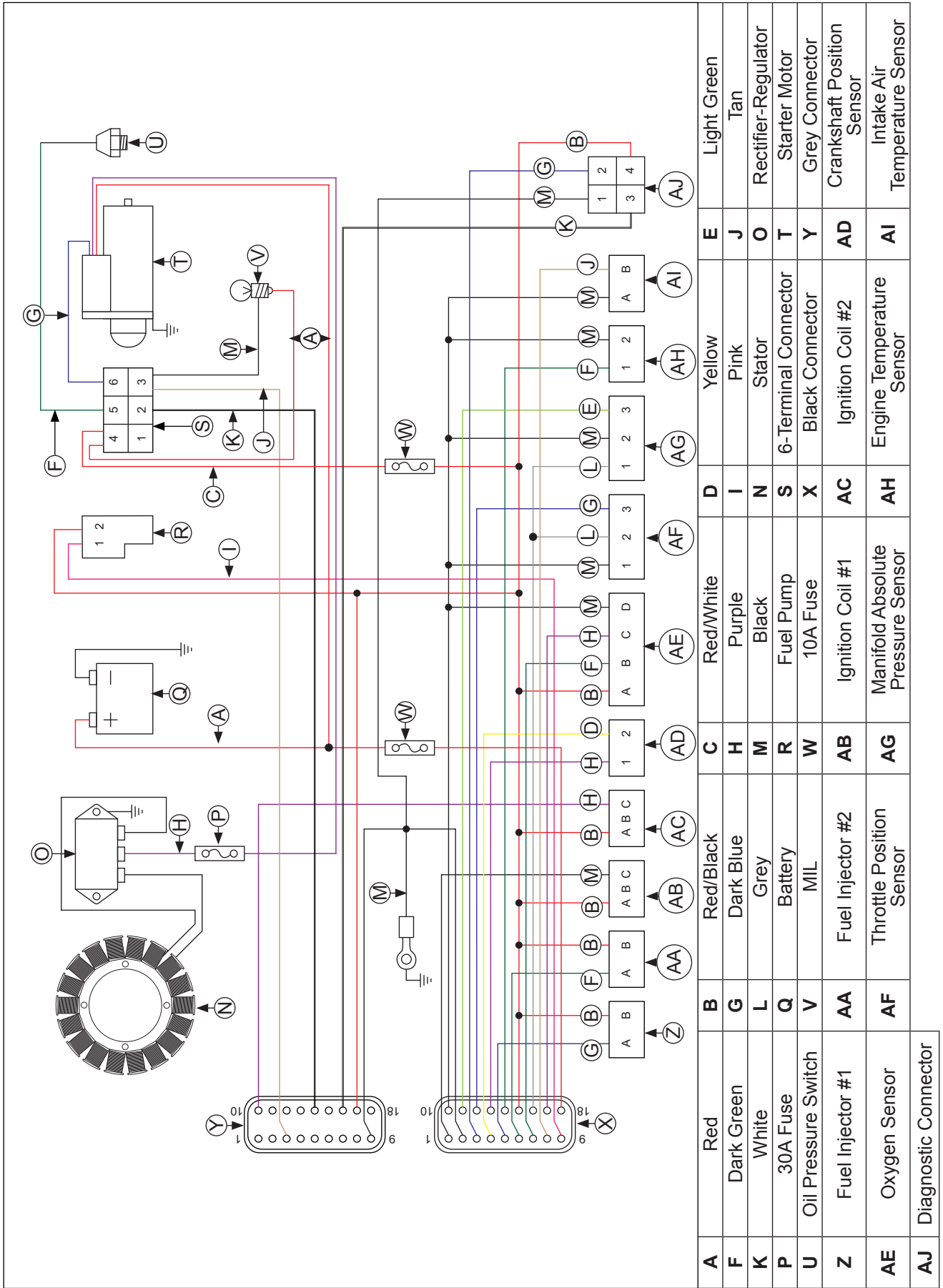

EFI SYSTEM-ECH WITH OXYGEN SENSOR

EFI Wiring Diagram 5-Terminal Connector and Optional Key Switch (engines with separate MAP sensor and intake air temperature sensor)

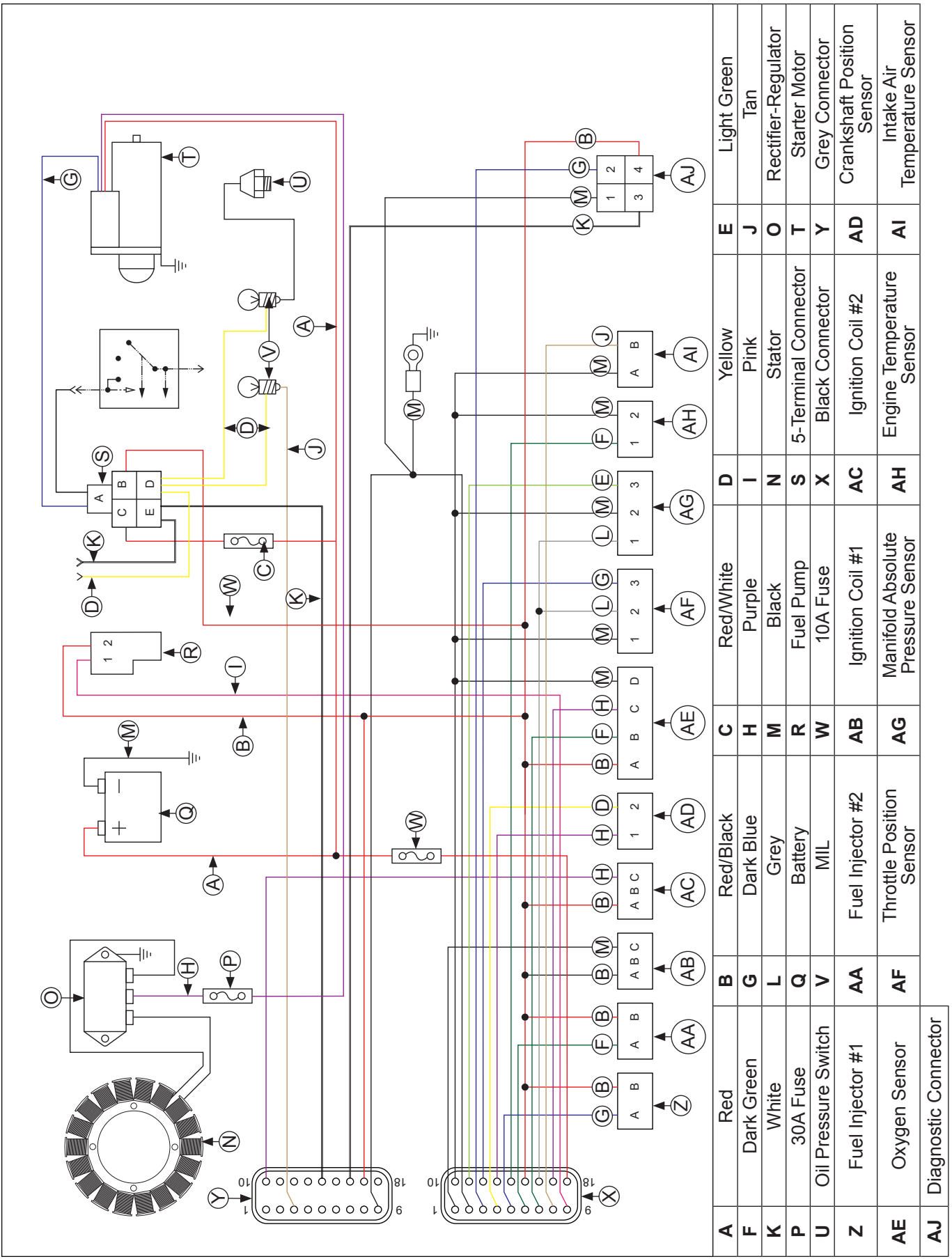

EFI SYSTEM-ECH WITH OXYGEN SENSOR

EFI Wiring Diagram 6-Terminal Connector (engines with TMAP sensor)

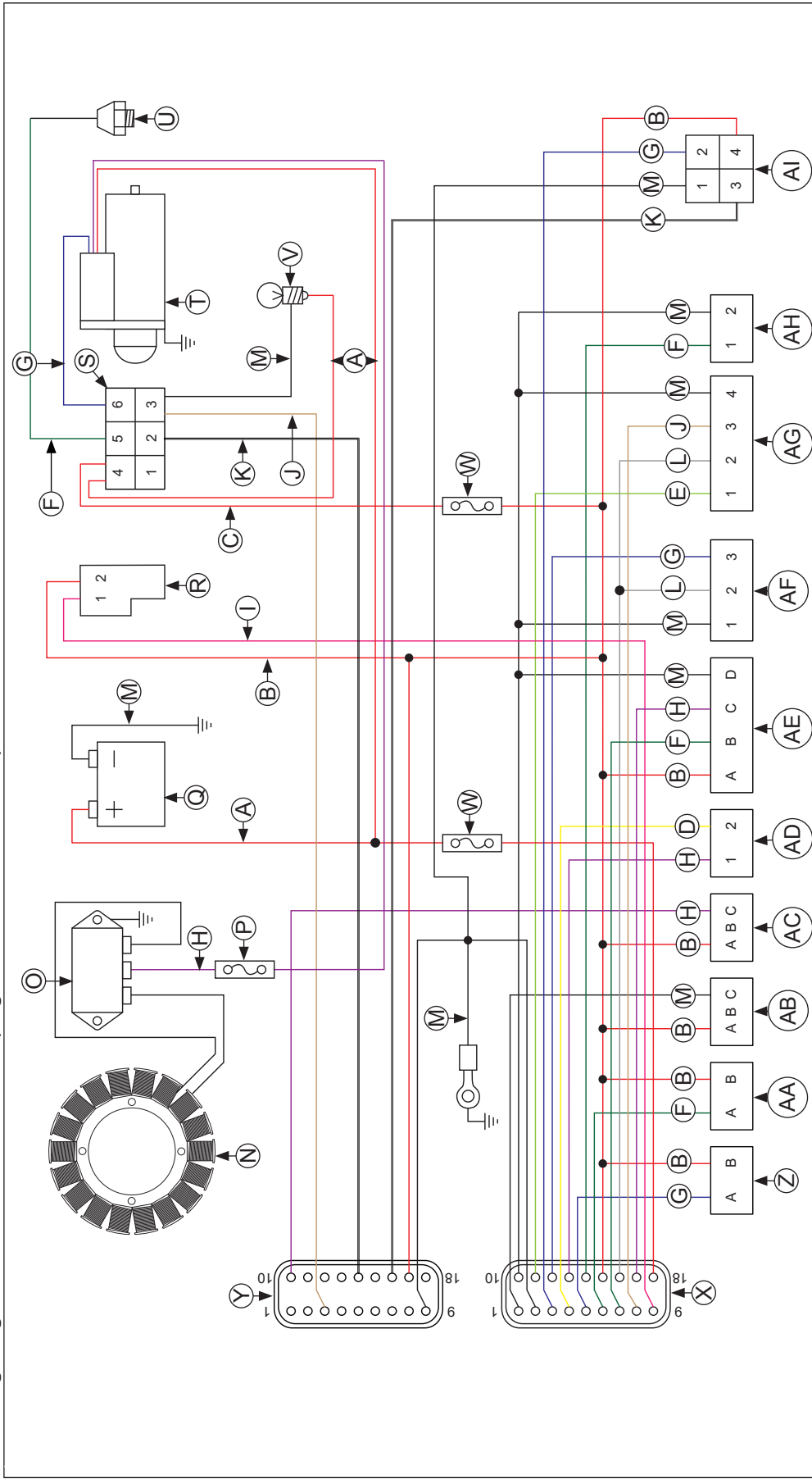

A	Red	B	Red/Black	C	Red/White	D	Yellow	E	Light Green
F	Dark Green	G	Dark Blue	H	Purple	I	Pink	J	Tan
K	White	L	Grey	M	Black	N	Stator	O	Rectifier-Regulator
P	30A Fuse	Q	Battery	R	Fuel Pump	S	6-Terminal Connector	T	Starter Motor
U	Oil Pressure Switch	V	MIL (Optional)	W	10A Fuse	X	Black Connector	Y	Grey Connector
Z	Fuel Injector #1	AA	Fuel Injector #2	AB	Ignition Coil #1	AC	Ignition Coil #2	AD	Crankshaft Position Sensor
AE	Oxygen Sensor	AF	Throttle Position Sensor	AG	TMAP Sensor	AH	Engine Temperature Sensor	AI	Diagnostic Connector

EFI SYSTEM-ECH WITH OXYGEN SENSOR

EFI Wiring Diagram 5-Terminal Connector and Optional Key Switch (engines with TMAP sensor)

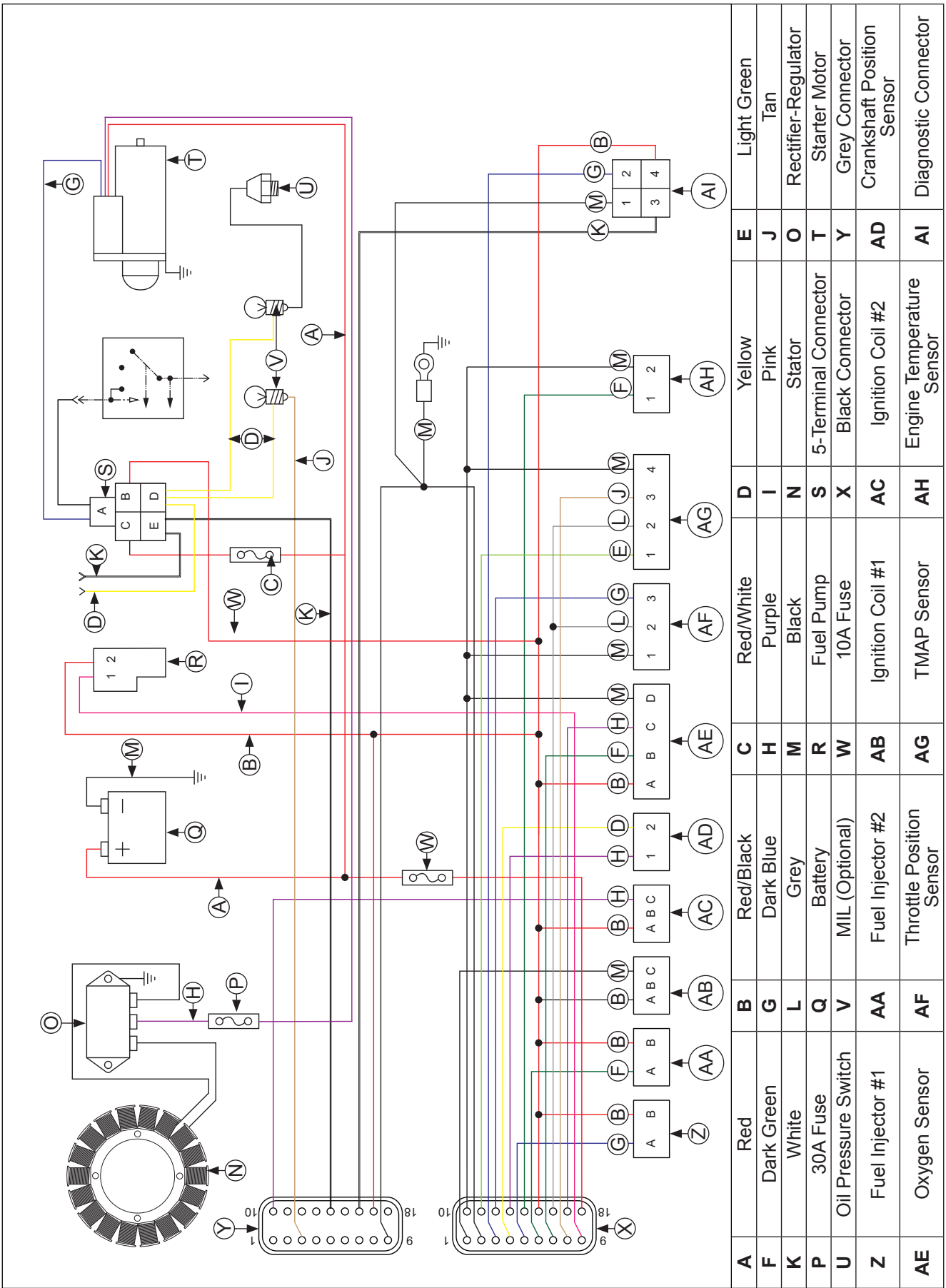

Crankshaft Position Sensor

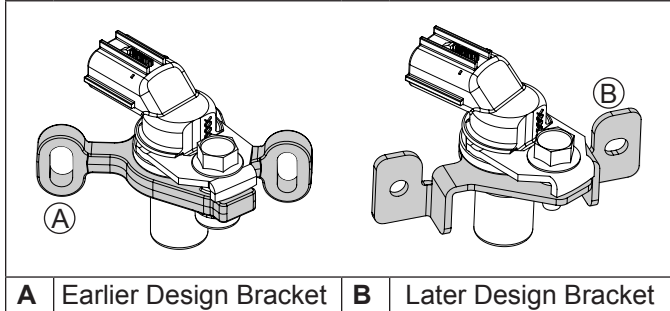

A sealed, non-serviceable assembly. If Fault Code diagnosis indicates a problem within this area, test and correct as follows.

- Check mounting and air gap of crankshaft position sensor.
Earlier design bracket has slots to set air gap of 0.20-0.70 mm (0.008-0.027 in.).
Later design bracket is not adjustable, but if gap is greater than 2.794 mm (0.110 in.) check bracket or sensor for damage.
- Inspect wiring and connections for damage or problems.
- Make sure engine has resistor type spark plugs.
- Disconnect Black connector from ECU.
- Connect an ohmmeter between #4 and #13 pin terminals. A resistance value of 325-395 Ω at room temperature (20°C, 68°F) should be obtained. If resistance is correct, check mounting, air gap, flywheel teeth (damage, run-out, etc.), and flywheel key.
- Disconnect crankshaft position sensor connector from wiring harness. Test resistance between terminals. A reading of 325-395 Ω should again be obtained.
 - If resistance is incorrect, remove screws securing sensor to mounting bracket and replace sensor.
 - If resistance in step 5 was incorrect, but resistance of sensor alone was correct, test wire harness circuits between sensor connector terminals and corresponding pin terminals (#4 and #13) in main connector. Correct any observed problem, reconnect sensor, and perform step 5 again.
- When fault is corrected and engine starts, clear fault codes following ECU Reset procedure.

Throttle Position Sensor (TPS)

Earlier engines were built with a contacting (brush) type TPS. Later engines are built with a contactless (magnet) type TPS. Both designs have same three wires attached; a 5 volt supply, a ground, and a signal wire. However, these designs are not interchangeable. Follow proper testing information based on sensor type.

Contacting (Brush) Type TPS Resistance Table

Throttle Position	Between Terminal	Resistance Value (Ω)	Continuity
Closed	A & C	1400-1800	Yes
Full with Stop Pin	A & C	3200-4100	Yes
Full without Stop Pin	A & C	4600-5200	Yes
Any	A & B	3000-7000	Yes

TPS is a sealed, non-serviceable assembly. If diagnosis indicates a bad sensor, complete replacement is necessary. If a blink code indicates a problem with TPS, it can be tested as follows:

- Counting number of turns, back out idle speed adjusting screw (counterclockwise) until throttle plates can be closed completely. Write this number down for reference later.
- Disconnect Black connector from ECU, but leave TPS mounted to throttle body.
- Use an ohmmeter and connect red (positive) ohmmeter lead to Black pin 12 terminal and black (negative) ohmmeter lead to Black pin 10 terminal to test.
 - Hold throttle closed and check resistance. It should be 1400-1800 Ω .
- Leave leads connected to pin terminals as described in step 3. Rotate throttle shaft slowly to full throttle position. Monitor dial during rotation for indication of any momentary short or open circuits. Note resistance at full throttle position. It should be 4600-5200 Ω without a stop pin, or 3200-4100 Ω with a stop pin.
- Disconnect main wiring harness connector from TPS, leaving TPS assembled to throttle body. Refer to Resistance Table and perform resistance checks indicated between terminals in TPS switch, with throttle in positions specified.
If resistance values in steps 3, 4, and 5 are within specifications, go to step 6.
If resistance values are not within specifications, or a momentary short or open circuit was detected during rotation (step 4), TPS needs to be replaced, go to step 7.
- Check TPS circuits (input, ground) between TPS plug and main harness connector for continuity, damage, etc. Input pin is 12 and ground is pin 10.
 - Repair or replace as required.
 - Turn idle speed screw back in to its original setting.
 - Reconnect connector plugs, start engine and retest system operation.

EFI SYSTEM-ECH WITH OXYGEN SENSOR

7. Remove two mounting screws from TPS. Save screws for reuse. Remove and discard faulty TPS. Install replacement TPS and secure with original mounting screws.
 - a. Reconnect Black and TPS connector plugs.
 - b. Perform TPS Learn Procedure integrating new sensor to ECU.

Contactless (Magnet) Type TPS

TPS is a sealed, non-serviceable assembly. If diagnosis indicates a bad sensor, complete replacement is necessary. Magnet that sensor detects is separate, and can be replaced or reused. If a blink code indicates a problem with TPS, it can be tested as follows:

Diagnostics of sensor: ECU will still have electrical faults captured in fault codes: P0122 & P0123. These electrical faults still have same meaning as with prior sensor, P0122 detecting low voltage, open circuit, and P0123 for high voltage conditions between ECU, wire harness, and sensor. Tip: when working with any electrical connection, remember to keep connections clean & dry. This is best accomplished by cleaning connection thoroughly prior to disassembly. Contaminated sensor connections can cause premature engine faults. Functionally testing sensor can no longer be done with simple resistance checks. If either of these two faults is present or a TPS fault is suspected, recommended diagnostic test is as follows:

If a computer with diagnostic software is available

Observe throttle percent and raw TPS values through diagnostic software. With diagnostic software communicating to ECU and key ON engine not running, these values can be observed while throttle is moved from closed to full open position. There should be a smooth and repeatable throttle percent value starting at closed position reading between 0 (about 6.5%) to WOT position reading 93 (100%). If one of these values is outside of specified range and output transitions in a smooth manner, reset ECU and run test again. Since there is no longer any wear elements inside sensor, most likely faults will be in electrical connections between sensor and wire harness and wire harness to ECU. With service software communicating to ECU and engine not running, a small load or gentle back and forth motion can be applied to connectors or wires just outside connectors to detect a faulty connection.

If only a volt meter is available

Measure voltage supply to sensor from ECU. This voltage should be 5.00 +/- 0.20 volts. This can be measured by gently probing terminals B & C on harness side with TPS connector removed from TPS and key ON. This will generate a P0122 fault that can be cleared with an ECU reset. If voltage is low, battery, harness and ECU should be investigated. If supply voltage is good, plug sensor back into harness. Probe sensor signal wire with volt meter, terminal A at TPS or pin Black 12 at ECU. This signal should start between 0.6-1.2 volts at low idle and grow smoothly as throttle is opened to 4.3-4.8 volts at full open (WOT). Since there is no longer any wear elements inside sensor, most likely faults will be in electrical connections between sensor and wire harness and wire harness to ECU.

Replace Magnet Assembly

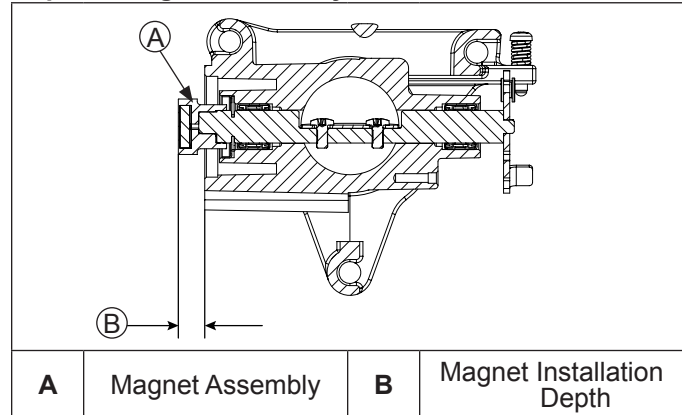

Magnet assembly is captured in a small plastic housing that is press fit to end of throttle shaft. This generally does not need replacement. If replacement is required, can be replaced as follows:

1. Remove sensor from throttle body, exposing round magnet assembly.
2. A pair of flat blade screw drivers or a spanner tool can be used to pry this off shaft. Caution should be used to avoid damage to machined flat surface that sensor seals against. Also, make sure throttle blade is in full open position to avoid driving throttle blade into throttle bore causing damage to blade and/or bore.
3. When replacing magnet assembly, alignment is critical. There is a D-shaped drive feature on end of shaft and a matching pocket in magnet assembly. On outer diameter of magnet assembly is a notch that aligns with center of flat feature of D. Align this notch and flat of D feature in shaft and preassemble parts.
4. With throttle blade in full open position (WOT), press magnet assembly fully on to throttle shaft. Full insertion can be checked by measuring height from throttle body sensor mounting face to end of magnet assembly. This should be no more than 8.6 mm (0.338 in.). Installation process requires significant force, so take care that all parts are aligned. Tapping magnet assembly on can fracture/damage brittle magnet within assembly and throttle body assembly and is NOT RECOMMENDED.

Engine Temperature Sensor

A sealed, non-serviceable assembly. A faulty sensor must be replaced. If a blink code indicates a problem with temperature sensor, it can be tested as follows:

1. Remove temperature sensor from breather cover and cap or block sensor hole.
2. Wipe sensor clean and allow it to reach room temperature (25°C, 77°F).
3. Unplug Black connector from ECU.
4. With sensor still connected, check temperature sensor circuit resistance between Black pin 10 and 14 terminals. Value should be 9000-11000 Ω.
5. Unplug sensor from wire harness and check sensor resistance separately across two pins. Resistance value should again be 9000-11000 Ω.
 - a. If resistance is out of specifications, replace temperature sensor.
 - b. If it is within specifications, proceed to Step 6.
6. Check circuits (input, ground), from wire harness connector to sensor plug for continuity, damage, etc. Connect one ohmmeter lead to Black pin 14 in wire harness connector (as in step 4). Connect other lead to terminal #1 in sensor plug. Continuity should be indicated. Repeat test between Black pin 10 and terminal #2 in sensor plug.

Earlier engines have a separate intake air temperature (IAT) sensor (located in throttle body) and a manifold absolute pressure (MAP) sensor (located in intake manifold).

Intake Air Temperature Sensor

A non-serviceable component. Complete replacement is required if it is faulty. Sensor and wiring harness can be checked as follows.

1. Remove temperature sensor from throttle body.
2. Allow it to reach room temperature (20°C, 68°F).
3. Unplug Black connector from ECU.
4. With sensor still connected, check temperature sensor circuit resistance between Black pin 10 and 8 pin terminals. Value should be 3100-3900 Ω.
5. Unplug sensor from wire harness and check sensor resistance separately across two pins. Resistance value should again be 3100-3900 Ω.
 - a. If resistance is out of specifications, replace temperature sensor.
 - b. If it is within specifications, proceed to Step 6.
6. Check circuits (input, ground), from main harness connector to sensor plug for continuity, damage, etc. Connect one ohmmeter lead to Black pin 8 in main harness connector (as in step 4). Connect other lead to terminal #1 in sensor plug. Continuity should be indicated. Repeat test between Black pin 10 and terminal #2 in sensor plug.

Manifold Absolute Pressure Sensor (MAP)

A sealed, non-serviceable assembly. A faulty sensor must be replaced. If a blink code indicates a problem with manifold absolute pressure sensor, it can be tested as follows:

1. Make sure all connections are making proper contact and are free of dirt and debris. Remove blower housing. Slide locking tab out and pull off manifold absolute pressure connector. Turn key switch to ON and check with a volt meter by contacting red lead to pin 1 and black lead to pin 2. There should be 5 volts present, indicating ECU and wiring harness are functioning.
2. Check continuity in wire harness. Ohms between Pin 3 at sensor connector and Black pin 11 connector at ECU should be near zero ohms. If no continuity is measured or very high resistance, replace wire harness.
3. Check to make sure intake manifold is not loose and MAP sensor is not loose. Loose parts would allow a vacuum leak, making MAP sensor report misleading information to ECU.
 - a. Tighten all hardware and perform an ECU Reset and a TPS Learn Procedure to see if MIL will display a fault with MAP sensor again. If MIL finds a fault with MAP sensor, replace it.

Later engines have a combined temperature/manifold absolute pressure (TMAP) sensor (located in intake manifold).

Temperature/Manifold Absolute Pressure (TMAP) Sensor

A sealed non-serviceable integrated sensor that checks both intake air temperature and manifold absolute pressure. Complete replacement is required if it is faulty. Sensor and wiring harness can be checked as follows.

If a blink code indicates a problem with Intake Air Temperature (TMAP) Sensor Circuit (P0112 or P0113), it can be tested as follows:

1. Remove TMAP sensor from intake manifold.
2. Allow it to reach room temperature (20°C, 68°F).
3. Unplug Black connector from ECU.
4. With sensor still connected, check temperature sensor circuit resistance between Black pin 10 and 8 pin terminals. Value should be 1850-2450 Ω.
5. Unplug sensor from wire harness and check sensor resistance separately across pin. Resistance value should again be 1850-2450 Ω.
 - a. If resistance is out of specifications, check local temperature. Sensor resistance will go down as temperature is higher. Replace TMAP sensor if determined to be faulty.
 - b. If it is within specifications, proceed to Step 6.

EFI SYSTEM-ECH WITH OXYGEN SENSOR

6. Check circuits (input, ground), from main harness connector to sensor plug for continuity, damage, etc. Connect one ohmmeter lead to Black pin 8 in main harness connector (as in step 4). Connect other lead to terminal #3 in sensor plug. Continuity should be indicated. Repeat test between Black pin 10 and terminal #4 in sensor plug.
7. Reinstall sensor.

If a blink code indicates a problem with Manifold Absolute Pressure (TMAP) Sensor Circuit (P0107 or P0108), it can be tested as follows:

1. Make sure all connections are making proper contact and are free of dirt and debris. Slide locking tab out and pull off TMAP connector. Turn key switch to ON and check with a volt meter by contacting red lead to pin 1 and black lead to pin 2. There should be 5 volts present, indicating ECU and wiring harness are functioning.
2. Check continuity in wire harness. Ohms between Pin 3 at sensor connector and Black pin 11 connector at ECU should be near zero ohms. If no continuity is measured or very high resistance, replace wire harness.
3. Check to make sure intake manifold is not loose and TMAP sensor is not loose. Loose parts would allow a vacuum leak, making TMAP sensor report misleading information to ECU.
 - a. Tighten all hardware and perform an ECU Reset and a TPS Learn Procedure to see if MIL will display a fault with sensor again. If MIL finds a fault with TMAP sensor, replace it.

Oxygen Sensor (O₂)

Components

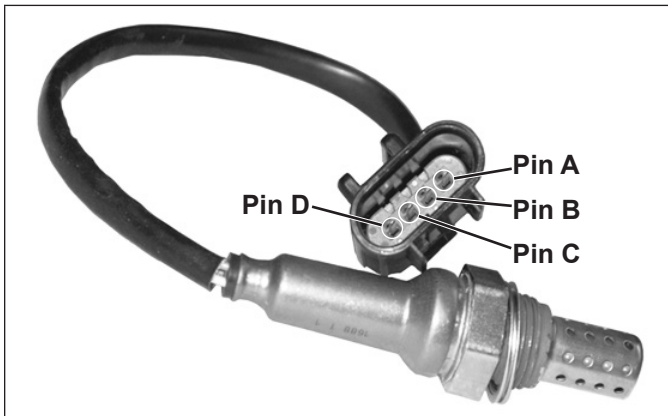

Cutaway Oxygen Sensor Components (O₂)

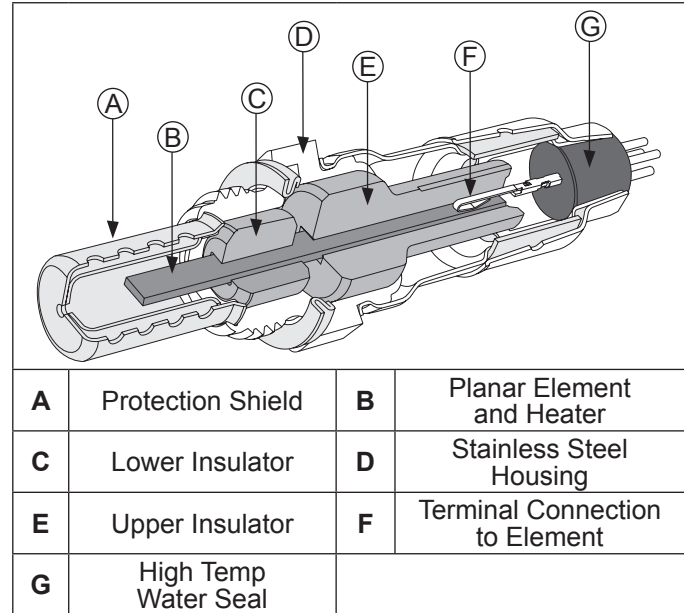

Temperature must be controlled very accurately and gas constituents measured to a high degree of accuracy for absolute sensor measurements. This requires laboratory equipment to determine a good or bad sensor in field. Furthermore, as with most devices, intermittent problems are difficult to diagnose. Still, with a good understanding of system and sensor, it is possible to diagnose many sensor problems in field.

Using diagnostic software connected to ECU is a useful technique for observing sensor performance. However, user must understand that such software reads a signal generated by ECU. If there is an ECU or wiring problem, readings could be misinterpreted as a sensor problem. Digital nature of signal to software means that it is not reading continuous output of sensor. A voltmeter can also be used as an effective tool in diagnosing sensors. It is advisable to use an electronic meter such as a digital voltmeter. Simple mechanical meters may place a heavy electrical load on sensor and cause inaccurate readings. Since resistance of sensor is highest at low temperatures, such meters will cause largest inaccuracies when sensor is in a cool exhaust.

Visual Inspection

1. Look for a damaged or disconnected sensor-to-engine harness connection.
2. Look for damage to sensor lead wire or associated engine wiring due to cutting, chaffing or melting on a hot surface.
3. Disconnect sensor connector and look for corrosion in connector.
4. Try reconnecting sensor and observe if problem has cleared.
5. Correct any problems found during visual check.

EFI SYSTEM-ECH WITH OXYGEN SENSOR

Sensor Signal Observation

NOTE: **Do not cut into or pierce sensor or engine wiring to make this connection.** Sensor produces a very small signal. Corrosion or damage to wiring could lead to an incorrect signal because of repairs or contamination to sensor.

1. Using a voltmeter, observe voltage between Pin C and Pin D before engine is started. With key ON, and sensor unplugged, voltage should read about 5.0 volts. With sensor attached, using diagnostic software, voltage should read about 1.0 volt. This voltage is generated by ECU. If it is not present, there is a short in associated wiring and corrective action should be taken. If voltage still is not present, there is a problem with ECU or engine harness.
2. Reconnect sensor and start engine. Run engine at sufficient speed to bring sensor up to operating temperature. Maintain for 1 to 2 minutes to ensure that engine has gone closed loop. Once in closed loop, sensor voltage should cycle between about 100 to 250 mv (low speed idle) and 700 to 900 mv (high speed no load). If this cycling is not observed, a determination must be made, if problem is with engine or sensor.
3. Check engine harness for battery voltage on heater circuit.

Removal Inspection

NOTE: Apply anti-seize compound only to threads. **Anti-seize compound will affect sensor performance if it gets into lower shield of sensor.**

1. If sensor has heavy deposits on lower shield, engine, oil, or fuel may be source.
2. If heavy carbon deposits are observed, incorrect engine fuel control may be occurring.
3. If sensor is at room temperature, measure between signal leads, black wire (Pin C) and grey wire (Pin D) attached to sensor. If resistance is less than one megohm, sensor has an internal short.
4. With sensor at room temperature measure heater circuit resistance, purple wire (Pin A) and white wire (Pin B), resistance should be 8.1-11.1 Ω .
5. If a damaged sensor is found, identify root cause, which may be elsewhere in application. Refer to Troubleshooting-Oxygen Sensor (O₂) table.
6. A special "dry to touch" anti-seize compound is applied to all new oxygen sensors at factory. If recommended mounting thread sizes are used, this material provides excellent anti-seize capabilities and no additional anti-seize is needed. If sensor is removed from engine and reinstalled, anti-seize compound should be reapplied. Use an oxygen sensor safe type anti-seize compound. It should be applied according to directions on label.



EFI SYSTEM-ECH WITH OXYGEN SENSOR

Troubleshooting-Oxygen Sensor (O₂)

Condition	Possible Cause	Conclusion
Low voltage output.	Shorted sensor or sensor circuit. Shorted lead wire. Wiring shorted to ground.	Replace sensor or repair wiring.
	Contamination of air reference.	Remove source of external contamination, protect air reference area.
	Air leak at sensor or gasket, sensor upper shield damage.	Use recommended torque at installation, replace gasket or sensor. Revise application exhaust. Shield sensor from damage.
High voltage output.	Silica poisoning.	Replace sensor.
	Contaminated gasoline.	Use high quality fuel.
	Engine problem; misfire.	Correct cause of misfire.
	Excessive rich air/fuel ratio.	Check for high fuel pressure. Leaking injector. Liquid fuel in vent line.
	Wiring shorted to voltage.	Repair wiring.
Open circuit, no activity from sensor.	Broken element. Sensor dropped. Hard blow to engine or exhaust system. Defective sensor. Thermal shock.	Replace sensor.
Slow time response.	Open heater circuit. Improper handling. Carbon deposits.	Replace sensor.
	Improper fueling.	Correct fueling.
	Incorrect or contaminated fuel.	Use high quality fuel.
	Excessive engine oil consumption causing exhaust contamination or other exhaust side contamination.	Correct engine condition.
	Heater circuit open/shorted or out of specification.	Repair short in harness wires, replace sensor.

EFI SYSTEM-ECH WITH OXYGEN SENSOR

Fuel Injectors

	 WARNING
	<p>Explosive Fuel can cause fires and severe burns.</p> <p>Fuel system ALWAYS remains under HIGH PRESSURE.</p>
<p>Wrap a shop towel completely around fuel pump module connector. Press release button(s) and slowly pull connector away from fuel pump module allowing shop towel to absorb any residual fuel in high pressure fuel line. Any spilled fuel must be completely wiped up immediately.</p>	

Details

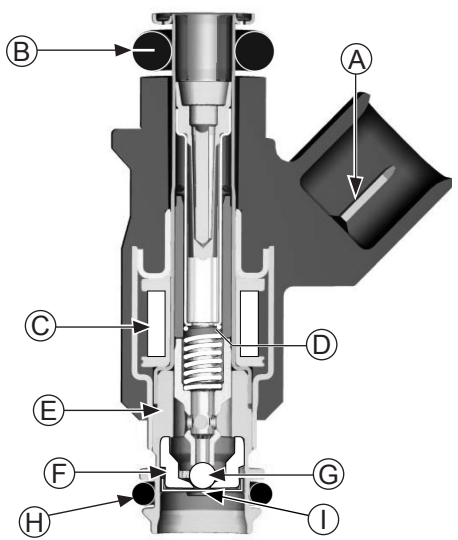

A	Electrical Connection	B	Upper O-ring
C	Solenoid Winding	D	Armature
E	Valve Housing	F	Valve Seat
G	Valve End	H	Lower O-ring
I	Director Plate		

NOTE: Do not apply voltage to fuel injector(s). Excessive voltage will burn out injector(s). Do not ground injector(s) with ignition ON. Injector(s) will open/turn on if relay is energized.

NOTE: When cranking engine with injectors disconnected, fault codes will be registered in ECU and will need to be cleared using software fault clear or an ECU Reset and TPS Learn Procedure.

Injector problems typically fall into three general categories: electrical, dirty/clogged, or leakage. An electrical problem usually causes one or both of injectors to stop functioning. Several methods may be used to check if injectors are operating.

1. With engine running at idle, listen for a buzzing or clicking sound.
2. Disconnect electrical connector from an injector and listen for a change in idle performance (only running on one cylinder) or a change in injector noise or vibration.

If an injector is not operating, it can indicate either a bad injector, or a wiring/electrical connection problem. Check as follows:

1. Disconnect electrical connector from both injectors. Plug a 12 volt noid light into one connector.
2. Make sure all safety switch requirements are met. Crank engine and check for flashing of test light. Turn key OFF for at least 10 seconds between tests to allow ECU to go to sleep and reawake. Repeat test at other connector.
 - a. If flashing occurs, use an ohmmeter (Rx1 scale) and check resistance of each injector across two terminals. Proper resistance is 11-13 Ω . If injector resistance is correct, check whether connector and injector terminals are making a good connection. If resistance is not correct, replace injector.

Check all electrical connections, connectors, and wiring harness leads if resistance is incorrect.

Injector leakage is very unlikely, but in those rare instances it can be internal (past tip of valve needle), or external (weeping around injector O-rings). Loss of system pressure from leakage can cause hot restart problems and longer cranking times. To check for leakage it will be necessary to loosen or remove blower housing which may involve removing engine from unit. Refer to Disassembly for removal of injector.

1. Remove manifold mounting bolts and separate throttle body/manifold from engine leaving TPS, high pressure fuel line, injectors and fuel line connections intact. Discard old gaskets.
2. Position manifold assembly over an appropriate container to capture fuel and turn key switch ON to activate fuel pump and pressurize system. Do not turn switch to START position.

NOTE: Fuel pump module pins are coated with a thin layer of electrical grease to prevent fretting and corrosion. Do not attempt to remove electrical grease from fuel pump module pins.

3. If either injector exhibits leakage of more than two to four drops per minute from tip, or shows any sign of leakage around outer shell, turn ignition switch OFF and replace injector as follows.
4. Depressurize fuel system.
5. Clean any dirt accumulation from sealing/mounting area of faulty injector(s) and disconnect electrical connector(s).
6. Pull retaining clip off top of injector(s). Remove screw holding injector(s) from manifold.

EFI SYSTEM-ECH WITH OXYGEN SENSOR

7. Reverse appropriate procedures to install new injector(s) and reassemble engine. Use new O-rings and retaining clips any time an injector is removed (new replacement injectors include new O-rings and retaining clips). Lubricate O-rings lightly with clean engine oil. Use installation tool provided with O-rings to install new upper O-ring. Place tool into fuel injector inlet. Place one side of O-ring into O-ring groove and roll O-ring over tool onto fuel injector. Torque screw securing fuel injector caps and blower housing mounting screws to 7.3 N·m (65 in. lb.), and intake manifold and air cleaner mounting screws to 10.5 N·m (93 in. lb.). An ECU Reset will need to be completed.

Injector problems due to dirt or clogging are generally unlikely due to design of injectors, high fuel pressure, and detergent additives in gasoline. Symptoms that could be caused by dirty/clogged injectors include rough idle, hesitation/stumbling during acceleration, or triggering of fault codes related to fuel delivery. Injector clogging is usually caused by a buildup of deposits on director plate, restricting flow of fuel, resulting in a poor spray pattern. Some contributing factors to injector clogging include higher than normal operating temperatures, short operating intervals, and dirty, incorrect, or poor quality fuel. Cleaning of clogged injectors is not recommended; they should be replaced. Additives and higher grades of fuel can be used as a preventative measure if clogging has been a problem.

Ignition Coil

If a coil is determined to be faulty, replacement is necessary. An ohmmeter may be used to test wiring and coil windings.

NOTE: Do not ground primary coil with ignition ON as they may overheat or spark.

NOTE: Always disconnect spark plug lead from spark plug before performing following tests.

NOTE: **If ignition coil(s) are disabled and an ignition fault is registered, system will automatically disable corresponding fuel injector drive signal.** Fault must be corrected to ignition coil and ECU power (switch) must be turned OFF for 10 seconds for injector signal to return. This is a safety measure to prevent bore washing and oil dilution.

Testing

Using an ohmmeter set on Rx1 scale, check resistance in circuits as follows:

1. To check cylinder coil 1 (starter side), disconnect Black connector from ECU and test between Black pins 1 and 15. To check cylinder coil 2 (oil filter side), disconnect Grey connector from ECU and test between Grey pins 10 and 17. Wiring and coil primary circuits are OK if readings are 0.5-0.8 Ω .
2. If reading(s) are not within specified range, check and clean connections and retest.
3. If reading(s) are still not within specified range, test coils separately from main harness as follows:
 - a. Remove screw retaining coil to housing and disconnect primary leads connector.

- b. Connect an ohmmeter set on Rx1 scale to primary terminals of coil. Primary resistance should be 0.5-0.8 Ω .
- c. Connect an ohmmeter set on Rx10K scale between spark plug boot terminal and B+ primary terminal. Secondary resistance should be 6400-7800 Ω .
- d. If secondary resistance is not within specified range, coil is faulty and needs to be replaced.

FUEL COMPONENTS

	WARNING
	Explosive Fuel can cause fires and severe burns. Fuel system ALWAYS remains under HIGH PRESSURE.
Wrap a shop towel completely around fuel pump module connector. Press release button(s) and slowly pull connector away from fuel pump module allowing shop towel to absorb any residual fuel in high pressure fuel line. Any spilled fuel must be completely wiped up immediately.	

Fuel Pump Module (FPM)

Fuel pump module is not serviceable and must be replaced if determined to be faulty. If a fuel pump problem is suspected, make certain pump is being activated, all electrical connections are properly secured, fuses are good, and a minimum of 7.0 volts is being supplied. If during cranking, voltage drops below 7.0 volts, a reduction of fuel pressure may occur resulting in a lean starting condition. If required, testing of fuel pump may be conducted.

1. Relieve fuel pressure at fuel pump module. Fuel pump module may need to be loosened or pulled away from engine. Disconnect fuel coupler from fuel pump module and insert pressure test jumper (from Rehiko EFI Service Kit) between high pressure fuel line and fuel pump module.
2. Connect black hose of Pressure Tester. Route clear hose into a portable gasoline container or equipment fuel tank.
3. Turn on key switch to activate pump and check system pressure on gauge. It may take several key cycles to compress air introduced into system and reach regulated pressure. If system pressure of 39 psi \pm 3 is observed, wiring, fuel pump, and regulator are working properly. Turn key switch OFF and depress valve button on tester to relieve system pressure.
 - a. If pressure is too high or too low, replace fuel pump module.
4. If pump did not activate (step 3), disconnect plug from fuel pump. Connect a DC voltmeter across terminals in plug, turn on key switch and observe if a minimum of 7 volts is present during six second prime process.
5. If no voltage is observed, connect red lead of meter to red wire of plug and black lead to a good ground while key is still ON.

EFI SYSTEM-ECH WITH OXYGEN SENSOR

6. If voltage is between 7 and 14, turn key switch OFF and connect an ohmmeter between terminals on pump to check for continuity.
 - a. If there was no continuity between pump terminals, replace fuel pump.
 - b. If voltage was below 7, test wiring harness.
7. If voltage at plug was good, and there was continuity across pump terminals, reconnect plug to pump, making sure you have a good connection. Turn on key switch and listen for pump to activate.
 - a. If pump starts, repeat steps 2 and 3 to verify correct pressure.
 - b. If pump still does not operate, replace it.

High Pressure Fuel Line

High pressure fuel line is mounted to intake manifold. No specific servicing is required unless operating conditions indicate that it needs replacement. Thoroughly clean area around all joints and relieve any pressure before starting any disassembly. Detach by removing two mounting screws, wire ties, and injector retaining clips.

Purge Port and Vent Hose Assembly

No specific servicing is required for vent hose assembly or purge port unless operating conditions indicate replacement is required. All components are serviced individually. Abrasion sleeves on hoses should be reused or replaced when servicing vent hoses. Please note vent hose routing and replicate after service or component replacement to prevent pinching or abrasion of vent hoses. Only Rehlko replacement parts can be used because fitting is specific to system and must be maintained. Visit Engines.rehlko.com for recommended Rehlko replacement parts.

Throttle Body/Intake Manifold Assembly

NOTE: ECU Reset is required if throttle body is replaced.

Throttle body is serviced as an assembly, with throttle shaft, TPS, throttle plate, and idle speed adjusting screw installed. Throttle shaft rotates on needle bearings (non-serviceable), capped with seals to prevent air leaks.

TROUBLESHOOTING

Troubleshooting Guide

Condition	Possible Cause
Engine Starts Hard or Fails to Start When Cold.	Fuel pump not running.
	Faulty spark plugs.
	Old/stale fuel.
	Incorrect fuel pressure.
	Crankshaft position sensor loose or faulty.
	TPS set incorrect (ECU Reset and TPS Learn).
	TPS faulty.
	Engine temp sensor faulty.
	Faulty coils.
	Low system voltage.
	Faulty injectors.
	Faulty battery.
Loose or corroded connections.	

EFI SYSTEM-ECH WITH OXYGEN SENSOR

Troubleshooting Guide

Condition	Possible Cause
Engine Starts Hard or Fails to Start When Hot.	Faulty spark plugs.
	Fuel pump not running.
	Fuel pressure low.
	Insufficient fuel delivery.
	TPS set incorrect (ECU Reset and TPS Initialization).
	Crankshaft position sensor loose or faulty.
	TPS faulty.
	Engine temp sensor faulty.
Engine Stalls or Idles Roughly (cold or warm).	Faulty spark plugs.
	Insufficient fuel delivery.
	TPS set incorrect.
	TPS faulty.
	Faulty engine temperature sensor.
Engine Misses, Hesitates, or Stalls Under Load.	Fuel injector(s), fuel filter, fuel line, or fuel pick-up dirty/restricted.
	Dirty air cleaner.
	Insufficient fuel pressure or fuel delivery.
	Vacuum (intake air) leak.
	Improper governor setting, adjustment or operation.
	TPS faulty, mounting problem or TPS Initialization Procedure incorrect.
Low Power	Bad coil(s), spark plug(s), or wires.
	Faulty/malfunctioning ignition system.
	Dirty air filter.
	Insufficient fuel delivery.
	Improper governor adjustment.
	Plugged/restricted exhaust.
	One injector not working.
	Basic engine problem exists.
TPS faulty or mounting exists.	
Throttle plate in throttle body not fully opening to WOT stop (if equipped).	

EFI SYSTEM-ECH WITH OXYGEN SENSOR

Function Test

	WARNING
	<p>High Pressure Fluids can puncture skin and cause severe injury or death.</p> <p>Do not work on fuel system without proper training or safety equipment.</p>
<p>Fluid puncture injuries are highly toxic and hazardous. If an injury occurs, seek immediate medical attention.</p>	

Function of fuel system is to provide sufficient delivery of fuel at system operating pressure of 39 psi ± 3. If an engine starts hard, or turns over but will not start, it may indicate a problem with EFI fuel system. A quick test will verify if system is operating.

1. Disconnect and ground spark plug leads.
2. Complete all safety interlock requirements and crank engine for approximately 3 seconds.
3. Remove spark plugs and check for fuel at tips.
 - a. If there is fuel at tips of spark plugs fuel pump and injectors are operating.
 - b. If there is no fuel at tips of spark plugs, check following:
 1. Make sure fuel tank contains clean, fresh, proper fuel.
 2. Make sure that vent in fuel tank is open.
 3. Make sure fuel tank valve (if equipped) is fully opened.
 4. Make sure battery is supplying proper voltage.
 5. Check that fuses are good, and that no electrical or fuel line connections are damaged or broken.
 6. Test fuel pump module operation as described earlier under Fuel Pump.

Fault Codes

Example of Diagnostic Display

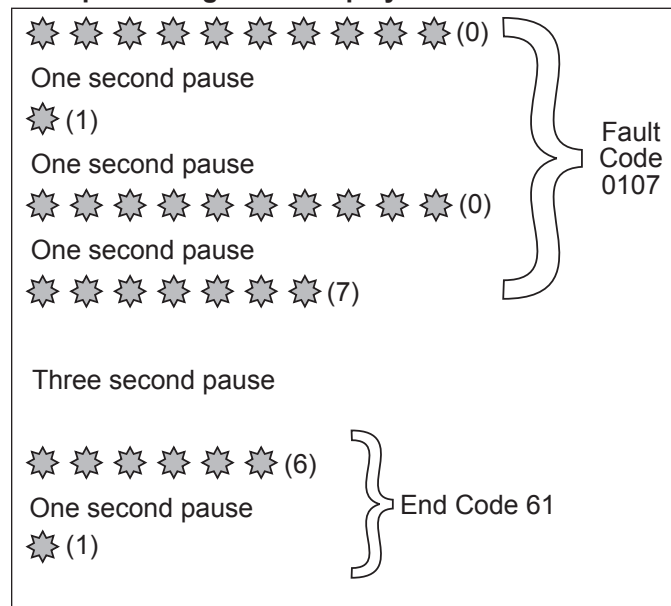

Diagnostic Fault Code Summary

Fault Code	Connection or Failure Description
0031	Oxygen Sensor Heater Circuit Low Voltage
0032	Oxygen Sensor Heater Circuit High Voltage
0107	Manifold Absolute Pressure (MAP or TMAP) Sensor Circuit Low Voltage or Open
0108	Manifold Absolute Pressure (MAP or TMAP) Sensor Circuit High Voltage
0112	Intake Air Temperature (IAT or TMAP) Sensor Circuit Low Voltage
0113	Intake Air Temperature (IAT or TMAP) Sensor Circuit High Voltage or Open
0117	Coolant/Oil Temperature Sensor Circuit Low Voltage
0118	Coolant/Oil Temperature Sensor Circuit High Voltage or Open
0122	Throttle Position Sensor Circuit Low Voltage or Open
0123	Throttle Position Sensor Circuit High Voltage
0131	Oxygen Sensor 1 Circuit Low Voltage, or Open
0132	Oxygen Sensor 1 Circuit High Voltage
0171	Maximum Adaptation Limit Exceeded
0172	Minimum Adaptation Limit Exceeded
0174	Lean Fuel Condition at High Load (Open Loop)
0201	Injector 1 Circuit Malfunction
0202	Injector 2 Circuit Malfunction

EFI SYSTEM-ECH WITH OXYGEN SENSOR

0230	Fuel Pump Module Circuit Low Voltage or Open
0232	Fuel Pump Module Circuit High Voltage
0336	Crankshaft Position Sensor Noisy Signal
0337	Crankshaft Position Sensor No Signal
0351	Cylinder 1 Ignition Coil Malfunction
0352	Cylinder 2 Ignition Coil Malfunction
0562	System Voltage Low
0563	System Voltage High
61	End of Code Transmission

ECU continuously monitors engine operation against preset performance limits. If operation is outside limits, ECU activates MIL, if equipped, and stores a diagnostic code in its fault memory. If component or system returns to proper function, ECU will turn off MIL. If MIL stays illuminated, it warns customer a fault is currently happening, and dealer service is required. Upon receipt, dealer technician can access fault code(s) to help determine what portion of system is malfunctioning.

Codes are accessed through key switch and displayed as blinks or flashes of MIL. Access codes as follows:

1. Check that battery voltage is above 11 volts.
2. Start with key switch OFF.
3. Turn key switch to ON and OFF, then ON and OFF, then ON, leaving it on in third sequence. Do not start engine. Time between sequences must be less than 2.5 seconds.
4. MIL will blink a series of times. Number of times MIL blinks represents a number in blink code.
5. A sequence of four digits make up a fault code. There is a one (1) second pause between blinks of a fault code. There is a three (3) second pause between separate fault codes. After fault code(s) are blinked a two digit 61 is blinked to indicate program has completed.
 - a. It's a good idea to write down codes as they appear, as they may not be in numerical sequence.
 - b. Code 61 will always be last code displayed, indicating end of code transmission. If code 61 appears immediately, no other fault codes are present.

After problem has been corrected, fault codes may be cleared by following ECU Reset and TPS Learn Procedures.

Diagnostic Fault Code Summary lists fault codes, and what they correspond to. Diagnostic Code Summary is a list of individual codes with an explanation of what triggers them, what symptoms might be expected, and probable causes.

A MIL may not be provided with engine. If equipment manufacturer has not added a MIL to equipment, one can be added easily for quick diagnostics. Main engine to vehicle connection will have a tan wire which is ground for MIL. Either incandescent or LED type bulbs can be used for MIL as long as they do not draw more than 0.1 amps. Bulb needs to be rated at 1.4 Watts or less, or needs to have a total resistance of 140 Ω or more. LEDs typically draw less than 0.03 amps. Attach +12 volts to positive terminal of bulb and attach ground terminal of bulb to tan wire.

Diagnostic Code Summary

Code 0031

Component:	Oxygen Sensor Heater
Fault:	O2S Heater Circuit Low Voltage
Condition:	System voltage too low, open connection or faulty sensor.
Conclusion:	<p>Engine Wiring Harness Related</p> <ul style="list-style-type: none"> ● Pin circuit wiring or connectors. ECU black pin 7 or broken wire. <p>Oxygen Sensor Related</p> <ul style="list-style-type: none"> ● Sensor connector or wiring problem. <p>Poor system ground from ECU to engine or battery to engine.</p>

Code 0032

Component:	Oxygen Sensor Heater
Fault:	O2S Heater Circuit High Voltage
Condition:	System voltage too high, shorted connection or faulty sensor.
Conclusion:	<p>Oxygen Sensor Related</p> <ul style="list-style-type: none"> ● Sensor connector or wiring problem. ● Sensor damaged. ● Pin circuit wiring or connectors at Black 7. <p>ECU Related</p> <ul style="list-style-type: none"> ● ECU-to-harness connection problem.

EFI SYSTEM-ECH WITH OXYGEN SENSOR

Code 0107

Component:	Manifold Absolute Pressure (MAP or TMAP) Sensor
Fault:	MAP or TMAP Circuit Low Voltage or Open
Condition:	Intake manifold leak, open connection or faulty sensor.
Conclusion:	<p>MAP or TMAP Sensor Related</p> <ul style="list-style-type: none"> • Sensor malfunction. • Vacuum leaks from loose manifold or sensor. <p>Wire Harness Related</p> <ul style="list-style-type: none"> • Poor grounding or open circuit. • Wire harness and connectors loose, damaged or corroded. • Pin circuit wiring or connectors at Black 10, 11 and 16. <p>Bad TPS Learn.</p>

Code 0108

Component:	Manifold Absolute Pressure (MAP or TMAP) Sensor
Fault:	MAP or TMAP Circuit High Voltage
Condition:	Intake manifold leak, shorted connection or faulty sensor.
Conclusion:	<p>MAP or TMAP Sensor Related</p> <ul style="list-style-type: none"> • Sensor malfunction. • Vacuum leaks from loose manifold or sensor. <p>Wire Harness Related</p> <ul style="list-style-type: none"> • Poor grounding. • Pin circuit wiring or connectors at Black 11. <p>Bad TPS Learn.</p>

Code 0112

Component:	Intake Air Temperature (IAT or TMAP) Sensor
Fault:	Intake Air Temperature (IAT or TMAP) Sensor Circuit Low Voltage
Condition:	Shorted connection, faulty sensor or shorted wire.
Conclusion:	<p>Temperature (IAT or TMAP) Sensor Related</p> <ul style="list-style-type: none"> • Sensor wiring or connection. <p>Engine Wiring Harness Related</p> <ul style="list-style-type: none"> • Pin circuits Black 10 and Black 8 may be damaged or routed near noisy signal (coils, alternator, etc.). • ECU-to-harness connection problem.

Code 0113

Component:	Intake Air Temperature (IAT or TMAP) Sensor
Fault:	Intake Air Temperature (IAT or TMAP) Sensor Circuit High Voltage or Open
Condition:	Shorted connection, faulty sensor, broken wire or connection.
Conclusion:	<p>Temperature (IAT or TMAP) Sensor Related</p> <ul style="list-style-type: none"> • Sensor wiring or connection. <p>Engine Wiring Harness Related</p> <ul style="list-style-type: none"> • Pin circuits ECU Black pin 10 and 8 may be damaged. • ECU-to-harness connection problem or broken wire.

Code 0117

Component:	Coolant/Oil Sensor
Fault:	Coolant/Oil Temperature Sensor Circuit Low Voltage
Condition:	Shorted connection, faulty sensor or shorted wire.
Conclusion:	<p>Temperature Sensor Related</p> <ul style="list-style-type: none"> • Sensor wiring or connection. <p>Engine Wiring Harness Related</p> <ul style="list-style-type: none"> • Pin circuits Black 10 and Black 14 maybe damaged or routed near noisy signal (coils, stator, etc.). • ECU-to-harness connection problem.

Code 0118

Component:	Coolant/Oil Sensor
Fault:	Coolant/Oil Temperature Sensor Circuit High Voltage or Open
Condition:	Shorted connection, faulty sensor, open connection or broken wire.
Conclusion:	<p>Temperature Sensor Related</p> <ul style="list-style-type: none"> • Sensor wiring or connection. <p>Engine Wiring Harness Related</p> <ul style="list-style-type: none"> • Pin circuits ECU Black pin 10 and 14 may be damaged. • ECU-to-harness connection problem or broken wire. <p>System Related</p> <ul style="list-style-type: none"> • Engine is operating above 176°C (350°F) temperature sensor limit.

EFI SYSTEM-ECH WITH OXYGEN SENSOR

Code 0122

Component:	Throttle Position Sensor (TPS)
Fault:	TPS Circuit Low Voltage or Open
Condition:	Open connection, broken wire or faulty sensor.
Conclusion:	<p>TPS Related</p> <ul style="list-style-type: none"> • TPS bad or worn internally. <p>Engine Wiring Harness Related</p> <ul style="list-style-type: none"> • Broken or shorted wire in harness. <ul style="list-style-type: none"> ECU Black pin 10 to TPS pin 1. ECU Black pin 12 to TPS pin 3. ECU Black pin 16 to TPS pin 2. <p>Throttle Body Related</p> <ul style="list-style-type: none"> • Throttle shaft inside TPS worn, broken, or damaged. • Throttle plate loose or misaligned. • Throttle plate bent or damaged allowing extra airflow past, or restricting movement. <p>ECU Related</p> <ul style="list-style-type: none"> • Circuit providing voltage or ground to TPS damaged. • TPS signal input circuit damaged.

Code 0123

Component:	Throttle Position Sensor (TPS)
Fault:	TPS Circuit High Voltage
Condition:	Shorted connection or faulty sensor.
Conclusion:	<p>TPS Sensor Related</p> <ul style="list-style-type: none"> • Sensor connector or wiring. • Sensor output affected or disrupted by dirt, grease, oil, wear. • Sensor loose on throttle body manifold. <p>Throttle Body Related</p> <ul style="list-style-type: none"> • Throttle shaft or bearings worn/damaged. <p>Engine Wiring Harness Related</p> <ul style="list-style-type: none"> • ECU pins Black 10, 12 and 16 damaged (wiring, connectors). • ECU pins Black 10, 12 and 16 routed near noisy electrical signal (coils, alternator). • Intermittent 5 volt source from ECU (pin Black 16). • ECU-to-harness connection problem.

Code 0131

Component:	Oxygen Sensor
Fault:	O2S 1 Circuit Low Voltage
Condition:	Open connection, broken wire or faulty sensor.
Conclusion:	<p>Oxygen Sensor Related</p> <ul style="list-style-type: none"> • Sensor connector or wiring problem. • Sensor contaminated, corroded or damaged. • Poor ground path. • Pin circuit wiring or connectors. <ul style="list-style-type: none"> ECU Black pin 10 or 17. <p>TPS Learn Procedure Incorrect</p> <ul style="list-style-type: none"> • Lean condition (check oxygen sensor signal with VOA and see Oxygen Sensor). <p>Engine wiring harness related such as a cut wire, broken or pinched.</p>

Code 0132

Component:	Oxygen Sensor
Fault:	O2S 1 Circuit High Voltage
Condition:	Shorted connection or faulty sensor.
Conclusion:	<p>Oxygen Sensor Related</p> <ul style="list-style-type: none"> • Sensor connector or wiring problem. • Sensor contaminated or damaged. • Poor ground path. • Pin circuit wiring or connectors. <ul style="list-style-type: none"> ECU Black pin 10 or Black pin 17. <p>Engine Wiring Harness Related</p> <ul style="list-style-type: none"> • Difference in voltage between sensed voltage and actual sensor voltage. • Short in wire harness.

EFI SYSTEM-ECH WITH OXYGEN SENSOR

Code 0171

Component:	Fuel System
Fault:	Maximum adaptation limit exceeded
Condition:	Fuel inlet screen/filter plugged, low pressure at high pressure fuel line, TPS malfunction, shorted connection, faulty sensor, low fuel or wrong fuel type.
Conclusion:	<p>Oxygen Sensor Related</p> <ul style="list-style-type: none"> ● Corrosion or poor connection. ● Sensor contaminated or damaged. ● Air leak into exhaust. ● Poor ground path. ● Pin circuit wiring or connectors. ECU Black pin 10 or Black pin 17. <p>TPS Sensor Related</p> <ul style="list-style-type: none"> ● Throttle plate position incorrect during Learn procedure. ● TPS problem or malfunction. <p>Engine Wiring Harness Related</p> <ul style="list-style-type: none"> ● Difference in voltage between sensed voltage and actual sensor voltage. ● Problem in wiring harness. ● ECU-to-harness connection problem. <p>Systems Related</p> <ul style="list-style-type: none"> ● Ignition (spark plug, plug wire, ignition coil). ● Fuel (fuel type/quality, injector, fuel pressure too low, fuel pump module or lift pump). ● Combustion air (air cleaner dirty/restricted, intake leak, throttle bores). ● Base engine problem (rings, valves). ● Exhaust system leak (muffler, flange, oxygen sensor mounting boss, etc.). ● Fuel in crankcase oil.

Code 0172

Component:	Fuel System
Fault:	Minimum adaptation limit exceeded
Condition:	Too high pressure at high pressure fuel line, TPS malfunction, shorted connection, faulty sensor or fuel pump module failure.
Conclusion:	<p>Oxygen Sensor Related</p> <ul style="list-style-type: none"> ● Sensor connector or wiring. ● Sensor contaminated or damaged. ● Poor ground path. ● Pin circuit wiring or connectors. ECU Black pin 10 or 17. <p>TPS Sensor Related</p> <ul style="list-style-type: none"> ● Throttle plate position incorrect during Learn procedure. ● TPS problem or malfunction. <p>Engine Wiring Harness Related</p> <ul style="list-style-type: none"> ● Difference in voltage between sensed voltage and actual sensor voltage. ● Problem in wiring harness. ● ECU-to-harness connection problem. <p>Systems Related</p> <ul style="list-style-type: none"> ● Ignition (spark plug, plug wire, ignition coil). ● Fuel (fuel type/quality, injector, fuel pressure too high, fuel pump module or lift pump). ● Combustion air (air cleaner dirty/restricted). ● Base engine problem (rings, valves). ● Fuel in crankcase oil. ● Fuel pump module is over filled. ● Lift pump diaphragm is ruptured.

EFI SYSTEM-ECH WITH OXYGEN SENSOR

Code 0174

Component:	Fuel System
Fault:	Lean fuel condition
Condition:	Fuel inlet screen/filter plugged, low pressure at high pressure fuel line, TPS malfunction, shorted connection or faulty sensor.
Conclusion:	<p>TPS Learn Incorrect</p> <ul style="list-style-type: none"> Lean condition (check oxygen sensor signal with VOA and see Oxygen Sensor). <p>Engine Wiring Harness Related</p> <ul style="list-style-type: none"> Pin circuit wiring or connectors. ECU pin Black 10, 12, 16 and 17. <p>Low Fuel Pressure</p> <ul style="list-style-type: none"> Plugged filters. Bad lift pump. <p>Oxygen Sensor Related</p> <ul style="list-style-type: none"> Sensor connector or wiring problem. Exhaust leak. Poor ground. <p>Poor system ground from ECU to engine, causing rich running while indicating lean.</p> <p>Fuel pump module connection. See Fuel Components.</p>

Code 0201

Component:	Fuel Injector
Fault:	Injector 1 Circuit Malfunction
Condition:	Injector damaged or faulty, shorted or open connection.
Conclusion:	<p>Injector Related</p> <ul style="list-style-type: none"> Injector coil shorted or opened. <p>Engine Wiring Harness Related</p> <ul style="list-style-type: none"> Broken or shorted wire in harness. ECU pin Black 5. Wiring from Ignition. <p>ECU Related</p> <ul style="list-style-type: none"> Circuit controlling injector #1 damaged.

Code 0202

Component:	Fuel Injector
Fault:	Injector 2 Circuit Malfunction
Condition:	Injector damaged or faulty, shorted or open connection.
Conclusion:	<p>Injector Related</p> <ul style="list-style-type: none"> Injector coil shorted or opened. <p>Engine Wiring Harness Related</p> <ul style="list-style-type: none"> Broken or shorted wire in harness. ECU pin Black 6. Wiring from Ignition. <p>ECU Related</p> <ul style="list-style-type: none"> Circuit controlling injector #2 damaged.

Code 0230

Component:	Fuel Pump
Fault:	Circuit Low Voltage or Open
Condition:	Shorted or open connection.
Conclusion:	<p>Fuel Pump Related</p> <ul style="list-style-type: none"> Fuel pump module open or shorted internally. <p>Engine Wiring Harness related</p> <ul style="list-style-type: none"> Broken or shorted wire in harness. ECU pin Black 9 or Grey 17. <p>ECU Related</p> <ul style="list-style-type: none"> ECU is damaged.

Code 0232

Component:	Fuel Pump
Fault:	Circuit High Voltage
Condition:	Shorted connection.
Conclusion:	<p>Fuel Pump Related</p> <ul style="list-style-type: none"> Fuel pump module damaged internally. <p>Charging Output System Too High.</p>

EFI SYSTEM-ECH WITH OXYGEN SENSOR

Code 0336

Component:	Crankshaft Position Sensor
Fault:	Crankshaft Position Sensor Noisy Signal
Condition:	Air gap incorrect, loose sensor, faulty/bad battery, shorted or faulty connection, faulty sensor or faulty sensor grounding.
Conclusion:	<p>Crankshaft Position Sensor Related</p> <ul style="list-style-type: none"> • Sensor connector or wiring. • Sensor loose or air gap incorrect. <p>Crankshaft Position Sensor Wheel Related</p> <ul style="list-style-type: none"> • Damaged teeth. • Gap section not registering. <p>Engine Wiring Harness Related</p> <ul style="list-style-type: none"> • Pin circuit wiring or connectors. ECU pin Black 4 and Black 13. • ECU-to-harness connection problem. <p>Ignition System Related</p> <ul style="list-style-type: none"> • Non-resistor spark plug(s) used. • Faulty or disconnected ignition coil or secondary lead.

Code 0337

Component:	Crankshaft Position Sensor
Fault:	Crankshaft Position Sensor No Signal
Condition:	Air gap incorrect, loose sensor, open or shorted connection or faulty sensor.
Conclusion:	<p>Crankshaft Position Sensor Related</p> <ul style="list-style-type: none"> • Sensor connector or wiring. • Sensor loose or air gap incorrect. <p>Crankshaft Position Sensor Wheel Related</p> <ul style="list-style-type: none"> • Damaged teeth. <p>Engine Wiring Harness Related</p> <ul style="list-style-type: none"> • Pin circuit wiring or connectors. ECU pin Black 4 or Black 13. • ECU-to-harness connection problem. <p>If code is stored in fault history and starts normally. Clear code, no other service required.</p>

Code 0351

Component:	Ignition Coil
Fault:	Cylinder 1 Ignition Coil Malfunction
Condition:	Broken wire in harness (may not be visible), shorted connection or faulty sensor.
Conclusion:	<p>Engine Wiring Harness Related</p> <ul style="list-style-type: none"> • Connection to ignition or fuse. • Pin circuit wiring or connectors. • ECU pin Black 1. • ECU-to-harness connection problem. <p>Ignition System Related</p> <ul style="list-style-type: none"> • Incorrect spark plug(s) used. • Poor connection to spark plug.

Code 0352

Component:	Ignition Coil
Fault:	Cylinder 2 Ignition Coil Malfunction
Condition:	Broken wire in harness (may not be visible), shorted connection or faulty sensor.
Conclusion:	<p>Engine Wiring Harness Related</p> <ul style="list-style-type: none"> • Connection to ignition or fuse. • Pin circuit wiring or connectors. ECU pin Grey 10. • ECU-to-harness connection problem. <p>Ignition System Related</p> <ul style="list-style-type: none"> • Incorrect spark plug(s) used. • Poor connection to spark plug.

Code 0562

Component:	System Voltage
Fault:	System Voltage Low
Condition:	Faulty voltage regulator, bad fuse or shorted connection.
Conclusion:	<p>Corroded Connections</p> <p>Bad Stator</p> <p>Bad Battery</p> <ul style="list-style-type: none"> • Low output charging system. • Poor magnet in flywheel. • Bad or missing fuse.

Code 0563

Component:	System Voltage
Fault:	System Voltage High
Condition:	Faulty voltage regulator or shorted connection.
Conclusion:	<p>Faulty Rectifier-Regulator</p> <p>Bad Stator.</p> <p>Bad Battery.</p>

Code 61

Component:	End of Code Transmission
------------	--------------------------

EFI SYSTEM-ECH WITH OXYGEN SENSOR

Troubleshooting Flow Chart

Following flow chart provides an alternative method of troubleshooting EFI system. Chart will enable you to review entire system in about 10-15 minutes. Using chart, accompanying diagnostic aids (listed after chart), and any signaled fault codes, you should be able to quickly locate any problems within system.

Flow Chart Diagnostic Aids

Diagnostic Aid #1 SYSTEM POWER

(MIL does not illuminate when key is turned ON)

NOTE: MIL is installed by vehicle OEM. Twelve volt supply to bulb will be part of vehicle wire harness. Rehlko key switch model will have MIL on engine with 12V supply to bulb.

Conclusion

- Battery
- Main system fuse
- MIL light bulb burned out
- MIL electrical circuit problem
 - Pin circuits Grey 3.
- Ignition switch
- Permanent ECU power circuit problem
 - Pin circuit Black 18.
- Switched ECU power circuit problem
 - Pin circuit Black 15.
- ECU grounds
- ECU

Diagnostic Aid #2 FAULT CODES

Refer to Diagnostic Fault Code Summary.

Diagnostic Aid #3 RUN/ON

(MIL remains ON while engine is running)*

Condition

NOTE: Either incandescent or LED type bulbs can be used for MIL as long as they do not draw more than 0.1 amps. Bulb needs to be rated at 1.4 Watts or less, or needs to have a total resistance of 140 Ω or more. LEDs typically draw less than 0.03 amps.

*All current fault codes will turn on MIL when engine is running.

Diagnostic Aid #4 CRANKSHAFT POSITION SENSOR

(MIL does not turn off during cranking)

Condition

- Crankshaft position sensor
- Crankshaft position sensor circuit problem, pin circuits Black 4 and Black 13.
- Crankshaft position sensor/toothed wheel air gap
- Toothed wheel
- Flywheel key sheared
- ECU

Diagnostic Aid #5 FUEL PUMP

(fuel pump not turning on)

Condition

- Main fuse
- Fuel pump circuit problem, pin circuits Black 9 and Grey 17.
- Fuel pump module

Diagnostic Aid #6 IGNITION SYSTEM

(no spark)

Condition

- Spark plug
- Plug wire
- Coil
- Coil circuit(s), pin circuits Grey 10 and Black 1.
- ECU grounds
- ECU
- Vehicle safety interlocks, ground signal on safety wire.

Diagnostic Aid #7 FUEL SYSTEM ELECTRICAL

(no fuel delivery)

Condition

- No fuel
- Air in high pressure fuel line
- Fuel valve shut OFF
- Fuel filter/line plugged
- Injector circuit(s), pin circuits Black 5 and Black 6
- Injector
- ECU grounds
- ECU
- Lift pump not working

Diagnostic Aid #8 FUEL SYSTEM

(fuel pressure)

Low Fuel Pressure-Condition

- Low fuel
- Fuel filter plugged
- Fuel supply line plugged
- Lift fuel pump - insufficient fuel supply
- Fuel pump (lift or module) - internally plugged
- Pressure regulator not functioning properly inside fuel pump module.

Diagnostic Aid #9 BASIC ENGINE

(cranks but will not run)

Condition

- Refer to basic engine troubleshooting charts within Troubleshooting.

EFI Diagnostic Flow Diagram

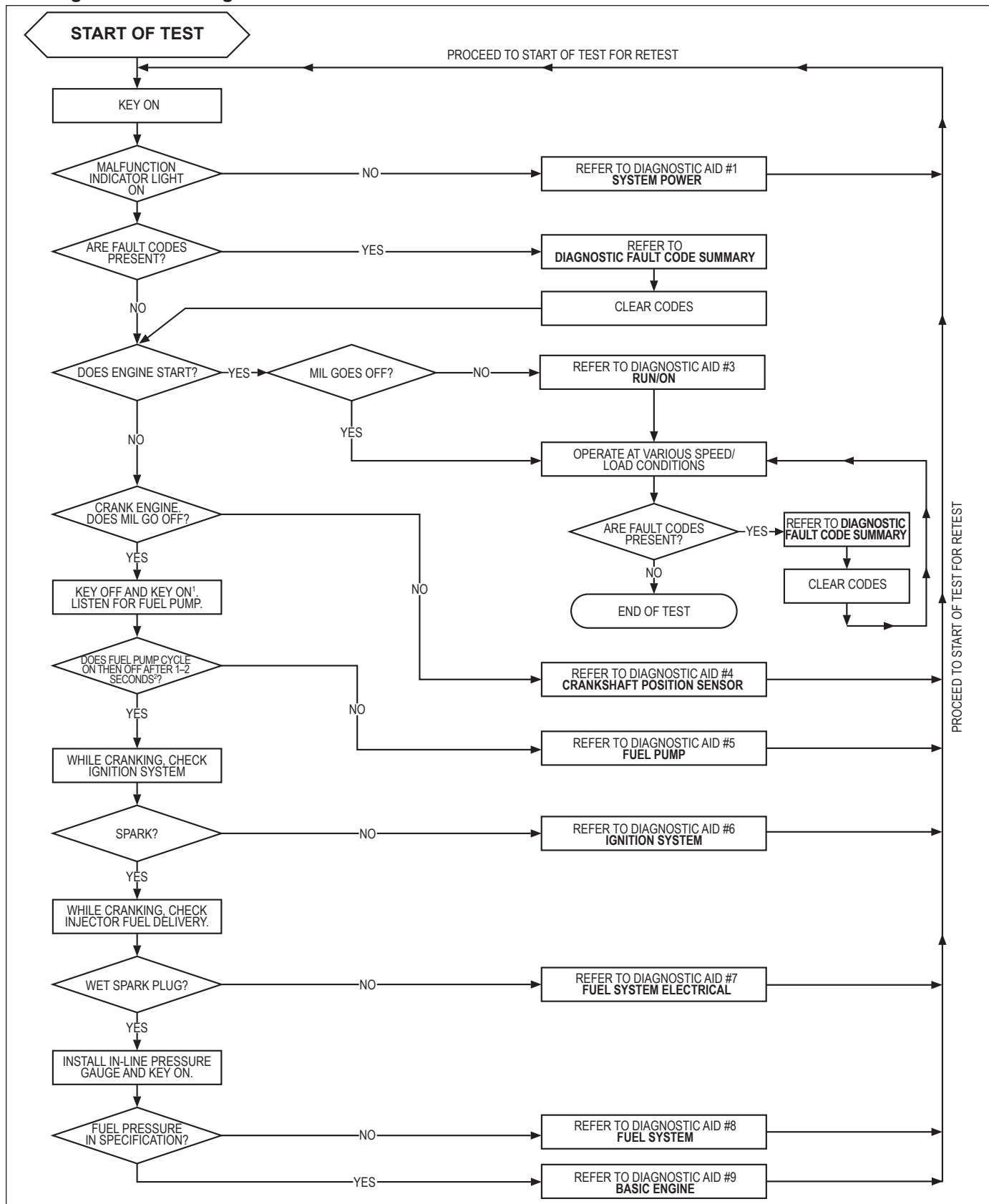

1. After turning key to OFF, wait 10 seconds before turning to ON to allow ECU to go to sleep.
2. Fuel pump module can be heard or a vibration can be felt to establish pump cycle. Fuel pump module will run for one 4-6 second cycle when ECU wakes up after being asleep.

EFI SYSTEM-ECH WITHOUT OXYGEN SENSOR

	⚠ WARNING
	Explosive Fuel can cause fires and severe burns. Do not fill fuel tank while engine is hot or running.
Gasoline is extremely flammable and its vapors can explode if ignited. Store gasoline only in approved containers, in well ventilated, unoccupied buildings, away from sparks or flames. Spilled fuel could ignite if it comes in contact with hot parts or sparks from ignition. Never use gasoline as a cleaning agent.	

NOTE: Engines built from factory without an oxygen sensor are designed without an oxygen sensor. No attempt should be made to install one in this system as it will not function.

Typical electronic fuel injection (EFI) system and related components include:

- Fuel pump module and lift pump.
- Fuel filter.
- High pressure fuel line.
- Fuel line(s).
- Fuel injectors.
- Throttle body/intake manifold.
- Electronic control unit (ECU).
- Ignition coils.
- Engine temperature sensor.
- Throttle position sensor (TPS).
- Crankshaft position sensor.
- Temperature/manifold absolute pressure (TMAP) sensor.
- Malfunction indicator light (MIL) - optional.
- Wire harness assembly & affiliated wiring.

FUEL RECOMMENDATIONS

Refer to Maintenance.

FUEL LINE

Low permeation fuel line must be installed on all Rehlko engines to maintain EPA and CARB regulatory compliance.

OPERATION

NOTE: When performing voltage or continuity tests, avoid putting excessive pressure on or against connector pins. Flat pin probes are recommended for testing to avoid spreading or bending terminals.

EFI system is designed to provide peak engine performance with optimum fuel efficiency and lowest possible emissions. Ignition and injection functions are electronically controlled and monitored.

Central component of system is Electronic Control Unit (ECU) which manages system operation, determining best combination of fuel mixture and ignition timing for current operating conditions.

A lift fuel pump is used to move fuel from tank through an in-line fuel filter and fuel line. Fuel is then pumped to fuel pump module. Fuel pump module regulates fuel pressure to a system operating pressure of 39 psi. Fuel is delivered from fuel pump module through high pressure fuel line into injectors, which inject fuel into intake ports. ECU controls amount of fuel by varying length of time that injectors are on. This can range from 2 to over 12 milliseconds depending on fuel requirements. Controlled injection of fuel occurs every other crankshaft revolution, or once for each 4-stroke cycle. When intake valve opens, air/fuel mixture is drawn into combustion chamber, compressed, ignited, and burned.

ECU controls amount of fuel being injected and ignition timing by monitoring primary sensor signals for engine temperature, speed (RPM), and throttle position (load). These primary signals are compared to preprogrammed maps in ECU computer chip, and ECU adjusts fuel delivery to match mapped values.

During certain operating periods such as cold starts, warm up, acceleration, high load, etc., a richer air/fuel ratio is required and is normal operation.

ECU is brain or central processing computer of entire EFI system. During operation, sensors continuously gather data which is relayed through wiring harness to input circuits within ECU. Signals to ECU include: ignition (on/off), crankshaft position and speed (RPM), throttle position, engine temperature, intake air temperature, manifold absolute pressure, and battery voltage.

ECU compares input signals to programmed maps in its memory to determine appropriate fuel and spark requirements for immediate operating conditions. ECU then sends output signals to set injector duration and ignition timing.

ECU continually performs a diagnostic check of itself, each of sensors, and system performance. If a fault is detected, ECU can turn on a Malfunction Indicator Light (MIL) (if equipped) on equipment control panel, store fault code in its fault memory, and go into a default operating mode. Depending on significance or severity of fault, normal operation may continue. A technician can access stored fault code using a blink code diagnosis flashed out through MIL. An optional computer software diagnostic program is also available, see Tools and Aids.

ECU requires a minimum of 6.0 volts to operate.

To prevent engine over-speed and possible failure, a rev-limiting feature is programmed into ECU. If maximum RPM limit (4500) is exceeded, ECU suppresses injection signals, cutting off fuel flow. This process repeats itself in rapid succession, limiting operation to preset maximum.

EFI SYSTEM-ECH WITHOUT OXYGEN SENSOR

Wiring harness used in EFI system connects electrical components, providing current and ground paths for system to operate. All input and output signaling occurs through two special all weather connectors that attach and lock to ECU. Connectors are Black and Grey and keyed differently to prevent being attached to ECU incorrectly.

Condition of wiring, connectors, and terminal connections is essential to system function and performance. Corrosion, moisture, and poor connections are as likely cause of operating problems and system errors as an actual component. Refer to Electrical System for additional information.

EFI system is a 12 VDC negative ground system, designed to operate down to a minimum of 6.0 volts. If system voltage drops below this level, operation of voltage sensitive components such as ECU, fuel pump, ignition coils, and injectors will be intermittent or disrupted, causing erratic operation or hard starting. A fully charged, 12 volt battery with a minimum of 350 cold cranking amps is important in maintaining steady and reliable system operation. Battery condition and state of charge should always be checked first when troubleshooting an operational problem.

Keep in mind that EFI-related problems are often caused by wiring harness or connections. Even small amounts of corrosion or oxidation on terminals can interfere with milliamp currents used in system operation.

Cleaning connectors and grounds will solve problems in many cases. In an emergency situation, simply disconnecting and reconnecting connectors may clean up contacts enough to restore operation, at least temporarily.

If a fault code indicates a problem with an electrical component, disconnect ECU connector and test for continuity between component connector terminals and corresponding terminals in ECU connector using an ohmmeter. Little or no resistance should be measured, indicating that wiring of that particular circuit is OK.

Crankshaft position sensor is essential to engine operation; constantly monitoring rotation and speed (RPM) of crankshaft. There are 23 consecutive teeth cast into flywheel. One tooth is missing and is used to reference crankshaft position for ECU.

During rotation, an AC voltage pulse is created within sensor for each passing tooth. ECU calculates engine speed from time interval between consecutive pulses. Gap from missing tooth creates an interrupted input signal, corresponding to specific crankshaft position near BDC for cylinder #1. This signal serves as a reference for control of ignition timing by ECU. Synchronization of inductive speed pickup and crankshaft position takes place during first two revolutions each time engine is started. Sensor must be properly connected at all times. If sensor becomes disconnected for any reason, engine will quit running.

Throttle position sensor (TPS) is used to indicate throttle plate angle to ECU. Since throttle (by way of governor) reacts to engine load, angle of throttle plate is directly related to load on engine.

Mounted on throttle body and operated directly off end of throttle shaft, TPS works as a potentiometer, varying voltage signal to ECU in direct correlation to angle of throttle plate. This signal, along with other sensor signals, is processed by ECU and compared to internal preprogrammed maps to determine required fuel and ignition settings for amount of load.

Correct position of TPS is established and set at factory. Do not loosen TPS or alter mounting position unless absolutely required by fault code diagnosis. If TPS is loosened or repositioned, appropriate TPS Learn Procedure must be performed to re-establish baseline relationship between ECU and TPS.

Engine temperature sensor is used by system to help determine fuel requirements for starting (a cold engine needs more fuel than one at or near operating temperature).

Mounted in breather cover, it has a temperature-sensitive resistor that extends into oil flow. Resistance changes with oil temperature, altering voltage sent to ECU. Using a table stored in its memory, ECU correlates voltage drop to a specific temperature. Using fuel delivery maps, ECU then knows how much fuel is required for starting at that temperature.

EFI SYSTEM-ECH WITHOUT OXYGEN SENSOR

Temperature/Manifold Absolute Pressure (TMAP) sensor is an integrated sensor that checks both intake air temperature (IAT) and manifold absolute pressure (MAP).

Intake Air Temperature control is a thermally sensitive resistor that exhibits a change in electrical resistance with a change in its temperature. When sensor is cold, resistance of sensor is high. As sensor warms up, resistance drops and voltage signal increases. From voltage signal, ECU can determine temperature of intake air.

Purpose of sensing air temperature is to help ECU calculate air density. Higher air temperature less dense air becomes. As air becomes less dense ECU knows that it needs to lessen fuel flow to achieve correct air/fuel ratio. If fuel ratio was not changed engine would become rich, possibly losing power and consuming more fuel.

Manifold absolute pressure check provides immediate manifold pressure information to ECU. TMAP sensor measures difference in pressure between outside atmosphere and vacuum level inside intake passage and monitors pressure in passage as primary means of detecting load. Data is used to calculate air density and determine engine's mass air flow rate, which in turn determines required ideal fueling. TMAP also stores instant barometric pressure reading when key is turned ON.

Fuel injectors mount into intake manifold, and high pressure fuel line attaches to them at top end. Replaceable O-rings on both ends of injector prevent external fuel leakage and also insulate it from heat and vibration. A special clip connects each injector to high pressure fuel line and holds it in place. O-rings and retaining clip must be replaced any time fuel injector is separated from its normal mounting position.

When key switch is on, fuel pump module will pressurize high pressure fuel line to 39 psi, and voltage is present at injector. At proper instant, ECU completes ground circuit, energizing injector. Valve needle in injector is opened electromagnetically, and pressure in high pressure fuel line forces fuel down through inside. Director plate at tip of injector contains a series of calibrated openings which directs fuel into manifold in a cone-shaped spray pattern.

Injectors have sequential fueling that open and close once every other crankshaft revolution. Amount of fuel injected is controlled by ECU and determined by length of time valve needle is held open, also referred to as injection duration or pulse width. Time injector is open (milliseconds) may vary in duration depending on speed and load requirements of engine.

A high-voltage, solid-state, battery ignition system is used with EFI system. ECU controls ignition output and timing through transistorized control of primary current delivered to coils. Based on input from crankshaft position sensor, ECU determines correct firing point for speed at which engine is running. At proper instant, it interrupts flow of primary current in coil, causing electromagnetic flux field to collapse. Flux collapse induces an instantaneous high voltage in coil secondary which is strong enough to bridge gap on spark plug. Each coil fires every other revolution.

EFI engines are equipped with either a 20 or 25 amp charging system to accommodate combined electrical demands of ignition system and specific application. Charging system troubleshooting information is provided in Electrical System.

An electric fuel pump module and a lift pump (two types) are used to transfer fuel in EFI system. Types of lift pumps are: a pulse fuel pump, a mechanical fuel pump, or a low pressure electric fuel pump. Pumping action is created by either oscillation of positive and negative pressures within crankcase through a hose, or by direct lever/pump actuation off rocker arm movement. Pumping action causes diaphragm on inside of pump to pull fuel in on its downward stroke and to push it into fuel pump module on its upward stroke. Internal check valves prevent fuel from going backward through pump. Fuel pump module receives fuel from lift pump, increases and regulates pressure for fuel injectors.

Fuel pump module is rated for a minimum output of 13.5 liters per hour and regulated at 270 kilopascals (39 psi).

When key switch is turned ON and all safety switch requirements are met, ECU activates fuel pump module for about six seconds, which pressurizes system for start-up. If key switch is not promptly turned to start position, engine fails to start, or engine is stopped with key switch ON (as in case of an accident), ECU switches off pump preventing continued delivery of fuel. In this situation, MIL will go on, but it will go back off after 4 cranking revolutions if system function is OK. Once engine is running, fuel pump remains on.

Precision components inside fuel pump module are not serviceable. DO NOT attempt to open fuel pump module. Damage to components will result and warranty will be void. Because fuel pump module is not serviceable, engines are equipped with a special 10-micron EFI fuel filter to prevent harmful contamination from entering module.

If there are two filters in system, one before lift pump will be a standard 51-75 micron filter, and one after lift pump will be special 10-micron filter. Be sure to use an approved 10-micron filter for replacement.

EFI SYSTEM-ECH WITHOUT OXYGEN SENSOR

High pressure fuel line is an assembly of hoses, injector caps and a fuel connector to fuel pump module. High pressure fuel line feeds fuel to top of injectors through injector caps. Caps are fastened to intake manifold and injectors are locked into place. A small retaining clip provides a secondary lock.

High pressure fuel line is serviced as a complete assembly to prevent tampering and safety hazards. Components are not individually serviceable.

Vent hose assembly is intended to vent fuel vapor out of fuel pump module and direct fuel vapor into throttle body. Most EFI engines are equipped with an engine mounted purge port on #2 cylinder barrel baffle. This capped purge port can be used by OEM to vent fuel tanks or used in conjunction with a carbon canister kit for Tier III evaporative emissions compliance. Purge port connects to vent hose assembly and directs all fuel vapor into throttle body. If purge port remains unused, port must remain capped to prevent dirt from entering engine.

EFI engines have no carburetor, so throttle function (regulate incoming combustion airflow) is achieved with a throttle valve in a separate throttle body attached to intake manifold. Throttle body/intake manifold provides mounting for fuel injectors, throttle position sensor, TMAP sensor, high pressure fuel line, idle speed screw, and air cleaner assembly.

Idle speed is only adjustment that may be performed on EFI system. Standard idle speed setting for EFI engines is 1500 RPM, but certain applications might require a different setting. Check equipment manufacturer's recommendation.

For starting and warm up, ECU will adjust fuel and ignition timing, based upon ambient temperature, engine temperature, and loads present. In cold conditions, idle speed will probably be different than normal for a few moments. Under other conditions, idle speed may actually start lower than normal, but gradually increase to established setting as operation continues. Do not attempt to circumvent this warm up period, or readjust idle speed during this time. Engine must be completely warmed up for accurate idle adjustment.

IMPORTANT NOTES!

- Cleanliness is essential and must be maintained at all times when servicing or working on EFI system. Dirt, even in small quantities, can cause significant problems.
- Clean any joint or fitting with parts cleaning solvent before opening to prevent dirt from entering system.
- Always depressurize fuel system through fuel connector on fuel pump module before disconnecting or servicing any fuel system components.
- Never attempt to service any fuel system component while engine is running or ignition switch is ON.
- Do not use compressed air if system is open. Cover any parts removed and wrap any open joints with plastic if they will remain open for any length of time. New parts should be removed from their protective packaging just prior to installation.
- Avoid direct water or spray contact with system components.
- Do not disconnect or reconnect ECU wiring harness connector or any individual components with ignition on. This can send a damaging voltage spike through ECU.
- Do not allow battery cables to touch opposing terminals. When connecting battery cables attach positive (+) cable to positive (+) battery terminal first, followed by negative (-) cable to negative (-) battery terminal.
- Never start engine when cables are loose or poorly connected to battery terminals.
- Never disconnect battery while engine is running.
- Never use a quick battery charger to start engine.
- Do not charge battery with key switch ON.
- Always disconnect negative (-) battery cable before charging battery, and also unplug harness from ECU before performing any welding on equipment.

EFI SYSTEM-ECH WITHOUT OXYGEN SENSOR

ELECTRICAL COMPONENTS

Electronic Control Unit (ECU)

Pinout of ECU

Black Connector Side	
Pin #	Function
1	Ignition Coil #1 Ground
2	Battery Ground
3	Diagnostic Communication Line
4	Speed Sensor input
5	Fuel Injector Output #1 Ground
6	Fuel Injector Output #2 Ground
7	INACTIVE Oxygen Sensor Heater
8	Intake Air Temperature (TMAP) sensor input
9	Fuel Pump Ground
10	Ground for TPS, TMAP and Engine Temperature Sensors
11	Manifold Absolute Pressure (TMAP) sensor input
12	Throttle Position Sensor (TPS) input
13	Speed Sensor Ground
14	Engine Temperature Sensor input
15	Ignition Switch (Switched +12V)
16	Power for TPS and TMAP Sensors (+5V)
17	INACTIVE Oxygen Sensor (O2) input
18	Battery Power (Permanent +12V)

Grey Connector Side	
Pin #	Description
1	Not Used
2	Not Used
3	Malfunction Indicator Light (MIL) Ground
4	Not Used
5	Not Used
6	Not Used
7	Not Used
8	Not Used
9	Battery Ground
10	Ignition Coil #2 Ground
11	Not Used
12	Not Used
13	Not Used
14	Safety Switch Ground
15	Not Used
16	ECU
17	Fuel Pump Control (+12V)
18	Not Used

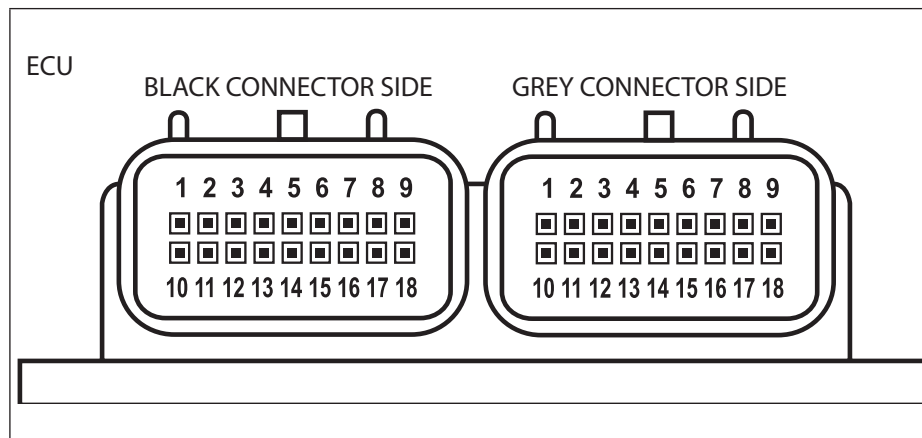

Pinout of ECU

EFI SYSTEM-ECH WITHOUT OXYGEN SENSOR

Never attempt to disassemble ECU. It is sealed to prevent damage to internal components. Warranty is void if case is opened or tampered with in any way.

All operating and control functions within ECU are preset. No internal servicing or readjustment may be performed. If a problem is encountered, and you determine ECU to be faulty, contact your source of supply.

ECU pins are coated at factory with a thin layer of electrical grease to prevent fretting and corrosion. Do not attempt to remove grease from ECU pins.

Relationship between ECU and throttle position sensor (TPS) is very critical to proper system operation. If TPS or ECU is changed, or mounting position of TPS is altered, appropriate TPS Learn Procedure must be performed to restore synchronization.

Any service to ECU, TPS/Throttle Body (including idle speed increase over 300 RPM), or fuel pump module replacement should include ECU Reset.

This will clear all trouble codes, all max values, and all timers besides permanent hour meter.

This system will NOT reset when battery is disconnected!

ECU Reset Procedure

1. Turn key/ignition OFF.
2. Install Red wire jumper from Rehlko EFI service kit on to service port (connect white wire to black wire in 4 way diagnostic port).
3. Turn key/ignition ON, then OFF and count 10 seconds.
4. Turn key/ignition ON, then OFF and count to 10 seconds a second time.
5. Remove Red wire jumper. Turn key/ignition ON, then OFF and count to 10 seconds a third time. ECU is reset.

A TPS Learn Procedure **must** be performed after ECU Reset.

TPS Learn Procedure

1. Turn idle screw clockwise one full turn prior to key/ignition ON after ECU Reset.
2. Start engine, run at low idle until engine is warm.
3. Idle speed must be above 1500 RPM. If below 1500 RPM, turn idle screw up to 1700 RPM and then shut down engine and perform ECU Reset again.
4. Adjust idle speed down to 1500 RPM. Allow engine to dwell at 1500 RPM for about 3 seconds.
5. After this, adjust idle speed to final specified speed setting.
6. Turn key/ignition OFF and count to 10 seconds.

Learn procedure is complete.

EFI SYSTEM-ECH WITHOUT OXYGEN SENSOR

EFI Wiring Diagram 6-Terminal Connector

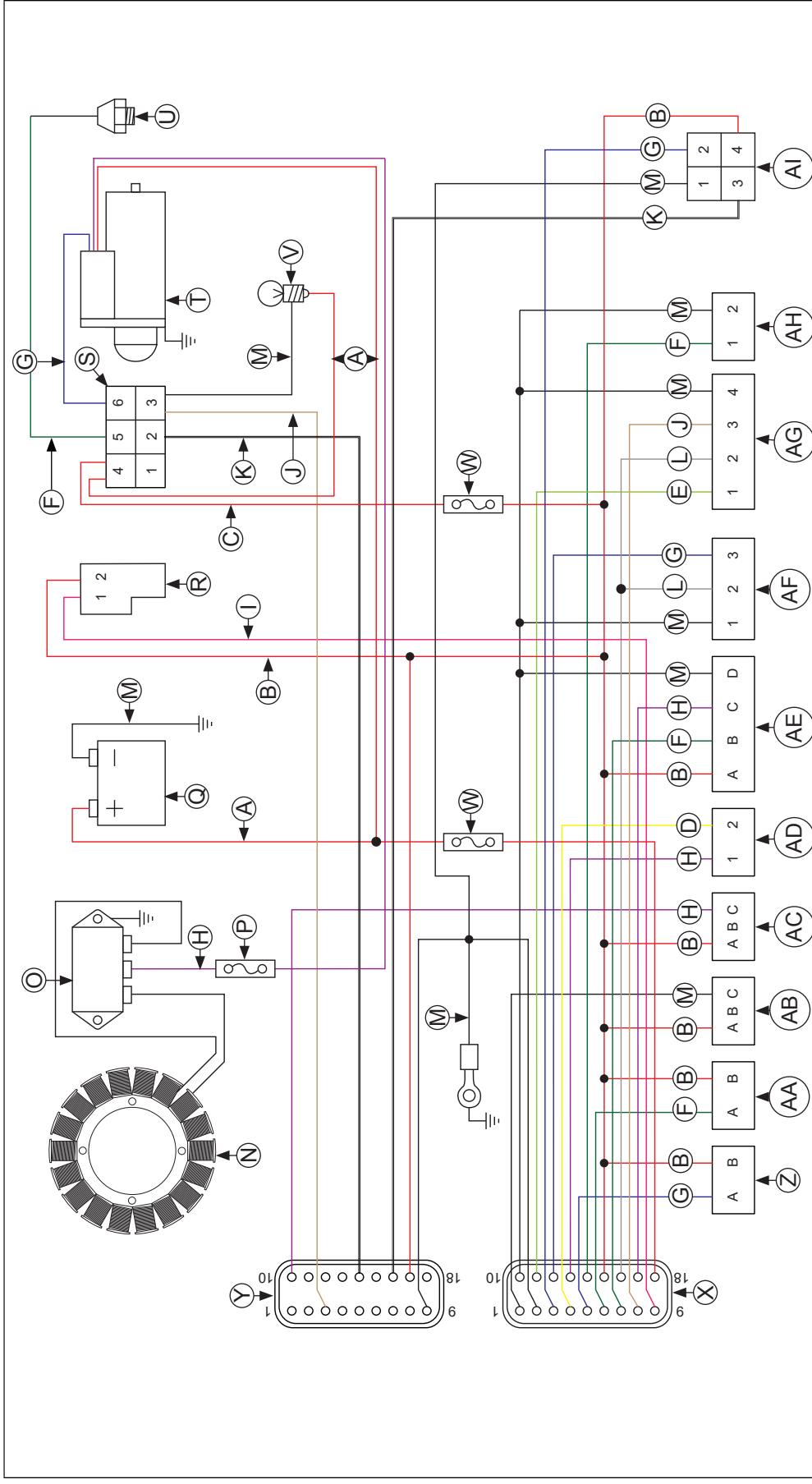

A	Red	B	Red/Black	C	Red/White	D	Yellow	E	Light Green
F	Dark Green	G	Dark Blue	H	Purple	I	Pink	J	Tan
K	White	L	Grey	M	Black	N	Stator	O	Rectifier-Regulator
P	30A Fuse	Q	Battery	R	Fuel Pump	S	6-Terminal Connector	T	Starter Motor
U	Oil Pressure Switch	V	MIL (Optional)	W	10A Fuse	X	Black Connector	Y	Grey Connector
Z	Fuel Injector #1	AA	Fuel Injector #2	AB	Ignition Coil #1	AC	Ignition Coil #2	AD	Crankshaft Position Sensor
AE	Oxygen Sensor Connector is tied off and not used	AF	Throttle Position Sensor	AG	TMAP Sensor	AH	Engine Temperature Sensor	AI	Diagnostic Connector

EFI SYSTEM-ECH WITHOUT OXYGEN SENSOR

Crankshaft Position Sensor

A sealed, non-serviceable assembly. If Fault Code diagnosis indicates a problem within this area, test and correct as follows.

1. Check mounting and air gap of crankshaft position sensor.
Bracket is not adjustable, but if gap is greater than 2.794 mm (0.110 in.) check bracket or sensor for damage.
2. Inspect wiring and connections for damage or problems.
3. Make sure engine has resistor type spark plugs.
4. Disconnect Black connector from ECU.
5. Connect an ohmmeter between #4 and #13 pin terminals. A resistance value of 325-395 Ω at room temperature (20°C, 68°F) should be obtained. If resistance is correct, check mounting, air gap, flywheel teeth (damage, run-out, etc.), and flywheel key.
6. Disconnect crankshaft position sensor connector from wiring harness. Test resistance between terminals. A reading of 325-395 Ω should again be obtained.
 - a. If resistance is incorrect, remove screws securing sensor to mounting bracket and replace sensor.
 - b. If resistance in step 5 was incorrect, but resistance of sensor alone was correct, test wire harness circuits between sensor connector terminals and corresponding pin terminals (#4 and #13) in main connector. Correct any observed problem, reconnect sensor, and perform step 5 again.
7. When fault is corrected and engine starts, clear fault codes following ECU Reset procedure.

Throttle Position Sensor (TPS)

TPS is a sealed, non-serviceable assembly. If diagnosis indicates a bad sensor, complete replacement is necessary. Magnet that sensor detects is separate, and can be replaced or reused. If a blink code indicates a problem with TPS, it can be tested as follows:

Diagnostics of sensor: ECU will still have electrical faults captured in fault codes: P0122 & P0123. P0122 detecting low voltage, open circuit, and P0123 for high voltage conditions between ECU, wire harness, and sensor. Tip: when working with any electrical connection, remember to keep connections clean & dry. This is best accomplished by cleaning connection thoroughly prior to disassembly. Contaminated sensor connections can cause premature engine faults. Functionally testing sensor can no longer be done with simple resistance checks. If either of these two faults is present or a TPS fault is suspected, recommended diagnostic test is as follows:

If a computer with diagnostic software is available

Observe throttle percent and raw TPS values through diagnostic software. With diagnostic software communicating to ECU and key ON engine not running, these values can be observed while throttle is moved from closed to full open position. There should be a smooth and repeatable throttle percent value starting at closed position reading between 0 (about 6.5%) to WOT position reading 93 (100%). If one of these values is outside of specified range and output transitions in a smooth manner, reset ECU and run test again. Since there is no wear elements inside sensor, most likely faults will be in electrical connections between sensor and wire harness and wire harness to ECU. With service software communicating to ECU and engine not running, a small load or gentle back and forth motion can be applied to connectors or wires just outside connectors to detect a faulty connection.

If only a volt meter is available

Measure voltage supply to sensor from ECU. This voltage should be 5.00 +/- 0.20 volts. This can be measured by gently probing terminals B & C on harness side with TPS connector removed from TPS and key ON. This will generate a P0122 fault that can be cleared with an ECU reset. If voltage is low, battery, harness and ECU should be investigated. If supply voltage is good, plug sensor back into harness. Probe sensor signal wire with volt meter, terminal A at TPS or pin Black 12 at ECU. This signal should start between 0.6-1.2 volts at low idle and grow smoothly as throttle is opened to 4.3-4.8 volts at full open (WOT). Since there is no longer any wear elements inside sensor, most likely faults will be in electrical connections between sensor and wire harness and wire harness to ECU.

Replace Magnet Assembly

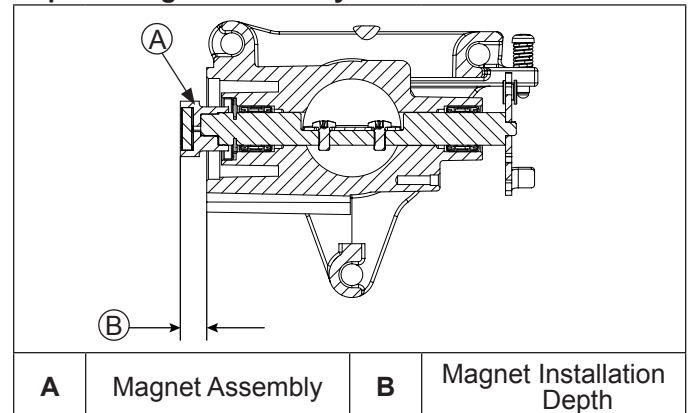

Magnet assembly is captured in a small plastic housing that is press fit to end of throttle shaft. This generally does not need replacement. If replacement is required, can be replaced as follows:

1. Remove sensor from throttle body, exposing round magnet assembly.
2. A pair of flat blade screw drivers or a spanner tool can be used to pry this off shaft. Caution should be used to avoid damage to machined flat surface that sensor seals against. Also, make sure throttle blade is in full open position to avoid driving throttle blade into throttle bore causing damage to blade and/or bore.

EFI SYSTEM-ECH WITHOUT OXYGEN SENSOR

- When replacing magnet assembly, alignment is critical. There is a D-shaped drive feature on end of shaft and a matching pocket in magnet assembly. On outer diameter of magnet assembly is a notch that aligns with center of flat feature of D. Align this notch and flat of D feature in shaft and preassemble parts.
- With throttle blade in full open position (WOT), press magnet assembly fully on to throttle shaft. Full insertion can be checked by measuring height from throttle body sensor mounting face to end of magnet assembly. This should be no more than 8.6 mm (0.338 in.). Installation process requires significant force, so take care that all parts are aligned. Tapping magnet assembly on can fracture/damage brittle magnet within assembly and throttle body assembly and is NOT RECOMMENDED.
- Unplug sensor from wire harness and check sensor resistance separately across pin. Resistance value should again be 1850-2450 Ω .
 - If resistance is out of specifications, check local temperature. Sensor resistance will go down as temperature is higher. Replace TMAP sensor if determined to be faulty.
 - If it is within specifications, proceed to Step 6.
- Check circuits (input, ground), from main harness connector to sensor plug for continuity, damage, etc. Connect one ohmmeter lead to Black pin 8 in main harness connector (as in step 4). Connect other lead to terminal #3 in sensor plug. Continuity should be indicated. Repeat test between Black pin 10 and terminal #4 in sensor plug.
- Reinstall sensor.

Engine Temperature Sensor

A sealed, non-serviceable assembly. A faulty sensor must be replaced. If a blink code indicates a problem with temperature sensor, it can be tested as follows:

- Remove temperature sensor from breather cover and cap or block sensor hole.
- Wipe sensor clean and allow it to reach room temperature (25°C, 77°F).
- Unplug Black connector from ECU.
- With sensor still connected, check temperature sensor circuit resistance between Black pin 10 and 14 terminals. Value should be 9000-11000 Ω .
- Unplug sensor from wire harness and check sensor resistance separately across two pins. Resistance value should again be 9000-11000 Ω .
 - If resistance is out of specifications, replace temperature sensor.
 - If it is within specifications, proceed to Step 6.
- Check circuits (input, ground), from wire harness connector to sensor plug for continuity, damage, etc. Connect one ohmmeter lead to Black pin 14 in wire harness connector (as in step 4). Connect other lead to terminal #1 in sensor plug. Continuity should be indicated. Repeat test between Black pin 10 and terminal #2 in sensor plug.

Temperature/Manifold Absolute Pressure (TMAP) Sensor

A sealed non-serviceable integrated sensor that checks both intake air temperature and manifold absolute pressure. Complete replacement is required if it is faulty. Sensor and wiring harness can be checked as follows.

If a blink code indicates a problem with Intake Air Temperature (TMAP) Sensor Circuit (P0112 or P0113), it can be tested as follows:



- Remove TMAP sensor from intake manifold.
- Allow it to reach room temperature (20°C, 68°F).
- Unplug Black connector from ECU.
- With sensor still connected, check temperature sensor circuit resistance between Black pin 10 and 8 pin terminals. Value should be 1850-2450 Ω .

If a blink code indicates a problem with Manifold Absolute Pressure (TMAP) Sensor Circuit (P0107 or P0108), it can be tested as follows:

- Make sure all connections are making proper contact and are free of dirt and debris. Slide locking tab out and pull off TMAP connector. Turn key switch to ON and check with a volt meter by contacting red lead to pin 1 and black lead to pin 2. There should be 5 volts present, indicating ECU and wiring harness are functioning.
- Check continuity in wire harness. Ohms between Pin 3 at sensor connector and Black pin 11 connector at ECU should be near zero ohms. If no continuity is measured or very high resistance, replace wire harness.
- Check to make sure intake manifold is not loose and TMAP sensor is not loose. Loose parts would allow a vacuum leak, making TMAP sensor report misleading information to ECU.
 - Tighten all hardware and perform an ECU Reset and a TPS Learn Procedure to see if MIL will display a fault with sensor again. If MIL finds a fault with TMAP sensor, replace it.

EFI SYSTEM-ECH WITHOUT OXYGEN SENSOR

Fuel Injectors

	 WARNING
	<p>Explosive Fuel can cause fires and severe burns.</p> <p>Fuel system ALWAYS remains under HIGH PRESSURE.</p>
<p>Wrap a shop towel completely around fuel pump module connector. Press release button(s) and slowly pull connector away from fuel pump module allowing shop towel to absorb any residual fuel in high pressure fuel line. Any spilled fuel must be completely wiped up immediately.</p>	

Details

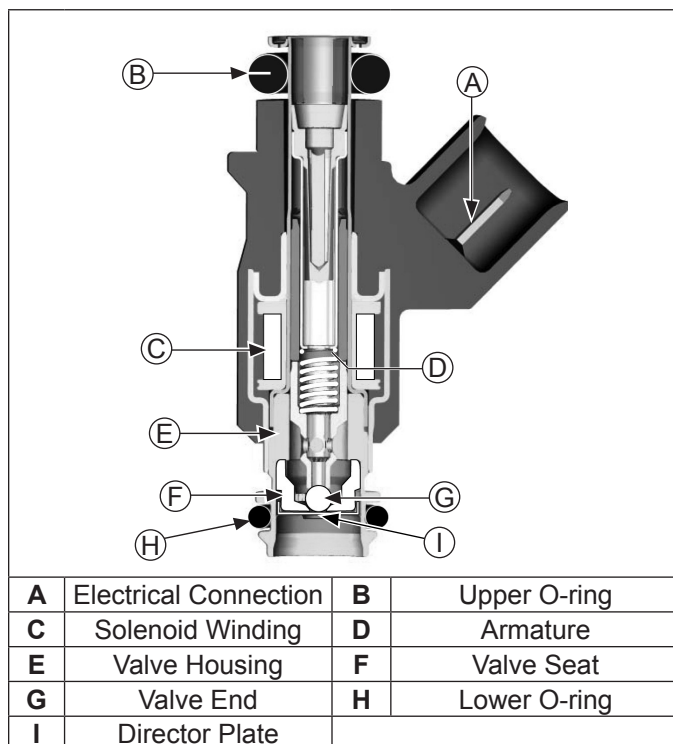

NOTE: Do not apply voltage to fuel injector(s). Excessive voltage will burn out injector(s). Do not ground injector(s) with ignition ON. Injector(s) will open/turn on if relay is energized.

NOTE: When cranking engine with injectors disconnected, fault codes will be registered in ECU and will need to be cleared using software fault clear or an ECU Reset and TPS Learn Procedure.

Injector problems typically fall into three general categories: electrical, dirty/clogged, or leakage. An electrical problem usually causes one or both of injectors to stop functioning. Several methods may be used to check if injectors are operating.

1. With engine running at idle, listen for a buzzing or clicking sound.
2. Disconnect electrical connector from an injector and listen for a change in idle performance (only running on one cylinder) or a change in injector noise or vibration.

If an injector is not operating, it can indicate either a bad injector, or a wiring/electrical connection problem. Check as follows:

1. Disconnect electrical connector from both injectors. Plug a 12 volt noid light into one connector.
2. Make sure all safety switch requirements are met. Crank engine and check for flashing of test light. Turn key OFF for at least 10 seconds between tests to allow ECU to go to sleep and reawake. Repeat test at other connector.
 - a. If flashing occurs, use an ohmmeter (Rx1 scale) and check resistance of each injector across two terminals. Proper resistance is 11-13 Ω . If injector resistance is correct, check whether connector and injector terminals are making a good connection. If resistance is not correct, replace injector.

Check all electrical connections, connectors, and wiring harness leads if resistance is incorrect.

Injector leakage is very unlikely, but in those rare instances it can be internal (past tip of valve needle), or external (weeping around injector O-rings). Loss of system pressure from leakage can cause hot restart problems and longer cranking times. To check for leakage it will be necessary to loosen or remove blower housing which may involve removing engine from unit. Refer to Disassembly for removal of injector.

1. Remove manifold mounting bolts and separate throttle body/manifold from engine leaving TPS, high pressure fuel line, injectors and fuel line connections intact. Discard old gaskets.
2. Position manifold assembly over an appropriate container to capture fuel and turn key switch ON to activate fuel pump and pressurize system. Do not turn switch to START position.

NOTE: Fuel pump module pins are coated with a thin layer of electrical grease to prevent fretting and corrosion. Do not attempt to remove electrical grease from fuel pump module pins.

3. If either injector exhibits leakage of more than two to four drops per minute from tip, or shows any sign of leakage around outer shell, turn ignition switch OFF and replace injector as follows.
4. Depressurize fuel system.
5. Clean any dirt accumulation from sealing/mounting area of faulty injector(s) and disconnect electrical connector(s).
6. Pull retaining clip off top of injector(s). Remove screw holding injector(s) from manifold.

EFI SYSTEM-ECH WITHOUT OXYGEN SENSOR

- Reverse appropriate procedures to install new injector(s) and reassemble engine. Use new O-rings and retaining clips any time an injector is removed (new replacement injectors include new O-rings and retaining clips). Lubricate O-rings lightly with clean engine oil. Use installation tool provided with O-rings to install new upper O-ring. Place tool into fuel injector inlet. Place one side of O-ring into O-ring groove and roll O-ring over tool onto fuel injector. Torque screw securing fuel injector caps and blower housing mounting screws to 7.3 N·m (65 in. lb.), and intake manifold and air cleaner mounting screws to 10.5 N·m (93 in. lb.). An ECU Reset will need to be completed.

Injector problems due to dirt or clogging are generally unlikely due to design of injectors, high fuel pressure, and detergent additives in gasoline. Symptoms that could be caused by dirty/clogged injectors include rough idle, hesitation/stumbling during acceleration, or triggering of fault codes related to fuel delivery. Injector clogging is usually caused by a buildup of deposits on director plate, restricting flow of fuel, resulting in a poor spray pattern. Some contributing factors to injector clogging include higher than normal operating temperatures, short operating intervals, and dirty, incorrect, or poor quality fuel. Cleaning of clogged injectors is not recommended; they should be replaced. Additives and higher grades of fuel can be used as a preventative measure if clogging has been a problem.

Ignition Coil

If a coil is determined to be faulty, replacement is necessary. An ohmmeter may be used to test wiring and coil windings.

NOTE: Do not ground primary coil with ignition ON as they may overheat or spark.

NOTE: Always disconnect spark plug lead from spark plug before performing following tests.

NOTE: **If ignition coil(s) are disabled and an ignition fault is registered, system will automatically disable corresponding fuel injector drive signal.** Fault must be corrected to ignition coil and ECU power (switch) must be turned OFF for 10 seconds for injector signal to return. This is a safety measure to prevent bore washing and oil dilution.

Testing

Using an ohmmeter set on Rx1 scale, check resistance in circuits as follows:

- To check cylinder coil 1 (starter side), disconnect Black connector from ECU and test between Black pins 1 and 15. To check cylinder coil 2 (oil filter side), disconnect Grey connector from ECU and test between Grey pins 10 and 17. Wiring and coil primary circuits are OK if readings are 0.5-0.8 Ω.
- If reading(s) are not within specified range, check and clean connections and retest.
- If reading(s) are still not within specified range, test coils separately from main harness as follows:
 - Remove screw retaining coil to housing and disconnect primary leads connector.

- Connect an ohmmeter set on Rx1 scale to primary terminals of coil. Primary resistance should be 0.5-0.8 Ω.
- Connect an ohmmeter set on Rx10K scale between spark plug boot terminal and B+ primary terminal. Secondary resistance should be 6400-7800 Ω.
- If secondary resistance is not within specified range, coil is faulty and needs to be replaced.

FUEL COMPONENTS

	WARNING
	Explosive Fuel can cause fires and severe burns. Fuel system ALWAYS remains under HIGH PRESSURE.
Wrap a shop towel completely around fuel pump module connector. Press release button(s) and slowly pull connector away from fuel pump module allowing shop towel to absorb any residual fuel in high pressure fuel line. Any spilled fuel must be completely wiped up immediately.	

Fuel Pump Module (FPM)

Fuel pump module is not serviceable and must be replaced if determined to be faulty. If a fuel pump problem is suspected, make certain pump is being activated, all electrical connections are properly secured, fuses are good, and a minimum of 7.0 volts is being supplied. If during cranking, voltage drops below 7.0 volts, a reduction of fuel pressure may occur resulting in a lean starting condition. If required, testing of fuel pump may be conducted.

- Relieve fuel pressure at fuel pump module. Fuel pump module may need to be loosened or pulled away from engine. Disconnect fuel coupler from fuel pump module and insert pressure test jumper (from Rehiko EFI Service Kit) between high pressure fuel line and fuel pump module.
- Connect black hose of Pressure Tester. Route clear hose into a portable gasoline container or equipment fuel tank.
- Turn on key switch to activate pump and check system pressure on gauge. It may take several key cycles to compress air introduced into system and reach regulated pressure. If system pressure of 39 psi ± 3 is observed, wiring, fuel pump, and regulator are working properly. Turn key switch OFF and depress valve button on tester to relieve system pressure.
 - If pressure is too high or too low, replace fuel pump module.
- If pump did not activate (step 3), disconnect plug from fuel pump. Connect a DC voltmeter across terminals in plug, turn on key switch and observe if a minimum of 7 volts is present during six second prime process.

EFI SYSTEM-ECH WITHOUT OXYGEN SENSOR

5. If no voltage is observed, connect red lead of meter to red wire of plug and black lead to a good ground while key is still ON.
6. If voltage is between 7 and 14, turn key switch OFF and connect an ohmmeter between terminals on pump to check for continuity.
 - a. If there was no continuity between pump terminals, replace fuel pump.
 - b. If voltage was below 7, test wiring harness.
7. If voltage at plug was good, and there was continuity across pump terminals, reconnect plug to pump, making sure you have a good connection. Turn on key switch and listen for pump to activate.
 - a. If pump starts, repeat steps 2 and 3 to verify correct pressure.
 - b. If pump still does not operate, replace it.

High Pressure Fuel Line

High pressure fuel line is mounted to intake manifold. No specific servicing is required unless operating conditions indicate that it needs replacement. Thoroughly clean area around all joints and relieve any pressure before starting any disassembly. Detach by removing two mounting screws, wire ties, and injector retaining clips.

Purge Port and Vent Hose Assembly

No specific servicing is required for vent hose assembly or purge port unless operating conditions indicate replacement is required. All components are serviced individually. Abrasion sleeves on hoses should be reused or replaced when servicing vent hoses. Please note vent hose routing and replicate after service or component replacement to prevent pinching or abrasion of vent hoses. Only Rehlko replacement parts can be used because fitting is specific to system and must be maintained. Visit Engines.rehlko.com for recommended Rehlko replacement parts.

Throttle Body/Intake Manifold Assembly

NOTE: ECU Reset is required if throttle body is replaced.

Throttle body is serviced as an assembly, with throttle shaft, TPS, throttle plate, and idle speed adjusting screw installed. Throttle shaft rotates on needle bearings (non-serviceable), capped with seals to prevent air leaks.

TROUBLESHOOTING

Troubleshooting Guide

Condition	Possible Cause
Engine Starts Hard or Fails to Start When Cold.	Fuel pump not running.
	Faulty spark plugs.
	Old/stale fuel.
	Incorrect fuel pressure.
	Crankshaft position sensor loose or faulty.
	TPS set incorrect (ECU Reset and TPS Learn).
	TPS faulty.
	Engine temp sensor faulty.
	Faulty coils.
	Low system voltage.
	Faulty injectors.
	Faulty battery.
Loose or corroded connections.	

EFI SYSTEM-ECH WITHOUT OXYGEN SENSOR

Troubleshooting Guide

Condition	Possible Cause
Engine Starts Hard or Fails to Start When Hot.	Faulty spark plugs.
	Fuel pump not running.
	Fuel pressure low.
	Insufficient fuel delivery.
	TPS set incorrect (ECU Reset and TPS Initialization).
	Crankshaft position sensor loose or faulty.
	TPS faulty.
	Engine temp sensor faulty.
Engine Stalls or Idles Roughly (cold or warm).	Faulty spark plugs.
	Insufficient fuel delivery.
	TPS set incorrect.
	TPS faulty.
	Faulty engine temperature sensor.
Engine Misses, Hesitates, or Stalls Under Load.	Fuel injector(s), fuel filter, fuel line, or fuel pick-up dirty/restricted.
	Dirty air cleaner.
	Insufficient fuel pressure or fuel delivery.
	Vacuum (intake air) leak.
	Improper governor setting, adjustment or operation.
	TPS faulty, mounting problem or TPS Initialization Procedure incorrect.
Low Power	Bad coil(s), spark plug(s), or wires.
	Faulty/malfunctioning ignition system.
	Dirty air filter.
	Insufficient fuel delivery.
	Improper governor adjustment.
	Plugged/restricted exhaust.
	One injector not working.
	Basic engine problem exists.
TPS faulty or mounting exists.	
Throttle plate in throttle body not fully opening to WOT stop (if equipped).	

EFI SYSTEM-ECH WITHOUT OXYGEN SENSOR

Function Test

	WARNING
	<p>High Pressure Fluids can puncture skin and cause severe injury or death.</p> <p>Do not work on fuel system without proper training or safety equipment.</p>
<p>Fluid puncture injuries are highly toxic and hazardous. If an injury occurs, seek immediate medical attention.</p>	

Function of fuel system is to provide sufficient delivery of fuel at system operating pressure of 39 psi ± 3. If an engine starts hard, or turns over but will not start, it may indicate a problem with EFI fuel system. A quick test will verify if system is operating.

1. Disconnect and ground spark plug leads.
2. Complete all safety interlock requirements and crank engine for approximately 3 seconds.
3. Remove spark plugs and check for fuel at tips.
 - a. If there is fuel at tips of spark plugs fuel pump and injectors are operating.
 - b. If there is no fuel at tips of spark plugs, check following:
 1. Make sure fuel tank contains clean, fresh, proper fuel.
 2. Make sure that vent in fuel tank is open.
 3. Make sure fuel tank valve (if equipped) is fully opened.
 4. Make sure battery is supplying proper voltage.
 5. Check that fuses are good, and that no electrical or fuel line connections are damaged or broken.
 6. Test fuel pump module operation as described earlier under Fuel Pump.

Fault Codes

Example of Diagnostic Display

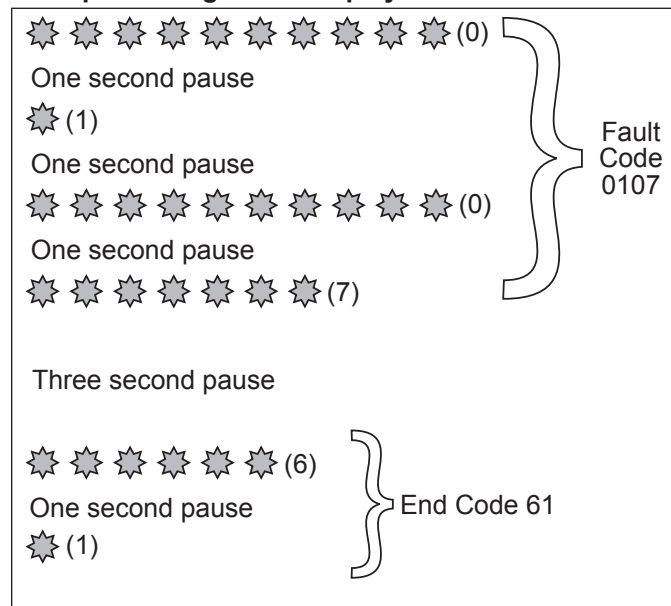

EFI SYSTEM-ECH WITHOUT OXYGEN SENSOR

Diagnostic Fault Code Summary

Fault Code	Connection or Failure Description
0107	Manifold Absolute Pressure (TMAP) Sensor Circuit Low Voltage or Open
0108	Manifold Absolute Pressure (TMAP) Sensor Circuit High Voltage
0112	Intake Air Temperature (TMAP) Sensor Circuit Low Voltage
0113	Intake Air Temperature (TMAP) Sensor Circuit High Voltage or Open
0117	Engine Temperature Sensor Circuit Low Voltage
0118	Engine Temperature Sensor Circuit High Voltage or Open
0122	Throttle Position Sensor Circuit Low Voltage or Open
0123	Throttle Position Sensor Circuit High Voltage
0201	Injector 1 Circuit Malfunction
0202	Injector 2 Circuit Malfunction
0230	Fuel Pump Module Circuit Low Voltage or Open
0232	Fuel Pump Module Circuit High Voltage
0336	Crankshaft Position Sensor Noisy Signal
0337	Crankshaft Position Sensor No Signal
0351	Cylinder 1 Ignition Coil Malfunction
0352	Cylinder 2 Ignition Coil Malfunction
0562	System Voltage Low
0563	System Voltage High
61	End of Code Transmission

ECU continuously monitors engine operation against preset performance limits. If operation is outside limits, ECU activates MIL, if equipped, and stores a diagnostic code in its fault memory. If component or system returns to proper function, ECU will turn off MIL. If MIL stays illuminated, it warns customer a fault is currently happening, and dealer service is required. Upon receipt, dealer technician can access fault code(s) to help determine what portion of system is malfunctioning.

Codes are accessed through key switch and displayed as blinks or flashes of MIL. Access codes as follows:

1. Check that battery voltage is above 11 volts.
2. Start with key switch OFF.
3. Turn key switch to ON and OFF, then ON and OFF, then ON, leaving it on in third sequence. Do not start engine. Time between sequences must be less than 2.5 seconds.
4. MIL will blink a series of times. Number of times MIL blinks represents a number in blink code.
5. A sequence of four digits make up a fault code. There is a one (1) second pause between blinks of a fault code. There is a three (3) second pause between separate fault codes. After fault code(s) are blinked a two digit 61 is blinked to indicate program has completed.

- a. It's a good idea to write down codes as they appear, as they may not be in numerical sequence.
- b. Code 61 will always be last code displayed, indicating end of code transmission. If code 61 appears immediately, no other fault codes are present.

After problem has been corrected, fault codes may be cleared by following ECU Reset and TPS Learn Procedures.

Diagnostic Fault Code Summary lists fault codes, and what they correspond to. Diagnostic Code Summary is a list of individual codes with an explanation of what triggers them, what symptoms might be expected, and probable causes.

A MIL may not be provided with engine. If equipment manufacturer has not added a MIL to equipment, one can be added easily for quick diagnostics. Main engine to vehicle connection will have a tan wire which is ground for MIL. Either incandescent or LED type bulbs can be used for MIL as long as they do not draw more than 0.1 amps. Bulb needs to be rated at 1.4 Watts or less, or needs to have a total resistance of 140 Ω or more. LEDs typically draw less than 0.03 amps. Attach +12 volts to positive terminal of bulb and attach ground terminal of bulb to tan wire.

EFI SYSTEM-ECH WITHOUT OXYGEN SENSOR

Diagnostic Code Summary

Code 0107

Component:	Manifold Absolute Pressure (TMAP) Sensor
Fault:	TMAP Circuit Low Voltage or Open
Condition:	Intake manifold leak, open connection or faulty sensor.
Conclusion:	<p>TMAP Sensor Related</p> <ul style="list-style-type: none"> ● Sensor malfunction. ● Vacuum leaks from loose manifold or sensor. <p>Wire Harness Related</p> <ul style="list-style-type: none"> ● Poor grounding or open circuit. ● Wire harness and connectors loose, damaged or corroded. ● Pin circuit wiring or connectors at Black 10, 11 and 16. <p>Bad TPS Learn.</p>

Code 0108

Component:	Manifold Absolute Pressure (TMAP) Sensor
Fault:	TMAP Circuit High Voltage
Condition:	Intake manifold leak, shorted connection or faulty sensor.
Conclusion:	<p>TMAP Sensor Related</p> <ul style="list-style-type: none"> ● Sensor malfunction. ● Vacuum leaks from loose manifold or sensor. <p>Wire Harness Related</p> <ul style="list-style-type: none"> ● Poor grounding. ● Pin circuit wiring or connectors at Black 11. <p>Bad TPS Learn.</p>

Code 0112

Component:	Intake Air Temperature (TMAP) Sensor
Fault:	Intake Air Temperature (TMAP) Sensor Circuit Low Voltage
Condition:	Shorted connection, faulty sensor or shorted wire.
Conclusion:	<p>Temperature (TMAP) Sensor Related</p> <ul style="list-style-type: none"> ● Sensor wiring or connection. <p>Engine Wiring Harness Related</p> <ul style="list-style-type: none"> ● Pin circuits Black 10 and Black 8 may be damaged or routed near noisy signal (coils, alternator, etc.). ● ECU-to-harness connection problem.

Code 0113

Component:	Intake Air Temperature (TMAP) Sensor
Fault:	Intake Air Temperature (TMAP) Sensor Circuit High Voltage or Open
Condition:	Shorted connection, faulty sensor, broken wire or connection.
Conclusion:	<p>Temperature (TMAP) Sensor Related</p> <ul style="list-style-type: none"> ● Sensor wiring or connection. <p>Engine Wiring Harness Related</p> <ul style="list-style-type: none"> ● Pin circuits ECU Black pin 10 and 8 may be damaged. ● ECU-to-harness connection problem or broken wire.

EFI SYSTEM-ECH WITHOUT OXYGEN SENSOR

Code 0117

Component:	Engine Temperature Sensor
Fault:	Engine Temperature Sensor Circuit Low Voltage
Condition:	Shorted connection, faulty sensor or shorted wire.
Conclusion:	<p>Temperature Sensor Related</p> <ul style="list-style-type: none"> • Sensor wiring or connection. <p>Engine Wiring Harness Related</p> <ul style="list-style-type: none"> • Pin circuits Black 10 and Black 14 maybe damaged or routed near noisy signal (coils, stator, etc.). • ECU-to-harness connection problem.

Code 0118

Component:	Engine Temperature Sensor
Fault:	Engine Temperature Sensor Circuit High Voltage or Open
Condition:	Shorted connection, faulty sensor, open connection or broken wire.
Conclusion:	<p>Temperature Sensor Related</p> <ul style="list-style-type: none"> • Sensor wiring or connection. <p>Engine Wiring Harness Related</p> <ul style="list-style-type: none"> • Pin circuits ECU Black pin 10 and 14 may be damaged. • ECU-to-harness connection problem or broken wire. <p>System Related</p> <ul style="list-style-type: none"> • Engine is operating above 176°C (350°F) temperature sensor limit.

Code 0122

Component:	Throttle Position Sensor (TPS)
Fault:	TPS Circuit Low Voltage or Open
Condition:	Open connection, broken wire or faulty sensor.
Conclusion:	<p>TPS Related</p> <ul style="list-style-type: none"> • TPS bad or worn internally. <p>Engine Wiring Harness Related</p> <ul style="list-style-type: none"> • Broken or shorted wire in harness. <ul style="list-style-type: none"> ECU Black pin 10 to TPS pin 1. ECU Black pin 12 to TPS pin 3. ECU Black pin 16 to TPS pin 2. <p>Throttle Body Related</p> <ul style="list-style-type: none"> • Throttle shaft inside TPS worn, broken, or damaged. • Throttle plate loose or misaligned. • Throttle plate bent or damaged allowing extra airflow past, or restricting movement. <p>ECU Related</p> <ul style="list-style-type: none"> • Circuit providing voltage or ground to TPS damaged. • TPS signal input circuit damaged.

Code 0123

Component:	Throttle Position Sensor (TPS)
Fault:	TPS Circuit High Voltage
Condition:	Shorted connection or faulty sensor.
Conclusion:	<p>TPS Sensor Related</p> <ul style="list-style-type: none"> • Sensor connector or wiring. • Sensor output affected or disrupted by dirt, grease, oil, wear. • Sensor loose on throttle body manifold. <p>Throttle Body Related</p> <ul style="list-style-type: none"> • Throttle shaft or bearings worn/damaged. <p>Engine Wiring Harness Related</p> <ul style="list-style-type: none"> • ECU pins Black 10, 12 and 16 damaged (wiring, connectors). • ECU pins Black 10, 12 and 16 routed near noisy electrical signal (coils, alternator). • Intermittent 5 volt source from ECU (pin Black 16). • ECU-to-harness connection problem.

EFI SYSTEM-ECH WITHOUT OXYGEN SENSOR

Code 0201

Component:	Fuel Injector
Fault:	Injector 1 Circuit Malfunction
Condition:	Injector damaged or faulty, shorted or open connection.
Conclusion:	<p>Injector Related</p> <ul style="list-style-type: none"> ● Injector coil shorted or opened. <p>Engine Wiring Harness Related</p> <ul style="list-style-type: none"> ● Broken or shorted wire in harness. ECU pin Black 5. ● Wiring from Ignition. <p>ECU Related</p> <ul style="list-style-type: none"> ● Circuit controlling injector #1 damaged.

Code 0202

Component:	Fuel Injector
Fault:	Injector 2 Circuit Malfunction
Condition:	Injector damaged or faulty, shorted or open connection.
Conclusion:	<p>Injector Related</p> <ul style="list-style-type: none"> ● Injector coil shorted or opened. <p>Engine Wiring Harness Related</p> <ul style="list-style-type: none"> ● Broken or shorted wire in harness. ECU pin Black 6. ● Wiring from Ignition. <p>ECU Related</p> <ul style="list-style-type: none"> ● Circuit controlling injector #2 damaged.

Code 0230

Component:	Fuel Pump
Fault:	Circuit Low Voltage or Open
Condition:	Shorted or open connection.
Conclusion:	<p>Fuel Pump Related</p> <ul style="list-style-type: none"> ● Fuel pump module open or shorted internally. <p>Engine Wiring Harness related</p> <ul style="list-style-type: none"> ● Broken or shorted wire in harness. ECU pin Black 9 or Grey 17. <p>ECU Related</p> <ul style="list-style-type: none"> ● ECU is damaged.

Code 0232

Component:	Fuel Pump
Fault:	Circuit High Voltage
Condition:	Shorted connection.
Conclusion:	<p>Fuel Pump Related</p> <ul style="list-style-type: none"> ● Fuel pump module damaged internally. <p>Charging Output System Too High.</p>

EFI SYSTEM-ECH WITHOUT OXYGEN SENSOR

Code 0336

Component:	Crankshaft Position Sensor
Fault:	Crankshaft Position Sensor Noisy Signal
Condition:	Air gap incorrect, loose sensor, faulty/bad battery, shorted or faulty connection, faulty sensor or faulty sensor grounding.
Conclusion:	<p>Crankshaft Position Sensor Related</p> <ul style="list-style-type: none"> • Sensor connector or wiring. • Sensor loose or air gap incorrect. <p>Crankshaft Position Sensor Wheel Related</p> <ul style="list-style-type: none"> • Damaged teeth. • Gap section not registering. <p>Engine Wiring Harness Related</p> <ul style="list-style-type: none"> • Pin circuit wiring or connectors. ECU pin Black 4 and Black 13. • ECU-to-harness connection problem. <p>Ignition System Related</p> <ul style="list-style-type: none"> • Non-resistor spark plug(s) used. • Faulty or disconnected ignition coil or secondary lead.

Code 0337

Component:	Crankshaft Position Sensor
Fault:	Crankshaft Position Sensor No Signal
Condition:	Air gap incorrect, loose sensor, open or shorted connection or faulty sensor.
Conclusion:	<p>Crankshaft Position Sensor Related</p> <ul style="list-style-type: none"> • Sensor connector or wiring. • Sensor loose or air gap incorrect. <p>Crankshaft Position Sensor Wheel Related</p> <ul style="list-style-type: none"> • Damaged teeth. <p>Engine Wiring Harness Related</p> <ul style="list-style-type: none"> • Pin circuit wiring or connectors. ECU pin Black 4 or Black 13. • ECU-to-harness connection problem. <p>If code is stored in fault history and starts normally. Clear code, no other service required.</p>

Code 0351

Component:	Ignition Coil
Fault:	Cylinder 1 Ignition Coil Malfunction
Condition:	Broken wire in harness (may not be visible), shorted connection or faulty sensor.
Conclusion:	<p>Engine Wiring Harness Related</p> <ul style="list-style-type: none"> • Connection to ignition or fuse. • Pin circuit wiring or connectors. • ECU pin Black 1. • ECU-to-harness connection problem. <p>Ignition System Related</p> <ul style="list-style-type: none"> • Incorrect spark plug(s) used. • Poor connection to spark plug.

Code 0352

Component:	Ignition Coil
Fault:	Cylinder 2 Ignition Coil Malfunction
Condition:	Broken wire in harness (may not be visible), shorted connection or faulty sensor.
Conclusion:	<p>Engine Wiring Harness Related</p> <ul style="list-style-type: none"> • Connection to ignition or fuse. • Pin circuit wiring or connectors. ECU pin Grey 10. • ECU-to-harness connection problem. <p>Ignition System Related</p> <ul style="list-style-type: none"> • Incorrect spark plug(s) used. • Poor connection to spark plug.

Code 0562

Component:	System Voltage
Fault:	System Voltage Low
Condition:	Faulty voltage regulator, bad fuse or shorted connection.
Conclusion:	<p>Corroded Connections</p> <p>Bad Stator</p> <p>Bad Battery</p> <ul style="list-style-type: none"> • Low output charging system. • Poor magnet in flywheel. • Bad or missing fuse.

Code 0563

Component:	System Voltage
Fault:	System Voltage High
Condition:	Faulty voltage regulator or shorted connection.
Conclusion:	<p>Faulty Rectifier-Regulator</p> <p>Bad Stator.</p> <p>Bad Battery.</p>

Code 61

Component:	End of Code Transmission
------------	--------------------------

EFI SYSTEM-ECH WITHOUT OXYGEN SENSOR

Troubleshooting Flow Chart

Following flow chart provides an alternative method of troubleshooting EFI system. Chart will enable you to review entire system in about 10-15 minutes. Using chart, accompanying diagnostic aids (listed after chart), and any signaled fault codes, you should be able to quickly locate any problems within system.

Flow Chart Diagnostic Aids

Diagnostic Aid #1 SYSTEM POWER

(MIL does not illuminate when key is turned ON)

NOTE: MIL is installed by vehicle OEM. Twelve volt supply to bulb will be part of vehicle wire harness. Rehlko key switch model will have MIL on engine with 12V supply to bulb.

Conclusion

- Battery
- Main system fuse
- MIL light bulb burned out
- MIL electrical circuit problem
 - Pin circuits Grey 3.
- Ignition switch
- Permanent ECU power circuit problem
 - Pin circuit Black 18.
- Switched ECU power circuit problem
 - Pin circuit Black 15.
- ECU grounds
- ECU

Diagnostic Aid #2 FAULT CODES

Refer to Diagnostic Fault Code Summary.

Diagnostic Aid #3 RUN/ON

(MIL remains ON while engine is running)*

Condition

NOTE: Either incandescent or LED type bulbs can be used for MIL as long as they do not draw more than 0.1 amps. Bulb needs to be rated at 1.4 Watts or less, or needs to have a total resistance of 140 Ω or more. LEDs typically draw less than 0.03 amps.

*All current fault codes will turn on MIL when engine is running.

Diagnostic Aid #4 CRANKSHAFT POSITION SENSOR

(MIL does not turn off during cranking)

Condition

- Crankshaft position sensor
- Crankshaft position sensor circuit problem, pin circuits Black 4 and Black 13.
- Crankshaft position sensor/toothed wheel air gap
- Toothed wheel
- Flywheel key sheared
- ECU

Diagnostic Aid #5 FUEL PUMP

(fuel pump not turning on)

Condition

- Main fuse
- Fuel pump circuit problem, pin circuits Black 9 and Grey 17.
- Fuel pump module

Diagnostic Aid #6 IGNITION SYSTEM

(no spark)

Condition

- Spark plug
- Plug wire
- Coil
- Coil circuit(s), pin circuits Grey 10 and Black 1.
- ECU grounds
- ECU
- Vehicle safety interlocks, ground signal on safety wire.

Diagnostic Aid #7 FUEL SYSTEM ELECTRICAL

(no fuel delivery)

Condition

- No fuel
- Air in high pressure fuel line
- Fuel valve shut OFF
- Fuel filter/line plugged
- Injector circuit(s), pin circuits Black 5 and Black 6
- Injector
- ECU grounds
- ECU
- Lift pump not working

Diagnostic Aid #8 FUEL SYSTEM

(fuel pressure)

Low Fuel Pressure-Condition

- Low fuel
- Fuel filter plugged
- Fuel supply line plugged
- Lift fuel pump - insufficient fuel supply
- Fuel pump (lift or module) - internally plugged
- Pressure regulator not functioning properly inside fuel pump module.

Diagnostic Aid #9 BASIC ENGINE

(cranks but will not run)

Condition

- Refer to basic engine troubleshooting charts within Troubleshooting.

EFI SYSTEM-ECH WITHOUT OXYGEN SENSOR

EFI Diagnostic Flow Diagram

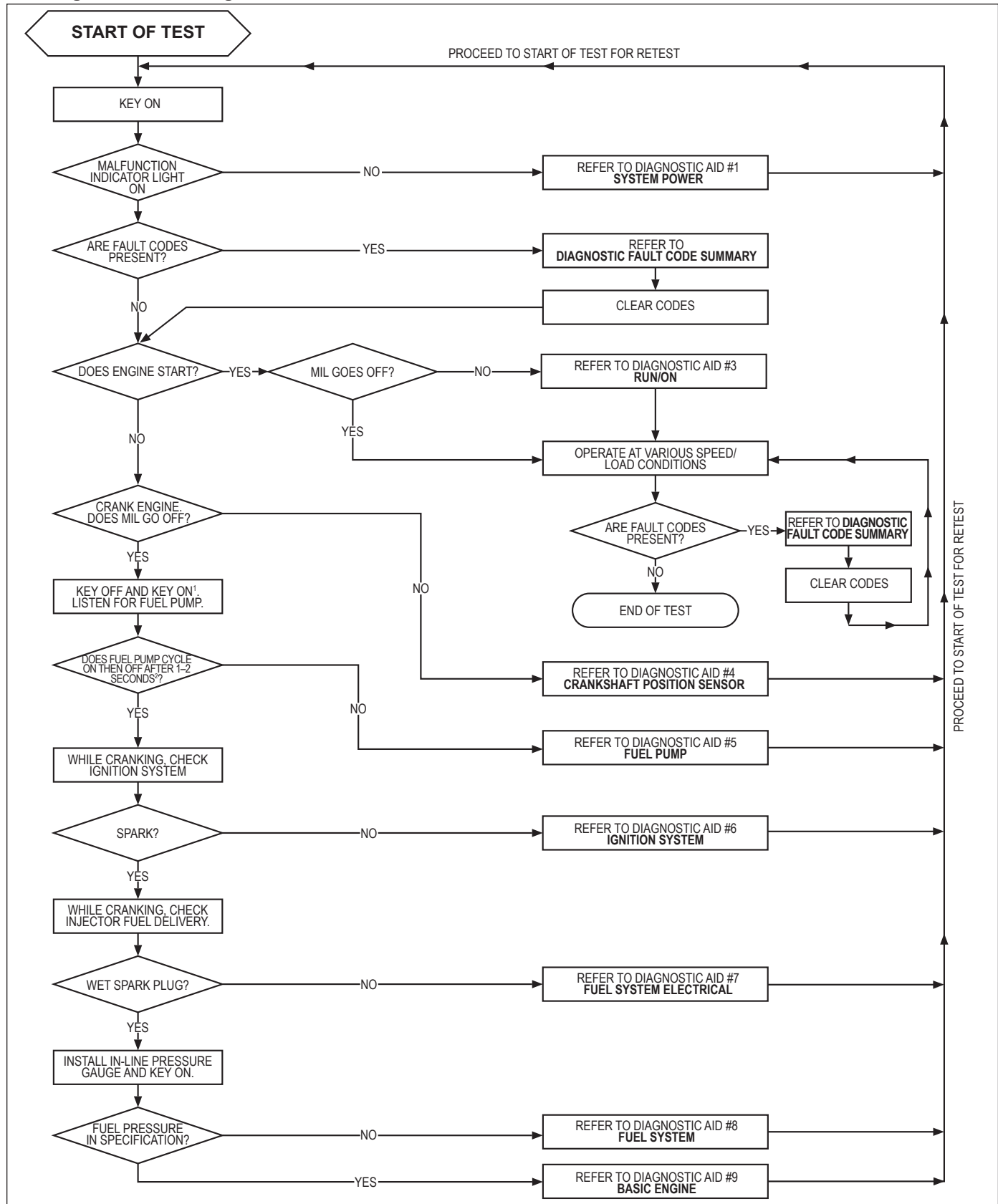

1. After turning key to OFF, wait 10 seconds before turning to ON to allow ECU to go to sleep.
2. Fuel pump module can be heard or a vibration can be felt to establish pump cycle. Fuel pump module will run for one 4-6 second cycle when ECU wakes up after being asleep.



⚠ WARNING

Explosive Fuel can cause fires and severe burns.
Do not fill fuel tank while engine is hot or running.

Gasoline is extremely flammable and its vapors can explode if ignited. Store gasoline only in approved containers, in well ventilated, unoccupied buildings, away from sparks or flames. Spilled fuel could ignite if it comes in contact with hot parts or sparks from ignition. Never use gasoline as a cleaning agent.

Bosch EFI System

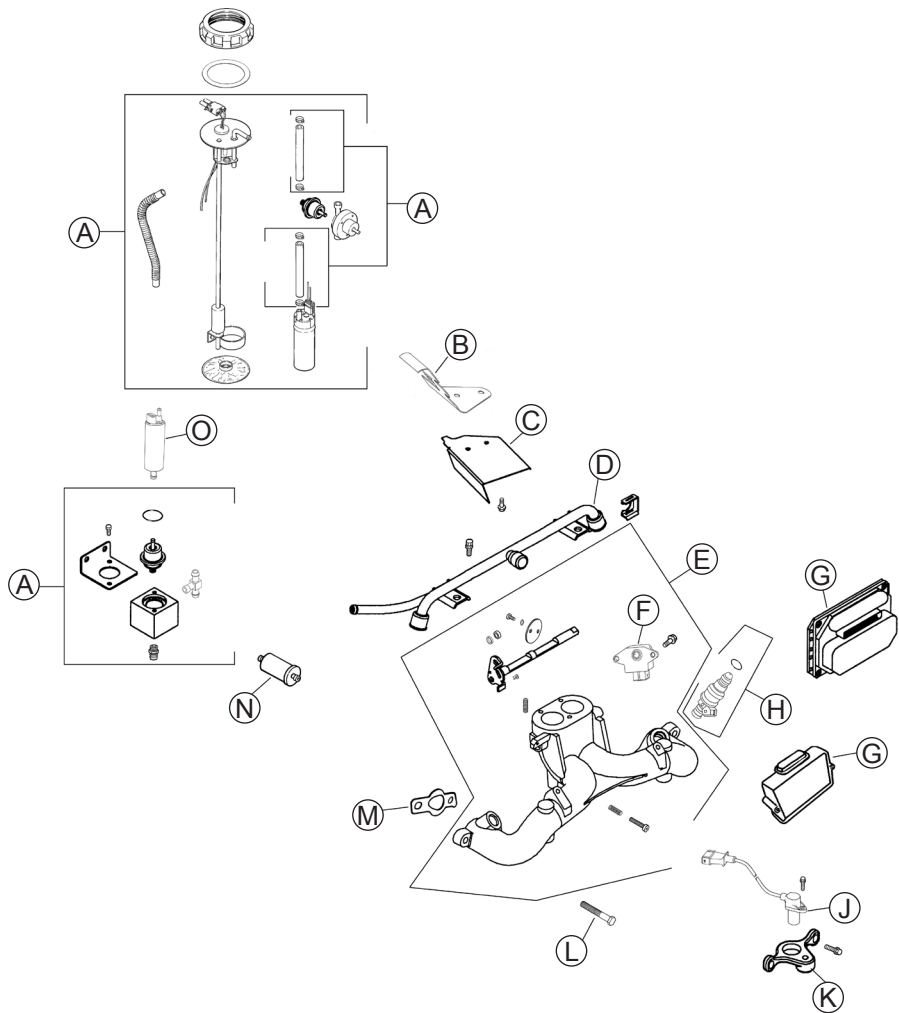

A	Fuel Pressure Regulator	B	Valley Baffle	C	Air Deflector	D	Fuel Rail
E	Intake Manifold Kit	F	Throttle Position Sensor	G	Module	H	Fuel Injector
I	ECU	J	Speed Pick-up Sensor	K	Speed Sensor Bracket	L	Screw
M	Intake Gasket	N	Fuel Filter	O	Fuel Pump Assembly		

EFI SYSTEM-BOSCH

Typical electronic fuel injection (EFI) system and related components include:

- Fuel tank and valve.
- Fuel pump.
- Fuel filter.
- Fuel rail.
- Fuel line(s).
- Fuel injectors.
- Fuel pressure regulator.
- Throttle body/intake manifold.
- Electronic control unit (ECU).
- Ignition coils.
- Engine (oil) temperature sensor.
- Throttle position sensor (TPS).
- Speed sensor.
- Crankshaft position sensor.
- Oxygen sensor.
- Wire harness assembly & affiliated wiring.
- Malfunction indicator light (MIL).
- Intake air temperature sensor.

FUEL RECOMMENDATIONS

Refer to Maintenance.

FUEL LINE

Low permeation fuel line must be installed on all Rehlko engines to maintain EPA and CARB regulatory compliance.

Operation

NOTE: When performing voltage or continuity tests, avoid putting excessive pressure on or against connector pins. Flat pin probes are recommended for testing to avoid spreading or bending terminals.

EFI system is designed to provide peak engine performance with optimum fuel efficiency and lowest possible emissions. Ignition and injection functions are electronically controlled, monitored and continually corrected during operation to maintain ideal air/fuel ratio.

Central component of system is Engine Control Unit (ECU) which manages system operation, determining best combination of fuel mixture and ignition timing for current operating conditions.

An electric fuel pump is used to move fuel from tank through fuel line and in-line fuel filter. A fuel pressure regulator maintains a system operating pressure of 39 psi and returns any excess fuel to tank. At engine, fuel is fed through fuel rail and into injectors, which inject it into intake ports. ECU controls amount of fuel by varying length of time that injectors are "ON." This can range from 1.5-8.0 milliseconds depending on fuel requirements. Controlled injection of fuel occurs each crankshaft revolution, or twice for each 4-stroke cycle. One-half total amount of fuel needed for one firing of a cylinder is injected during each injection. When intake valve opens, fuel/air mixture is drawn into combustion chamber, ignited, and burned.

ECU controls amount of fuel being injected and ignition timing by monitoring primary sensor signals for engine temperature, speed (RPM), and throttle position (load). These primary signals are compared to preprogrammed maps in ECU computer chip, and ECU adjusts fuel delivery to match mapped values. After engine reaches operating temperature, an exhaust gas oxygen sensor provides feedback to ECU based upon amount of unused oxygen in exhaust, indicating whether fuel mixture being delivered is rich or lean. Based upon this feedback, ECU further adjusts fuel input to re-establish ideal air/fuel ratio. This operating mode is referred to as closed loop operation. EFI system operates closed loop when all three of following conditions are met:

- Oil temperature is greater than 35°C (95°F).
- Oxygen sensor has warmed sufficiently to provide a signal (minimum 375°C, 709°F).
- Engine operation is at a steady state (not starting, warming up, accelerating, etc.).

During closed loop operation ECU has ability to readjust temporary and learned adaptive controls, providing compensation for changes in overall engine condition and operating environment, so it will be able to maintain ideal air/fuel ratio. This system requires a minimum engine oil temperature greater than 80°C (176°F) to properly adapt. These adaptive values are maintained as long as ECU is not reset.

During certain operating periods such as cold starts, warm up, acceleration, etc., an air/fuel ratio richer than 14.7:1 is required and system operates in an "open loop" mode. In "open loop" operation oxygen sensor output is not used, and controlling adjustments are based on primary sensor signals and programmed maps only. System operates "open loop" whenever three conditions for closed loop operation (above) are not being met.

ECU is a brain or central processing computer of entire EFI fuel/ignition management system. During operation, sensors continuously gather data which is relayed through wiring harness to input circuits within ECU. Signals to ECU include: ignition (on/off), crankshaft position and speed (RPM), throttle position, oil temperature, exhaust oxygen levels, and battery voltage. ECU compares input signals to programmed maps in its memory to determine appropriate fuel and spark requirements for immediate operating conditions. ECU then sends output signals to set injector duration and ignition timing.

ECU compares input signals to programmed maps in its memory to determine appropriate fuel and spark requirements for immediate operating conditions. ECU then sends output signals to set injector duration and ignition timing.

ECU continually performs a diagnostic check of itself, each of sensors, and system performance. If a fault is detected, ECU can turn on a Malfunction Indicator Light (MIL) (if equipped) on equipment control panel, store fault code in its fault memory, and go into a default operating mode. Depending on significance or severity of fault, normal operation may continue. A technician can access stored fault code using a blink code diagnosis flashed out through MIL. An optional computer software diagnostic program is also available, refer to Tools and Aids.

ECU requires a minimum of 7.0 volts to operate. Adaptive memory in ECU is operational whenever required voltage is present, however adapted values are lost if power supply is disrupted for any reason. ECU will “relearn” adapted values if engine is operated for 10-15 minutes at varying speeds and loads after oil temperature exceeds 55°C (130°F).

To prevent engine over-speed and possible failure, a “rev-limiting” feature is programmed into ECU. If maximum RPM limit (4500) is exceeded, ECU suppresses injection signals, cutting off fuel flow. This process repeats itself in rapid succession, limiting operation to preset maximum.

Engine speed sensor is essential to engine operation; constantly monitoring rotational speed (RPM) of crankshaft. A ferromagnetic 60-tooth ring gear with two consecutive teeth missing is mounted on flywheel. Inductive speed sensor is mounted **1.5 ± 0.25 mm (0.059 ± 0.010 in.)** away from ring gear. During rotation, an AC voltage pulse is created within sensor for each passing tooth. ECU calculates engine speed from time interval between consecutive pulses. Two-tooth gap creates an interrupted input signal, corresponding to specific crankshaft position (84° BTDC) for cylinder #1. This signal serves as a reference for control of ignition timing by ECU. Synchronization of inductive speed pickup and crankshaft position takes place during first two revolutions each time engine is started. Sensor must be properly connected at all times. If sensor becomes disconnected for any reason, engine will quit running.

Throttle position sensor (TPS) is used to indicate throttle plate angle to ECU. Since throttle (by way of governor) reacts to engine load, angle of throttle plate is directly related to load on engine.

Mounted on throttle body/intake manifold and operated directly off end of throttle shaft, TPS works as a potentiometer, varying voltage signal to ECU in direct correlation to angle of throttle plate. This signal, along with other sensor signals, is processed by ECU and compared to internal pre-programmed maps to determine required fuel and ignition settings for amount of load.

Correct position of TPS is established and set at factory. Do not loosen TPS or alter mounting position unless absolutely required by fault code diagnosis or throttle shaft service. If TPS is loosened or repositioned, appropriate “TPS Initialization Procedure **must** be performed to reestablish baseline relationship between ECU and TPS.

Engine (oil) temperature sensor is used by system to help determine fuel requirements for starting (a cold engine needs more fuel than one at or near operating temperature).

Mounted in oil filter adapter housing, it has a temperature-sensitive resistor that extends into oil flow. Resistance changes with oil temperature, altering voltage sent to ECU. Using a table stored in its memory, ECU correlates voltage drop to a specific temperature. Using fuel delivery “maps”, ECU then knows how much fuel is required for starting at that temperature.

Oxygen sensor functions like a small battery, generating a voltage signal to ECU based upon difference in oxygen content between exhaust gas and ambient air.

Tip of sensor, protruding into exhaust gas, is hollow. Outer portion of tip is surrounded by exhaust gas, with inner portion exposed to ambient air. When oxygen concentration on one side of tip is different than that of other side, a voltage signal between 0.2 and 1.0 volts is generated between electrodes and sent to ECU. Voltage signal tells ECU if engine is straying from ideal 14.7:1 fuel mixture, and ECU then adjusts injector pulse accordingly.

Oxygen sensor can function only after being heated by exhaust temperatures to a minimum of 375°C (709°F). A cold oxygen sensor will require approximately 1-2 minutes at moderate engine load to warm sufficiently to generate a voltage signal. Proper grounding is also critical. Oxygen sensor grounds through metal shell, so a good, solid, unbroken ground path back through exhaust system components, engine, and wiring harness is required. Any disruption or break in ground circuit can affect output signal and trigger misleading fault codes. Keep that in mind when doing any troubleshooting associated with oxygen sensor. Oxygen sensor can also be contaminated by leaded fuel, certain RTV and/or other silicone compounds, carburetor cleaners, etc. Use only those products indicated as “O₂ Sensor Safe.”

Electrical relay is used to supply power to injectors, coil, and fuel pump. When key switch is turned “ON” and all safety switch requirements met, relay provides 12 volts to fuel pump circuit, injectors, and ignition coils. Fuel pump circuit is continuously grounded, so pump is immediately activated and pressurizes system. Activation of ignition coils and fuel injectors is controlled by ECU, which grounds their respective ground circuits at proper times.

Fuel injectors mount into throttle body/intake manifold, and fuel rail attaches to them at top end. Replaceable O-Rings on both ends of injector prevent external fuel leakage and also insulate it from heat and vibration. A special clip connects each injector to fuel rail and holds it in place. O-Rings must be replaced anytime injector is removed.

When key switch is on and relay is closed, fuel rail is pressurized, and voltage is present at injector. At proper instant, ECU completes ground circuit, energizing injector. Valve needle in injector is opened electromagnetically, and pressure in fuel rail forces fuel down through inside. “Director plate” at tip of injector contains a series of calibrated openings which directs fuel into manifold in a cone-shaped spray pattern.

Injector is opened and closed once for each crankshaft revolution, however only one-half total amount of fuel needed for one firing is injected during each opening. Amount of fuel injected is controlled by ECU and determined by length of time valve needle is held open, also referred to as “injection duration” or “pulse width”. It may vary in length from 1.5-8 milliseconds depending on speed and load requirements of engine.

EFI SYSTEM-BOSCH

A high-voltage, solid-state, battery ignition system is used with EFI system. ECU controls ignition output and timing through transistorized control of primary current delivered to coils. Based on input from speed sensor, ECU determines correct firing point for speed at which engine is running. At proper instant, it releases flow of primary current to coil. Primary current induces high voltage in coil secondary, which is then delivered to spark plug. Each coil fires every revolution, but every other spark is "wasted".

An electric fuel pump is used to transfer fuel in EFI system. Depending on application, pump may be inside fuel tank, or in fuel line near tank. Pumps are rated for a minimum output of 25 liters per hour at 39 psi. Pumps have an internal 60-micron filter. In addition, in-tank style pumps will have a pre-filter attached to inlet. In-line pump systems may also have a filter between tank and pump on pickup/low pressure side.

When key switch is turned "ON" and all safety switch requirements are met, ECU, through relay activates fuel pump, which pressurizes system for start-up. If key switch is not promptly turned to start position, engine fails to start, or engine is stopped with key switch "on" (as in case of an accident), ECU switches off pump preventing continued delivery of fuel. In this situation, MIL will go on, but it will go back off after 4 cranking revolutions if system function is OK. Once engine is running, fuel pump remains on.

Fuel pressure regulator assembly maintains required operating system pressure of **39 psi ± 3**. A rubber-fiber diaphragm divides regulator into two separate sections; fuel chamber and pressure regulating chamber. Pressure regulating spring presses against valve holder (part of diaphragm), pressing valve against valve seat. Combination of atmospheric pressure and regulating spring tension equals desired operating pressure. Any time fuel pressure against bottom of diaphragm exceeds desired (top) pressure, valve opens, relieving excess pressure, returning excess fuel back to tank.

Fuel rail is a formed tube assembly that feeds fuel to top of injectors. Tops of injectors fit into formed cups in fuel rail. When rail is fastened to manifold, injectors are locked into place. A small retaining clip provides a secondary lock. Incorporated into fuel rail is a pressure relief/test valve for testing operating pressure or relieving fuel system pressure for servicing. Fuel supply line is attached to barbed end of fuel rail with an Oetiker hose clamp.

EFI engines have no carburetor, so throttle function (regulate incoming combustion airflow) is incorporated in intake manifold assembly. Manifold consists of a one-piece aluminum casting which also provides mounting for fuel injectors, throttle position sensor, fuel rail, air baffle, idle speed screw, and air cleaner assembly.

Idle speed is only adjustment that may be performed on EFI system. Standard idle speed setting for EFI engines is **1500 RPM**, but certain applications might require a different setting. Check equipment manufacturer's recommendation.

For starting and warm up, ECU will adjust fuel and ignition timing, based upon ambient temperature, engine temperature, and loads present. In cold conditions, idle speed will probably be higher than normal for a few moments. Under other conditions, idle speed may actually start lower than normal, but gradually increase to established setting as operation continues. Do not attempt to circumvent this warm up period, or readjust idle speed during this time. Engine must be completely warmed up, in closed loop operating mode for accurate idle adjustment.

IMPORTANT NOTES!

- Cleanliness is essential and must be maintained at all times when servicing or working on EFI system. Dirt, even in small quantities, can cause significant problems.
- Clean any joint or fitting with parts cleaning solvent before opening to prevent dirt from entering system.
- Always depressurize fuel system through fuel connector on fuel pump module before disconnecting or servicing any fuel system components.
- Never attempt to service any fuel system component while engine is running or ignition switch is ON.
- Do not use compressed air if system is open. Cover any parts removed and wrap any open joints with plastic if they will remain open for any length of time. New parts should be removed from their protective packaging just prior to installation.
- Avoid direct water or spray contact with system components.
- Do not disconnect or reconnect ECU wiring harness connector or any individual components with ignition on. This can send a damaging voltage spike through ECU.
- Do not allow battery cables to touch opposing terminals. When connecting battery cables attach positive (+) cable to positive (+) battery terminal first, followed by negative (-) cable to negative (-) battery terminal.
- Never start engine when cables are loose or poorly connected to battery terminals.
- Never disconnect battery while engine is running.
- Never use a quick battery charger to start engine.
- Do not charge battery with key switch ON.
- Always disconnect negative (-) battery cable before charging battery, and also unplug harness from ECU before performing any welding on equipment.

Initial Starting/Priming Procedure

Important: EFI fuel system must be purged of air (primed) prior to initial start up, and/or any time system has been disassembled or fuel tank run dry.

1. Locate electronic control unit (ECU) for EFI system. Check part number on end. If Part No. is 24 584 28 or higher, ECU has a built-in priming feature.
 - a. Turn key switch to "ON/RUN" position. You will hear fuel pump cycle on and off. When fuel pump stops cycling (approximately one minute), system is primed; start engine.

2. For plastic-cased ECU's below 24 584 28-S, system can be primed by manually cycling fuel pump.
 - a. Turn key switch to "ON/RUN" position. Fuel pump will run for about three seconds and stop. Turn switch off and back on to restart fuel pump. Repeat this procedure until fuel pump has cycled five times, then start engine.
3. System can also be primed similar to relieving pressure.
 - a. Connect pressure gauge as described above for relieving fuel pressure. Depress and hold release button and crank engine until air is purged and fuel is visible in discharge tube. If fuel is not visible after 10 seconds, stop cranking and allow starter to cool for 60 seconds.

Priming Without a Test Valve in Fuel Rail

NOTE: Number of cranking intervals necessary will depend on individual system design, and/or when system has been disassembled.

1. Crank engine in 10-15 second intervals, allowing a 60 second cool-down period between cranking intervals, until engine starts.

ELECTRICAL COMPONENTS

Three different styles of ECU's have been utilized in EFI production. First style is easily identified by its metal case with large 35 pin connector block, and also as **MA 1.7**. Second and third styles have plastic cases, but are smaller in overall size. These have either a 24 pin or 32 pin connector block and identified as **MSE 1.0** or **MSE 1.1** respectively. Basic function and operating control remains same between three, however, due to differences in internal circuitry as well as wiring harness, none of ECU's are interchangeable. Certain individual service/troubleshooting procedures also apply, where applicable, they are covered individually as: "35 Pin" (MA 1.7) Metal-Cased ECU, "24 Pin" (MSE 1.0) Plastic-Cased ECU, or "32 Pin" (MSE 1.1) Plastic-Cased ECU.

Never attempt to disassemble ECU. It is sealed to prevent damage to internal components. Warranty is void if case is opened or tampered with in any way.

All operating and control functions within ECU are preset. No internal servicing or readjustment may be performed. If a problem is encountered, and you determine ECU to be faulty, contact your source of supply. Do not replace ECU without factory authorization.

Relationship between ECU and throttle position sensor (TPS) is very critical to proper system operation. If TPS or ECU is changed, or mounting position of TPS is altered, applicable "TPS Initialization Procedure" must be performed to restore synchronization.

Engine speed sensor is a sealed, non-serviceable assembly. If "Fault Code" diagnosis indicates a problem within this area, check and test as follows.

1. Check mounting and air gap of sensor. It must be **1.5 mm ± 0.25 mm (0.059 ± 0.010 in.)**.
2. Inspect wiring and connections for damage or problems.

3. Make sure engine has resistor type spark plugs.
4. Disconnect main harness connector from ECU.
5. Connect an ohmmeter between designated pin terminals in plug:
 - "35 Pin" (MA 1.7) Metal-Cased ECU: #3 and #21 pin terminals.
 - "24 Pin" (MSE 1.0) Plastic-Cased ECU: #9 and #10 pin terminals.
 - "32 Pin" (MSE 1.1) Plastic-Cased ECU: #9 and #10 pin terminals.

See pages 130-135 according to ECU style. A resistance value of **750-1000 Ω** at room temperature (20°C, 68°F) should be obtained. If resistance is correct, check mounting, air gap, toothed ring gear (damage, runout, etc.), and flywheel key.

6. Disconnect speed sensor connector from wiring harness. It is connector with one heavy black lead. Viewing connector as shown (dual aligning rails on top), test resistance between terminals indicated. A reading of **750-1000 Ω** should again be obtained.
7. If resistance is incorrect, remove screw securing sensor to mounting bracket and replace sensor.
 - a. If resistance in step 5 was incorrect, but resistance of sensor alone was correct, test main harness circuits between sensor connector terminals and corresponding pin terminals in main connector. Correct any observed problem, reconnect sensor, and perform step 5 again.

Speed Sensor Circuit

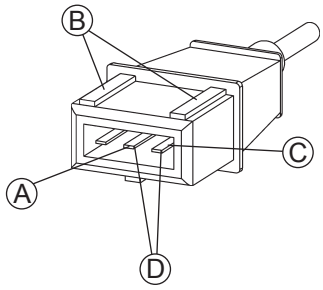

A	Corresponds To #3 (Metal-Cased ECU) or #10 (Plastic-Cased ECU) In Main Connector.	B	Dual Aligning Rails
C	Corresponds To #21 (Metal-Cased ECU) or #9 (Plastic-Cased ECU) In Main Connector.	D	Test Terminals

EFI SYSTEM-BOSCH

Throttle Position Sensor (TPS)

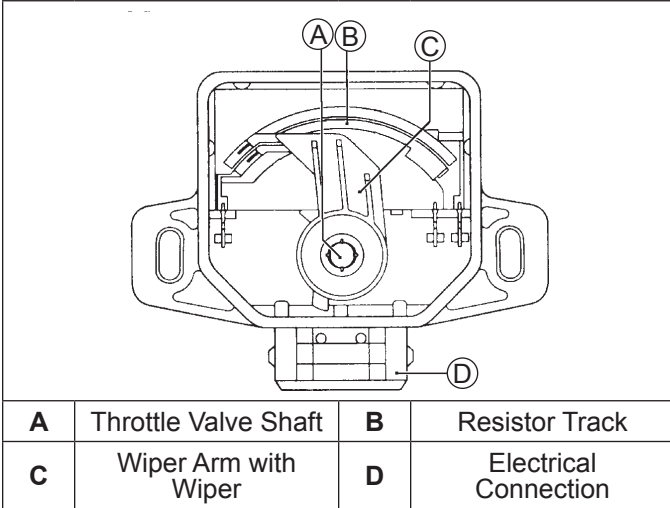

The TPS is a sealed, non-serviceable assembly. If diagnosis indicates a bad sensor, complete replacement is necessary. If a blink code indicates a problem with TPS, it can be tested as follows:

- Counting number of turns, back out idle speed adjusting screw (counterclockwise) until throttle plates can be closed completely.
- Disconnect main harness connector from ECU, but leave TPS mounted to throttle body/manifold.
- Connect ohmmeter leads as follows:

(See chart on pages).

“35 Pin” (MA 1.7) Metal-Cased ECU: Red (positive) ohmmeter lead to #12 pin terminal, and Black (negative) ohmmeter lead to #27 pin terminal.

“24 Pin” (MSE 1.0) Plastic-Cased ECU: Red (positive) ohmmeter lead to #8 pin terminal, and Black (negative) ohmmeter lead to #4 pin terminal.

“32 Pin” (MSE 1.1) Plastic-Cased ECU: Red (positive) ohmmeter lead to #8 pin terminal, and Black (negative) ohmmeter lead to #4 pin terminal.

Hold throttle closed and check resistance. It should be 800-1200 Ω .

- Leave leads connected to pin terminals as described in step 3. Rotate throttle shaft slowly counterclockwise to full throttle position. Monitor dial during rotation for indication of any momentary short or open circuits. Note resistance at full throttle position. It should be 1800-3000 Ω .
- Disconnect main wiring harness connector from TPS, leaving TPS assembled to manifold. Refer to chart below and perform resistance checks indicated between terminals in TPS switch, with throttle in positions specified.

Throttle Position	Between Terminals	Resistance Value (Ω)	Continuity
Closed	2 & 3	800-1200	Yes
Closed	1 & 3	1800-3000	Yes
Full	2 & 3	1800-3000	Yes
Full	1 & 3	800-1200	Yes
Any	1 & 2	1600-2500	Yes

If resistance values in steps 3, 4, and 5 are within specifications, go to step 6.

If resistance values are not within specifications, or a momentary short or open circuit was detected during rotation (step 4), TPS needs to be replaced, go to step 7.

- Check TPS circuits (input, ground) between TPS plug and main harness connector for continuity, damage, etc. See chart on pages

“35 Pin” (MA 1.7) Metal-Cased ECU: Pin Circuits #12 and #27.

“24 Pin” (MSE 1.0) Plastic-Cased ECU: Pin Circuits #8 and #4.

“32 Pin” (MSE 1.1) Plastic-Cased ECU: Pin Circuits #8 and #4.

- Repair or replace as required.
 - Turn idle speed screw back in to its original setting.
 - Reconnect connector plugs, start engine and retest system operation.
- Remove two mounting screws from TPS. Save screws for reuse. Remove and discard faulty TPS. Install replacement TPS and secure with original mounting screws.
 - Reconnect both connector plugs.
 - Perform appropriate “TPS Initialization Procedure” integrating new sensor to ECU.

TPS Initialization Procedure

For “35 Pin” (MA 1.7) Metal-Cased ECU and “24 Pin” (MSE 1.0) Plastic-Cased ECU only

- Check that basic engine, all sensors, fuel, fuel pressure, and battery are good and functionally within specifications.

Important!

- Remove/disconnect ALL external loads from engine (belts, pumps, electric PTO clutch, alternator, rectifier-regulator, etc.).
- Start engine and allow it to warm up for 5-10 minutes, so oil temperature is above 55°C (130°F).
- Move throttle control to idle position and allow engine to stabilize for a minimum of one minute.
- Install a heavy rubber band around throttle lever and manifold boss, to firmly hold throttle against idle stop. On some EFI engines there is a dampening spring on end of idle speed screw. Dampening spring (if used) should be fully compressed and tab on throttle lever in direct contact with speed screw. Adjust idle speed to 1500 RPM, using a tachometer.
- Shut off engine.

7. Locate service connector plug in wiring harness.
 - “**35 Pin**” (MA 1.7) Metal-Cased ECU: Connect a jumper wire from TPS initialization pin #8 (gray wire) to ground pin (black wire), or use jumper plug with red jumper wire.
 - “**24 Pin**” (MSE 1.0) Plastic-Cased ECU: Connect a jumper wire from TPS initialization pin #24 (violet wire) to battery voltage pin (red wire), or use jumper plug with blue jumper wire.
 8. Hold throttle against idle speed stop screw, turn ignition switch to “ON” position (do not start engine), and observe Malfunction Indicator Light (MIL).
 - a. Light should blink on/off quickly for approximately 3 seconds and then go off and stay off, indicating initialization procedure has been successful.
 - b. If light stays on or blinking ceases prematurely, procedure was unsuccessful and must be repeated. Possible causes for unsuccessful learning may be: 1) Movement occurred in either TPS or throttle shaft during procedure, 2) Crankshaft movement/rotation was detected by speed sensor during procedure, 3) Throttle plate position was out of learnable range (recheck 1500 RPM idle speed adjustment), or 4) Problem with ECU or TPS.
 9. When initialization procedure has been successfully completed, turn off key switch, remove jumper wire or connector, and remove rubber band from throttle lever.
 10. Disconnect negative (-) battery cable temporarily to clear all learned adjustments.
 11. Reconnect battery cable and all external loads. Readjust idle speed to equipment manufacturer’s specified setting and recheck high-speed, no-load RPM setting. Observe overall performance.
6. Run engine at full throttle (above 3000 RPM), to warm up engine and initiate O₂ sensor function in “closed-loop” operation.
 7. Watch MIL. When light starts blinking rapidly, (5 blinks per second), move throttle lever to low idle speed position. Check and adjust idle speed to 1500 RPM, using a tachometer. Lamp should continue to blink rapidly for another 30 seconds before switching to a slow blink.
 8. When MIL blinks slowly, do not do anything but wait until MIL shuts off. This indicates that this procedure has been completed successfully.
 9. Shut off engine.
 - If learn procedure was successfully completed, external loads removed/disconnected in Step 2 may be reconnected.
 - If procedure was unsuccessful see Steps a. and b. following.
 - a. If during this procedure, MIL goes back into blinking 4 consecutive blinks every 2 seconds, engine and O₂ sensor have cooled down and out of “closed-loop” operation, prohibiting learning from occurring. Repeat Steps 6-9.
 - b. If during procedure with engine running, MIL stays ON continuously, for more than 15 seconds, turn off ignition. Then initiate fault code sequence, by doing three consecutive key-on/key-off cycles leaving key “ON” in last sequence, (each key-on/key-off sequence must be less than 2.5 seconds long). Fault detected must be corrected before auto-learn function can be re-initiated. PC-based diagnostic tool and software may be used to read out fault code and assist with troubleshooting and repair.

Temperature sensor is a sealed, non-serviceable assembly. A faulty sensor must be replaced. If a blink code indicates a problem with temperature sensor, it can be tested as follows:

1. Remove oil temperature sensor from adapter housing and cap or block adapter hole.
2. Wipe sensor clean and allow it to reach room temperature (20°C, 68°F).
3. Unplug main harness connector from ECU.
4. With sensor connected, check oil temperature sensor circuit resistance. Value should be **2375-2625 Ω**. See chart on pages

“**35 Pin**” (MA 1.7) Metal-Cased ECU: Check between #14 and #27 pin terminals.

“**24 Pin**” (MSE 1.0) Plastic-Cased ECU: Check between #6 and #4 pin terminals.

“**32 Pin**” (MSE 1.1) Plastic-Cased ECU: Check between #6 and #4 pin terminals.

TPS Initialization Procedure

For “**32 Pin**” (MSE 1.1) Plastic-Cased ECU Only (“Auto-Learn” Initialization)

1. Check that basic engine, all sensors, fuel, fuel pressure, and battery are good and functionally within specifications.

Important!

2. Remove/disconnect ALL external loads from engine (belts, pumps, electric PTO clutch, alternator, rectifier-regulator, etc.).
3. Locate service connector plug in wiring harness. To initiate TPS auto-learn function, connect a jumper wire from TPS initialization pin #24 (violet wire) to battery voltage pin (red wire), or use jumper plug with blue jumper wire. If using PC-based diagnostic tool and software, refer to TPS Initialize/Special Tests-TPS Auto-learn procedure and follow prompts to complete.
4. Start engine and immediately observe Malfunction Indicator Light (MIL). Light should start blinking 4 consecutive times every 2 seconds.
5. Remove jumper wire or plug from service connector plug in wiring harness.

EFI SYSTEM-BOSCH

5. Unplug sensor connector and check sensor resistance separately. Resistance value should again be **2375-2625 Ω**.
 - a. If resistance is out of specifications, replace temperature sensor.
 - b. If it is within specifications, proceed to Step 6.
6. Check temperature sensor circuits (input, ground) from main harness connector to corresponding terminal in sensor plug for continuity, damage, etc.
 - “**35 Pin**” (MA 1.7) Metal-Cased ECU: Pin circuits #14 and #27.
 - “**24 Pin**” (MSE 1.0) Plastic-Cased ECU: Pin circuits #6 and #4.
 - “**32 Pin**” (MSE 1.1) Plastic-Cased ECU: Pin circuits #6 and #4.

Cutaway of Oxygen Sensor

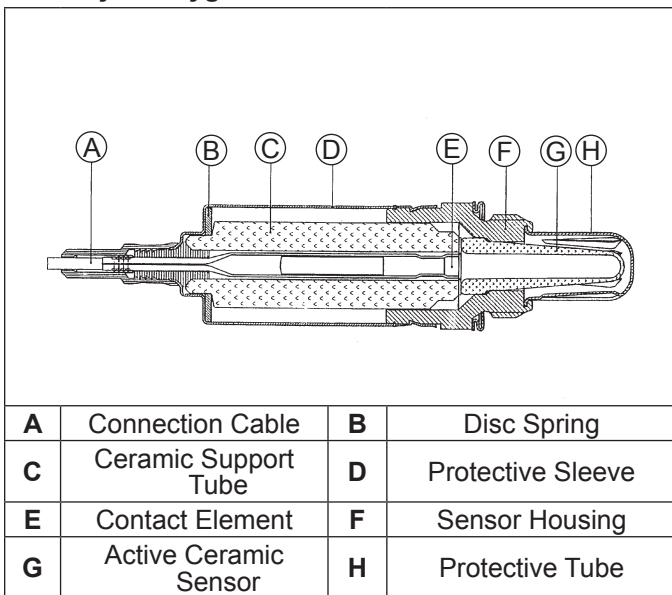

NOTE: All tests should be conducted with a good quality, high-impedance, digital VOA meter for accurate results.

Like other sensors already discussed, oxygen sensor is a non-serviceable component. Complete replacement is required if it is faulty. Sensor and wiring harness can be checked as follows.

1. Oxygen sensor must be hot (minimum of 400°C, 752°F). Run engine for about 5 minutes. With engine running, disconnect oxygen sensor lead from wiring harness. Set VOA meter for DC volts and connect red lead to disconnected sensor lead, and black lead to sensor shell. Look for a voltage reading from 0.2 v-1.0 v.
 - a. If voltage is in specified range, go to Step 2.
2. Move black voltmeter lead to engine ground location and repeat output test. Same voltage (0.2 v-1.0 v) should be indicated.
 - a. If same voltage reading exists, go on to Step 3.
 - b. If voltage output is no longer correct, a bad ground path exists between sensor and engine ground. Touch black lead at various points, backtracking from engine ground back toward sensor, watching for a voltage change at each location. If correct voltage reading reappears at some point, check for a problem (rust, corrosion, loose joint or connection) between that point and previous checkpoint. For example, if reading is too low at points on crankcase, but correct voltage is indicated when black lead is touched to skin of muffler, flange joints at exhaust ports become suspect.
3. With sensor still hot (minimum of 400°C, 752°F), switch meter to Rx1K or Rx2K scale and check resistance between sensor lead and sensor case. It should be less than 2.0 KΩ.
 - a. Resistance is less than 2.0 KΩ go to Step 4.
 - b. If resistance is greater than 2.0 KΩ, oxygen sensor is bad, replace it.
4. Allow sensor to cool (less than 60°C, 140°F) and retest resistance with meter set on Rx1M scale. With sensor cool, resistance should be greater than 1.0 MΩ.
 - a. If resistance is greater than 1.0 MΩ go to Step 5.
 - b. If resistance is less than 1.0 MΩ, sensor is bad, replace it.

- b. If voltage is not in specified range, reconnect oxygen sensor lead. With lead connected, probe or connect sensor connection with red VOA meter lead. Attach black VOA meter lead to a good ground location. Start and run engine at 3/4 throttle and note voltage reading being signaled by oxygen sensor. Reading should cycle between 0.2 v and 1.0 v, which indicates oxygen sensor is functioning normally and fuel delivery is within prescribed parameters. If voltage readings show a steady decline, rev engine and check indicated reading again. If voltage momentarily increases and then again declines, without cycling, engine may be running lean due to incorrect TPS initialization. Shut off engine, perform TPS initialization, and then repeat test. If TPS initialization cannot be achieved, perform step c.
- c. Replace oxygen sensor (see next page). Run engine long enough to bring new sensor up to temperature and repeat output test from step 1. Cycling voltage from 0.2 to 1.0 v should be indicated.

2. Move black voltmeter lead to engine ground location and repeat output test. Same voltage (0.2 v-1.0 v) should be indicated.
 - a. If same voltage reading exists, go on to Step 3.
 - b. If voltage output is no longer correct, a bad ground path exists between sensor and engine ground. Touch black lead at various points, backtracking from engine ground back toward sensor, watching for a voltage change at each location. If correct voltage reading reappears at some point, check for a problem (rust, corrosion, loose joint or connection) between that point and previous checkpoint. For example, if reading is too low at points on crankcase, but correct voltage is indicated when black lead is touched to skin of muffler, flange joints at exhaust ports become suspect.
3. With sensor still hot (minimum of 400°C, 752°F), switch meter to Rx1K or Rx2K scale and check resistance between sensor lead and sensor case. It should be less than 2.0 KΩ.
 - a. Resistance is less than 2.0 KΩ go to Step 4.
 - b. If resistance is greater than 2.0 KΩ, oxygen sensor is bad, replace it.
4. Allow sensor to cool (less than 60°C, 140°F) and retest resistance with meter set on Rx1M scale. With sensor cool, resistance should be greater than 1.0 MΩ.
 - a. If resistance is greater than 1.0 MΩ go to Step 5.
 - b. If resistance is less than 1.0 MΩ, sensor is bad, replace it.

5. With oxygen sensor disconnected and engine not running, disconnect main harness connector from ECU and set meter to Rx1 scale. Check circuit continuity as follows.
 - “24 Pin” (MSE 1.0) Plastic-Cased ECU:**
Check for continuity from pin #15 of ECU connector (see page) to shell of oxygen sensor, and from pin #11 to sensor connector terminal of main harness. Both tests should indicate continuity.

“32 Pin” (MSE 1.1) Plastic-Cased ECU:
Check for continuity from pin #19 of ECU connector (see page) to shell of oxygen sensor, and from pin #20 to sensor terminal of main harness. Both tests should indicate continuity.
 - a. If there is no continuity displayed in either of tests, check harness circuit for breaks or damage, and connections for poor contact, moisture, or corrosion. If no continuity was found in first test, also check for a poor/broken ground path back through exhaust system, engine, and mounting (sensor is grounded through its shell).
 - b. If continuity is indicated, go to step 6.
 6. With key switch in ON/RUN position, using a high impedance voltmeter, check voltage from wiring harness oxygen sensor connector to engine ground location. Look for a steady voltage from 350-550 mv (0.35-0.55 v).
 - a. If voltage reading is not as specified, move black voltmeter lead to negative post of battery, to be certain of a good ground. If voltage is still not correct, ECU is probably bad.
 - b. If voltage readings are correct, clear fault codes and run engine to check if any fault codes reappear.
- a. Clean connection and check wiring if circuit was not completed.
 3. Set meter for DC voltage. Touch red tester lead to #30 terminal in relay connector. A reading of 12 volts should be indicated at all times.
 4. Connect red lead of meter to #85 terminal in relay connector. Turn key switch to ON position. Battery voltage should be present.
 - a. No voltage present indicates a problem with key switch, in wiring, or at connector.
 - b. If voltage is present, wiring to connector is good. Turn ignition switch 'OFF and proceed to Step 5 to test relay.
 5. Connect an ohmmeter (Rx1 scale) between #85 and #86 terminals in relay. There should be continuity.
 6. Attach ohmmeter leads to #30 and #87 terminals in relay. First, there should be no continuity. Using a 12 volt power supply, connect positive (+) lead to #85 terminal and touch negative (-) lead to #86 terminal. When 12 volts is applied, relay should activate and continuity should exist between #30 and #87 terminals. Repeat test several times. If, at any time relay fails to activate circuit, replace relay.

To Replace Oxygen Sensor

1. Disconnect oxygen sensor connector from wiring harness.
2. Loosen and remove oxygen sensor from exhaust manifold/muffler assembly.
3. Apply anti-seize compound sparingly to threads of new oxygen sensor, if none already exists. DO NOT get any on tip as it will contaminate sensor. Install sensor and torque to 50-60 N·m (37-44 ft. lb.).
4. Reconnect lead to wiring harness connector. Make sure it can not contact hot surfaces, moving parts, etc.
5. Test run engine.

A malfunctioning relay can result in starting or operating difficulties. Relay and related wiring can be tested as follows:

1. Disconnect relay connector plug from relay.
2. Connect black lead of VOA meter to a chassis ground location. Connect red lead to #86 terminal in relay connector. Set meter to test resistance (Rx1). Turn ignition switch from OFF to ON. Meter should indicate continuity (ground circuit is completed) for 1 to 3 seconds. Turn key switch back off.

EFI SYSTEM-BOSCH

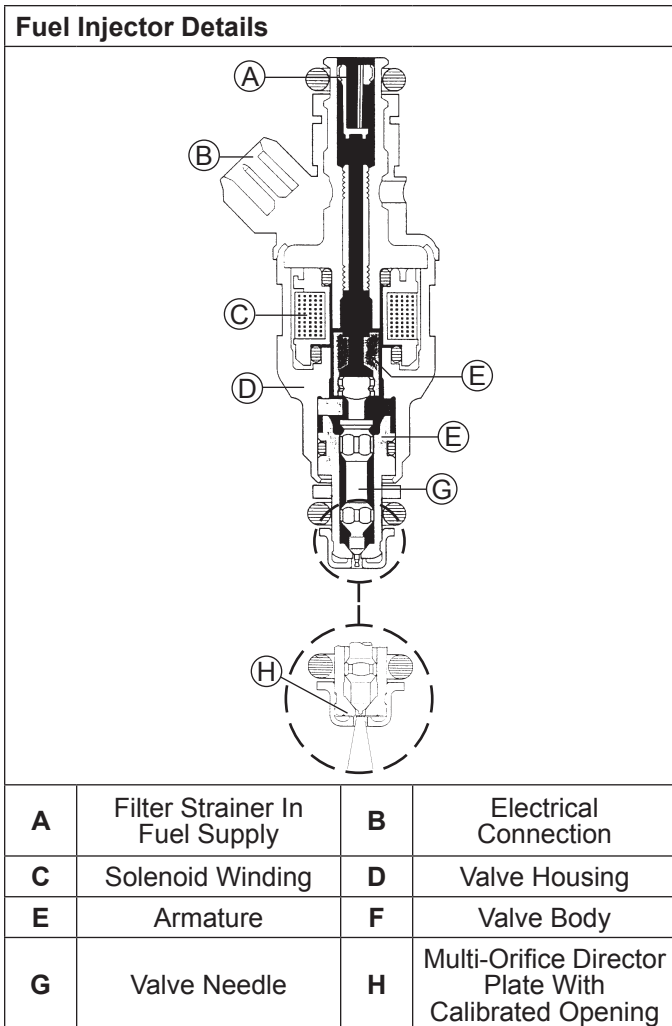

Injector problems typically fall into three general categories: electrical, dirty/clogged, or leakage. An electrical problem usually causes one or both of injectors to stop functioning. Several methods may be used to check if injectors are operating.

1. With engine running at idle, feel for operational vibration, indicating that they are opening and closing.
2. When temperatures prohibit touching, listen for a buzzing or clicking sound with a screwdriver or mechanic's stethoscope.

NOTE: Do not apply voltage to fuel injector(s). Excessive voltage will burn out injector(s). Do not ground injector(s) with ignition ON. Injector(s) will open/turn on if relay is energized.

3. Disconnect electrical connector from an injector and listen for a change in idle performance (only running on one cylinder) or a change in injector noise or vibration.

If an injector is not operating, it can indicate either a bad injector, or a wiring/electrical connection problem. Check as follows:

1. Disconnect electrical connector from both injectors. Plug a 12 volt noid light (part of EFI Service Kit, see Tools and Aids) into one connector.

2. Make sure all safety switch requirements are met. Crank engine and check for flashing of test light. Repeat test at other connector.
 - a. If flashing occurs, use an ohmmeter (Rx1 scale) and check resistance of each injector across two terminals. Proper resistance is 12-20 Ω . If injector resistance is correct, check whether connector and injector terminals are making a good connection. If resistance is not correct, replace injector following steps 1-8 and 13-16 below.
 - b. If no flashing occurs, reattach connectors to both injectors. Disconnect main harness connector from ECU and connector from relay. Set ohmmeter to Rx1 scale and check injector circuit resistance as follows.

"24 Pin" (MSE 1.0) Plastic-Cased ECU:

Check resistance between relay terminal #87 and pin #16 in main connector. Then check resistance between relay terminal

#87 and pin #17. Resistance should be 4-15 Ω for each circuit. "32 Pin" (MSE 1.1)

Plastic-Cased ECU: Check resistance between relay terminal #87 and pin #14 in main connector. Then check resistance between relay terminal #87 and pin #15. Resistance should be 4-15 Ω for each circuit.

Check all electrical connections, connectors, and wiring harness leads if resistance is incorrect.

Injector leakage is very unlikely, but in those rare instances it can be internal (past tip of valve needle), or external (weeping around injector body). Loss of system pressure from leakage can cause hot restart problems and longer cranking times. To check for leakage it will be necessary to loosen or remove blower housing which may involve removing engine from unit.

Injector Inspection Points

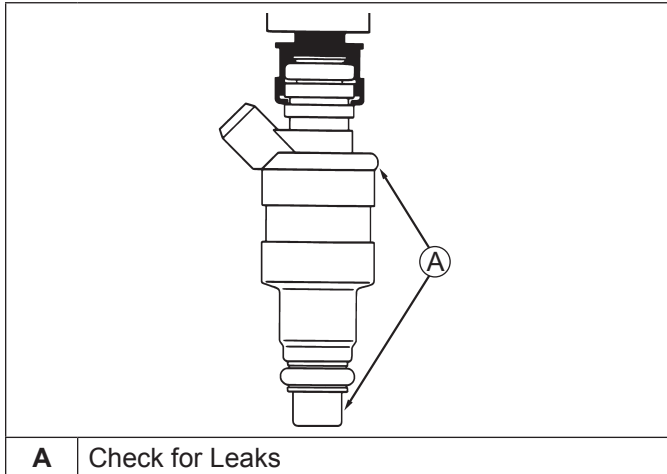

A Check for Leaks

1. Engine must be cool. Depressurize fuel system through test valve in fuel rail.
2. Disconnect spark plug leads from spark plugs.
3. Remove air cleaner outer cover, inner wing nut, element cover and air cleaner element/precleaner. Service air cleaner components as required.
4. Remove screws securing air cleaner base to throttle body manifold. Remove air cleaner base to permit access to injectors. Check condition of air cleaner base gasket, replace if necessary.
5. Remove flywheel screen if it overlaps blower housing.
6. If engine has a radiator-type oil cooler mounted to blower housing, remove oil cooler mounting screws.
7. Remove blower housing mounting screws. Note location of plated (silver) screw attaching rectifier/regulator ground lead. Remove blower housing.
8. Thoroughly clean area around and including throttle body/manifold and injectors.
9. Disconnect throttle linkage and damper spring from throttle lever. Disconnect TPS lead from harness.
10. Remove manifold mounting bolts and separate throttle body/manifold from engine leaving TPS, fuel rail, air baffle, injectors and line connections intact. Discard old gaskets.
11. Position manifold assembly over an appropriate container and turn key switch ON to activate fuel pump and pressurize system. Do not turn switch to START position.
12. If either injector exhibits leakage of more than two to four drops per minute from tip, or shows any sign of leakage around outer shell, turn ignition switch off and replace injector as follows.
13. Depressurize fuel system following procedure in fuel warning on page. Remove fuel rail mounting screws.
14. Clean any dirt accumulation from sealing/mounting area of faulty injector(s) and disconnect electrical connector(s).
15. Pull retaining clip off top of injector(s). Disconnect fuel rail and remove injector(s) from manifold.

16. Reverse appropriate procedures to install new injector(s) and reassemble engine. Use new O-Rings any time an injector is removed (new replacement injectors include new O-Rings). Lubricate O-Rings lightly with oil. Torque fuel rail and blower housing mounting screws to 3.9 N·m (35 in. lb.), and intake manifold and air cleaner mounting screws to 9.9 N·m (88 in. lb.).

Injector problems due to dirt or clogging are generally unlikely due to design of injectors, high fuel pressure, and detergent additives in gasoline. Symptoms that could be caused by dirty/clogged injectors include rough idle, hesitation/stumble during acceleration, or triggering of fault codes related to fuel delivery. Injector clogging is usually caused by a buildup of deposits on director plate, restricting flow of fuel, resulting in a poor spray pattern. Some contributing factors to injector clogging include higher than normal operating temperatures, short operating intervals, and dirty, incorrect, or poor quality fuel. Cleaning of clogged injectors is not recommended; they should be replaced. Additives and higher grades of fuel can be used as a preventative measure if clogging has been a problem.

NOTE: **Do not** ground coils with ignition ON, as they may overheat or spark.

Ignition Testing

1. Disconnect main harness connector from ECU.
 - "24 Pin" (MSE 1.0) Plastic-Cased ECU: Locate pins #22 and #23 in 24 pin connector. See page .
 - "32 Pin" (MSE 1.1) Plastic Cased ECU: Locate pins #30 and #31 in 32 pin connector. See page.
2. Disconnect connector from relay and locate terminal #87 in connector.
3. Using an ohmmeter set on the Rx1 scale, check resistance in circuits as follows:
 - "24 Pin" (MSE 1.0) Plastic-Cased ECU: Check between terminal #87 and pin #22 for coil #1. Repeat test between terminal #87 and pin #23 for coil #2.
 - "32 Pin" (MSE 1.1) Plastic-Cased ECU: Check between terminal #87 and pin #30 for coil #1. Repeat test between terminal #87 and pin #31 for coil #2.

A reading of 1.8-4.0 Ω in each test indicates that wiring and coil primary circuits are OK.

 - a. If reading(s) are not within specified range, check and clean connections and retest.
 - b. If reading(s) are still not within specified range, test coils separately from main harness as follows:
 1. Disconnect red and black primary leads from coil terminals.
 2. Connect an ohmmeter set on the Rx1 scale to primary terminals. Primary resistance should be 1.8-2.5 Ω .

EFI SYSTEM-BOSCH

3. Disconnect secondary lead from spark plug. Connect an ohmmeter set on Rx10K scale between spark plug boot terminal and red primary terminal. Secondary resistance should be 13,000-17,500 Ω .
4. If secondary resistance is not within specified range, unscrew spark plug lead nut from coil secondary tower and remove plug lead. Repeat step b. 3, testing from secondary tower terminal to red primary terminal. If resistance is now correct, coil is good, but spark plug lead is faulty, replace lead. If step b. 2 resistance was incorrect and/or secondary resistance is still incorrect, coil is faulty and needs to be replaced.

Wiring harness used in EFI system connects electrical components, providing current and ground paths for system to operate. All input and output signaling occurs through a special all weather connector that attaches and locks to ECU.

Condition of wiring, connectors, and terminal connections is essential to system function and performance. Corrosion, moisture, and poor connections are more likely cause of operating problems and system errors than an actual component.

Fuel Pump

Fuel pumps are non-serviceable and must be replaced if determined to be faulty. If a fuel delivery problem is suspected, make certain pump is being activated through relay, all electrical connections are properly secured, fuses are good, and a minimum of 7.0 volts is being supplied. If during cranking, voltage drops below 7.0 volts, a reduction of fuel pressure may occur resulting in a lean starting condition. If required, testing fuel pump and relay may be conducted.

1. Connect black hose of Pressure Tester (part of EFI Service Kit, see Tools and Aids) to test valve in fuel rail. Route clear hose into a portable gasoline container or equipment fuel tank.
2. Turn on key switch to activate pump and check system pressure on gauge. If system pressure of 39 psi \pm 3 is observed, relay, fuel pump, and regulator are working properly. Turn key switch off and depress valve button on tester to relieve system pressure.
 - a. If pressure is too high, and regulator is outside tank (just down line from pump), check that return line from regulator to tank is not kinked or blocked. If return line is good, replace regulator (see Regulator on page).
 - b. If pressure is too low, install in-line "T" between pump and regulator and retest pressure at that point. If it is too low there also, replace fuel pump.
3. If pump did not activate (step 2), disconnect plug from fuel pump. Connect a DC voltmeter across terminals in plug, turn on key switch and observe if a minimum of 7 volts is present. If voltage is between 7 and 14, turn key switch off and connect an ohmmeter between terminals on pump to check for continuity.

- a. If there was no continuity between pump terminals, replace fuel pump.
 - b. If voltage was below 7, test wiring harness and relay as covered in Electrical Relay.
4. If voltage at plug was good, and there was continuity across pump terminals, reconnect plug to pump, making sure you have a good connection. Turn on key switch and listen for pump to activate.
 - a. If pump starts, repeat steps 1 and 2 to verify correct pressure.
 - b. If pump still does not operate, replace it.

Fuel Pressure Regulator Details

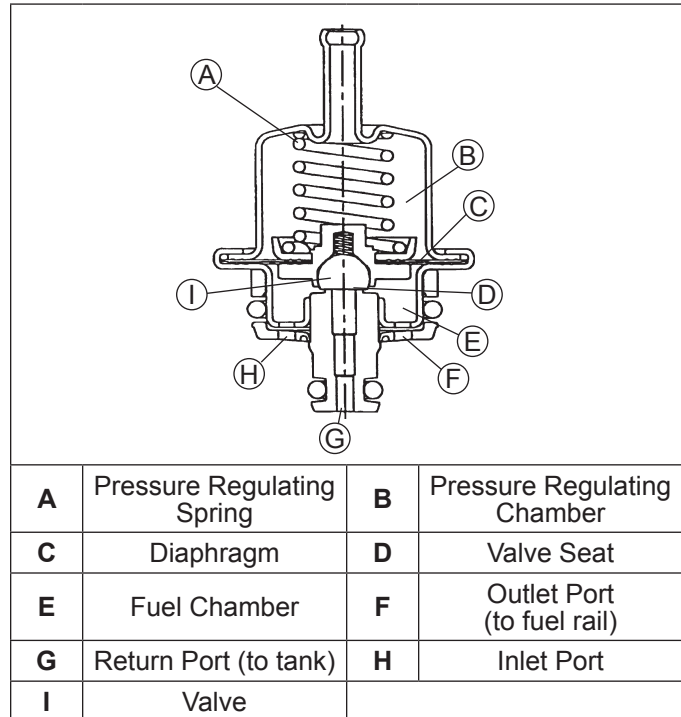

Depending on application, regulator may be located in fuel tank along with fuel pump, or outside tank just down line from pump. Regulator is a sealed, non-serviceable assembly. If it is faulty, it must be separated from base/holder assembly and replaced as follows:

1. Shut engine off, make sure engine is cool, and disconnect negative (-) battery cable.
2. Depressurize fuel system through test valve in fuel rail.
3. Access regulator assembly as required and clean any dirt or foreign material away from area.
4. **External Regulator-**
 - a. Remove screws securing mounting bracket to regulator housing. Remove O-Ring and pull regulator out of housing.
 - b. Remove snap ring and remove regulator from base/holder.

Internal (In-Tank) Regulator-

Remove screws securing retaining ring and regulator in base/holder assembly. Grasp and pull regulator out of base/holder.

5. Always use new O-Rings and hose clamps when installing a regulator. A new replacement regulator will have new O-Rings already installed. Lubricate O-Rings (external regulator) with light grease or oil.
6. Install new regulator by carefully pushing and rotating it slightly into base or housing.
 - a. External Regulators with Square Base Housing Only; Install a new O-Ring between regulator and mounting bracket. Set mounting bracket into position.
 - b. Secure the regulator in base with original retaining ring or screws. Be careful not to dent or damage body of regulator as operating performance can be affected.
7. Reassemble and connect any parts removed in step 3.
8. Reconnect negative (-) battery cable.
9. Recheck regulated system pressure at fuel rail test valve.

Fuel Rail

Fuel rail is mounted to throttle body/intake manifold. No specific servicing is required unless operating conditions indicate that it needs internal cleaning or replacement. It can be detached by removing mounting screws and injector retaining clips. Thoroughly clean area around all joints and relieve any pressure before starting any disassembly.

Throttle Body/Intake Manifold Assembly

Throttle body/intake manifold is serviced as an assembly, with throttle shaft, TPS, throttle plates, and idle speed adjusting screw installed. Throttle shaft rotates on needle bearings (non-serviceable), capped with rubber seals to prevent air leaks. A throttle shaft repair kit is available to replace shaft if worn or damaged. Appropriate TPS Initialization Procedure must be performed after any throttle shaft service.

Idle Speed Adjustment (RPM)

Adjustment Procedure

1. Make sure there are no fault codes present in ECU memory.
2. Start engine and allow it to fully warm up and establish closed looped operation (approximately 5-10 min.).
3. Place throttle control in IDLE/SLOW position and check idle speed with a tachometer. Turn idle speed screw in or out as required to obtain 1500 RPM, or idle speed specified by equipment manufacturer.
4. Idle speed adjustment can affect high idle speed setting. Move throttle control to full throttle position and check high idle speed. Adjust as necessary to 3750 RPM, or speed specified by equipment manufacturer.

Idle Speed Screw Dampening Spring

Idle Speed Screw Details

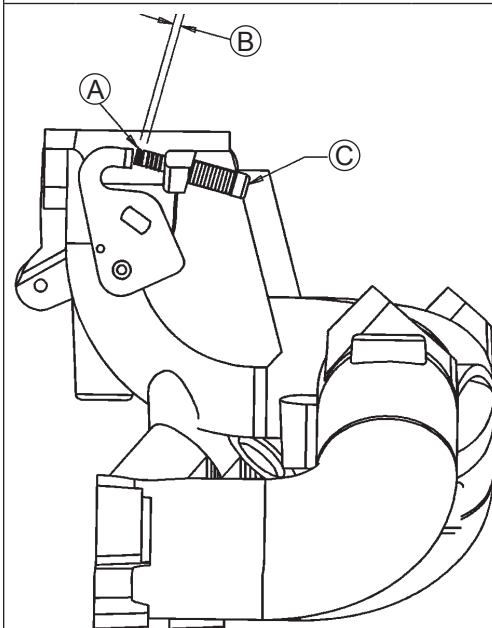

A	Dampening Spring (Some Models)	B	1-3 mm (0.039-0.117 in.) Exposed Length Off End Of Adjustment Screw
C	Idle Speed Screw		

A small dampening spring is attached to end of idle speed screw of some EFI engines to help stabilize no load operating speeds.

Idle speed adjustment procedure remains same for engines with or without a dampening spring. Typically, no periodic servicing is necessary in this area. If however, removal/replacement of dampening spring is required, reinstall it as follows:

1. Thread spring onto end of idle screw leaving 1-3 mm (0.039-0.117 in.) of spring extending beyond end of idle speed screw.
2. Secure spring onto screw with a small amount of Permabond™ LM-737 or equivalent Loctite® adhesive. Do not get any adhesive on free coils of spring.
3. Start engine and recheck idle speed settings, after sufficient warm up. Readjust as required.

Initial Governor Adjustment

Initial governor adjustment is especially critical on EFI engines because of accuracy and sensitivity of electronic control system. Incorrect adjustment can result in overspeed, loss of power, lack of response, or inadequate load compensation. If you encounter any of these symptoms and suspect them to be related to governor setting, following should be used to check and/or adjust governor and throttle linkage.

EFI SYSTEM-BOSCH

If governor/throttle components are all intact, but you think there may be a problem with adjustment, follow Procedure A to check setting. If governor lever was loosened or removed, go immediately to Procedure B to perform initial adjustment.

A. Checking Initial Adjustment

1. Unsnap plastic linkage bushing attaching throttle linkage to governor lever. Unhook damper spring from lever, separate linkage from bushing, and remove bushing from lever. Mark hole position and unhook governor spring from governor lever.
2. Check if engine has a high-speed throttle stop screw installed in manifold casting boss.
 - a. On engines without a stop screw, pivot throttle shaft and plate assembly into FULL THROTTLE position. Insert a 1.52 mm (0.060 in.) feeler gauge between rear tang of throttle shaft plate and underside of manifold boss. Use a locking pliers (needle nose works best) to temporarily clamp parts in this position.
 - b. On engines with a stop screw, pivot throttle shaft and plate into FULL THROTTLE position, so tang of throttle shaft plate is against end of high-speed stop screw. Temporarily clamp in this position.
3. Rotate governor lever and shaft counterclockwise until it stops. Use only enough pressure to hold it in that position.
4. Check how end of throttle linkage aligns with bushing hole in governor lever. It should fall in center of hole. If it doesn't, perform adjustment procedure as follows.

B. Setting Initial Adjustment

1. Check split where clamping screw goes through governor lever. There should be a gap of at least 1/32". If tips are touching and there is no gap present, lever should be replaced. If not already installed, position governor lever on cross shaft, but leave clamping screw loose.
2. Follow instructions in Step 2 of Checking Initial Adjustment, then reattach throttle linkage to governor lever with bushing clip. It is not necessary to reattach damper or governor springs at this time.
3. Insert a nail into hole in top of cross shaft. Using light pressure, rotate governor shaft counterclockwise as far as it will turn, then torque nut on clamping screw to 6.8 N·m (60 in. lb.). Make sure that governor arm has not twisted up or down after nut has been tightened.
4. Verify that governor has been set correctly. With linkage still retained in FULL THROTTLE position (Step 2), unsnap bushing clip, separate linkage from bushing, and remove bushing from lever. Follow Steps 3 and 4 in Checking Initial Adjustment.
5. Reconnect dampening spring into its governor lever hole from bottom. Reinstall bushing and reattach throttle linkage. Reattach governor spring in marked hole.
6. Start engine and allow it to fully warm up and establish closed loop operation (approximately 5-10 min.). Check speed settings and adjust as necessary, first low idle speed, and then high speed setting.

TROUBLESHOOTING

Troubleshooting Guide

Condition	Possible Cause
Engine Starts Hard or Fails to Start When Cold.	Fuel pump not running.
	Faulty spark plugs.
	Old/stale fuel.
	Incorrect fuel pressure.
	Speed sensor loose or faulty.
	TPS offset incorrect (initialization).
	Engine temperature sensor faulty.
	Engine temp sensor faulty.
	Faulty coils.
	Low system voltage.
Faulty injectors.	

Engine starts hard or fails to start when hot	Faulty spark plugs.
	Fuel pump not running.
	Fuel pressure low.
	Insufficient fuel delivery.
	TPS offset incorrect (Initialization).
	Speed sensor loose or faulty.
	TPS faulty.
	Engine temperature sensor faulty.
	Faulty injectors.
Engine stalls or idles roughly (cold or warm)	Faulty spark plugs.
	Insufficient fuel delivery.
	TPS offset incorrect.
	TPS faulty.
	Faulty engine temperature sensor.
	Faulty injectors.
Engine misses, hesitates, or stalls under load	Fuel injector(s), fuel filter, fuel line, or fuel pick-up dirty/restricted.
	Dirty air cleaner.
	Insufficient fuel pressure or fuel delivery.
	Vacuum (intake air) leak.
	Improper governor setting, adjustment or operation.
	Speed sensor malfunction.
	TPS faulty, mounting problem or TPS Initialization Procedure incorrect.
	Bad coil(s), spark plug(s), or wires.
Low Power	Faulty/malfunctioning ignition system.
	Dirty air filter.
	Insufficient fuel delivery.
	Improper governor adjustment.
	Plugged/restricted exhaust.
	One injector not working.
	Basic engine problem exists.
	TPS faulty or mounting exists.
	Throttle plates in throttle body/intake manifold not fully opening to WOT stop (if so equipped).

EFI system is a 12 VDC negative ground system, designed to operate down to a minimum of 7.0 volts. If system voltage drops below this level, operation of voltage sensitive components such as ECU, fuel pump, and injectors will be intermittent or disrupted, causing erratic operation or hard starting. A fully charged, 12 volt battery with a minimum of 350 cold cranking amps is important in maintaining steady and reliable system operation. Battery condition and state of charge should always be checked first when troubleshooting an operational problem.

Keep in mind that EFI-related problems are more often caused by wiring harness or connections than by EFI components. Even small amounts of corrosion or oxidation on terminals can interfere with milliamp currents used in system operation. Cleaning connectors and grounds will solve problems in many cases.

In an emergency situation, simply disconnecting and reconnecting connectors may clean up contacts enough to restore operation, at least temporarily.

If a fault code indicates a problem with an electrical component, disconnect ECU connector and test for continuity between component connector terminals and corresponding terminals in ECU connector using an ohmmeter. Little or no resistance should be measured, indicating that wiring of that particular circuit is OK. An illustrated listing of numerical terminal locations, for each style of ECU/connector is provided on pages 130, 132, and 134.

EFI SYSTEM-BOSCH

"35 Pin" (MA 1.7) Metal-Cased ECU Systems

Pin #	Component	
1	Ignition Coil #1	
2	Not Used	
3	Engine Speed Sensor	
4	ECU Production Test Terminal	
5	Not Used	
6	Not Used	
7	Not Used	
8	TPS Initialization Terminal	
9	Engine Ground	
10	O2 Sensor	
11	Not Used	
12	Throttle Position Sensor	
13	Not Used	
14	Oil Temperature Sensor	
15	Not Used	
16	ECU Permanent Battery Voltage	
17	ECU Switched Battery Voltage	
18	Engine Ground	
19	Ignition Coil #2	
20	Vehicle Ground	
21	Engine Speed Sensor	
22	Not Used	
23	Not Used	
24	Not Used	
25	Throttle Position Sensor	
26	Not Used	
27	Throttle Position Sensor/Oil Temperature Sensor	
28	Power Relay	
29	Not Used	
30	Not Used	
31	Malfunction Indicator Light	
32	Not Used	
33	Vehicle Ground	
34	Not Used	
35	Fuel Injectors	

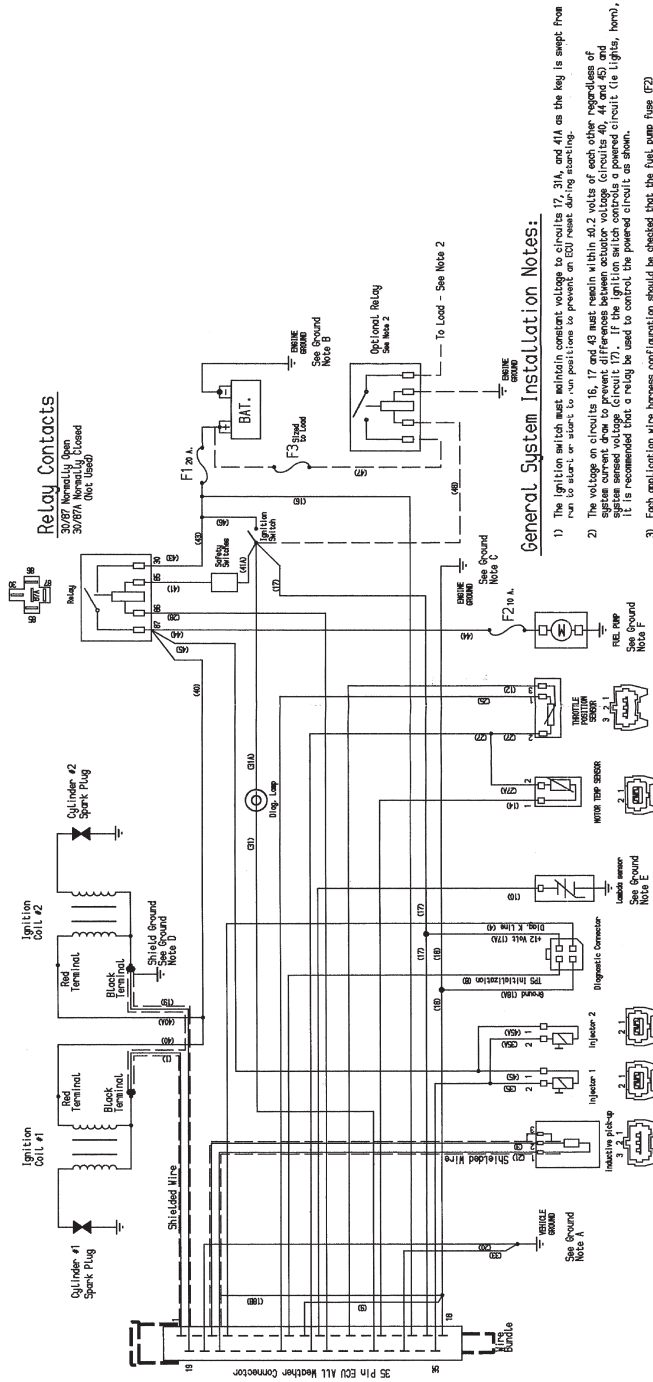

Grounding Notes

Note	Item	Instruction
A	Injector/Ignition Output Driver	Attach to chassis as close to ECU as possible
B	Battery	Attach to engine block near starter
C	ECU	Attach to engine block near blower housing
D	Shield	Attach to engine block near coil #2. The Lambda ground to the engine via the exhaust gasket. If a slip joint sensor is used, a grounding strap from the engine to the slip joint near the Lambda sensor is required.
E	Lambda Sensor	Attach to chassis
F	Fuel Pump	Attach to chassis
.	.	.

EFI SYSTEM-BOSCH

"24 Pin" (MSE 1.0) Plastic-Cased ECU Systems

Pin #	Component
1	Permanent Battery Voltage
2	Switched Ignition Voltage
3	Safety Switch
4	Throttle Position Sensor (TPS) and Temperature Sensor Ground
5	Not Used
6	Oil Temperature Sensor Input
7	Not Used
8	Throttle Position Sensor (TPS) Input
9	Speed Sensor Input
10	Speed Sensor Ground
11	Oxygen Sensor Input
12	Not Used (Oxygen Sensor Ground if needed)
13	Diagnostic Line
14	Throttle Position Supply Voltage
15	Battery Ground
16	Injector 1 Output
17	Injector 2 Output
18	Main Relay Output
19	Malfunction Indicator Light (MIL)
20	Not Used (Tach Output if needed)
21	Not Used
22	Ignition Coil #1 Output
23	Ignition Coil #2 Output
24	TPS Initialization Terminal

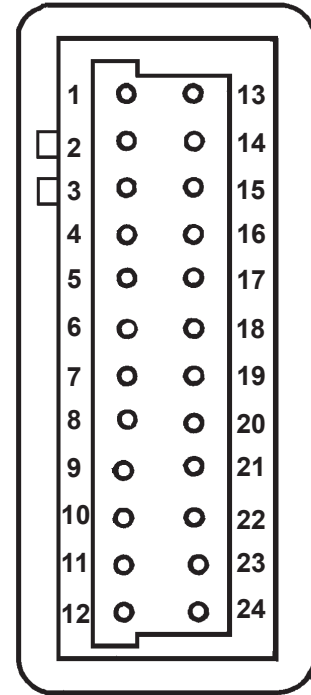

Connector
J1

PIN	FUNCTION	REMARKS
1	Battery	Permanent
2	Switched Ignition	
3	Safety Switch	
4	Ignition	
5	Safety Switch	
6	Not Used	
7	Motor Temp Input	
8	VR Input	
9	VR Input (-)	
10	VR Input (+)	
11	Lambda Input	
12	K-Line	Ground (if need)
13	W-Lamp	
14	W-Lamp	
15	W-Lamp	
16	W-Lamp	
17	W-Lamp	
18	W-Lamp	
19	W-Lamp	
20	W-Lamp	
21	W-Lamp	
22	W-Lamp	
23	W-Lamp	
24	W-Lamp	

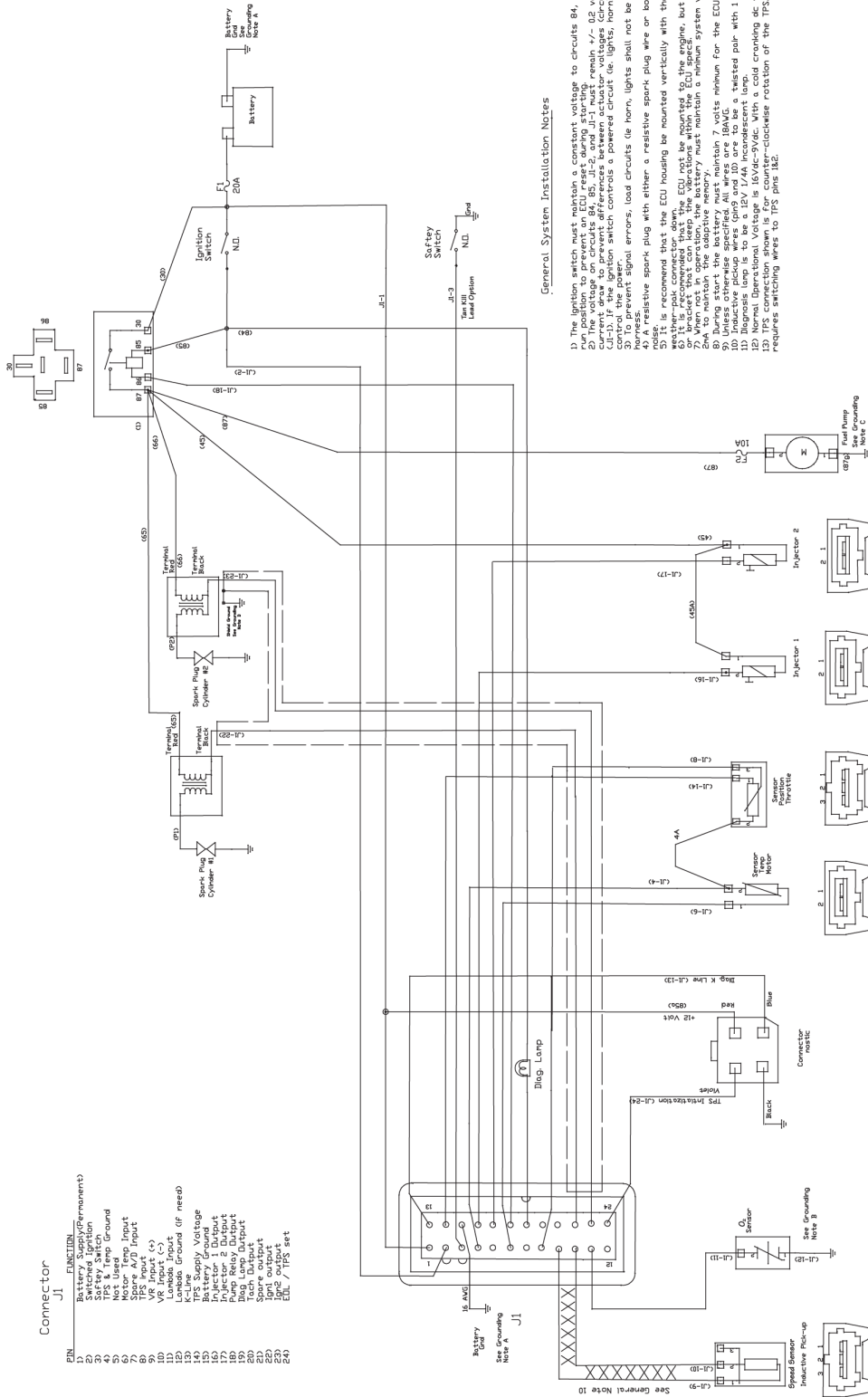

General System Installation Notes

- The ignition switch must maintain a constant voltage to circuits 84, 85, and J1-2 as the key is swept from ON to OFF.
- The voltage on circuits 84, 85, J1-2, and J1-1 must remain +/- 0.2 volts of each other regardless of system voltage.
- When not connected to the battery, the ignition switch must maintain a minimum of 7 volts with a current draw of 20mA to maintain the adaptive memory.
- When not connected to the battery, the ignition switch must maintain a minimum of 7 volts with a current draw of 20mA to maintain the adaptive memory.
- Unless otherwise specified, all wires are 18AWG.
- Inductive pickup wires (pin 9 and 10) are to be a twisted pair with 1 twist per inch.
- Normal Operational Voltage is 16Vdc-2Vdc. With a cold cranking dc voltage of 7Volts.
- TPS connection shown is for counter-clockwise rotation of the TPS. Clockwise rotation requires switching wires to TPS pins 1&2.

GROUNDING NOTES

- 1&2:** Battery
 - A:** Lambda Sensor
 - C:** Fuel Pump
 - D:** Shield
- Attached to engine block near starter.
The sensor of this sensor is the surface.
If this located sensor is used pin 12 is lambda ground.
If astip joint is used, a grounding strap is required.
Attached to chassis.
Attached to engine block close to the col.

EFI SYSTEM-BOSCH

"32 Pin" (MSE 1.1) Plastic-Cased ECU Systems

Pin #	Component
1	Permanent Battery Voltage
2	Switched Battery Voltage
3	TPS Set; "Auto-Learn" Initialization Terminal
4	Throttle Position Sensor (TPS) and Temperature Sensor Ground
5	Not Used
6	Oil Temperature Sensor Input
7	Not Used
8	Throttle Position Sensor (TPS) Input
9	Speed Sensor Input (+)
10	Speed Sensor Ground (-)
11	Not Used
12	Not Used
13	Not Used
14	Injector 1 Output
15	Injector 2 Output
16	Not Used
17	Diagnostic Line
18	Throttle Position Sensor Supply Voltage
19	Battery Ground
20	Oxygen Sensor Input
21	Battery Ground (Secondary)
22	Not Used
23	Not Used
24	Not Used
25	Safety Switch Input
26	Not Used
27	Not Used
28	Main Relay Output
29	Malfunction Indicator Light (MIL)
30	Ignition Coil #1 Output
31	Ignition Coil #2 Output
32	Not Used

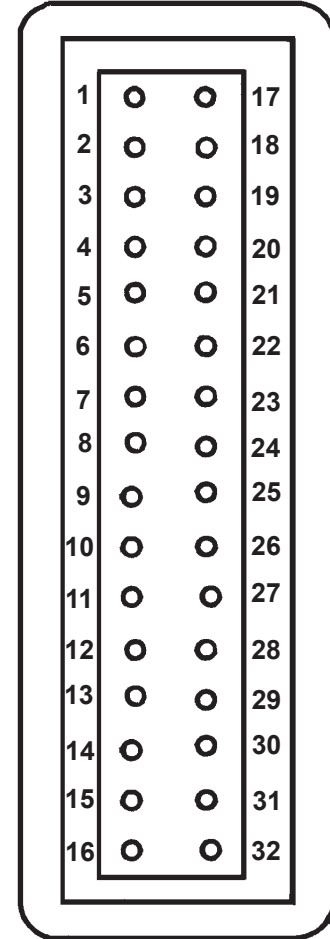

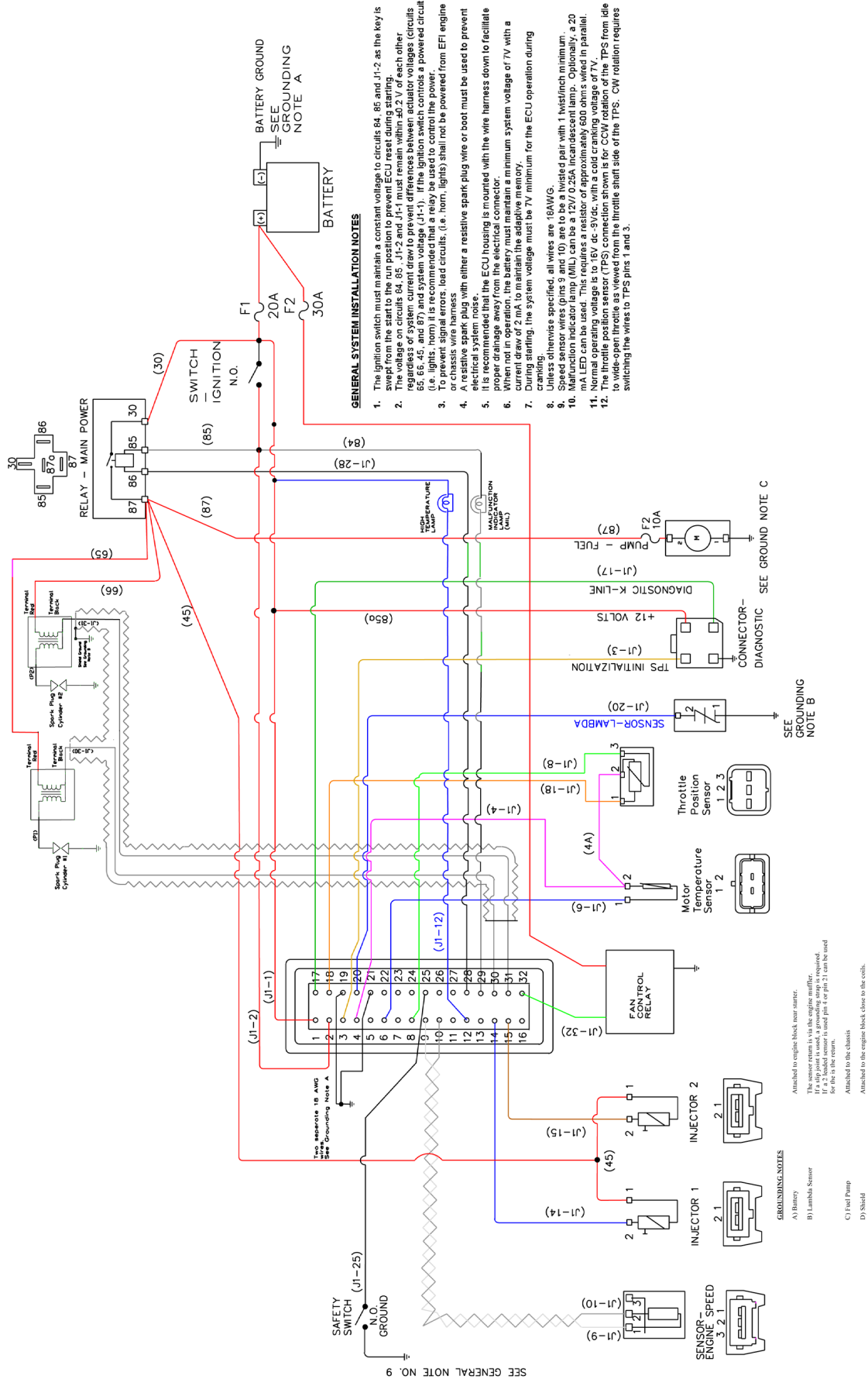

GENERAL SYSTEM INSTALLATION NOTES

1. The ignition switch must maintain a constant voltage to circuits 84, 86 and J1-2 as the key is swept from the start to the run position to prevent ECU reset during starting.
2. The voltage on circuits 84, 85, J1-2 and J1-1 must remain within ±0.2 V of each other regardless of system current draw to prevent differences between actuator voltages (circuits 65, 66, 45, and 87) and system voltage (J1-1). If the ignition switch controls a powered circuit (i.e. lights, horn) it is recommended that a relay be used to control the power.
3. The ignition switch must be able to handle the load of the horn, lights and not be powered from the engine or chassis wire harness.
4. A resistive spark plug wire or boot must be used to prevent electrical system noise.
5. It is recommended that the ECU housing is mounted with the wire harness down to facilitate proper drainage away from the electrical connector.
6. When not in operation, the battery must maintain a minimum system voltage of 7V with a current draw of 2 mA to maintain the adaptive memory.
7. During cranking, the system voltage must be 7V minimum for the ECU operation during cranking.
8. Unless otherwise specified, all wires are 18AWG.
9. Speed sensor wires (pins 9 and 10) are to be a twisted pair with 1 twist/inch minimum.
10. Malfunction indicator lamp (MIL) can be a 12V/0.25A incandescent lamp. Optionally, a 20 mA LED can be used. This requires a resistor of approximately 600 ohms wired in parallel.
11. Normal operating voltage is to 16V dc - 5Vdc, with a cold cranking voltage of 7V.
12. The throttle position sensor (TPS) connection shown is for CCW rotation of the TPS from idle. The throttle cable must be connected to the throttle start side of the TPS. CW rotation requires switching the wires to TPS pins 1 and 3.

- GROUNDING NOTES**
- A) Battery
 - B) Lambda Sensor
 - C) Fuel Pump
 - D) Shield
- Attached to engine block near source.
The sensor return is via the engine muffler.
If a slip-joint is used, a grounding strap is required.
If a slip-joint is used, a grounding strap is required for this is the return.
Attached to the chassis.
Attached to the engine block, close to the coils.

EFI SYSTEM-BOSCH

Fuel System



WARNING: Fuel System Under Pressure!

Fuel system operates under high pressure. System pressure must be relieved through test valve in fuel rail prior to servicing or removing any fuel system components. Do not smoke or work near heaters or other fire hazards. Have a fire extinguisher handy and work only in a well-ventilated area.

Function of fuel system is to provide sufficient delivery of fuel at system operating pressure of 39 psi \pm 3. If an engine starts hard, or turns over but will not start, it may indicate a problem with EFI fuel system. A quick test will verify if system is operating.

1. Disconnect and ground spark plug leads.
2. Complete all safety interlock requirements and crank engine for approximately 3 seconds.
3. Remove spark plugs and check for fuel at tips.
 - a. If there is fuel at tips of spark plugs, fuel pump and injectors are operating.
 - b. If there is no fuel at tips of spark plugs, check following.
1. Make sure fuel tank contains clean, fresh, proper fuel.
2. Make sure that vent in fuel tank is open.
3. Make sure fuel tank valve (if so equipped) is fully opened.
4. Make sure battery is supplying proper voltage.
5. Check that fuses are good, and that all electrical and fuel line connections are good.
6. Test fuel pump and relay operation as described earlier under Fuel Pump.

Fault Codes

ECU continuously monitors engine operation against preset performance limits. If operation is outside limits, ECU activates MIL and stores a diagnostic code in its fault memory. If component or system returns to proper function, ECU will eventually self-clear fault code and turn off MIL. If MIL stays illuminated, it warns customer that dealer service is required. Upon receipt, dealer technician can access fault code(s) to help determine what portion of system is malfunctioning. 2-digit blink codes available based upon style of ECU are listed on pages 137, 138, and 139.

Codes are accessed through key switch and displayed as blinks or flashes of MIL. Access codes as follows.

1. Start with key switch off.
2. Turn key switch on-off-on-off-on, leaving it on in third sequence. Time between sequences must be less than 2.5 seconds.
3. Any stored fault codes will then be displayed as a series of MIL blinks (from 2 to 6) representing first digit, followed by a pause, and another series of blinks (from 1 to 6) for second digit.
 - a. It's a good idea to write down codes as they appear, as they may not be in numerical sequence.
 - b. Code 61 will always be last code displayed, indicating end of code transmission. If code 61 appears immediately, no other fault codes are present.

Example of Diagnostic Display

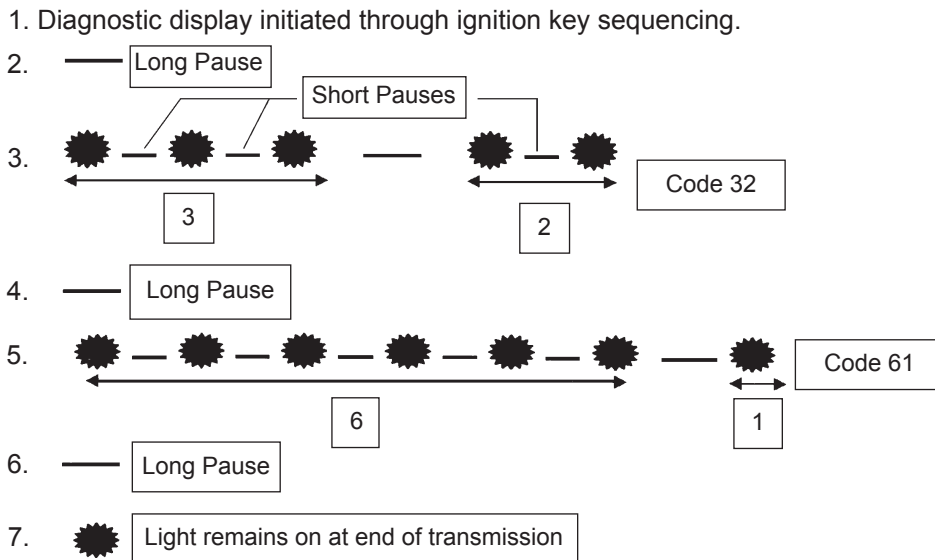

After the problem has been corrected, fault codes may be cleared as follows.

1. Disconnect negative (-) battery cable from battery terminal, or remove main fuse for ECU for approximately 1 minute.
2. Reconnect cable and tighten securely, or reinstall main fuse. Start engine and allow it to run for several minutes. MIL should remain off if problem was corrected, and fault codes should not reappear (codes 31, 32, 33, and 34 may require 10-15 minutes of running to reappear).

Following chart lists fault codes, what they correspond to, and what visual indications will be. Following chart is a list of individual codes with an explanation of what triggers them, what symptoms might be expected, and probable causes.

Blink Code	OBD2 P-Code Applicable to: "32 Pin" (MSE 1.1) ECU/System Only	Connection or Failure Description	"35 Pin" (MA 1.7) Metal-Cased ECU/System	"24 Pin" (MSE 1.0) Plastic-Cased ECU/System	"32 Pin" (MSE 1.1) Plastic-Cased ECU/System	Note
-	-	No RPM Signal	Y	Y	Y	
21	P0335	Loss of Synchronization	Y	Y	Y	
22	P0120	TPS-Signal Implausible	N	N	N	2
22	P0122	TPS-Open or Short Circuit to Ground	Y	Y	Y	
22	P0123	TPS - Short Circuit to Battery	Y	Y	Y	
23	P0601	Defective ECU	Y	Y	Y	
24		Engine Speed Sensor	Y	Y	Y	9
31	P0174	System too Lean	Y	Y	Y	6

EFI SYSTEM-BOSCH

Blink Code	OBD2 P-Code Applicable to: "32 Pin" (MSE 1.1) ECU/System Only	Connection or Failure Description	"35 Pin" (MA 1.7) Metal-Cased ECU/System	"24 Pin" (MSE 1.0) Plastic-Cased ECU/System	"32 Pin" (MSE 1.1) Plastic-Cased ECU/System	Note
31	P0132	O ₂ Sensor Circuit: Shorted to Battery	Y	N	Y	3
32	P0134	O ₂ Sensor Circuit: No Activity Detected	N	N	N	8
33	P0175	System too Rich	Y	Y	Y	7,8
33	P0020	O ₂ Sensor Control at Upper Limit	Y	Y	Y	8
34	P0171	Maximum Adaption Limit Reached	Y	Y	Y	8
34	P0172	Minimum Adaption Limit Reached	Y	Y	Y	8
42	P0117	Temperature Sensor Circuit: Shorted to Ground	Y	Y	Y	
42	P0118	Temperature Sensor Circuit: Open Circuit or Short to Battery	Y	Y	Y	
43	N/A	Failure Completing Autolearn - TPS Offset below minimum allowable limit	N/A	N/A	Y	
44	N/A	Failure Completing Autolearn - TPS offset above maximum allowable limit	N/A	N/A	Y	
51	P1260	Injector 1-Open Circuit	N/A	N/A	Y	
51	P0261	Injector 1-Short Circuit to Ground	N/A	N/A	Y	
51	P0262	Injector 1-Short Circuit to Battery	N/A	N/A	Y	
52	P1263	Injector 2 - Open Circuit	N/A	N/A	Y	
52	P0264	Injector 2-Short Circuit to Ground	N/A	N/A	Y	
52	P0265	Injector 2-Short Circuit to Batt	N/A	N/A	Y	
55	P1651	Diagnostic Lamp - Open Circuit	N/A	N/A	Y	
55	P1652	Diagnostic Lamp - Short Circuit to Ground	N/A	N/A	Y	
55	P1653	Diagnostic Lamp-Short Circuit to Battery	N/A	N/A	Y	

Blink Code	OBD2 P-Code Applicable to: "32 Pin" (MSE 1.1) ECU/System Only	Connection or Failure Description	"35 Pin" (MA 1.7) Metal-Cased ECU/System	"24 Pin" (MSE 1.0) Plastic-Cased ECU/System	"32 Pin" (MSE 1.1) Plastic-Cased ECU/System	Note
56	P1231	Pump Relay-Open Circuit	N/A	N/A	Y	
56	P1232	Pump Relay-Short Circuit to G	N/A	N/A	Y	
56	P1233	Pump Relay-Short Circuit to B	N/A	N/A	Y	
61		End of Code Transmission	Y	Y	Y	

NOTE:

1. Idle Switch not used.
2. Diagnostic of TPS-Signal Implausible is disabled in code.
3. O2 Sensor Short to Battery diagnostic detection is disabled with SAS fuel-cutoff calibrated out.
4. Air Temperature Sensor not used.
5. Temperature Sensor Signal Implausible: diagnostic detection is calibrated out, with TPLAUS set to -50°C.
6. System too Lean used to be O2 Sensor-Short to Ground (P0131).
7. System too Rich used to be O2 Sensor Control at Lower Limit (P0019).
8. Obtainable only with ECU 24 584 28-S or later.
9. Will not blink out.

Code 21

Component:	Engine Speed Sensor		<p>Engine Wiring Harness Related "24 Pin" (MSE 1.0) Plastic-Cased ECU:</p> <ul style="list-style-type: none"> ● Pin circuits 9 and/or 10 wiring or connectors. ● Shielding for pin circuits 9 and/or 10 damaged or not properly grounded. ● Poor or improper grounds in system (battery, ECU oxygen sensor, shielding, fuel pump, ignition output). ● Pin circuits 9 and/or 10 routed near noisy electrical signals (coils, spark plug lead, plug connector). <p>Engine Wiring Harness Related "32 Pin" (MSE 1.1) Plastic-Cased ECU:</p> <ul style="list-style-type: none"> ● Pin circuits 9 and/or 10 wiring or connectors. ● Shielding for pin circuits 9 and/or 10 damaged or not properly grounded. ● Poor or improper grounds in system (battery, ECU, oxygen sensor, shielding, fuel pump, ignition output). ● Pin circuits 9 and/or 10 routed near noisy electrical signals (coils, spark plug lead, plug connector). <p>ECU/Harness Related</p> <ul style="list-style-type: none"> ● ECU-to-harness connection problem. <p>Ignition System Related</p> <ul style="list-style-type: none"> ● Non-resistor spark plug(s) used.
Fault:	ECU receiving inconsistent tooth count signals from speed sensor.		
Condition:	Possible misfire as ECU attempts to resynchronize, during which time fuel and spark calculations are not made.		
Conclusion:	<p>Engine Speed Sensor Related</p> <ul style="list-style-type: none"> ● Sensor connector or wiring. ● Sensor loose or incorrect air gap. ● Flywheel key sheared <p>Speed Sensor Ring Gear Related</p> <ul style="list-style-type: none"> ● Damaged teeth. ● Varying gap (gear loose/out of alignment). <p>Engine Wiring Harness Related "35 Pin" (MA 1.7) Metal-Cased ECU:</p> <ul style="list-style-type: none"> ● Pin circuits 3 and/or 21 wiring or connectors. ● Shielding for pin circuits 3 and/or 21 damaged or not properly grounded. ● Poor or improper grounds in system (battery, ECU, oxygen sensor, shielding, fuel pump, ignition output). ● Pin circuits 3 and/or 21 routed near noisy electrical signals (coils, spark plug lead, plug connector). 		

EFI SYSTEM-BOSCH

Code 22

Component:	Throttle Position Sensor (TPS)
Fault:	Unrecognizable signal is being sent from sensor (too high, too low, inconsistent).
Condition:	A "limp-home" operating mode occurs, with an overall decrease in operating performance and efficiency. Fuel delivery is based upon oxygen sensor and five mapped values only. Rich running (black smoke) will occur until "closed loop" operation is initiated. A stumble or misfire on hard acceleration and/or erratic operation may be exhibited.
Conclusion:	<p>TPS Sensor Related</p> <ul style="list-style-type: none"> • Sensor connector or wiring. • Sensor output affected or disrupted by dirt, grease, oil, wear, or breather tube position (must be to side opposite TPS). • Sensor loose on throttle body manifold. <p>Throttle Body Related</p> <ul style="list-style-type: none"> • Throttle shaft or bearings worn/damaged. <p>Engine Wiring Harness Related "35 Pin" (MA 1.7) Metal-Cased ECU:</p> <ul style="list-style-type: none"> • Pin circuits 12, 25 and/or 27 damaged (wiring or connectors). • Pin circuits 12, 25 and/or 27 routed near noisy electrical signal (coils, alternator). • Intermittent 5 volt source from ECU (pin circuit 25). <p>Engine Wiring Harness Related "24 Pin" (MSE 1.0) Plastic-Cased ECU:</p> <ul style="list-style-type: none"> • Pin circuits 4, 8, and/or 14 damaged (wiring, connectors). • Pin circuits 4, 8, and/or 14 routed near noisy electrical signal (coils, alternator). • Intermittent 5 volt source from ECU (pin circuit 14). <p>Engine Wiring Harness Related "32 Pin" (MSE 1.1) Plastic-Cased ECU:</p> <ul style="list-style-type: none"> • Pin circuits 4, 8, and/or 18 damaged (wiring, connectors). • Pin circuits 4, 8, and/or 18 routed near noisy electrical signal (coils, alternator). • Intermittent 5 volt source from ECU (pin circuit 18). <p>ECU/Harness Related</p> <ul style="list-style-type: none"> • ECU-to-harness connection problem.

Code 23

Component:	ECU
Fault:	ECU is unable to recognize or process signals from its memory.
Condition:	Engine will not run.
Conclusion:	<p>ECU (internal memory problem).</p> <ul style="list-style-type: none"> • Diagnosable only through elimination of all other system/component faults.

Code 24 (Will not blink out)

Component:	Engine Speed Sensor
Fault:	No tooth signal from speed sensor. MIL light will not go out when cranking.
Condition:	None-engine will not start or run as ECU is unable to estimate speed.
Conclusion:	<p>Engine Speed Sensor Related</p> <ul style="list-style-type: none"> • Sensor connector or wiring. • Sensor loose or air gap incorrect. <p>Speed Sensor Wheel Related</p> <ul style="list-style-type: none"> • Damaged teeth. • Gap section not registering. <p>Engine Wiring Harness Related</p> <ul style="list-style-type: none"> • Pin circuit wiring or connectors. • Pin(s) 3 and/or 21 for "35 Pin" (MA 1.7) Metal-Cased ECU. • Pin(s) 9 and/or 10 for "24 Pin" (MSE 1.0) Plastic-Cased ECU. • Pin(s) 9 and/or 10 for "32 Pin" (MSE 1.1) Plastic-Cased ECU. <p>ECU/Harness Related</p> <ul style="list-style-type: none"> • ECU-to-harness connection problem.

Code 31

Component:	Fuel Mixture or Oxygen Sensor
Fault:	System too lean. Oxygen sensor not sending expected voltage to ECU.
Condition:	System operates under “open loop” control only. Until fault is detected and registered by ECU, engine will run rich if oxygen sensor is shorted to ground or lean if it is shorted to battery voltage. After fault is detected, performance can vary, depending on cause. If performance is pretty good, problem is probably with the oxygen sensor, wiring, or connectors. If engine is still running rich (laboring, short on power) or lean (popping or misfiring), fuel mixture is suspect, probably incorrect TPS initialization or low fuel pressure.
Conclusion:	<p>TPS Initialization Incorrect</p> <ul style="list-style-type: none"> Lean condition (check oxygen sensor signal with VOA and see Oxygen Sensor section). <p>Engine Wiring Harness Related</p> <ul style="list-style-type: none"> Pin circuit wiring or connectors. <ul style="list-style-type: none"> Pin 10 for “35 Pin” (MA 1.7) Metal-Cased ECU. Pin 11 for “24 Pin” (MSE 1.0) Plastic-Cased ECU. Pin 20 for “32 Pin” (MSE 1.1) Plastic-Cased ECU. <p>Low Fuel Pressure</p> <p>Oxygen Sensor Related</p> <ul style="list-style-type: none"> Sensor connector or wiring problem. Exhaust leak. Poor ground path to engine (sensor is case grounded). <p>Poor system ground from ECU to engine, causing rich running while indicating lean.</p>

Code 32

Component:	Oxygen Sensor
Fault:	No change in sensor output signal.
Condition:	Open loop operation only, may cause a drop in system performance and fuel efficiency.
Conclusion:	<p>Engine Wiring Harness Related</p> <ul style="list-style-type: none"> Pin circuit wiring or connectors. <ul style="list-style-type: none"> Pin 10 for “35 Pin” (MA 1.7) Metal-Cased ECU. Pin 11 for “24 Pin” (MSE 1.0) Plastic-Cased ECU. Pin 20 for “32 Pin” (MSE 1.1) Plastic-Cased ECU. <p>Oxygen Sensor Related</p> <ul style="list-style-type: none"> Sensor connector or wiring problem. Sensor contaminated or damaged. Sensor below minimum operating temperature (375°C, 709°F). Poor ground path from sensor to engine (sensor grounds through shell, see Oxygen Sensor section).

EFI SYSTEM-BOSCH

Code 33

Component:	Oxygen Sensor/Fuel System
Fault:	System too rich. Temporary fuel adaptation control is at upper limit.
Condition:	<p>Fuel Supply Related (nothing lean-only rich)</p> <ul style="list-style-type: none"> ● Restricted return line causing excessive fuel pressure. ● Fuel inlet screen plugged (in-tank fuel pump only). ● Incorrect fuel pressure at fuel rail. <p>Oxygen Sensor Related</p> <ul style="list-style-type: none"> ● Sensor connector or wiring problem. ● Sensor contaminated or damaged. ● Exhaust leak. ● Poor ground path. ● Pin circuit wiring or connectors. <ul style="list-style-type: none"> Pin 10 for “35 Pin” (MA 1.7) Metal-Cased ECU. Pin 11 for “24 Pin” (MSE 1.0) Plastic-Cased ECU. Pin 20 for “32 Pin” (MSE 1.1) Plastic-Cased ECU. <p>TPS Sensor Related</p> <ul style="list-style-type: none"> ● Throttle plate position incorrectly set or registered during Initialization. ● TPS problem or malfunction. <p>Engine Wiring Harness Related</p> <ul style="list-style-type: none"> ● Difference in voltage between sensed voltage (pin circuit 17 for metal-cased ECU, pin circuit 2 for plastic-cased ECU) and actual injector voltage (circuit 45/45A). <p>Systems Related</p> <ul style="list-style-type: none"> ● Ignition (spark plug, plug wire, ignition coil). ● Fuel (fuel type/quality, injector, fuel pump, fuel pressure). ● Combustion air (air cleaner dirty/restricted, intake leak, throttle bores). ● Base engine problem (rings, valves). ● Exhaust system leak. ● Fuel in crankcase oil. ● Blocked or restricted fuel return circuit to tank. <p>ECU/Harness Related</p> <ul style="list-style-type: none"> ● ECU-to-harness connection problem.

Code 34

Component:	Oxygen Sensor/Fuel System Components
Fault:	Long term fuel adaptation control is at upper or lower limit.
Condition:	System operates closed loop. No appreciable performance loss as long as temporary adaptation can provide sufficient compensation.
Conclusion:	<p>Oxygen Sensor Related</p> <ul style="list-style-type: none"> ● Sensor connector or wiring problem. ● Sensor contaminated or damaged. ● Exhaust leak. ● Poor ground path. ● Pin circuit wiring or connectors. <ul style="list-style-type: none"> Pin 10 for “35 Pin” (MA 1.7) Metal-Cased ECU. Pin 11 for “24 Pin” (MSE 1.0) Plastic-Cased ECU. Pin 20 for “32 Pin” (MSE 1.1) Plastic-Cased ECU. <p>TPS Sensor Related</p> <ul style="list-style-type: none"> ● Throttle plate position incorrect during Initialization procedure. ● TPS problem or malfunction. <p>Engine Wiring Harness Related</p> <ul style="list-style-type: none"> ● Difference in voltage between sensed voltage (pin circuit 17 for metal-cased ECU, pin circuit 2 for plastic-cased ECU) and actual injector voltage (circuit 45/45A). ● Problem in wiring harness. ● ECU-to-harness connection problem. <p>Systems Related</p> <ul style="list-style-type: none"> ● Ignition (spark plug, plug wire, ignition coil). ● Fuel (fuel type/quality, injector, fuel pressure, fuel pump). ● Combustion air (air cleaner dirty/restricted, intake leak, throttle bores). ● Base engine problem (rings, valves). ● Exhaust system leak (muffler, flange, oxygen sensor mounting boss, etc.). ● Fuel in crankcase oil. ● Altitude. ● Blocked or restricted fuel return circuit to tank.

Code 42

Component:	Engine (Oil) Temperature Sensor
Fault:	Not sending proper signal to ECU.
Condition:	Engine may be hard to start because ECU can't determine correct fuel mixture.
Conclusion:	<p>Temperature Sensor Related.</p> <ul style="list-style-type: none"> ● Sensor wiring or connection. <p>Engine Wiring Harness Related "35 Pin" (MA 1.7) Metal-Cased ECU:</p> <ul style="list-style-type: none"> ● Pin circuits 14 and/or 27A damaged (wires, connectors) or routed near noisy signal (coils, alternator, etc.). ● ECU-to-harness connection problem. <p>Engine Wiring Harness Related "24 Pin" (MSE 1.0) Plastic-Cased ECU:</p> <ul style="list-style-type: none"> ● Pin circuits 4, 6 and/or 4A damaged (wires, connectors) or routed near noisy signal (coils, alternator, etc.). ● ECU-to-harness connection problem. <p>Engine Wiring Harness Related "32 Pin" (MSE 1.1) Plastic-Cased ECU:</p> <ul style="list-style-type: none"> ● Pin circuits 4, 6 and/or (4A) damaged (wires, connectors) or routed near noisy signal (coils, alternator, etc.). ● ECU-to-harness connection problem. <p>System Related</p> <ul style="list-style-type: none"> ● Engine is operating above 176°C (350°F) temperature sensor limit.

Code 43 and 44 "32 Pin" (MSE 1.1) Plastic-Cased ECU only.

Component:	TPS "Auto-Learn" initialization function failed, throttle angle out of learning range.
Fault:	While performing TPS "Auto-Learn" function, measured throttle angle was not within acceptable limits.
Condition:	MIL illuminated. Engine will continue to run but not properly. Upon restart TPS Auto-Learn function will run again unless voltage to ECU disconnected to clear memory.
Conclusion:	<p>TPS Related</p> <ul style="list-style-type: none"> ● TPS rotated on throttle shaft assembly beyond allowable range. ● TPS bad. <p>Engine Wiring Harness Related</p> <ul style="list-style-type: none"> ● Broken or shorted wire in harness. <ul style="list-style-type: none"> ECU pin 18 to TPS pin 1. ECU pin 4 to TPS pin 2. ECU pin 8 to TPS pin 3. <p>Throttle Body Related</p> <ul style="list-style-type: none"> ● Throttle shaft inside TPS worn, broken, or damaged. ● Throttle plate loose or misaligned. ● Throttle plate bent or damaged allowing extra airflow past, or restricting movement. <p>ECU Related</p> <ul style="list-style-type: none"> ● Circuit providing voltage or ground to TPS damaged. ● TPS signal input circuit damaged.

EFI SYSTEM-BOSCH

Code 51 "32 Pin" (MSE 1.1) Plastic-Cased ECU only.

Component:	Injector #1 circuit open, shorted to ground, or shorted to battery.
Fault:	Injector #1 is not functioning because the circuit is open, shorted to ground, or shorted to battery.
Condition:	Engine will run very poorly with only one cylinder functioning.
Conclusion:	<p>Injector Related</p> <ul style="list-style-type: none"> • Injector coil shorted or opened. <p>Engine Wiring Harness Related</p> <ul style="list-style-type: none"> • Broken or shorted wire in harness. ECU pin 14 to injector pin 2. ECU pin 28 to fuel pump relay pin 86. Note: after key-off then key-on code 56 would be set also. Fuel pump relay pin 87 to injector pin 1. • Open main fuse F1. <p>Fuel Pump Relay Related</p> <ul style="list-style-type: none"> • Bad fuel pump relay. Primary side functional but pin 30 to pin 87 remains open. Primary side pin 85 to pin 86 is either open, or shorted during engine operation. Note: after key-off then key-on code 56 would be set also. <p>ECU Related</p> <ul style="list-style-type: none"> • Circuit controlling injector #1 damaged. • Circuit controlling fuel pump relay damaged.

Code 52 "32 Pin" (MSE 1.1) Plastic-Cased ECU only.

Component:	Injector #2 circuit open, shorted to ground, or shorted to battery.
Fault:	Injector #2 is not functioning because circuit is open, shorted to ground, or shorted to battery.
Condition:	Engine will run very poorly with only one cylinder functioning.
Conclusion:	<p>Injector Related</p> <ul style="list-style-type: none"> • Injector coil shorted or opened. <p>Engine Wiring Harness Related</p> <ul style="list-style-type: none"> • Broken or shorted wire in harness. ECU pin 15 to injector pin 2. ECU pin 28 to fuel pump relay pin 86. Note: after key-off then key-on code 56 would be set also. Fuel pump relay pin 87 to injector pin 1. • Opened main fuse F1. <p>Fuel Pump Relay Related</p> <ul style="list-style-type: none"> • Bad fuel pump relay. Primary side functional, but pin 30 to pin 87 remains open. Primary side pin 85 to pin 86 is open or shorted during engine operation. Note: after key-off then key-on code 56 would be set also. <p>ECU Related</p> <ul style="list-style-type: none"> • Circuit controlling injector #2 damaged. • Circuit controlling fuel pump relay damaged.

Code 55 "32 Pin" (MSE 1.1) Plastic-Cased ECU only.

Component:	MIL (Diagnostic lamp) circuit open, shorted to ground, or shorted to battery.
Fault:	MIL is not functioning because circuit is open, shorted to ground, or shorted to battery.
Condition:	Engine will run normally if no other errors are present.
Conclusion:	<p>MIL (diagnostic lamp) Related</p> <ul style="list-style-type: none"> • MIL element opened or element shorted to ground. • Lamp missing. <p>Engine Wiring Harness Related</p> <ul style="list-style-type: none"> • Broken or shorted wire in harness. ECU pin 29 to lamp open or shorted. <p>Vehicle Wiring Harness Related</p> <ul style="list-style-type: none"> • Broken or shorted wire in harness. Power lead to MIL open or shorted. <p>ECU Related</p> <ul style="list-style-type: none"> • Circuit controlling lamp damaged.

Code 56 "32 Pin" (MSE 1.1) Plastic-Cased ECU only.

Component:	Fuel pump relay circuit open, shorted to ground, or shorted to battery.
Fault:	Fuel pump, ignition coils, and fuel injectors will not function because fuel pump relay circuit is either open, shorted to ground, or may be "on" continuously if shorted to battery.
Condition:	Engine will not run, or fuel pump will continue to run when switch is off.
Conclusion:	<p>Fuel Pump Relay Related</p> <ul style="list-style-type: none"> Bad fuel pump relay. Primary side open or shorted. <p>Fuel Pump Related</p> <ul style="list-style-type: none"> Fuel pump open or shorted internally. <p>Engine Wiring Harness Related</p> <ul style="list-style-type: none"> Fuel pump fuse F1 open. Broken or shorted wire in harness. ECU pin 28 to fuel pump relay pin 86. Ignition switch to fuel pump relay pin 85. <p>ECU Related</p> <ul style="list-style-type: none"> Circuit controlling fuel pump relay damaged.

Code 61

Component:	
Fault:	
Condition:	Denotes end of fault codes. If signaled first, no other fault codes are present.
Conclusion:	

Troubleshooting Flow Chart

Flow chart provides an alternative method of troubleshooting EFI system. Chart will enable you to review entire system in about 10-15 minutes. Using chart, accompanying diagnostic aids (listed after chart), and any signaled fault codes, you should be able to quickly locate any problems within system.

Flow Chart Diagnostic Aids

Diagnostic Aid #1 "system power" (MIL does not illuminate when key is turned ON).

NOTE: MIL in Metal-Cased ECU systems is an LED.
MIL in Plastic-Cased ECU systems must be a 1/4 watt incandescent lamp.

Possible causes:

- Battery
- Main system fuse
- MIL light bulb burned out
- MIL electrical circuit problem
"35 Pin" (MA 1.7) Metal-Cased ECU: Pin circuits 31 and 31A.
"24 Pin" (MSE 1.0) Plastic-Cased ECU: Pin circuits 19 and 84.

"32 Pin" (MSE 1.1) Plastic-Cased ECU: Pin circuits 29 and 84.

- Ignition switch
- Permanent ECU power circuit problem
"35 Pin" (MA 1.7) Metal-Cased ECU: Pin circuit 16.
"24 Pin" (MSE 1.0) Plastic-Cased ECU: Pin circuit 1.
"32 Pin" (MSE 1.1) Plastic-Cased ECU: Pin circuit 1.
- Switched ECU power circuit problem
"35 Pin" (MA 1.7) Metal-Cased ECU: Pin circuit 17.
"24 Pin" (MSE 1.0) Plastic-Cased ECU: Pin circuit 2.
"32 Pin" (MSE 1.1) Plastic-Cased ECU: Pin circuit 2.
- ECU grounds
- ECU

Diagnostic Aid #2 "FAULT CODES" (Refer to detailed fault code listing before flow chart and servicing information for respective components)

- Code 21-Engine Speed Synchronization
- Code 22-Throttle Position Sensor (TPS)
- Code 23-Engine Control Unit (ECU)
- Code 31-Oxygen Sensor
- Code 32-Oxygen Sensor
- Code 33-Fuel System (temporary adaptation factor)
- Code 34-Fuel System (permanent adaptation factor)
- Code 42-Engine (Oil) Temperature Sensor
- Code 43-TPS "Auto-Learn" Initialization Function (Below Min. Limit), **"32 Pin" (MSE 1.1) Plastic-Cased ECU only.**
- Code 44-TPS "Auto-Learn" Initialization Function (Above Max. Limit), **"32 Pin" (MSE 1.1) Plastic-Cased ECU only.**
- Code 51-Injector 1, **"32 Pin" (MSE 1.1) Plastic-Cased ECU only.**
- Code 52-Injector 2, **"32 Pin" (MSE 1.1) Plastic-Cased ECU only.**
- Code 55-MIL Light, **"32 Pin" (MSE 1.1) Plastic-Cased ECU only.**
- Code 56-Pump Relay, **"32 Pin" (MSE 1.1) Plastic-Cased ECU only.**
- Code 61-End of Fault/Blink Code Transmission.

Diagnostic Aid #3 "RUN/ON" (MIL remains "on" while engine is running)*

Possible causes:

- Fault codes which turn on MIL when engine is running.
 - Code 21-Engine Speed Synchronization
 - Code 22-Throttle Position Sensor (TPS)
 - Code 23-Engine Control Unit (ECU)
 - Code 31-Oxygen Sensor (shorted)
 - Code 34-Fuel System (permanent adaptation at limit)
 - Code 42-Engine (Oil) Temperature Sensor
 - Code 43-TPS "Auto-Learn" Initialization Function (Below Min. Limit), **"32 Pin" (MSE 1.1) Plastic-Cased ECU only.**
 - Code 44-TPS "Auto-Learn" Initialization Function (Above Max. Limit) **"32 Pin" (MSE 1.1) Plastic-Cased ECU only.**

EFI SYSTEM-BOSCH

- Code 51-Injector 1, **"32 Pin" (MSE 1.1) Plastic-Cased ECU only.**
- Code 52-Injector 2, **"32 Pin" (MSE 1.1) Plastic-Cased ECU only.**
- Code 55-MIL Light, **"32 Pin" (MSE 1.1) Plastic-Cased ECU only.**
- Code 56-Pump Relay, **"32 Pin" (MSE 1.1) Plastic-Cased ECU only.**
- MIL circuit grounded between light and ECU.
"35 Pin" (MA 1.7) Metal-Cased ECU: Pin circuit 31.
"24 Pin" (MSE 1.0) Plastic-Cased ECU: Pin circuit 19.
"32 Pin" (MSE 1.1) Plastic-Cased ECU: Pin circuit 29.
- ECU

Diagnostic Aid #4 SPEED SENSOR (MIL does not turn off during cranking). Indicates ECU is not receiving a signal from speed sensor.

Possible causes:

- Speed sensor
- Speed sensor circuit problem
"35 Pin" (MA 1.7) Metal-Cased ECU: Pin circuits 3 and 21.
"24 Pin" (MSE 1.0) Plastic-Cased ECU: Pin circuits 9 and 10.
"32 Pin" (MSE 1.1) Plastic-Cased ECU: Pin circuits 9 and 10.
- Speed sensor/toothed wheel air gap
- Toothed wheel
- Flywheel key sheared
- ECU

Diagnostic Aid #5 "FUEL PUMP" (fuel pump not turning on)

Possible causes:

- Fuel pump fuse
- Fuel pump circuit problem
"35 Pin" (MA 1.7) Metal-Cased ECU: Circuits 43, 44, and relay.
"24 Pin" (MSE 1.0) Plastic-Cased ECU: Circuits 30, 87, and relay.
"32 Pin" (MSE 1.1) Plastic-Cased ECU: Circuits 30, 87, and relay.
- Fuel pump

Diagnostic Aid #6 "RELAY" (relay not operating)

Possible causes:

- Safety switches/circuit(s) problem
"35 Pin" (MA 1.7) Metal-Cased ECU: Circuits 41 and 41A.
"24 Pin" (MSE 1.0) Plastic-Cased ECU: Circuit 3.
"32 Pin" (MSE 1.1) Plastic-Cased ECU: Circuit 25.
- Relay circuit(s) problem
"35 Pin" (MA 1.7) Metal-Cased ECU: Circuits 28, 41, and 41A.
"24 Pin" (MSE 1.0) Plastic-Cased ECU: Circuits 18, 85, 30, and 87.

"32 Pin" (MSE 1.1) Plastic-Cased ECU: Circuits 28,85, 30, and 87.

- Relay
- ECU grounds
- ECU

Diagnostic Aid #7 "IGNITION SYSTEM" (no spark)

Possible causes:

- Spark plug
- Plug wire
- Coil
- Coil circuit(s)
"35 Pin" (MA 1.7) Metal-Cased ECU: Circuits 1, 19, 40, 40A, 43, and relay.
"24 Pin" (MSE 1.0) Plastic-Cased ECU: Circuits 22, 23, 65, 66, 30, and relay.
"32 Pin" (MSE 1.1) Plastic-Cased ECU: Circuits 30, 31, 65, 66, relay and relay circuit 30.
- ECU grounds
- ECU

Diagnostic Aid #8 "FUEL SYSTEM-ELECTRICAL" (no fuel delivery)

Possible causes:

- No fuel
- Air in fuel rail
- Fuel valve shut off
- Fuel filter/line plugged
- Injector circuit(s)
"35 Pin" (MA 1.7) Metal-Cased ECU: Circuits 35, 35A, 45, and 45A.
"24 Pin" (MSE 1.0) Plastic-Cased ECU: Circuits 16, 17, 45, and 45A.
"32 Pin" (MSE 1.1) Plastic-Cased ECU: Circuits 14,15, and 45.
- Injector
- ECU grounds
- ECU

Diagnostic Aid #9 "FUEL SYSTEM" (fuel pressure)

Possible causes for low fuel system pressure:

- Low fuel
- Fuel filter plugged
- Fuel supply line plugged
- Fuel pump

Possible causes for high fuel system pressure:

- Pressure regulator
- Fuel return line plugged or restricted.

Diagnostic Aid #10 "BASIC ENGINE" (cranks but will not run)

Possible causes:

- Refer to basic engine troubleshooting charts within Troubleshooting, Electronic Fuel Injection-ECH EFI, and Electrical Systems.

Bosch EFI Diagnostic Flow Diagram

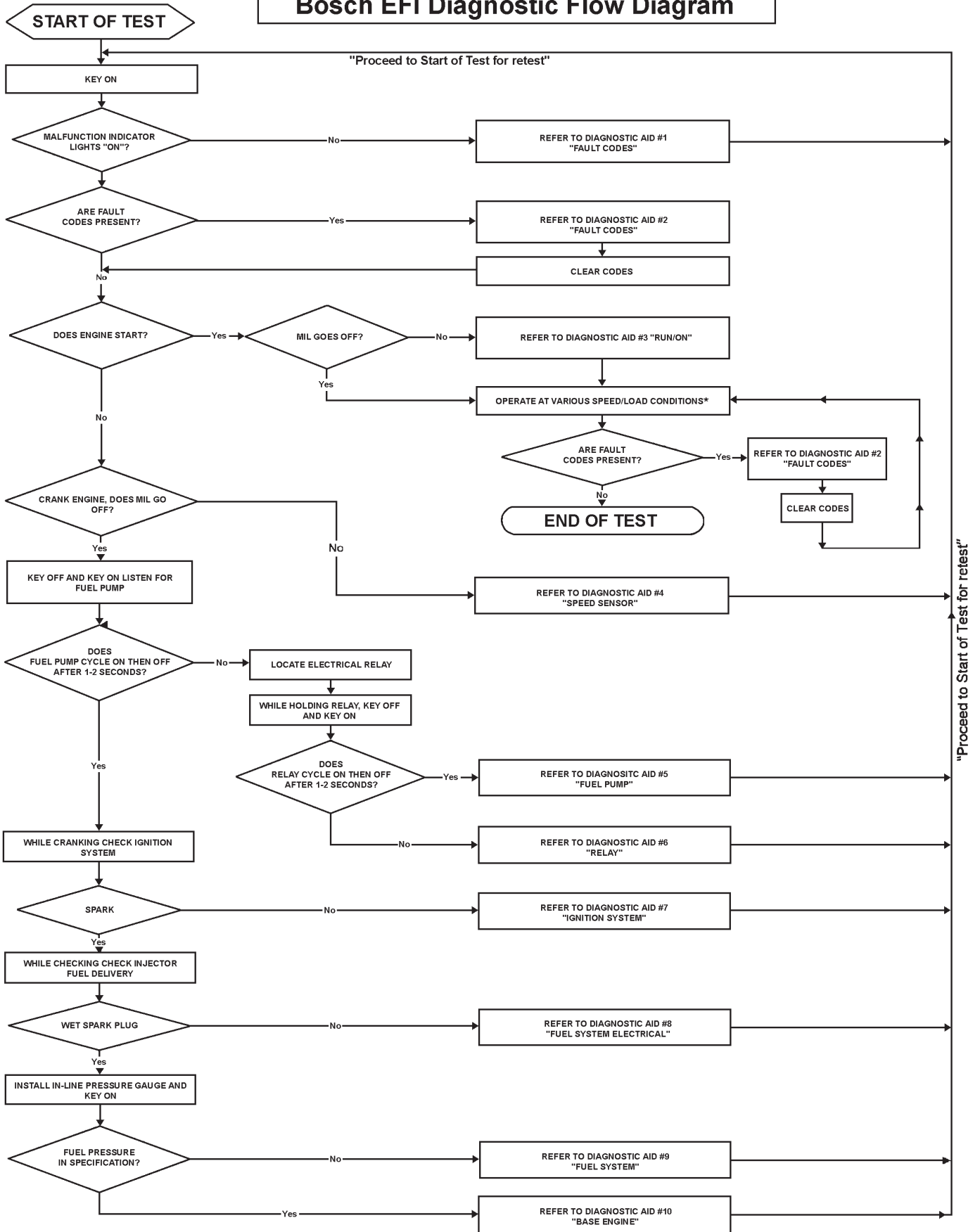

Lubrication System

This engine uses a full pressure lubrication system which delivers oil under pressure to crankshaft, camshaft, connecting rod bearing surfaces, and hydraulic valve lifters.

A high-efficiency gerotor oil pump maintains high oil flow and oil pressure, even at low speeds and high operating temperatures. A pressure relief valve limits maximum pressure of system. Closure plate must be removed to service oil pickup, pressure relief valve, and oil pump.

Lubrication Components

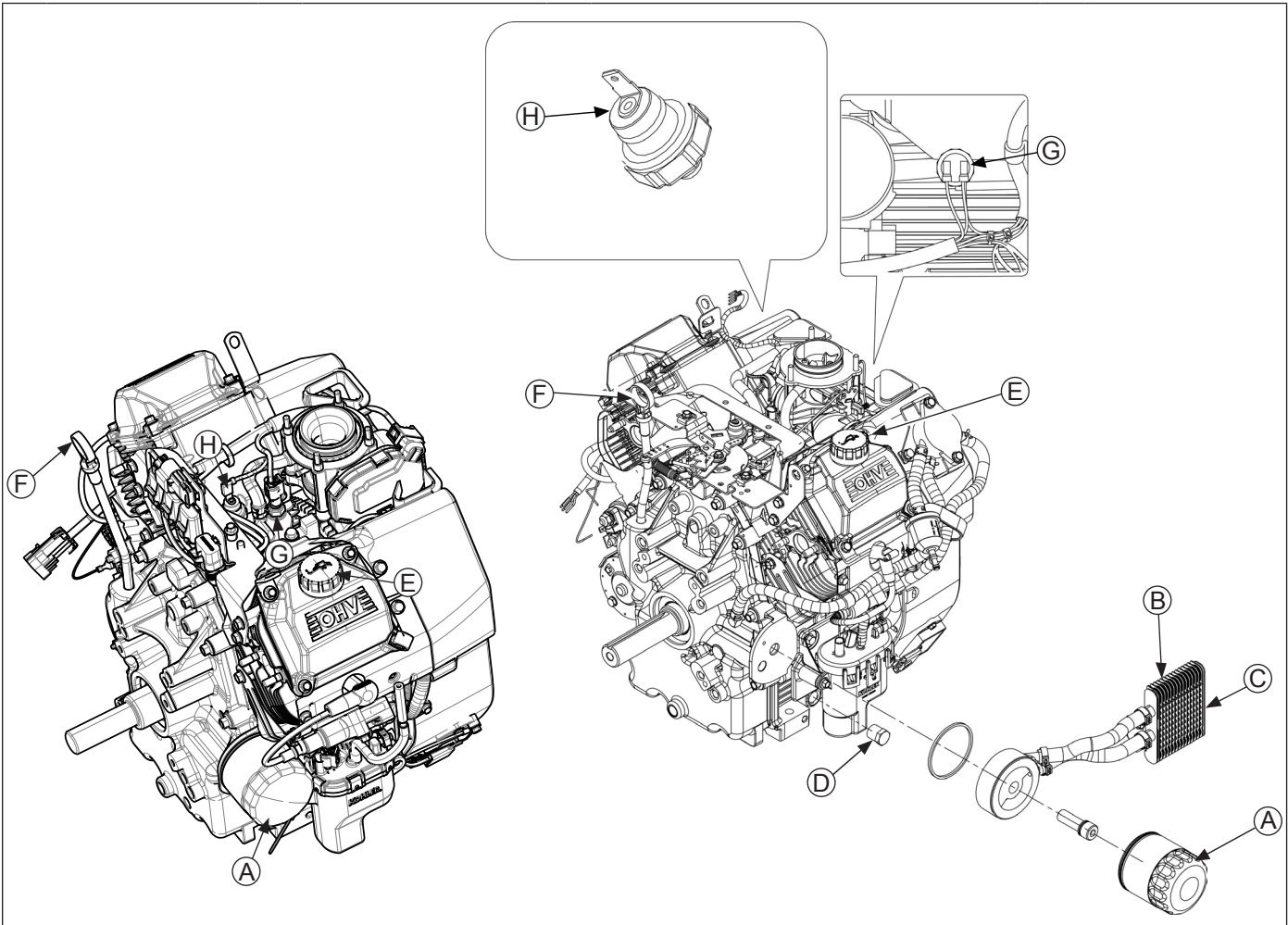

A	Oil Filter	B	Back Side	C	Oil Cooler	D	Oil Drain Plug	E	Oil Fill Cap
F	Oil Fill/Dipstick	G	Engine Temperature Sensor	H	Oil Sentry™				

OIL RECOMMENDATIONS

Refer to Maintenance.

CHECK OIL LEVEL

NOTE: To prevent extensive engine wear or damage, never run engine with oil level below or above operating range indicator on dipstick.

Ensure engine is cool. Clean oil fill/dipstick areas of any debris.

1. Remove dipstick; wipe oil off.
 - a. Push-on cap: reinsert dipstick into tube; press completely down.
or
 - b. Threaded cap: reinsert dipstick into tube; rest cap on tube, do not thread cap onto tube.
2. Remove dipstick; check oil level. Level should be at top of indicator on dipstick.
3. If oil is low on indicator, add oil up to top of indicator mark.
4. Reinstall and secure dipstick.

CHANGE OIL AND FILTER

Change oil while engine is warm.

1. Clean area around oil fill cap/dipstick and drain plug. Remove drain plug and oil fill cap/dipstick. Allow oil to drain completely.
2. Clean area around oil filter. Place a container under filter to catch any oil and remove filter. Wipe off mounting surface. Reinstall drain plug. Torque to 10 ft. lb. (13.6 N·m).
3. Place new filter in shallow pan with open end up. Fill with new oil until oil reaches bottom of threads. Allow 2 minutes for oil to be absorbed by filter material.
4. Apply a thin film of clean oil to rubber gasket on new filter.
5. Refer to instructions on oil filter for proper installation.
6. Fill crankcase with new oil. Level should be at top of indicator on dipstick.
7. Reinstall oil fill cap/dipstick and tighten securely.
8. Start engine; check for oil leaks. Stop engine; correct leaks. Recheck oil level.
9. Dispose of used oil and filter in accordance with local ordinances.

OIL COOLER (if equipped)

1. Clean fins with a brush or compressed air.
2. Remove screws securing oil cooler and tilt to clean back side.
3. Reinstall oil cooler and torque to 2.2 N·m (20 in. lb.).

OIL SENTRY™ (if equipped)

This switch is designed to prevent engine from starting in a low oil or no oil condition. Oil Sentry™ may not shut down a running engine before damage occurs. In some applications this switch may activate a warning signal. Read your equipment manuals for more information.

Oil Sentry™ pressure switch is installed in breather cover. On engines not equipped with Oil Sentry™ installation hole is sealed with a 1/8-27 N.P.T.F. pipe plug.

Installation

1. Apply pipe sealant with Teflon® (Loctite® PST® 592™ Thread Sealant or equivalent) to threads of switch.
2. Install switch into tapped hole in breather cover.
3. Torque switch to 4.5 N·m (40 in. lb.).

Testing

Compressed air, a pressure regulator, pressure gauge, and a continuity tester are required to test switch.

ECH Models:

Normally Closed Switch

1. Connect continuity tester across blade terminal and metal case of switch. With 0 psi pressure applied to switch, tester should indicate continuity (switch closed).
2. Gradually increase pressure to switch. As pressure increases through range of 2.0/5.0 psi, tester should indicate a change to no continuity (switch open). Switch should remain open as pressure is increased to 90 psi maximum.
3. Gradually decrease pressure through range of 2.0/5.0 psi. Tester should indicate a change to continuity (switch closed) down to 0 psi.
4. Replace switch if it does not operate as specified.

Normally Open Switch

1. Connect continuity tester across blade terminal and metal case of switch. With 0 psi pressure applied to switch, tester should indicate no continuity (switch open).
2. Gradually increase pressure to switch. As pressure increases through range of 2.0/5.0 psi, tester should indicate a change to continuity (switch closed). Switch should remain closed as pressure is increased to 90 psi maximum.
3. Gradually decrease pressure through range of 2.0/5.0 psi. Tester should indicate a change to no continuity (switch open) down to 0 psi.

CH Models:

Pressure Switch	PSI
12 099 04	2-6
24 099 03	2-5
25 099 27	2-5
28 099 01	2-6
48 099 07	12-16
52 099 08	7-11
52 099 09	7-11

Electrical System

BATTERY CHARGING SYSTEM

	⚠ CAUTION
Electrical Shock can cause injury. Do not touch wires while engine is running.	

NOTE: Observe following guidelines to avoid damage to electrical system and components:

- Make sure battery polarity is correct. A negative (-) ground system is used.
- Inspect charging system fuse. If damaged, replace before continuing.

- Disconnect rectifier-regulator plug (20/25 amp) or ring terminals (optional high output) and/or wiring harness plug before doing any electric welding on equipment powered by engine. Also, disconnect all other electrical accessories in common ground with engine.

- Prevent stator (AC) leads from touching or shorting while engine is running. This could damage stator.

These engines are equipped with a 20/25 amp regulated charging system (refer to pages 150-152) or an optional high output 40/50 amp charging system (refer to pages 153-154).

20/25 Amp Regulated Charging System

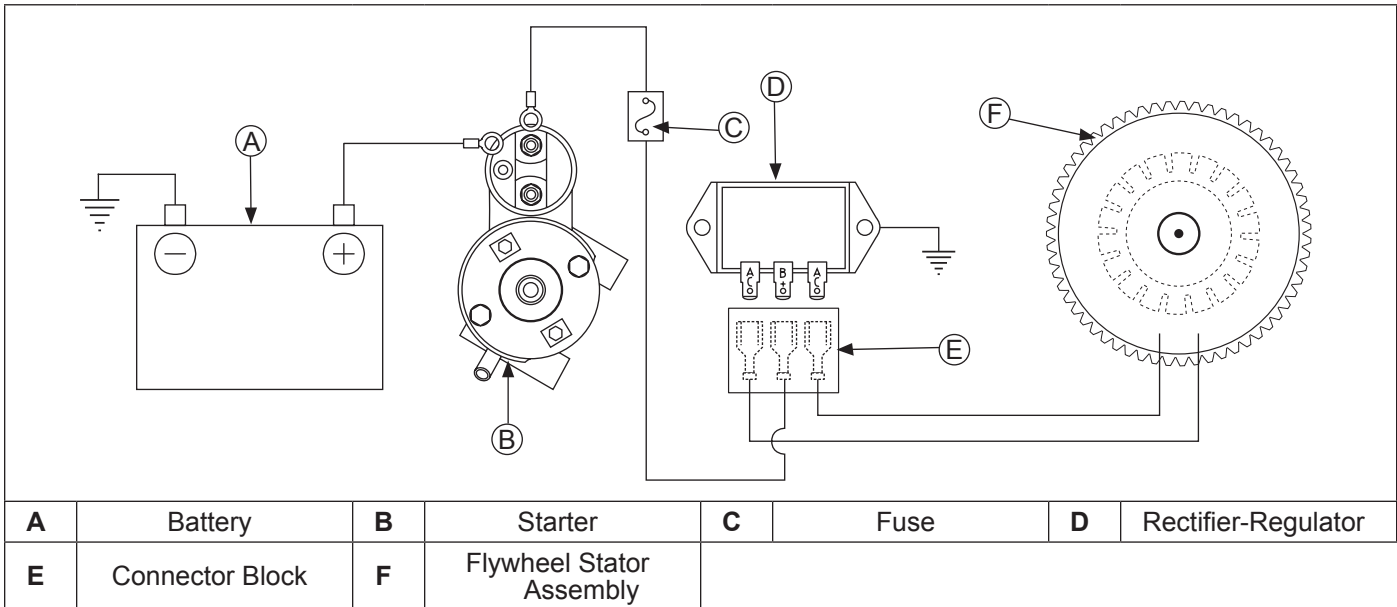

Stator

Stator is mounted on crankcase behind flywheel. Follow procedures in Disassembly/Inspection and Service and Reassembly if stator replacement is necessary.

Rectifier-Regulator

NOTE: When installing rectifier-regulator, take note of terminal markings and install plug(s) accordingly.

NOTE: Disconnect all electrical connections attached to rectifier-regulator. Testing may be performed with rectifier-regulator mounted or loose. Repeat applicable test procedure 2 or 3 times to determine condition of part.

Rectifier-regulator is mounted on blower housing. To replace, disconnect plug(s), remove mounting screws, and ground wire or metal grounding strap.

Testing rectifier-regulator may be performed as follows, using appropriate rectifier-regulator tester.

To test 20/25 amp rectifier-regulators:

1. Connect tester ground lead (with spring clamp) to body of rectifier-regulator.
2. Connect red lead from tester to middle terminal labeled B+.
3. Connect black leads from tester to both outer AC terminals on rectifier-regulator.
4. Plug tester into proper AC outlet/power for tester being used. Turn on power switch. POWER light should be illuminated and one of four status lights may be lit as well. This does not represent condition of part.
5. Press TEST button until a click is heard and then release. Momentarily one of four status lights will illuminate indicating partial condition of part.

Condition	Conclusion
	20/25 amp
OK (green) light comes on and stays steady.	Disconnect tester black lead attached to 1 AC terminal and reconnect it to other AC terminal. Repeat test. If OK (green) light comes on again, part is good and may be used.
NOTE: A flashing LOW light can also occur as a result of an inadequate ground lead connection. Make certain connection location is clean and clamp is secure. Other lights come on.	Rectifier-regulator is faulty and should not be used.

Troubleshooting Guide

20/25 Amp Battery Charging System

NOTE: Always zero digital volt-ohm meter (DVOM) on each scale before testing to ensure accurate readings. Voltage test should be made with engine running at specific test condition noted. Battery should be checked for state of charge (non-operating voltage 12.5 VDC or lower, battery should be charged or replaced).

When problems occur in keeping a battery fully charged or a battery charges at a high rate, battery or charging system may be at fault. Before performing any testing, battery must be fully charged.

To test charging system:

1. Inspect charging system fuse. If damaged, replace before continuing.
2. Visually inspect system components and wiring. Look for damaged or loose wire connections, including battery cables.
3. Set DVOM to DC volts, place red (positive) lead of tester on rectifier-regulator body and black (negative) lead to battery negative (-) terminal. Run engine and observe volt reading on meter. If voltage is 0.5 VDC or less, continue with testing. If voltage is higher than 0.5 VDC, inspect and repair wiring/connections as needed (insufficient ground).
4. Perform these output tests for charging system using DVOM set to DC volts.
 - a. With engine off and key switch in OFF position, measure voltage at battery. If less than 12.4 VDC, recharge battery and retest. If 12.5 VDC continue with tests.
 - b. Run engine at high speed no electrical or mechanical load (greater than 3000 RPM). After running 1 minute, measure voltage at battery.
 - i. If voltage increases to between 13-15 VDC, system is working correctly.
 - ii. If voltage increases to 15.5 VDC or higher, system is overcharging. Replace rectifier-regulator.
 - iii. If voltage stays at 12.5 VDC or decreases, charging system is NOT operating, proceed to step 5.
5. With engine off, unplug rectifier-regulator connector and inspect connector terminals within connector body and rectifier-regulator terminals for corrosion/ arcing/damage. Repair/replace as needed. If OK, proceed to next test.

6. Set DVOM to AC volts, place test leads to each white stator wire. Run engine at 1200 RPM or greater and monitor voltage.

Condition	Conclusion
Voltage is 13 volts AC or more.	Stator is OK.
Voltage is less than 13 volts AC.	Stator is faulty. Continue with steps 7 and 8).

7. With engine off and stator unplugged from rectifier-regulator, check for resistance/continuity between across stator leads (white wires).

Condition	Conclusion
Resistance is 0.1/0.2 ohms.	Stator coil is OK.
Resistance is 0 ohms.	Stator is shorted; replace.
Resistance is infinity ohms/no continuity.	Stator is open; replace.

8. With engine off and stator unplugged from rectifier-regulator, check for resistance/continuity from stator leads (white wires) to ground.

Condition	Conclusion
Resistance is infinity ohms (no continuity).	Stator is OK (not shorted to ground).
Resistance (or continuity) measured.	Stator leads are shorted to ground; replace.

9. If stator tests good (steps 5-8), but system was identified in step 3 as not working, failure is likely with rectifier-regulator. Replace rectifier-regulator, retest system to confirm repairs (step 4).

Electrical System

FUSES

This engine has 3 blade type automotive fuses. Replacement fuses must have same rating as blown fuse. Use fuse chart below to determine correct fuse.

Wire Color	Fuse Rating
2 Purple Wires	30-amp Fuse
1 Red Wire w/Black Stripe 1 Red Wire w/White Stripe	10-amp Fuse
2 Red Wires	10-amp Fuse

Fuse Replacement

1. Shut engine off and remove key.
2. Locate fuse holders.
3. Remove fuse cover and pull out fuse. Inspect condition of fuse.
4. Inspect fuse for a solid fusible link or a broken fusible link. Replace fuse if fusible link is broken. If you are not sure if fusible link is broken, replace fuse.
5. Insert fuse into fuse holder until it is seated properly. Install fuse cover.
6. If replacement fuse fails, there is a problem within circuit. Diagnostics are required. Identify which circuit is affected (see EFI System for electrical schematic) by identifying failed fuse/circuit. Perform troubleshooting procedures appropriate for circuit fuse that failed.
7. Install fuse holder into fuse cover.

40/50 Amp High Output Regulated Charging System

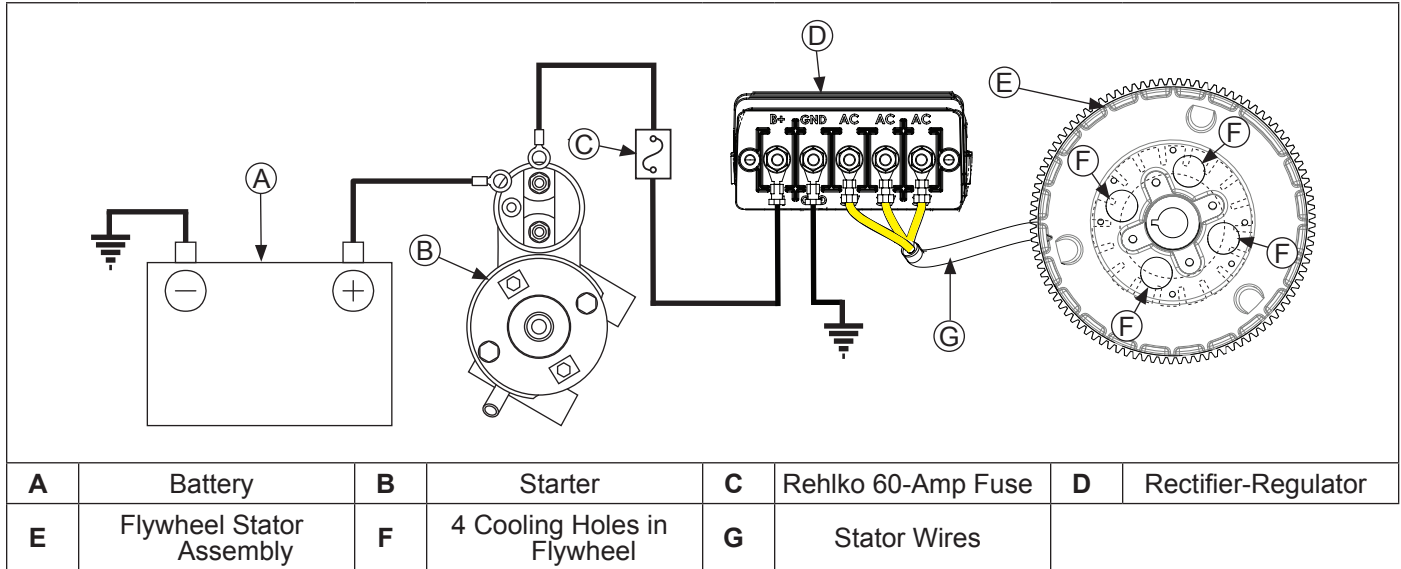

Stator

Stator is mounted on crankcase behind flywheel. Follow procedures in Disassembly/Inspection and Service and Reassembly if stator replacement is necessary.

Rectifier-Regulator

NOTE: When installing rectifier-regulator, take note of terminal markings and install ring terminals accordingly.

Rectifier-regulator is mounted on a bracket on top of engine or OEM installed in application. Follow procedures in Disassembly/Inspection and Service and Reassembly or refer to your equipment manual if rectifier-regulator replacement is necessary.

High Output Charging Wiring Harness

In addition to main engine wiring harness (with 3 blade type automotive fuses), engines equipped with a high output charging system will have a separate charging wiring harness with one (1) 60-amp large blade type automotive type fuse. However, 30-amp fuse in main engine wiring harness is then nonfunctional. Purple charge wire ring terminals in main engine wiring harness are completely sealed and retained using a special heat shrink cap for non use. No service is required for this circuit.

Troubleshooting Guide

40/50 Amp High Output Battery Charging System

NOTE: Always zero digital volt-ohm meter (DVOM) on each scale before testing to ensure accurate readings. Voltage test should be made with engine running at specific test condition noted. Battery should be checked for state of charge (non-operating voltage 12.5 VDC or lower, battery should be charged or replaced).

When problems occur in keeping a battery fully charged or a battery charges at a high rate, battery or charging system may be at fault. Before performing any testing, battery must be fully charged.

To test charging system:

1. Inspect charging system fuse. If damaged, replace before continuing.
2. Visually inspect system components and wiring. Look for damaged or loose wire connections, including battery cables.
3. Set DVOM to DC volts, place red (positive) lead of tester on rectifier-regulator negative (-) post and black (negative) lead to battery negative (-) terminal. Run engine and observe volt reading on meter. If voltage is 0.5 VDC or less, continue with testing. If voltage is higher than 0.5 VDC, inspect and repair wiring/connections as needed (insufficient ground).
4. Perform output tests a and b for charging system using DVOM set to DC volts OR perform test c using carbon pile test tool.
 - a. With engine off and key switch in OFF position, measure voltage at battery. If less than 12.4 VDC, recharge battery and retest. If 12.5 VDC continue with tests.
 - b. Run engine at high speed no electrical or mechanical load (greater than 3000 RPM). After running 1 minute, measure voltage at battery.
 - i. If voltage increases to between 13-15 VDC, system is working correctly.
 - ii. If voltage increases to 15.5 VDC or higher, system is overcharging. Replace rectifier-regulator.
 - iii. If voltage stays at 12.5 VDC or decreases, charging system is NOT operating, proceed to step 5.

Electrical System

- c. If a carbon pile test tool is available, connect tool to battery posts (Red positive +/Black negative -) turn load knob counterclockwise (no load). Start and run engine at high speed (3600 RPM optimal), adjust carbon pile voltage to 12 volts and observe amperage on amp meter. Displayed amperage should be near or at maximum rated system output. (Follow tool directions for carbon pile test procedures.)

Condition	Conclusion
Charge rate increases when load is applied.	Charging system is OK and battery was fully charged.
Charge rate does not increase when load is applied	Test stator and rectifier-regulator (steps 5-8).

5. With engine off, remove terminal block cover from rectifier-regulator and inspect ring terminals and rectifier-regulator studs for corrosion/arcing/damage. Repair/replace as needed. If OK, proceed to next test.
6. Label each yellow stator wire (1, 2, 3) on ring terminal sheathing. Remove nuts retaining stator eyelets and cover each ring terminal with electrical tape, to ensure no accidental contact can be made.

NOTE: DVOM must be able to read to 0.05 ohms.

Set DVOM to AC volts, place test lead to each yellow stator wire ring terminal (under tape). Run engine at high speed and monitor voltage. Measure between each stator lead and ground (1-ground, 2-ground, 3-ground).

Condition	Conclusion
Voltage is 17 volts AC or more.	Stator is OK.
Voltage is less than 17 volts AC.	Stator is faulty. Continue with steps 7 and 8).

7. With engine off and stator ring terminals removed from rectifier-regulator, check for resistance/continuity between across stator leads (yellow wires; 1-2, 1-3, 2-3).

Condition	Conclusion
Resistance is 0.1/0.2 ohms.	Stator coil is OK.
Resistance is 0 ohms.	Stator is shorted; replace.
Resistance is infinity ohms/no continuity.	Stator is open; replace.

8. With engine off and stator ring terminals removed from rectifier-regulator, check for resistance/continuity from stator leads (yellow wires) to ground.

Condition	Conclusion
Resistance is infinity ohms (no continuity).	Stator is OK (not shorted to ground).
Resistance (or continuity) measured.	Stator leads are shorted to ground; replace.

9. If stator tests good (steps 5-8), but system was identified in step 4 as not working, failure is likely with rectifier-regulator. Replace rectifier-regulator, retest system to confirm repairs (step 4).

FUSES (High Output Charging System)

Engines equipped with a high output charging system have one (1) 60-amp large blade type automotive fuse, in addition to three (3) blade type automotive fuses. However, 30-amp fuse is then nonfunctional as 30-amp charging circuit has been disabled. Purple charge wire ring terminals in main engine wiring harness are completely sealed and retained using a special heat shrink cap for non use. No service is required for this circuit.

Replacement fuses must have same rating as blown fuse. Use fuse chart below to determine correct fuse.

Wire Color	Fuse Rating
2 Purple Wires	30-amp Fuse
1 Red Wire w/Black Stripe 1 Red Wire w/White Stripe	10-amp Fuse
2 Red Wires	10-amp Fuse
High Output Charging System adds	
In separate wiring harness	Rehiko 60-amp Fuse

Fuse Replacement

- Shut engine off and remove key.
- Locate fuse holders.
- Remove fuse cover and pull out fuse.
- Inspect fuse for a solid fusible link or a broken fusible link. Replace fuse if fusible link is broken. If you are not sure if fusible link is broken, replace fuse.
- Insert fuse into fuse holder until it is seated properly. Install fuse cover.
- If replacement fuse fails, there is a problem within circuit. Diagnostics are required. Identify which circuit is affected (see EFI System for electrical schematic) by identifying failed fuse/circuit. Perform troubleshooting procedures appropriate for circuit fuse that failed.
- Install fuse holder into fuse cover.

IGNITION SYSTEM

Spark Plug

Spark Plug Component and Details

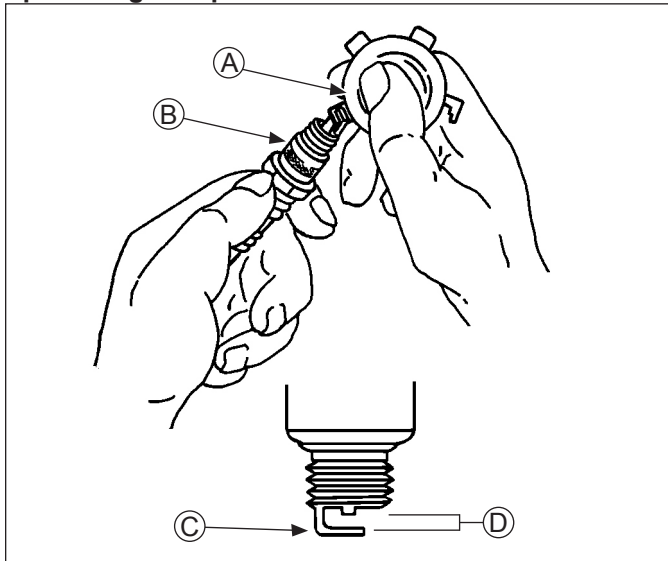

A	Wire Gauge	B	Spark Plug
C	Ground Electrode	D	Gap

NOTE: Do not clean spark plug in a machine using abrasive grit. Some grit could remain in spark plug and enter engine causing extensive wear and damage.

Engine misfire or starting problems are often caused by a spark plug that has improper gap or is in poor condition.

Engine is equipped with following spark plugs:

Gap	0.76 mm (0.030 in.)
Thread Size	14 mm
Reach	19.1 mm (3/4 in.)
Hex Size	15.9 mm (5/8 in.)

Refer to Maintenance for Repairs/Service Parts.

Service

Clean out spark plug recess. Remove plug and replace.

1. Check gap using wire feeler gauge. Adjust gap to 0.76 mm (0.030 in.).
2. Install plug into cylinder head.
3. Torque plug to 27 N·m (20 ft. lb.).

Inspection

Inspect each spark plug as it is removed from cylinder head. Deposits on tip are an indication of general condition of piston rings, valves, and carburetor.

Normal and fouled plugs are shown in following photos:

Normal

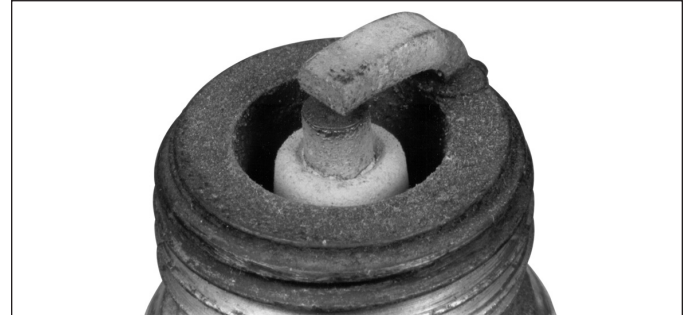

Plug taken from an engine operating under normal conditions will have light tan or gray colored deposits. If center electrode is not worn, plug can be set to proper gap and reused.

Worn



On a worn plug, center electrode will be rounded and gap will be greater than specified gap. Replace a worn spark plug immediately.

Wet Fouled



A wet plug is caused by excess fuel or oil in combustion chamber. Excess fuel could be caused by a restricted air cleaner, a carburetor problem, or operating engine with too much choke. Oil in combustion chamber is usually caused by a restricted air cleaner, a breather problem, worn piston rings, or valve guides.

Electrical System

Carbon Fouled



Soft, sooty, black deposits indicate incomplete combustion caused by a restricted air cleaner, over rich carburetion, weak ignition, or poor compression.

Overheated



Chalky, white deposits indicate very high combustion temperatures. This condition is usually accompanied by excessive gap erosion. Lean carburetor settings, an intake air leak, or incorrect spark timing are normal causes for high combustion temperatures.

BATTERY

A 12-volt battery with 400 cold cranking amps (cca) is generally recommended for starting in all conditions. A smaller capacity battery is often sufficient if an application is started only in warmer temperatures. Refer to following table for minimum capacities based on anticipated ambient temperatures. Actual cold cranking requirement depends on engine size, application, and starting temperatures. Cranking requirements increase as temperatures decrease and battery capacity shrinks. Refer to equipment's operating instructions for specific battery requirements.

Battery Size Recommendations

Temperature	Battery Required
Above 32°F (0°C)	200 cca minimum
0°F to 32°F (-18°C to 0°C)	250 cca minimum
-5°F to 0°F (-21°C to -18°C)	300 cca minimum
-10°F (-23°C) or below	400 cca minimum

If battery charge is insufficient to turn over engine, recharge battery.

Battery Maintenance

Regular maintenance is necessary to prolong battery life.

Battery Test

To test battery, follow manufacturer's instructions.

Starter System

NOTE: Do not crank engine continuously for more than 10 seconds. Allow a 60 second cool down period between starting attempts. Failure to follow these guidelines can burn out starter motor.

NOTE: If engine develops sufficient speed to disengage starter but does not keep running (a false start), engine rotation must be allowed to come to a complete stop before attempting to restart engine. If starter is engaged while flywheel is rotating, starter pinion and flywheel ring gear may clash and damage starter.

NOTE: If starter does not crank engine, shut off starter immediately. Do not make further attempts to start engine until condition is corrected.

NOTE: Do not drop starter or strike starter frame. Doing so can damage starter.

Engines in this series use solenoid shift starters.

Troubleshooting-Starting Difficulties

Condition	Possible Cause	Conclusion
Starter does not energize.	Battery	Check specific gravity of battery. If low, recharge or replace battery as necessary.
	Wiring	Clean corroded connections and tighten loose connections. Replace wires in poor condition and with frayed or broken insulation.
	Starter Switch or Solenoid	By-pass switch or solenoid with a jumper wire. If starter cranks normally, replace faulty components. Remove and perform individual solenoid test procedure.
Starter energizes but turns slowly.	Battery	Check specific gravity of battery. If low, recharge or replace battery as necessary.
	Brushes	Check for excessively dirty or worn brushes and commutator. Clean using a coarse cloth (not emery cloth). Replace brushes if excessively or unevenly worn.
	Transmission or Engine	Make sure clutch or transmission is disengaged or placed in neutral. This is especially important on equipment with hydrostatic drive. Transmission must be exactly in neutral to prevent resistance which could keep engine from starting. Check for seized engine components such as bearings, connecting rod, and piston.

Starter System

SOLENOID SHIFT ELECTRIC STARTERS

Solenoid Shift Starter Components

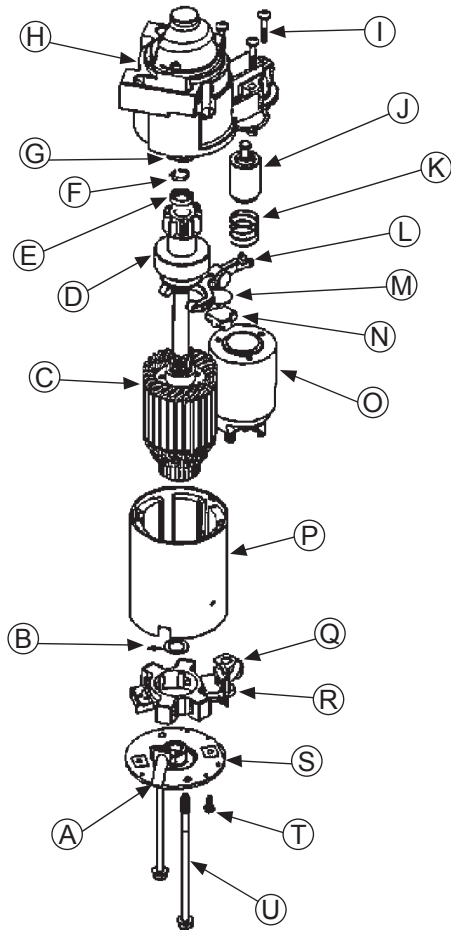

A	Tube	B	Washer
C	Armature	D	Drive
E	Stop	F	Retaining Ring
G	Collar	H	Drive End Cap
I	Screw	J	Plunger
K	Spring	L	Lever
M	Plate	N	Plug
O	Solenoid	P	Frame and Field
Q	Brush Holder	R	Nut
S	Commutator End Plate	T	Screw
U	Bolt		

When power is applied to starter, armature rotates. As armature rotates, drive pinion moves out on drive shaft splines and into mesh with flywheel ring gear. When pinion reaches end of drive shaft, it rotates flywheel and cranks engine.

When engine starts, flywheel rotates faster than starter armature and drive pinion. This moves drive pinion out of mesh with ring gear and into retracted position. When power is removed from starter, armature stops rotating and drive pinion is held in retracted position by anti-drift spring.

Starter Disassembly

NOTE: Do not reuse old retainer.

NOTE: Do not soak armature or use solvent when cleaning. Wipe clean using a soft cloth, or use compressed air.

1. Remove nut and disconnect positive (+) brush lead/ bracket from solenoid terminal.
2. Remove screws securing solenoid to starter.
3. Remove retaining ring from armature shaft using either a retaining ring pliers or snap ring removal tool, as described in Steps 4, and 5. Do not reuse old retainer.
4. Remove thru (larger) bolts.
5. Remove commutator end plate assembly, containing brush holder, brushes, springs, and locking caps. Remove thrust washer from inside commutator end.
6. Remove frame from armature and drive end cap.
7. Remove rubber grommet and backing plate from end cap.
8. Take out drive lever and pull armature out of drive end cap.
9. Remove thrust washer from armature shaft.
10. Push stop collar down to expose retaining ring.
11. Remove retainer from armature shaft. Save stop collar.
12. Remove drive pinion assembly from armature.
13. Clean parts as required.

Inspection

Check drive pinion and inspect following areas:

- Pinion teeth for abnormal wear or damage.
- Surface between pinion and clutch mechanism for nicks or irregularities which could cause seal damage.
- Check drive clutch by holding clutch housing and rotating pinion. Pinion should rotate in only 1 direction.

Brushes and Springs

Detail

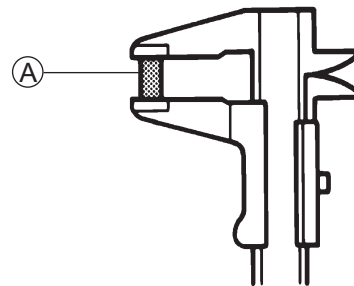

A Wear Limit Length

Inspect both springs and brushes for wear, fatigue, or damage. Measure length of each brush. Minimum length for each brush is 7.6 mm (0.300 in.). Replace brushes if they are worn, undersize, or condition is questionable.

Armature Components and Details

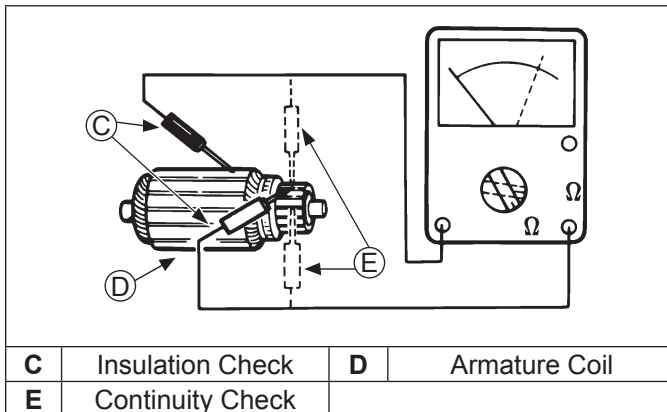
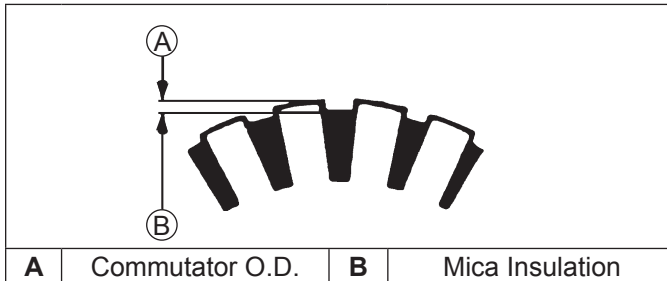

1. Clean and inspect commutator (outer surface). Mica insulation must be lower than commutator bars (undercut) to ensure proper operation of commutator.
2. Use an ohmmeter set to Rx1 scale. Touch probes between 2 different segments of commutator, and check for continuity. Test all segments. Continuity must exist between all or armature is bad.
3. Check for continuity between armature coil segments and commutator segments. There should be no continuity. If continuity exists between any 2 armature is bad.
4. Check armature windings/insulation for shorting.

Shift Fork

Check that shift fork is complete, and pivot and contact areas are not excessively worn, cracked, or broken.

Brush Replacement

4 brushes and springs are serviced as a set. Use a new Rehlko brush and spring kit if replacement is necessary.

1. Perform steps 1-5 in Starter Disassembly.
2. Remove screws securing brush holder assembly to end cap (plate). Note orientation for reassembly later. Discard old brush holder assembly.
3. Clean component parts as required.
New brushes and springs come preassembled in a brush holder with a protective sleeve that will also serve as an installation tool.
4. Perform steps 10-13 in Starter Reassembly sequence. If starter has been disassembled, installation must be done after armature, drive lever, and frame are installed.

Starter Reassembly

NOTE: Always use a new retainer. Do not reuse old retainers that have been removed.

NOTE: Correctly installed, center pivot section of drive lever will be flush or below machined surface of housing.

1. Apply drive lubricant to armature shaft splines. Install drive pinion onto armature shaft.
 2. Install and assemble stop collar/retainer assembly.
 - a. Install stop collar down onto armature shaft with counter bore (recess) up.
 - b. Install a new retainer in larger (rear) groove of armature shaft. Squeeze with a pliers to compress it in groove.
 - c. Slide stop collar up and lock it into place, so recess surrounds retainer in groove. If necessary, rotate pinion outward on armature splines against retainer to help seat collar around retainer.
 3. Install offset thrust (stop) washer so smaller offset of washer faces retainer/collar.
 4. Apply a small amount of oil to bearing in drive end cap, and install armature with drive pinion.
 5. Lubricate fork end and center pivot of drive lever with drive lubricant. Position fork end into space between captured washer and rear of pinion.
 6. Slide armature into drive end cap and at same time seat drive lever into housing.
 7. Install rubber grommet into matching recess of drive end cap. Molded recesses in grommet should be out, matching and aligned with those in end cap.
 8. Install frame, with small notch forward, onto armature and drive end cap. Align notch with corresponding section in rubber grommet. Install drain tube in rear cutout, if it was removed previously.
 9. Install flat thrust washer onto commutator end of armature shaft.
 10. Starter reassembly when replacing brushes/brush holder assembly:
 - a. Hold starter assembly vertically on end housing, and carefully position assembled brush holder assembly, with supplied protective tube, against end of commutator/armature. Mounting screw holes in metal clips must be up/out. Slide brush holder assembly down into place around commutator, and install positive (+) brush lead grommet in cutout of frame. Protective tube may be saved and used for future servicing.
- Starter reassembly when not replacing brushes/brush holder assembly:
- a. Carefully unhook retaining caps from brush assemblies. Do not lose springs.

Starter System

- b. Position brushes back in their slots so they are flush with I.D. of brush holder assembly. Insert brush installation tool (with extension), or use tube described above from a prior brush installation, through brush holder assembly, so holes in metal mounting clips are up/out.
 - c. Install brush springs and snap on retainer caps.
 - d. Hold starter assembly vertically on end housing, and carefully place tool (with extension) and assembled original brush holder assembly onto end of armature shaft. Slide brush holder assembly down into place around commutator, install positive (+) brush lead grommet in cutout of frame.
11. Install end cap onto armature and frame, aligning thin raised rib in end cap with corresponding slot in grommet of positive (+) brush lead.
 12. Install thru bolts and brush holder mounting screws. Torque bolts to 5.6-9.0 N·m (49-79 in. lb.) and brush holder mounting screws to 2.5-3.3 N·m (22-29 in. lb.).
 13. Hook plunger behind upper end of drive lever and install spring into solenoid. Insert mounting screws through holes in drive end cap. Use these to hold solenoid gasket in position, then mount solenoid. Torque screws to 4.0-6.0 N·m (35-53 in. lb.).
 14. Connect positive (+) brush lead/bracket to solenoid and secure with nut. Torque nut to 8-11 N·m (71-97 in. lb.). Do not overtighten.

Solenoid Tests

NOTE: DO NOT leave 12 volt test leads connected to solenoid for any time over what is necessary for performing each of individual tests. Internal damage to solenoid may occur.

Disconnect all leads from solenoid including positive brush lead attached to lower stud terminal. Remove mounting hardware and separate solenoid from starter for testing.

To test solenoid pull-in coil/plunger:

Actuation

1. Use a 12 volt power supply and 2 test leads.
2. Connect 1 lead to flat spade S/start terminal on solenoid. Momentarily connect other lead to lower large post terminal.

When connection is made solenoid should energize (audible click) and plunger retract. Repeat test several times.

Continuity

1. Use an ohmmeter set to audible or Rx2K scale, and connect 2 ohmmeter leads to 2 large post terminals.
2. Perform solenoid pull-in coil/plunger actuation test and check for continuity. Ohmmeter should indicate continuity. Repeat test several times.

To test solenoid hold-in coil:

Function

1. Connect a 12 volt test lead to flat spade S/start terminal on solenoid and other lead to body or mounting surface of solenoid.
2. Manually push plunger IN and check if coil holds plunger retracted. Do not allow test leads to remain connected to solenoid for a prolonged period of time.

Continuity

1. Use an ohmmeter set to audible or Rx2K scale, and connect 2 ohmmeter leads to 2 large post terminals.
2. Perform preceding solenoid hold-in coil function test and check for continuity. Meter should indicate continuity. Repeat test several times.

Condition	Conclusion
Solenoid fails to activate.	Replace solenoid.
No continuity is indicated.	
Plunger fails to stay retracted.	

Disassembly/Inspection and Service



⚠ WARNING

Accidental Starts can cause severe injury or death.

Disconnect and ground spark plug lead(s) before servicing.

Before working on engine or equipment, disable engine as follows: 1) Disconnect spark plug lead(s). 2) Disconnect negative (-) battery cable from battery.

External Engine Components

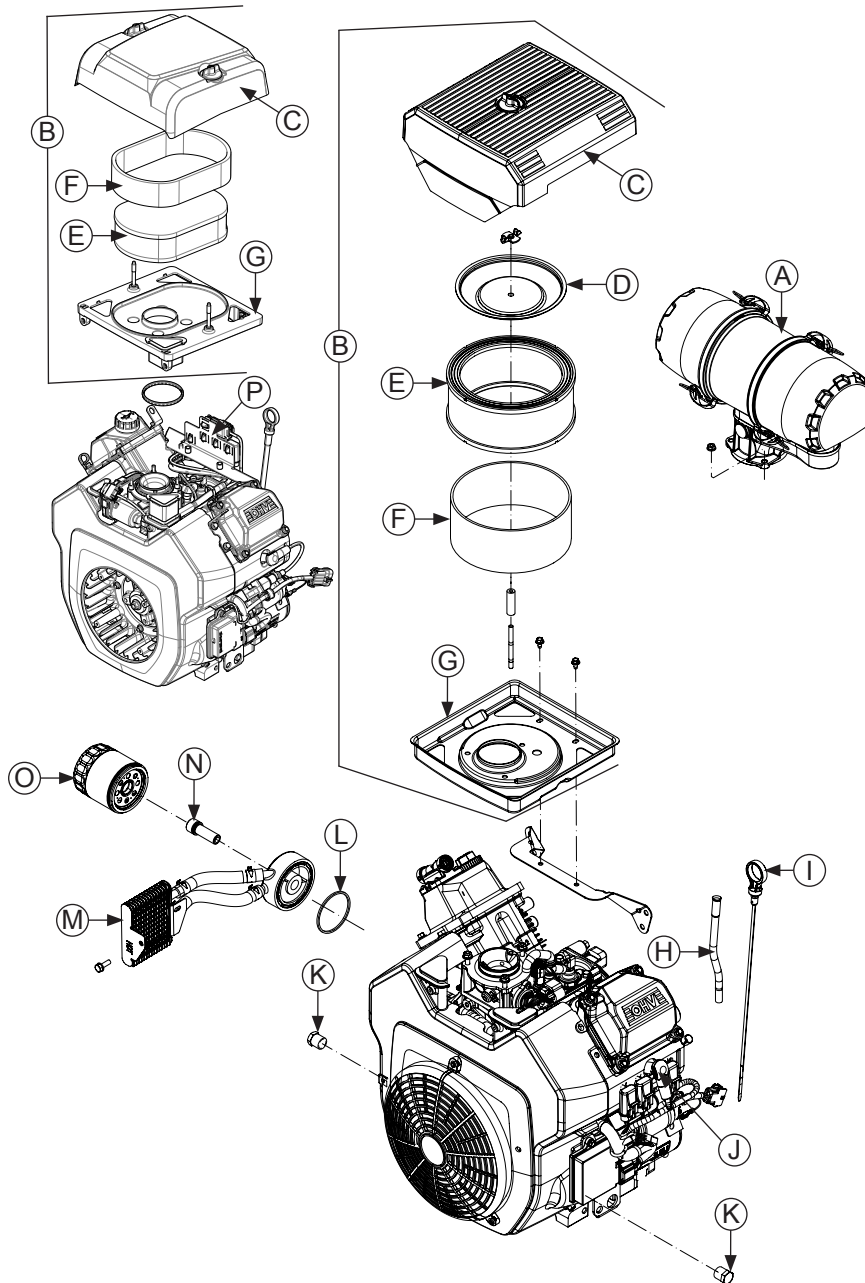

A	Heavy-Duty Air Cleaner	B	Low-Profile Air Cleaner	C	Low-Profile Air Cleaner Cover	D	Element Cover
E	Paper Element	F	Precleaner	G	Low-Profile Air Cleaner Base	H	Dipstick Tube
I	Dipstick	J	Spark Plug Lead	K	Oil Drain Plug	L	O-ring
M	Oil Cooler	N	Nipple	O	Oil Filter	P	LPAC Support Bracket

Disassembly/Inspection and Service

Clean all parts thoroughly as engine is disassembled. Only clean parts can be accurately inspected and gauged for wear or damage. There are many commercially available cleaners that will quickly remove grease, oil, and grime from engine parts. When such a cleaner is used, follow manufacturer's instructions and safety precautions carefully.

Make sure all traces of cleaner are removed before engine is reassembled and placed into operation. Even small amounts of these cleaners can quickly break down lubricating properties of engine oil.

Disconnect Spark Plug Leads

NOTE: Pull on boot only, to prevent damage to spark plug lead.

Disconnect leads from spark plugs.

Drain Oil from Crankcase and Remove Oil Filter

NOTE: Some models are equipped with an oil drain valve.

1. Remove oil fill cap, dipstick, and 1 oil drain plug.
2. Allow ample time for oil to drain from crankcase and oil filter.
3. Remove and discard oil filter.

Remove Oil Cooler (if equipped)

1. Use an 8 mm Allen wrench to remove oil filter threaded nipple.
2. Separate filter adapter from closure plate, leaving oil lines attached. Remove screws mounting oil cooler to blower housing, then remove cooler, lines, and filter adapter as an assembly.

Remove Muffler (if equipped)

NOTE: Unless oxygen sensor is damaged or malfunctioning, disassembly from muffler is unnecessary.

1. Disconnect oxygen sensor connector from wire harness.
2. Carefully remove sensor plug from bracket (ETB ECH EFI only).
3. Remove exhaust system and attaching hardware from engine. On engines equipped with port liners, remove them now.
4. Remove oxygen sensor.

Remove Air Cleaner Assembly (if equipped)

Heavy Duty Air Cleaner

1. Remove nuts securing air cleaner assembly to throttle body.
2. Remove screws securing air cleaner assembly to air cleaner bracket and remove air cleaner assembly.

Low-Profile Air Cleaner ETB ECH EFI

1. Loosen retaining knobs and remove cover.
2. Lift off element with precleaner.

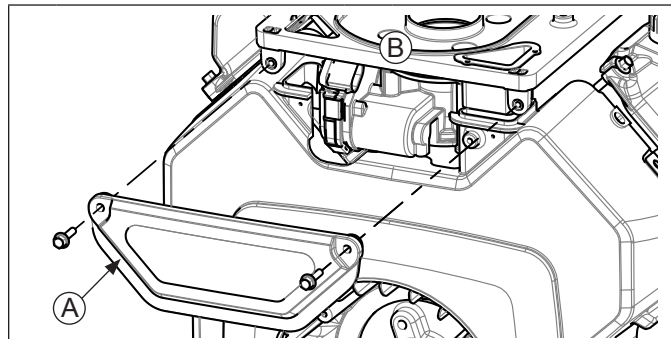

A	ETB Cover	B	Air Cleaner Base
----------	-----------	----------	------------------

3. Remove screws and ETB cover from front of base.
4. Remove screws securing base to LPAC support bracket (with fuses).
5. Remove nuts securing base to electronic throttle body; lift off base and O-ring.

Low-Profile Air Cleaner

1. Loosen retaining knob and remove cover.
2. Remove wing nut from element cover.
3. Remove element cover, air cleaner element with precleaner, and stud seal.
4. Remove nuts.
5. Remove screws securing base and then remove base.

Remove Throttle Control Panel (if equipped)

1. Disconnect throttle control cable.
2. Remove screws securing throttle control panel and remove panel from blower housing.

External Governor Control (ECH EFI) (if equipped)

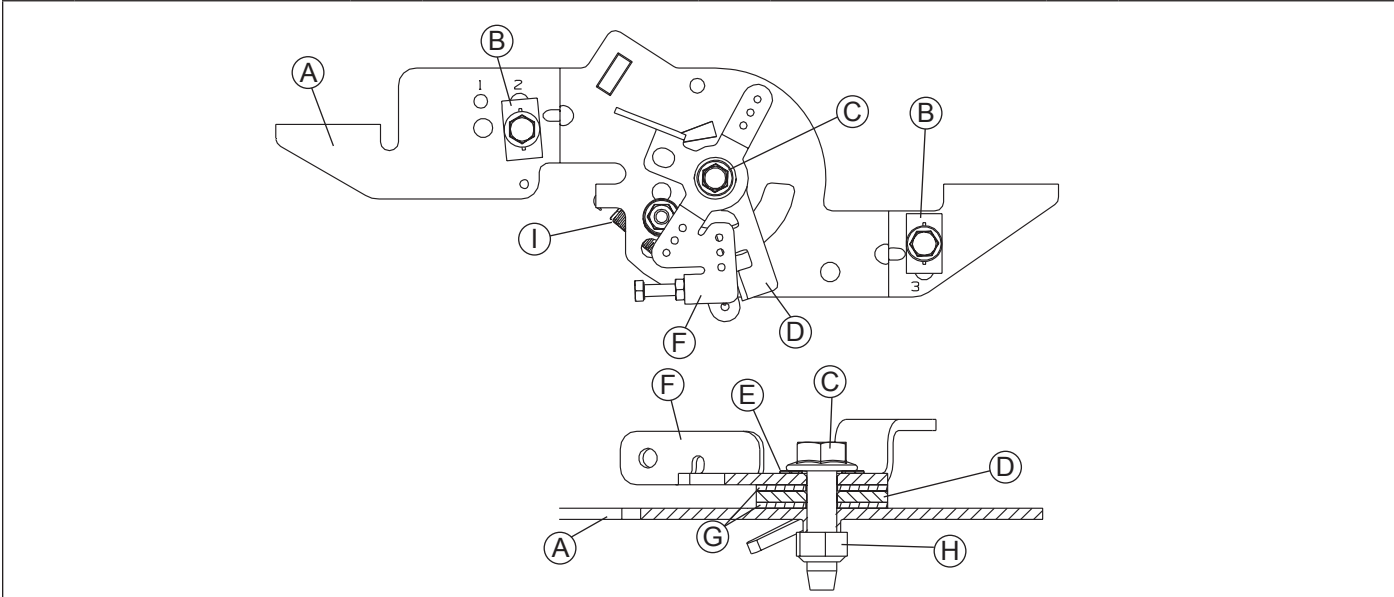

A	Speed Control Bracket	B	Cable Clamp	C	Screw	D	Throttle Actuator Lever (bottom)
E	Spring Washer	F	Throttle Control Lever (top)	G	Flat Washer	H	Nut
I	Return Spring						

Remove External Governor Controls (if equipped)

1. Disconnect governor spring attaching governor lever to throttle actuator lever.
2. Disconnect throttle linkage spring. Remove throttle linkage bushing and throttle linkage from governor lever.
3. Loosen nut and remove governor lever from cross shaft.

Disassembly/Inspection and Service



⚠ WARNING

Explosive Fuel can cause fires and severe burns.

Do not fill fuel tank while engine is hot or running.

Gasoline is extremely flammable and its vapors can explode if ignited. Store gasoline only in approved containers, in well ventilated, unoccupied buildings, away from sparks or flames. Spilled fuel could ignite if it comes in contact with hot parts or sparks from ignition. Never use gasoline as a cleaning agent.

Fuel Pump (ETB ECH EFI & ECH EFI)

Remove Lift Fuel Pump and Fuel Pump Module

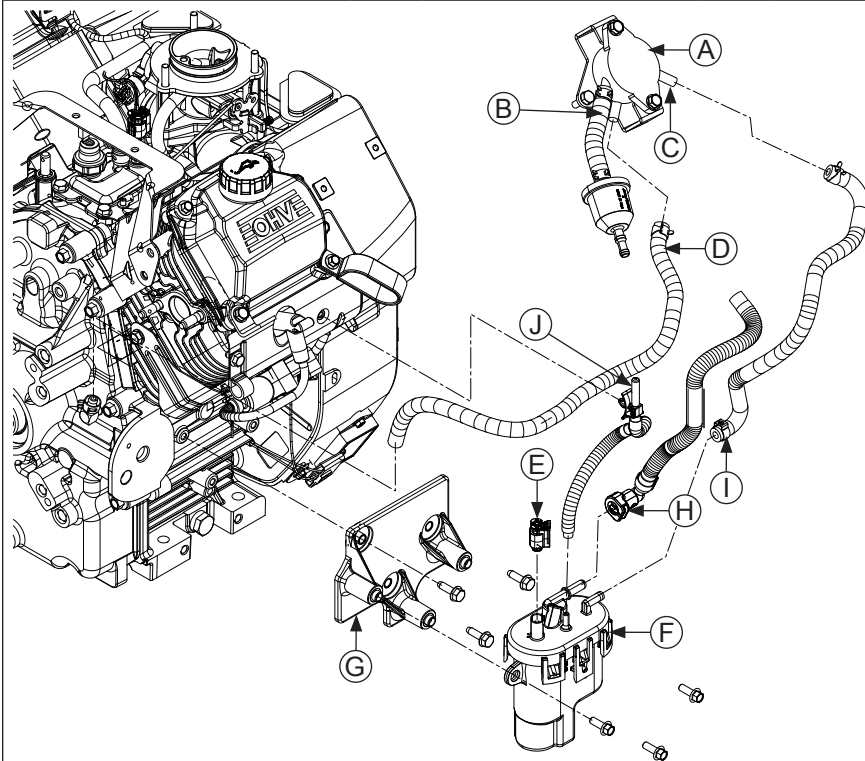

A	Pulse Pump	B	Inlet Hose	C	Outlet to Fuel Pump Module	D	Pulse Hose
E	Electrical Connector	F	Fuel Pump Module	G	Fuel Pump Module Baffle	H	High Pressure Fuel Line Connector
I	Oetiker Clamp	J	Purge Port/Vent Fitting				

Remove Lift Fuel Pump (if equipped)

Pulse Style Pumps

1. Disconnect fuel lines at pump outlet and in-line fuel filter on tank to pulse pump line.
2. Disconnect pulse (vacuum) line from crankcase; remove line from clamp on outer baffle.
3. Remove screws securing fuel pump to bracket on blower housing.
4. Note or mark orientation of fuel pump, then remove fuel pump with lines attached. On ETB ECH EFI engines, route pulse line through large clamp on valve cover.

Mechanical Style Pumps

Mechanical style fuel pump is part of valve cover assembly.

1. Disconnect fuel lines at pump outlet and in-line fuel filter.
2. Fuel pump will be removed with valve cover. Refer to valve cover removal procedure.

Remove Fuel Pump Module (ETB ECH EFI & ECH EFI)

1. Remove screws securing fuel pump module to baffle.
2. If engine has a lift fuel pump, inlet fuel line should have been removed from fuel pump, keeping it attached at fuel pump module.
Do not cut Oetiker clamp unless fuel line or fuel pump module are being replaced.
3. Disconnect yellow electrical connector by pulling up on grey tab to release.
4. Wrap a shop towel completely around high pressure fuel line connector.
5. Press release button(s) and slowly pull connector away from fuel pump module, allowing shop towel to absorb any residual fuel in high pressure fuel line. Any spilled fuel must be completely wiped up immediately.
6. Disconnect vent hose from top of fuel pump module. Remove fuel pump module (with inlet fuel line) from engine.
7. Remove screws securing fuel pump module baffle; remove baffle.

Remove Electronic Control Unit (ECU) (ETB ECH EFI & ECH EFI)

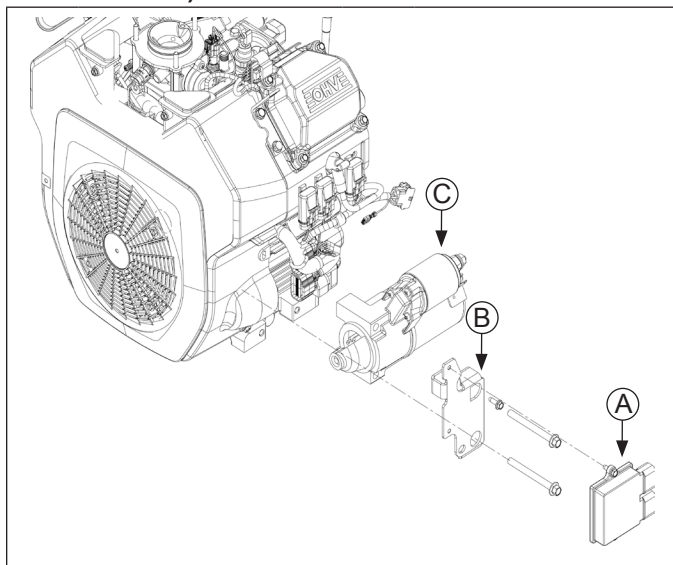

A	Electronic Control Unit (ECU)	B	ECU Bracket
C	Starter		

1. Remove screws securing ECU to bracket.
2. Disconnect Black and Grey electrical connectors from ECU.

Remove Electronic Control Unit Bracket and Electric Starter Motor

1. Disconnect leads from starter.
2. Remove screw securing ECU bracket to blower housing.

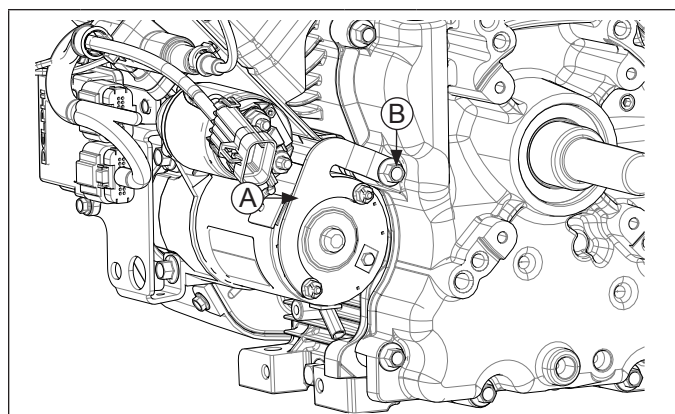

A	Rear Starter Bracket	B	Closure Plate Screw
----------	----------------------	----------	---------------------

3. If equipped, remove screw securing rear starter bracket to closure plate.
4. Remove screws securing ECU bracket and starter; remove bracket and starter.
ETB ECH EFI engines with high output charging system have black ground lead ring terminal and lock washer on lower starter screw.

Remove Throttle Body

Throttle Body Components (ECH EFI)

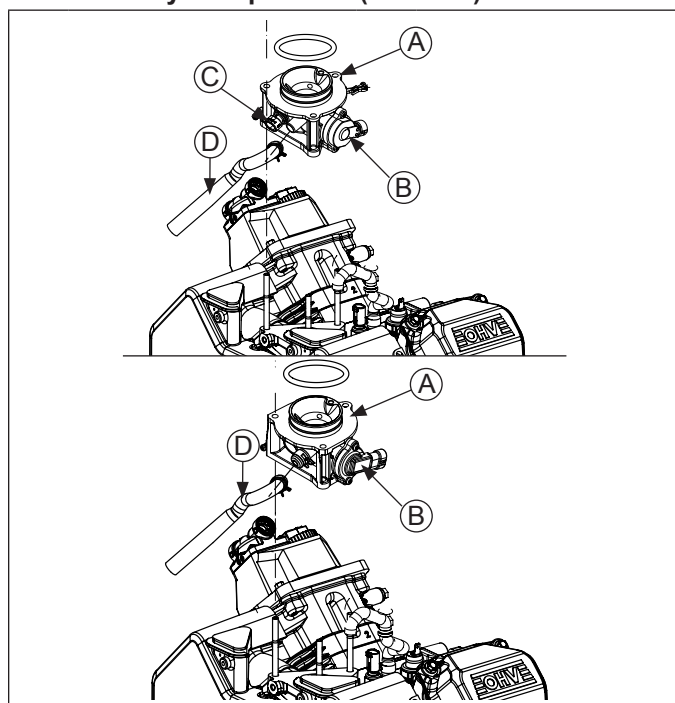

A	Throttle Body	B	Throttle Position Sensor (TPS)
C	Intake Air Temperature (IAT) Sensor	D	Breather Tube

1. Disconnect breather tube from throttle body.
2. On earlier engines with separate intake air temperature (IAT) and MAP sensors, disconnect IAT sensor from throttle body.
3. Disconnect throttle position sensor connector.
4. Disconnect vent hose from throttle body.

Disassembly/Inspection and Service

5. Slide throttle body off intake manifold.

Electronic Throttle Body Components (ETB ECH EFI)

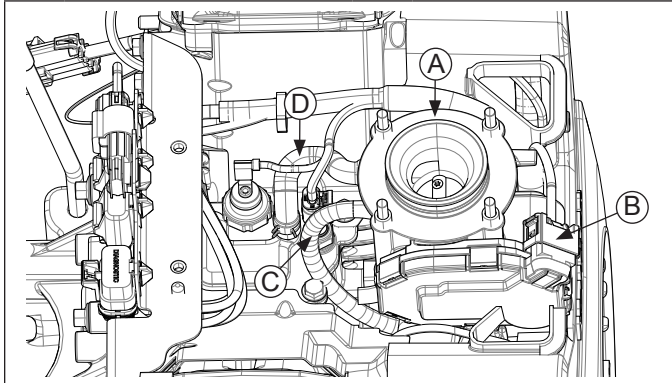

A	Electronic Throttle Body (ETB)	B	TPS/ETB Connector
C	Vent Hose	D	Breather Hose

1. Slide clamp and disconnect breather hose from breather cover.
2. Disconnect vent hose from throttle body.

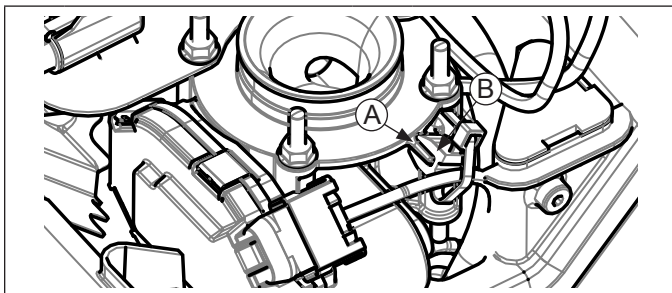

A	ETB Rib	B	Wire Tie Retention Teeth
---	---------	---	--------------------------

3. Disconnect TPS/ETB connector. Carefully remove retention teeth of wire tie securing TPS/ETB lead to rib on ETB.
4. Lift ETB with O-ring off intake manifold.

Disconnect Fuses and Remove ETB LPAC Support Bracket

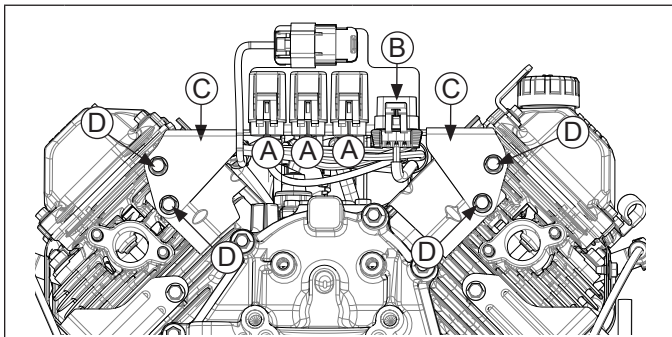

A	Fuses	B	Diagnostic Connector
C	LPAC Support Bracket	D	Screw

1. Disconnect fuse connectors on ETB LPAC support bracket and allow them to hang. Disconnect diagnostic plug from cap.

2. Remove screws securing bracket with fuse and diagnostic caps.

On oil filter side of certain engines, screw closest to exhaust port may also secure engine temperature sensor lead between bracket and baffle. Note placement for reassembly.

Remove High Output Charging System Rectifier-Regulator and Electronic Throttle Body Components (ETB ECH EFI)

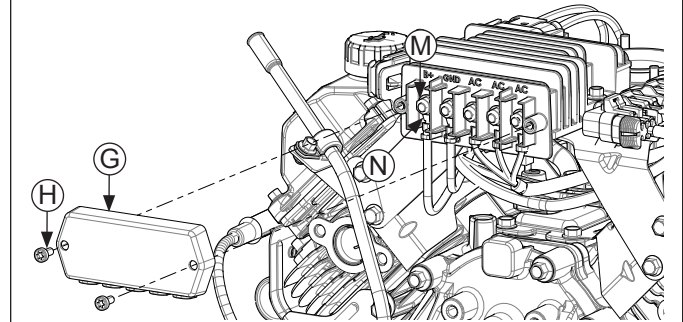
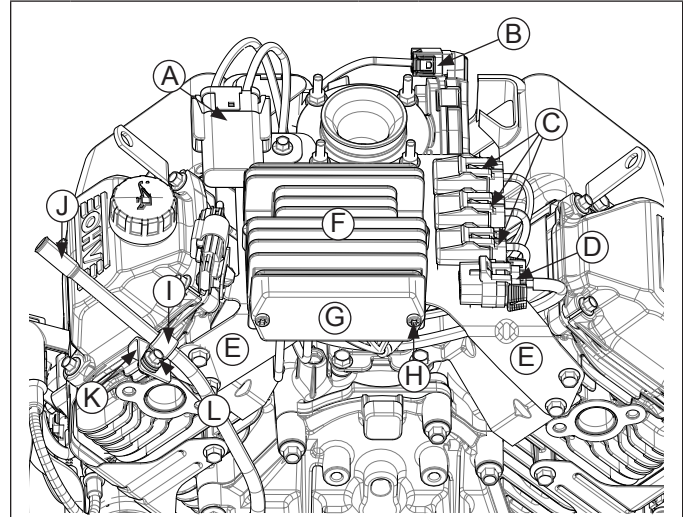

A	High Output Charging Fuse	B	TPS/ETB Connector
C	Fuses	D	Diagnostic Connector
E	Rectifier-Regulator Bracket	F	Rectifier-Regulator
G	Terminal Block Cover	H	Torx Screw
I	Clamp	J	Dipstick Tube
K	Support Bracket	L	Screw
M	Nut	N	Ring Terminal

NOTE: Unless rectifier-regulator and high output charging fuse cover/bracket are being replaced, disassembly from regulator bracket is unnecessary.

1. Remove fuses and diagnostic connector from caps.
2. Remove Torx screws and terminal block cover from rectifier-regulator.
3. Remove nuts and ring terminals from rectifier-regulator. Using a pen, mark each yellow stator wire 1, 2, 3.

Disassembly/Inspection and Service

- Remove nuts securing rectifier-regulator bracket and ETB; remove screws securing bracket to engine.

Some engines also have a dipstick tube support bracket secured with this bracket on #1 side. Remove screw and clamp securing tube to support bracket. Tube can stay in closure plate.

On oil filter side of certain engines, screw closest to exhaust port may also secure engine temperature sensor lead between bracket and baffle. Note placement for reassembly.

- Slide clamp and disconnect breather hose from breather cover.
- Disconnect vent hose from throttle body.

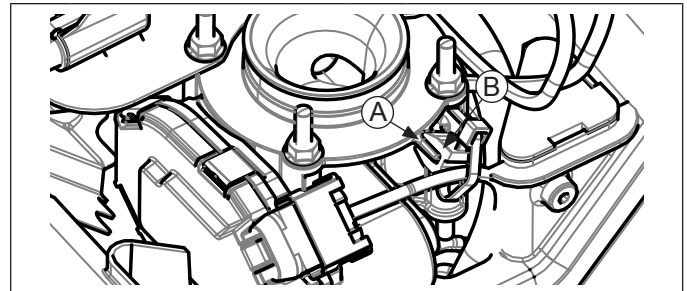

A	ETB Rib	B	Wire Tie Retention Teeth
----------	---------	----------	--------------------------

- Disconnect TPS/ETB connector. Carefully remove retention teeth of wire tie securing TPS/ETB lead to rib on ETB.

- Lift ETB with O-ring off intake manifold.

External Engine Components

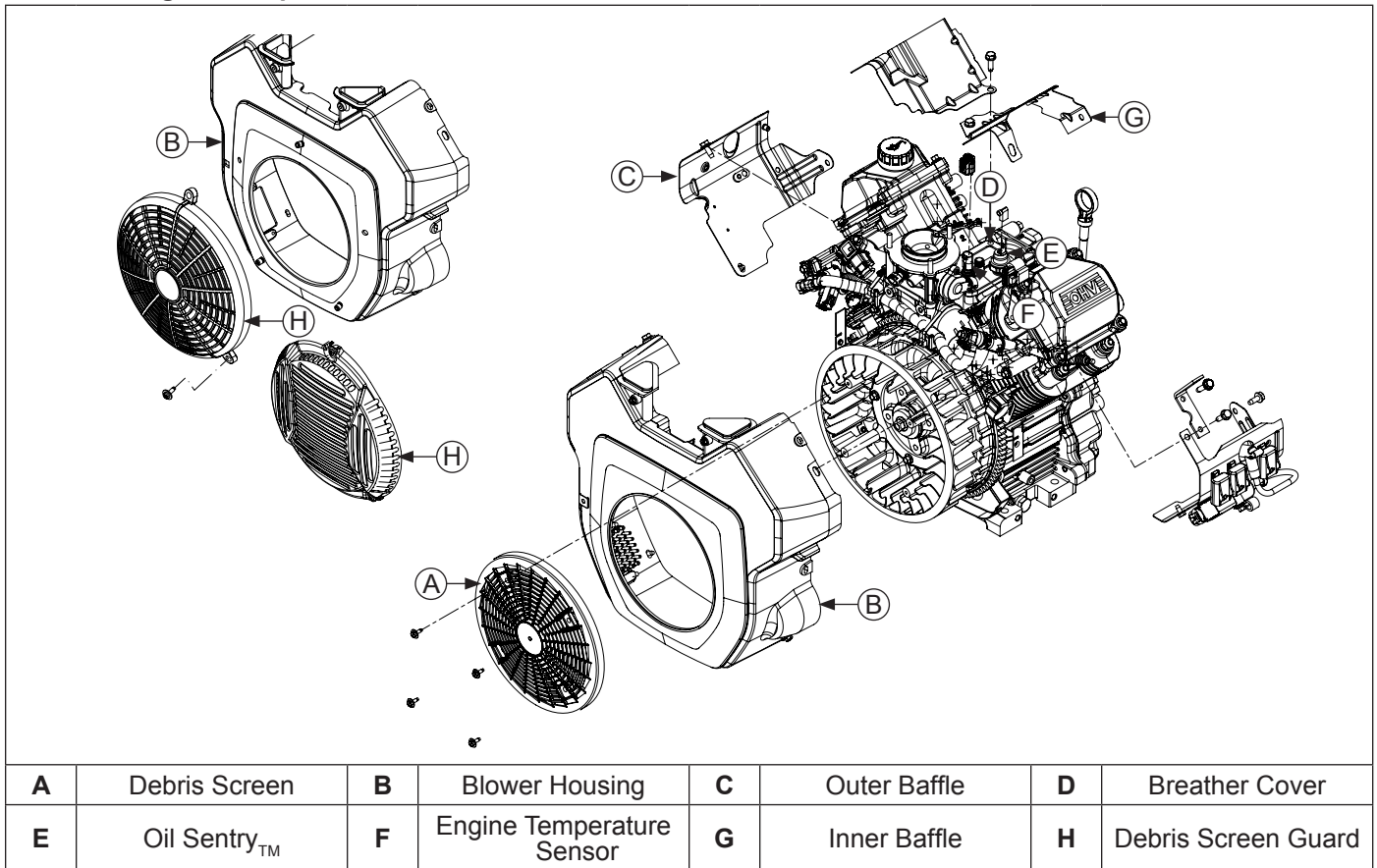

A	Debris Screen	B	Blower Housing	C	Outer Baffle	D	Breather Cover
E	Oil Sentry™	F	Engine Temperature Sensor	G	Inner Baffle	H	Debris Screen Guard

Remove Debris Screen Guard (if equipped)

Remove screws (and spacers) securing debris screen guard and remove debris screen guard.

Remove Debris Screen (if equipped)

NOTE: Fan will be loose, but cannot be removed until after blower housing is removed.

- Remove socket head cap screws securing metal grass screen and remove screen.
- Remove spacers, paying attention to curvature of spring washers between spacers and fan.
- If there is a plastic grass screen attached to fan, remove screws securing grass screen. Removing screen will expose screws fastening fan to flywheel.

Disassembly/Inspection and Service

Remove Outer Baffles and Blower Housing

NOTE: Some engines may have 2 fuses mounted to a bracket above ECU, and a third in-line fuse by rectifier-regulator.

1. Disconnect plug from rectifier-regulator (standard charging system).
2. Remove silver or green plated rectifier-regulator ground strap/ground lead screw fastened to blower housing then crankcase/backing plate. Rectifier-regulator does not have to be detached from blower housing.
3. Disconnect 3 fuse connectors on outer baffle and allow them to hang (standard charging system).
4. Remove screws securing outer baffles. Note location of any lifting strap and position of short screws for reassembly. Coil and any hoses may remain attached to baffle after being unplugged or disconnected.
5. Remove outer baffles.
On ETB ECH EFI engines, open clip on #1 side ignition coil screw and remove wiring harness; remove evap connector secured to #2 side baffle.
6. Remove remaining screws securing blower housing. Remove blower housing.

Remove Oil Sentry™

NOTE: This is optional. Removing Oil Sentry™ is not required to remove breather cover.

1. Disconnect lead from Oil Sentry™ switch.
2. Remove Oil Sentry™ switch from breather cover.

Remove Engine Temperature Sensor (ETB ECH EFI & ECH EFI) or Engine Temperature Sensor Lead (ETB ECH EFI)

Engines will have either a sensor mounted in breather cover or a sensor lead that secures on #2 cylinder valley baffle closest to exhaust port. Follow disassembly procedure for design on engine being serviced.

Engine Temperature Sensor (Breather Cover)

NOTE: Unless engine temperature sensor is damaged or malfunctioning, disassembly from breather cover is unnecessary.

1. Disconnect connector from engine temperature sensor.
2. Remove engine temperature sensor from breather cover.
3. If still connected, remove breather hose from breather cover.

Engine Temperature Sensor Lead

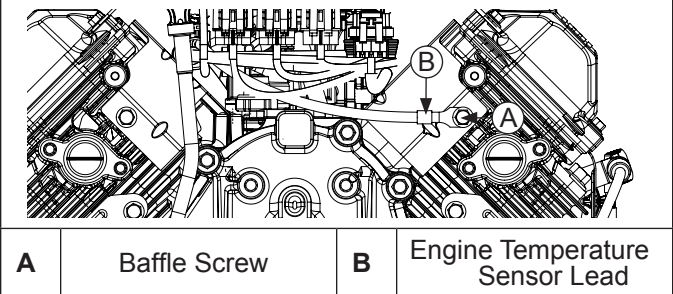

1. Remove screw securing inner baffle and engine temperature sensor lead.
2. Disconnect engine temperature sensor lead connector from wiring harness.

Remove Inner Baffles and Breather Cover

1. Remove screws securing inner baffles to breather cover/crankcase.
2. Remove inner (valley) baffles. On ETB ECH EFI engines, unplug wiring harness from #1 side baffle.
3. Remove remaining screws from breather cover.
4. Pry under protruding edge of breather cover with a screwdriver to break gasket seal. Do not pry on sealing surfaces as it could cause damage resulting in leaks.
5. Remove breather cover and gasket.

Intake Manifold Components (ETB ECH EFI & ECH EFI)

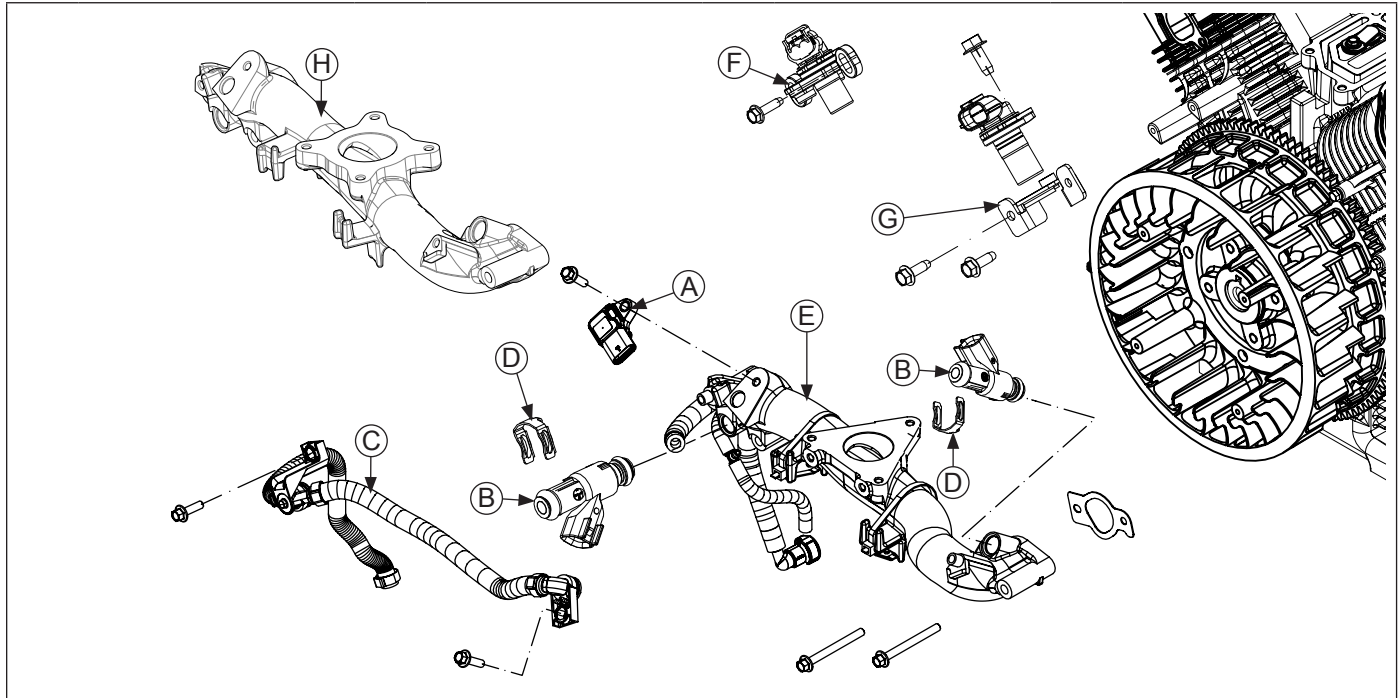

A	MAP or TMAP Sensor	B	Fuel Injector	C	Fuel Rail	D	Metal Retaining Clip
E	Intake Manifold	F	Crankshaft Position Sensor (Earlier Design Bracket)	G	Crankshaft Position Sensor (Later Design Bracket)	H	ETB Intake Manifold

Remove Crankshaft Position Sensor and Bracket

NOTE: Do not remove sensor from bracket unless sensor is being replaced.

1. Remove screws securing crankshaft position sensor bracket.
2. Disconnect electrical connector from crankshaft position sensor.

Remove Manifold Absolute Pressure (MAP) Sensor or Temperature/Manifold Absolute Pressure (TMAP) Sensor

NOTE: Unless sensor is damaged or malfunctioning, disassembly from intake manifold is unnecessary.

1. With a screwdriver, slide locking tab on electrical connector.
2. Detach connector.
3. Remove screw and pull sensor out of intake manifold.

Remove Fuel Injectors

NOTE: Unless fuel injectors are damaged or malfunctioning, disassembly from intake manifold is unnecessary.

NOTE: Make note of position of fuel injector before removing.

1. Disconnect electrical connector.
2. Remove screw and pull injector out of intake manifold for each injector.
3. When removed, pull metal retaining clip connecting fuel injector to fuel injector cap. There may be some fuel left in line. Any spilled fuel must be cleaned up immediately.

Remove Intake Manifold

1. Remove screw securing a ring terminal which is part of wiring harness to #1 side crankcase post.
2. On ETB ECH EFI standard charging system engines, remove purple B+ wire from rectifier-regulator connector. Unplug wiring harness from backing plate. Remove screw securing wiring harness to #1 side crankcase post.
3. Remove screws securing intake manifold to cylinder heads. Note which screws hold wiring clamp.
4. If replacing wiring harness, unclasp harness from clip using a screwdriver.
5. Remove intake manifold and intake manifold gaskets.
6. Leave wiring harness attached to manifold.

Disassembly/Inspection and Service

Cylinder Head Components

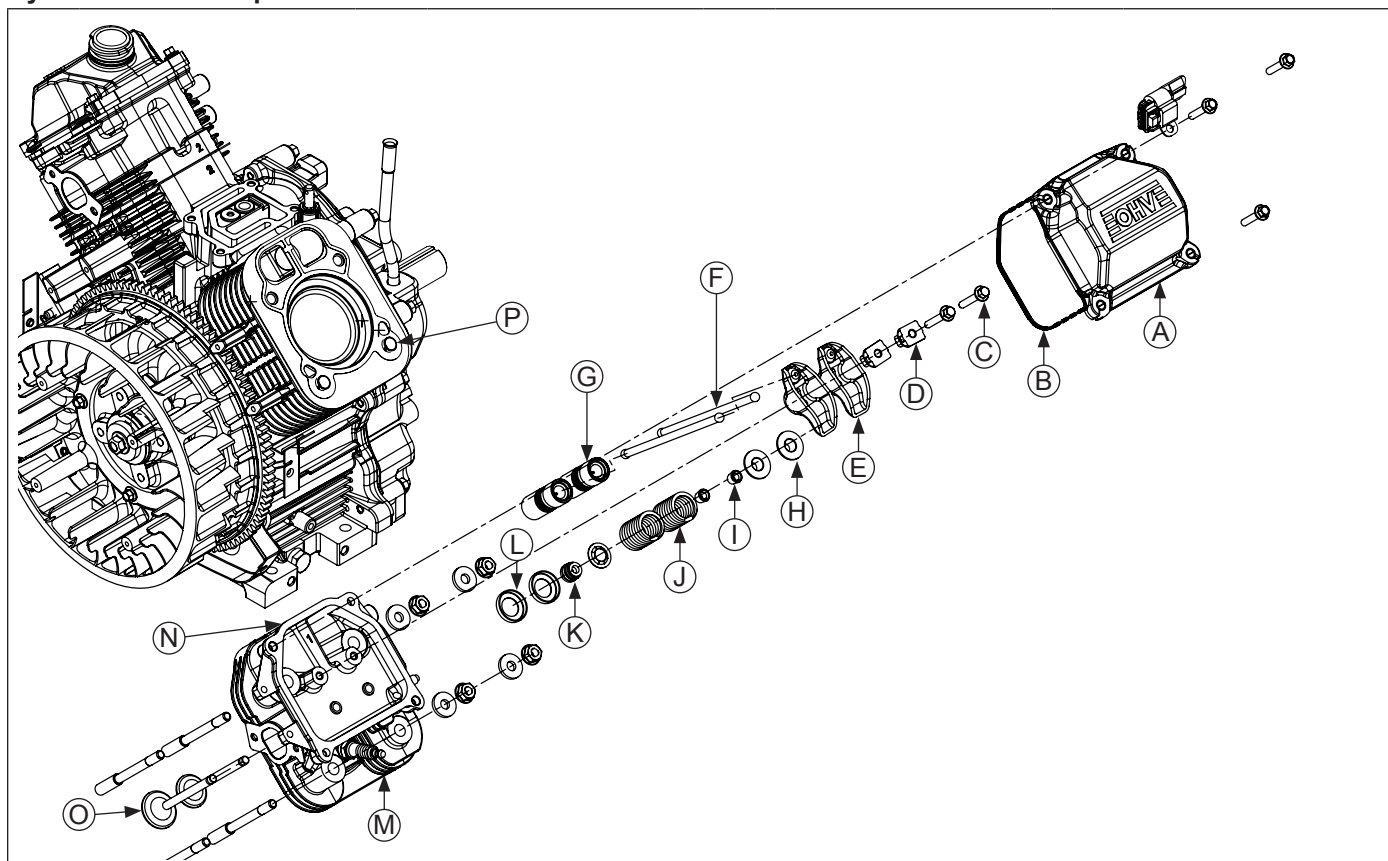

A	Valve Cover	B	Valve Cover Gasket	C	Hex Flange Screw	D	Rocker Arm Pivot
E	Rocker Arm	F	Push Rod	G	Hydraulic Lifter	H	Valve Cap
I	Valve Keeper	J	Valve Spring	K	Valve Seal	L	Valve Spring Retainer
M	Cylinder Head	N	Cylinder Head Gasket	O	Valve	P	Dowel Pin

Remove Valve Covers

1. Remove screws securing each valve cover. Note valve cover differences for proper location in reassembly. Ensure any brackets and clips/clamps removed are reassembled in same location.
2. Covers should lift off without prying.

Remove Spark Plugs

Remove spark plug from each cylinder head.

Remove Cylinder Heads and Hydraulic Lifters

NOTE: Cylinder heads are retained using either screws or nuts and washers on studs. Do not interchange or mix components.

1. Remove screws or nuts and washers securing each cylinder head. Discard screws or nuts and washers once removed. Do not reuse. Studs (if present) should only be removed if damaged or if cylinder reconditioning is necessary. Once removed, they must be replaced.
2. Mark location of push rods as either intake or exhaust and cylinder 1 or 2. Push rods should always be reinstalled in same positions.
3. Carefully remove push rods, cylinder heads, and head gaskets.
4. Remove lifters from lifter bores. Use a hydraulic lifter tool. Do not use a magnet to remove lifters. Mark lifters by location, as either intake or exhaust, and cylinder 1 or 2. Hydraulic lifters should always be reinstalled in same position.

Inspection

Check base surface of hydraulic lifters for wear or damage. If lifters need to be replaced, apply a liberal coating of Rehlko lubricant (see Tools and Aids) to base of each new lifter before it is installed.

Bleeding Lifters

To prevent a possible bent push rod or broken rocker arm, it is important to bleed any excess oil out of lifters before they are installed.

1. Cut a 50-75 mm (2-3 in.) piece from end of an old push rod and chuck it in a drill press.
2. Lay a rag or shop towel on table of drill press and place lifter, open end up, on towel.
3. Lower chucked push rod until it contacts plunger in lifter. Slowly pump plunger 2 or 3 times to force oil out of feed hole in side of lifter.

Disassemble Cylinder Heads

NOTE: These engines use valve stem seals on intake and exhaust valves. Use a new seal whenever valve is removed or if seal is deteriorated or damaged in any way. Never reuse an old seal.

1. Remove screws, rocker arm pivots and rocker arms from cylinder head. Note screw color for reassembly.
2. Compress valve springs using a valve spring compressor.
3. Once valve spring is compressed, remove valve spring keepers, then remove following items.
 - Valve spring retainers
 - Valve springs
 - Valve spring caps
 - Intake and exhaust valve (mark position)
 - Valve stem and seals (intake and exhaust)
4. Repeat above procedure for other cylinder head. Do not interchange parts from 1 cylinder head to other.

Inspection and Service

Valve Details

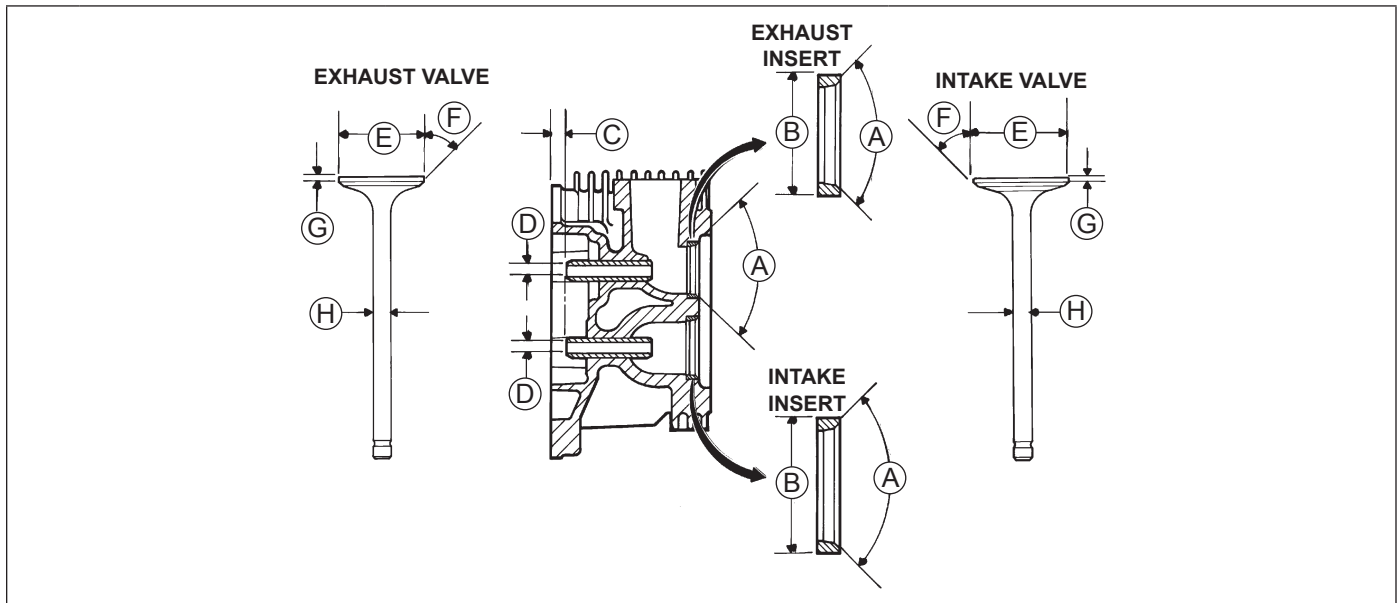

Dimension		Intake	Exhaust
A	Seat Angle	89°	89°
B	Insert O.D.	36.987/37.013 mm (1.4562/1.4572 in.)	32.987/33.013 mm (1.2987/1.2997 in.)
C	Guide Depth	4 mm (0.1575 in.)	4 mm (0.1575 in.)
D	Guide I.D.	7.038/7.058 mm (0.2771/0.2779 in.)	7.038/7.058 mm (0.2771/0.2779 in.)
E	Valve Head Diameter	33.37/33.63 mm (1.3138/1.3240 in.)	29.37/29.63 mm (1.1563/1.1665 in.)
F	Valve Face Angle	45°	45°
G	Valve Margin (Min.)	1.5 mm (0.0591 in.) 6.982/7.000 mm	1.5 mm (0.0591 in.)
H	Valve Stem Diameter	(0.2749/0.2756 in.)	6.970/6.988 mm (0.2744/0.2751 in.)

Disassembly/Inspection and Service

After cleaning, check flatness of cylinder head and corresponding top surface of crankcase, using a surface plate or precision straight edge and feeler gauge. Maximum allowable out of flatness is 0.076 mm (0.003 in.).

Carefully inspect valve mechanism parts. Inspect valve springs and related hardware for excessive wear or distortion. Check valves and valve seat area or inserts for evidence of deep pitting, cracks, or distortion. Check clearance of valve stems in guides. See valve details and specifications.

Hard starting or loss of power accompanied by high fuel consumption may be symptoms of faulty valves. Although these symptoms could also be attributed to worn rings, remove and check valves first. After removal, clean valve heads, faces, and stems with a power wire brush. Then, carefully inspect each valve for defects such as a warped head, excessive corrosion, or a worn stem end. Replace valves found to be in bad condition.

Valve Guides

If a valve guide is worn beyond specifications, it will not guide valve in a straight line. This may result in burnt valve faces or seats, loss of compression, and excessive oil consumption.

To check valve guide-to-valve stem clearance, thoroughly clean valve guide and, using a split-ball gauge, measure inside diameter of guide. Then, using an outside micrometer, measure diameter of valve stem at several points on stem where it moves in valve guide. Use largest stem diameter to calculate clearance by subtracting stem diameter from guide diameter. If intake clearance exceeds 0.038/0.076 mm (0.0015/0.0030 in.) or exhaust clearance exceeds 0.050/0.088 mm (0.0020/0.0035 in.), determine whether valve stem or guide is responsible for excessive clearance.

Maximum (I.D.) wear on intake valve guide is 7.134 mm (0.2809 in.) while 7.159 mm (0.2819 in.) is maximum allowed on exhaust guide. Guides are not removable but can be reamed 0.25 mm (0.010 in.) oversize. Valves with 0.25 mm oversize stems must then be used.

If guides are within limits but valve stems are worn beyond limits, install new valves.

Valve Seat Inserts

Hardened steel alloy intake and exhaust valve seat inserts are press fitted into cylinder head. Inserts are not replaceable but can be reconditioned if not too badly pitted or distorted. If cracked or badly warped, cylinder head should be replaced.

Recondition valve seat inserts following instructions provided with valve seat cutter being used. Final cut should be made with an 89° cutter as specified for valve seat angle. Cutting proper 45° valve face angle as specified, and proper valve seat angle (44.5°, half of full 89° angle), will achieve desired 0.5° (1.0° full cut) interference angle where maximum pressure occurs on outside diameters of valve face and seat.

Lapping Valves

NOTE: Exhaust valves that are black in color cannot be ground and do not require lapping.

Reground or new valves must be lapped in, to provide proper fit. Use a hand valve grinder with a suction cup for final lapping. Lightly coat valve face with a fine grade of grinding compound, then rotate valve on its seat with grinder. Continue grinding until a smooth surface is obtained on seat and on valve face. Thoroughly clean cylinder head in soap and hot water to remove all traces of grinding compound. After drying cylinder head, apply a light coating of SAE 10 oil to prevent rusting.

Valve Stem Seal

These engines use valve stem seals on intake and exhaust valves. Always use a new seal when valves are removed from cylinder head. Seals should also be replaced if deteriorated or damaged in any way. Never reuse an old seal.

Flywheel Components

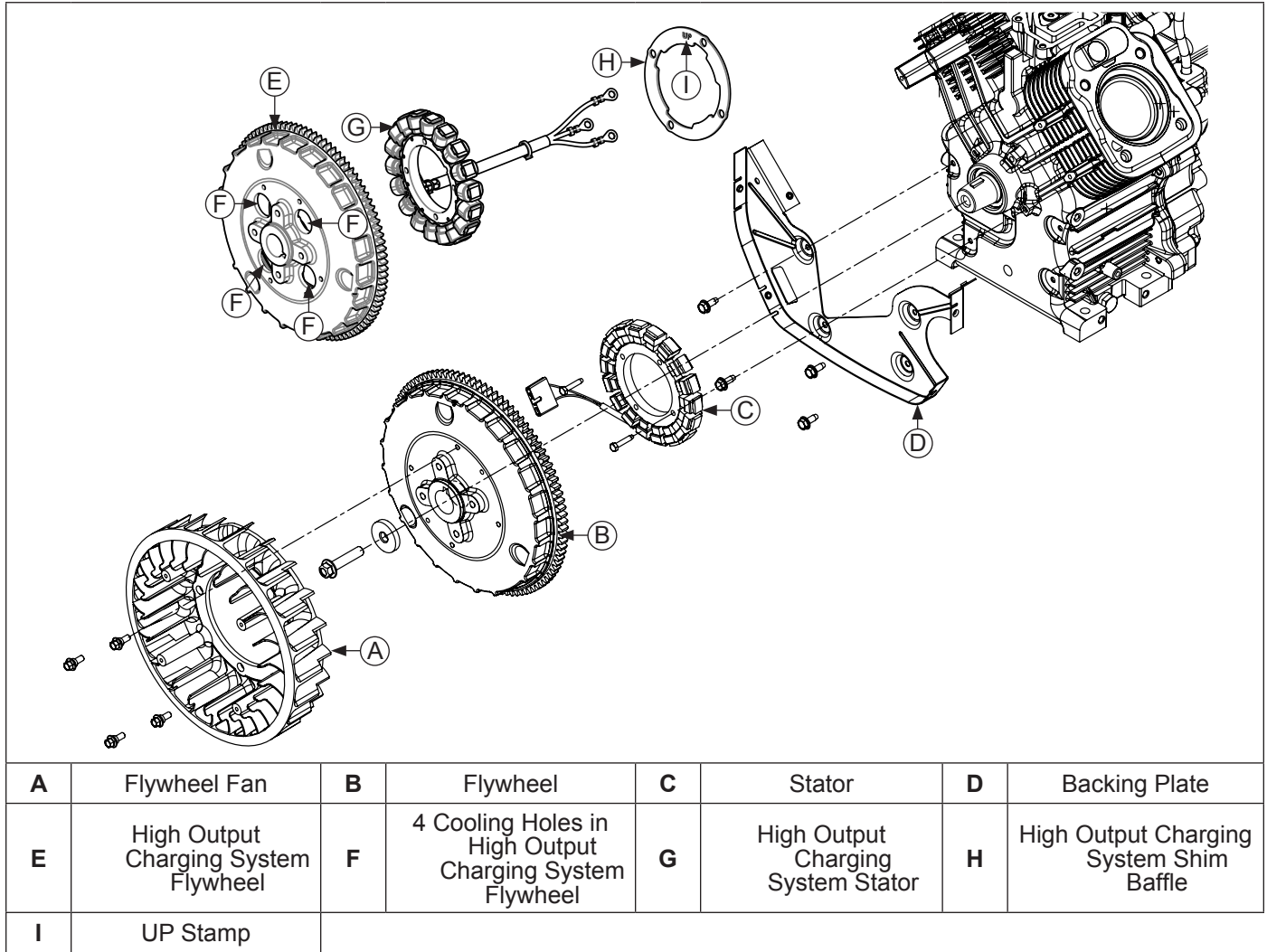

Remove Fan and Flywheel

NOTE: Always use a flywheel strap wrench or holding tool to hold flywheel when loosening or tightening flywheel screw. Do not use any type of bar or wedge to hold flywheel. Use of such tools could cause flywheel to become cracked or damaged.

NOTE: Always use a flywheel puller to remove flywheel from crankshaft. Do not strike crankshaft or flywheel, as these parts could become cracked or damaged. Striking puller or crankshaft can cause crank gear to move, affecting crankshaft endplay.

NOTE: High output charging system flywheel (identified by 4 large cooling holes) has very strong magnets. Magnet assembly guard on interior of this flywheel has a thin, sharp edge. Wear protective gloves when handling this flywheel.

1. Remove shoulder bolts securing fan if still attached and remove fan.
2. Use a flywheel strap wrench or holding tool (see Tools and Aids) to hold flywheel and loosen screw securing flywheel to crankshaft.
3. Remove screw and washer.
4. Use a flywheel puller to remove flywheel from crankshaft. ETB ECH EFI engines with high output charging system have a flywheel with very strong magnets. Wear protective gloves and use a flywheel puller to remove this flywheel.
5. Remove woodruff key.

Disassembly/Inspection and Service

Inspection

Inspect flywheel for cracks and flywheel keyway for damage. Replace flywheel if it is cracked. Replace flywheel, crankshaft, and key if flywheel key is sheared or keyway is damaged.

Inspect ring gear for cracks or damage. Rehlko does not provide ring gear as a serviceable part. Replace flywheel if ring gear is damaged.

Remove Stator and Backing Plate (ETB ECH EFI & ECH EFI)

1. Remove screws securing backing plate. Remove backing plate.
2. Remove screws and stator. Note position/routing of stator lead.
3. On ETB ECH EFI engines with high output charging system, note position of UP stamp on shim baffle for reassembly; remove shim baffle.

Remove Closure Plate Assembly

1. Remove screws securing closure plate to crankcase.
2. Locate splitting tabs cast into perimeter of closure plate. Insert drive end of a 1/2 in. breaker bar between splitting tab and crankcase and turn it to loosen seal. Do not pry on sealing surfaces as this can cause leaks.

Inspection

Inspect oil seal in closure plate and remove it if it is worn or damaged. Refer to Install Closure Plate Oil Seal in Reassembly for new oil seal installation.

Inspect main bearing surface for wear or damage (refer to Specifications). Replace closure plate assembly if required.

Governor Gear Assembly (if equipped)

Governor Shaft Press Depth Details

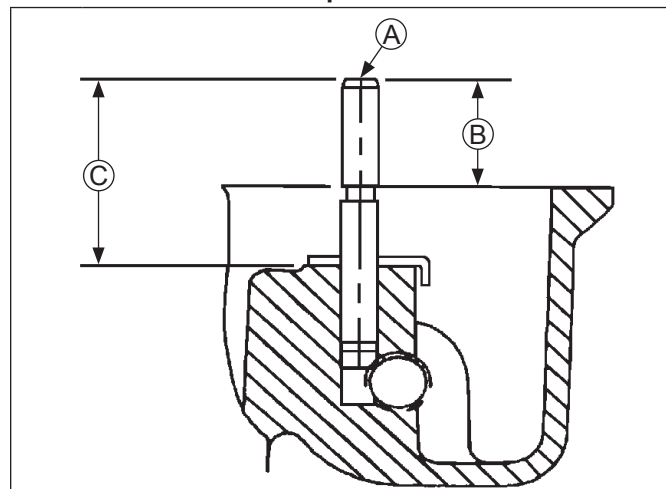

A	Gear Shaft
B	19.40 mm (0.7638 in.)
C	34.0 mm (1.3386 in.) 33.5 mm (1.3189 in.)

Governor gear assembly is located inside closure plate. If service is required, continue with Inspection, Disassembly, and Reassembly.

Inspection

Inspect governor gear teeth. Replace gear if it is worn, chipped, or if any teeth are missing. Inspect governor weights. They should move freely in governor gear.

Disassembly

NOTE: Governor gear is held onto shaft by small molded tabs in gear. When gear is removed from shaft, these tabs are destroyed and gear must be replaced. Therefore, remove gear only if absolutely necessary.

Governor gear must be replaced once it is removed from closure plate.

1. Remove regulating pin and governor gear assembly.
2. Remove locking tab thrust washer located under governor gear assembly.
3. Carefully inspect governor gear shaft and replace it only if it is damaged. After removing damaged shaft, press or lightly tap replacement shaft into closure plate to depth shown.

Reassembly

1. Install locking tab thrust washer on governor gear shaft with tab down.
2. Position regulating pin within governor gear/flyweight assembly and slide both onto governor shaft.

Oil Pump Assembly (Style A)

Oil Pump (Style A) Torque Sequence

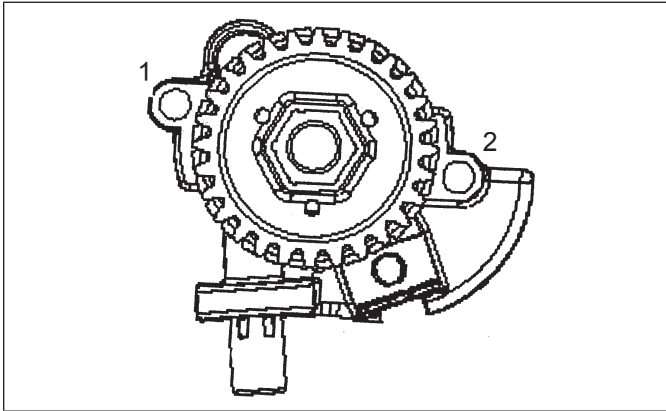

Oil pump is mounted inside closure plate. If service is required, continue with Disassembly, Inspection, and Reassembly.

Disassembly

1. Remove screws.
2. Remove oil pump assembly from closure plate.
3. Remove oil pump rotor. Unhook locking clip, and care fully pull it free from oil pump housing.

Relief valve is a one-piece style, staked to oil pump housing. Removal should not be attempted, nor is internal servicing possible. If a problem with relief valve is encountered, oil pump should be replaced.

Inspection

Inspect oil pump housing, gear, and rotors for nicks, burrs, wear, or any visible damage. If any parts are worn or damaged, replace oil pump.

Reassembly

1. Install oil pickup to oil pump body. Lubricate O-ring with oil and make sure it remains in groove as pickup is being installed.
2. Install rotor.
3. Install oil pump body to closure plate and secure with screws. Torque screws as follows:
 - a. Install fastener into location 1 and lightly tighten to position pump.
 - b. Install fastener into location 2 and fully torque to recommended value.
 - c. Torque fastener in location 1 to recommended value.

First Time Installation: 10.7 N·m (95 in. lb.)
All Reinstallations: 6.7 N·m (60 in. lb.)
4. After torquing, rotate gear and check for freedom of movement. Make sure there is no binding. If binding occurs, loosen screws, reposition pump, retorque screws and recheck movement.

Oil Pump Assembly (Style B)

Oil pump is mounted inside closure plate. If service is required, continue with Disassembly, Inspection, and Reassembly.

Disassembly

1. Remove screws.
2. Lift oil pump assembly from closure plate. Remove outer gerotor gear from closure plate.
3. Ensure ball and spring remain installed in pressure relief hole of closure plate. If ball and spring fall out of pressure relief hole, see reassembly for correct installation.
4. Remove oil pump cover O-ring from groove in closure plate.

Inspection

Inspect oil pump housing, gear, and rotors for nicks, burrs, wear, or any visible damage. Inspect oil pump cover O-ring for cuts, nicks, or any visible damage. If any parts are worn or damaged, replace oil pump assembly and/or O-ring. Check oil pickup screen for damage or restriction, replace if necessary.

Reassembly

1. Lubricate outer gerotor gear with oil. Install outer gerotor gear through shaft of oil pump, around inner gerotor gear. Matching molding dots on inner and outer gerotor gears is not necessary and will not affect oil pump efficiency.
2. Reinstall ball, then spring into pressure relief hole in closure plate.
3. Reinstall O-ring into groove in closure plate; make sure it is fully seated in groove.
4. Install oil pump inserting center shaft into corresponding recess in closure plate. Apply consistent downward pressure to oil pump cover, compressing oil pressure relief spring and start screws. Secure oil pump by torquing screws (in no specific sequence) to 9.0 N·m (80 in. lb.).
5. After torquing, rotate gear and check for freedom of movement. Make sure there is no binding. If binding occurs, loosen screws, reposition pump, retorque screws and recheck movement.

Disassembly/Inspection and Service

Crankcase Components

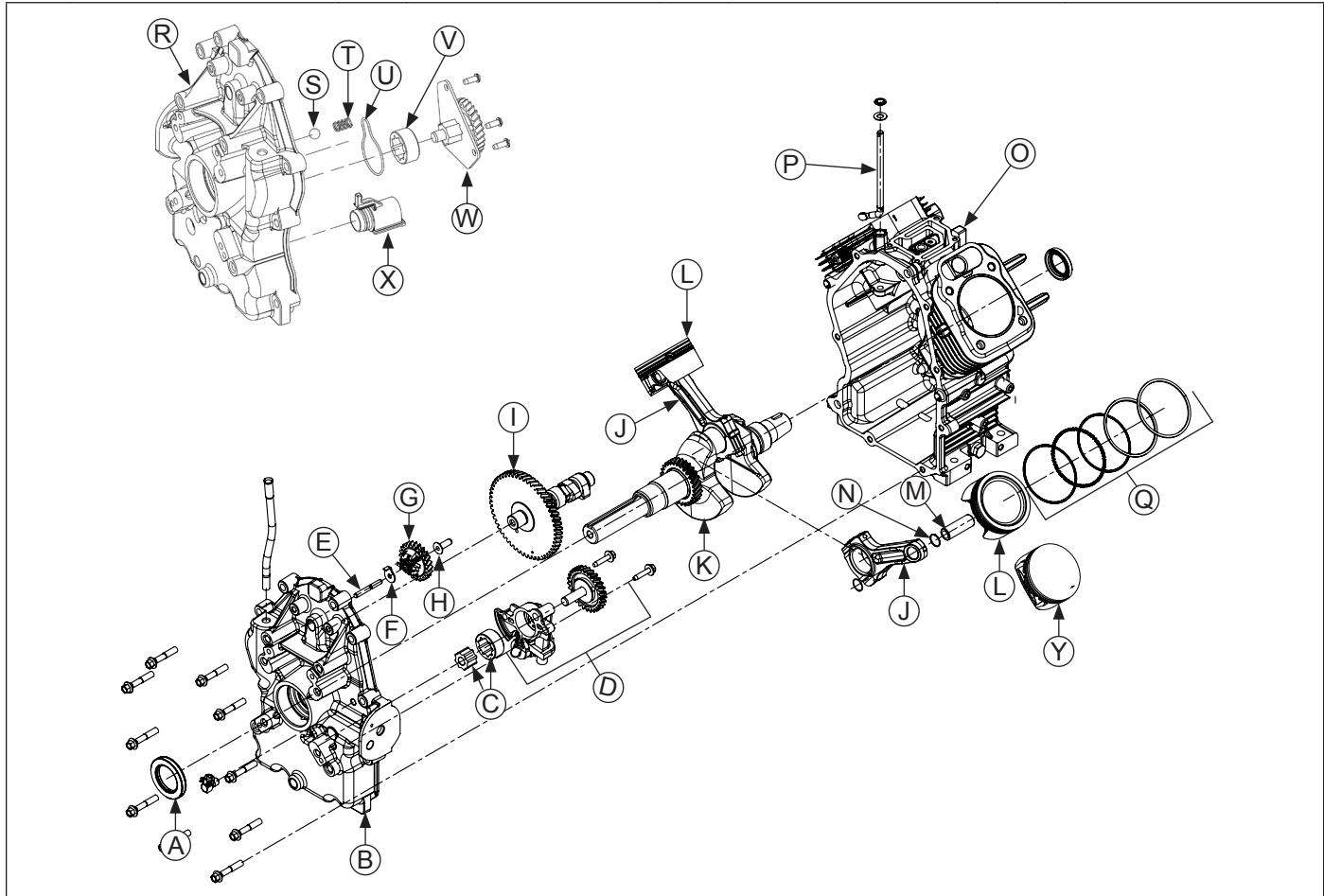

A	Closure Plate Seal	B	Closure Plate (Style A)	C	Gerotor Gears (Style A)	D	Oil Pump Assembly (Style A)
E	Governor Shaft	F	Governor Washer	G	Governor Gear	H	Governor Cup
I	Camshaft	J	Connecting Rod	K	Crankshaft	L	Piston (Style B)
M	Piston Pin	N	Piston Pin Retainer Clip	O	Crankcase	P	Governor Cross Shaft
Q	Piston Rings	R	Closure Plate (Style B)	S	Ball (Style B)	T	Spring (Style B)
U	Oil Pump Cover O-ring (Style B)	V	Outer Gerotor Gear (Style B)	W	Oil Pump Assembly (Style B)	X	Oil Pick-Up Tube (Style B)
Y	Piston (Style A)						

Remove Camshaft

Remove camshaft.

Inspection and Service

NOTE: To prevent repeat failures, camshaft and crankshaft should always be replaced as a set.

Check lobes of camshaft for wear or damage. See Specifications for minimum lift tolerances. Measurement must be performed while valve train is still assembled. Inspect cam gear for badly worn, chipped or missing teeth. Replacement of camshaft will be necessary if any of these conditions exist.

Remove Governor Cross Shaft (if equipped)

1. Remove retainer and nylon washer, from governor cross shaft.
2. Remove cross shaft through inside of crankcase.

Governor Cross Shaft Oil Seal (if equipped)

Cross Shaft Oil Seal Details

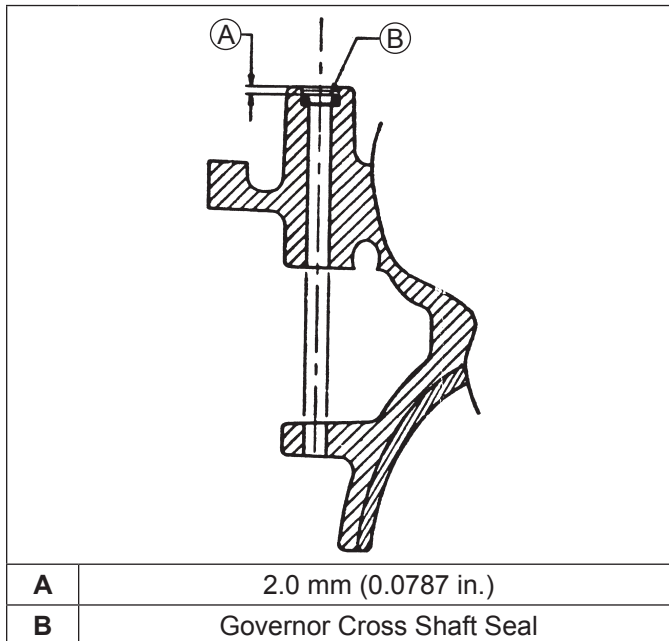

If governor cross shaft seal is damaged and/or leaks, replace it using these following procedures.

Remove oil seal from crankcase and replace it with a new one. Lightly coat outer diameter of governor cross shaft seal with P80 Emulsion Lubricant (refer to Tools and Aids). Install new seal to depth shown using a seal installer.

Remove Connecting Rods with Pistons and Rings

NOTE: If a carbon ridge is present at top of either cylinder bore, use a ridge reamer tool to remove it before attempting to remove piston.

NOTE: Cylinders are numbered on crankcase. Use numbers to mark each end cap, connecting rod and piston for reassembly. Do not mix end caps and connecting rods.

1. Remove screws securing closest connecting rod end cap. Remove end cap.
2. Carefully remove connecting rod and piston assembly from cylinder bore.
3. Repeat above procedure for other connecting rod and piston assembly.
4. Remove piston pin from piston for inspection. Use a small screwdriver to pry pin retainer out of groove.

Piston and Rings

Inspection

Piston and Rings Components and Details

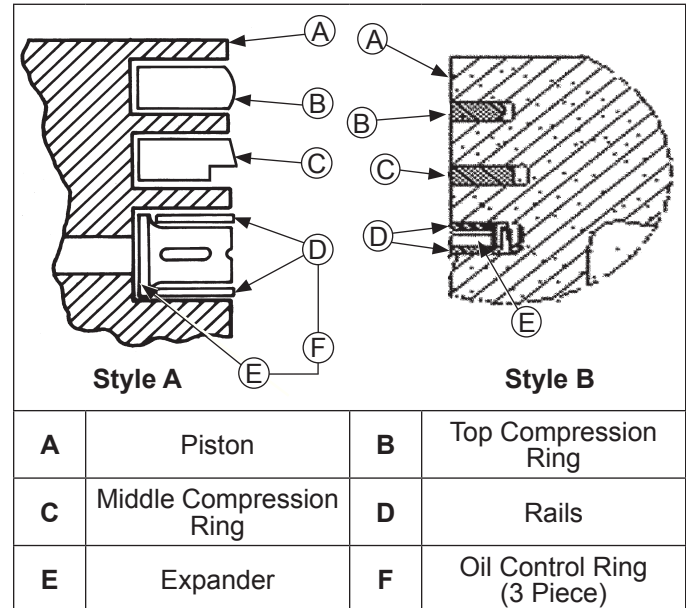

NOTE: Rings must be installed correctly. Ring installation instructions are usually included with new ring sets. Follow instructions carefully. Use a piston ring expander to install rings. Install bottom (oil control) ring first and top compression ring last.

Scuffing and scoring of pistons and cylinder walls occurs when internal engine temperatures approach welding point of piston. Temperatures high enough to do this are created by friction, which is usually attributed to improper lubrication and/or overheating of engine.

Normally, very little wear takes place in piston boss-piston pin area. If original piston and connecting rod can be reused after new rings are installed, original pin can also be reused but new piston pin retainers are required. Piston pin is included as part of piston assembly – if pin boss in piston or pin are worn or damaged, a new piston assembly is required.

Ring failure is usually indicated by excessive oil consumption and blue exhaust smoke. When rings fail, oil is allowed to enter combustion chamber where it is burned along with fuel. High oil consumption can also occur when piston ring end gap is incorrect because ring cannot properly conform to cylinder wall under this condition. Oil control is also lost when ring gaps are not staggered during installation.

When cylinder temperatures get too high, lacquer and varnish collect on pistons causing rings to stick, which results in rapid wear. A worn ring usually takes on a shiny or bright appearance.

Scratches on rings and pistons are caused by abrasive material such as carbon, dirt, or pieces of hard metal.

Detonation damage occurs when a portion of fuel charge ignites spontaneously from heat and pressure shortly after ignition. This creates 2 flame fronts which meet and explode to create extreme hammering pressures on a

Disassembly/Inspection and Service

specific area of piston. Detonation generally occurs from using low octane fuels.

Preignition or ignition of fuel charge before timed spark can cause damage similar to detonation. Preignition damage is often more severe than detonation damage. Preignition is caused by a hot spot in combustion chamber from sources such as glowing carbon deposits, blocked cooling fins, an improperly seated valve, or wrong spark plug(s).

Replacement pistons are available in STD bore size, and in 0.25 mm (0.010 in.), and 0.50 mm (0.020 in.) oversize. Replacement pistons include new piston ring sets and new piston pins.

Replacement ring sets are also available separately for STD, 0.25 mm (0.010 in.), and 0.50 mm (0.020 in.) oversize pistons. Always use new piston rings when installing pistons. Never use old rings.

Some important points to remember when servicing piston rings:

Piston Style A

1. Cylinder bore must be de-glazed before service ring sets are used.
2. If cylinder bore does not need re-boring and if old piston is within wear limits and free of score or scuff marks, old piston may be reused.
3. Remove old rings and clean up grooves. Never reuse old rings.
4. Before installing new rings on piston, place top 2 rings, each in turn, in its running area in cylinder bore and check end gap. Top and center compression ring end gap clearance is 0.25/0.56 mm (0.010/0.022 in.) with maximum wear limit of 0.94 mm (0.037 in.).
5. After installing new compression (top and middle) rings on piston, check side clearance. If side clearance is greater than specified, a new piston must be used.

Model ECH630-749 engines: Top compression ring-to-groove side clearance is 0.050/0.095 mm (0.0019/0.0037 in.). Middle compression ring-to-groove side clearance is 0.030/0.075 mm (0.0012/0.00307 in.).

Model CH26, CH735, CH745 engines: Top compression ring-to-groove side clearance is 0.025/0.048 mm (0.0010/0.0019 in.). Middle compression ring-to-groove side clearance is 0.015/0.037 mm (0.0006/0.0015 in.).

Piston Style B

1. Cylinder bore must be de-glazed before service ring sets are used.
2. If cylinder bore does not need re-boring and if old piston is within wear limits and free of score or scuff marks, old piston may be reused.
3. Remove old rings and clean up grooves. Never reuse old rings.
4. Before installing new rings on piston, place top 2 rings, each in turn, in its running area in cylinder bore and check end gap.

80 mm bore engines: Top compression ring end gap is 0.100/0.279 mm (0.0039/0.0110 in.). Middle compression ring end gap is 1.400/1.679 mm (0.0551/0.0661 in.).

83 mm bore engines: Top compression ring end gap is 0.189/0.277 mm (0.0074/0.0109 in.). Middle compression ring end gap is 1.519/1.797 mm (0.0598/0.0708 in.).

5. After installing new compression (top and middle) rings on piston, make sure ring-to-groove side clearance is 0.030/0.070 mm (0.001/0.0026 in.). If side clearance is greater than specified, a new piston must be used.

Install New Piston Rings

Piston Ring Orientation

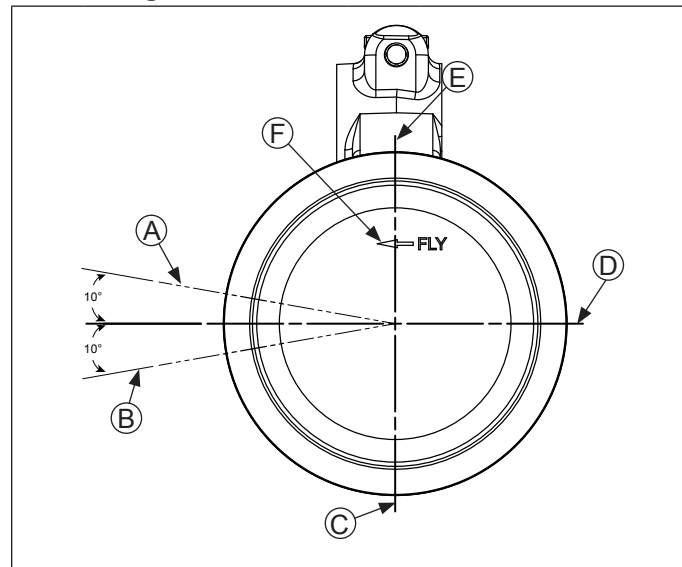

A	Top Oil Ring Rail Gap	B	Bottom Oil Ring Rail Gap
C	Middle Ring Gap	D	Oil Ring Expander Gap
E	Top Ring Gap	F	FLY Stamp

NOTE: Rings must be installed correctly. Ring installation instructions are usually included with new ring sets. Follow instructions carefully. Use a piston ring expander to install rings. Install bottom (oil control) ring first and top compression ring last.

To install new piston rings, proceed as follows:

1. Oil control ring (bottom groove): Install expander and then rails. Make sure ends of expander are not overlapped.
2. Middle compression ring (center groove): Install center ring using a piston ring installation tool. Make sure identification mark is up or colored dye stripe (if contained), is to left of end gap.
3. Top compression ring (top groove): Install top ring using a piston ring expander. Make sure identification mark is up or colored dye stripe (if contained), is to left of end gap.

Connecting Rods

Offset, stepped-cap connecting rods are used in all these engines.

Inspection and Service

Check bearing area (big end) for excessive wear, score marks, running and side clearances (refer to Specifications). Replace rod and cap if scored or excessively worn.

Service replacement connecting rods are available in STD crankpin size and 0.25 mm (0.010 in.) undersize. 0.25 mm (0.010 in.) undersized rod can be identified by drilled hole located in lower end of rod shank. Always refer to appropriate parts information to ensure correct replacements are used.

Remove Crankshaft

Carefully pull crankshaft from crankcase.

Inspection and Service

Crankshaft Components and Details

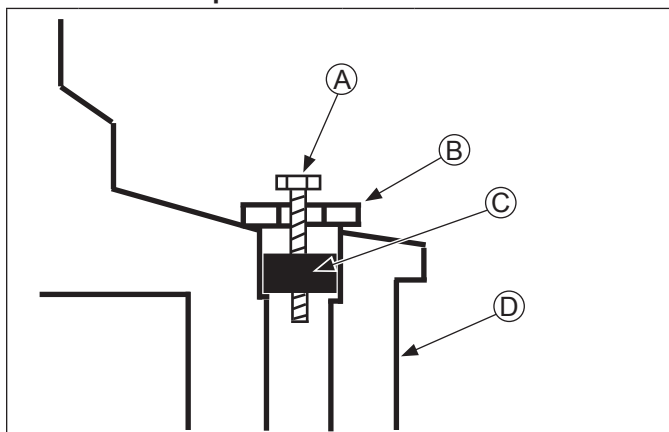

A	Self-Tapping Screw	B	Flat Washer
C	Plug	D	Crankshaft

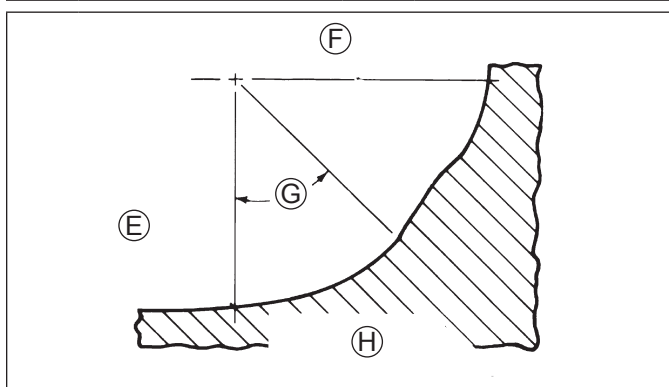

E	Fillet Must Blend Smoothly with Bearing Journal Surface
F	High Point from Fillet Intersections
G	45° Minimum
H	This Fillet Area Must Be Completely Smooth

NOTE: If crankpin is reground, visually check to ensure fillet blends smoothly with crankpin surface.

NOTE: To prevent repeat failures, camshaft and crankshaft should always be replaced as a set.

Inspect gear teeth of crankshaft. If teeth are badly worn, chipped, or some are missing, replacement of crankshaft will be necessary.

Inspect crankshaft bearing surfaces for scoring, grooving, etc. Some engines have bearing inserts in crankshaft bore of closure plate and/or crankcase. Do not replace bearings unless they show signs of damage or are out of running clearance specifications. If crankshaft turns easily and noiselessly, and there is no evidence of scoring, grooving, etc., on races or bearing surfaces, bearings can be reused.

Inspect crankshaft keyways. If they are worn or chipped, replacement of crankshaft will be necessary.

Inspect crankpin for score marks or metallic pickup. Slight score marks can be cleaned with crocus cloth soaked in oil. If wear limits, as stated in Specifications and Tolerances are exceeded, it will be necessary to either replace crankshaft or regrind crankpin to 0.25 mm (0.010 in.) undersize. If reground, a 0.25 mm (0.010 in.) undersize connecting rod (big end) must then be used to achieve proper running clearance. Measure crankpin for size, taper, and out-of-round.

Connecting rod journal can be ground one size under. When grinding a crankshaft, grinding stone deposits can get caught in oil passages, which could cause severe engine damage. Removing crankpin plug when crankshaft is ground provides easy access for removing any grinding deposits collected in oil passages.

Use these following procedures to remove and replace plug.

Procedure to Remove Crankshaft Plug:

1. Drill a 3/16 in. hole through plug in crankshaft.
2. Thread a 3/4 in. or 1 in. long self-tapping screw with a flat washer into drilled hole. Flat washer must be large enough to seat against shoulder of plug bore.
3. Tighten self-tapping screw until it draws plug out of crankshaft.

Procedure to Install New Plug:

Use a single cylinder camshaft pin as a driver and tap plug into plug bore until it seats at bottom of bore. Make sure plug is tapped in evenly to prevent leakage.

Remove Flywheel End Oil Seal

Remove oil seal from crankcase.

Disassembly/Inspection and Service

Crankcase

Inspection and Service

Check all gasket surfaces to make sure they are free of gasket fragments. Gasket surfaces must also be free of deep scratches or nicks.

Inspect main bearing (if so equipped) for wear or damage (refer to Specifications). Replace crankcase using a miniblock or short block as required.

Check cylinder bore wall for scoring. In severe cases, unburned fuel can cause scuffing and scoring of cylinder wall. It washes necessary lubricating oils off piston and cylinder wall. As raw fuel seeps down cylinder wall, piston rings make metal to metal contact with wall. Scoring of cylinder wall can also be caused by localized hot spots resulting from blocked cooling fins or from inadequate or contaminated lubrication.

If cylinder bore is badly scored, excessively worn, tapered, or out-of-round, resizing is necessary. Use an inside micrometer to determine amount of wear (refer to Specifications), then select nearest suitable oversize of either 0.25 mm (0.010 in.) or 0.50 mm (0.020 in.). Resizing to one of these oversizes will allow usage of available oversize piston and ring assemblies. First, resize using a boring bar, then use these following procedures for honing cylinder.

Honing

Detail

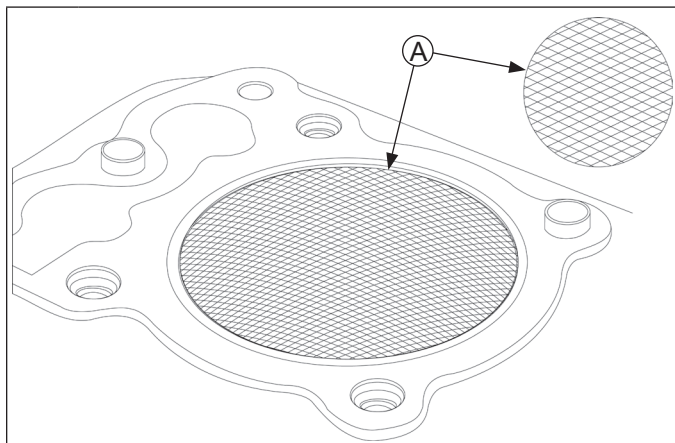

A 23°-33° Crosshatch

NOTE: Rehlko pistons are custom-machined to exacting tolerances. When oversizing a cylinder, it should be machined exactly 0.25 mm (0.010 in.) or 0.50 mm (0.020 in.) over new diameter (Specifications). Corresponding oversize Rehlko replacement piston will then fit correctly.

While most commercially available cylinder hones can be used with either portable drills or drill presses, use of a low speed drill press is preferred as it facilitates more accurate alignment of bore in relation to crankshaft crossbore. Honing is best accomplished at a drill speed of about 250 RPM and 60 strokes per minute. After installing coarse stones in hone, proceed as follows:

1. Lower hone into bore and after centering, adjust so stones are in contact with cylinder wall. Use of a commercial cutting-cooling agent is recommended.

2. With lower edge of each stone positioned even with lowest edge of bore, start drill and honing process. Move hone up and down while resizing to prevent formation of cutting ridges. Check size frequently.
3. When bore is within 0.064 mm (0.0025 in.) of desired size, remove coarse stones and replace them with burnishing stones. Continue with burnishing stones until bore is within 0.013 mm (0.0005 in.) of desired size and then use finish stones (220-280 grit) and polish bore to its final size. A crosshatch should be observed if honing is done correctly. Crosshatch should intersect at approximately 23°-33° off horizontal. Too flat an angle could cause rings to skip and wear excessively, and too steep an angle will result in high oil consumption.
4. After resizing, check bore for roundness, taper, and size. Use an inside micrometer, telescoping gauge, or bore gauge to take measurements. These measurements should be taken at 3 locations in cylinder – at top, middle, and bottom. Two measurements should be taken (perpendicular to each other) at each location.

Clean Cylinder Bore After Honing

Proper cleaning of cylinder walls following boring and/or honing is very critical to a successful overhaul. Machining grit left in cylinder bore can destroy an engine in less than 1 hour of operation after a rebuild.

Final cleaning operation should always be a thorough scrubbing with a brush and hot, soapy water. Use a strong detergent capable of breaking down machining oil while maintaining a good level of suds. If suds break down during cleaning, discard dirty water and start again with more hot water and detergent. Following scrubbing, rinse cylinder with very hot, clear water, dry it completely, and apply a light coating of engine oil to prevent rusting.

Measuring Piston-to-Bore Clearance

Piston Detail

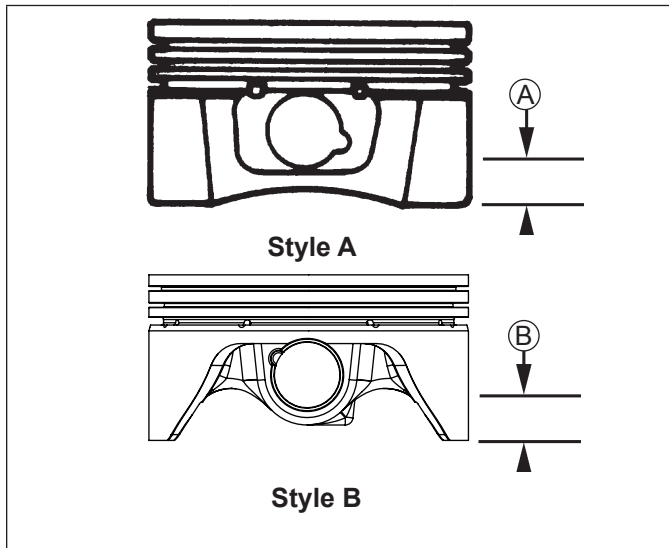

Model	Dimension A	Dimension B
ECH630-ECH680	6 mm (0.2362 in.)	13 mm (0.5118 in.)
ECH730-ECH749	6 mm (0.2362 in.)	6 mm (0.2362 in.)
CH26/CH735/ CH745	6 mm (0.2362 in.)	6 mm (0.2362 in.)

NOTE: Do not use a feeler gauge to measure piston-to-bore clearance – it will yield inaccurate measurements. Always use a micrometer.

Before installing piston into cylinder bore, it is necessary clearance be accurately checked. This step is often overlooked, and if clearances are not within specifications, engine failure will usually result.

Use following procedure to accurately measure piston-to-bore clearance:

1. Use a micrometer and measure diameter of piston above bottom of piston skirt and perpendicular to piston pin.
2. Use an inside micrometer, telescoping gauge, or bore gauge and measure cylinder bore. Take measurement approximately 63.5 mm (2.5 in.) below top of bore and perpendicular to piston pin.
3. Piston-to-bore clearance is difference between bore diameter and piston diameter (step 2 minus step 1).

Reassembly

Crankcase Components

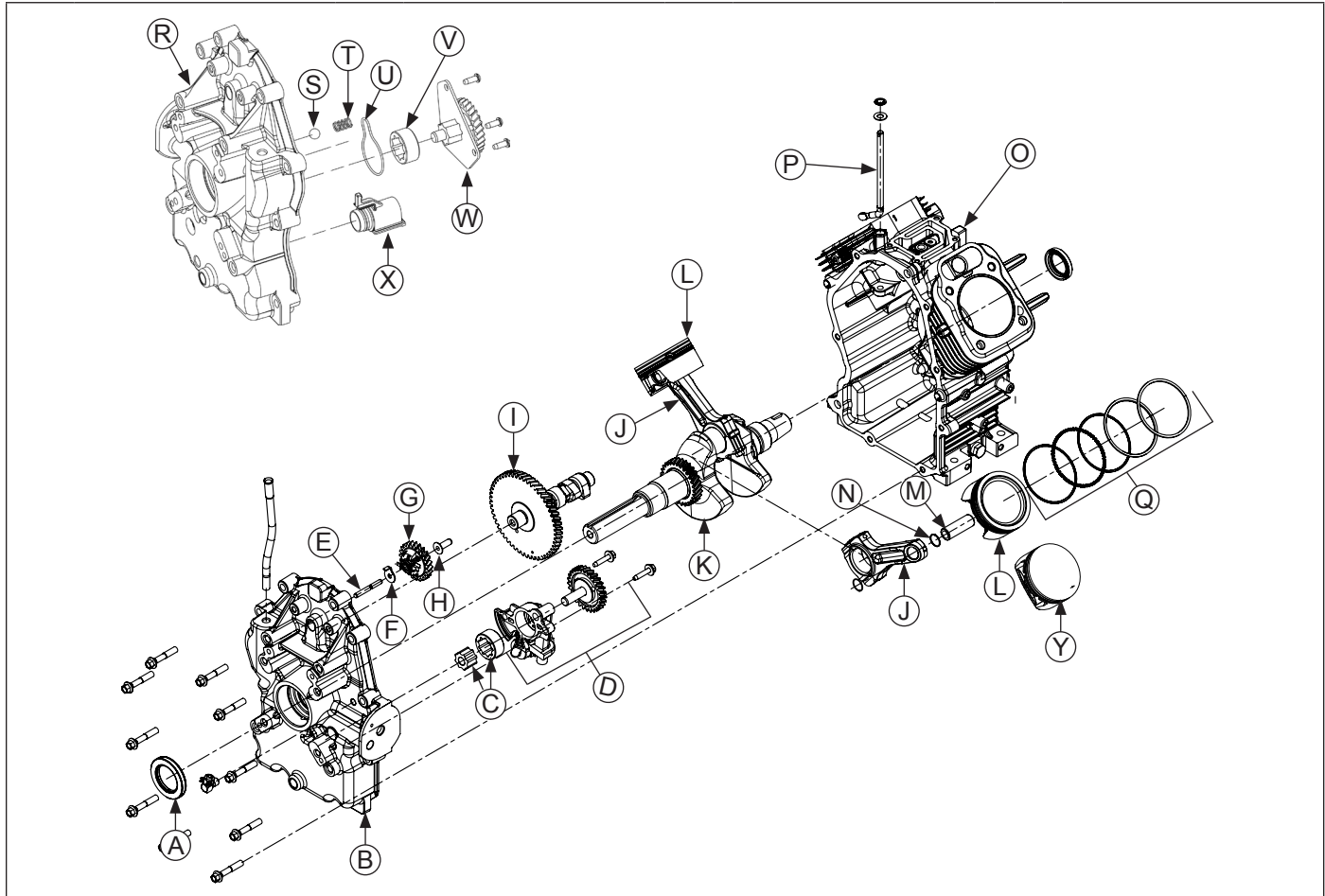

A	Closure Plate Seal	B	Closure Plate (Style A)	C	Gerotor Gears (Style A)	D	Oil Pump Assembly (Style A)
E	Governor Shaft	F	Governor Washer	G	Governor Gear	H	Governor Cup
I	Camshaft	J	Connecting Rod	K	Crankshaft	L	Piston (Style B)
M	Piston Pin	N	Piston Pin Retainer Clip	O	Crankcase	P	Governor Cross Shaft
Q	Piston Rings	R	Closure Plate (Style B)	S	Ball (Style B)	T	Spring (Style B)
U	Oil Pump Cover O-ring (Style B)	V	Outer Gerotor Gear (Style B)	W	Oil Pump Assembly (Style B)	X	Oil Pick-Up Tube (Style B)
Y	Piston (Style A)						

NOTE: Make sure engine is assembled using all specified torque values, tightening sequences and clearances. Failure to observe specifications could cause severe engine wear or damage. Always use new gaskets. Apply a small amount of oil to threads of critical fasteners before assembly, unless a Sealant or Loctite® is specified or preapplied.

Make sure all traces of any cleaner are removed before engine is assembled and placed into operation. Even small amounts of these cleaners can quickly break down lubricating properties of engine oil.

Check closure plate, crankcase, cylinder heads, to be certain all old sealing material has been removed. Use gasket remover, lacquer thinner, or paint remover to remove any remaining traces. Clean surfaces with isopropyl alcohol, acetone, lacquer thinner, or electrical contact cleaner.

Install Flywheel End Oil Seal

Oil Seal Detail

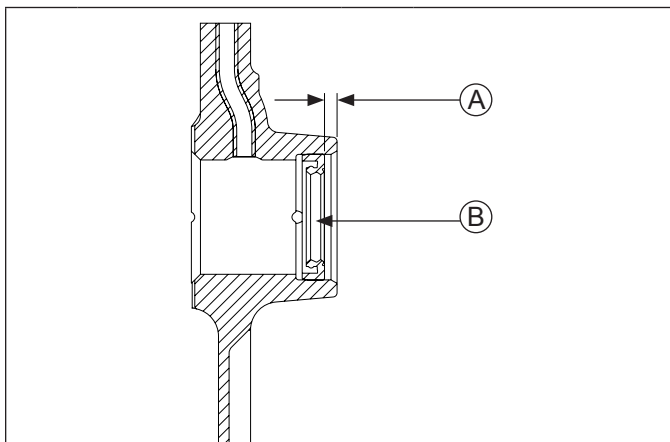

A	4.5 mm (0.177 in.)	B	Oil Seal
----------	--------------------	----------	----------

1. Make sure seal bore of crankcase is clean and free of any nicks or burrs.
2. Apply a light coat of P80 Emulsion Lubricant (refer to Tools and Aids) to outside diameter of oil seal.
3. Drive oil seal into crankcase using a seal driver. Make sure oil seal is installed straight and true in bore to depth shown.

Install Crankshaft

1. Lubricate crankshaft journals and connecting rod bearing surfaces with engine oil.
2. Carefully slide flywheel end of crankshaft through main bearing in crankcase.

Install Connecting Rods with Pistons and Rings

Piston Detail

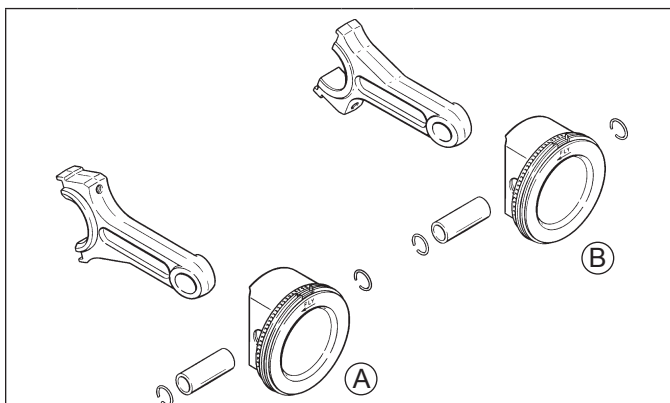

A	Cylinder 1	B	Cylinder 2
----------	------------	----------	------------

NOTE: Cylinders are numbered on crankcase. Make sure to install piston, connecting rod and end cap into its appropriate cylinder bore as previously marked at disassembly. Do not mix end caps and connecting rods.

NOTE: Proper orientation of piston/connecting rod assemblies inside engine is extremely important. Improper orientation can cause extensive wear or damage. Be certain pistons and connecting rods are assembled exactly as shown.

NOTE: Align chamfer of connecting rod with chamfer of its mating end cap. When installed, flat faces of connecting rods should face each other. Faces with raised rib should be toward outside.

1. If piston rings were removed, see Disassembly/ Inspection and Service procedure to install rings.
2. Lubricate cylinder bore, piston, and piston rings with engine oil. Compress rings of cylinder 1 piston using a piston ring compressor.
3. Make sure FLY stamping on piston is facing towards flywheel side of engine. Use a hammer with a rubber grip and gently tap piston into cylinder. Be careful oil ring rails do not spring free between bottom of ring compressor and top of cylinder.
4. Install inner rod cap to connecting rod using screws. Different types of connecting rod bolts have been used and each has a different torque value.

If 8 mm straight shank type bolts are used, torque in increments to 22.7 N·m (200 in. lb.). If 8 mm stepdown bolts are used, torque in increments to 14.7 N·m (130 in. lb.).

If 6 mm with black coating, torque in increments to 11.3 N·m (100 in. lb.). If 6 mm with gray metallic coating, it is not necessary to lubricate this screw, torque in increments to 13.6 N·m (120 in. lb.).

5. Repeat above procedure for other connecting rod and piston assembly.

Install Governor Cross Shaft (if equipped)

1. Lubricate governor cross shaft bearing surfaces in crankcase with engine oil.
2. Slide small lower washer onto governor cross shaft and install cross shaft from inside of crankcase.
3. Install nylon washer onto governor cross shaft, then start push-on retaining ring. Hold cross shaft up in position, place a 0.50 mm (0.020 in.) feeler gauge on top of nylon washer, and push retaining ring down shaft to secure. Remove feeler gauge, which will have established proper end play.

Install Camshaft

1. Liberally apply camshaft lubricant (see Tools and Aids) to each cam lobe. Lubricate camshaft bearing surfaces of crankcase and camshaft with engine oil.
2. Position timing mark of crankshaft gear at 12 o'clock position.
3. Turn governor cross shaft clockwise until lower end of shaft contacts cylinder. Make sure cross shaft remains in this position while installing camshaft.
4. Slide camshaft into bearing surface of crankcase, positioning timing mark of camshaft gear at 6 o'clock position. Make sure camshaft gear and crankshaft gear mesh, with both timing marks aligned.

Oil Pump Assembly

Oil pump is mounted inside closure plate. If service was required, and oil pump was removed, refer to assembly procedures under Oil Pump Assembly in Disassembly/ Inspection and Service.

Reassembly

Governor Gear Assembly (if equipped)

Governor gear assembly is located inside closure plate. If service was required, and governor was removed, refer to assembly procedures under Governor Gear Assembly in Disassembly/Inspection and Service.

Thrust Bearing, Washer and Shim

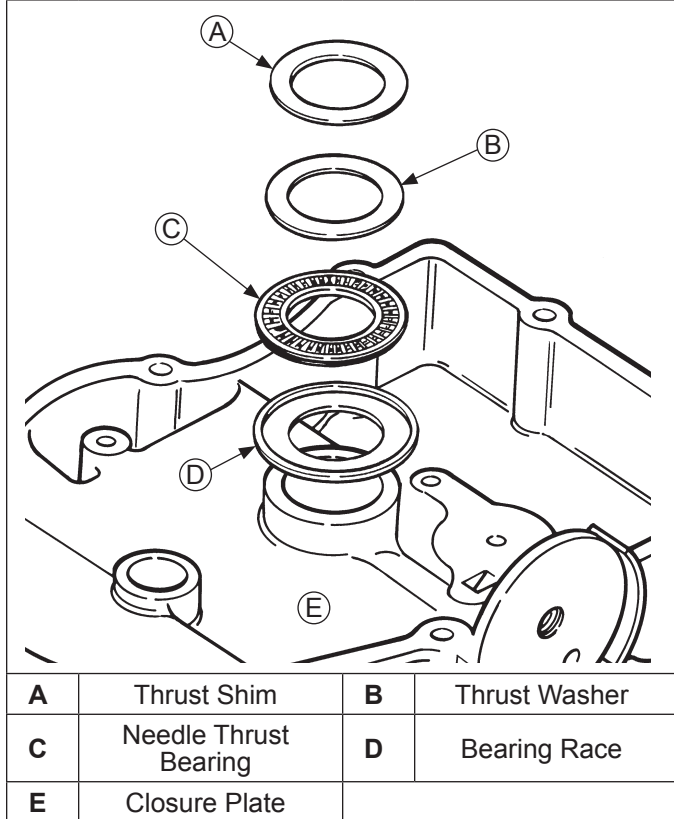

Some specifications use a needle type thrust bearing, thrust washer and shim spacer to control end play of crankshaft. If these items are noted during disassembly, make sure they are reinstalled in sequence shown. A different procedure will have to be followed to check and adjust crankshaft end play on these models.

Race for thrust bearing presses loosely into closure plate. If it is not already installed, push it into crankshaft bore inside closure plate. Pack thrust bearing with heavy grease and stick bearing into race. Wipe some grease on face of thrust washer and stick it onto thrust bearing. Wipe some grease on face of original shim spacer and stick it onto thrust washer.

Install closure plate onto crankcase without applying RTV sealant and secure it with only 2 or 3 fasteners at this time. Use a dial indicator to check crankshaft end play. End play should be 0.070/1.190 mm (0.0028/0.0468 in.). Shim spacers are available in 3 color coded thicknesses if adjustment is needed.

Clearance Specifications-Crankshaft End Play Shims

Green	0.8366-0.9127 mm (0.8750 mm/0.034 in. Nominal)
Yellow	1.0652-1.1414 mm (1.1033 mm/0.043 in. Nominal)
Red	1.2938-1.3700 mm (1.3319 mm/0.052 in. Nominal)

Remove closure plate. If end play requires adjustment, remove original spacer and install appropriate size shim spacer in its place. Then follow procedure under Install Closure Plate Assembly.

Install Closure Plate Oil Seal

Oil Seal Details

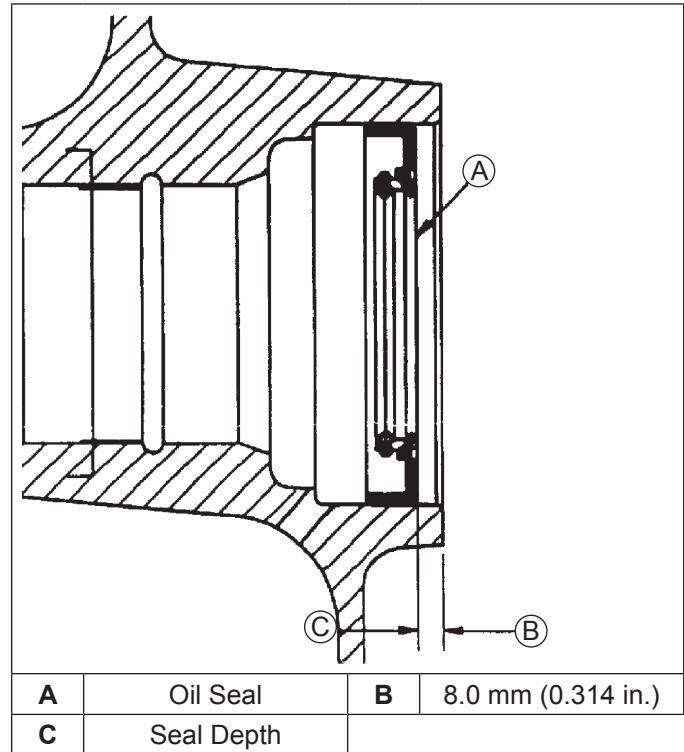

1. Check to make sure there are no nicks or burrs in crankshaft bore of closure plate.
2. Apply a light coat of P80 Emulsion Lubricant (refer to Tools and Aids) to outside diameter of oil seal.
3. Drive oil seal into closure plate using a seal driver. Make sure oil seal is installed straight and true in bore to depth shown.

Install Closure Plate Assembly

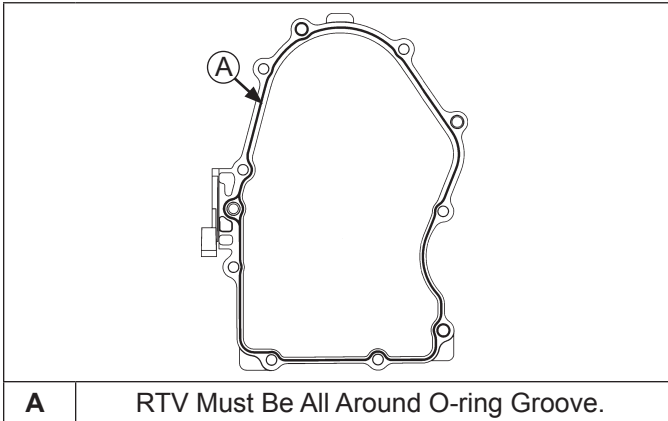

A RTV Must Be All Around O-ring Groove.

RTV sealant is used as a gasket between closure plate and crankcase. Refer to Tools and Aids for a listing of approved sealants. Always use fresh sealant. Using outdated sealant can result in leakage.

1. Be sure sealing surfaces have been cleaned and prepared as described at beginning of Disassembly/Inspection and Service. Install a new O-ring in closure plate.
2. Check to make sure there are no nicks or burrs on sealing surfaces of closure plate or crankcase.
3. Apply a 1.5 mm (1/16 in.) bead of sealant to sealing surface of closure plate. Verify O-ring is present. See sealant pattern.
4. Make sure end of governor cross shaft is lying against bottom of cylinder 1 inside crankcase.
5. Install closure plate to crankcase. Carefully seat camshaft and crankshaft into their mating bearings. Rotate crankshaft slightly to help engage oil pump and governor gear meshes.
6. Install screws securing closure plate to crankcase. Torque fasteners in sequence shown to 25.6 N·m (227 in. lb.). One mounting screws has a thread sealant patch. This screw is typically installed in #10 hole shown. Reapply pipe sealant with Teflon® (Loctite® 592™ PST® Thread Sealant or equivalent).

Closure Plate Fastener Torque Sequence

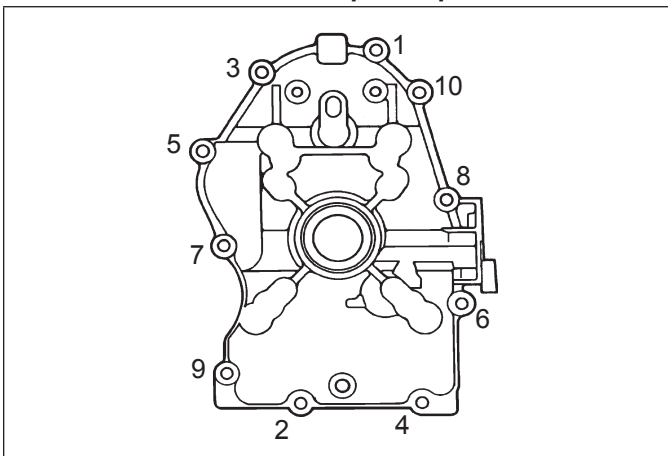

Install Stator and Backing Plate (ETB ECH EFI & ECH EFI)

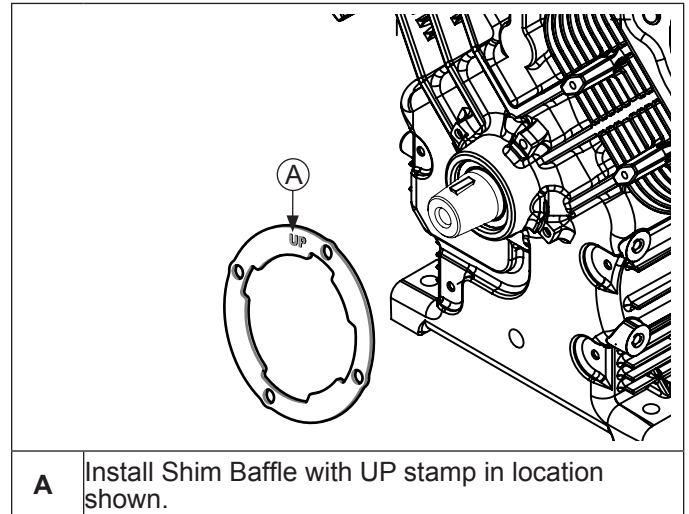

A Install Shim Baffle with UP stamp in location shown.

1. On ETB ECH EFI engines with high output charging system install shim baffle with UP stamp out and up.
2. Apply pipe sealant with Teflon® (Loctite® 592™ PST® Thread Sealant or equivalent) to stator mounting holes.
3. Position stator aligning mounting holes so leads are at bottom, towards crankcase.
4. Install and torque screws to 9.3 N·m (82 in. lb.).
5. Route stator leads in crankcase channel, then install backing plate. Secure using screws. Torque screws to 10.7 N·m (95 in. lb.) into new holes or 7.3 N·m (65 in. lb.) into used holes.

Reassembly

Install Flywheel

	⚠ CAUTION	Using improper procedures can lead to broken fragments. Broken fragments could be thrown from engine. Always observe and use precautions and procedures when installing flywheel.
	Damaging Crankshaft and Flywheel Can cause personal injury.	

Flywheel Components

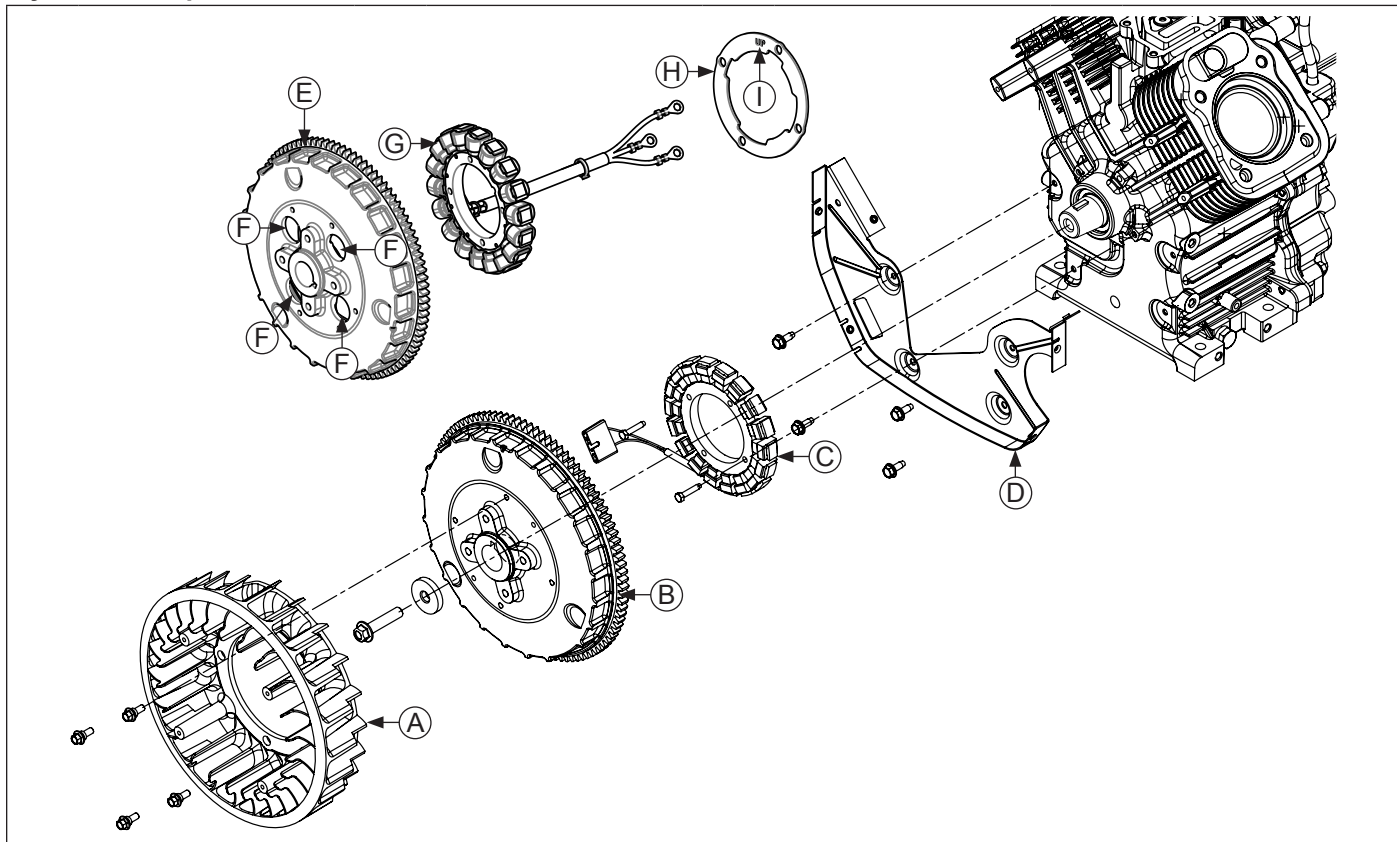

A	Flywheel Fan	B	Flywheel	C	Stator	D	Backing Plate
E	High Output Charging System Flywheel	F	4 Cooling Holes in High Output Charging System Flywheel	G	High Output Charging System Stator	H	High Output Charging System Shim Baffle
I	UP Stamp						

NOTE: Before installing flywheel make sure crankshaft taper and flywheel hub are clean, dry, and completely free of any lubricants. Presence of lubricants can cause flywheel to be over stressed and damaged when screw is torqued to specifications.

NOTE: Make sure flywheel key is installed properly in keyway. Flywheel can become cracked or damaged if key is not properly installed.

NOTE: High output charging system flywheel (identified by 4 large cooling holes) has very strong magnets. Magnet assembly guard on interior of this flywheel has a thin, sharp edge. Wear protective gloves when handling this flywheel.

1. Install woodruff key into keyway of crankshaft. Make sure key is properly seated and parallel with shaft taper.
2. Install flywheel onto crankshaft being careful not to shift woodruff key. ETB ECH EFI engines with high output charging system have a flywheel with very strong magnets. Wear protective gloves and use a flywheel puller to help line up flywheel and crankshaft before magnets pull flywheel into place.
3. Install screw and washer.

4. Use a flywheel strap wrench or holding tool to hold flywheel. Torque screw securing flywheel to crankshaft to 71.6 N·m (52.8 ft. lb.).

Install Fan

NOTE: Position locating tabs on back of fan in locating holes of flywheel.

1. Install fan onto flywheel using screws (engines with plastic grass screen). Engines with a metal grass screen will leave fan loosely assembled.
2. Torque screws to 9.9 N·m (88 in. lb.).

Install Hydraulic Lifters

NOTE: Hydraulic lifters should always be installed in same position as before disassembly. Exhaust lifters are located on output shaft side of engine while intake lifters are located on fan side of engine. Cylinder numbers are embossed on top of crankcase and each cylinder head.

1. See Servicing Hydraulic Lifters in Disassembly/ Inspection and Service.
2. Apply camshaft lubricant to bottom surface of each lifter. Lubricate hydraulic lifters and lifter bores in crankcase with engine oil.
3. Note mark or tag identifying hydraulic lifters as either intake or exhaust and cylinder 1 or cylinder 2. Install hydraulic lifters into their appropriate location in crankcase. Do not use a magnet.
4. If breather reeds and stops were removed from crankcase, reinstall them at this time and secure with screw. Torque screw to 4.0 N·m (35 in. lb.).

Cylinder Head Components

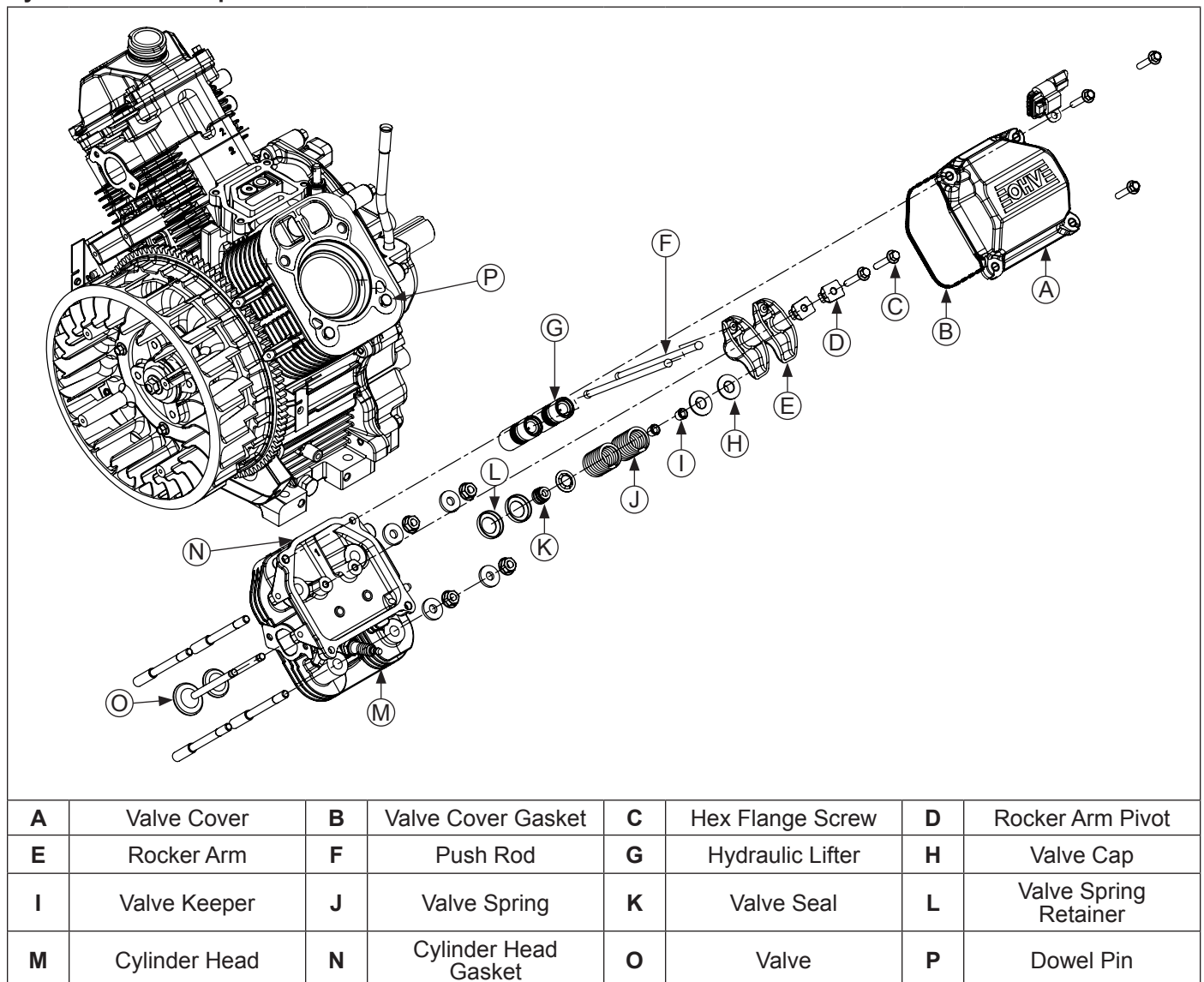

Reassembly

Valve Stem Seals

These engines use valve stem seals on intake valves and on exhaust valves. Always use a new seal whenever valve is removed or if seal is deteriorated or damaged in any way. Never reuse an old seal.

Assemble Cylinder Heads

Prior to installation, lubricate all components with engine oil, paying particular attention to lip of valve stem seal, valve stems, and valve guides. Install following items in order listed below using a valve spring compressor.

- Intake and exhaust valves.
- Valve spring retainers.
- Valve springs.
- Valve spring caps.
- Valve spring keepers.

Install Cylinder Heads

Torque Sequence

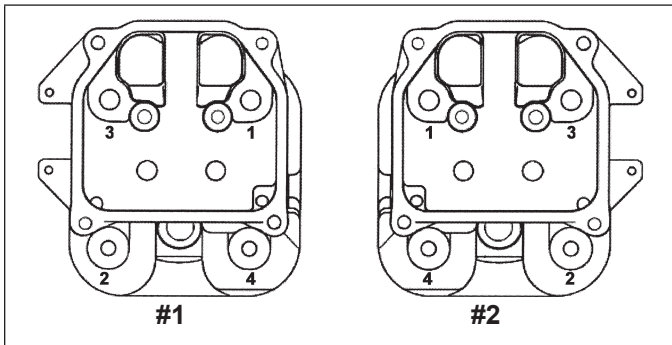

NOTE: Cylinder heads must be attached with original type of mounting hardware, using either screws, or mounting studs with nuts and washers. Do not intermix components.

NOTE: Match numbers embossed on cylinder heads and crankcase.

1. Check to make sure there are no nicks or burrs on sealing surfaces of cylinder head or crankcase.

Heads secured with mounting studs, nuts, and washers:

2. If all studs were left intact, go to Step 6. If any studs were disturbed or removed, install new studs as described in Step 3. Do not use/reinstall any loosened or removed studs.
3. Install new mounting stud(s) into crankcase.
 - a. Thread and lock 2 mounting nuts together on smaller diameter threads.
 - b. Thread opposite end of stud with preapplied locking compound into crankcase until specified height from crankcase surface is achieved. When threading in studs, use a steady tightening motion without interruption until proper height is obtained. Otherwise, frictional heat from engaging threads may cause locking compound to set up prematurely.

Studs closest to lifters must have an exposed height of 75 mm (2 15/16 in.).

Studs furthest from lifters must have an exposed height of 69 mm (2 3/4 in.).

- c. Remove nuts and repeat procedure as required.
4. Check dowel pins are in place and install a new cylinder head gasket (part number facing up).
5. Install cylinder head. Match numbers on cylinder heads and crankcase. Make sure head is flat on gasket and dowel pins.
6. Lightly lubricate exposed (upper) threads of studs with engine oil. Install a flat washer and hex nut onto each mounting stud. Torque hex nuts in 2 stages; first to 16.9 N·m (150 in. lb.), finally to 33.9 N·m (300 in. lb.). Follow torque sequence.

Heads secured with screws:

2. Install a new cylinder head gasket, (part number facing up).
3. Install cylinder head and start screws.
4. Torque screws in 2 stages; first to 22.6 N·m (200 in. lb.), finally to 41.8 N·m (370 in. lb.). Follow torque sequence.

Install Push Rods and Rocker Arms

NOTE: Push rods should always be installed in same position as before disassembly.

NOTE: Two different screws have been used to secure rocker arms/pivots. Black screws are used with heads that have a rocker pivot hole depth of approximately 21 mm (0.83 in.). Silver screws are used with heads that have a rocker pivot hole depth of approximately 35 mm (1.38 in.).

1. Note mark or tag identifying push rod as either intake or exhaust and cylinder #1 or #2. Dip ends of push rods in engine oil and install, making sure each push rod ball seats in its hydraulic lifter socket.
2. Apply grease to contact surfaces of rocker arms and rocker arm pivots. Install rocker arms and rocker arm pivots on 1 cylinder head, and start screws.
3. Torque black screws to 18.1 N·m (160 in. lb.). Torque silver screws to 11.9 N·m (105 in. lb.). Repeat for other rocker arm.
4. Use a spanner wrench or rocker arm lifting tool (see Tools and Aids) to lift rocker arms and position push rods underneath.
5. Repeat above steps for remaining cylinder. Do not interchange parts from cylinder heads.
6. Rotate crankshaft to check for free operation of valve train. Check clearance between valve spring coils at full lift. Minimum allowable clearance is 0.25 mm (0.010 in.).

Check Assembly

Important: Rotate crankshaft a minimum of 2 revolutions to check long block assembly and overall proper operation.

Install Spark Plugs

1. Check gap using wire feeler gauge. Adjust gap to 0.76 mm (0.030 in.).
2. Install plug into cylinder head.
3. Torque plug to 27 N·m (20 ft. lb.).

Intake Manifold Components (ETB ECH EFI & ECH EFI)

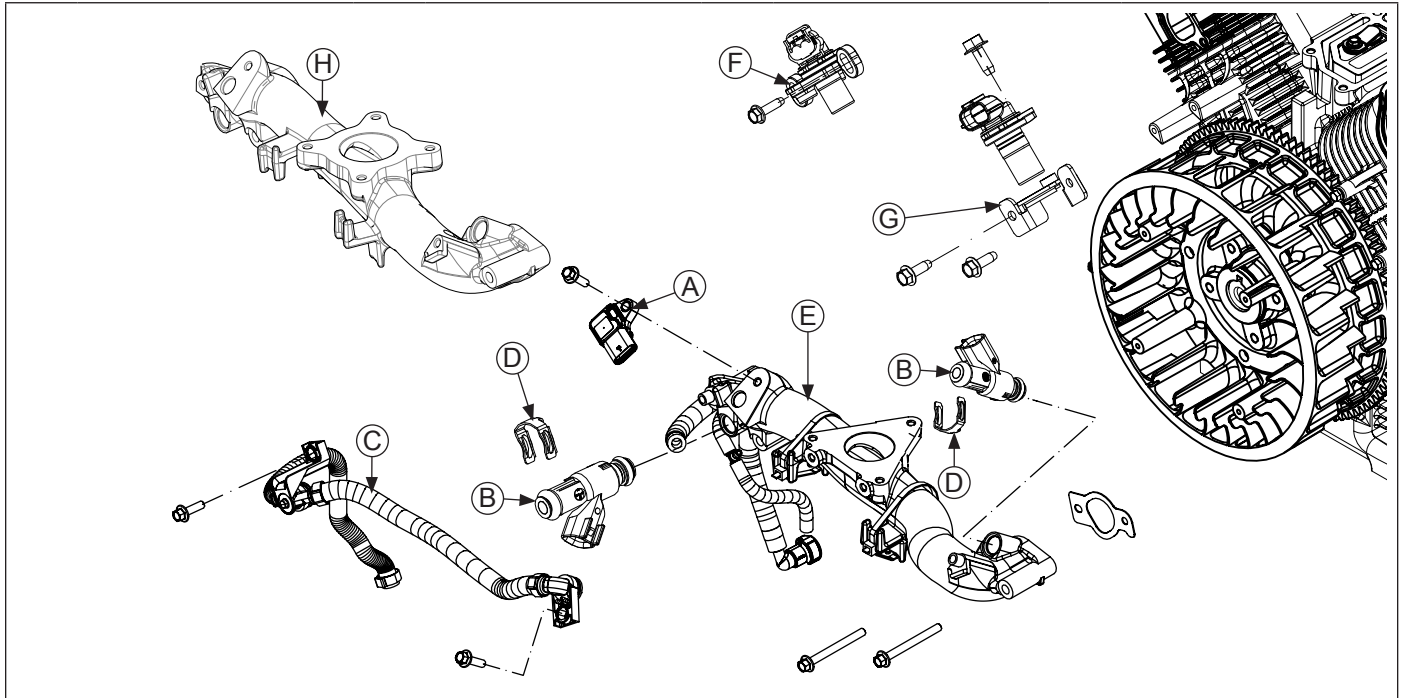

A	MAP or TMAP Sensor	B	Fuel Injector	C	Fuel Rail	D	Metal Retaining Clip
E	Intake Manifold	F	Crankshaft Position Sensor (Earlier Design Bracket)	G	Crankshaft Position Sensor (Later Design Bracket)	H	ETB Intake Manifold

Install Intake Manifold

Torque Sequence

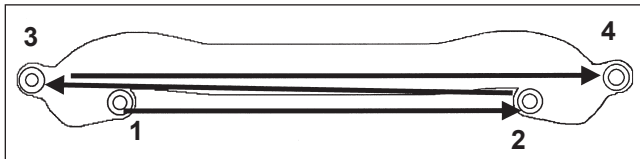

1. Install intake manifold and new gaskets, with wiring harness attached, to cylinder heads. Slide any wiring harness clips onto appropriate bolts before installing. Make sure gaskets are in proper orientation. Torque screws in 2 stages, first to 7.8 N·m (69 in. lb.), then to 10.5 N·m (93 in. lb.), using sequence shown.
2. Install ground terminal to crankcase post with a silver screw. Torque to 4.0 N·m (35 in. lb.) into used holes or 6.2 N·m (55 in. lb.) into new holes.
3. Install wire harness clip to other crankcase post and position bracket to direct harness for proper blower housing installation. Torque screw to 4.0 N·m (35 in. lb.) into used holes or 6.2 N·m (55 in. lb.) into new holes.
4. Place wire harness conduit in clip and snap clip together.

Install Fuel Injectors

NOTE: Ensure all parts are clean, undamaged and free of debris and make sure electrical connectors have seal in place.

1. Lightly lubricate fuel injector O-rings with clean engine oil.
2. Push retaining clip onto fuel injector, aligning clip.
3. Press fuel injector into fuel injector cap until retaining clip snaps into place.
4. Press fuel injector into bore in intake manifold and rotate to original position.
5. Install fuel injector cap screw into intake manifold and torque to 7.3 N·m (65 in. lb.).
6. Push electrical connector on fuel injector making sure a good connection is made.
7. Repeat steps 1 through 6 for other fuel injector.

Reassembly

Install Manifold Absolute Pressure (MAP) Sensor or Temperature/Manifold Absolute Pressure (TMAP) Sensor

NOTE: Ensure all parts are clean, undamaged and free of debris and make sure electrical connector has seal in place.

1. Lightly oil MAP or TMAP sensor O-ring and push sensor into bore in intake manifold.
2. Torque screw to 7.3 N·m (65 in. lb.).
3. Push electrical connector on MAP or TMAP sensor making sure a good connection is made.

Install Crankshaft Position Sensor

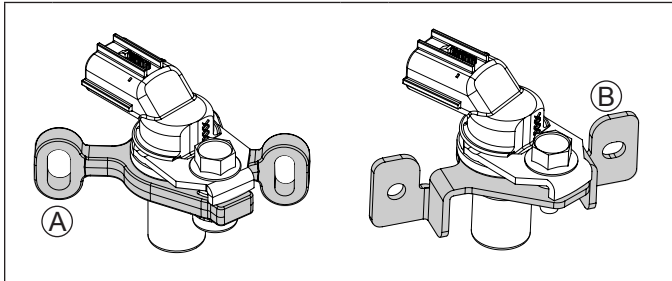

A	Earlier Design Bracket	B	Later Design Bracket
----------	------------------------	----------	----------------------

NOTE: Ensure all parts are clean, undamaged and free of debris and make sure electrical connectors have seal in place.

NOTE: On engines with earlier design bracket, an air gap must be set when installing. Later design brackets require no adjustment.

1. Install crankshaft position sensor and bracket assembly to crankcase posts.
2. On engines with earlier design bracket, snug screws and check air gap of sensor with a feeler gauge. It must be 0.20-0.70 mm (0.008-0.027 in.). Torque bracket screws to crankcase to 8.3 N·m (73 in. lb.).
On engines with later design bracket, secure bracket assembly to crankcase posts. Torque bracket screws to crankcase to 7.3 N·m (65 in. lb.).
3. Push electrical connector on crankshaft position sensor making sure a good connection is made.

Install Valve Covers

Torque Sequence

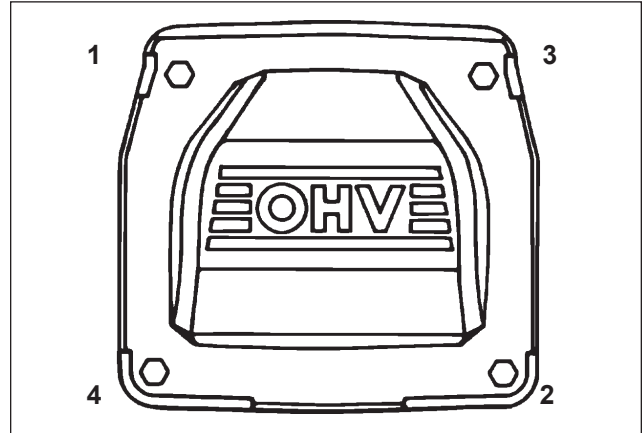

1. Make sure sealing surfaces are clean.
2. Make sure there are no nicks or burrs on sealing surfaces.
3. Install a new O-ring in groove of each cover.
4. Position covers on cylinder heads including any clips, lifting straps, or brackets that were present prior to disassembly. Install screws in each cover and finger tighten.
5. Torque valve cover fasteners to 9.0 N·m (80 in. lb.) using sequence shown.

External Engine Components

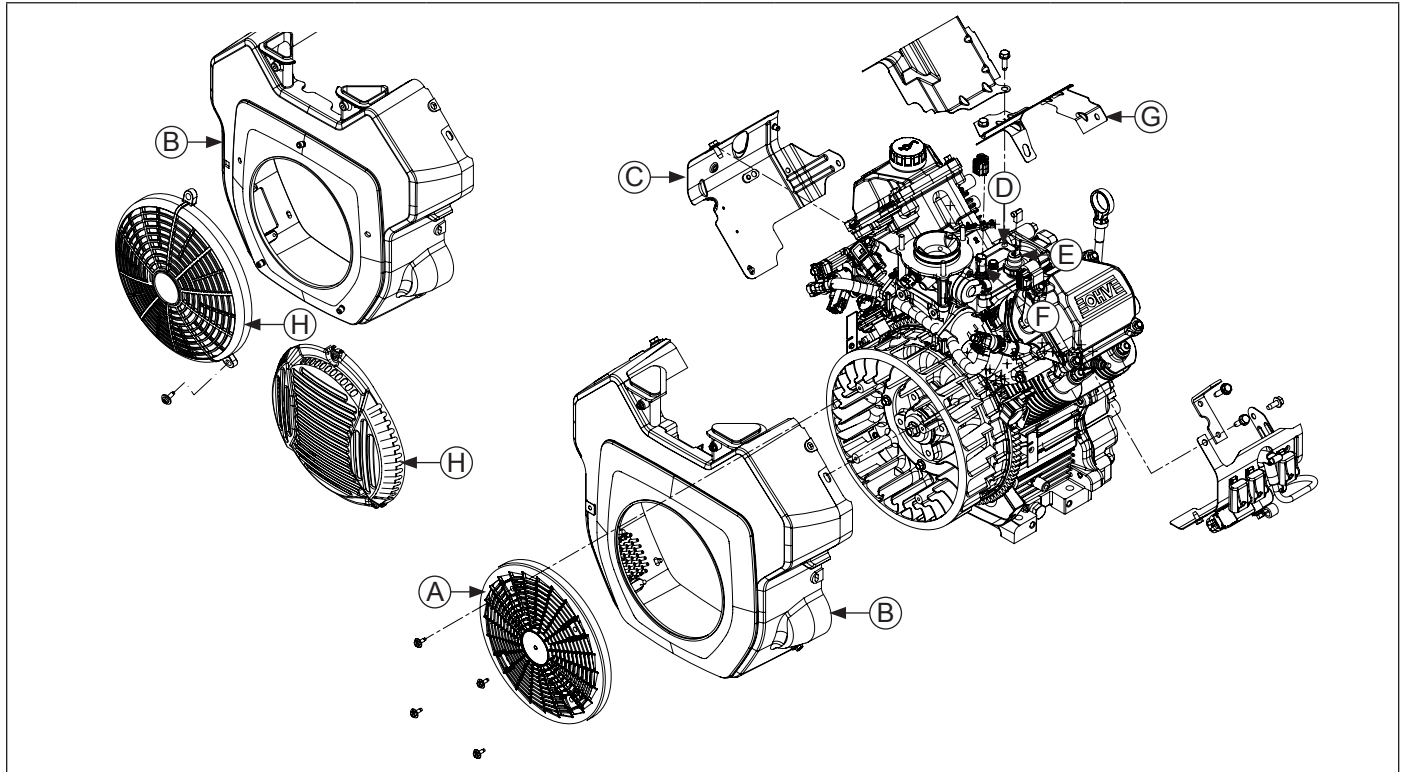

A	Debris Screen	B	Blower Housing	C	Outer Baffle	D	Breather Cover
E	Oil Sentry™	F	Oil Temperature Sensor	G	Inner Baffle	H	Debris Screen Guard

Install Breather Cover and Inner Baffles

Torque Sequence

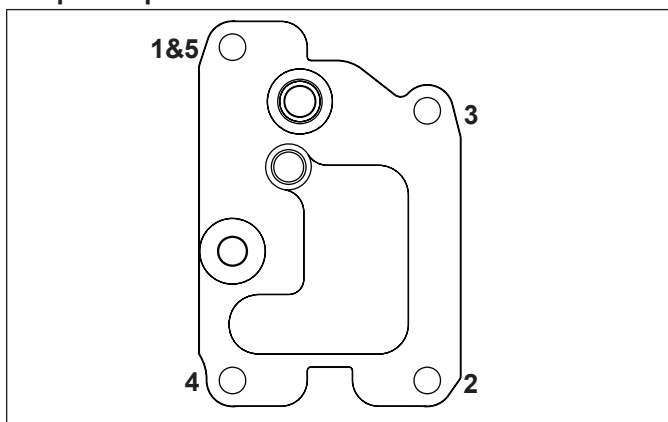

1. Be sure sealing surfaces of crankcase and breather cover are clean of old gasket material. Do not scrape surfaces as this could result in leakage. Use a new gasket when installing breather cover.
2. Check to make sure there are no nicks or burrs on sealing surfaces.
3. Position breather gasket and cover on crankcase. Install screws in locations 3 and 4. Finger tighten at this time.

4. Install inner baffles using remaining screws and finger tighten. Do not torque screws at this time; they will be tightened after blower housing.
5. On ETB ECH EFI engines, secure wire clip into #1 inner baffle.

Install Engine Temperature Sensor (ETB ECH EFI & ECH EFI) or Engine Temperature Sensor Lead (ETB ECH EFI)

Engines will have either a sensor mounted in breather cover or a sensor lead that secures on #2 cylinder valley baffle closest to exhaust port. Follow reassembly procedure for design on engine being serviced.

Engine Temperature Sensor Lead

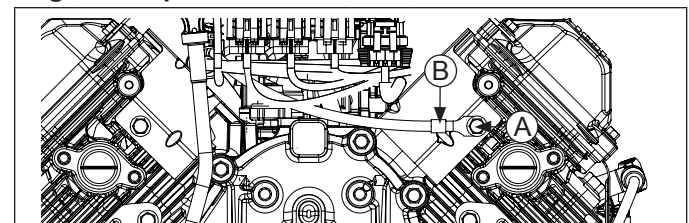

A	Baffle Screw	B	Engine Temperature Sensor Lead
----------	--------------	----------	--------------------------------

1. Position engine temperature sensor lead on baffle and install screw.
2. Reconnect engine temperature sensor lead connector to wiring harness.

Reassembly

Engine Temperature Sensor (Breather Cover)

NOTE: Ensure part is clean, undamaged and free of debris and make sure electrical connector has seal in place.

1. Lightly lubricate engine temperature sensor O-ring and install engine temperature sensor into breather cover.
2. Torque sensor to 7.3 N·m (65 in. lb.).
3. Push electrical connector on engine temperature sensor making sure a good connection is made.

Install Oil Sentry™ (if equipped)

1. Apply pipe sealant with Teflon® (Loctite® 592™ PST® Thread Sealant or equivalent) to threads of Oil Sentry™ switch and install it into breather cover. Torque to 4.5 N·m (40 in. lb.).
2. Connect wire lead (green) to Oil Sentry™ terminal.

Install Blower Housing and Outer Baffles

NOTE: Do not completely tighten screws until all items are installed to allow shifting for hole alignment.

1. Slide blower housing into position over front edge of inner baffles. Start a few screws to hold it in place.
2. Position outer baffles and secure using M6 screws. Install M6 screws (20 mm long) into intake port side of cylinder heads, including any lifting strap. Install 2 M6 screws (16 mm long) into exhaust port side of cylinder head. Install 2 short M5 screws (10 mm long) in upper mounting holes of outer baffles (into backing plate). Be sure any leads are routed out through proper offsets or notches, so they will not be pinched between blower housing and baffles.

On ETB ECH EFI engines, push evap line clip into #2 side outer baffle to secure and reinstall clip securing wiring harness to backing plate.

3. If removed, install ignition coils onto baffles. Ensure that any clips noted in disassembly are reinstalled. Torque screws to 10.2 N·m (90 in. lb.).

On ETB ECH EFI engines with high output charging system, secure wiring harness in clip on #1 side coil.

4. Insert and tighten all remaining blower housing and baffle screws with exception of rectifier-regulator grounding bracket/lead screw (standard charging system).

Torque all blower housing and baffle M6 screws assembled into aluminum to 10.7 N·m (95 in. lb.) for a new hole, or 7.3 N·m (65 in. lb.) for a used hole.

Torque all blower housing and baffle M5 screws assembled into sheet metal (backing plate) to 2.8 N·m (25 in. lb.) for new holes, or 2.3 N·m (20 in. lb.) for used holes.

5. ETB ECH EFI engines with standard charging system, install LPAC support bracket with fuse holders. Torque screws to 10.7 N·m (95 in. lb.) for a new hole, or 7.3 N·m (65 in. lb.) for a used hole.
6. Torque breather cover screws to 11.3 N·m (100 in. lb.) into new holes or 7.3 N·m (65 in. lb.) into used holes in sequence shown. Note first screw is torqued a second time.

7. ETB ECH EFI engines with standard charging system, install fuses and diagnostic connector into bracket.

Install Rectifier-Regulator (Standard Charging System)

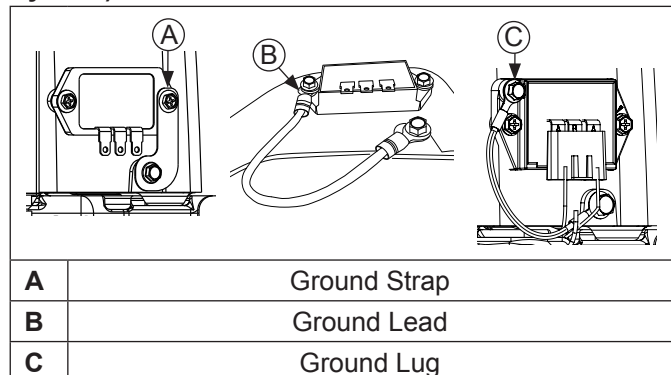

NOTE: Rectifier-regulator middle terminal (B+) is offset (not equally spaced) from outer terminals (AC). Verify rectifier-regulator plug is assembled to match terminal offset of rectifier-regulator.

1. Install rectifier-regulator in blower housing if removed previously. Reinstall any washers and hose clamps.
 - a. If engine has ground strap, secure it against outer side of rectifier-regulator with a silver or green plated screw.
 - b. If engine has ground lead that secures in same hole as rectifier-regulator fastener, secure one end to rectifier-regulator and other end to backing plate.
 - c. If engine has ground lead that secures in separate ground lug fastener hole in rectifier-regulator, secure one end to ground lug and other end to backing plate.
2. Torque black rectifier-regulator screws to 1.4 N·m (12.6 in. lb.).
 - a. Torque silver or green ground strap screw to 2.8 N·m (25 in. lb.) into new holes or 2.3 N·m (20 in. lb.) into used holes.
 - b. Ground lead that secures in same hole as rectifier-regulator fastener, torque screw securing to backing plate to 2.8 N·m (25 in. lb.) into new holes or 2.3 N·m (20 in. lb.) into used holes.
 - c. Ground lead that secures in ground lug hole of rectifier-regulator and to backing plate, torque screws to 5.6 N·m (50 in. lb.) into new holes or 4.0 N·m (35 in. lb.) into used holes.
3. Connect plug to rectifier-regulator. If purple wire was removed, verify locking tang is raised on terminal and push wire terminal into plug prior to connecting to rectifier-regulator.

Install Metal Debris Screen (if equipped)

Spring Washer Details

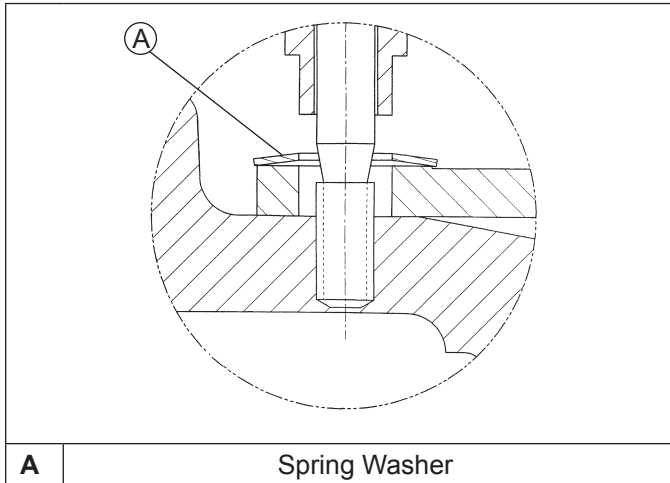

A	Spring Washer
----------	---------------

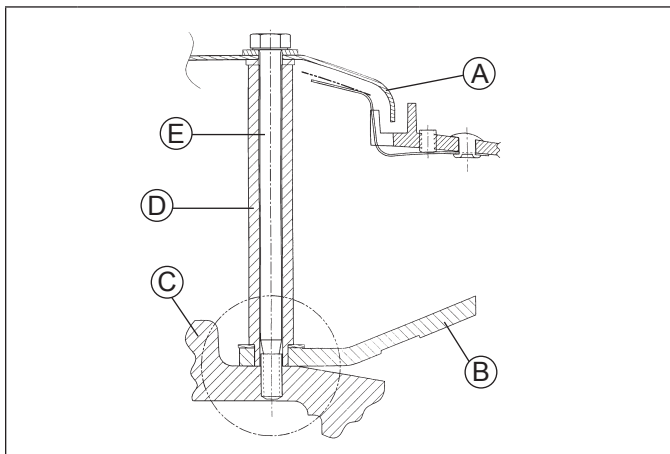

A	Metal Debris Screen	B	Fan
C	Flywheel	D	Spacer
E	Hex Bolt		

1. Verify locating tabs on back of fan are inserted into locating holes on flywheel.
2. To assist assembly, find 4 intake manifold studs with M6 thread at least 100 mm in length to be used as guide pins. Insert intake manifold studs through cooling fan mounting holes and thread them 4 or 5 turns into flywheel.
3. Install a spring washer on each stud with concave side down toward cooling fan.
4. Install a spacer on each stud with stepped end down. Smaller diameter should extend through spring washer and fan, so tip is resting on flywheel, and shoulder is resting on spring washer.
5. Install support ring on studs, so it is resting on spacers. Then install metal screen on top of support ring.
6. Install plain washers on each hex cap screw. Apply Loctite® 242® to hex cap screw threads.
7. Carefully remove 2 studs and replace with 2 screws. Torque screws to 9.9 N·m (88 in. lb.). Repeat procedure for other 2 studs and screws.

Install Plastic Debris Screen (if equipped)

Place plastic grass screen on fan and secure with hex screws. Torque screws to 4.0 N·m (35 in. lb.).

Install Debris Screen Guard (if equipped)

Position guard on blower housing and secure with screws (and spacers).

Install Electric Starter Motor and ECU Bracket (ETB ECH EFI & ECH EFI)

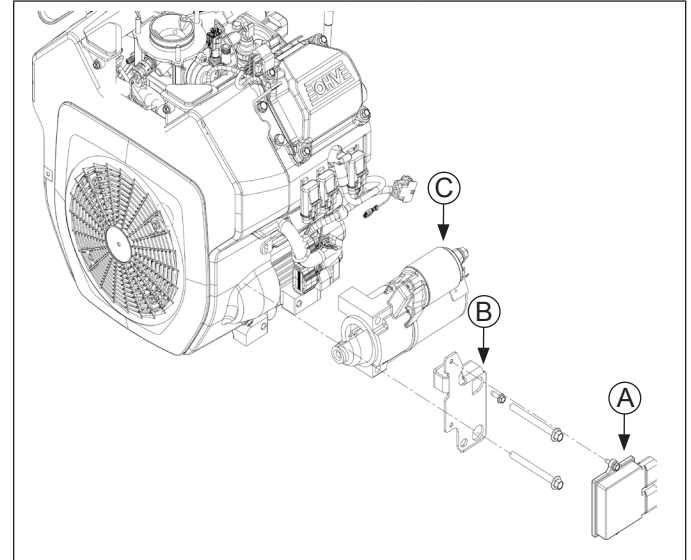

A	Electronic Control Unit (ECU)	B	ECU Bracket
C	Starter		

1. Plug connector into ignition coil.
2. Install electric starter motor and ECU bracket using screws. Position ECU bracket as shown.

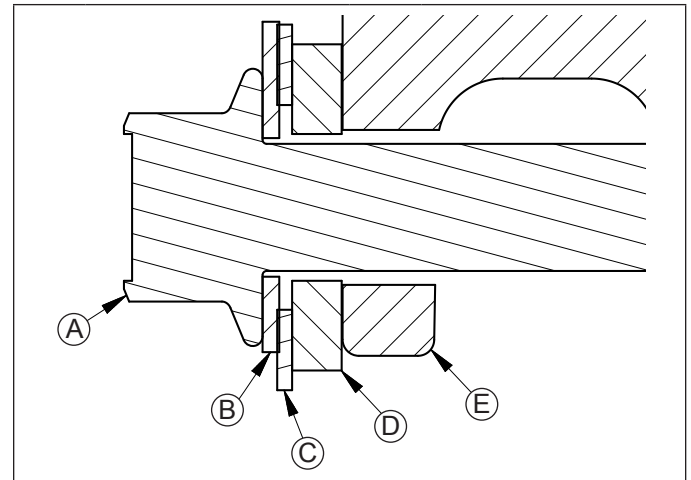

A	Starter Screw	B	Ground Lead
C	Internal/External Tooth Lock Washer	D	ECU Bracket
E	Starter		

Reassembly

ETB ECH EFI engines with high output charging system have black ground lead ring terminal and lock washer on lower starter screw.

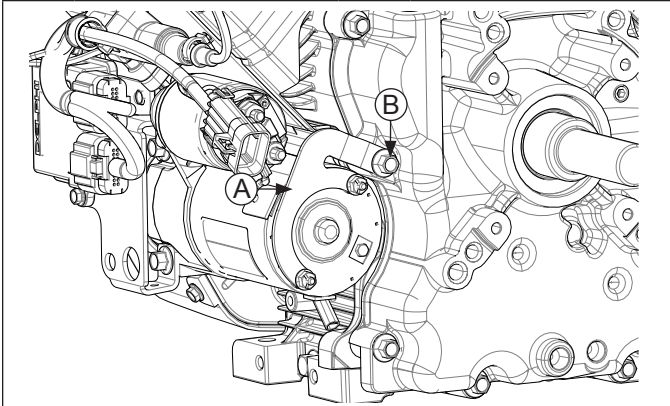

A	Rear Starter Bracket	B	Closure Plate Screw
----------	----------------------	----------	---------------------

- ETB ECH EFI engines equipped with rear starter bracket, secure bracket to closure plate. Torque screw to 25.6 N·m (227 in. lb.).
- Torque starter mounting screws to 16.0 N·m (142 in. lb.).
- Install screw to secure bracket to blower housing.
- Connect leads to solenoid.

Install Electronic Control Unit (ECU) (ETB ECH EFI & ECH EFI)

NOTE: ECU pins should be coated with a thin layer of electrical grease to prevent fretting and corrosion and may need to be reapplied if ECU is being reused.

- Install ECU to ECU bracket using screws. Torque M5 screws to 6.2 N·m (55 in. lb.) into new holes or 4.0 N·m (35 in. lb.) into used holes.
- Connect Black and Grey electrical connectors. Connectors and ECU are keyed in such a way so they cannot be installed incorrectly.

Install Throttle Body

Throttle Body Components (ECH EFI)

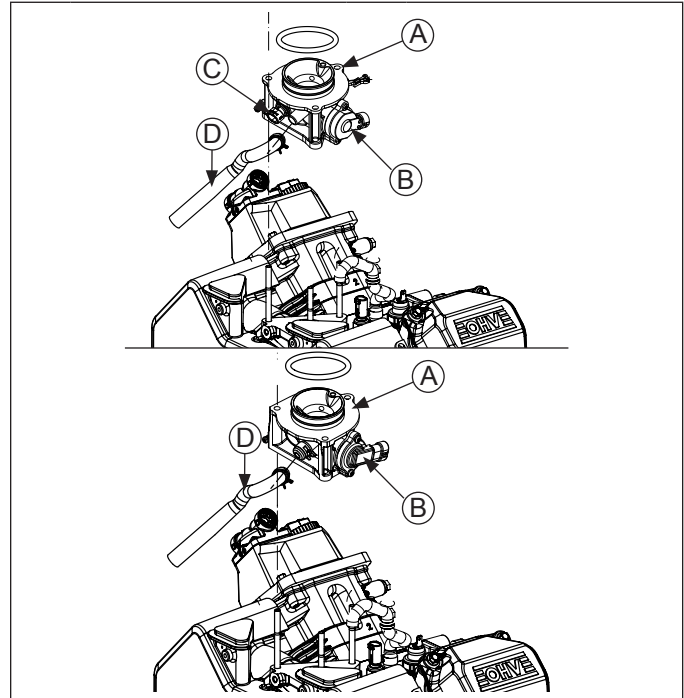

A	Throttle Body	B	Throttle Position Sensor (TPS)
C	Intake Air Temperature (IAT) Sensor	D	Breather Tube

NOTE: Ensure all parts are clean, undamaged and free of debris and make sure electrical connector has seal in place.

NOTE: Earlier engines have separate IAT and MAP sensors.

- Install a new throttle body O-ring prior to installation. Make sure all holes align and are open.
- Install throttle body, throttle position sensor, intake air temperature (IAT) sensor (earlier engines only), throttle linkage, spring and bushing, as an assembly.
- Install air cleaner bracket (models with heavy-duty air cleaner only) to valve covers. Torque screws to 9.9 N·m (88 in. lb.).
- On earlier engines with separate intake air temperature (IAT) and MAP sensor, push electrical connector onto IAT sensor making sure a good connection is made by listening for a click.
- Connect breather hose to throttle body using a pliers to compress spring clamp. Route hose around throttle body and connect to breather cover using a spring clamp.
- Connect 5/32" I. D. vent hose from fuel pump module to throttle body.
- Push electrical connector onto throttle position sensor making sure a good connection is made.

Electronic Throttle Body Components (ETB ECH EFI)

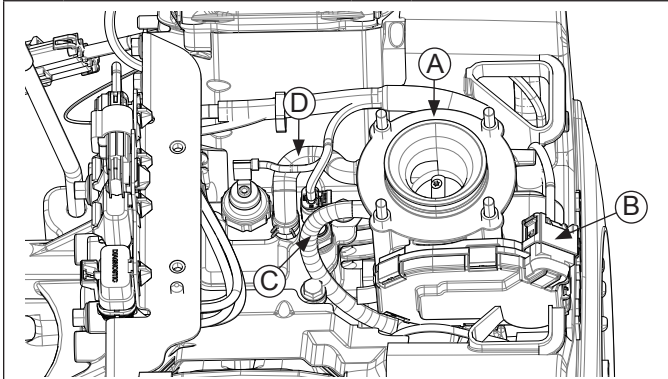

A	Electronic Throttle Body (ETB)	B	TPS/ETB Connector
C	Vent Hose	D	Breather Hose

NOTE: Ensure all parts are clean, undamaged and free of debris and make sure electrical connector has seal in place.

1. Install a new throttle body O-ring into bottom of ETB. Position ETB on intake manifold.

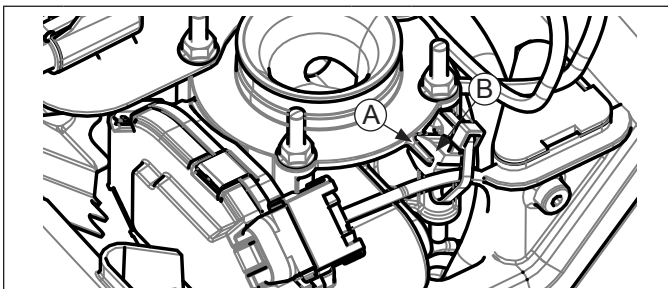

A	ETB Rib	B	Wire Tie Retention Teeth
----------	---------	----------	--------------------------

2. Connect TPS/ETB connector. Carefully bend up retention teeth in edge fixed wire tie and secure to ETB rib.
3. Connect vent hose to ETB
4. Connect breather hose to breather cover and position clamp to secure.

Connect Fuses and Install ETB LPAC Support Bracket

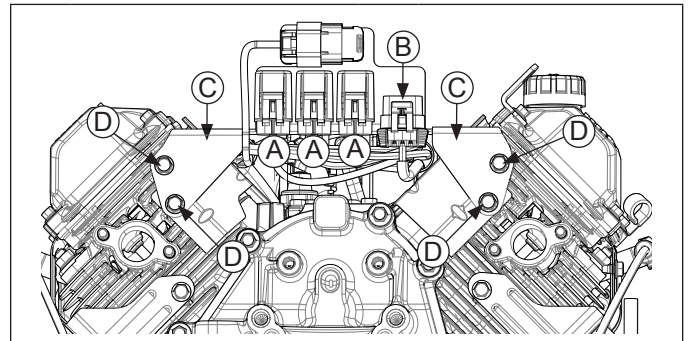

A	Fuses	B	Diagnostic Connector
C	LPAC Support Bracket	D	Screw

NOTE: On oil filter side of certain engines, screw closest to exhaust port may also secure engine temperature sensor lead between bracket and baffle.

1. Install screws securing bracket with fuse and diagnostic caps to engine.
2. Install fuse holders into connectors on LPAC support bracket. Install diagnostic plug into cap.

Reassembly

Install High Output Charging System Rectifier-Regulator and Electronic Throttle Body Components (ETB ECH EFI)

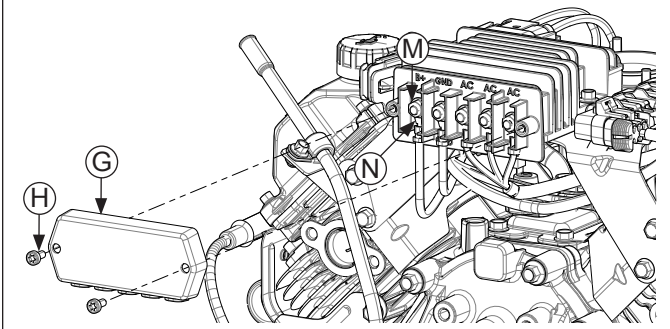
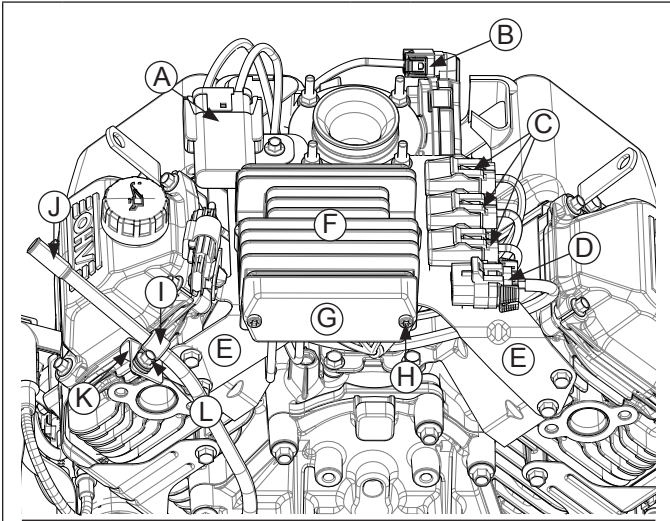

A	High Output Charging Fuse	B	TPS/ETB Connector
C	Fuses	D	Diagnostic Connector
E	Rectifier-Regulator Bracket	F	Rectifier-Regulator
G	Terminal Block Cover	H	Torx Screw
I	Clamp	J	Dipstick Tube
K	Support Bracket	L	Screw
M	Nut	N	Ring Terminal

NOTE: On oil filter side of certain engines, screw closest to exhaust port may also secure engine temperature sensor lead between bracket and baffle.

1. Install a new throttle body O-ring into bottom of ETB. Position ETB with O-ring on intake manifold.

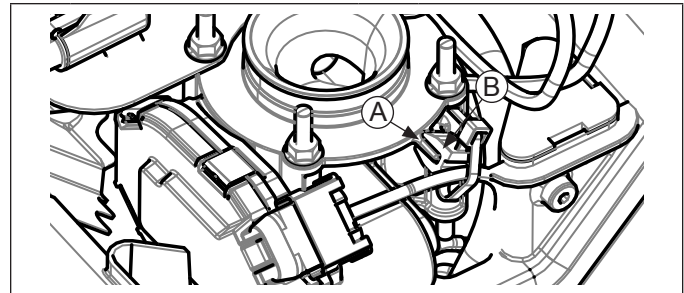

A	ETB Rib	B	Wire Tie Retention Teeth
----------	---------	----------	--------------------------

2. Connect TPS/ETB connector. Carefully bend up retention teeth in edge fixed wire tie and secure to ETB rib.
3. Connect vent hose to ETB.
4. Connect breather hose to breather cover and position clamp to secure.
5. If removed, secure high output charging fuse cover/bracket to regulator bracket and torque screw to 8.3 N·m (73 in. lb.).
6. Position rectifier-regulator on bracket and secure with screws. Torque screws to 8.3 N·m (73 in. lb.).
7. Position bracket with rectifier-regulator on engine and secure with screws to cylinder heads. Do not tighten.
Some engines also have a dipstick tube support bracket secured with this bracket on #1 side. Install screw and clamp securing tube to support bracket.
8. Install nuts to secure rectifier-regulator bracket and throttle body. Torque nuts to 8.3 N·m (73 in. lb.). Then torque screws to 12.5 N·m (110 in. lb.).
9. Reinstall lead terminals to rectifier-regulator and secure with nuts. Torque nuts to 4.0 N·m (35 in. lb.). Install terminal block cover and secure with Torx screws. Torque screws to 2.8 N·m (25 in. lb.).
10. Route wires under rectifier-regulator bracket and install fuses and diagnostic connector into caps.



⚠ WARNING

Explosive Fuel can cause fires and severe burns.

Do not fill fuel tank while engine is hot or running.

Gasoline is extremely flammable and its vapors can explode if ignited. Store gasoline only in approved containers, in well ventilated, unoccupied buildings, away from sparks or flames. Spilled fuel could ignite if it comes in contact with hot parts or sparks from ignition. Never use gasoline as a cleaning agent.

Fuel Pump (ETB ECH EFI & ECH EFI)

Install Lift Fuel Pump and Fuel Pump Module

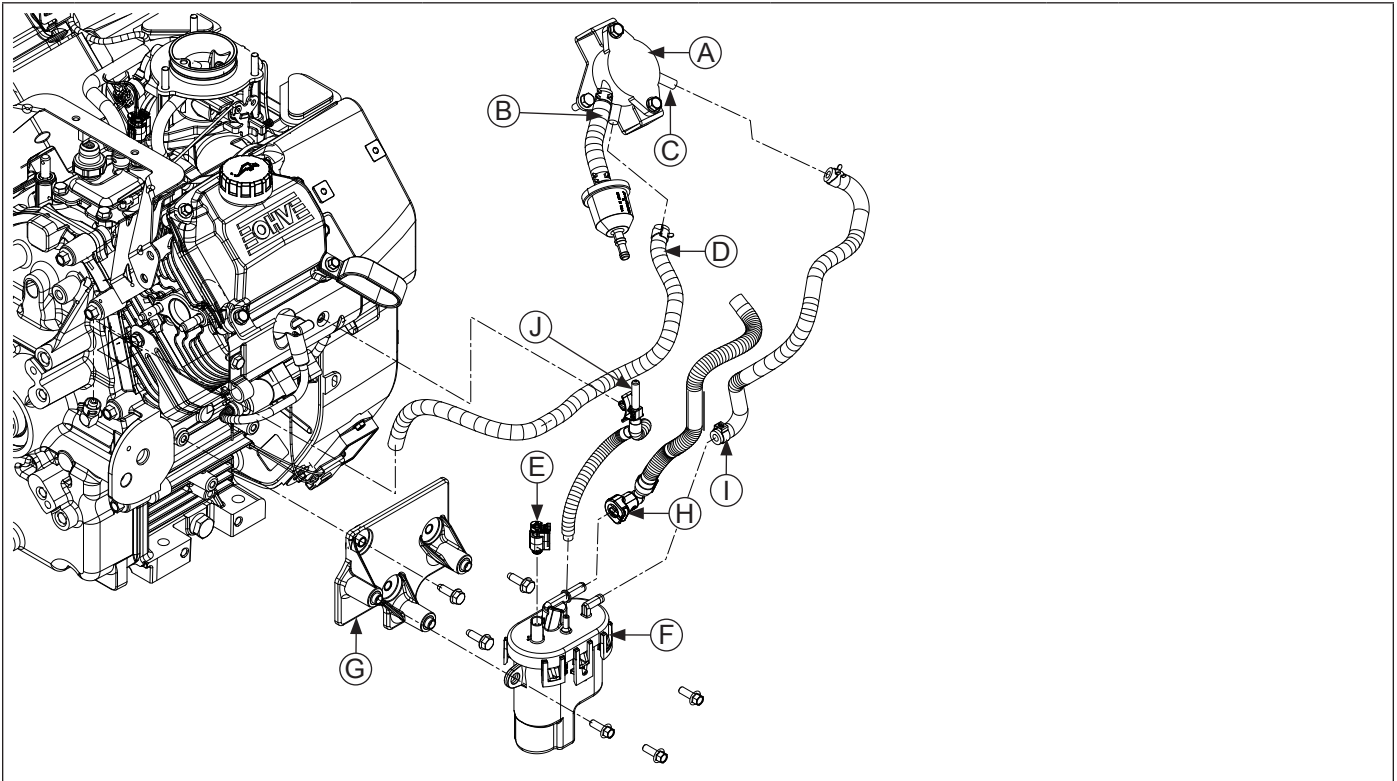

A	Pulse Pump	B	Inlet Hose	C	Outlet to Fuel Pump Module	D	Pulse Hose
E	Electrical Connector	F	Fuel Pump Module	G	Fuel Pump Module Baffle	H	High Pressure Fuel Line Connector
I	Oetiker Clamp	J	Purge Port/Vent Fitting				

NOTE: Some applications may have 2 in-line fuel filters. In those applications, connect in-line 51-75 micron mesh fuel filter and hose to inlet barb of lift fuel pump and secure with a spring clamp. In-line 10 micron EFI paper fuel filter and hose must be connected to outlet barb of lift fuel pump and secured with a spring clamp.

NOTE: Ensure all parts are clean, undamaged and free of debris and make sure electrical connector has seal in place.

NOTE: Fuel pump module pins should be coated with a thin layer of electric grease to prevent fretting and corrosion and may need to be reapplied if fuel pump module is being reused.

Reassembly

ETB ECH EFI

1. Connect electrical connector to ignition coil.
2. Install fuel pump module baffle to crankcase using screws. Torque screws to 11.9 N·m (105 in. lb.).
3. Route fuel line inlet hose (if equipped) through clamp and push high pressure fuel line connector onto fuel pump module fitting.
4. If Oetiker clamp was cut to remove inlet fuel line, slide a new Oetiker clamp onto fuel line and connect fuel line. Only use an Oetiker clamp pliers to crimp Oetiker clamps. Oetiker clamp crimp must point up, away from top of fuel pump module and abrasion sleeve must be positioned over Oetiker clamp.
5. Connect electrical connector to top of fuel pump module. Ensure grey locking tab is pulled out before connecting. Push connector onto terminal until a click is heard, then push in grey locking tab to lock connector.
6. Install fuel pump module to baffle with screws. Torque screws to 9.2 N·m (81 in. lb.).
7. Connect vent hose to top of fuel pump module.
8. If equipped, install lift fuel pump (pulse or mechanical) and lines as an assembly. Route pulse line through large clamp on valve cover. Secure clamp with pulse line with outer baffle screw. Connect pulse line to crankcase vacuum fitting if engine and position clamp to secure (if engine has a pulse lift fuel pump).
9. Install lift fuel pump to bracket on housing using screws. Torque to M6 screws to 7.3 N·m (68 in. lb.) into new holes or 6.2 N·m (55 in. lb.) into used holes.
10. Connect in-line 10 micron EFI fuel filter and hose to inlet barb of lift fuel pump and secure with spring clamp. Connect fuel line to lift pump outlet and secure with spring clamp.

ECH EFI

1. Install lift fuel pump (pulse or mechanical) and lines as an assembly. Connect pulse line to crankcase vacuum fitting if engine has a pulse lift fuel pump.
2. Install lift fuel pump to bracket on housing using screws. Torque to M6 screws to 7.3 N·m (68 in. lb.) into new holes or 6.2 N·m (55 in. lb.) into used holes.
3. Connect in-line 10 micron EFI fuel filter and hose to inlet barb of lift fuel pump and secure with spring clamp.
4. Install fuel pump module baffle to crankcase using screws. Torque screws to 11.9 N·m (105 in. lb.).
5. Push high pressure fuel line connector onto fuel pump module fitting.
6. If Oetiker clamp was cut to remove inlet fuel line, slide a new Oetiker clamp onto fuel line and connect fuel line. Only use an Oetiker clamp pliers to crimp Oetiker clamps. Oetiker clamp crimp must point up, away from top of fuel pump module and abrasion sleeve must be positioned over Oetiker clamp.
7. Connect electrical connector to top of fuel pump module. Ensure grey locking tab is pulled out before connecting. Push connector onto terminal until a click is heard, then push in grey locking tab to lock connector.
8. Install fuel pump module to baffle with screws. Torque screws to 9.2 N·m (81 in. lb.).

Install External Governor Control (ECH EFI) (if equipped)

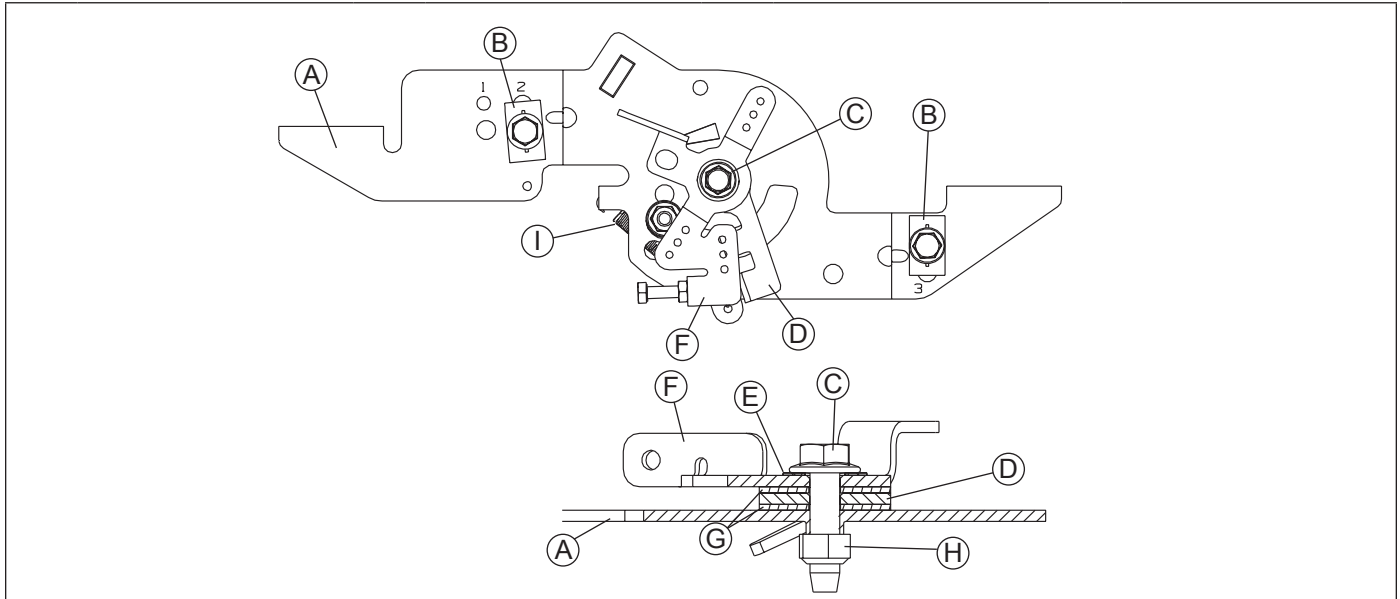

A	Speed Control Bracket	B	Cable Clamp	C	Screw	D	Throttle Actuator Lever (bottom)
E	Spring Washer	F	Throttle Control Lever (top)	G	Flat Washer	H	Nut
I	Return Spring						

1. Install governor lever onto governor cross shaft.
2. Make sure throttle linkage, linkage spring, and black linkage bushing are connected to governor lever and to throttle lever on throttle body.

Reassembly

	⚠ WARNING	Before working on engine or equipment, disable engine as follows: 1) Disconnect spark plug lead(s). 2) Disconnect negative (-) battery cable from battery.
	Accidental Starts can cause severe injury or death. Disconnect and ground spark plug lead(s) before servicing.	

External Engine Components

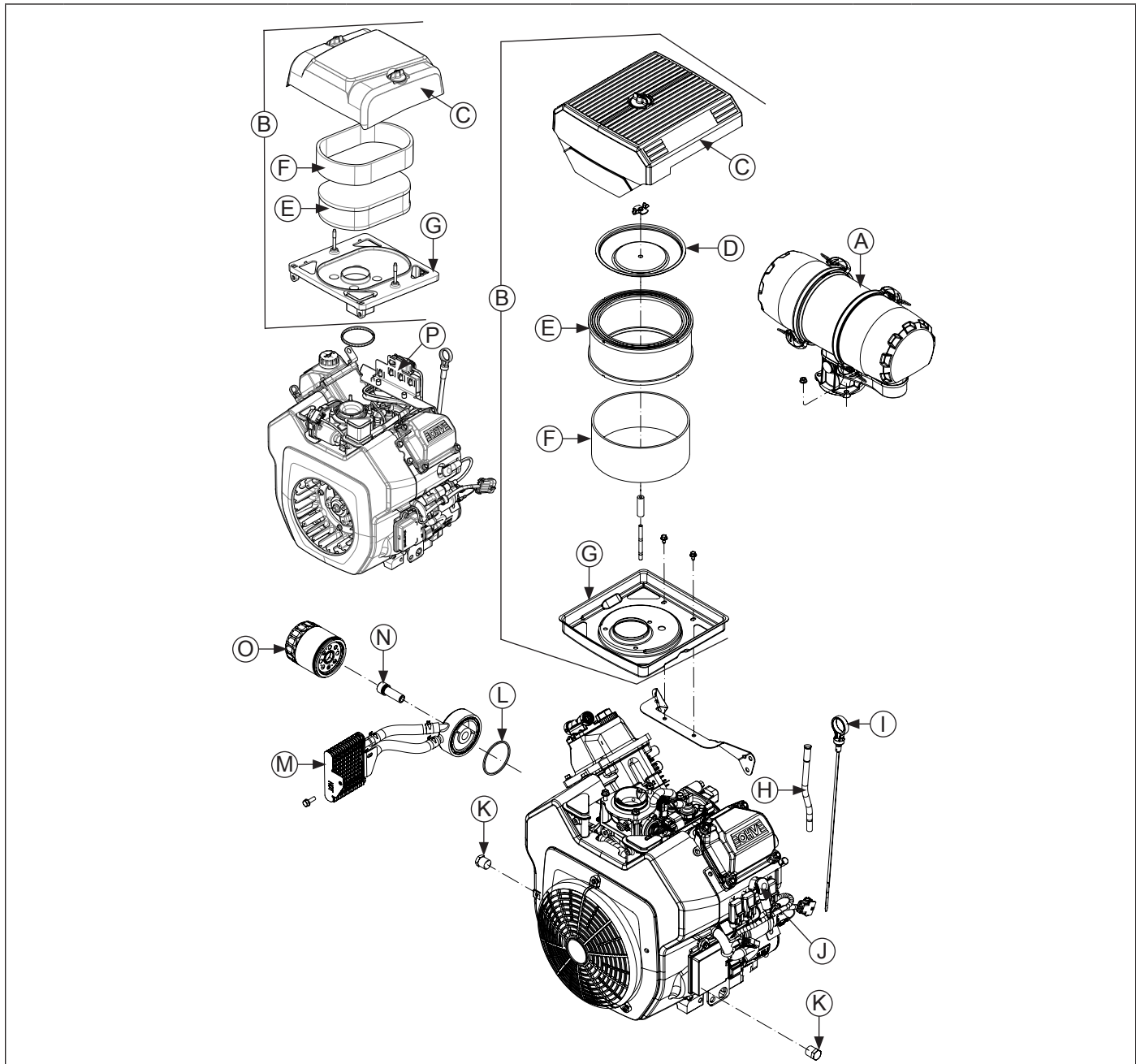

A	Heavy-Duty Air Cleaner	B	Low-Profile Air Cleaner	C	Low-Profile Air Cleaner Cover	D	Element Cover
E	Paper Element	F	Precleaner	G	Low-Profile Air Cleaner Base	H	Dipstick Tube
I	Dipstick	J	Spark Plug Lead	K	Oil Drain Plug	L	O-ring
M	Oil Cooler	N	Nipple	O	Oil Filter	P	LPAC Support Bracket

Install Throttle Control Panel (if equipped)

NOTE: To identify various parts and assembly of throttle control panel, refer to External Governor Control Components.

1. Secure throttle control panel to crankcase with thread forming screws.
2. Attach governor spring to previously marked hole on governor lever.

Install Air Cleaner Assembly

Refer to Air Cleaner/Intake Air for air cleaner reassembly procedure.

Heavy-Duty Air Cleaner

1. Install air cleaner assembly onto throttle body mounting studs. Secure with nuts and screws. Torque nuts to 7.4-9.0 N·m (65.5-80 in. lb.) and torque screws to 4.6-6.9 N·m (41-61 in. lb.).

Low-Profile Air Cleaner ETB ECH EFI

1. Verify O-ring is present in air cleaner base. Position base on electronic throttle body.
2. Install screws securing base to LPAC support bracket (with fuses) to finger tight.
3. Install nuts securing base to throttle body. Torque nuts to 8.3 N·m (73 in. lb.).
4. Then torque screws securing base to LPAC support bracket to 8.3 N·m (73 in. lb.).

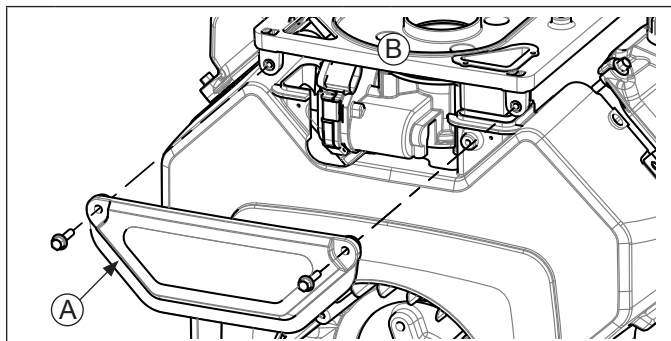

A	ETB Cover	B	Air Cleaner Base
----------	-----------	----------	------------------

5. Install ETB cover to air cleaner base. Torque screws to 5.6 N·m (50 in. lb.).
6. Install air cleaner components as described in Air Cleaner/Intake.

Low-Profile Air Cleaner

1. Verify O-ring is present around machined O.D. of throttle body and place air cleaner base onto throttle body studs. Secure air cleaner base using nuts. Attach air cleaner base bracket to cylinder heads with screws behind any control panel or bracket. Attach air cleaner base to lower bracket with 2 M5 screws through lower section of base. Torque nuts to 8.3 N·m (73 in. lb.), and 2 lower M5 mounting screws (when applicable) to 4.0 N·m (35 in. lb.).
2. Install air cleaner components as described in Air Cleaner/Intake.

Setting Initial Governor Adjustment (if equipped)

ECH EFI

1. Move governor lever toward throttle body as far as it will go (wide-open throttle) and hold in position.
2. Insert a nail into hole on cross shaft and rotate shaft counterclockwise as far as it will turn, then torque hex nut to 7.1 N·m (63 in. lb.).

BOSCH EFI (CH26, CH735, CH745)

Refer to EFI SYSTEM-BOSCH section for Initial Governor Adjustment procedure.

Install Muffler (if equipped)

Oxygen Sensor Wire Detail

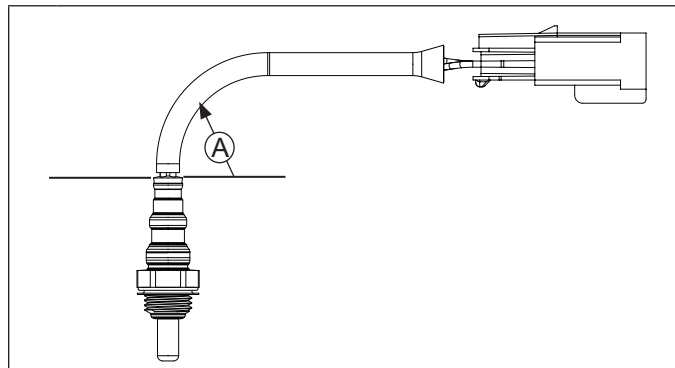

A Keep a minimum of 25 mm (1.0 in.) radius at grommet.

NOTE: Always route harness away from hot exhaust and away from moving parts.

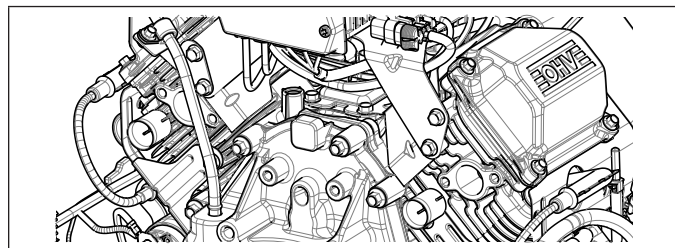

1. Install port liners (if equipped), slotted end first, into exhaust ports until finger tight. (Exhaust components will press them to final depth.) Install exhaust gaskets and muffler on exhaust studs.
2. Install muffler and attaching hardware to muffler bracket. Install nuts on exhaust studs.
3. Torque nuts to 27.8 N·m (246 in. lb.). Torque screws to 9.9 N·m (88 in. lb.).
4. Install oxygen sensor and secure using appropriate torque.
Torque smaller 14 mm (9/16 in.) wrench size sensor to 18 N·m (159 in. lb.).
Torque larger 22 mm (7/8 in.) wrench size sensor to 50.1 N·m (37 ft. lb.).
5. Connect sensor to wire harness and secure to fuse holder bracket.

Reassembly

Install Oil Cooler (if equipped)

1. Secure adapter to closure plate with oil filter nipple. Torque oil filter nipple to 28.5 N·m (21 ft. lb.).
2. Verify all fuel and vent hoses are routed properly and not pinched. Install 2 screws securing oil cooler to blower housing. Torque screw between hoses to 2.3 N·m (20 in. lb.) and outer screw to 2.8 N·m (25 in. lb.).

Install Oil Filter and Fill Crankcase with Oil

NOTE: If testing oil pressure after completing reassembly, install oil pressure adapter instead of oil filter.

NOTE: Make sure oil drain plug is installed and torqued to specification to prevent oil leakage.

NOTE: Some models are equipped with an oil drain valve.

1. Install oil drain plug. Torque plug to 13.6 N·m (10 ft. lb.).
2. Place new filter in shallow pan with open end up. Fill with new oil until oil reaches bottom of threads. Allow 2 minutes for oil to be absorbed by filter material.
3. Apply a thin film of clean oil to rubber gasket on oil filter.
4. Refer to instructions on oil filter for proper installation.
5. Fill crankcase with new oil. Level should be at top of indicator on dipstick.
6. Reinstall oil fill cap/dipstick and tighten securely.

Connect Spark Plug Leads

Connect leads to spark plugs.

Prepare Engine for Operation (ECH EFI)

NOTE: If ECU, throttle body, TPS or fuel pump module were replaced, an ECU Reset and TPS Learn is required. Refer to Electronic Fuel Injection (EFI) System for ECU Reset and TPS Learn procedure.

Engine is now completely reassembled. Before starting or operating engine, be sure to do following.

1. Make sure all hardware is tightened securely.
2. Make sure oil drain plugs, Oil Sentry™ pressure switch, and a new oil filter are installed.
3. Verify crankcase has been filled with correct amount, weight, and type of oil. Refer to oil recommendations and procedures in Maintenance, Specifications, and Lubrication System.
4. Adjust idle speed adjusting screw as necessary. Refer to Fuel System.
5. Turn on fuel supply.

Sensitivity Adjustment (if equipped)

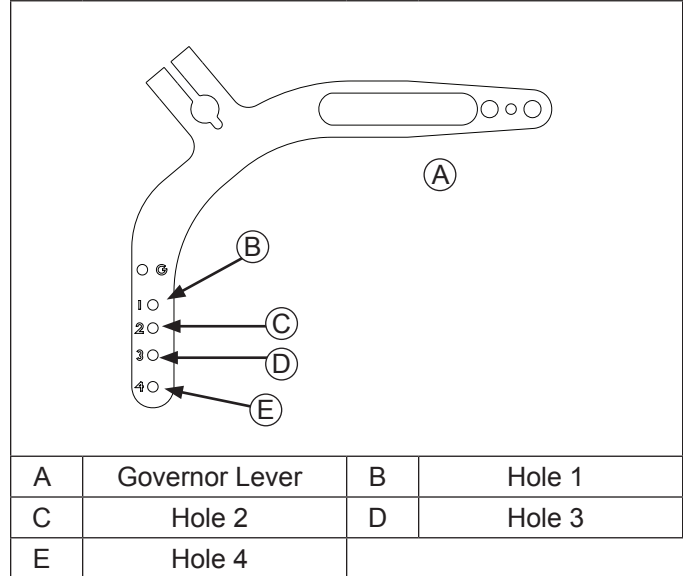

Governor sensitivity is adjusted by repositioning governor spring in holes of governor lever. If speed surging occurs with a change in engine load, governor is set too sensitive. If a big drop in speed occurs when normal load is applied, governor should be set for greater sensitivity. Adjust as follows:

1. To increase sensitivity, move spring closer to governor lever pivot point.
2. To decrease sensitivity, move spring away from governor lever pivot point.

Testing Engine

ECH EFI

It is recommended engine be operated on a test stand or bench prior to installation in piece of equipment.

1. Set engine up on a test stand. Start engine, inspect for leaks and check to make certain oil pressure (20 psi or more) is present. Run engine at idle for 2-3 minutes, then 5-6 minutes more between idle and midrange.
2. Adjust idle speed screw located on throttle body as necessary. Standard idle speed setting for EFI engines is 1500 RPM, but certain applications might require a different setting.
3. Adjust high-speed stop as necessary located on control panel (if so equipped). Make sure maximum engine speed does not exceed 4200 RPM (no load).

ETB ECH EFI

Engines equipped with an electronic throttle body (ETB) cannot be tested on a test stand or bench. Install engine in application.



1P24 690 01



6 50531 96541 7