

Command

SH255, SH265, SH270

Service Manual

Kohler Engines
is now Rehlko.

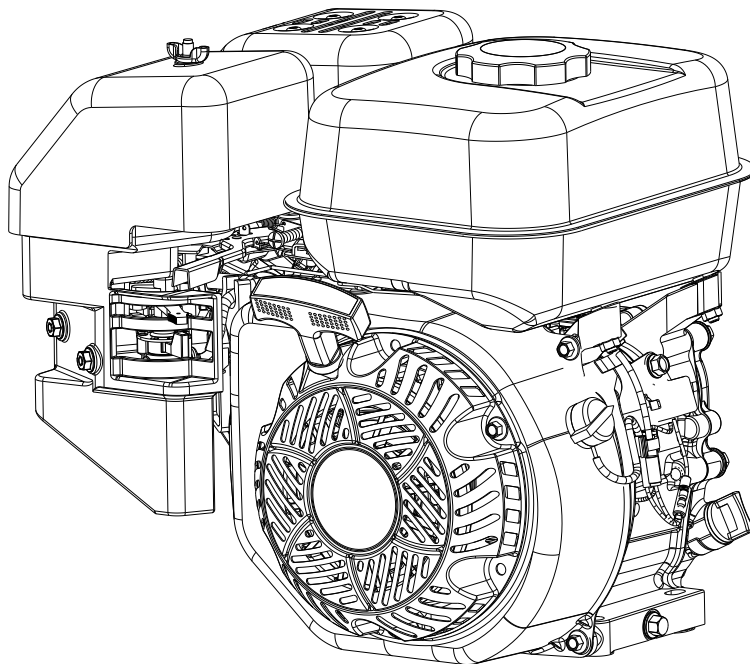

2	Safety
3	Maintenance
5	Specifications
12	Tools and Aids
15	Troubleshooting
19	Air Cleaner/Intake
20	Fuel System
24	Governor System
25	Lubrication System
26	Electrical System
30	Starter System
33	Disassembly/Inspection and Service
43	Reassembly

IMPORTANT: Read all safety precautions and instructions carefully before operating equipment. Refer to operating instruction of equipment that this engine powers.

Ensure engine is stopped and level before performing any maintenance or service.

Safety

SAFETY PRECAUTIONS

⚠ WARNING: A hazard that could result in death, serious injury, or substantial property damage.

⚠ CAUTION: A hazard that could result in minor personal injury or property damage.

NOTE: is used to notify people of important installation, operation, or maintenance information.

	⚠ WARNING
	Explosive Fuel can cause fires and severe burns. Do not fill fuel tank while engine is hot or running.
Gasoline is extremely flammable and its vapors can explode if ignited. Store gasoline only in approved containers, in well ventilated, unoccupied buildings, away from sparks or flames. Spilled fuel could ignite if it comes in contact with hot parts or sparks from ignition. Never use gasoline as a cleaning agent.	

	⚠ WARNING
	Rotating Parts can cause severe injury. Stay away while engine is in operation.
Keep hands, feet, hair, and clothing away from all moving parts to prevent injury. Never operate engine with covers, shrouds, or guards removed.	

	⚠ WARNING
	Carbon Monoxide can cause severe nausea, fainting or death. Avoid inhaling exhaust fumes. Never run engine indoors or in enclosed spaces.
Engine exhaust gases contain poisonous carbon monoxide. Carbon monoxide is odorless, colorless, and can cause death if inhaled.	

	⚠ WARNING
	Accidental Starts can cause severe injury or death. Disconnect and ground spark plug lead(s) before servicing.
Before working on engine or equipment, disable engine as follows: 1) Disconnect spark plug lead(s). 2) Disconnect negative (-) battery cable from battery.	

	⚠ WARNING
	Hot Parts can cause severe burns. Do not touch engine while operating or just after stopping.
Never operate engine with heat shields or guards removed.	



	⚠ WARNING
	Cleaning Solvents can cause severe injury or death. Use only in well ventilated areas away from ignition sources.
Carburetor cleaners and solvents are extremely flammable. Follow cleaner manufacturer's warnings and instructions on its proper and safe use. Never use gasoline as a cleaning agent.	

	⚠ CAUTION
	Electrical Shock can cause injury. Do not touch wires while engine is running.

	⚠ CAUTION
	Damaging Crankshaft and Flywheel can cause personal injury.
Using improper procedures can lead to broken fragments. Broken fragments could be thrown from engine. Always observe and use precautions and procedures when installing flywheel.	

	⚠ WARNING
	Uncoiling Spring can cause severe injury. Wear safety goggles or face protection when servicing retractable starter.
Retractable starters contain a powerful, recoil spring that is under tension. Always wear safety goggles when servicing retractable starters and carefully follow instructions in Retractable Starter for relieving spring tension.	

MAINTENANCE INSTRUCTIONS

  	⚠ WARNING	Before working on engine or equipment, disable engine as follows: 1) Disconnect spark plug lead(s). 2) Disconnect negative (-) battery cable from battery.
	Accidental Starts can cause severe injury or death. Disconnect and ground spark plug lead(s) before servicing.	

Normal maintenance, replacement or repair of emission control devices and systems may be performed by any repair establishment or individual; however, warranty repairs must be performed by a Rehlko authorized dealer.

MAINTENANCE SCHEDULE

After first 5 Hours

<ul style="list-style-type: none"> Change oil (NOT required if using Xtended Life PRO 10W-50 full-synthetic oil). 	Lubrication System
--	--------------------

Every 50 Hours or Annually

<ul style="list-style-type: none"> Service/replace dual-element precleaner. 	Air Cleaner/Intake
--	--------------------

Every 100 Hours or Annually¹

<ul style="list-style-type: none"> Clean low-profile air cleaner element. 	Air Cleaner/Intake
<ul style="list-style-type: none"> Replace dual-element air cleaner element. 	Air Cleaner/Intake
<ul style="list-style-type: none"> Change oil. 	Lubrication System
<ul style="list-style-type: none"> Clean cooling areas. 	Air Cleaner/Intake
<ul style="list-style-type: none"> Clean spark arrestor (if equipped). 	
<ul style="list-style-type: none"> Replace fuel filter (if equipped). 	

Every 100 Hours²

<ul style="list-style-type: none"> Check and adjust valve clearance when engine is cold. 	Reassembly
---	------------

Every 125 Hours or Annually¹

<ul style="list-style-type: none"> Replace spark plug and set gap. 	Electrical System
---	-------------------

Every 200 Hours²

<ul style="list-style-type: none"> Replace fuel line. 	Fuel System
--	-------------

Every 300 Hours

<ul style="list-style-type: none"> Replace low-profile air cleaner element. 	Air Cleaner/Intake
--	--------------------

Every 300 Hours³

<ul style="list-style-type: none"> Change oil (Xtended Life PRO 10W-50 oil only). 	Lubrication System
--	--------------------

¹ Perform these procedures more frequently under severe, dusty, dirty conditions.

² Have a Rehlko authorized dealer perform this service.

³ Option only if using Xtended Life PRO 10W-50 oil.

REPAIRS/SERVICE PARTS

Rehlko genuine service parts can be purchased from Rehlko authorized dealers. To find a local Rehlko authorized dealer visit Engines.rehlko.com or call 1-800-544-2444 (U.S. and Canada).

Maintenance

OIL RECOMMENDATIONS

All-season Xtended Life PRO 10W-50 Synthetic Oil is the ideal oil for Rehlko engines. It is specifically formulated to extend the oil change interval to 300 Hours. Contact your Rehlko authorized dealer for availability.

300-Hour oil change intervals are exclusive to and only authorized on Rehlko engines that utilize the Xtended Life PRO 10W-50 Synthetic Oil. Alternative engine oils may be used with Rehlko engines but require 100-Hour oil change intervals for proper maintenance. Oil must be API (American Petroleum Institute) service class SJ or higher. Select viscosity based on air temperature at time of operation as shown below.

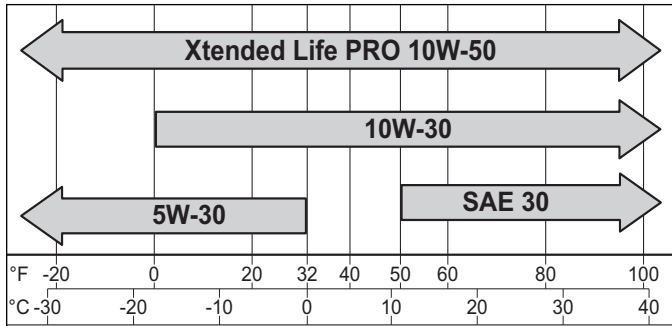

FUEL RECOMMENDATIONS

	WARNING
	Explosive Fuel can cause fires and severe burns. Do not fill fuel tank while engine is hot or running.
Gasoline is extremely flammable and its vapors can explode if ignited. Store gasoline only in approved containers, in well ventilated, unoccupied buildings, away from sparks or flames. Spilled fuel could ignite if it comes in contact with hot parts or sparks from ignition. Never use gasoline as a cleaning agent.	

NOTE: E15, E20 and E85 are NOT approved and should NOT be used; effects of old, stale or contaminated fuel are not warrantable.

Fuel must meet these requirements:

- Clean, fresh, unleaded gasoline.
- Octane rating of 87 (R+M)/2 or higher.
- Research Octane Number (RON) 90 octane minimum.
- Gasoline up to 10% ethyl alcohol, 90% unleaded is acceptable.
- Methyl Tertiary Butyl Ether (MTBE) and unleaded gasoline blend (max 15% MTBE by volume) are approved.
- Do not add oil to gasoline.
- Do not overfill fuel tank.
- Do not use gasoline older than 30 days.

STORAGE

If engine will be out of service for 2 months or more follow procedure below.

1. Add Xtended Life PRO 10W-50 Series fuel treatment or equivalent to fuel tank. Run engine 2-3 minutes to get stabilized fuel into fuel system (failures due to untreated fuel are not warrantable).
2. Change oil while engine is still warm from operation (NOT required if using Xtended Life PRO 10W-50 full-synthetic oil). Remove spark plug(s) and pour about 1 oz. of engine oil into cylinder(s). Replace spark plug(s) and crank engine slowly to distribute oil.
3. Disconnect negative (-) battery cable.
4. Store engine in a clean, dry place.

Engine Dimensions

Dimensions in millimeters.
Inch equivalents shown in [].

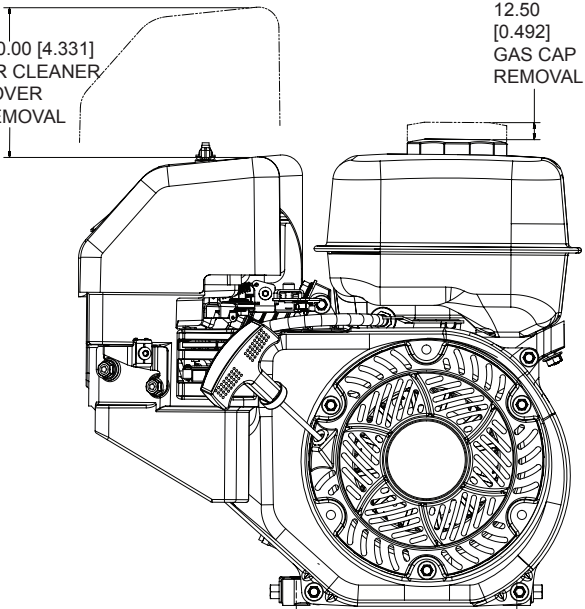
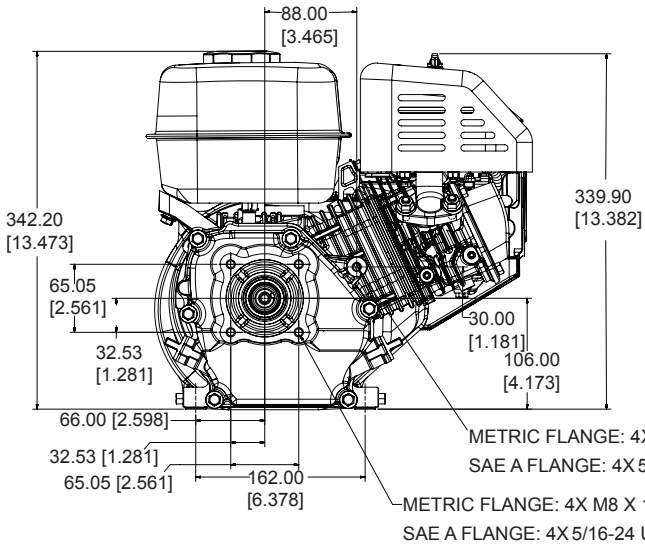
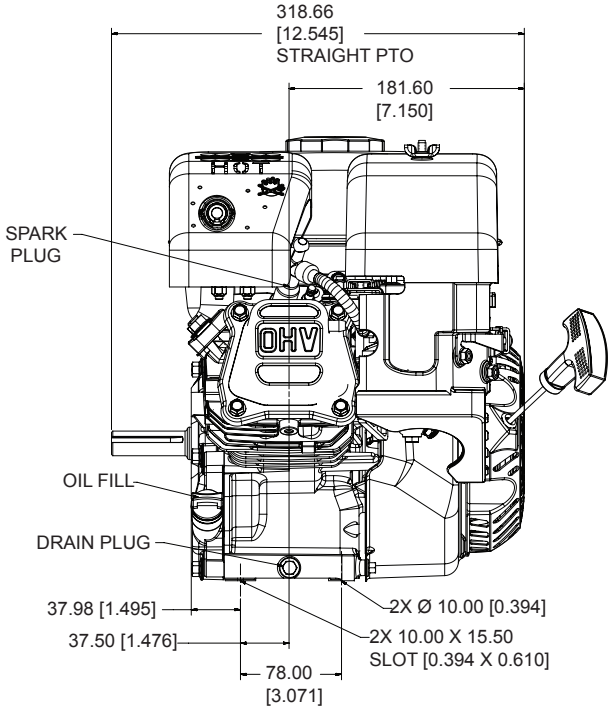
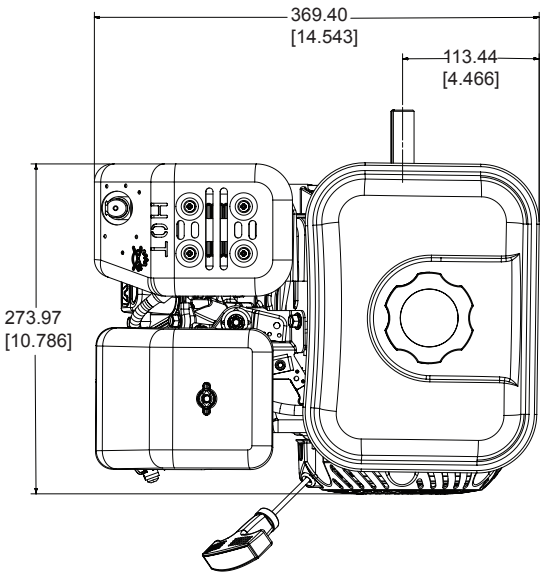

Specifications

ENGINE IDENTIFICATION NUMBERS

Rehiko engine identification numbers (model, specification and serial) should be referenced for efficient repair, ordering correct parts, and engine replacement.

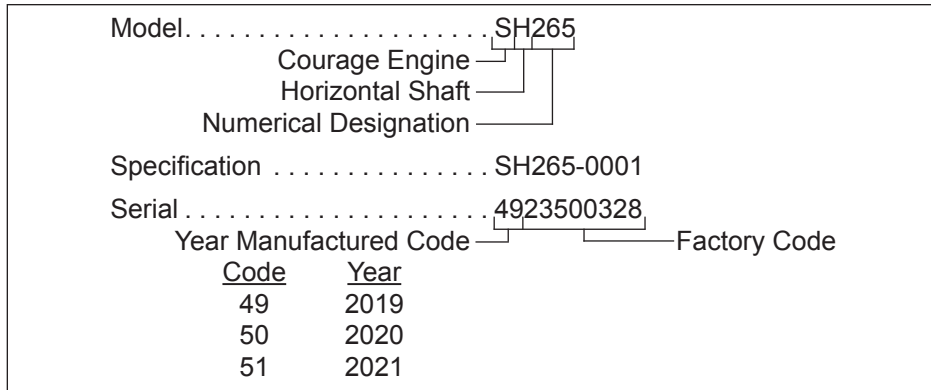

GENERAL SPECIFICATIONS^{4,7}

SH255, SH265, SH270

Bore	68 mm (2.7 in.)
Stroke	54 mm (2.1 in.)
Displacement	196 cc (12.0 cu. in.)
Oil Capacity (refill)	0.6 L (0.63 U.S. qt.)
Maximum Angle of Operation (@ full oil level) ⁵	25°

TORQUE SPECIFICATIONS^{4,6}

SH255, SH265, SH270

Air Cleaner

Mounting Screw (into intake manifold)	8 N·m (70.8 in. lb.)
---------------------------------------	----------------------

Blower Housing and Sheet Metal

M6 Shoulder Screw	10 N·m (88.5 in. lb.)
M6 Nut	8 N·m (70.8 in. lb.)

Carburetor

Stud	10 N·m (88.5 in. lb.)
Primary Nut	8 N·m (70.8 in. lb.)
Secondary Nut	10 N·m (88.5 in. lb.)
Intake Cover Nut	4 N·m (35.4 in. lb.)

Connecting Rod

Cap Fastener (torque in increments)	12 N·m (106 in. lb.)
-------------------------------------	----------------------

Crankcase

Oil Drain Plug	18 N·m (13 ft. lb.)
Closure Plate Screw	24 N·m (212 in. lb.)

Cylinder Head

Fastener (torque in 2 increments)	first to 12 N·m (106 in. lb.) finally to 24 N·m (212 in. lb.)
-----------------------------------	--

⁴ Values are in Metric units. Values in parentheses are English equivalents.

⁵ Exceeding maximum angle of operation may cause engine damage from insufficient lubrication.

⁶ Lubricate threads with engine oil prior to assembly.

⁷ Any and all horsepower (hp) references by Rehiko are Certified Power Ratings and per SAE J1940 & J1995 hp standards. Details on Certified Power Ratings can be found at Engines.rehiko.com.

TORQUE SPECIFICATIONS^{4,6}

SH255, SH265, SH270

Flywheel

Retaining Nut	74 N·m (655 in. lb.)
---------------	----------------------

Fuel Tank

Mounting Nut	24 N·m (212 in. lb.)
Mounting Screw	24 N·m (212 in. lb.)
Inlet Fitting	1.5 N·m (13.3 in. lb.)

Governor

Arm Nut	10 N·m (88.5 in. lb.)
Throttle Control Lever Nut	4.5-6 N·m (40-53 in. lb.)

Ignition

Spark Plug	27 N·m (20 ft. lb.)
Module Fastener	8 N·m (70.8 in. lb.)
Module Screw	10 N·m (88.5 in. lb.)
Oil Sentry™ Module Screw	8 N·m (70.8 in. lb.)

Muffler

M8 Exhaust Screw	24 N·m (212 in. lb.)
M6 Muffler Shield Screw	8 N·m (70.8 in. lb.)
M4 Muffler Shield Screw	2 N·m (17.7 in. lb.)
M5 Spark Arrestor Screw	3.5 N·m (31 in. lb.)

Retractable Starter

Cover Screw	5.4 N·m (47.8 in. lb.)
Screw	10 N·m (88.5 in. lb.)

Rocker Arm

Stud	13.6 N·m (120 in. lb.)
Pivot Jam Nut	10 N·m (88.5 in. lb.)

Valve Cover

Fastener	8 N·m (70.8 in. lb.)
----------	----------------------

⁴ Values are in Metric units. Values in parentheses are English equivalents.

⁶ Lubricate threads with engine oil prior to assembly.

Specifications

CLEARANCE SPECIFICATIONS⁴

SH255, SH265, SH270

Camshaft

End Play	0.025/0.602 mm (0.0010/0.0237 in.)
Running Clearance	0.016/0.052 mm (0.0006/0.0020 in.)
Bore I.D. New Max. Wear Limit	14.000/14.018 mm (0.5512/0.5519 in.) 14.048 mm (0.5531 in.)

Connecting Rod

Crankpin End I.D. @ 21°C (70°F) New Max. Wear Limit	30.021/30.026 mm (1.1819/1.1821 in.) 30.08 mm (1.184 in.)
Connecting Rod-to-Crankpin Running Clearance New Max. Wear Limit	0.041/0.051 mm (0.002/0.002 in.) 0.12 mm (0.005 in.)
Connecting Rod-to-Crankpin Side Clearance New Max. Wear Limit	0.11-0.65 mm (0.004-0.026 in.) 1.10 mm (0.043 in.)
Connecting Rod-to-Piston Pin Running Clearance	0.01/0.027 mm (0.0004/0.0011 in.)
Piston Pin End I.D. @ 21°C (70°F) New Max. Wear Limit	18.010/18.015 mm (0.709/0.709 in.) 18.08 mm (0.712 in.)

Crankcase

Governor Cross Shaft Bore I.D. New Max. Wear Limit	6.000/6.018 mm (0.2362/0.2369 in.) 6.037 mm (0.2377 in.)
--	---

Crankshaft

End Play (free)	0.025/0.703 mm (0.0010/0.028 in.)
Ball Bearing	0.003/0.25 mm (0.0001/0.0010 in.)
Bore (in crankcase) New, without Main Bearing	51.961/51.991 mm (2.0457/2.0469 in.)
Bore (in closure plate) New, without Main Bearing	51.961/51.991 mm (2.0457/2.0469 in.)
Flywheel End Main Bearing Journal O.D. O.D.-New O.D.-Max. Wear Limit Max. Taper Max. Out-of-Round	24.975/24.989 mm (0.9833/0.9838 in.) 24.95 mm (0.9823 in.) 0.025 mm (0.0010 in.) 0.025 mm (0.0010 in.)
Closure Plate End Main Bearing Journal O.D. O.D.-New O.D.-Max. Wear Limit Max. Taper Max. Out-of-Round	24.975/24.989 mm (0.9833/0.9838 in.) 24.95 mm (0.9823 in.) 0.025 mm (0.0010 in.) 0.025 mm (0.0010 in.)
Connecting Rod Journal O.D. O.D.-New O.D.-Max. Wear Limit Max. Taper Max. Out-of-Round Width	28.970-29.980 mm (1.1406-1.1803 in.) 29.920 mm (1.1779 in.) 0.025 mm (0.0010 in.) 0.025 mm (0.0010 in.) 25.01-25.15 mm (0.9846-0.9902 in.)
Runout (either end)	0.025 mm (0.0010 in.)
Main Bearing I.D. (Crankcase/Closure Plate) New (installed)	24.994/25.000 mm (0.9840/0.9842 in.)

⁴ Values are in Metric units. Values in parentheses are English equivalents.

CLEARANCE SPECIFICATIONS⁴

SH255, SH265, SH270

Cylinder Bore

Bore I.D. New Max. Wear Limit Max. Out-of-Round Max. Taper	68.0125/68.0275 mm (2.6777/2.6782 in.) 70.200 mm (2.764 in.) 12.7 microns (0.0005 in.) 12.7 microns (0.0005 in.)
--	---

Cylinder Head

Max. Out-of-Flatness	0.1 mm (0.0039 in.)
----------------------	---------------------

Governor

Governor Cross Shaft-to-Crankcase Running Clearance	0.013/0.075 mm (0.0005/0.0029 in.)
Governor Cross Shaft O.D. New Max. Wear Limit	5.95/5.98 mm (0.2342/0.2354 in.) 5.85 mm (0.2303 in.)
Governor Gear Shaft-to-Governor Gear Running Clearance	0.09/0.19 mm (0.0035/0.0074 in.)
Governor Gear Shaft O.D. New Max. Wear Limit	6.028/6.043 mm (0.2373/0.2379 in.) 6.018 mm (0.2369 in.)

Ignition

Spark Plug Gap	0.76 mm (0.030 in.)
Module Air Gap	0.254 mm (0.0100 in.)

Piston, Piston Rings, and Piston Pin

Piston-to-Piston Pin Running Clearance	0.009/0.016 mm (0.0003/0.0006 in.)
Piston Pin Bore I.D. New Max. Wear Limit	18.004/18.005 mm (0.7088/0.7089 in.) 18.05 mm (0.7106 in.)
Piston Pin O.D. New Max. Wear Limit	17.992/17.995 mm (0.7083/0.7084 in.) 17.95 mm (0.7067 in.)
Top and Center Compression Ring Side Clearance New Bore Used Bore (max.)	0.04 mm (0.002 in.) 0.15 mm (0.006 in.)
Top and Center Compression Ring End Gap New Bore Used Bore (max.)	0.325 mm/0.4 (0.013/0.016 in.) 1.00 mm (0.039 in.)
Top and Center Compression Ring Width New Bore Used Bore (max.)	1.5/1.51 mm (0.059/0.059 in.) 1.37 mm (0.054 in.)
Oil Control Ring-to-Groove Side Clearance	0.06/0.18 mm (0.0023/0.0071 in.)
Piston Thrust Face O.D. ⁸ New Max. Wear Limit	67.975/67.985 mm (2.6762/2.6766 in.) 67.85 mm (2.6712 in.)
Piston Thrust Face-to-Cylinder Bore Running Clearance New	0.057/0.075 mm (0.0022/0.0029 in.)

⁴ Values are in Metric units. Values in parentheses are English equivalents.

⁸ Measure 15 mm (0.5905 in.) above bottom of piston skirt at right angles to piston pin.

Specifications

CLEARANCE SPECIFICATIONS⁴



SH255, SH265, SH270

Valves and Valve Lifters





Intake Valve Lash	0.1 mm (0.0040 in.)
Exhaust Valve Lash	0.15 mm (0.0060 in.)
Intake Valve Stem-to-Valve Guide Running Clearance	0.020/0.044 mm (0.008/0.0017 in.)
Exhaust Valve Stem-to-Valve Guide Running Clearance	0.030/0.054 mm (0.0011/0.0021 in.)
Intake Valve Stem O.D. New Max. Wear Limit	5.480 mm (0.2157 in.) 5.32 mm (0.2094 in.)
Exhaust Valve Stem O.D. New Max. Wear Limit	5.47 mm (0.2153 in.) 5.305 mm (0.2088 in.)
Intake Valve Stem to Guide New Max. Wear Limit	0.024/0.039 mm (0.001/0.002 in.) 0.10 mm (0.0004 in.)
Exhaust Valve Stem to Guide New Max. Wear Limit	0.098/0.112 mm (0.0038/0.0044 in.) 0.12 mm (0.0005 in.)
Valve Guide Reamer Size Standard Intake Standard Exhaust	5.506 mm (0.2168 in.) 5.506 mm (0.2168 in.)
Valve Seat Width	0.800/2.00 mm (0.0315/0.787 in.)
Nominal Valve Face Angle	30°, 45°, 60°

⁴ Values are in Metric units. Values in parentheses are English equivalents.

GENERAL TORQUE VALUES

English Fastener Torque Recommendations for Standard Applications				
Bolts, Screws, Nuts and Fasteners Assembled Into Cast Iron or Steel				Grade 2 or 5 Fasteners Into Aluminum
Size	 Grade 2	 Grade 5	 Grade 8	
Tightening Torque: N·m (in. lb.) ± 20%				
8-32	2.3 (20)	2.8 (25)	—	2.3 (20)
10-24	3.6 (32)	4.5 (40)	—	3.6 (32)
10-32	3.6 (32)	4.5 (40)	—	—
1/4-20	7.9 (70)	13.0 (115)	18.7 (165)	7.9 (70)
1/4-28	9.6 (85)	15.8 (140)	22.6 (200)	—
5/16-18	17.0 (150)	28.3 (250)	39.6 (350)	17.0 (150)
5/16-24	18.7 (165)	30.5 (270)	—	—
3/8-16	29.4 (260)	—	—	—
3/8-24	33.9 (300)	—	—	—

Tightening Torque: N·m (ft. lb.) ± 20%				
5/16-24	—	—	40.7 (30)	—
3/8-16	—	47.5 (35)	67.8 (50)	—
3/8-24	—	54.2 (40)	81.4 (60)	—
7/16-14	47.5 (35)	74.6 (55)	108.5 (80)	—
7/16-20	61.0 (45)	101.7 (75)	142.5 (105)	—
1/2-13	67.8 (50)	108.5 (80)	155.9 (115)	—
1/2-20	94.9 (70)	142.4 (105)	223.7 (165)	—
9/16-12	101.7 (75)	169.5 (125)	237.3 (175)	—
9/16-18	135.6 (100)	223.7 (165)	311.9 (230)	—
5/8-11	149.5 (110)	244.1 (180)	352.6 (260)	—
5/8-18	189.8 (140)	311.9 (230)	447.5 (330)	—
3/4-10	199.3 (147)	332.2 (245)	474.6 (350)	—
3/4-16	271.2 (200)	440.7 (325)	637.3 (470)	—

Metric Fastener Torque Recommendations for Standard Applications						
Size	Property Class					Noncritical Fasteners Into Aluminum
	 4.8	 5.8	 8.8	 10.9	 12.9	
Tightening Torque: N·m (in. lb.) ± 10%						
M4	1.2 (11)	1.7 (15)	2.9 (26)	4.1 (36)	5.0 (44)	2.0 (18)
M5	2.5 (22)	3.2 (28)	5.8 (51)	8.1 (72)	9.7 (86)	4.0 (35)
M6	4.3 (38)	5.7 (50)	9.9 (88)	14.0 (124)	16.5 (146)	6.8 (60)
M8	10.5 (93)	13.6 (120)	24.4 (216)	33.9 (300)	40.7 (360)	17.0 (150)
Tightening Torque: N·m (ft. lb.) ± 10%						
M10	21.7 (16)	27.1 (20)	47.5 (35)	66.4 (49)	81.4 (60)	33.9 (25)
M12	36.6 (27)	47.5 (35)	82.7 (61)	116.6 (86)	139.7 (103)	61.0 (45)
M14	58.3 (43)	76.4 (56)	131.5 (97)	184.4 (136)	219.7 (162)	94.9 (70)

Torque Conversions	
N·m = in. lb. x 0.113	in. lb. = N·m x 8.85
N·m = ft. lb. x 1.356	ft. lb. = N·m x 0.737

Tools and Aids

Certain quality tools are designed to help you perform specific disassembly, repair, and reassembly procedures. By using these tools, you can properly service engines easier, faster, and safer! In addition, you'll increase your service capabilities and customer satisfaction by decreasing engine downtime.

Here is a list of tools and their source.

NOTE: Not all tools listed are required to service this engine.

SEPARATE TOOL SUPPLIERS

Rehiko Tools
Contact your local Rehiko source of supply.

SE Tools
415 Howard St.
Lapeer, MI 48446
Phone 810-664-2981
Toll Free 800-664-2981
Fax 810-664-8181

Design Technology Inc.
768 Burr Oak Drive
Westmont, IL 60559
Phone 630-920-1300
Fax 630-920-0011

TOOLS

Description	Source/Part No.
Alcohol Content Tester For testing alcohol content (%) in reformulated/oxygenated fuels.	Rehiko 25 455 11-S
Camshaft Endplay Plate For checking camshaft endplay.	SE Tools KLR-82405
Camshaft Seal Protector (Aegis) For protecting seal during camshaft installation.	SE Tools KLR-82417
Cylinder Leakdown Tester For checking combustion retention and if cylinder, piston, rings, or valves are worn. Individual component available: Adapter 12 mm x 14 mm (Required for leakdown test on XT-6 engines)	Rehiko 25 761 05-S Design Technology Inc. DTI-731-03
Dealer Tool Kit (Domestic) Complete kit of Rehiko required tools. Components of 25 761 39-S Ignition System Tester Cylinder Leakdown Tester Oil Pressure Test Kit Rectifier-Regulator Tester (120 V AC/60Hz)	Rehiko 25 761 39-S Rehiko 25 455 01-S Rehiko 25 761 05-S Rehiko 25 761 06-S Rehiko 25 761 20-S
Dealer Tool Kit (International) Complete kit of Rehiko required tools. Components of 25 761 42-S Ignition System Tester Cylinder Leakdown Tester Oil Pressure Test Kit Rectifier-Regulator Tester (240 V AC/50Hz)	Rehiko 25 761 42-S Rehiko 25 455 01-S Rehiko 25 761 05-S Rehiko 25 761 06-S Rehiko 25 761 41-S
Digital Vacuum/Pressure Tester For checking crankcase vacuum. Individual component available: Rubber Adapter Plug	Design Technology Inc. DTI-721-01 Design Technology Inc. DTI-721-10
Electronic Fuel Injection (EFI) Diagnostic Software For Laptop or Desktop PC.	Rehiko 25 761 23-S
EFI Service Kit For troubleshooting and setting up an EFI engine. Components of 24 761 01-S Fuel Pressure Tester Noid Light 90° Adapter Code Plug, Red Wire Code Plug, Blue Wire Shrader Valve Adapter Hose Wire Probe Set (2 pieces regular wire with clip; 1 piece fused wire) Hose Removal Tool, Dual Size/End (also sold as individual Rehiko tool)	Rehiko 24 761 01-S Design Technology Inc. DTI-019 DTI-021 DTI-023 DTI-027 DTI-029 DTI-037 DTI-031 DTI-033
Flywheel Puller For properly removing flywheel from engine.	SE Tools KLR-82408
Hose Removal Tool, Dual Size/End (also available in EFI Service Kit) Used to properly remove fuel hose from engine components.	Rehiko 25 455 20-S

TOOLS

Description	Source/Part No.
Hydraulic Valve Lifter Tool For removing and installing hydraulic lifters.	Rehiko 25 761 38-S
Ignition System Tester For testing output on all systems, including CD.	Rehiko 25 455 01-S
Inductive Tachometer (Digital) For checking operating speed (RPM) of an engine.	Design Technology Inc. DTI-110
Offset Wrench (K and M Series) For removing and reinstalling cylinder barrel retaining nuts.	Rehiko 52 455 04-S
Oil Pressure Test Kit For testing/verifying oil pressure on pressure lubricated engines.	Rehiko 25 761 06-S
Rectifier-Regulator Tester (120 volt current) Rectifier-Regulator Tester (240 volt current) For testing rectifier-regulators. Components of 25 761 20-S and 25 761 41-S CS-PRO Regulator Test Harness Special Regulator Test Harness with Diode	Rehiko 25 761 20-S Rehiko 25 761 41-S Design Technology Inc. DTI-031R DTI-033R
Spark Advance Module (SAM) Tester For testing SAM (ASAM and DSAM) on engines with SMART-SPARK™.	Rehiko 25 761 40-S
Starter Servicing Kit (All Starters) For removing and reinstalling drive retaining rings and brushes. Individual component available: Starter Brush Holding Tool (Solenoid Shift)	SE Tools KLR-82411 SE Tools KLR-82416
Triad/OHC Timing Tool Set For holding cam gears and crankshaft in timed position while installing timing belt.	Rehiko 28 761 01-S
Valve Guide Reamer (K and M Series) For properly sizing valve guides after installation.	Design Technology Inc. DTI-K828
Valve Guide Reamer O.S. (Command Series) For reaming worn valve guides to accept replacement oversize valves. Can be used in low-speed drill press or with handle below for hand reaming.	Rehiko 25 455 12-S
Reamer Handle For hand reaming using Rehiko 25 455 12-S reamer.	Design Technology Inc. DTI-K830

AIDS

Description	Source/Part No.
Camshaft Lubricant (Valspar ZZ613)	Rehiko 25 357 14-S
Dielectric Grease (GE/Novaguard G661)	Rehiko 25 357 11-S
Dielectric Grease	Loctite® 51360
Rehiko Electric Starter Drive Lubricant (Inertia Drive)	Rehiko 52 357 01-S
Rehiko Electric Starter Drive Lubricant (Solenoid Shift)	Rehiko 52 357 02-S
RTV Silicone Sealant Loctite® 5900® Heavy Body in 4 oz. aerosol dispenser. Only oxime-based, oil resistant RTV sealants, such as those listed, are approved for use. Permatex® the Right Stuff® 1 Minute Gasket™ or Loctite® Nos. 5900® or 5910® are recommended for best sealing characteristics.	Rehiko 25 597 07-S Loctite® 5910® Loctite® Ultra Black 598™ Loctite® Ultra Blue 587™ Loctite® Ultra Copper 5920™ Permatex® the Right Stuff® 1 Minute Gasket™
Spline Drive Lubricant	Rehiko 25 357 12-S

Tools and Aids

FLYWHEEL HOLDING TOOL

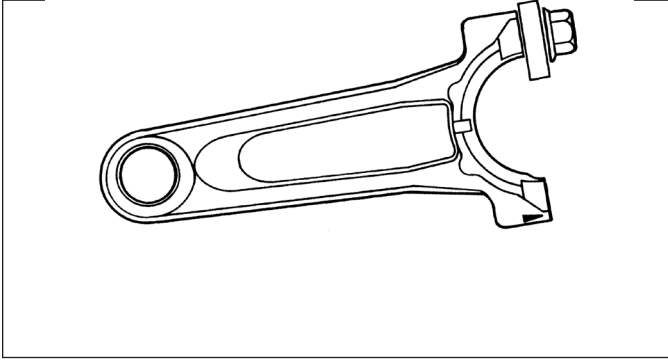

A flywheel holding tool can be made out of an old junk flywheel ring gear and used in place of a strap wrench.

1. Using an abrasive cut-off wheel, cut out a six tooth segment of ring gear as shown.
2. Grind off any burrs or sharp edges.
3. Invert segment and place it between ignition bosses on crankcase so tool teeth engage flywheel ring gear teeth. Bosses will lock tool and flywheel in position for loosening, tightening, or removing with a puller.

ROCKER ARM/CRANKSHAFT TOOL

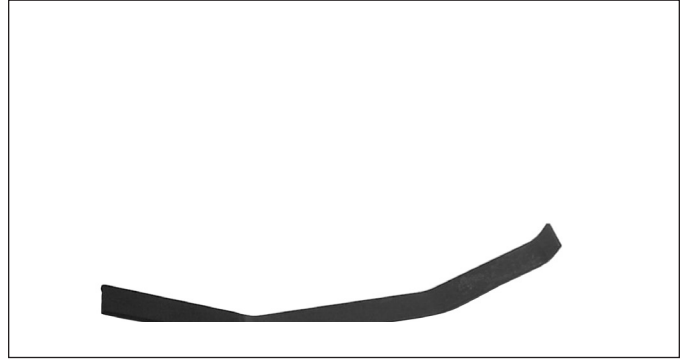

A spanner wrench to lift rocker arms or turn crankshaft may be made out of an old junk connecting rod.

1. Find a used connecting rod from a 10 HP or larger engine. Remove and discard rod cap.
2. Remove studs of a Posi-Lock rod or grind off aligning steps of a Command rod, so joint surface is flat.
3. Find a 1 in. long capscrew with correct thread size to match threads in connecting rod.
4. Use a flat washer with correct I.D. to slip on capscrew and approximately 1 in. O.D. Assemble capscrew and washer to joint surface of rod.

TROUBLESHOOTING GUIDE

When troubles occur, be sure to check simple causes which, at first, may seem too obvious to be considered. For example, a starting problem could be caused by an empty fuel tank.

Some general common causes of engine troubles are listed below and vary by engine specification. Use these to locate causing factors.

Engine Cranks But Will Not Start

- Battery connected backwards.
- Blown fuse.
- Carburetor solenoid malfunction.
- Choke not closing.
- Clogged fuel line or fuel filter.
- Diode in wiring harness failed in open circuit mode.
- DSAI or DSAM malfunction.
- Empty fuel tank.
- Faulty electronic control unit.
- Faulty ignition coil(s).
- Faulty spark plug(s).
- Fuel pump malfunction-vacuum hose clogged or leaking.
- Fuel shut-off valve closed.
- Ignition module(s) faulty or improperly gapped.
- Insufficient voltage to electronic control unit.
- Interlock switch is engaged or faulty.
- Key switch or kill switch in OFF position.
- Low oil level.
- Quality of fuel (dirt, water, stale, mixture).
- SMART-SPARK™ malfunction.
- Spark plug lead(s) disconnected.

Engine Starts But Does Not Keep Running

- Faulty carburetor.
- Faulty cylinder head gasket.
- Faulty or misadjusted choke or throttle controls.
- Fuel pump malfunction-vacuum hose clogged or leaking.
- Intake system leak.
- Loose wires or connections that intermittently ground ignition kill circuit.
- Quality of fuel (dirt, water, stale, mixture).
- Restricted fuel tank cap vent.

Engine Starts Hard

- Clogged fuel line or fuel filter.
- Engine overheated.
- Faulty ACR mechanism.
- Faulty or misadjusted choke or throttle controls.
- Faulty spark plug(s).
- Flywheel key sheared.
- Fuel pump malfunction-vacuum hose clogged or leaking.
- Interlock switch is engaged or faulty.
- Loose wires or connections that intermittently ground ignition kill circuit.
- Low compression.
- Quality of fuel (dirt, water, stale, mixture).
- Weak spark.

Engine Will Not Crank

- Battery is discharged.
- Faulty electric starter or solenoid.
- Faulty key switch or ignition switch.
- Interlock switch is engaged or faulty.
- Loose wires or connections that intermittently ground ignition kill circuit.
- Pawls not engaging in drive cup.
- Seized internal engine components.

Engine Runs But Misses

- Carburetor adjusted incorrectly.
- Engine overheated.
- Faulty spark plug(s).
- Ignition module(s) faulty or improperly gapped.
- Incorrect crankshaft position sensor air gap.
- Interlock switch is engaged or faulty.
- Loose wires or connections that intermittently ground ignition kill circuit.
- Quality of fuel (dirt, water, stale, mixture).
- Spark plug lead(s) disconnected.
- Spark plug lead boot loose on plug.
- Spark plug lead loose.

Engine Will Not Idle

- Engine overheated.
- Faulty spark plug(s).
- Idle fuel adjusting needle(s) improperly set.
- Idle speed adjusting screw improperly set.
- Inadequate fuel supply.
- Low compression.
- Quality of fuel (dirt, water, stale, mixture).
- Restricted fuel tank cap vent.

Engine Overheats

- Cooling fan broken.
- Excessive engine load.
- Fan belt failed/off.
- Faulty carburetor.
- High crankcase oil level.
- Lean fuel mixture.
- Low cooling system fluid level.
- Low crankcase oil level.
- Radiator, and/or cooling system components clogged, restricted, or leaking.
- Water pump belt failed/broken.
- Water pump malfunction.

Engine Knocks

- Excessive engine load.
- Hydraulic lifter malfunction.
- Incorrect oil viscosity/type.
- Internal wear or damage.
- Low crankcase oil level.
- Quality of fuel (dirt, water, stale, mixture).

Troubleshooting

Engine Loses Power

- Dirty air cleaner element.
- Engine overheated.
- Excessive engine load.
- Restricted exhaust.
- Faulty spark plug(s).
- High crankcase oil level.
- Incorrect governor setting.
- Low battery.
- Low compression.
- Low crankcase oil level.
- Quality of fuel (dirt, water, stale, mixture).

Engine Uses Excessive Amount of Oil

- Loose or improperly torqued fasteners.
- Blown head gasket/overheated.
- Breather reed broken.
- Clogged, broken, or inoperative crankcase breather.
- Crankcase overfilled.
- Incorrect oil viscosity/type.
- Worn cylinder bore.
- Worn or broken piston rings.
- Worn valve stems/valve guides.

Oil Leaks from Oil Seals, Gaskets

- Breather reed broken.
- Clogged, broken, or inoperative crankcase breather.
- Loose or improperly torqued fasteners.
- Piston blow by, or leaky valves.
- Restricted exhaust.

EXTERNAL ENGINE INSPECTION



NOTE: It is good practice to drain oil at a location away from workbench. Be sure to allow ample time for complete drainage.

Before cleaning or disassembling engine, make a thorough inspection of its external appearance and condition. This inspection can give clues to what might be found inside engines (and cause) when it is disassembled.

- Check for buildup of dirt and debris on crankcase, cooling fins, grass screen, and other external surfaces. Dirt or debris on these areas can cause overheating.
- Check for obvious fuel and oil leaks, and damaged components. Excessive oil leakage can indicate a clogged or inoperative breather, worn or damaged seals or gaskets, or loose fasteners.
- Check air cleaner cover and base for damage or indications of improper fit and seal.
- Check air cleaner element. Look for holes, tears, cracked or damaged sealing surfaces, or other damage that could allow unfiltered air into engine. A dirty or clogged element could indicate insufficient or improper maintenance.
- Check carburetor throat for dirt. Dirt in throat is further indication that air cleaner was not functioning properly.
- Check if oil level is within operating range on dipstick. If it is above, sniff for gasoline odor.
- Check condition of oil. Drain oil into a container; it should flow freely. Check for metal chips and other foreign particles.

Sludge is a natural by-product of combustion; a small accumulation is normal. Excessive sludge formation could indicate over rich fuel settings, weak ignition, overextended oil change interval or wrong weight or type of oil was used.

CLEANING ENGINE

	 WARNING
	Cleaning Solvents can cause severe injury or death. Use only in well ventilated areas away from ignition sources.
Carburetor cleaners and solvents are extremely flammable. Follow cleaner manufacturer's warnings and instructions on its proper and safe use. Never use gasoline as a cleaning agent.	

After inspecting external condition of engine, clean engine thoroughly before disassembly. Clean individual components as engine is disassembled. Only clean parts can be accurately inspected and gauged for wear or damage. There are many commercially available cleaners that will quickly remove grease, oil, and grime from engine parts. When such a cleaner is used, follow manufacturer's instructions and safety precautions carefully.

Make sure all traces of cleaner are removed before engine is reassembled and placed into operation. Even small amounts of these cleaners can quickly break down lubricating properties of engine oil.

CRANKCASE VACUUM TEST

	⚠ WARNING
	Carbon Monoxide can cause severe nausea, fainting or death. Avoid inhaling exhaust fumes. Never run engine indoors or in enclosed spaces.
Engine exhaust gases contain poisonous carbon monoxide. Carbon monoxide is odorless, colorless, and can cause death if inhaled.	

	⚠ WARNING
	Rotating Parts can cause severe injury. Stay away while engine is in operation.
Keep hands, feet, hair, and clothing away from all moving parts to prevent injury. Never operate engine with covers, shrouds, or guards removed.	

A partial vacuum should be present in crankcase when engine is operating. Pressure in crankcase (normally caused by a clogged or improperly assembled breather) can cause oil to be forced out at oil seals, gaskets, or other available spots.

Crankcase vacuum is best measured with either a water manometer or a vacuum gauge. Complete instructions are provided in kits.

To test crankcase vacuum with manometer:

1. Insert rubber stopper into oil fill hole. Be sure pinch clamp is installed on hose and use tapered adapters to connect hose between stopper and one manometer tube. Leave other tube open to atmosphere. Check that water level in manometer is at 0 line. Make sure pinch clamp is closed.
2. Start engine and run no-load high speed.
3. Open clamp and note water level in tube.
Level in engine side should be a minimum of 10.2 cm (4 in.) above level in open side.
If level in engine side is less than specified (low/no vacuum), or level in engine side is lower than level in open side (pressure), check for conditions in table below.
4. Close pinch clamp before stopping engine.

To test crankcase vacuum with vacuum/pressure gauge:

1. Remove dipstick or oil fill plug/cap.
2. Install adapter into oil fill//dipstick tube opening, upside down over end of a small diameter dipstick tube, or directly into engine if a tube is not used. Insert barbed gauge fitting into hole in stopper.
3. Run engine and observe gauge reading.
Analog tester—needle movement to left of 0 is a vacuum, and movement to right indicates a pressure.
Digital tester—depress test button on top of tester.
Crankcase vacuum should be a minimum of 10.2 cm (4 in.) of water. If reading is below specification, or if pressure is present, check table below for possible causes and conclusions.

Condition	Conclusion
Crankcase breather clogged or inoperative.	NOTE: If breather is integral part of valve cover and cannot be serviced separately, replace valve cover and recheck pressure. Disassemble breather, clean parts thoroughly, check sealing surfaces for flatness, reassemble, and recheck pressure.
Seals and/or gaskets leaking. Loose or improperly torque fasteners.	Replace all worn or damaged seals and gaskets. Make sure all fasteners are tightened securely. Use appropriate torque valves and sequences when necessary.
Piston blow by or leaky valves (confirm by inspecting components).	Recondition piston, rings, cylinder bore, valves and valves guides.
Restricted exhaust.	Check exhaust screen/spark arrestor (if equipped). Clean or replace as needed. Repair or replace any other damaged/restricted muffler or exhaust system parts.

Troubleshooting

COMPRESSION TEST

For Command Twins:

A compression test is best performed on a warm engine. Clean any dirt or debris away from base of spark plug(s) before removing them. Be sure choke is off, and throttle is wide open during test. Compression should be at least 160 psi and should not vary more than 15% between cylinders.

All other models:

These engines are equipped with an automatic compression release (ACR) mechanism. It is difficult to obtain an accurate compression reading because of ACR mechanism. As an alternative, use cylinder leakdown test described below.

CYLINDER LEAKDOWN TEST

A cylinder leakdown test can be a valuable alternative to a compression test. By pressurizing combustion chamber from an external air source you can determine if valves or rings are leaking, and how badly.

Cylinder leakdown tester is a relatively simple, inexpensive leakdown tester for small engines. This tester includes a quick-connect for attaching adapter hose and a holding tool.

1. Run engine for 3-5 minutes to warm it up.
2. Remove spark plug(s) and air filter from engine.
3. Rotate crankshaft until piston (of cylinder being tested) is at top dead center (TDC) of compression stroke. Hold engine in this position while testing. Holding tool supplied with tester can be used if PTO end of crankshaft is accessible. Lock holding tool onto crankshaft. Install a 3/8 in. breaker bar into hole/slot of holding tool, so it is perpendicular to both holding tool and crankshaft PTO.

If flywheel end is more accessible, use a breaker bar and socket on flywheel nut/screw to hold it in position. An assistant may be needed to hold breaker bar during testing. If engine is mounted in a piece of equipment, it may be possible to hold it by clamping or wedging a driven component. Just be certain that engine cannot rotate off of TDC in either direction.

4. Install adapter into spark plug hole, but do not attach it to tester at this time.
5. Turn regulator knob completely counterclockwise.
6. Connect an air source of at least 50 psi to tester.
7. Turn regulator knob clockwise (increase direction) until gauge needle is in yellow set area at low end of scale.
8. Connect tester quick-connect to adapter hose. While firmly holding engine at TDC, gradually open tester valve. Note gauge reading and listen for escaping air at combustion air intake, exhaust outlet, and crankcase breather.

Condition	Conclusion
Air escaping from crankcase breather.	Ring or cylinder worn.
Air escaping from exhaust system.	Defective exhaust valve/improper seating.
Air escaping from intake.	Defective intake valve/improper seating.
Gauge reading in low (green) zone.	Piston rings and cylinder in good condition.
Gauge reading in moderate (yellow) zone.	Engine is still usable, but there is some wear present. Customer should start planning for overhaul or replacement.
Gauge reading in high (red) zone.	Rings and/or cylinder have considerable wear. Engine should be reconditioned or replaced.

AIR CLEANER

These systems are CARB/EPA certified and components should not be altered or modified in any way.

Dual-Element Air Cleaner Components

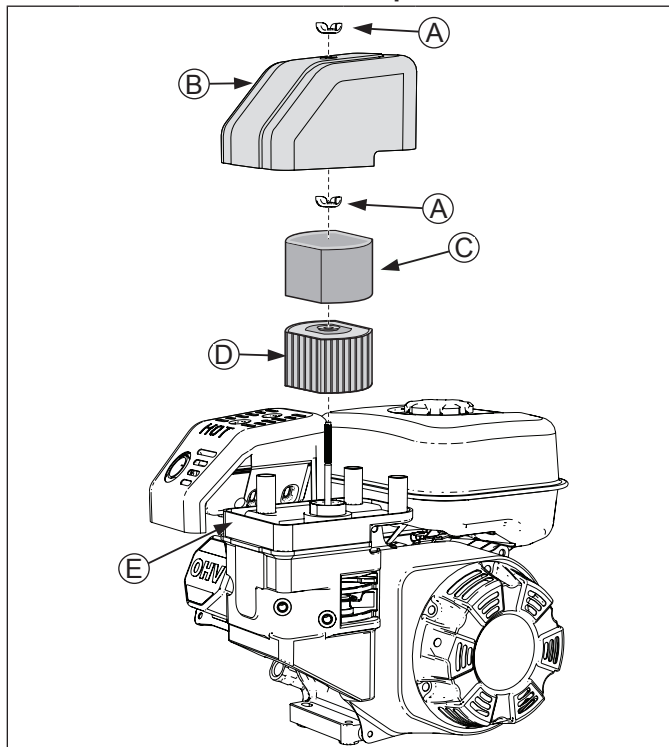

A	Wing Nut	B	Air Cleaner Cover
C	Precleaner	D	Paper Element
E	Air Cleaner Base		

Low-Profile Air Cleaner Components

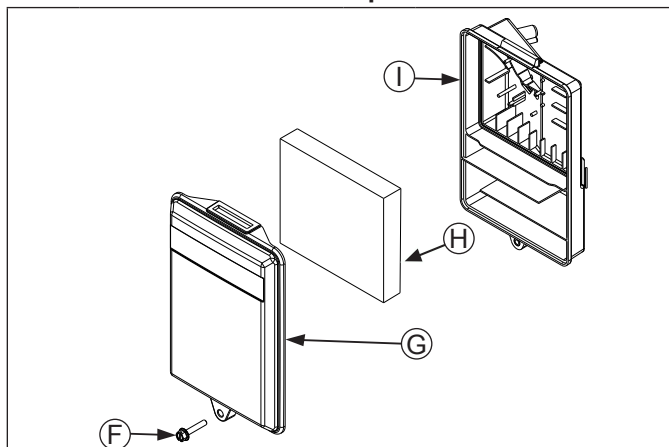

F	Air Cleaner Base	G	Foam Element
H	Air Cleaner Cover	I	Screw

NOTE: Operating engine with loose or damaged air cleaner components could cause premature wear and failure. Replace all bent or damaged components.

NOTE: Paper element cannot be blown out with compressed air.

Dual-Element

Remove wing nut and air cleaner cover.

Precleaner

1. Remove precleaner from paper element.
2. Replace or wash precleaner in warm water with detergent. Rinse and allow to air dry.
3. Reinstall precleaner over paper element.

Paper Element

1. Remove wing nut (if equipped) and paper element with precleaner.
2. Separate precleaner from element; service precleaner and replace element.
3. Reinstall precleaner over paper element; secure with wing nut (if equipped).

Reinstall air cleaner cover and secure with wing nut.

Low-Profile

1. Remove screw and air cleaner cover.
2. Remove foam element from base.
3. Wash foam element in warm water with detergent. Rinse and allow to air dry.
4. Lightly oil foam element with new engine oil; squeeze out excess oil.
5. Reinstall foam element into base.
6. Reinstall cover and secure with screw.

BREATHER TUBE

Make sure both ends of breather tube are properly connected.

AIR COOLING

	WARNING
	<p>Hot Parts can cause severe burns. Do not touch engine while operating or just after stopping.</p>
<p>Never operate engine with heat shields or guards removed.</p>	

Proper cooling is essential. To prevent over heating, clean screens, cooling fins, and other external surfaces of engine. Avoid spraying water at wiring harness or any electrical components. Refer to Maintenance Schedule.

Fuel System

Typical carbureted fuel system and related components include:

- Fuel tank.
- Fuel lines.
- In-line fuel filter.
- Fuel tank filter.
- Carburetor.
- Fuel strainer screen in carburetor.

Fuel tank outlet is located above carburetor inlet, allowing gravity to feed fuel through in-line filter and fuel line to carburetor.

Fuel then enters carburetor through a fuel shut-off valve and a fine screen/sediment bowl, and then to carburetor float bowl. Fuel is drawn into carburetor body and is mixed with air. This fuel-air mixture is then burned in engine combustion chamber.

FUEL RECOMMENDATIONS

Refer to Maintenance.

FUEL LINE

Low permeation fuel line must be installed on carbureted Rehlko engines to maintain EPA and CARB regulatory compliance.

FUEL FILTER

Fuel Tank Filter

A serviceable fuel tank filter is located under fuel tank cap, in filler neck.

Daily or as required clean filter of any accumulation as follows:

1. Remove fuel tank cap and filter.
2. Clean filter with solvent, replace if damaged.
3. Wipe filter and insert it.
4. Tighten fuel tank cap securely.

FUEL SYSTEM TESTS

When engine starts hard or turns over but will not start, fuel system might be causing problems. Test fuel system by performing following test.

1. Check for fuel in combustion chamber.
 - a. Disconnect and ground spark plug lead.
 - b. Close choke on carburetor.
 - c. Crank engine several times.
 - d. Remove spark plug and check for fuel at tip.
2. Check for fuel flow from tank to carburetor.
 - a. Remove fuel line from inlet fitting of carburetor.
 - b. Use an approved fuel container to catch fuel, and hold line below bottom of tank to observe fuel flow.
3. Check operation of fuel shut-off valve.
 - a. Remove fuel sediment bowl under inlet fitting of carburetor.
 - b. Turn fuel shut-off valve ON and OFF and observe operation.

Fuel Shut-Off

	WARNING
	<p>Explosive Fuel can cause fires and severe burns.</p> <p>Do not fill fuel tank while engine is hot or running.</p>
<p>Gasoline is extremely flammable and its vapors can explode if ignited. Store gasoline only in approved containers, in well ventilated, unoccupied buildings, away from sparks or flames. Spilled fuel could ignite if it comes in contact with hot parts or sparks from ignition. Never use gasoline as a cleaning agent.</p>	

Engines are equipped with a fuel shut-off located at carburetor. It controls fuel flow from tank to carburetor.

1. Stop engine.
2. Turn fuel shut-off lever to OFF position.
3. Remove fuel shut-off cup.
4. Clean fuel shut-off cup with solvent and wipe dry.
5. Inspect for worn or damaged O-ring; replace as necessary.
6. Place O-ring on fuel shut-off cup. Install fuel shut-off cup and O-ring; rotate until finger tight. Turn with a wrench 1/2 to 3/4 full turn.
7. Turn fuel shut-off lever to ON position and check for leaks. If fuel shut-off cup leaks, repeat steps 5 and 6.
8. Tighten fuel tank cap securely.

Condition	Conclusion
Fuel at tip of spark plug.	Fuel is reaching combustion chamber.
No fuel at tip of spark plug.	Check fuel flow from fuel tank (step 2).
Fuel flows from fuel line.	Check operation of fuel shut-off valve (step 3).
No fuel flow from fuel line.	Check fuel tank vent, in-line filter threaded into tank, and fuel line. Correct any observed problem and reconnect line.
Fuel flows from valve.	Check for dirt and water in sediment bowl and screen. Clean bowl and screen as needed. Check for faulty carburetor, refer to Carburetor.
No fuel flows from valve.	Check for a restriction in fuel shut-off valve or inlet elbow.

CARBURETOR

	▲ WARNING	Gasoline is extremely flammable and its vapors can explode if ignited. Store gasoline only in approved containers, in well ventilated, unoccupied buildings, away from sparks or flames. Spilled fuel could ignite if it comes in contact with hot parts or sparks from ignition. Never use gasoline as a cleaning agent.
	Explosive Fuel can cause fires and severe burns. Do not fill fuel tank while engine is hot or running.	

Typical One-Barrel Carburetor Components

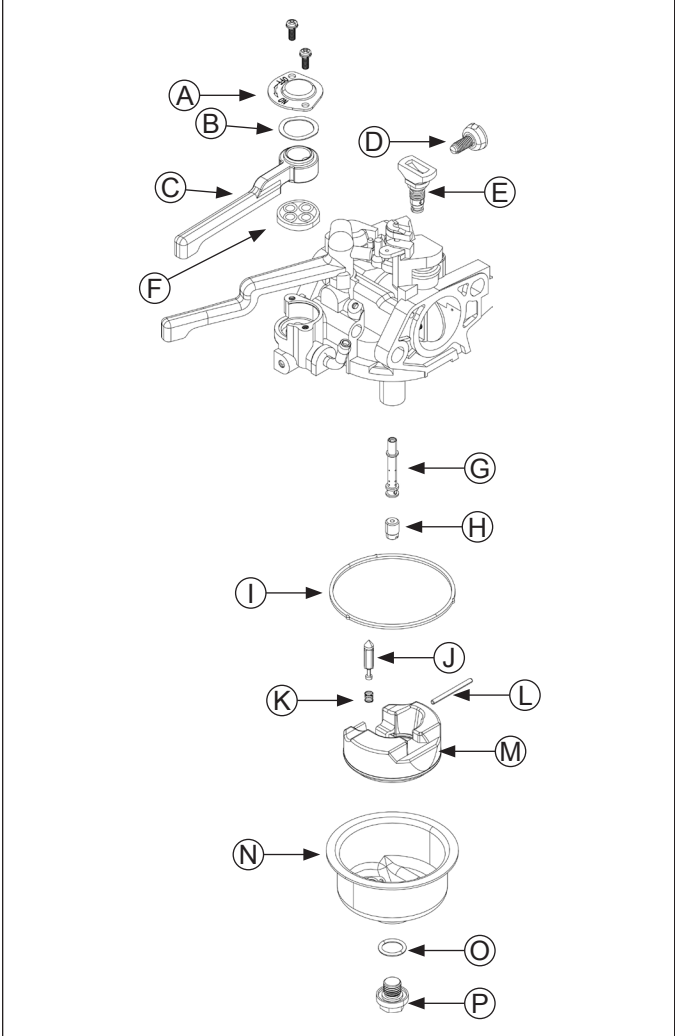

A	Fuel Shut-Off	B	Wave Washer
C	Fuel Shut-Off Valve	D	Low Idle Speed Adjusting Screw
E	Idle Jet	F	Fuel Shut-Off Gasket
G	Main Nozzle Tube	H	Main Jet
I	Bowl Gasket	J	Fuel Inlet Needle
K	Spring	L	Hinge Pin
M	Float	N	Fuel Bowl
O	Bowl Retaining Screw Gasket	P	Bowl Retaining Screw

These engines are equipped with a fixed main jet carburetor. Carburetor is designed to deliver correct fuel-to-air mixture to engine under all operating conditions. Idle mixture is set at factory and cannot be adjusted.

Troubleshooting Checklist

- When engine starts hard, runs rough, or stalls at low idle speed, check these areas before adjusting or disassembling carburetor.
1. Make sure fuel tank is filled with clean, fresh gasoline.
 2. Make sure fuel tank cap vent is not blocked and is operating properly.
 3. Make sure fuel is reaching carburetor. This includes checking fuel shut-off valve, fuel tank filter screen, in-line fuel filter, fuel lines and fuel pump for restrictions or faulty components as necessary.
 4. Make sure air cleaner base and carburetor are securely fastened to engine using gaskets in good condition.
 5. Make sure air cleaner element (including pre-cleaner if equipped) is clean and all air cleaner components are fastened securely.
 6. Make sure ignition system, governor system, exhaust system, and throttle and choke controls are operating properly.

Fuel System

Troubleshooting-Carburetor Related Causes

Condition	Possible Cause	Conclusion
Engine starts hard, runs rough, or stalls at idle speed.	Low idle fuel mixture (some models)/ speed improperly adjusted.	Adjust idle speed screw or clean carburetor.
Engine runs rich (indicated by black, sooty exhaust smoke, misfiring, loss of speed and power, governor hunting, or excessive throttle opening).	Clogged air cleaner.	Clean or replace air cleaner.
	Choke partially closed during operation.	Check choke lever/linkage to ensure choke is operating properly.
	Dirt under fuel inlet needle.	Remove needle; clean needle and seat and blow with compressed air.
	Bowl vent or air bleeds plugged.	Clean vent, ports, and air bleeds. Blow out all passages with compressed air.
	Leaky, cracked, or damaged float.	Submerge float to check for leaks.
Engine runs lean (indicated by misfiring, loss of speed and power, governor hunting, or excessive throttle opening).	Intake air leak.	Check if carburetor is loose or one of intake gaskets is leaking.
	Idle holes plugged; dirt in fuel delivery channels.	Clean main fuel jet and all passages; blow out with compressed air.
Fuel leaks from carburetor.	Float damaged.	Submerge float to check for leaks. Replace float.
	Dirt under fuel inlet needle.	Remove needle; clean needle and seat and blow with compressed air.
	Bowl vents plugged.	Blow out with compressed air.
	Carburetor bowl gasket leaks.	Replace gasket.

Carburetor Circuits

Float

Fuel level in bowl is maintained by float and fuel inlet needle. Buoyant force of float stops fuel flow when engine is at rest. When fuel is being consumed, float will drop and fuel pressure will push inlet needle away from seat, allowing more fuel to enter bowl. When demand ceases, buoyant force of float will again overcome fuel pressure, rising to predetermined setting and stop flow.

Slow and Mid-Range

At low speeds engine operates only on slow circuit. As a metered amount of air is drawn through slow air bleed jets, fuel is drawn through main jet and further metered through slow jet. Air and fuel are mixed in body of slow jet and exit to idle progression (transfer port) chamber. From idle progression chamber, air fuel mixture is metered through idle port passage. At low idle air/fuel mixture is controlled by setting of idle fuel adjusting screws. This mixture is then mixed with main body of air and delivered to engine. As throttle plate opening increases, greater amounts of air/fuel mixture are drawn in through fixed and metered idle progression holes. As throttle plate opens further, vacuum signal becomes great enough at venturi so main circuit begins to work.

Main (high-speed)

At high speeds/loads engine operates on main circuit. As a metered amount of air is drawn through air jet, fuel is drawn through main jet. Air and fuel are mixed in main nozzles then enters main body of airflow where further mixing of fuel and air occurs. This mixture is then delivered to combustion chamber. Carburetor has a fixed main circuit; no adjustment is possible.

Carburetor Adjustments

NOTE: Carburetor adjustments should be made only after engine has warmed up.



Carburetor is designed to deliver correct fuel-to-air mixture to engine under all operating conditions. Main fuel jet is calibrated at factory and is not adjustable. Idle fuel adjusting needles are also set at factory and are not adjustable.

Low Idle Speed (RPM) Adjustment

NOTE: Actual low idle speed depends on application. Refer to equipment manufacturer's recommendations. Low idle speed for basic engines is 1800 RPM.

1. Place throttle control into idle or slow position. Turn low idle speed adjusting screw in or out to obtain allow idle speed of 1800 RPM (\pm 75 RPM).

Carburetor Servicing

  	⚠ WARNING
	<p>Accidental Starts can cause severe injury or death.</p> <p>Disconnect and ground spark plug lead(s) before servicing.</p>
<p>Before working on engine or equipment, disable engine as follows: 1) Disconnect spark plug lead(s). 2) Disconnect negative (-) battery cable from battery.</p>	

NOTE: Main and slow jets are fixed and size specific and can be removed if required. Fixed jets for high altitudes are available.

- Inspect carburetor body for cracks, holes, and other wear or damage.
 - Inspect float for cracks, holes, and missing or damaged float tabs. Check float hinge and shaft for wear or damage.
 - Inspect fuel inlet needle and seat for wear or damage.
1. Perform removal procedures for appropriate air cleaner and carburetor outlined in Disassembly.
 2. Clean exterior surfaces of dirt or foreign material before disassembling carburetor. Remove bowl retaining screws, and carefully separate fuel bowl from carburetor. Do not damage fuel bowl O-rings. Transfer any remaining fuel into an approved container. Save all parts. Fuel can also be drained prior to bowl removal by loosening/removing bowl drain screw.
 3. Remove float pin and inlet needle. Seat for inlet needle is not serviceable and should not be removed.
 4. Clean carburetor bowl and inlet seat areas as required.
 5. Carefully remove main jet from carburetor. After main jet is removed, main nozzles can be removed through bottom of main towers. Note orientation/direction of nozzles. End with 2 raised shoulders should be out/down adjacent to main jets.
 6. Save parts for cleaning and reuse unless a jet kit is also being installed. Clean slow jets using compressed air or carburetor cleaner, do not use wire.

NOTE: There are 2 O-rings on body of idle jet.

Carburetor is now disassembled for appropriate cleaning and installation of parts in overhaul kit. See instructions provided with repair kits for more detailed information.

High Altitude Operation

If this engine is operated at an altitude of 4000 ft. (1219 meters) or above, a high altitude carburetor kit is required. To obtain high altitude carburetor kit information or to find a Rehlko authorized dealer, visit Engines.rehlko.com or call 1-800-544-2444 (U.S. and Canada).

This engine should be operated in its original configuration below 4000 ft. (1219 meters).

Operating this engine with the wrong engine configuration at a given altitude may increase its emissions, decrease fuel efficiency and performance, and result in damage to the engine.

Governor System

GOVERNOR

Governor Components

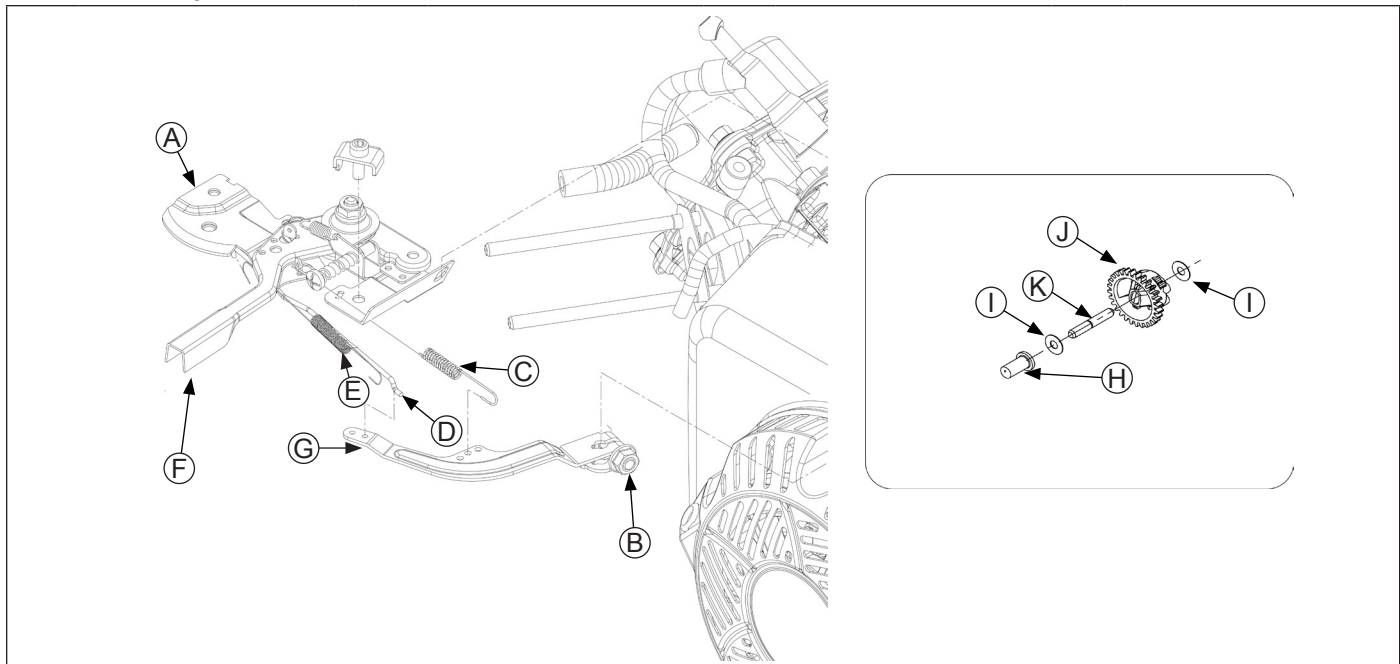

A	Control Assembly	B	Nut	C	Governor Spring	D	Throttle Link
E	Dampening Spring	F	Throttle Control Lever	G	Governor Lever	H	Cup
I	Washer	J	Governor Gear	K	Governor Gear Shaft		

Governed speed setting is determined by position of throttle control. It can be variable or constant, depending on engine application.

Governor is designed to hold engine speed constant under changing load conditions. Most engines are equipped with a centrifugal flyweight mechanical governor. Governor gear/flyweight mechanism of mechanical governor is mounted inside crankcase and is driven off gear on crankshaft.

This governor design works as follows:

- Centrifugal force acting on rotating governor gear assembly causes flyweights to move outward as speed increases. Governor spring tension moves them inward as speed decreases.
- As flyweights move outward, they cause regulating pin to move outward.
- Regulating pin contacts tab on cross shaft causing shaft to rotate.
- One end of cross shaft protrudes through crankcase. Rotating action of cross shaft is transmitted to throttle lever of carburetor through external throttle linkage.
- When engine is at rest, and throttle is in fast position, tension of governor spring holds throttle plate open. When engine is operating, governor gear assembly is rotating. Force applied by regulating pin against cross shaft tends to close throttle plate. Governor spring tension and force applied by regulating pin balance each other during operation, to maintain engine speed.

- When load is applied and engine speed and governor gear speed decreases, governor spring tension moves governor arm to open throttle plate wider. This allows more fuel into engine, increasing engine speed. As speed reaches governed setting, governor spring tension and force applied by regulating pin will again offset each other to hold a steady engine speed.

Governor Adjustments

Initial Adjustment Procedure

NOTE: Make sure carburetor is mounted and secured in place when adjustment is being made/checked.

Make this initial adjustment whenever governor lever is loosened or removed from cross shaft. To ensure proper setting, make sure throttle linkage is connected to governor lever and to carburetor throttle lever.

Adjust as follows:

1. Close fuel shut-off valve.
2. Remove air cleaner outer cover. Then either reposition fuel tank to access governor shaft and lever joint, or disconnect fuel line and remove tank from engine.
3. Loosen governor lever mounting nut.
4. Move governor lever clockwise until it stops.
5. Rotate governor shaft clockwise until it stops.
6. Hold both in this position and torque governor lever nut to 10 N·m (88.5 in. lb.).

These engines use a splash lubrication system, supplying necessary lubrication to crankshaft, camshaft, connecting rod and valve train components.

Lubrication Components

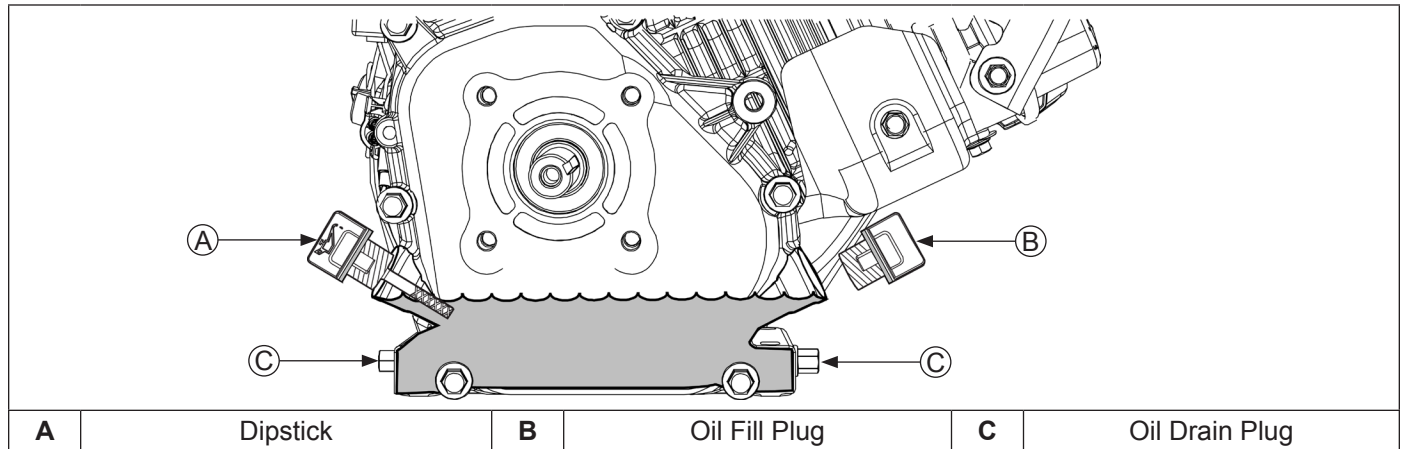

OIL RECOMMENDATIONS

Refer to Maintenance.

CHECK OIL LEVEL

NOTE: To prevent extensive engine wear or damage, never run engine with oil level below or above operating range indicator on dipstick.

Ensure engine is cool. Clean oil fill/dipstick areas of any debris.

1. Remove dipstick; wipe oil off.
2. Reinsert dipstick into tube; rest on oil fill neck; turn counterclockwise until cap drops down to lowest point of thread leads; do not thread cap onto tube.
 - a. Remove dipstick; check oil level. Level should be at top of indicator on dipstick.
 - or
 - b. Remove oil fill plug. Level should be up to point of overflowing filler neck.
3. If oil is low, add oil up to point of overflowing filler neck.
4. Reinstall dipstick or oil fill plug and tighten securely.

CHANGE OIL

Change oil while engine is warm.

1. Clean area around oil fill plug/dipstick and drain plug.
2. Remove drain plug and oil fill plug/dipstick. Drain oil completely.
3. Reinstall drain plug. Torque 18 N·m (13 ft. lb.).
4. Fill crankcase with new oil, up to point of overflowing filler neck.
5. Reinstall oil fill plug/dipstick and tighten securely.
6. Dispose of used oil in accordance with local ordinances.

OIL SENTRY™ (if equipped)

This switch is designed to prevent engine from starting in a low oil or no oil condition. Oil Sentry™ may not shut down a running engine before damage occurs. In some applications this switch may activate a warning signal. Read your equipment manuals for more information. For testing procedures refer to Electronic Ignition Systems and Oil Sentry™ Tests.

Electrical System

SPARK PLUGS

	⚠ CAUTION
	Electrical Shock can cause injury. Do not touch wires while engine is running.

Spark Plug Component and Details

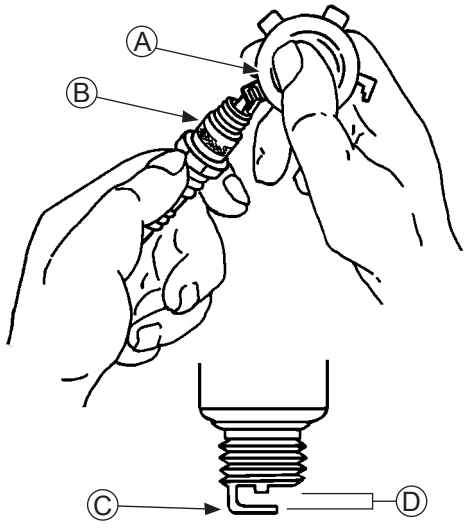

A	Wire Gauge	B	Spark Plug
C	Ground Electrode	D	Gap

NOTE: Do not clean spark plug in a machine using abrasive grit. Some grit could remain in spark plug and enter engine causing extensive wear and damage.

Engine misfire or starting problems are often caused by a spark plug that has improper gap or is in poor condition.

Engine is equipped with following spark plugs:

Gap	0.76 mm (0.030 in.)
Thread Size	14 mm
Reach	19.1 mm (3/4 in.)
Hex Size	15.9 mm (5/8 in.)

Refer to Maintenance for Repairs/Service Parts.

Service

Clean out spark plug recess. Remove plug and replace.

1. Check gap using wire feeler gauge. Adjust gap to 0.76 mm (0.030 in.).
2. Install plug into cylinder head.
3. Torque plug to 27 N·m (20 ft. lb.).

Inspection

Inspect each spark plug as it is removed from cylinder head. Deposits on tip are an indication of general condition of piston rings, valves, and carburetor.

Normal and fouled plugs are shown in following photos:

Normal



Plug taken from an engine operating under normal conditions will have light tan or gray colored deposits. If center electrode is not worn, plug can be set to proper gap and reused.

Worn



On a worn plug, center electrode will be rounded and gap will be greater than specified gap. Replace a worn spark plug immediately.

Wet Fouled



A wet plug is caused by excess fuel or oil in combustion chamber. Excess fuel could be caused by a restricted air cleaner, a carburetor problem, or operating engine with too much choke. Oil in combustion chamber is usually caused by a restricted air cleaner, a breather problem, worn piston rings, or valve guides.

Carbon Fouled



Soft, sooty, black deposits indicate incomplete combustion caused by a restricted air cleaner, over rich carburetion, weak ignition, or poor compression.

Overheated



Chalky, white deposits indicate very high combustion temperatures. This condition is usually accompanied by excessive gap erosion. Lean carburetor settings, an intake air leak, or incorrect spark timing are normal causes for high combustion temperatures.

BATTERY

A 12 volt battery (not furnished) with a minimum current rating of 230 cold cranking amps/18 amp hours should be sufficient for cranking most electric start engine models. Actual cold cranking requirement depends on engine size, application and starting temperatures. Cranking requirements increase as temperatures decrease and battery capacity shrinks. Refer to equipment's operating instructions for specific battery requirements.

If battery charge is insufficient to turn over engine, recharge battery.

Battery Maintenance

Regular maintenance is necessary to prolong battery life.

Battery Test

To test battery, follow manufacturer's instructions.

ELECTRONIC IGNITION SYSTEM

Inductive Discharge Ignition System Components

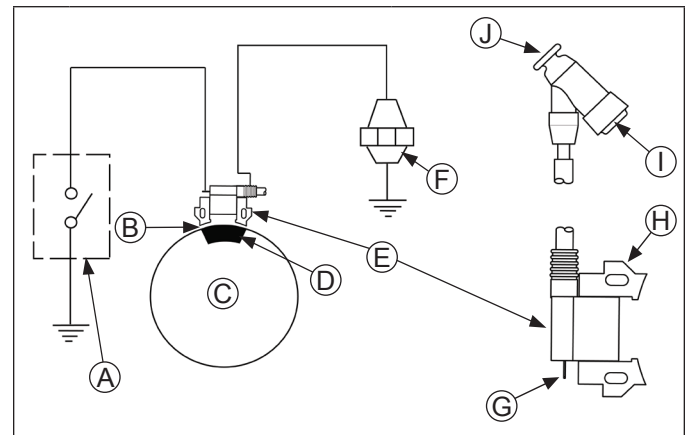

A	Kill Switch/Off Position of Key Switch	B	Air Gap 0.254 mm (0.010 in.)
C	Flywheel	D	Magnet
E	Ignition Module	F	Spark Plug
G	Kill Terminal	H	Lamination
I	Spark Plug Terminal	J	Spark Plug Boot

These engines are equipped with a dependable magneto breakerless ignition. In such a system, electrical energy is generated by cutting of magnetic flux lines generated from ignition magnet on engine flywheel via prescribed air gap as it passes ignition module. This energy is transferred through ignition module laminations and is then converted in module electronics and stored in module primary coil, as a current. Stored energy is transferred at correct moment by triggering a semiconductor switch inside module. Electrical break by switch initiates energy transfer by causing collapse of magnetic field at coil primary. This includes a voltage at coil primary that is amplified via transformer action at coil secondary. Amplitude of voltage at coil secondary is sufficient to jump gap at spark plug, igniting fuel air mixture in gap and initiating combustion. Note that by design, these modules only will provide proper function if mounted in correct orientation.

This ignition system is designed to be trouble free for life of engine. Other than periodically checking/replacing spark plugs, no maintenance or timing adjustments are necessary or possible. Mechanical systems do occasionally fail or break down. Refer to Troubleshooting to determine root of a reported problem.

Reported ignition problems are most often due to poor connections. Before beginning test procedure, check all external wiring. Be certain all ignition-related wires are connected, including spark plug leads. Be certain all terminal connections fit snugly. Make sure ignition switch is in run position.

Electrical System

Electronic Ignition Systems and Oil Sentry™ Tests

1. Disconnect cap from spark plug and attach it to terminal end of spark tester. Attach tester spring clip to a good ground, not to spark plug. Turn ignition/key switch ON and crank engine while observing firing tip of tester.

Condition	Conclusion
Tester is firing.	Ignition system is good. Install a new spark plug and try to start engine. If it still will not start, check other possible causes (fuel, compression, etc.).
Tester doesn't fire.	Go to step 2.

2. Trace yellow lead wire from Oil Sentry™ control module to Oil Sentry™ float switch. Disconnect bullet connector where it joins lead from Oil Sentry™ float switch (yellow lead wire). Repeat spark test.

Condition	Conclusion
Spark is now present.	Control module or float switch is faulty. Test control module (step 3) and float switch (step 4).
Still no spark.	Test ignition module (step 5).

3. Connect a jumper lead from yellow lead terminal to a bare spot on crankcase (ground). Turn ignition switch ON, crank engine, and observe red LED indicator lamp.

Condition	Conclusion
Indicator lamp was not flashing.	Trace black lead from ignition switch. Separate bullet connector where switch lead joins double red harness lead. Crank engine, again observing red LED indicator lamp.
Indicator lamp flashes during cranking.	Control module is functioning, proceed to step 5. If lamp was not flashing initially but did flash in step 3, control module is good, but ignition switch is probably faulty. Test float switch (step 4) and ignition switch (step 6).

4. Set an ohmmeter to Rx1 scale and zero meter. Connect one ohmmeter lead to Oil Sentry™ float switch lead (yellow with green sleeve) and touch other lead to a bare spot on crankcase (ground). Drain oil from crankcase and repeat test.

With oil at proper level, no continuity should have been indicated. After oil was drained, continuity should have been indicated.

Condition	Conclusion
No continuity indicated.	Remove closure plate from engine and remove float switch for further testing (steps 4a and 4b).

- a. If continuity was indicated with and without oil above, check if insulation has been scraped off float switch lead.

Condition	Conclusion
Lead wire is bare.	Allow it to short, repair with electrical tape, or replace float switch.

- b. With float switch removed, connect one ohmmeter lead to float switch lead terminal and connect other lead to mounting bracket. Test resistance with switch in normal position and inverted. Repeat test 2 or 3 times in each direction.

Condition	Conclusion
Switch continuity should be as indicated.	If not, replace it.

5. Set an ohmmeter to Rx1K or Rx10K scale and zero. Connect one ohmmeter lead to kill lead (black/white) terminal and connect other lead into spark plug cap.
 - a. Remove cap from spark plug lead and test resistance of cap alone.
 - b. If resistances are other than specified, remove blower housing and remove ignition module. With kill lead and spark plug cap removed, test resistance from small spade terminal to core of spark plug lead wire. If resistance is not in this range, replace module.

Resistance Chart	
Ignition Module	13.5-18.0 K ohms
Cap	4-6 K ohms
Spade Terminal to Spark Plug Lead Wire	9.5-12.9 K ohms

6. Set an ohmmeter to Rx1 scale and zero meter. Test ignition/key switch as follows.
 - a. Trace two black leads from on/off switch and separate them from any connections. Connect ohmmeter leads to switch leads, and check for continuity in both switch positions.

Condition	Conclusion
Continuity should be indicated when and only when switch is in OFF position.	Replace switch for any other results.

General Wiring Diagram

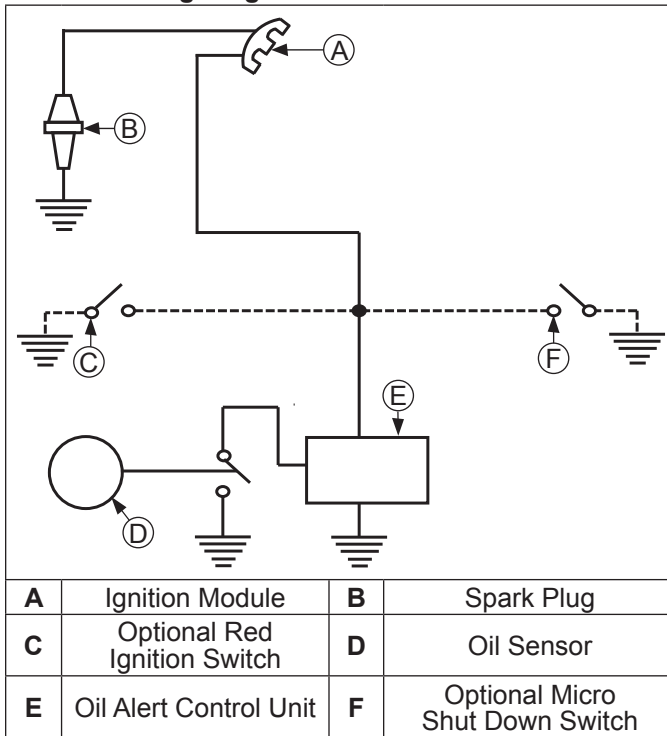

Starter System

NOTE: Do not crank engine continuously for more than 10 seconds. Allow a 60 second cool down period between starting attempts. Failure to follow these guidelines can burn out starter motor.

NOTE: If engine develops sufficient speed to disengage starter but does not keep running (a false start), engine rotation must be allowed to come to a complete stop before attempting to restart engine. If starter is engaged while flywheel is rotating, starter pinion and flywheel ring gear may clash, resulting in damage of starter.

NOTE: If starter does not crank engine, shut off starter immediately. Check condition of inline fuse and do not make further attempts to start engine until condition is corrected.

NOTE: Do not drop starter or strike starter housing. Doing so can damage starter.

Engines in this series use inertia drive electric starters or retractable starters. Inertia drive electric starters are not serviceable.

Troubleshooting-Starting Difficulties

Condition	Possible Cause	Conclusion
Starter does not energize.	Battery	Check specific gravity of battery. If low, recharge or replace battery as necessary.
	Wiring	Check fuse condition. Clean corroded connections and tighten loose connections. Replace wires in poor condition and with frayed or broken insulation.
	Starter Switch or Solenoid	Check switch or relay operation. If starter cranks normally, replace faulty components.
Starter energizes but turns slowly.	Battery	Check specific gravity of battery. If low, recharge or replace battery as necessary.
	Wiring	Check for corroded connections, poor ground connection.
	Transmission or Engine	Make sure clutch or transmission is disengaged or placed in neutral. This is especially important on equipment with hydrostatic drive. Transmission must be exactly in neutral to prevent resistance which could keep engine from starting. Check for seized engine components such as bearings, connecting rod, and piston.

Electric Starting System Tests

1. Test battery on unit.
 - a. Connect a DC voltmeter across battery terminals and read battery voltage (key switch OFF).
 - b. Turn key switch to start position and read battery voltage again. Turn switch OFF.

Condition	Conclusion
Voltage less than 12 volts.	Charge battery.
Battery voltage should not fall below 9 volts during cranking.	If it does, battery may be faulty or there may be a short in starting circuit. Have battery load tested. If battery passes load test, check circuitry.

2. Remove electric starter cover panel and check fuse inside plastic holder. Fuse outside holder is a spare.

Condition	Conclusion
Fuse is blown.	Check for a wiring problem (bare wire, short circuit). Correct problem and replace fuse. Try to start engine. If it still won't start, go to step 3.

3. Disconnect blue relay lead. Be sure transmission is in neutral and PTO is OFF. Connect one end of a jumper lead to positive terminal of battery. Connect other end to terminal of relay.

Condition	Conclusion
Relay engages and starter begins to crank.	Key switch is faulty, or there is a wiring problem to/from key switch. Check wiring and test key switch circuits with an ohmmeter.

4. Use a known, good, fully-charged battery and jumper cables to test starter motor. Be sure transmission is in neutral and PTO is OFF.

Remove heavy lead from post terminal on starter. Connect one end of positive jumper cable to post terminal and connect other end to positive terminal of battery.

Connect one end of negative jumper cable to negative terminal of battery. Touch other end of negative jumper cable to a bare surface on crankcase or to starter housing.

Condition	Conclusion
Relay engages and starter begins to crank.	Key switch is faulty, or there is a wiring problem to/from key switch. Check wiring and test key switch circuits with an ohmmeter.

5. Disconnect leads from starter relay and remove it from starter for testing.
- a. Set an ohmmeter on Rx1 scale and zero meter. Connect one ohmmeter lead to terminal of blue lead from relay. Connect other ohmmeter lead to relay mounting bracket.

Condition	Conclusion
Meter reading less than 3.4 ohms, or an open circuit is indicated (infinity ohms).	Relay is faulty and must be replaced.

- b. With ohmmeter still on Rx1 scale, connect leads to two large post terminals. Meter should indicate an open circuit (infinity ohms, no continuity).
- c. Leave ohmmeter leads connected to large terminals. Connect a jumper lead from positive terminal of battery to terminal of blue relay lead. Connect another jumper lead from negative terminal of battery to relay mounting bracket.

Condition	Conclusion
When circuit is completed, applying 12 volts to energizing coil, an audible click should be heard as relay engages, and ohmmeter should then indicate continuity between large terminals.	Results are other than indicated, replace relay.

Starter System

RETRACTABLE STARTERS

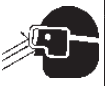
	⚠ WARNING	Retractable starters contain a powerful, recoil spring that is under tension. Always wear safety goggles when servicing retractable starters and carefully follow instructions in Retractable Starter for relieving spring tension.
	Uncoiling Spring can cause severe injury. Wear safety goggles or face protection when servicing retractable starter.	

Retractable Starter Components

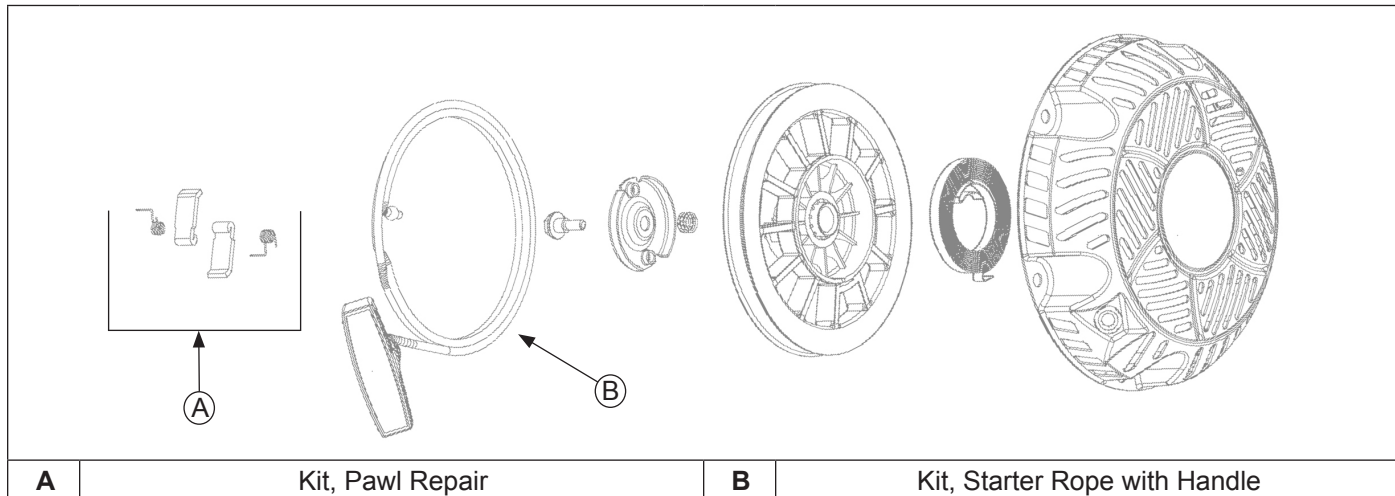

Remove Starter

1. Remove screws securing starter to blower housing.
2. Remove starter assembly.

Rope Replacement

NOTE: Do not allow pulley/spring to unwind. Enlist aid of a helper if necessary.

Rope can be replaced without complete starter disassembly.

1. Remove starter assembly from engine.
2. Pull rope out approximately 12 in. and tie a temporary (slip) knot in it to keep it from retracting into starter.
3. Pull knot end out of handle, untie knot, and slide handle off.
4. Hold pulley firmly and untie slipknot. Allow pulley to rotate slowly as spring tension is released.
5. When all spring tension on starter pulley is released, remove rope from pulley.
6. Tie a double left-hand knot in one end of new rope.
7. Rotate pulley counterclockwise to pre-tension spring (approximately 4 full turns of pulley).
8. Continue rotating pulley counterclockwise until rope hole in pulley is aligned with rope guide bushing of starter housing.
9. Insert unknotted end of new rope through rope hole in starter pulley and rope guide bushing of housing.
10. Tie a slipknot approximately 12 in. from free end of rope. Hold pulley firmly and allow it to rotate slowly until slipknot reaches guide bushing of housing.

11. Insert starter rope through starter handle and tie a double, left-hand knot at end of starter rope. Insert knot into hole in handle.
12. Untie slip knot and pull on starter handle until starter rope is fully extended. Slowly retract starter rope into starter assembly. If recoil spring is properly tensioned, starter rope will retract fully and starter handle will stop against starter housing.

Pawls (dogs) Replacement

1. Install a clamp to hold pulley in starter housing and prevent it from rotating.
2. Unscrew center screw and lift off drive plate.
3. Note positions of pawls and pawl springs before removing. Remove parts from pulley.
4. Install pawl springs and pawls into pawl slots of pulley. All parts must be dry.
5. Position drive plate over pawls, aligning actuating slots in place with raised sections on each drive pawl. Torque center screw to 5-6 N·m (44-54 in. lb.).
6. Remove clamp and pull starter rope out part way to check operation of pawls.

Install Starter

1. Install retractable starter onto blower housing leaving screws slightly loose.
2. Pull starter handle out until pawls engage in drive cup. Hold handle in this position and tighten screws securely.

Disassembly/Inspection and Service

	<p>⚠ WARNING</p> <p>Accidental Starts can cause severe injury or death.</p> <p>Disconnect and ground spark plug lead(s) before servicing.</p>	<p>Before working on engine or equipment, disable engine as follows: 1) Disconnect spark plug lead(s). 2) Disconnect negative (-) battery cable from battery.</p>
---	--	---

External Engine Components

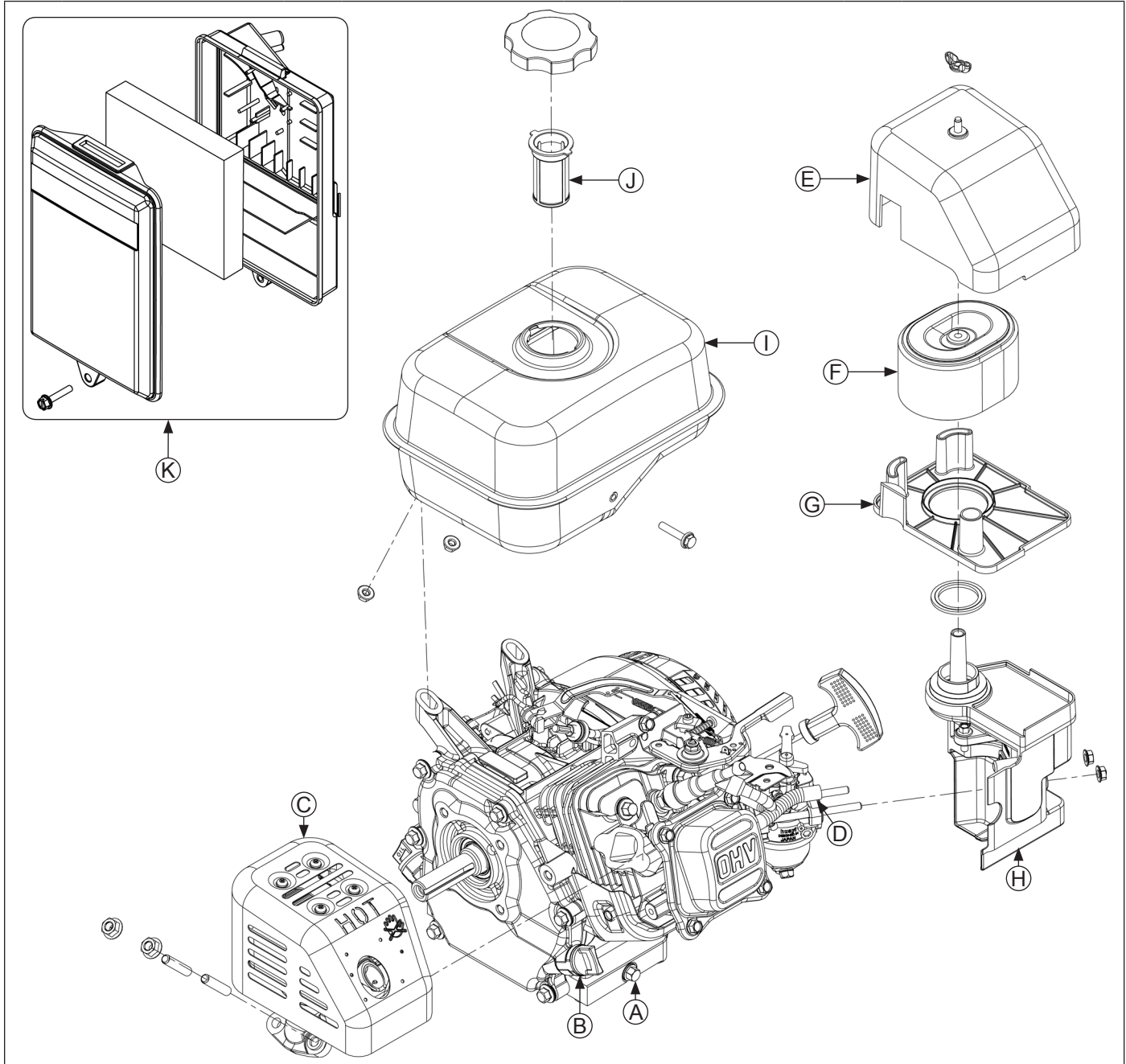

A	Oil Drain Plug	B	Oil Fill Plug	C	Muffler Assembly	D	Breather Hose
E	Air Cleaner Cover	F	Element/Precleaner	G	Air Cleaner Base	H	Carburetor Cover
I	Fuel Tank	J	Fuel Tank Filter	K	Low-Profile Air Cleaner		

Disassembly/Inspection and Service

Clean all parts thoroughly as engine is disassembled. Only clean parts can be accurately inspected and gauged for wear or damage. There are many commercially available cleaners that will quickly remove grease, oil, and grime from engine parts. When such a cleaner is used, follow manufacturer's instructions and safety precautions carefully.

Make sure all traces of cleaner are removed before engine is reassembled and placed into operation. Even small amounts of these cleaners can quickly break down lubricating properties of engine oil.

Disconnect Spark Plug Lead

NOTE: Pull on boot only, to prevent damage to spark plug lead.

1. Disconnect spark plug lead from spark plug.
2. Push fuel shut-off lever left to close fuel valve.

Drain Oil From Crankcase

1. Remove 1 oil drain plug and 1 oil fill plug.
2. Allow ample time for oil to drain from crankcase.

Remove Muffler and Heat Shield Assembly

1. Remove nuts, lock washers, and flat washers.

2. Remove muffler assembly from exhaust outlet.
3. Remove exhaust gasket from exhaust outlet.

Remove Air Cleaner Assembly

Remove air cleaner base from engine as follows:

1. Remove screws securing base of air cleaner assembly to engine.
2. Disconnect breather hose and remove base of air cleaner assembly.
3. Remove nuts and carburetor cover.
4. Loosely install nuts on studs (to temporarily hold carburetor on engine).

Remove Fuel Tank

1. Ensure fuel tank is empty.
2. Loosen clamp and disconnect fuel line from inlet of shut-off valve.
3. Remove nuts.
4. Remove screw and fuel tank while guiding fuel hose through engine bracket.

Blower Housing/Control Panel Components

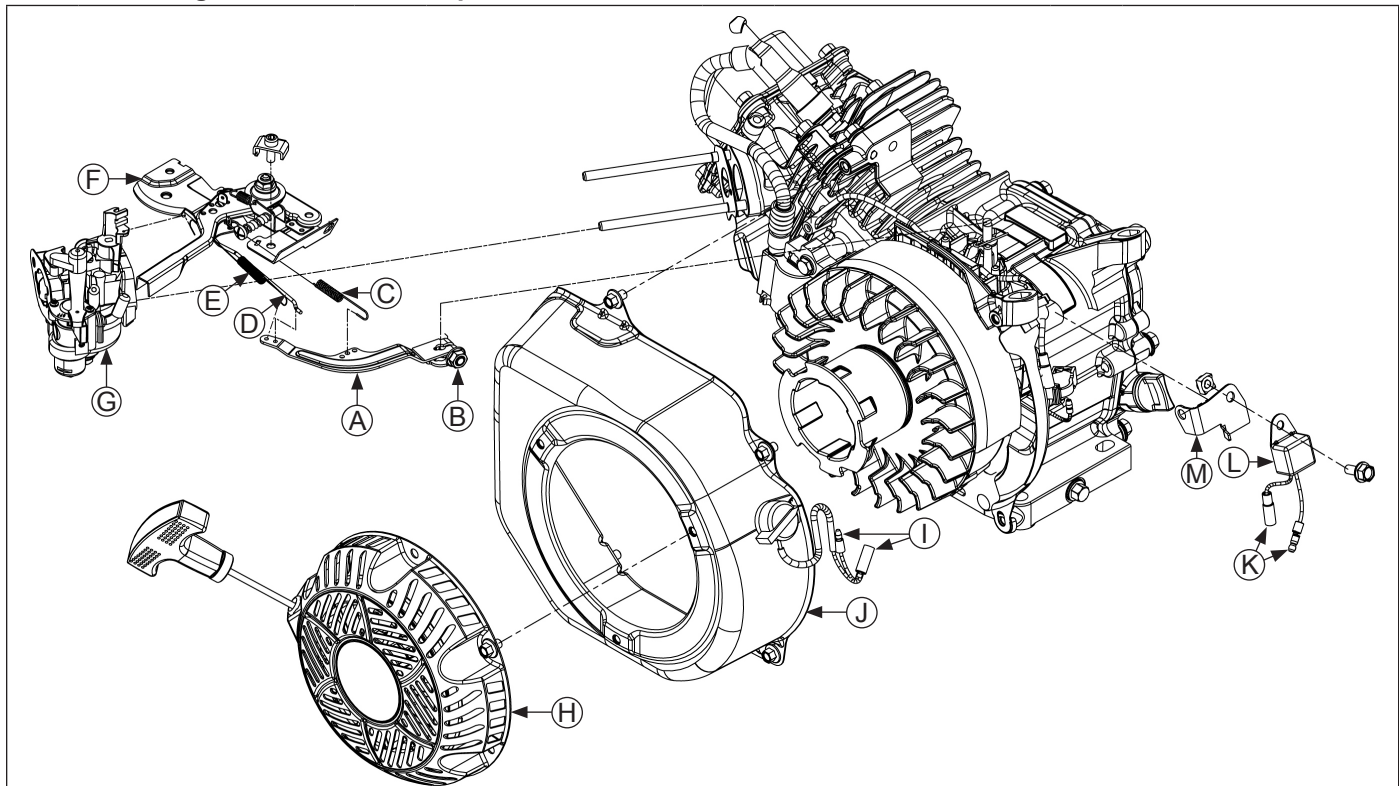

A	Governor Lever	B	Nut	C	Governor Spring	D	Throttle Link
E	Dampening Spring	F	Control Assembly	G	Carburetor	H	Retractable Starter
I	On/Off Wiring Harness Bullet Connector	J	Blower Housing	K	Oil Sentry™ Wiring Harness Bullet Connector	L	Oil Sentry™ Module
M	Oil Sentry™ Bracket						

Disassembly/Inspection and Service

Remove External Throttle, Governor and Choke Linkage

1. Mark hole in which governor spring is attached and loosen nut securing governor lever arm to governor shaft. Lift off governor lever and remove carburetor throttle link, dampening spring, and governor spring from governor lever.
2. Remove nut securing throttle control lever. Unhook spring and remove throttle control lever.
3. Remove screws and throttle plate.

Remove Carburetor

	⚠ WARNING
	<p>Explosive Fuel can cause fires and severe burns.</p> <p>Do not fill fuel tank while engine is hot or running.</p>
<p>Gasoline is extremely flammable and its vapors can explode if ignited. Store gasoline only in approved containers, in well ventilated, unoccupied buildings, away from sparks or flames. Spilled fuel could ignite if it comes in contact with hot parts or sparks from ignition. Never use gasoline as a cleaning agent.</p>	

Remove air cleaner gasket and slide carburetor off mounting studs while disconnecting throttle linkage and dampening spring. Remove carburetor to insulator gasket, insulator, and insulator to cylinder head gasket.

Remove Retractable Starter

Remove screws securing retractable starter assembly to blower housing.

Remove Electric Starter (if equipped)

Remove screws securing electric starter to blower housing.

Remove Blower Housing

1. Remove screws securing blower housing.
2. Release wiring harness bundle clamp and disconnect ON/OFF wiring harness bullet connectors.
3. Remove blower housing.

Remove Oil Sentry™ Module

Disconnect wiring harness bullet connector between Oil Sentry™ switch and module. Remove screw securing module to bracket.

Cylinder Head Components

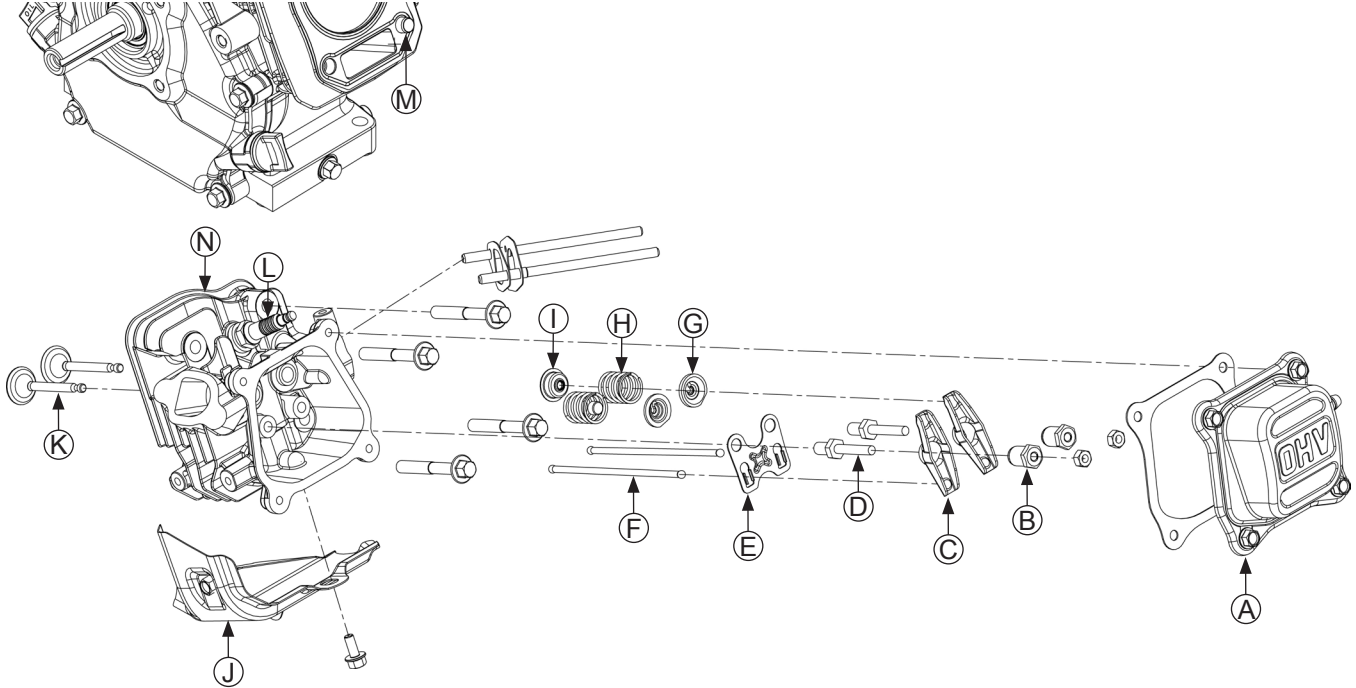

A	Valve Cover	B	Adjusting Nut	C	Rocker Arm	D	Rocker Arm Stud
E	Push Rod Guide	F	Push Rod	G	Valve Keeper	H	Valve Spring
I	Intake Valve Stem Seal	J	Cylinder Shroud	K	Valve	L	Spark Plug
M	Dowel Pins	N	Cylinder Head				

Disassembly/Inspection and Service

Remove Valve Cover/Breather, Rocker Arms, Push Rods and Cylinder Head Assembly

NOTE: Mark location of push rods and any other part removed that will be reused.

Valve Cover with Gasket

1. Remove screws and remove valve cover and gasket from engine. Breather assembly is inside valve cover.
2. Remove screws securing cylinder shroud and remove cylinder shroud.
3. Loosen and remove rocker arm lock nuts and adjuster nuts. Remove rocker arms and push rods.
4. Remove spark plug.
5. Remove screws securing cylinder head.
6. Remove cylinder head, dowel pins, and cylinder head gasket.

Valve Cover with RTV Sealant

NOTE: Valve cover is sealed to cylinder head using RTV silicone sealant. When removing valve cover, use care not to damage gasket surfaces of cover and cylinder head. To break RTV seal, hold block of wood against 1 flat surface of valve cover. Strike wood firmly with mallet. If seal doesn't break loose after 1 or 2 attempts, repeat procedure on other side.

1. Remove screws and remove valve cover from engine. Breather assembly is inside valve cover.
2. Using a brass wire brush and gasket remover or similar solvent, clean old RTV from surface of cylinder head and valve cover.
3. Remove screws securing cylinder shroud and remove cylinder shroud.
4. Loosen and remove rocker arm lock nuts and adjuster nuts. Remove rocker arms and push rods.
5. Remove spark plug.
6. Remove screws securing cylinder head.
7. Remove cylinder head, dowel pins, and cylinder head gasket.

Remove Valves

NOTE: Mark location of any part removed that will be reused.

1. Supporting head of valve from below, depress valve keeper and valve spring until keeper can be released from valve stem. Remove valve spring and valve from head. Repeat this procedure for remaining valve.
2. Remove and replace intake valve stem seal whenever cylinder head is serviced or disassembled.

Valve Details

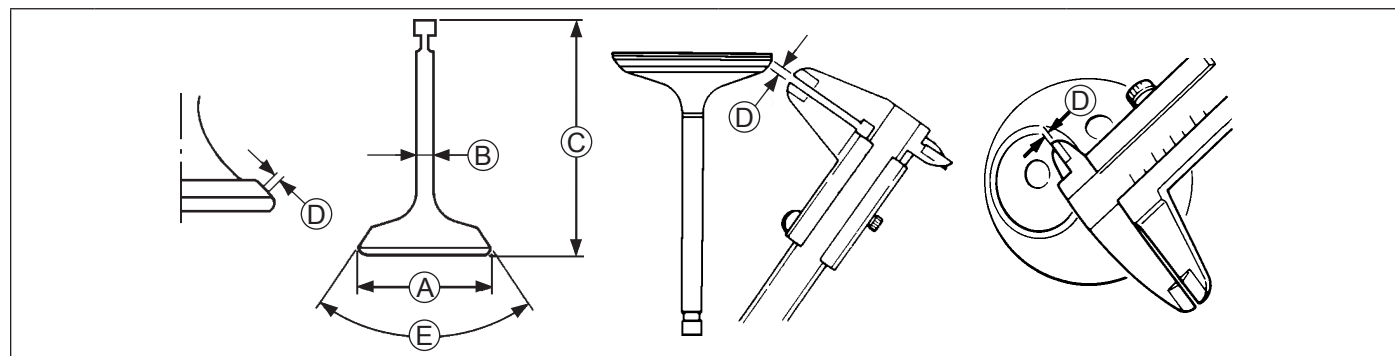

Item	Dimension	Intake	Exhaust
A	Head Diameter—Specification	25 mm + 0.1 mm (0.9842 in. + 0.0039 in.)	24 mm + 0.1 mm (0.9449 in. + 0.0039 in.)
	Head Diameter—Maximum	25.1 mm (0.9881 in.)	24.1 mm (0.9488 in.)
	Head Diameter—Service Limit	24.9 mm (0.9803 in.)	23.9 mm (0.9409 in.)
B	Stem Diameter—Specification	5.5 mm (0.217 in.)	5.438 mm (0.214 in.)
	Stem Diameter—Maximum	5.491 mm (0.216 in.)	5.430 mm (0.214 in.)
	Stem Diameter—Service Limit	5.340 mm (0.210 in.)	5.280 mm (0.208 in.)
C	Valve Length—Specification	64 mm + 0.15 mm (2.5197in. + 0.0059 in.)	62 mm + 0.15 mm (2.4409 in. + 0.0059 in.)
	Valve Length—Maximum	64.15 mm (2.5256 in.)	62.15 mm (2.4468 in.)
	Valve Length—Service Limit	64.15 mm (2.5256 in.)	62.15 mm (2.4468 in.)
D	Face/Seat Width—Maximum	2.0 mm (0.079 in.)	2.0 mm (0.079 in.)
E	Face/Seat Angle	90°-90.5°/89.5°-90°	90-90.5°/89.5°-90°
	Stem to Guide—Specification	0.024 mm (0.0009 in.)	0.098 mm (0.0038 in.)
	Stem to Guide—Maximum	0.039 mm (0.0015 in.)	0.112 mm (0.0044 in.)
	Stem to Guide—Service Limit	0.10 mm (0.0039 in.)	0.12 mm (0.0047 in.)
	Stem to Guide Running Clearance—Specification	0.020 mm (0.0008 in.)	0.030 mm (0.0008 in.)
	Stem to Guide Running Clearance—Maximum	0.044 mm (0.0017 in.)	0.054 mm (0.0021 in.)
	Stem to Guide Running Clearance—Service Limit	0.10 mm (0.0039 in.)	0.12 mm (0.0047 in.)
	Valve Guide – Specification	5.5 mm (0.2165 in.)	5.5 mm (0.2165 in.)
Valve Guide – Maximum	5.512 mm (0.2170 in.)	5.512 mm (0.2170 in.)	

Disassembly/Inspection and Service

Inspection and Service

After cleaning, check flatness of cylinder head and corresponding top surface of crankcase, using a surface plate or piece of glass and feeler gauge. Maximum allowable out of flatness is 0.1 mm (0.0039 in.).

Carefully inspect valve mechanism parts. Inspect valve springs and related hardware for excessive wear or distortion. Check valves and valve seats for evidence of deep pitting, cracks, or distortion. Check running clearance between valve stems and guides.

Hard starting, or loss of power accompanied by high fuel consumption may be symptoms of faulty valves. Although these symptoms could also be attributed to worn rings, remove and check valves first. After removal, clean valve heads, faces, and stems with a power wire brush.

Then, carefully inspect each valve for defects such as warped head, excessive corrosion, or worn stem end. Replace valves found to be in bad condition.

Valve Guides

If a valve guide is worn beyond specifications, it will not guide valve in a straight line. This may result in burned valve faces or seats, loss of compression, and excessive oil consumption.

To check valve guide-to-valve stem clearance, thoroughly clean valve guide and, using a split-ball gauge, measure inside diameter of guide. Then, using an outside micrometer, measure diameter of valve stem at several points on stem where it moves in valve guide. Use largest stem diameter to calculate clearance by subtracting stem diameter from guide diameter. If intake or exhaust clearance exceeds specifications in Valve Specification table, determine whether valve stem or guide is responsible for excessive clearance.

If guides are within limits but valve stems are worn beyond limits, install new valves.

Valve Seat Inserts

Hardened steel alloy intake and exhaust valve seat inserts are press-fitted into cylinder head. Inserts are not replaceable but can be reconditioned if not too badly pitted or distorted. If cracked or badly warped, cylinder head should be replaced.

Recondition valve seat inserts following instructions provided with valve seat cutter being used. Cutting proper valve face angle, as specified in Clearance Specifications table and proper valve seat angle (89.5°-90°) will achieve desired 0° (1° full cut) interference angle where maximum pressure occurs on outside diameters of valve face and seat.

Lapping Valves

Reground or new valves must be lapped in, to provide proper fit. Use a hand valve grinder with a suction cup for final lapping. Lightly coat valve face with a fine grade of grinding compound, then rotate valve on seat with grinder. Continue grinding until a smooth surface is obtained on seat and on valve face. Thoroughly clean cylinder head in hot, soapy water to remove all traces of grinding compound. After drying cylinder head, apply a light coating of SAE 10 oil to prevent rusting.

Intake Valve Stem Seal

Some engines use a valve stem seal on intake valve.

Always use a new seal when valves are removed from cylinder head. Seals should also be replaced if deteriorated or damaged in any way. Never reuse an old seal.

Flywheel/Ignition Components

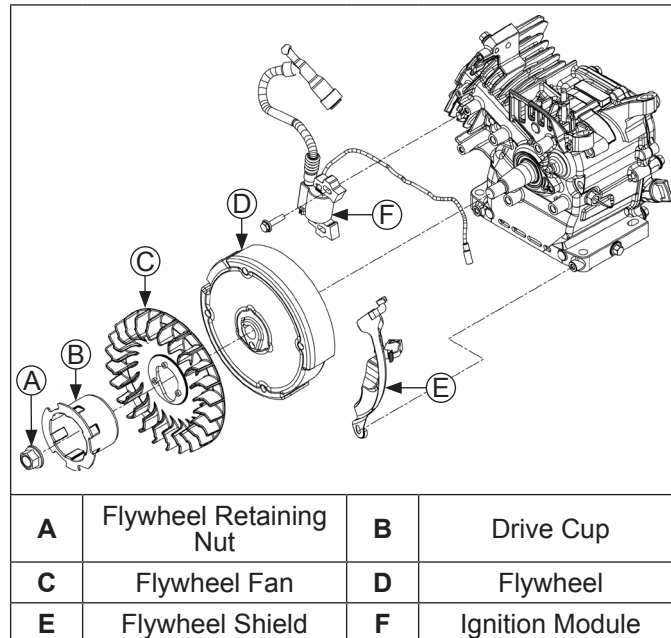

Remove Ignition Module

Remove screws securing ignition module to crankcase. Remove module.

Remove Flywheel

NOTE: Whenever possible, an impact wrench should be used to loosen flywheel retaining nut. A flywheel strap wrench may be used to hold flywheel when loosening or tightening flywheel retaining nut.

NOTE: Always use a puller to remove flywheel from crankshaft. Do not strike flywheel or crankshaft as these parts could become cracked or damaged.

1. Remove flywheel retaining nut.
2. Remove drive cup and fan from flywheel.
3. Remove screw and shield on right side of flywheel (required for use of puller in next step).
4. Remove flywheel from crankshaft using a suitable puller.
5. Remove flywheel key from crankshaft keyway.

Inspection

Inspect flywheel for cracks and flywheel keyway for damage. Replace flywheel if it is cracked. Replace flywheel, crankshaft, and key if flywheel key is sheared or keyway is damaged.

Crankcase Components

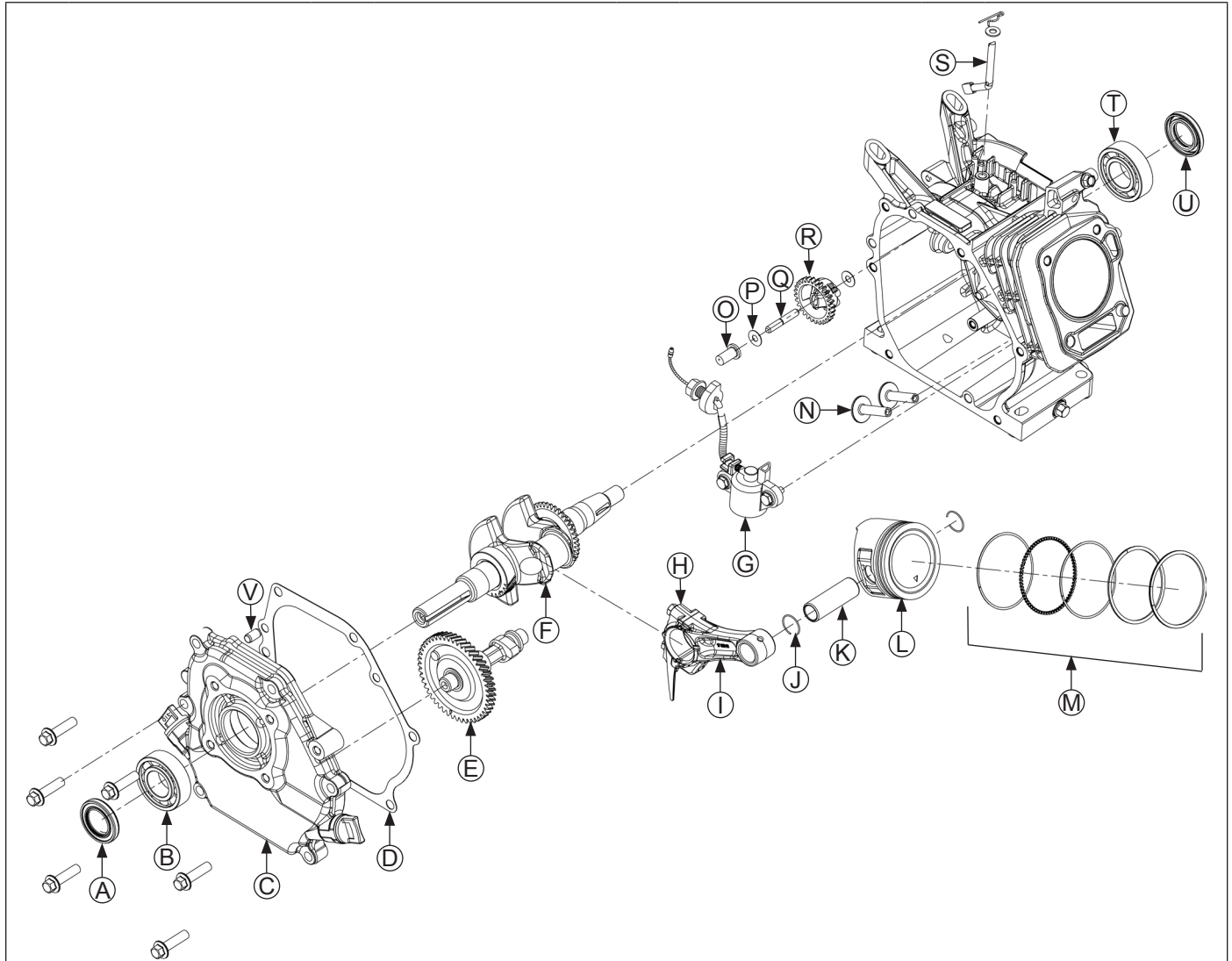

A	Closure Plate Oil Seal	B	Closure Plate Bearing	C	Closure Plate	D	Gasket
E	Camshaft	F	Crankshaft	G	Oil Sentry™ Float Switch	H	End Cap
I	Connecting Rod	J	Piston Pin Retainer	K	Piston Pin	L	Piston
M	Piston Ring Set	N	Tappet	O	Governor Cup	P	Governor Washer
Q	Governor Shaft	R	Governor Gear	S	Governor Cross Shaft	T	Crankcase Bearing
U	Crankcase Oil Seal	V	Dowel Pin				

Remove Closure Plate

NOTE: Do not pry on gasket surface of crankcase or closure plate, as this can cause damage and leakage.

1. Remove screws securing closure plate to crankcase.
2. Remove closure plate, gasket, and dowel pins (if required) from crankcase.

Inspection

Inspect oil seal in closure plate and remove it if it is worn or damaged. New oil seal can be installed after closure plate is assembled to crankcase. See Reassembly for oil seal installation instructions.

Inspect main bearing surface for wear or damage (refer to Specifications). Replace closure plate if required.

Disassembly/Inspection and Service

Remove Camshaft and Valve Tappets

1. Remove camshaft by pulling it straight out of crankcase.
2. Remove valve tappets by pulling straight out of crankcase. Mark their positions.

Inspection and Service

Inspect gear teeth of camshaft. If teeth are badly worn or chipped, or if some are missing, replacement of camshaft will be necessary. If unusual wear or damage is evident on either camshaft lobes or mating tappets camshaft and both tappets must be replaced. Check condition and operation of Automatic Compression Release (ACR) mechanism.

Automatic Compression Release (ACR)

ACR Operation Details

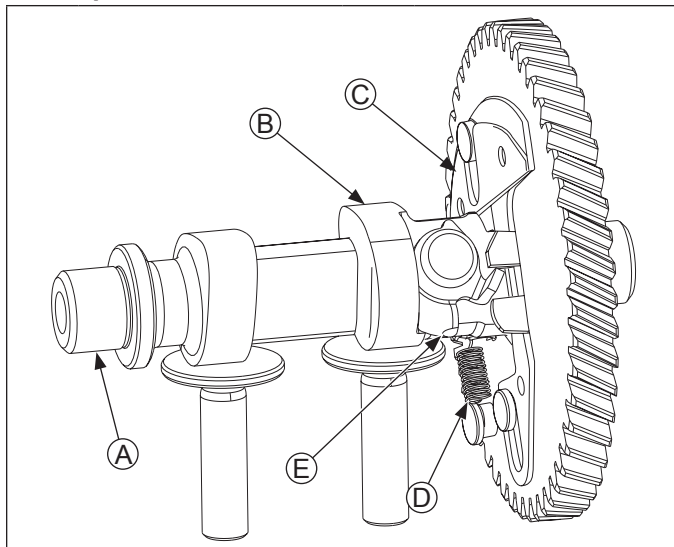

A	Camshaft	B	Exhaust Cam Lobe
C	Decompression Weight	D	Return Spring
E	Arm		

These engines are equipped with an ACR mechanism. ACR lowers compression at cranking speeds to make starting easier.

Operation

ACR mechanism consists of a decompression weight and arm mounted to camshaft, and activated by a return spring. When engine is rotating at low cranking speeds (1000 RPM or less), decompression weight holds arm so it protrudes above heel of exhaust lobe. This holds exhaust valve off its seat during first part of compression stroke.

After engine speed increases above approximately 1000 RPM, centrifugal force causes decompression weight to move outward, causing arm to retract. When in this position, arm has no effect on exhaust valve and engine operates at FULL compression and power.

Benefits

As a result of reduced compression at cranking speeds, several important benefits are obtained:

1. Manual (retractable) starting is much easier. Without ACR, manual starting would be virtually impossible.
2. Electric start models can use a smaller starter and battery that are more practical for application.
3. ACR eliminates need for a spark retard/advance mechanism. A spark retard/advance mechanism would be required on engines without ACR to prevent kickback that would occur during starting. ACR eliminates this kickback, making manual starting safer.
4. Choke control setting is less critical with ACR. If flooding occurs, excess fuel is blown out opened exhaust valve and does not hamper starting.
5. Engines with ACR start much faster in cold weather than engines without ACR.
6. Engines with ACR can be started with spark plugs that are worn or fouled. Engines without ACR are more difficult to start with those same spark plugs.

Remove Piston, Connecting Rod, and Crankshaft

NOTE: If a carbon ridge is present at top of cylinder bore, use a ridge reamer to remove it before attempting to remove piston.

1. Remove screws securing end cap to connecting rod. Remove end cap. While guiding connecting rod, slide piston and connecting rod from cylinder bore.
2. Remove crankshaft from crankcase.

Connecting Rod Inspection and Service

Check bearing area (big end) for excessive wear, score marks, running and side clearances. Replace connecting rod and end cap if scored or excessively worn.

Service replacement connecting rods are available in STD size.

Pistons and Rings Inspection

Scuffing and scoring of pistons and cylinder walls occurs when internal engine temperatures approach welding point of piston. Temperatures high enough to do this are created by friction, which is usually attributed to improper lubrication and/or overheating of engine.

Normally, very little wear takes place in piston boss or piston pin area. If original piston and connecting rod can be reused after new rings are installed, original pin can also be reused but new piston pin retainers are required. Piston pin is included as part of piston assembly; if pin boss in piston or pin itself is worn or damaged, a new piston assembly is required.

Ring failure is usually indicated by excessive oil consumption and blue exhaust smoke. When rings fail, oil is allowed to enter combustion chamber where it is burned along with fuel. High oil consumption can also occur when piston ring end gap is incorrect, because ring cannot properly conform to cylinder wall under this condition. Oil control is also lost when ring gaps are not staggered during installation.

When cylinder temperatures get too high, lacquer and varnish collect on pistons, causing rings to stick, which results in rapid wear. A worn ring usually takes on a shiny or bright appearance.

Scratches on rings and pistons are caused by abrasive material such as carbon, dirt, or pieces of hard metal.

Disassembly/Inspection and Service

Detonation damage occurs when a portion of fuel charge ignites spontaneously from heat and pressure shortly after ignition. This creates 2 flame fronts, which meet and explode to create extreme hammering pressures on a specific area of piston. Detonation generally occurs from using low octane fuels.

Preignition or ignition of fuel charge before timed spark can cause damage similar to detonation. Preignition damage is often more severe than detonation damage. Preignition is caused by a hot spot in combustion chamber such as glowing carbon deposits, blocked cooling fins, an improperly seated valve, or wrong spark plug.

Replacement pistons are available in STD bore size. Replacement pistons include new piston ring sets and new piston pins.

Replacement ring sets are also available separately for STD pistons. Always use new piston rings when installing pistons. Never use old rings.

Some important points to remember when servicing piston rings:

1. Cylinder bore must be deglazed before service ring sets are used.
2. If cylinder bore does not need reboring and if old piston is within wear limits and free of score or scuff marks, old piston may be reused.
3. Remove old rings and clean up grooves. Never reuse old rings.
4. Before installing new rings on piston, place top 2 rings, each in turn, in its running area in cylinder bore and check end gap. Compare ring gap to Clearance Specifications.
5. After installing new compression (top and middle) rings on piston, check piston-to-ring side clearance. Compare clearance to Clearance Specifications. If side clearance is greater than specified, a new piston must be used.

Measuring Piston-to-Bore Clearance

Piston Detail

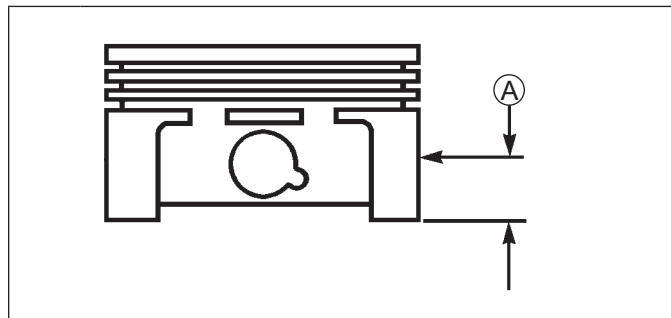

NOTE: Do not use a feeler gauge to measure piston-to-bore clearance, it will yield inaccurate measurements. Always use a micrometer.

Before installing piston into cylinder bore, it is necessary that clearance be accurately checked. This step is often overlooked, and if clearances are not within specifications, engine failure will usually result.

Use following procedure to accurately measure piston-to-bore clearance:

1. Use a micrometer and measure diameter of piston 15 mm (0.5905 in.) above bottom of piston skirt and perpendicular to piston pin.
2. Use an inside micrometer, telescoping gauge, or bore gauge and measure cylinder bore. Take measurement approximately 7.0 mm (0.2756 in.) below top of bore and perpendicular to piston pin.
3. Piston-to-bore clearance is difference between bore diameter and piston diameter (step 2 minus step 1).

Install New Piston Rings

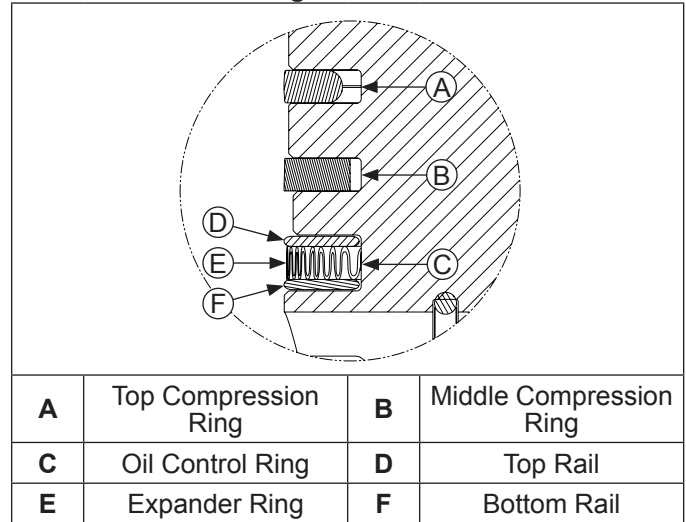

Piston Ring Orientation

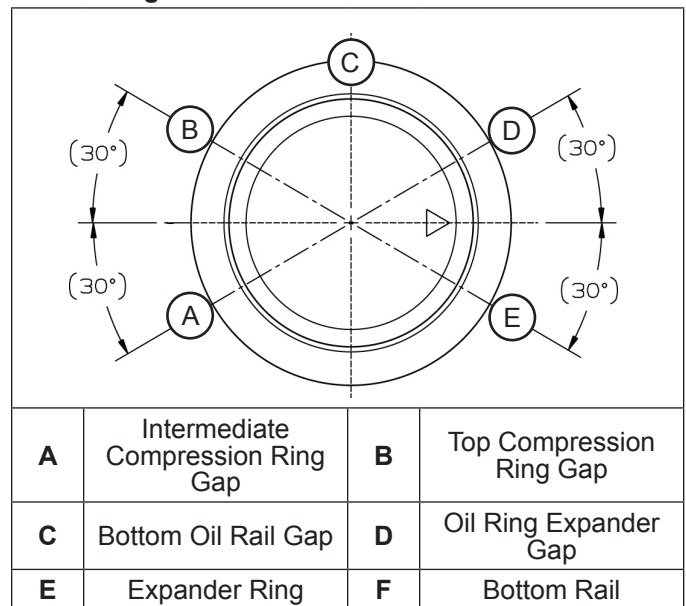

NOTE: Rings must be installed correctly. Install oil control ring assembly (bottom groove) first, middle compression ring (center groove) second, and top compression ring (top groove) last. Oil control ring assembly is a three-piece design, and consists of a top rail, expander ring, and bottom rail.

To install new piston rings, proceed as follows:
Use a piston ring expander to install rings.

Disassembly/Inspection and Service

1. Oil control ring assembly (bottom groove): Install expander first then bottom rail and top rail last. Make sure ends of expander are not overlapped. Adjust ring gaps.
2. Middle compression ring (center groove): Install middle compression ring using a piston ring expander tool. Make sure identification mark is up or colored dye stripe (if contained) is left of end gap. Adjust ring gaps.
3. Top compression ring (top groove): Install top compression ring using a piston ring expander tool. Make sure identification mark is up or colored dye stripe (if contained) is left of end gap. Adjust ring gaps.

Crankshaft Inspection and Service

Inspect gear teeth of crankshaft and ACR gear. If any teeth are badly worn or chipped, or if some are missing, replacement of crankshaft will be necessary.

Inspect crankshaft bearing surfaces for scoring, grooving, etc. Measure running clearance between crankshaft journals and their respective bearing bores. Use an inside micrometer or telescoping gauge to measure inside diameter of both bearing bores in vertical and horizontal planes. Use an outside micrometer to measure outside diameter of crankshaft main bearing journals. Subtract journal diameters from their respective bore diameters to get running clearances. Check results against values in specification tables. If running clearances are within specification, and there is no evidence of scoring, grooving, etc., no further reconditioning is necessary. If bearing surfaces are worn or damaged, crankcase and/or closure plate will need to be replaced.

Inspect crankshaft keyway. If worn or chipped, replacement of crankshaft will be necessary.

Inspect crankpin for score marks or metallic pickup. Slight score marks can be cleaned with crocus cloth soaked in oil. If wear limits in Specifications are exceeded, it will be necessary to replace crankshaft.

Remove Oil Sentry™ System

1. Remove nut securing Oil Sentry™ lead wire grommet assembly to crankcase.
2. Pull grommet assembly from crankcase on inside.
3. Remove screws securing Oil Sentry™ float switch to crankcase. Remove Oil Sentry™ float switch.

Remove Governor Assembly

NOTE: Mark location of all parts as governor assembly is removed.

1. Remove hitch pin from governor cross shaft.
2. Remove governor cross shaft from inside crankcase.
3. Remove cup and washer from governor gear.
4. Using a suitable drift, drive governor gear shaft from crankcase.

Inspection

Inspect governor gear teeth. Replace gear if it is worn, chipped, or if any teeth are missing. Inspect governor weights. They should move freely in governor gear.

Remove Crankcase and Closure Plate Seals and Bearings

1. Remove oil seal from crankcase.
2. Using a suitable press, drive crankshaft bearing from crankcase.
3. Remove oil seal from closure plate.
4. Using a suitable press, drive crankshaft bearing from closure plate.

Crankcase

Cylinder Bore Details

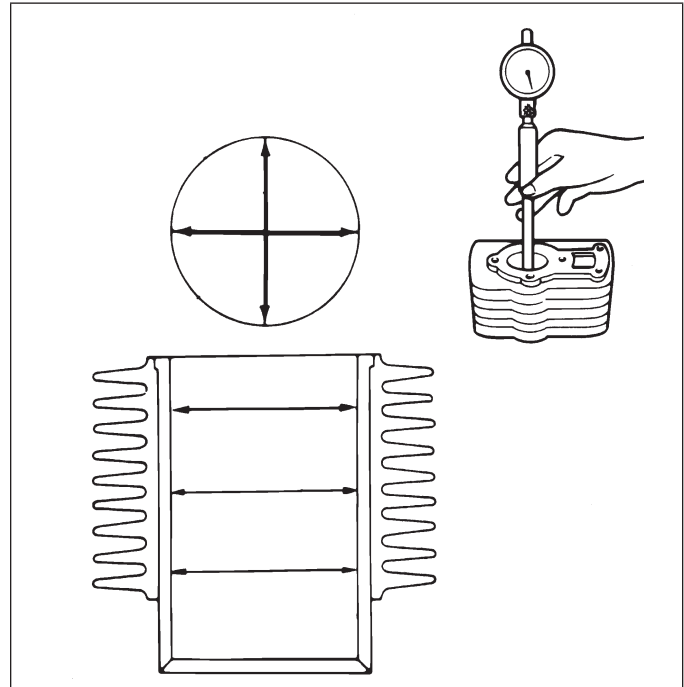

Inspection and Service

Check all gasket surfaces to make sure they are free of gasket fragments. Gasket surfaces must also be free of deep scratches or nicks.

Check cylinder bore for scoring. In severe cases, unburned fuel can cause scuffing and scoring of cylinder wall. It washes necessary lubricating oils off piston and cylinder wall. As raw fuel seeps down cylinder wall, piston rings make metal-to-metal contact with wall. Scoring of cylinder wall can also be caused by localized hot spots resulting from blocked cooling fins or from inadequate or contaminated lubrication.

If cylinder bore is badly scored, excessively worn, tapered, or out-of-round, replacement is necessary. Use an inside micrometer to determine amount of wear.

Breather Design

Breather system is designed to control amount of oil in head area and still maintain necessary vacuum in crankcase.

When pistons moves downward, crankcase gases are pushed past reed through mesh filter into intake system. Upward travel of pistons closes reed and creates a low vacuum in lower crankcase. Any oil separated out through filter drains back into crankcase.

Crankcase Components

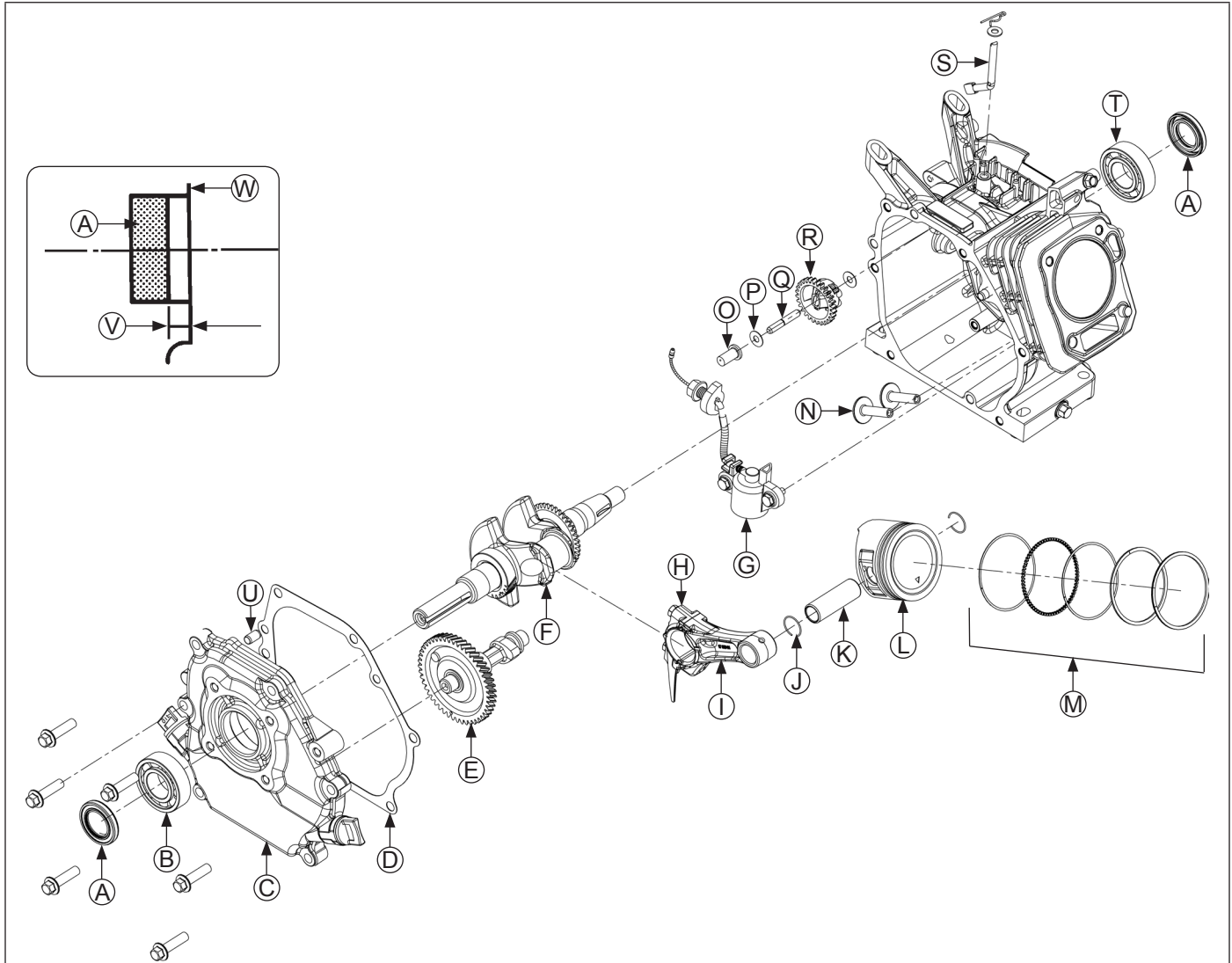

A	Oil Seal	B	Closure Plate Bearing	C	Closure Plate	D	Gasket
E	Camshaft	F	Crankshaft	G	Oil Sentry™ Float Switch	H	End Cap
I	Connecting Rod	J	Piston Pin Retainer	K	Piston Pin	L	Piston
M	Piston Ring Set	N	Tappet	O	Governor Cup	P	Governor Washer
Q	Governor Shaft	R	Governor Gear	S	Governor Cross Shaft	T	Crankcase Bearing
U	Dowel Pin	V	Oil Seal Depth	W	Outer Surface		

NOTE: Make sure engine is assembled using all specified torque values, tightening sequences, and clearances. Failure to observe specifications could cause severe engine wear or damage. Always use new gaskets.

Install Crankcase Bearings and Oil Seals

NOTE: Oil bearings liberally with engine oil when installing.

NOTE: In steps 3 and 4, position oil seals with manufacturer's identification marks visible and facing you.

1. Make sure there are no nicks, burrs, or damage in bores for bearings. Crankcase and closure plate must be clean.
2. Use an arbor press to make sure bearings are installed straight into their respective bore, until fully seated.
3. Using an appropriate seal driver, install oil seal into closure plate to a depth of 5.5 mm (0.217 in.) from outer surface.
4. Using an appropriate seal driver, install oil seal into crankcase to a depth of 0.0-1.0 mm (0.0-0.039 in.) from outer surface.

Reassembly

- Apply a light coating of lithium grease to seal lips after installing.

Install Governor Assembly

- Install governor shaft through gear and add thrust washer to shaft.
- Install governor gear assembly into crankcase using a press, or a drift with light taps, until tip of shaft is 78.862 mm (3.105 in.) below machined gasket surface of crankcase.
- Install thrust washer and cup on governor gear shaft.
- Install thrust washer onto governor cross shaft and slide shaft up through inside of crankcase.
- Install second flat washer onto shaft. Position shaft so flat index end of shaft faces left (9 o'clock position). Insert hitch pin so end of pin comes in contact with raised boss on housing, limiting inward movement of shaft.

Install Oil Sentry™ System

- Mount Oil Sentry™ float into crankcase using screws.
- Route wire lead grommet assembly through crankcase housing.
- Install nut onto grommet assembly external stud and tighten securely.

Install Crankshaft

Carefully slide flywheel end of crankshaft through main bearing and seal.

Install Connecting Rod with Piston and Rings

Connecting Rod Details

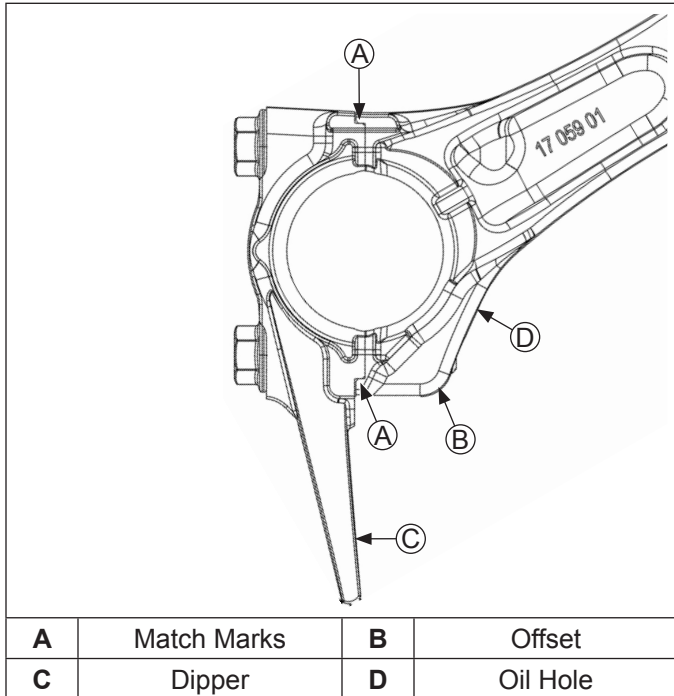

NOTE: If piston and/or connecting rod has been changed or removed, be sure piston index mark and end cap dipper orientation are correct before installation.

NOTE: Install oil control ring assembly first, middle compression ring second, and top compression ring last. Oil control ring assembly is a three-piece design, and consists of a top rail, expander ring, and bottom rail.

- Install piston with index mark on piston to connecting rod with dipper of end cap down.
- Install connecting rod with offset down and oil hole in 4 o'clock position shown. Match marks should align as shown.
- Install and stagger piston rings in grooves.
- Lubricate cylinder bore, piston, piston pin, and piston rings with engine oil. Compress rings using a piston ring compressor.
- Lubricate crankshaft journal and connecting rod bearing surfaces with engine oil.
- Be sure index mark on piston is facing down toward base of engine. Use a hammer handle or rounded wood dowel and gently tap piston into cylinder. Be careful oil ring rails do not spring free between bottom of ring compressor and top of cylinder.
- Install connecting rod end cap to connecting rod so dipper is down and match marks are aligned.
- Torque connecting rod screws in increments to 12 N·m (106 in. lb.).

Install Valve Tappets and Camshaft

Crankshaft and Camshaft Timing Marks

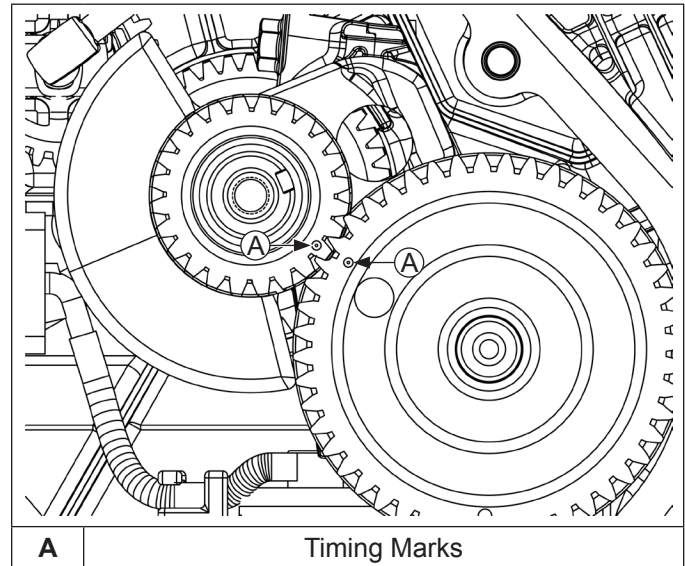

- Identify valve tappets as to their proper locations. Lubricate face and stem of each tappet with engine oil. Install each into its respective bore.
- Lubricate camshaft bearing surfaces and cam lobes as well as camshaft bore in crankcase with engine oil.
- Rotate crankshaft to TDC so timing mark (dimple) on crankgear (smaller gear) is in 4 o'clock position. Install camshaft into crankcase, aligning timing marks on gears.

Install Closure Plate

Torque Sequence

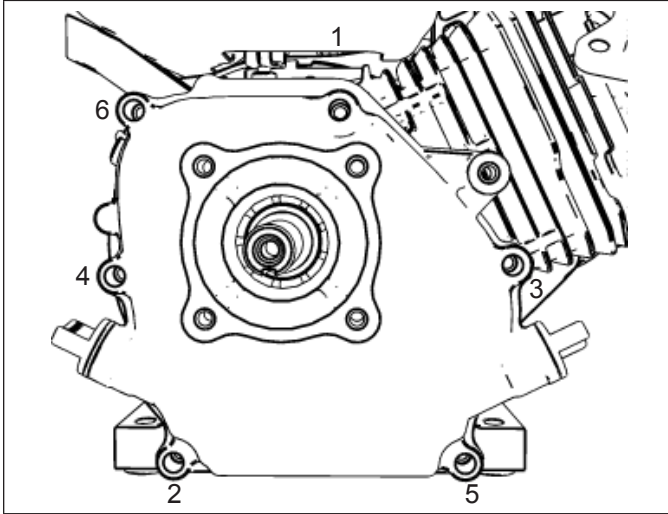

NOTE: Make sure governor lever is against cup on governor gear assembly.

1. Check to be sure sealing surfaces of crankcase and closure plate are clean and free of nicks or burrs.
2. Install dowel pins and install a new closure plate gasket (dry) onto dowel pins.
3. Install closure plate to crankcase. Carefully seat ends of camshaft and balance shaft into their mating bearings. Rotate crankshaft slightly to help engage governor gear teeth.
4. Install screws securing closure plate to crankcase. Torque screws in sequence shown to 24 N·m (212 in. lb.).

Flywheel/Ignition Components

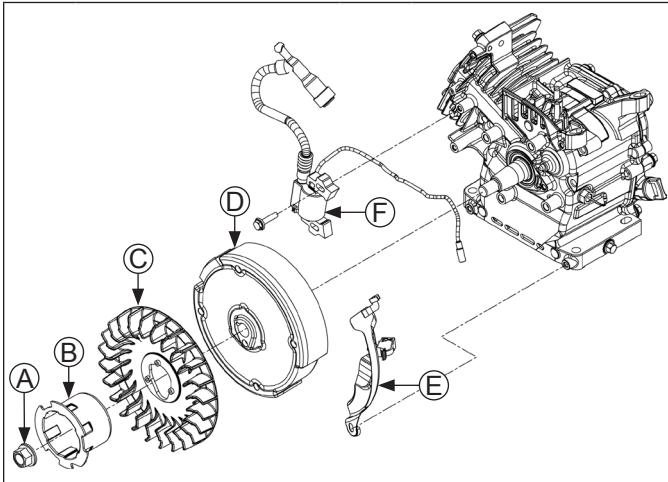

A	Flywheel Retaining Nut	B	Drive Cup
C	Flywheel Fan	D	Flywheel
E	Flywheel Shield	F	Ignition Module

Install Flywheel



CAUTION

Damaging Crankshaft and Flywheel can cause personal injury.

Using improper procedures can lead to broken fragments. Broken fragments could be thrown from engine. Always observe and use precautions and procedures when installing flywheel.

NOTE: Before installing flywheel make sure crankshaft taper and flywheel hub bore are clean, dry, and completely free of lubricants. Presence of lubricants can cause flywheel to be overstressed and damaged when nut is torqued to specification.

NOTE: Make sure flywheel key is installed properly in keyway. Flywheel can become cracked or damaged if key is not installed properly.

1. Install woodruff key into keyway of crankshaft. Be sure that key is properly seated and parallel with taper of shaft.
2. Install flywheel onto crankshaft, being careful not to shift position of woodruff key.
3. Install flywheel shield and secure with screw.
4. Install fan bosses into matching holes in flywheel.
5. Position drive cup on flywheel, engaging boss on its base with corresponding hole on flywheel. Hold in position and install nut. Finger tighten to keep cup indexed.
6. Use a flywheel strap wrench and torque wrench to tighten flywheel nut. Torque nut to 74 N·m (655 in. lb.).

Install Ignition Module

NOTE: Ensure ignition module is correctly oriented.

1. Turn flywheel so magnet is away from location where ignition module will be installed.
2. Install ignition module loosely to bosses with screws. Move module as far away from flywheel as possible, then tighten screws just enough to hold it in position.
3. Rotate flywheel in a clockwise direction until magnet is under 1 leg of ignition module.
4. Insert a 0.254 mm (0.010 in.) flat feeler gauge between leg of module and magnet. Loosen nearest screw, allowing magnet to draw module against feeler gauge. Push against module to hold leg tight against feeler gauge while tightening screw.
5. Rotate flywheel until magnet is under other leg of module. Loosen nearest screw, allowing magnet to draw module against feeler gauge. Push against module to hold leg tight against feeler gauge while tightening screw.
6. Torque both module screws to 8 N·m (70.8 in. lb.).
7. Rotate flywheel back and forth, checking to make sure magnet does not strike module.

Reassembly

8. Connect kill wire to ignition module bottom blade terminal and route wire lead across top of crankcase.

Cylinder Head Components

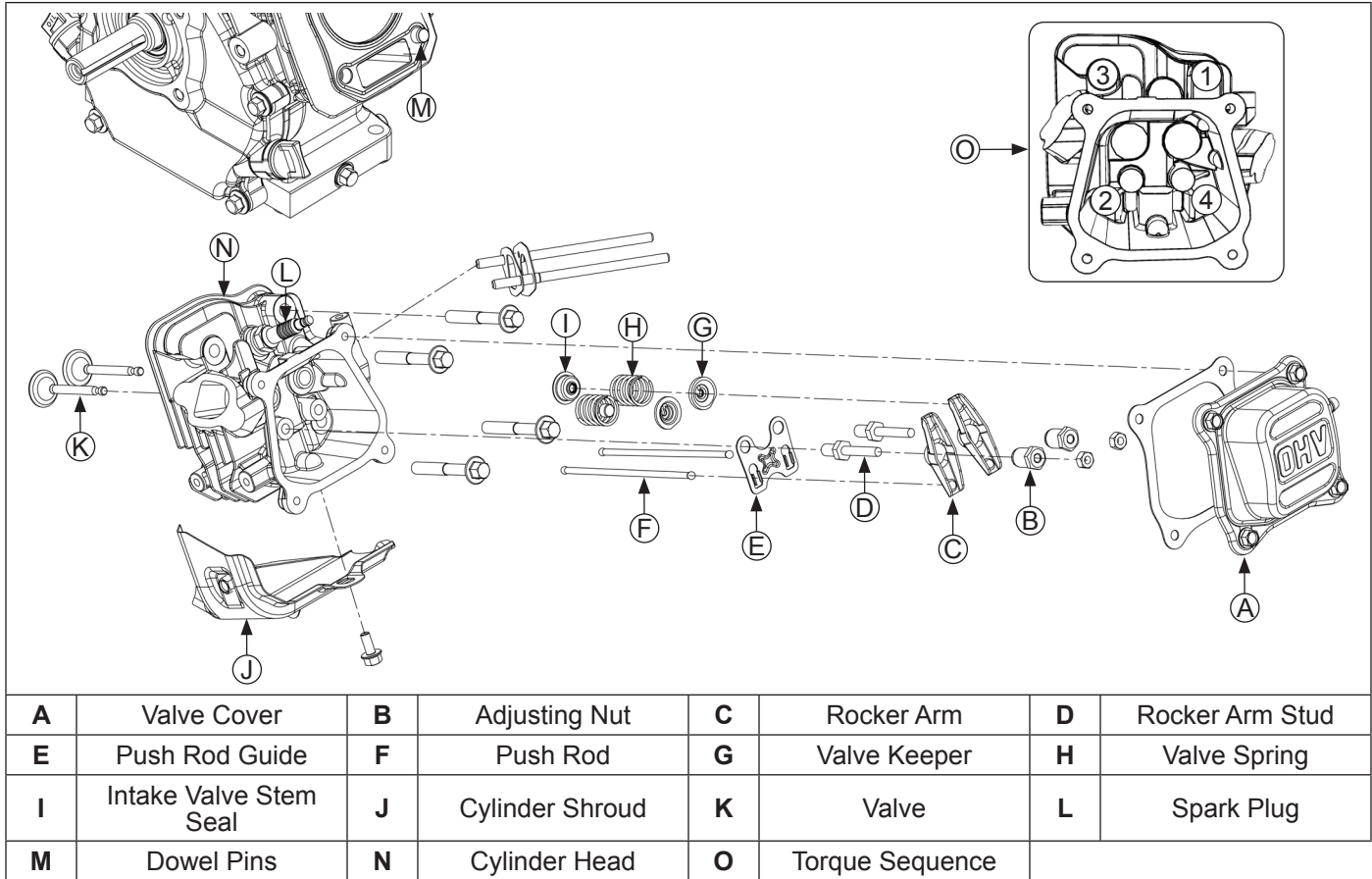

Assemble Cylinder Head

NOTE: Engine utilizes a valve stem seal on intake valve. Always use a new seal when valves are installed in cylinder head. Never reuse an old seal.

1. Install valves into their respective positions.
2. Install a new valve seal on stem of intake valve.
3. Install valve springs and retainers into their respective locations in cylinder head. Using hand pressure, compress each valve spring and slide each retainer onto valve stem to lock in place.

Install Cylinder Head

1. Check to make sure there are no nicks or burrs on sealing surfaces of cylinder head or crankcase.
2. Rotate crankshaft to position piston at TDC on compression stroke.
3. Install dowel pins into recesses around lower cylinder head bolt holes and install a new cylinder head gasket.
4. Install cylinder head and start screws. Tighten screws initially to a torque of 12 N·m (106 in. lb.) in several increments using sequence shown. Tighten to a final torque of 24 N·m (212 in. lb.).

Install Push Rods and Rocker Arms

NOTE: Push rods should always be installed in original location.

1. Install push rod guide plate, aligning holes for rocker arm studs. Install rocker arm studs and torque to 13.6 N·m (120 in. lb.).
2. Dip ends of push rods in engine oil and install them in their respective locations, seating each into tappet socket.
3. Assemble rocker arms, adjusters, and locknuts onto rocker arm studs and push rods.
4. Adjust valve tappet clearance as follows:
 - a. Be sure piston is still at top of compression stroke.
 - b. Insert a flat feeler gauge between rocker arm and valve stem. Recommended valve to rocker arm clearance for intake is 0.1 mm (0.0040 in.) and 0.15 mm (0.0060 in.) for exhaust.
 - c. Adjust clearance as required by loosening locknut and tightening adjuster.
Turn clockwise to decrease clearance.
Turn counterclockwise to increase clearance.

- d. Hold adjuster from turning and tighten locknut. Torque locknut to 10 N·m (88.5 in. lb.).
- e. Recheck that clearance is correct.
5. Set gap of new spark plug to 0.76 mm (0.030 in.).
6. Install spark plug in cylinder head and torque to 27 N·m (20 ft. lb.).

Install Valve Cover

Valve Cover Torque Sequence

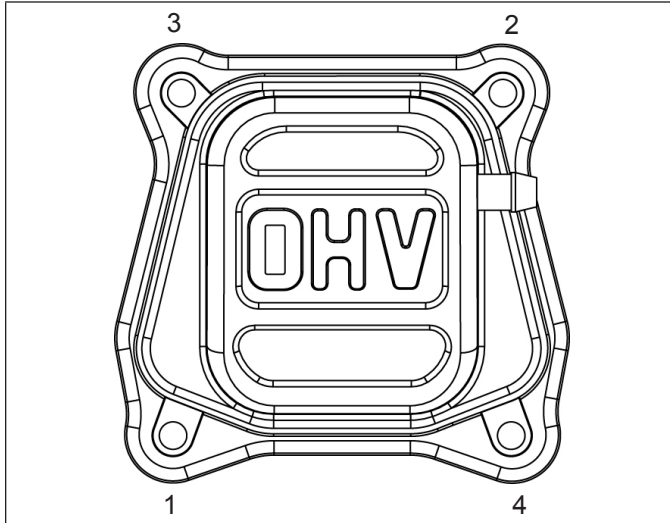

Valve Cover with Gasket

1. Make sure sealing surfaces of valve cover and cylinder head are clean, and free of any nicks or burrs.
2. Install a new valve cover gasket, followed by valve cover on head with screws and torque to 8.0 N·m (71 in. lb.) using sequence shown.

Valve Cover with RTV

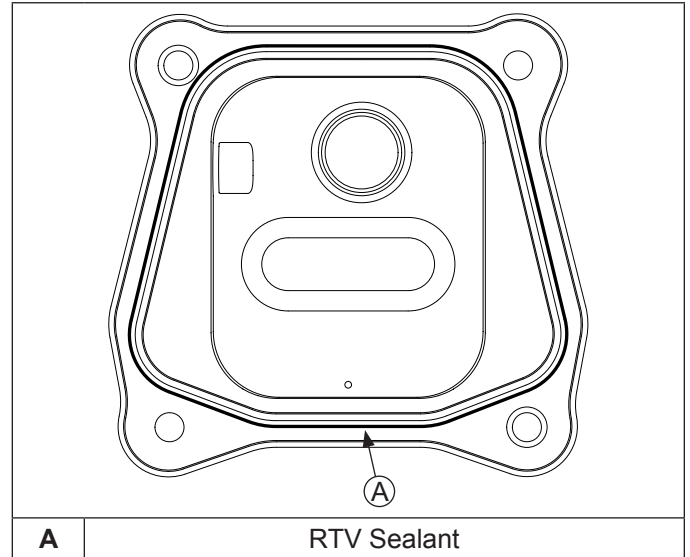

NOTE: Always use fresh sealant. Using outdated sealant can result in leakage. Refer to Tools and Aids for important information on sealant dispenser.

NOTE: To ensure proper adhesion of sealant to both surfaces, perform step 3 immediately (5 minutes maximum) after application of RTV.

1. Prepare sealing surface of cylinder head and valve cover.
2. Apply a 1.5 mm (1/16 in.) bead of sealant to valve cover as shown.
3. Position cover on cylinder head and start mounting screws.
4. Torque screws to 8.0 N·m (71 in. lb.) using sequence shown.

Reassembly

Blower Housing/Control Panel Components

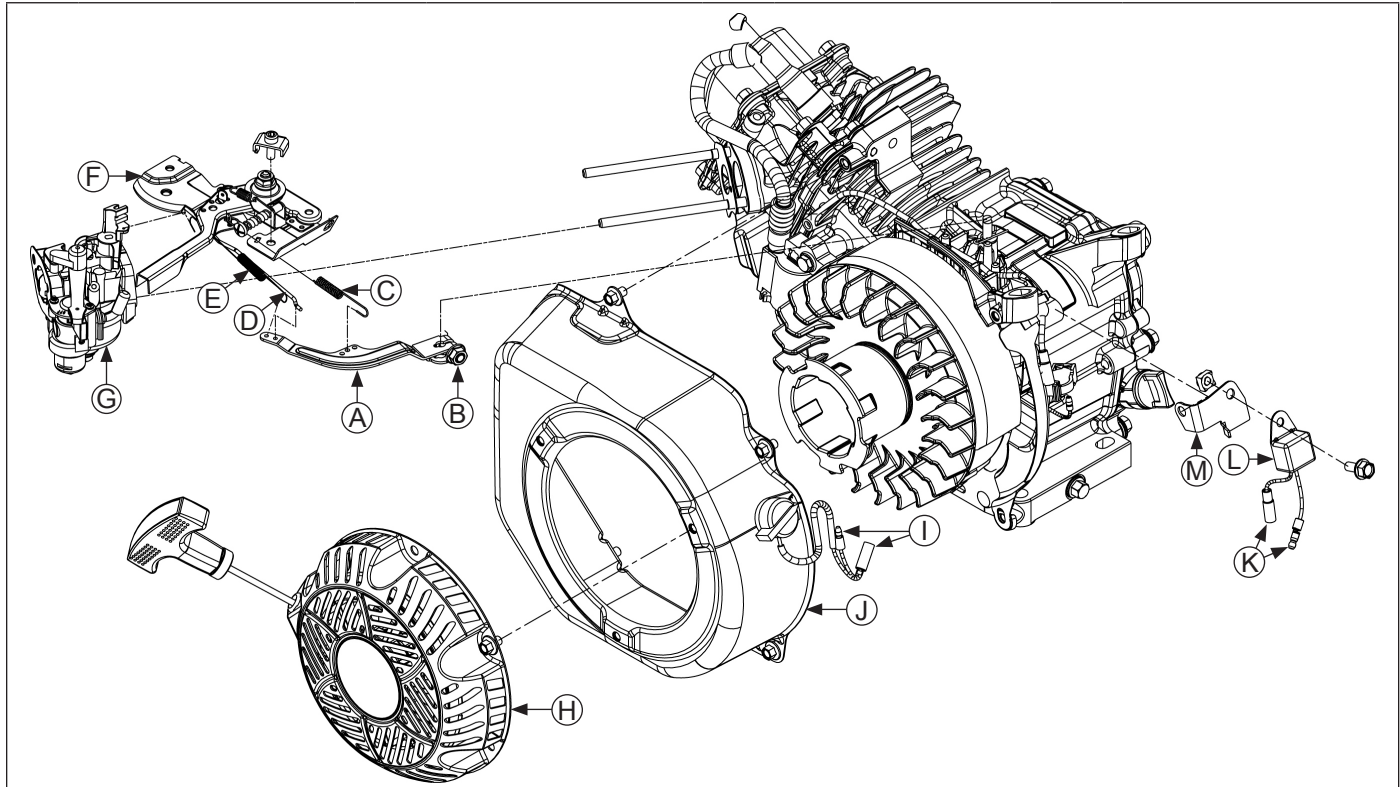

A	Governor Lever	B	Nut	C	Governor Spring	D	Throttle Link
E	Dampening Spring	F	Control Assembly	G	Carburetor	H	Retractable Starter
I	On/Off Wiring Harness Bullet Connector	J	Blower Housing	K	Oil Sentry™ Wiring Harness Bullet Connector	L	Oil Sentry™ Module
M	Oil Sentry™ Bracket						

Install Throttle Plate

Install throttle plate with screws.

Install Engine Air Shroud

Install cylinder shroud. Torque screws to 8 N·m (70.8 in. lb.).

Install Carburetor

1. Install a new insulator to cylinder head gasket onto carburetor studs, followed by insulator, carburetor to insulator gasket, carburetor, and air cleaner gasket.
2. Connect throttle link and dampening spring into their respective holes on throttle lever.

Install Blower Housing

1. Position spark plug lead in molded clip in carburetor insulator.
2. Install blower housing on crankcase with screws. Torque screws to 10 N·m (88.5 in. lb.).

Install Electric Starter and Control Panel (if equipped)

1. Align and mount electric starter onto crankcase. Install and torque screws to 24 N·m (212 in. lb.).
2. Connect electrical leads for Oil Sentry™, ignition module, key switch, relay, and starter.
3. Mount control panel to crankcase and secure with screws. Ensure ground wires are placed between screw and bracket. Torque screws to 24 N·m (212 in. lb.).

Install Retractable Starter

1. Install retractable starter on blower housing using screws. Finger tighten screws only.
2. Pull rope handle to engage pawls and center starter to drive cup. Hold in this position and torque screws to 5.4 N·m (47.8 in. lb.).

External Engine Components

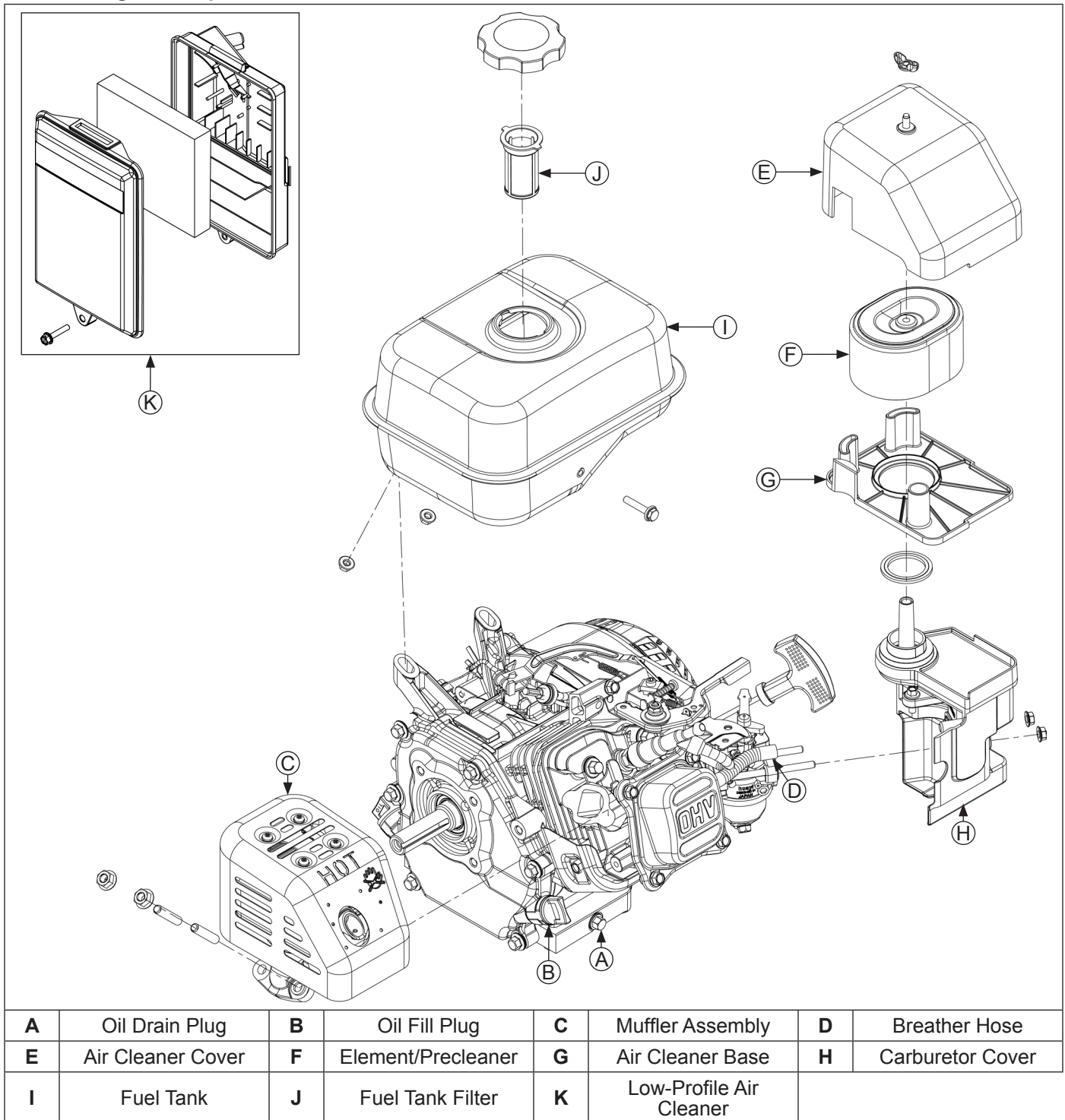

Reassembly

Install Throttle Lever, Governor Lever, Throttle Link, Dampening Spring, and Governor Spring

1. Install nylon washer and wave spring to throttle plate.
2. Connect spring to throttle lever and throttle plate. Install throttle lever to throttle plate. Install tabbed washer (with tab engaged in slot) and secure with nut.
3. Torque nut to 5.4 N·m (47.8 in. lb.).
4. Install governor lever onto shaft.
5. Connect dampening spring and throttle link to governor lever. Connect governor spring to governor lever and to throttle lever.
6. Move governor lever clockwise until it stops. Rotate governor shaft clockwise until it stops. Hold both in this position and torque governor lever nut to 10 N·m (88.5 in. lb.).

Governor Lever Hole Position/RPM Chart

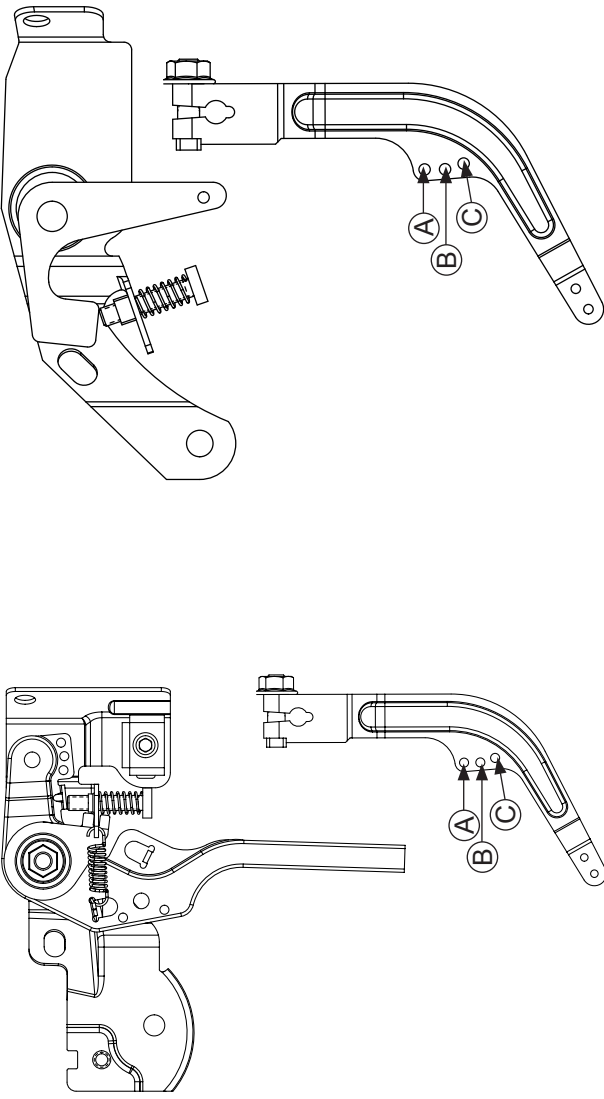

Engine Speed RPM	Droop													
	5-8%		5-10%		8-13%		8-14%		9-15%		14-18%		11-18%	
	Spring Color	Hole	Spring Color	Hole	Spring Color	Hole	Spring Color	Hole	Spring Color	Hole	Spring Color	Hole	Spring Color	Hole
3750-3950										None	B			
3100-3300							Gold	C						
3500-3700			Green		A									
3750-3950													Green	B
3601-3800			Black	B										
3001-3200	Black	B												
3800-4000														
3801-4000			Black		B							Purple	A	
3601-3800			Black		B									
3401-3600			Gold		C									
3201-3400			Gold		C									
3001-3200			Gold		B									
2800-3000			Gold		A									

Reassembly

Install Oil Sentry™ Module

1. Install Oil Sentry™ module and secure with screw.
2. Connect electrical leads for Oil Sentry™ module.

Install Fuel Tank

1. Route fuel line across top of engine toward carburetor while positioning fuel tank on mounting brackets.
2. Secure with screw on inner mounting bracket.
3. Install nuts on fuel tank studs.
4. Torque fuel tank screw and nuts to 24 N·m (212 in. lb.).
5. Position fuel line in clip at carburetor and connect fuel line to shut-off valve on carburetor. Secure clamp.

Install Carburetor Cover

Install outer air cleaner cover onto studs and secure with nuts.

Install Muffler and Heat Shield Assembly

1. Install a new exhaust gasket with muffler and heat shield assembly. Secure muffler and heat shield assembly with nuts.
2. Torque nuts to 8 N·m (70.8 in. lb.).

Install Air Cleaner Base, Element, and Cover

Dual-Element

1. Install air cleaner base and secure with screws.
2. Install paper element with precleaner onto air cleaner stud and secure with washer and wing nut (if equipped).
3. Install air cleaner cover and secure with wing nut.

Low-Profile

1. Install air cleaner base and secure with screws.
2. Install foam element (lightly oiled) into base.
3. Install cover and secure with screw.

Prepare Engine for Operation

Engine is now reassembled. Before starting or operating engine be sure to do following:

1. Make sure all hardware is properly torqued.
2. Make sure oil drain plugs, oil fill plugs, and Oil Sentry™ wire lead bullet connectors are tightened securely.
3. Fill crankcase with correct oil. Refer to Maintenance and Lubrication System for oil recommendations and procedures.

Testing Engine

NOTE: Do not adjust maximum no-load high-idle engine speed beyond 3950 RPM maximum.

It is recommended engine be operated on a test stand or bench prior to installation on a piece of equipment.

1. Set engine up on a test stand. Check gas and oil levels. Start engine and run for 5-10 minutes between idle and midrange. Adjust low-speed idle screw so low idle speed is set to 1800 RPM (± 150) or application specifications.
2. Adjust high-speed stop screw as necessary to 3850 ± 100 RPM (typical RPM).



1P18 690 01



6 50531 96540 0