

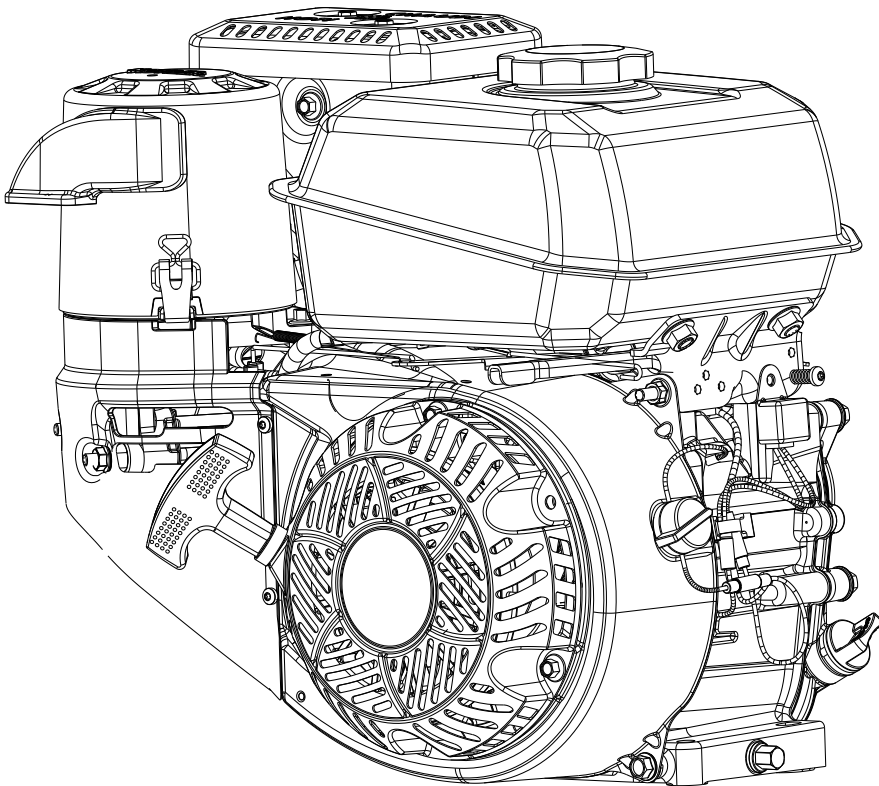

rehlko

Command PRO

CH245-CH440
Service Manual



Kohler Engines
is now Rehlko.



2	Safety
3	Maintenance
5	Specifications
19	Tools and Aids
22	Troubleshooting
27	Air Cleaner/Intake
29	Fuel System
33	Governor System
43	Lubrication System
44	Electrical System
51	Starter System
56	Gear Reduction System
69	Disassembly/Inspection and Service
91	Reassembly

IMPORTANT: Read all safety precautions and instructions carefully before operating equipment. Refer to operating instruction of equipment that this engine powers.

Ensure engine is stopped and level before performing any maintenance or service.

Safety

SAFETY PRECAUTIONS

⚠ WARNING: A hazard that could result in death, serious injury, or substantial property damage.

⚠ CAUTION: A hazard that could result in minor personal injury or property damage.

NOTE: is used to notify people of important installation, operation, or maintenance information.

	⚠ WARNING
	Explosive Fuel can cause fires and severe burns. Do not fill fuel tank while engine is hot or running.
Gasoline is extremely flammable and its vapors can explode if ignited. Store gasoline only in approved containers, in well ventilated, unoccupied buildings, away from sparks or flames. Spilled fuel could ignite if it comes in contact with hot parts or sparks from ignition. Never use gasoline as a cleaning agent.	

	⚠ WARNING
	Rotating Parts can cause severe injury. Stay away while engine is in operation.
Keep hands, feet, hair, and clothing away from all moving parts to prevent injury. Never operate engine with covers, shrouds, or guards removed.	

	⚠ WARNING
	Carbon Monoxide can cause severe nausea, fainting or death. Avoid inhaling exhaust fumes. Never run engine indoors or in enclosed spaces.
Engine exhaust gases contain poisonous carbon monoxide. Carbon monoxide is odorless, colorless, and can cause death if inhaled.	

	⚠ WARNING
	Accidental Starts can cause severe injury or death. Disconnect and ground spark plug lead(s) before servicing.
Before working on engine or equipment, disable engine as follows: 1) Disconnect spark plug lead(s). 2) Disconnect negative (-) battery cable from battery.	

	⚠ WARNING
	Hot Parts can cause severe burns. Do not touch engine while operating or just after stopping.
Never operate engine with heat shields or guards removed.	



	⚠ WARNING
	Cleaning Solvents can cause severe injury or death. Use only in well ventilated areas away from ignition sources.
Carburetor cleaners and solvents are extremely flammable. Follow cleaner manufacturer's warnings and instructions on its proper and safe use. Never use gasoline as a cleaning agent.	

	⚠ CAUTION
	Electrical Shock can cause injury. Do not touch wires while engine is running.

	⚠ CAUTION
	Damaging Crankshaft and Flywheel can cause personal injury.
Using improper procedures can lead to broken fragments. Broken fragments could be thrown from engine. Always observe and use precautions and procedures when installing flywheel.	

	⚠ WARNING
	Uncoiling Spring can cause severe injury. Wear safety goggles or face protection when servicing retractable starter.
Retractable starters contain a powerful, recoil spring that is under tension. Always wear safety goggles when servicing retractable starters and carefully follow instructions in Retractable Starter for relieving spring tension.	

MAINTENANCE INSTRUCTIONS

  	⚠ WARNING	Before working on engine or equipment, disable engine as follows: 1) Disconnect spark plug lead(s). 2) Disconnect negative (-) battery cable from battery.
	Accidental Starts can cause severe injury or death. Disconnect and ground spark plug lead(s) before servicing.	

Normal maintenance, replacement or repair of emission control devices and systems may be performed by any repair establishment or individual; however, warranty repairs must be performed by a Rehlko authorized dealer.

MAINTENANCE SCHEDULE

After first 5 Hours

<ul style="list-style-type: none"> Change engine oil (NOT required if using Xtended Life PRO 10W-50 full-synthetic oil). 	Lubrication System
---	--------------------

Every 8 Hours

<ul style="list-style-type: none"> Check oil bath air cleaner oil level in oil reservoir cup (if equipped). 	Air Cleaner/Intake
--	--------------------

Every 50 Hours

<ul style="list-style-type: none"> Change oil in 2:1 with Clutch Reduction System (CH245, CH255, CH270, CH395, CH440). 	Gear Reduction System
---	-----------------------

Every 50 Hours¹

<ul style="list-style-type: none"> Service/replace oil bath air cleaner foam filter or foam elements (if equipped). 	Air Cleaner/Intake
--	--------------------

Every 50 Hours or Annually (whichever comes first)

<ul style="list-style-type: none"> Service/replace Quad-Clean™ precleaner. 	Air Cleaner/Intake
---	--------------------

Every 100 Hours or Annually¹ (whichever comes first)

<ul style="list-style-type: none"> Clean low-profile air cleaner element. 	Air Cleaner/Intake
<ul style="list-style-type: none"> Change engine oil. 	Lubrication System
<ul style="list-style-type: none"> Clean cooling areas. 	Air Cleaner/Intake

Every 200 Hours

<ul style="list-style-type: none"> Replace Quad-Clean™ air cleaner element. 	Air Cleaner/Intake
--	--------------------

Every 300 Hours

<ul style="list-style-type: none"> Replace low-profile air cleaner element. 	Air Cleaner/Intake
<ul style="list-style-type: none"> Check fuel filters (tank outlet filter and in-line filter) clean or replace if needed (if equipped). 	Fuel System
<ul style="list-style-type: none"> Change oil in 6:1 Reduction System (CH245, CH255, CH270). 	Gear Reduction System

Every 300 Hours²

<ul style="list-style-type: none"> Check and adjust valve clearance when engine is cold. 	Reassembly
---	------------

Every 300 Hours³

<ul style="list-style-type: none"> Change engine oil (Xtended Life PRO 10W-50 oil only). 	Lubrication System
---	--------------------

Every 500 Hours or Annually¹ (whichever comes first)

<ul style="list-style-type: none"> Replace spark plug and set gap. 	Electrical System
---	-------------------

¹ Perform these procedures more frequently under severe, dusty, dirty conditions.

² Have a Rehlko authorized dealer perform this service.

³ Option only if using Xtended Life PRO 10W-50 oil.

REPAIRS/SERVICE PARTS

Rehlko genuine service parts can be purchased from Rehlko authorized dealers. To find a local Rehlko authorized dealer visit Engines.rehlko.com or call 1-800-544-2444 (U.S. and Canada).

Maintenance

OIL RECOMMENDATIONS

All-season Xtended Life PRO 10W-50 Synthetic Oil is the ideal oil for Rehlko engines. It is specifically formulated to extend the oil change interval to 300 Hours. Contact your Rehlko authorized dealer for availability.

300-Hour oil change intervals are exclusive to and only authorized on Rehlko engines that utilize the Xtended Life PRO 10W-50 Synthetic Oil. Alternative engine oils may be used with Rehlko engines but require 100-Hour oil change intervals for proper maintenance. Oil must be API (American Petroleum Institute) service class SJ or higher. Select viscosity based on air temperature at time of operation as shown below.

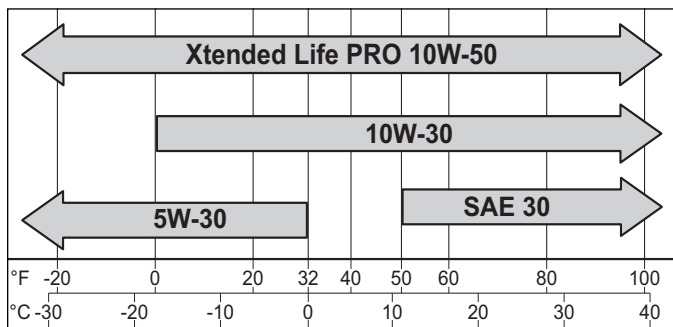

FUEL RECOMMENDATIONS

	WARNING
	Explosive Fuel can cause fires and severe burns. Do not fill fuel tank while engine is hot or running.
Gasoline is extremely flammable and its vapors can explode if ignited. Store gasoline only in approved containers, in well ventilated, unoccupied buildings, away from sparks or flames. Spilled fuel could ignite if it comes in contact with hot parts or sparks from ignition. Never use gasoline as a cleaning agent.	

NOTE: E15, E20 and E85 are NOT approved and should NOT be used; effects of old, stale or contaminated fuel are not warrantable.

Fuel must meet these requirements:

- Clean, fresh, unleaded gasoline.
- Octane rating of 87 (R+M)/2 or higher.
- Research Octane Number (RON) 90 octane minimum.
- Gasoline up to 10% ethyl alcohol, 90% unleaded is acceptable.
- Methyl Tertiary Butyl Ether (MTBE) and unleaded gasoline blend (max 15% MTBE by volume) are approved.
- Do not add oil to gasoline.
- Do not overfill fuel tank.
- Do not use gasoline older than 30 days.

STORAGE

If engine will be out of service for 2 months or more follow procedure below.

1. Add Xtended Life PRO 10W-50 Series fuel treatment or equivalent to fuel tank. Run engine 2-3 minutes to get stabilized fuel into fuel system (failures due to untreated fuel are not warrantable).
2. Change oil while engine is still warm from operation (NOT required if using Xtended Life PRO 10W-50 full-synthetic oil). Remove spark plug(s) and pour about 1 oz. of engine oil into cylinder(s). Replace spark plug(s) and crank engine slowly to distribute oil.
3. Disconnect negative (-) battery cable.
4. Store engine in a clean, dry place.

CH245/CH255 Engine Dimensions

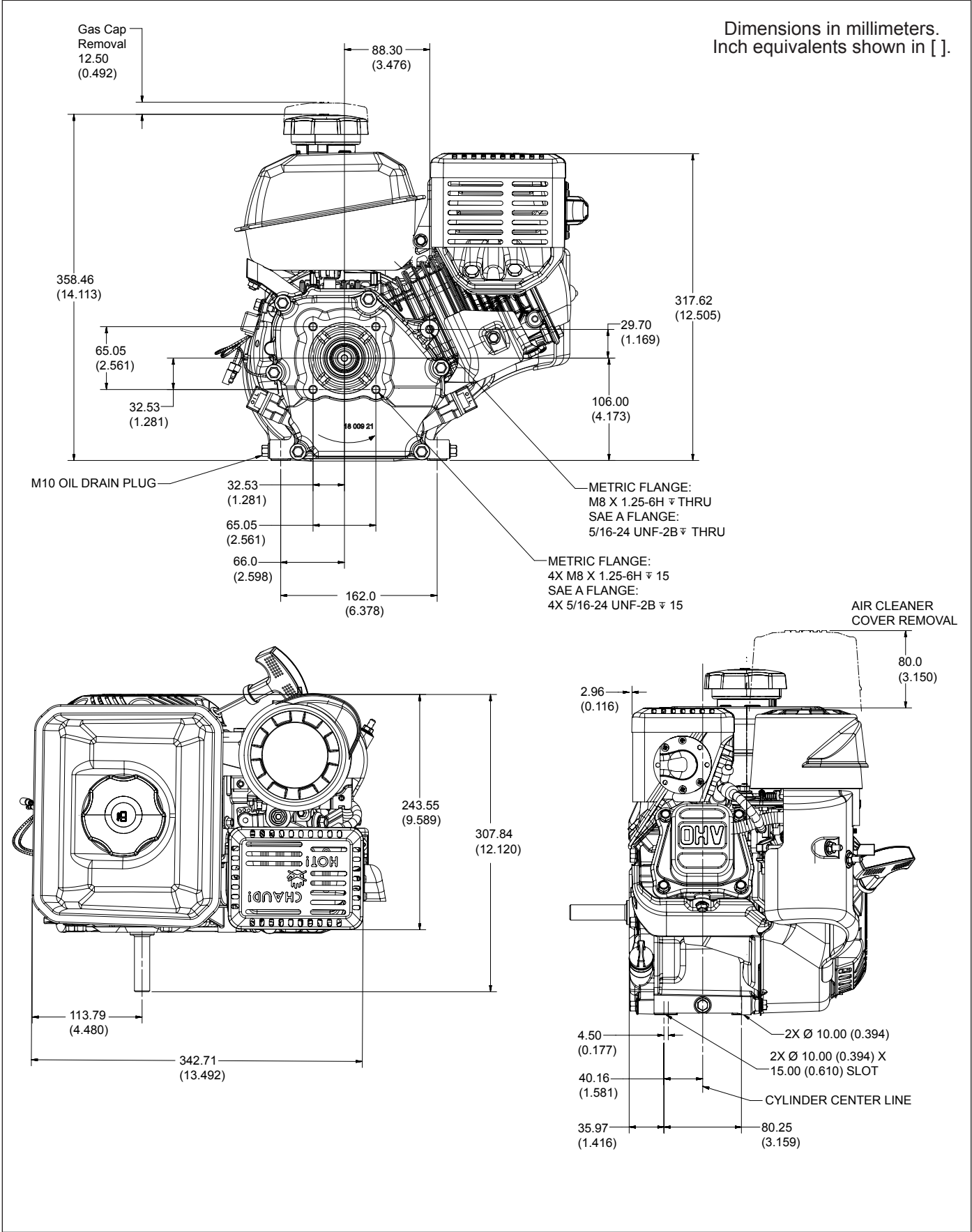

Specifications

CH260/CH270 Engine Dimensions

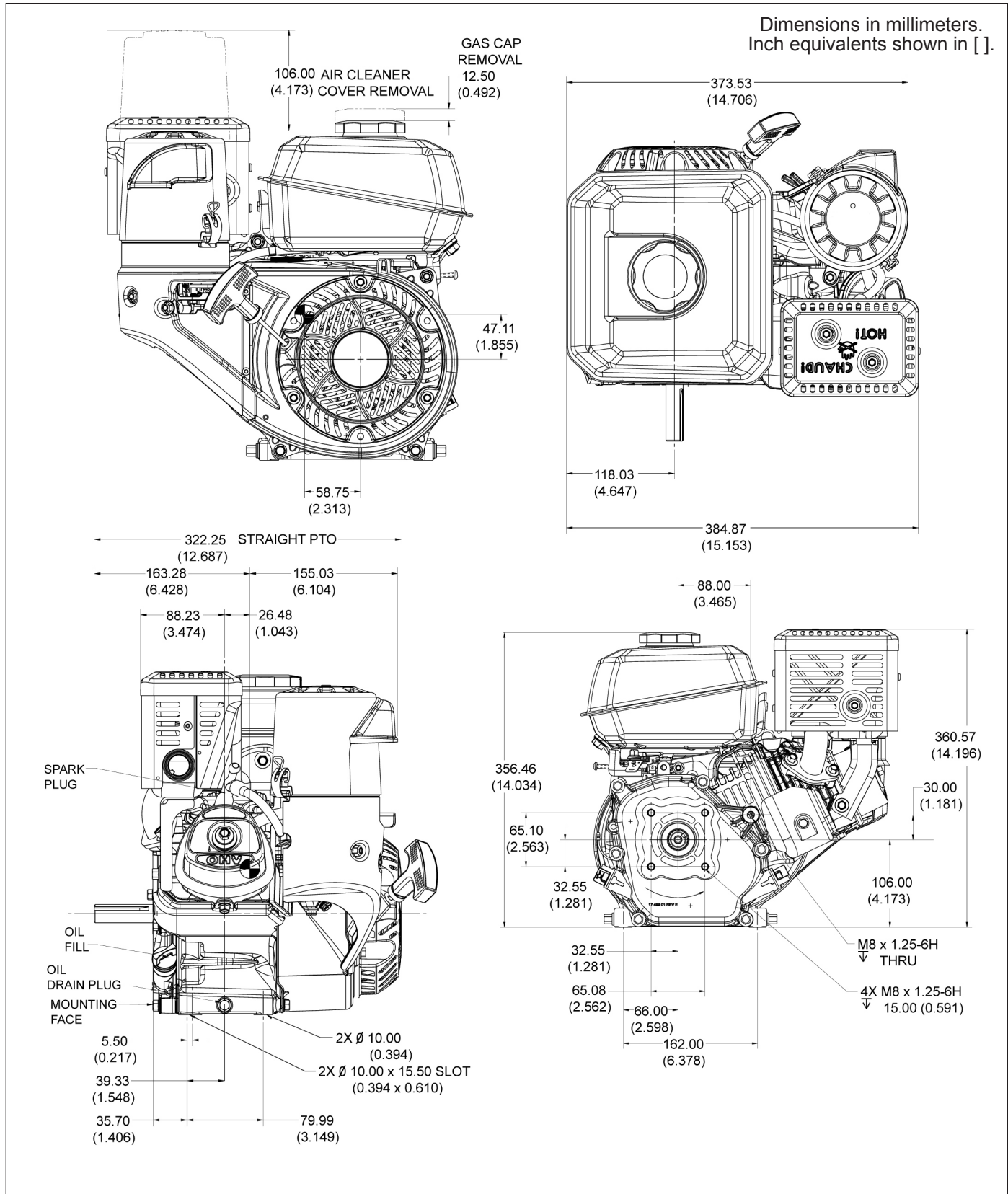

CH260/CH270 Engine Dimensions

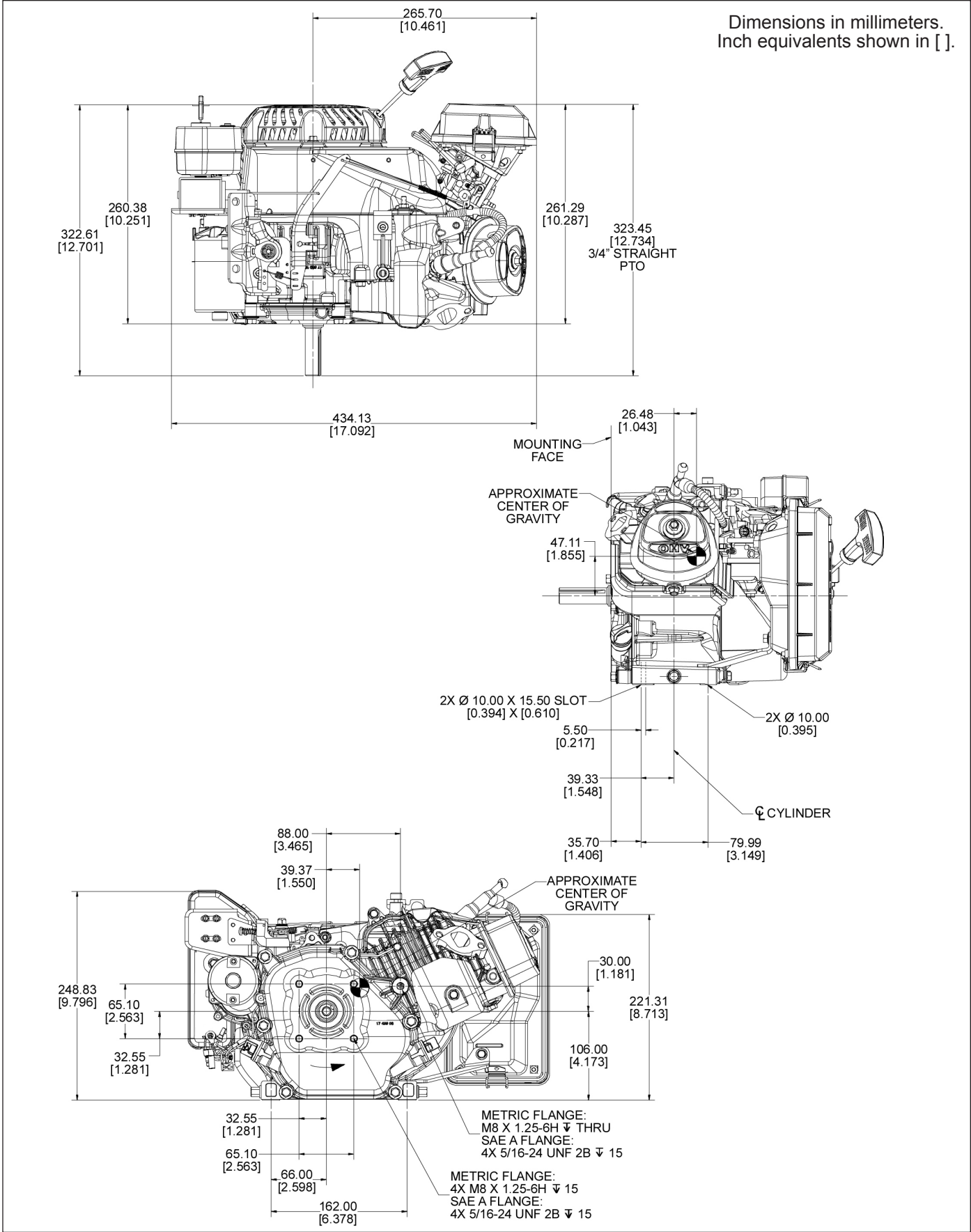

Specifications

CH395 Engine Dimensions

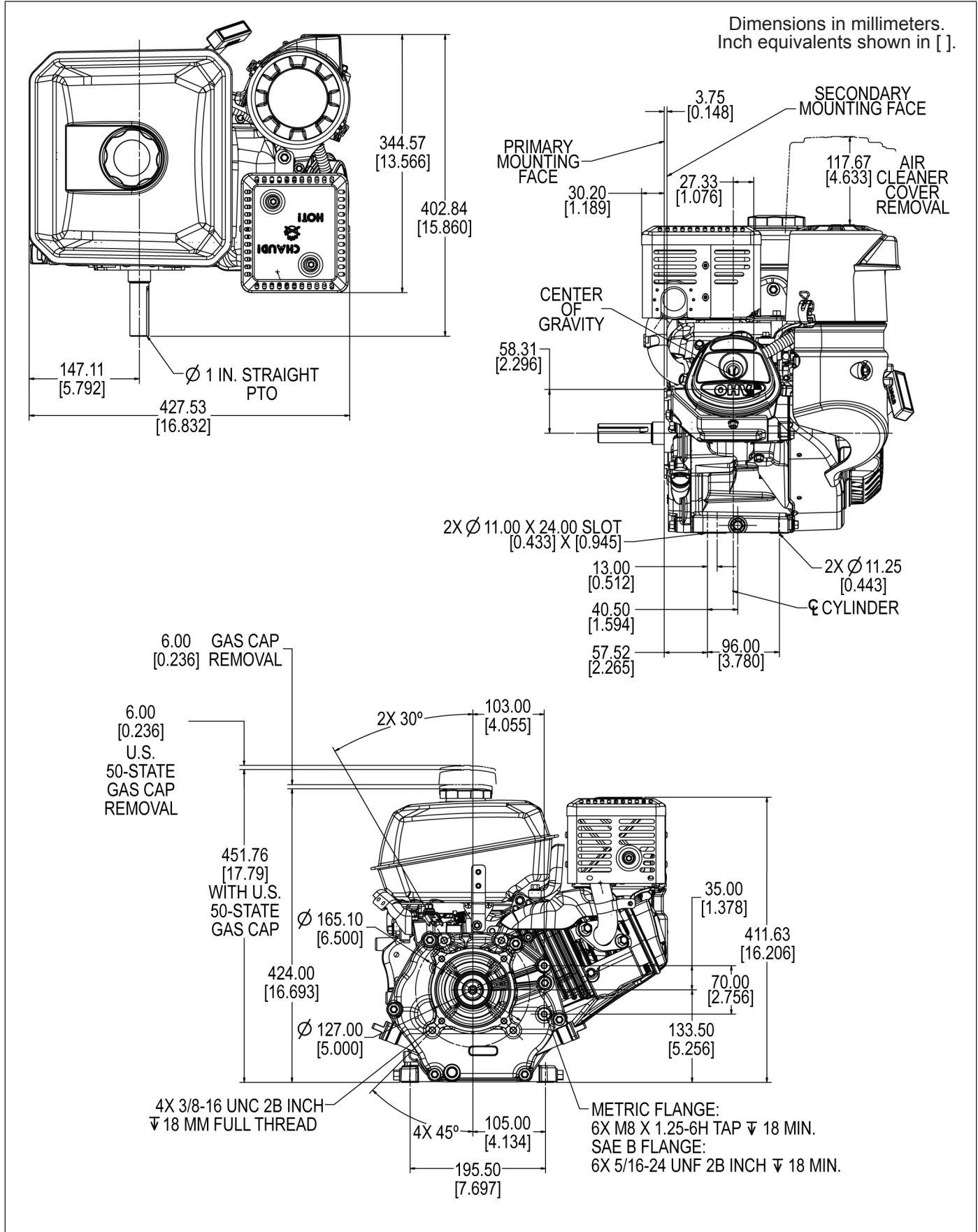

CH395 Engine Dimensions

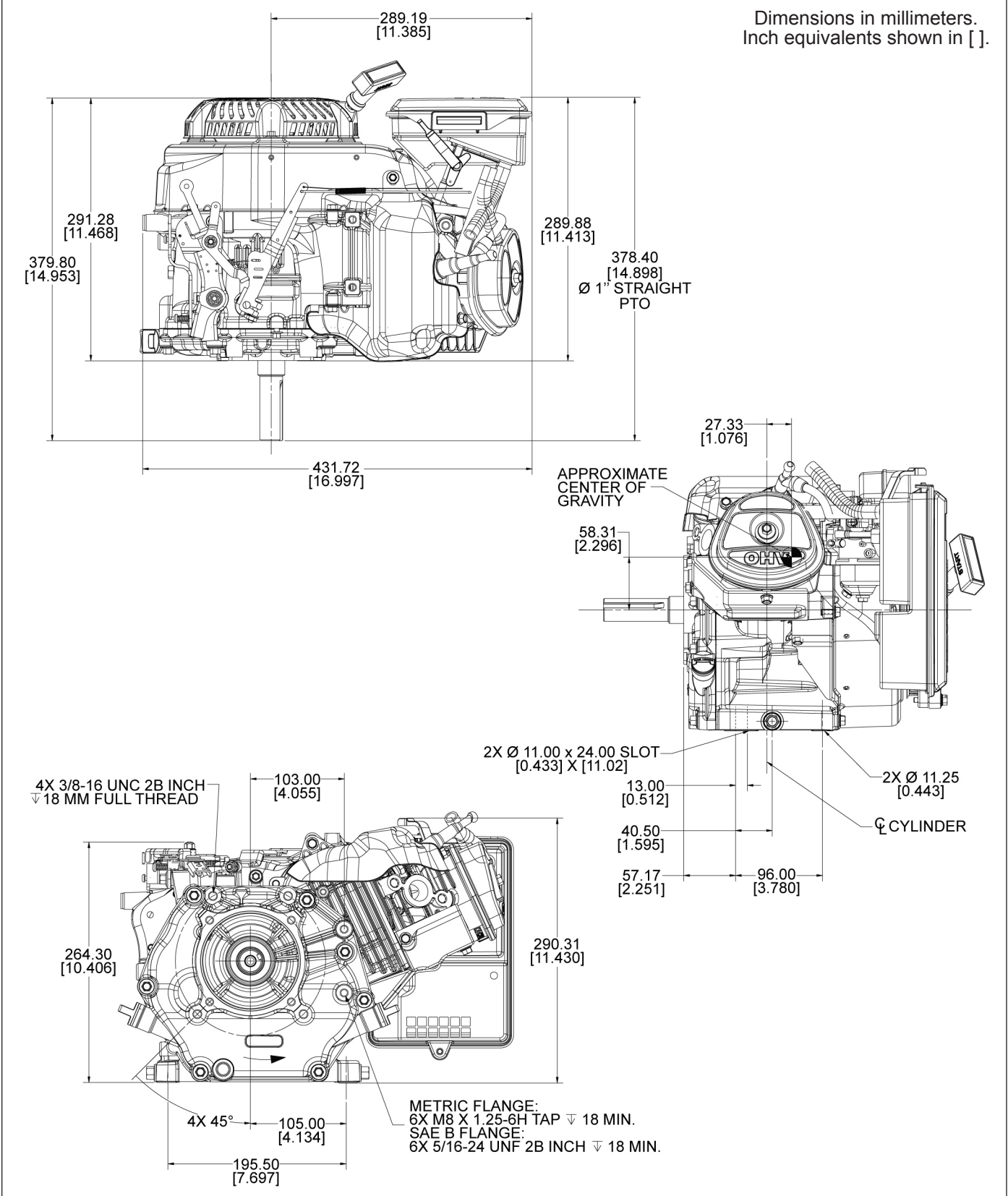

Specifications

CH440 Engine Dimensions

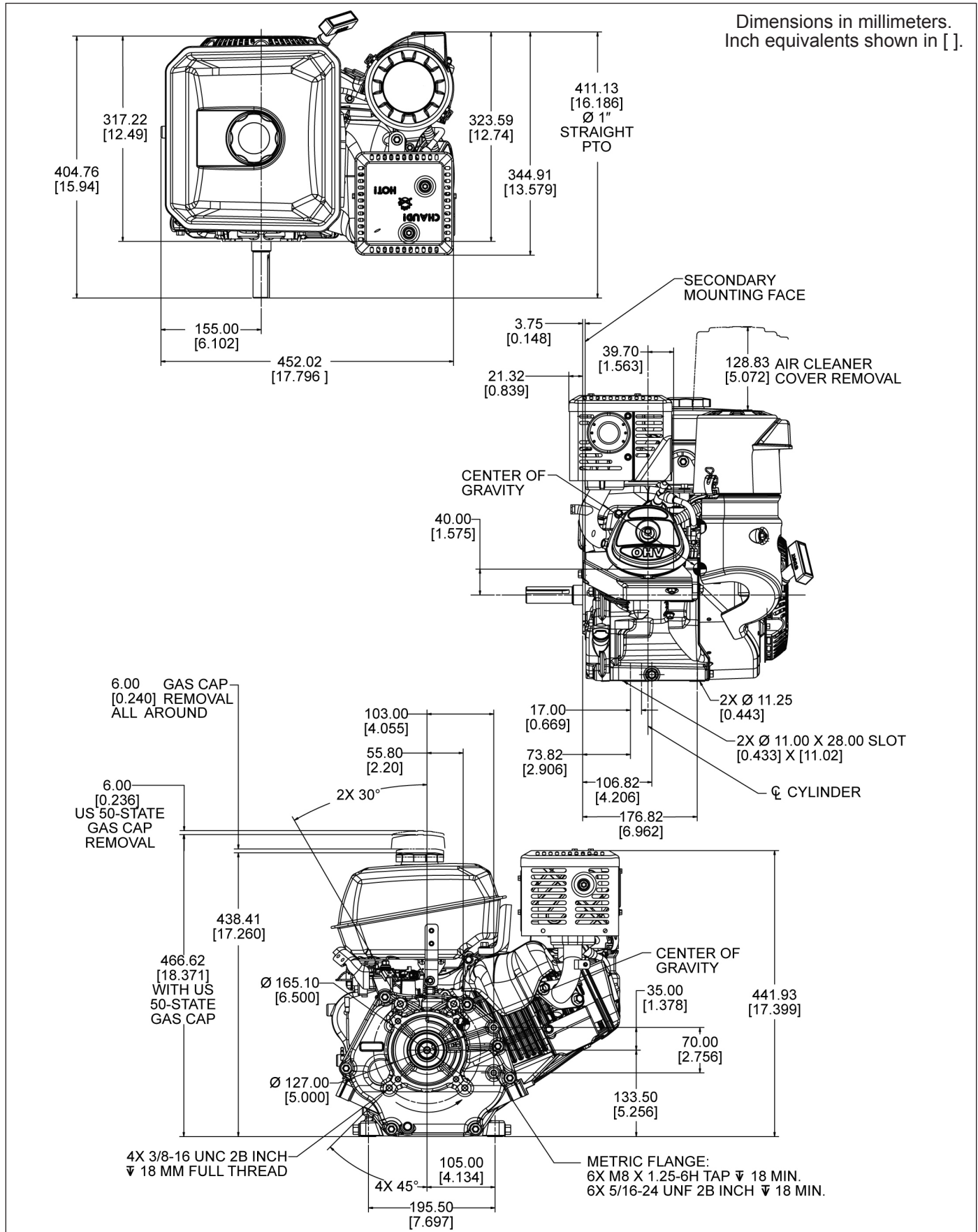

CH440 Engine Dimensions

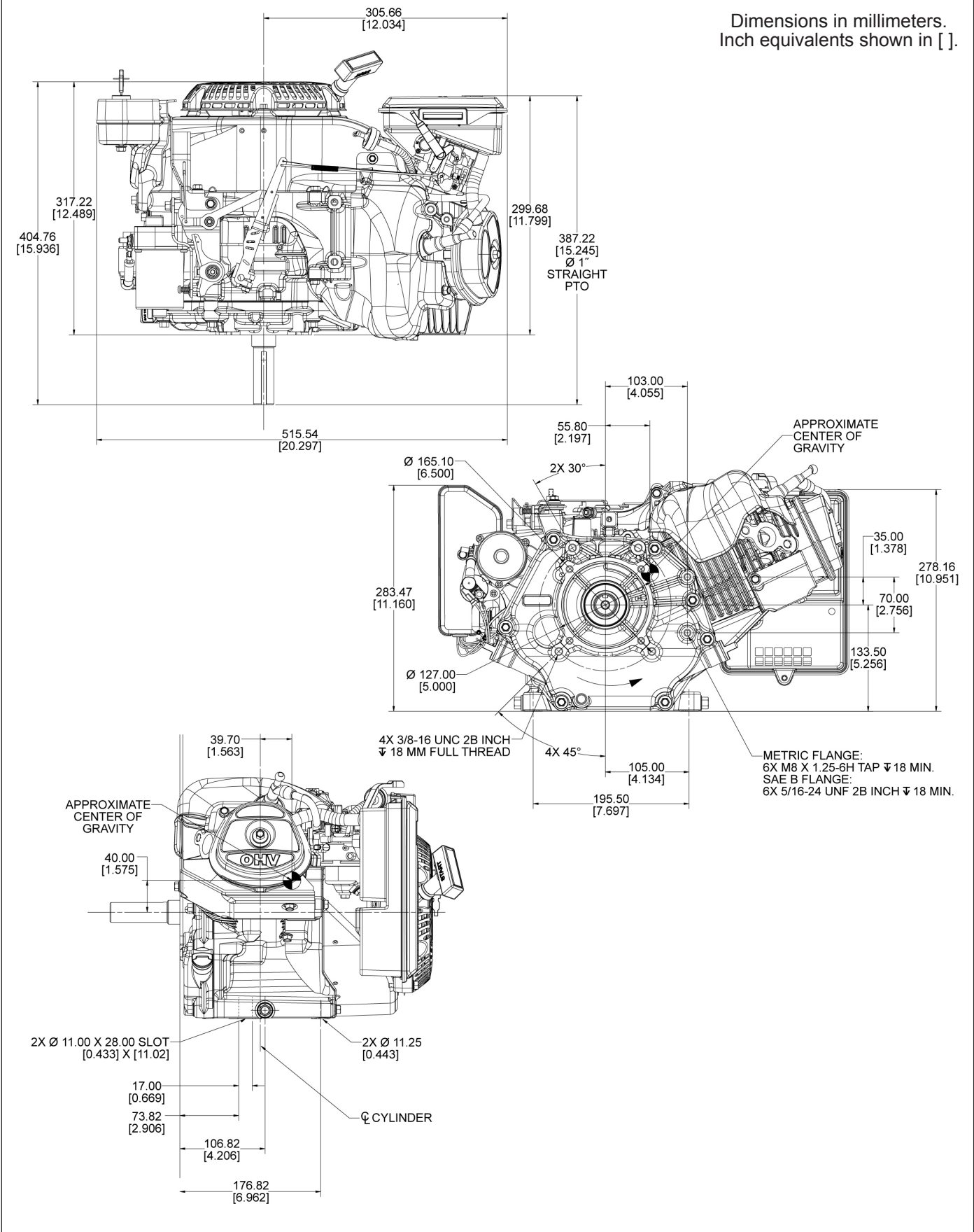

Specifications

ENGINE IDENTIFICATION NUMBERS

Rehiko engine identification numbers (model, specification and serial) should be referenced for efficient repair, ordering correct parts, and engine replacement.

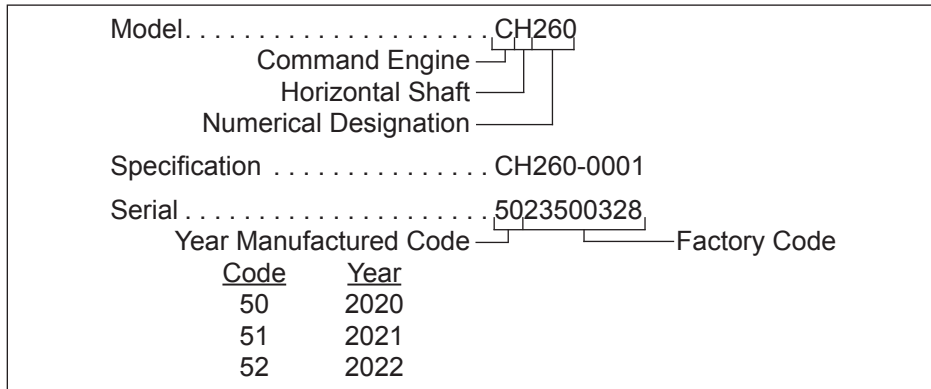

GENERAL SPECIFICATIONS^{4,7}

	CH245/CH255	CH260/CH270	CH395	CH440
Bore	68 mm (2.7 in.)	70 mm (2.8 in.)	78 mm (3.1 in.)	89 mm (3.5 in.)
Stroke	49 mm (1.9 in.)	54 mm (2.1 in.)	58 mm (2.3 in.)	69 mm (2.7 in.)
Displacement	177 cc (10.8 cu. in.)	208 cc (12.7 cu. in.)	277 cc (16.9 cu. in.)	429 cc (26.2 cu. in.)
Oil Capacity (refill)	0.6 L (0.63 U.S. qt.)	0.6 L (0.63 U.S. qt.)	1.1 L (1.16 U.S. qt.)	1.1 L (1.16 U.S. qt.)
Maximum Angle of Operation (@ full oil level) ⁵	25°			

TORQUE SPECIFICATIONS^{4,6}

	CH245/CH255	CH260/CH270	CH395	CH440
Air Cleaner				
Quad-Clean™ Air Cleaner Base Mounting Screw	---	8.0 N·m (71 in. lb.)		
Quad-Clean™ Air Cleaner Base Mounting Nut	8 N·m (71 in. lb.)	---		
Low-Profile Air Cleaner Base Mounting Screw	6.7 N·m (59 in. lb.)			

Blower Housing and Sheet Metal

M6 Screw	10 N·m (89 in. lb.)
M6 Nut	8.0 N·m (71 in. lb.)

Carburetor

Stud	10 N·m (89 in. lb.)
Primary Nut	8 N·m (71 in. lb.)
Intake Cover Nut	4 N·m (35 in. lb.)
Intake Cover Screw	1.3 N·m (12 in. lb.)
Fuel Shut-off Solenoid (if equipped)	7 N·m (62 in. lb.)
Solenoid Base Assembly Screw (if equipped)	1.5 N·m (13 in. lb.)

Connecting Rod

Cap Fastener (torque in increments)	12.4 N·m (111 in. lb.)	20 N·m (177 in. lb.)
-------------------------------------	------------------------	----------------------

⁴ Values are in Metric units. Values in parentheses are English equivalents.

⁵ Exceeding maximum angle of operation may cause engine damage from insufficient lubrication.

⁶ Lubricate threads with engine oil prior to assembly.

⁷ Any and all horsepower (hp) references by Rehiko are Certified Power Ratings and per SAE J1940 & J1995 hp standards. Details on Certified Power Ratings can be found at Engines.rehiko.com.

Specifications

TORQUE SPECIFICATIONS^{4,6}

CH245/CH255

CH260/CH270

CH395

CH440

Crankcase

Oil Drain Plug	18 N·m (13 ft. lb.)
Closure Plate Screw	24 N·m (212 in. lb.)

Cylinder Head

Fastener (torque in 2 increments)	First to 12 N·m (106 in. lb.) Finally to 24 N·m (212 in. lb.)	First to 18 N·m (159 in. lb.) Finally to 36 N·m (319 in. lb.)	First to 25 N·m (221 in. lb.) Finally to 57.5 N·m (509 in. lb.)
-----------------------------------	--	--	--

Electric Starter

Mounting Screw	24 N·m (212 in. lb.)
----------------	----------------------

Electric Starter Drive CH440 Type II Starter

Assembly Screw 5 mm	---	---	---	5.8 N·m (51 in. lb.)
Brush Lead Connector Wire Screw 4 mm	---	---	---	1.7 N·m (15 in. lb.)

Electric Starter Relay (Solenoid) CH395, CH440

Mounting Screw	---	---	3.2 N·m (28 in. lb.)
Nut	---	---	4.5 N·m (40 in. lb.)

Flywheel

Retaining Nut	74 N·m (655 in. lb.)	113 N·m (1000 in. lb.)
---------------	----------------------	------------------------

Fuel Tank

Mounting Nut	10 N·m (89 in. lb.)	24 N·m (212 in. lb.)
Mounting Screw	10 N·m (89 in. lb.)	24 N·m (212 in. lb.)
Inlet Fitting	1.5 N·m (13 in. lb.)	

Gear Reduction

M6 Screws	7.4 N·m (66 in. lb.)
M8 Screws	24.4 N·m (216 in. lb.)

Governor (Electronic)

Electronic Governor Control to Crankcase	---	24 N·m (212 in. lb.)
--	-----	----------------------

Governor (Mechanical)

Lever Nut	12 N·m (106 in. lb.)
Throttle Control Lever Nut	9 N·m (80 in. lb.)

Ignition

Spark Plug	27 N·m (20 ft. lb.)
Module Fastener	10 N·m (89 in. lb.)
Oil Sentry™ Float Switch Screw	8 N·m (71 in. lb.)
Oil Sentry™ Module Screw	3.5 N·m (31 in. lb.)
Oil Sentry™ Wire Lead Nut	10 N·m (89 in. lb.)
Stator Fastener (if equipped)	10 N·m (89 in. lb.)

⁴ Values are in Metric units. Values in parentheses are English equivalents.

⁶ Lubricate threads with engine oil prior to assembly.

Specifications

TORQUE SPECIFICATIONS^{4,6}

CH245/CH255 CH260/CH270

CH395

CH440

Muffler

Exhaust Screw M8 M10	24 N·m (212 in. lb.) ---	---	35 N·m (310 in. lb.)
Muffler Shield Screw M6	8 N·m (71 in. lb.)		
M4	2 N·m (18 in. lb.)	3.5 N·m (31 in. lb.)	
Spark Arrestor Screw M5	3.5 N·m (31 in. lb.)		
Deflector Screw	1.5 N·m (13 in. lb.)		
Pipe Protector Shield Screw	2.5 N·m (22 in. lb.)		

Retractable Starter

Cover Screw	5.4 N·m (48 in. lb.)
Center Screw	10 N·m (89 in. lb.)

Rocker Arm

Stud	13.6 N·m (120 in. lb.)
Pivot Jam Nut	10 N·m (89 in. lb.)

Valve Cover

Fastener	8 N·m (71 in. lb.)	10 N·m (89 in. lb.)
----------	--------------------	---------------------

CLEARANCE SPECIFICATIONS⁴

CH245/CH255

CH260/CH270

CH395

CH440

Camshaft

Running Clearance	0.016/0.052 mm (0.0006/0.0020 in.)	0.007/0.043 mm (0.0003/0.0017 in.)	0.016/0.052 mm (0.0006/0.0020 in.)	
Bore I.D. New	14.000/14.018 mm (0.5512/0.5519 in.)		16.000/16.018 mm (0.6299/0.6306 in.)	
Max. Wear Limit	14.018 mm (0.5519 in.)		16.068 mm (0.6326 in.)	
Camshaft Bearing Surface O.D. New	---	13.975 mm (0.5502 in.)	15.975 mm (0.6289 in.)	
Max. Wear Limit	---	13.90 mm (0.547 in.)	15.90 mm (0.626 in.)	
Cam Lobe Profile (minimum dimension, measured from base circle to top of lobe) Intake - New	27.608 mm (1.087 in.)	27.787 mm (1.094 in.)	32.408 mm (1.276 in.)	32.286 mm (1.271 in.)
Max. Wear Limit	27.354 mm (1.067 in.)	27.533 mm (1.084 in.)	32.154 mm (1.266 in.)	32.032 mm (1.261 in.)
Exhaust - New	27.770 mm (1.093 in.)	27.861 mm (1.097 in.)	32.12 mm (1.265 in.)	32.506 mm (1.280 in.)
Max. Wear Limit	27.516 mm (1.083 in.)	27.607 mm (1.087 in.)	31.866 mm (1.255 in.)	32.252 mm (1.270 in.)

⁴ Values are in Metric units. Values in parentheses are English equivalents.

⁶ Lubricate threads with engine oil prior to assembly.

Specifications

CLEARANCE SPECIFICATIONS⁴ CH245/CH255 CH260/CH270 CH395 CH440

Connecting Rod

Crankpin End I.D. @ 21°C (70°F) New	30.021/30.026 mm (1.1819/1.1823 in.)	30.020/30.030 mm (1.1819/1.1823 in.)	33.020/33.030 mm (1.3000/1.3004 in.)	37.020/37.030 mm (1.4575/1.4579 in.)
Max. Wear Limit	30.08 mm (1.184 in.)	30.106 mm (1.185 in.)	33.07 mm (1.302 in.)	37.08 mm (1.460 in.)

Connecting Rod-to-Crankpin Side Clearance

New	0.12/0.58 mm (0.0047/0.0228 in.)	0.12/0.58 mm (0.0047/0.0228 in.)	0.1/0.55 mm (0.0039/0.0216 in.)	0.23/0.43 mm (0.0091/0.0169 in.)
Max. Wear Limit	1.10 mm (0.043 in.)	1.10 mm (0.043 in.)	1.36 mm (0.054 in.)	1.06 mm (0.042 in.)
Connecting Rod-to-Piston Pin Running Clearance	0.01/0.027 mm (0.0004/0.0011 in.)	0.008/0.025 mm (0.0003/0.0010 in.)	0.006/0.028 mm (0.0002/0.0011 in.)	0.008/0.025 mm (0.0003/0.0010 in.)
Piston Pin End I.D. @ 21°C (70°F) New	18.010/18.015 mm (0.709/0.7093 in.)	18.006/18.017 mm (0.7089/0.7093 in.)		20.006/20.017 mm (0.7876/0.7881 in.)
Max. Wear Limit	18.08 mm (0.712 in.)	18.08 mm (0.712 in.)		20.03 mm (0.789 in.)

Crankcase

Governor Cross Shaft Bore I.D. New	6.000/6.024 mm (0.2362/0.2372 in.)	8.000/8.024 mm (0.3150/0.3159 in.)
Max. Wear Limit	6.037 mm (0.2377 in.)	8.075 mm (0.3179 in.)

Crankshaft

End Play (free)	0.025/0.703 mm (0.0010/0.028 in.)	0.0508/0.254 mm (0.002/0.010 in.)		
Ball Bearing Internal Clearance	0.003/0.025 mm (0.0001/0.0010 in.)		0.005/0.020 mm (0.0002/0.0008 in.)	0.006/0.020 mm (0.0002/0.0008 in.)
Crankshaft O.D. (new) PTO end	24.975/24.989 mm (0.9833/0.9838 in.)		29.975/29.989 mm (1.1801/1.1807 in.)	34.975/34.989 mm (1.3770/1.3775 in.)
Flywheel end			30.014/30.027 mm (1.1817/1.1822 in.)	35.009/35.027 mm (1.3783/1.3790 in.)
Connecting Rod Journal O.D. New	29.970-29.980 mm (1.1799-1.1803 in.)	29.975/29.985 mm (1.1801/1.1805 in.)	32.975/32.985 mm (1.2982/1.2986 in.)	36.975/36.985 mm (1.4557/1.4561 in.)
Max. Wear Limit	29.95 mm (0.9823 in.)	29.924 mm (1.1781 in.)	32.92 mm (1.2961 in.)	36.92 mm (1.4535 in.)
Max. Taper Max. Out-of-Round	0.025 mm (0.0010 in.)	2.5 microns (0.0001 in.) 12.7 microns (0.0005 in.)		
Width	25.02/25.08 mm (0.9850/0.9874 in.)		30.30/30.36 mm (1.1930/1.1953 in.)	28.30/28.36 mm (1.1142/1.1165 in.)
Runout (either end)	0.025 mm (0.001 in.)			
Main Bearing I.D. (Crankcase/ Closure Plate) New (installed)	24.994/25.000 mm (0.9840/0.9842 in.)	24.992/25.000 mm (0.9839/0.9842 in.)	29.990/30.000 mm (1.1807/1.1811 in.)	34.988/35.000 mm (1.3775/1.3779 in.)

⁴ Values are in Metric units. Values in parentheses are English equivalents.

Specifications

CLEARANCE SPECIFICATIONS ⁴	CH245/CH255	CH260/CH270	CH395	CH440
---------------------------------------	-------------	-------------	-------	-------

Cylinder Bore

Bore I.D. New	68.0125/68.0275 mm (2.6777/2.6782 in.)	70.020/70.035 mm (2.7570/2.7573 in.)	78.000/78.015 mm (3.0709/3.0714 in.)	89.000/89.015 mm (3.5039/3.5045 in.)
Max. Wear Limit	68.200 mm (2.685 in.)	70.200 mm (2.764 in.)	78.185 mm (3.0781 in.)	89.185 mm (3.5112 in.)
Max. Out-of-Round Max. Taper	12.7 microns (0.0005 in.) 12.7 microns (0.0005 in.)			

Cylinder Head

Max. Out-of-Flatness	0.10 mm (0.0039 in.)	0.08 mm (0.003 in.)	0.1 mm (0.0039 in.)	
----------------------	-------------------------	------------------------	---------------------	--

Governor (Mechanical)

Governor Cross Shaft -to- Crankcase Running Clearance	0.013/0.075 mm (0.0005/0.0029 in.)	0.020/0.069 mm (0.0008/0.0027 in.)		
Governor Cross Shaft O.D. New	5.955/5.980 mm (0.2344/0.2354 in.)		7.955/7.980 mm (0.3132/0.3142 in.)	
Max. Wear Limit	5.85 mm (0.2303 in.)	5.942 mm (0.2339 in.)	7.900 mm (0.3110 in.)	
Governor Gear Shaft -to-Governor Gear Running Clearance	0.09/0.19 mm (0.0035/0.0074 in.)	0.022/0.134 mm (0.0009/0.0053 in.)		
Governor Gear Shaft O.D. New Max. Wear Limit	6.028/6.043 mm (0.2373/0.2379 in.) 6.018 mm (0.2369 in.)	6.016/6.028 mm (0.2368/0.2373 in.) 6.003 mm (0.2363 in.)		

Ignition

Spark Plug Gap	0.76 mm (0.030 in.)			
Module Air Gap	0.254 mm (0.010 in.)			

Piston, Piston Rings, and Piston Pin

Piston-to-Piston Pin Running Clearance	0.009/0.016 mm (0.0003/0.0006 in.)		0.002/0.016 mm (0.0001/0.0006 in.)	
Piston Pin Bore I.D. New	18.004/18.005 mm (0.7088/0.7090 in.)	18.000/18.008 mm (0.7087/0.7090 in.)		20.000/20.008 mm (0.7874/0.7877 in.)
Max. Wear Limit	18.05 mm (0.7106 in.)			20.05 mm (0.7894 in.)
Piston Pin O.D. New	17.992/17.995 mm (0.7083/0.7084 in.)	17.992/17.998 mm (0.7083/0.7084 in.)		19.992/19.998 mm (0.7871/0.7873 in.)
Max. Wear Limit	17.95 mm (0.7067 in.)			19.95 mm (0.7854 in.)
Top and Center Compression Ring Side Clearance New Bore	0.04 mm (0.002 in.)		0.07 mm (0.003 in.)	0.045 mm (0.0018 in.)
Used Bore (Max.)	0.15 mm (0.006 in.)		0.11 mm (0.004 in.)	0.10 mm (0.004 in.)
Top Compression Ring End Gap New Bore	0.325/0.400 mm (0.013/0.016 in.)		0.250/0.400 mm (0.010/0.016 in.)	
Used Bore (Max.)	1.00 mm (0.039 in.)			
Center Compression Ring End Gap New Bore	0.325/0.400 mm (0.013/0.016 in.)		0.650/0.800 mm (0.026/0.032 in.)	0.640/0.800 mm (0.025/0.032 in.)
Used Bore (Max.)	1.00 mm (0.039 in.)		1.50 mm (0.059 in.)	

⁴ Values are in Metric units. Values in parentheses are English equivalents.

CLEARANCE SPECIFICATIONS ⁴	CH245/CH255	CH260/CH270	CH395	CH440
---------------------------------------	-------------	-------------	-------	-------

Piston, Piston Rings, and Piston Pin (continued)

Oil Control Ring-to-Groove Side Clearance	0.05/0.19 mm (0.0019/0.0075 in.)			0.09/0.15 mm (0.0035/0.0059 in.)
Piston Thrust Face O.D. New	67.975/67.985 mm (2.6762/2.6766 in.) ⁸	69.975/69.995 mm (2.755/2.756 in.) ⁹	77.955/77.975 mm (3.069/3.070 in.) ¹⁰	88.955/88.975 mm (3.502/3.503 in.) ¹¹
Max. Wear Limit	67.85 mm (2.6712 in.)	69.82 mm (2.749 in.)	77.82 mm (3.064 in.)	88.82 mm (3.497 in.)
Piston Thrust Face-to-Cylinder Bore Running Clearance	0.057/0.075 mm (0.0022/0.0029 in.) ⁸	0.057/0.075 mm (0.002/0.003 in.) ⁹	0.033/0.067 mm (0.001/0.003 in.) ¹⁰	0.025/0.060 mm (0.001/0.002 in.) ¹¹

Valves and Valve Tappets

Intake and Exhaust Valve Lash	0.0762/0.127 mm (0.003/0.005 in.)			
Intake Valve Stem-to-Valve Guide Running Clearance	0.020/0.044 mm (0.008/0.0017 in.)	0.038/0.065 mm (0.0015/0.0026 in.)	0.025/0.055 mm (0.0010/0.0022 in.)	
Exhaust Valve Stem-to-Valve Guide Running Clearance	0.030/0.054 mm (0.0011/0.0021 in.)	0.085/0.112 mm (0.0033/0.0044 in.)	0.040/0.07 mm (0.0016/0.0028 in.)	
Intake Valve Stem O.D. New	5.480 mm (0.2157 in.)	5.50 mm (0.217 in.)	6.57 mm (0.259 in.)	
Max. Wear Limit	5.320 mm (0.2094 in.)	5.34 mm (0.210 in.)	6.40 mm (0.252 in.)	
Exhaust Valve Stem O.D. New	5.47 mm (0.2153 in.)	5.438 mm (0.214 in.)	6.55 mm (0.258 in.)	
Max. Wear Limit	5.305 mm (0.2088 in.)	5.28 mm (0.208 in.)	6.41 mm (0.252 in.)	
Intake Valve Stem to Guide New	0.024/0.039 mm (0.0009/0.0015 in.)		0.025/0.055 mm (0.0010/0.0022 in.)	
Max. Wear Limit	0.10 mm (0.0039 in.)		0.13 mm (0.0051 in.)	0.14 mm (0.0055 in.)
Exhaust Valve Stem to Guide New	0.098/0.112 mm (0.0038/0.0044 in.)		0.040/0.070 mm (0.0016/0.0028 in.)	
Max. Wear Limit	0.12 mm (0.0047 in.)		0.10 mm (0.0039 in.)	0.11 mm (0.0043 in.)
Valve Guide Reamer Size Standard Intake	5.506 mm (0.2168 in.)	5.524 mm (0.2175 in.)	6.608 mm (0.2602 in.)	
Standard Exhaust	5.506 mm (0.2168 in.)	5.536 mm (0.2179 in.)	6.608 mm (0.2602 in.)	
Valve Seat Width	0.800/2.00 mm (0.0315/0.787 in.)	0.80 mm (0.0315 in.)	1.10 mm (0.0433 in.)	1.20 mm (0.0472 in.)
Nominal Valve Face Angle	30°, 45°, 60°		45°	

⁴ Values are in Metric units. Values in parentheses are English equivalents.

⁸ Measure 15 mm (0.5905 in.) above bottom of piston skirt at right angles to piston pin.



⁹ Measure 21.8-22.2 mm (0.8583-0.8740 in.) above bottom of piston skirt at right angles to piston pin.

¹⁰ Measure 17.8-18.2 mm (0.7008-0.7165 in.) above bottom of piston skirt at right angles to piston pin.





¹¹ Measure 29.8-30.2 mm (1.1732-1.1890 in.) above bottom of piston skirt at right angles to piston pin.

Specifications

GENERAL TORQUE VALUES

English Fastener Torque Recommendations for Standard Applications				
Bolts, Screws, Nuts and Fasteners Assembled Into Cast Iron or Steel				Grade 2 or 5 Fasteners Into Aluminum
Size	 Grade 2	 Grade 5	 Grade 8	
Tightening Torque: N·m (in. lb.) ± 20%				
8-32	2.3 (20)	2.8 (25)	—	2.3 (20)
10-24	3.6 (32)	4.5 (40)	—	3.6 (32)
10-32	3.6 (32)	4.5 (40)	—	—
1/4-20	7.9 (70)	13.0 (115)	18.7 (165)	7.9 (70)
1/4-28	9.6 (85)	15.8 (140)	22.6 (200)	—
5/16-18	17.0 (150)	28.3 (250)	39.6 (350)	17.0 (150)
5/16-24	18.7 (165)	30.5 (270)	—	—
3/8-16	29.4 (260)	—	—	—
3/8-24	33.9 (300)	—	—	—

Tightening Torque: N·m (ft. lb.) ± 20%				
5/16-24	—	—	40.7 (30)	—
3/8-16	—	47.5 (35)	67.8 (50)	—
3/8-24	—	54.2 (40)	81.4 (60)	—
7/16-14	47.5 (35)	74.6 (55)	108.5 (80)	—
7/16-20	61.0 (45)	101.7 (75)	142.5 (105)	—
1/2-13	67.8 (50)	108.5 (80)	155.9 (115)	—
1/2-20	94.9 (70)	142.4 (105)	223.7 (165)	—
9/16-12	101.7 (75)	169.5 (125)	237.3 (175)	—
9/16-18	135.6 (100)	223.7 (165)	311.9 (230)	—
5/8-11	149.5 (110)	244.1 (180)	352.6 (260)	—
5/8-18	189.8 (140)	311.9 (230)	447.5 (330)	—
3/4-10	199.3 (147)	332.2 (245)	474.6 (350)	—
3/4-16	271.2 (200)	440.7 (325)	637.3 (470)	—

Metric Fastener Torque Recommendations for Standard Applications						
Size	Property Class					Noncritical Fasteners Into Aluminum
	 4.8	 5.8	 8.8	 10.9	 12.9	
Tightening Torque: N·m (in. lb.) ± 10%						
M4	1.2 (11)	1.7 (15)	2.9 (26)	4.1 (36)	5.0 (44)	2.0 (18)
M5	2.5 (22)	3.2 (28)	5.8 (51)	8.1 (72)	9.7 (86)	4.0 (35)
M6	4.3 (38)	5.7 (50)	9.9 (88)	14.0 (124)	16.5 (146)	6.8 (60)
M8	10.5 (93)	13.6 (120)	24.4 (216)	33.9 (300)	40.7 (360)	17.0 (150)
Tightening Torque: N·m (ft. lb.) ± 10%						
M10	21.7 (16)	27.1 (20)	47.5 (35)	66.4 (49)	81.4 (60)	33.9 (25)
M12	36.6 (27)	47.5 (35)	82.7 (61)	116.6 (86)	139.7 (103)	61.0 (45)
M14	58.3 (43)	76.4 (56)	131.5 (97)	184.4 (136)	219.7 (162)	94.9 (70)

Torque Conversions	
N·m = in. lb. x 0.113	in. lb. = N·m x 8.85
N·m = ft. lb. x 1.356	ft. lb. = N·m x 0.737

Certain quality tools are designed to help you perform specific disassembly, repair, and reassembly procedures. By using these tools, you can properly service engines easier, faster, and safer! In addition, you'll increase your service capabilities and customer satisfaction by decreasing engine downtime.

Here is a list of tools and their source.

NOTE: Not all tools listed are required to service this engine.

SEPARATE TOOL SUPPLIERS

Rehiko Tools
Contact your local Rehiko source of supply.

SE Tools
415 Howard St.
Lapeer, MI 48446
Phone 810-664-2981
Toll Free 800-664-2981
Fax 810-664-8181

Design Technology Inc.
768 Burr Oak Drive
Westmont, IL 60559
Phone 630-920-1300
Fax 630-920-0011

TOOLS

Description	Source/Part No.
Alcohol Content Tester For testing alcohol content (%) in reformulated/oxygenated fuels.	Rehiko 25 455 11-S
Camshaft Endplay Plate For checking camshaft endplay.	SE Tools KLR-82405
Camshaft Seal Protector (Aegis) For protecting seal during camshaft installation.	SE Tools KLR-82417
Dual Gauge Cylinder Leakdown Tester For checking combustion retention and if cylinder, piston, rings, or valves are worn. Individual component available: Adapter 12 mm x 14 mm (Required for leakdown test on XT-6 engines)	Rehiko 25 761 46-S Design Technology Inc. DTI-731-03
Dealer Tool Kit Complete kit of Rehiko required tools. Components of 25 761 39-S Ignition System Tester Dual Gauge Cylinder Leakdown Test Tool Oil Pressure Test Kit Digital Vacuum/Pressure Tester	Rehiko 25 761 39-S Rehiko 25 455 01-S Rehiko 25 761 46-S Rehiko 25 761 06-S Rehiko 25 455 22-S
Digital Vacuum/Pressure Tester For checking crankcase vacuum. Individual component available: Rubber Adapter Plug	Rehiko 25 455 22-S Design Technology Inc. DTI-721-10
EFI Service Kit For troubleshooting and setting up an EFI engine. Components of 24 761 01-S Fuel Pressure Tester Noid Light 90° Adapter Code Plug, Red Wire Code Plug, Blue Wire Code Plug, Yellow Wire Can Bus Reset Tool, Green Wire Shrader Valve Adapter Hose Wire Probe Set (2 pieces regular wire with clip; 1 piece fused wire) Hose Removal Tool, Dual Size/End (also sold as individual Rehiko tool) K-Line Adapter Jumper Lead Wiring Harness	Rehiko 24 761 01-S Design Technology Inc. DTI-019 DTI-021 DTI-023 DTI-027 DTI-029 DTI-028 DTI-030 DTI-037 DTI-031 DTI-033 Rehiko 25 176 23-S
Diagnostic System (KDS) Gen 2 For Laptop or Desktop PC. Components of 25 761 50-S Engine Communication Module 7 Pin to DB9 Cable USB Module to PC Cable 7 Pin to 4 Pin Adapter	Rehiko 25 761 50-S Rehiko 25 761 47-S Rehiko 25 761 48-S Rehiko 25 761 49-S Rehiko 25 761 53-S
Mobile KDS (Wireless) Module For mobile Android or iOS EFI diagnostics. Individual component available: Wireless Diagnostic System Interface Cable	Rehiko 25 761 45-S Rehiko 25 761 44-S

Tools and Aids

TOOLS

Description	Source/Part No.
Flywheel Puller For properly removing flywheel from engine.	SE Tools KLR-82408
Flywheel Anchor Bolts, Washers, Nuts Tool Used with Flywheel Puller for properly removing flywheel from 5400 Series engine.	Rehiko 25 086 753-S
Hose Removal Tool, Dual Size/End (also available in EFI Service Kit) Used to properly remove fuel hose from engine components.	Rehiko 25 455 20-S
Ignition System Tester For testing output on all systems, including CD.	Rehiko 25 455 01-S
Inductive Tachometer (Digital) For checking operating speed (RPM) of an engine.	Design Technology Inc. DTI-110
Oil Pressure Test Kit For testing/verifying oil pressure on pressure lubricated engines.	Rehiko 25 761 06-S
Rectifier-Regulator Tester (120 volt current) Rectifier-Regulator Tester (240 volt current) For testing rectifier-regulators. Components of 25 761 20-S and 25 761 41-S CS-PRO Regulator Test Harness Special Regulator Test Harness with Diode	Rehiko 25 761 20-S Rehiko 25 761 41-S Design Technology Inc. DTI-031R DTI-033R
Spark Advance Module (SAM) Tester For testing SAM (ASAM and DSAM) on engines with SMART-SPARK™.	Rehiko 25 761 40-S
Starter Servicing Kit (All Starters) For removing and reinstalling drive retaining rings and brushes. Individual component available: Starter Brush Holding Tool (Solenoid Shift)	SE Tools KLR-82411 SE Tools KLR-82416
Stepper Motor Controller Tool For testing operation of stepper motor/Digital Linear Actuator (DLA).	Rehiko 25 455 21-S
Jumper Lead Tool For use with Stepper Motor Controller Tool to test rotary stepper motor.	Rehiko 25 518 43-S
Triad/OHC Timing Tool Set For holding cam gears and crankshaft in timed position while installing timing belt.	Rehiko 28 761 01-S
Valve Guide Reamer (K and M Series) For properly sizing valve guides after installation.	Design Technology Inc. DTI-K828
Valve Guide Reamer O.S. (Command Series) For reaming worn valve guides to accept replacement oversize valves. Can be used in low-speed drill press or with handle below for hand reaming.	Rehiko 25 455 12-S
Reamer Handle For hand reaming using Rehiko 25 455 12-S reamer.	Design Technology Inc. DTI-K830

AIDS

Description	Source/Part No.
Camshaft Lubricant (Valspar ZZ613)	Rehiko 25 357 14-S
Dielectric Grease (GE/Novaguard G661)	Rehiko 25 357 11-S
Dielectric Grease	Loctite® 51360
Rehiko Electric Starter Drive Lubricant (Inertia Drive)	Rehiko 52 357 01-S
Rehiko Electric Starter Drive Lubricant (Solenoid Shift)	Rehiko 52 357 02-S
RTV Silicone Sealant Loctite® 5900® Heavy Body in 4 oz. aerosol dispenser. Only oxime-based, oil resistant RTV sealants, such as those listed, are approved for use. Permatex® the Right Stuff® 1 Minute Gasket™ or Loctite® Nos. 5900® or 5910® are recommended for best sealing characteristics. When Permatex® Ultra Grey® is to be used, this will be stated in Reassembly section.	Rehiko 25 597 07-S Loctite® 5910® Loctite® Ultra Black 598™ Loctite® Ultra Blue 587™ Loctite® Ultra Copper 5920™ Permatex® the Right Stuff® 1 Minute Gasket™
Spline Drive Lubricant	Rehiko 25 357 12-S

FLYWHEEL HOLDING TOOL

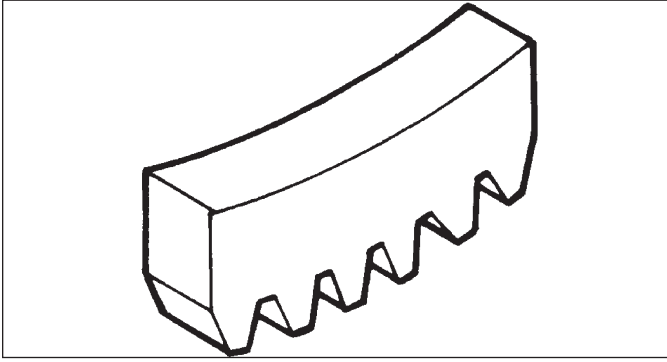

A flywheel holding tool can be made out of an old junk flywheel ring gear and used in place of a strap wrench.

1. Using an abrasive cut-off wheel, cut out a six tooth segment of ring gear as shown.
2. Grind off any burrs or sharp edges.
3. Invert segment and place it between ignition bosses on crankcase so tool teeth engage flywheel ring gear teeth. Bosses will lock tool and flywheel in position for loosening, tightening, or removing with a puller.

ROCKER ARM/CRANKSHAFT TOOL

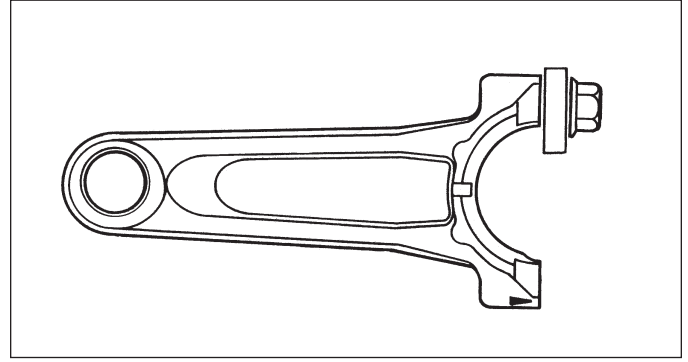

A spanner wrench to lift rocker arms or turn crankshaft may be made out of an old junk connecting rod.

1. Find a used connecting rod from a 10 HP or larger engine. Remove and discard rod cap.
2. Remove studs of a Posi-Lock rod or grind off aligning steps of a Command rod, so joint surface is flat.
3. Find a 1 in. long capscrew with correct thread size to match threads in connecting rod.
4. Use a flat washer with correct I.D. to slip on capscrew and approximately 1 in. O.D. Assemble capscrew and washer to joint surface of rod.

Troubleshooting

TROUBLESHOOTING GUIDE

When troubles occur, be sure to check simple causes which, at first, may seem too obvious to be considered. For example, a starting problem could be caused by an empty fuel tank.

Some general common causes of engine troubles are listed below and vary by engine specification. Use these to locate causing factors.

Engine Cranks But Will Not Start

- Battery connected backwards.
- Blown fuse.
- Carburetor solenoid malfunction.
- Choke not closing.
- Clogged fuel line or fuel filter.
- Diode in wiring harness failed in open circuit mode.
- Empty fuel tank.
- Faulty spark plug.
- Fuel pump malfunction-vacuum hose clogged or leaking.
- Fuel shut-off valve closed.
- Ignition module faulty or improperly gapped.
- Interlock switch is engaged or faulty.
- Key switch or kill switch in OFF position.
- Low oil level.
- Quality of fuel (dirt, water, stale, mixture).
- Spark plug lead disconnected.

Engine Starts But Does Not Keep Running

- Faulty carburetor.
- Faulty cylinder head gasket.
- Faulty or misadjusted choke or throttle controls.
- Fuel pump malfunction-vacuum hose clogged or leaking.
- Intake system leak.
- Loose wires or connections that intermittently ground ignition kill circuit.
- Quality of fuel (dirt, water, stale, mixture).
- Restricted fuel tank cap vent.

Engine Starts Hard

- Clogged fuel line or fuel filter.
- Engine overheated.
- Faulty ACR mechanism.
- Faulty or misadjusted choke or throttle controls.
- Faulty spark plug.
- Flywheel key sheared.
- Fuel pump malfunction-vacuum hose clogged or leaking.
- Interlock switch is engaged or faulty.
- Loose wires or connections that intermittently ground ignition kill circuit.
- Low compression.
- Quality of fuel (dirt, water, stale, mixture).
- Weak spark.

Engine Will Not Crank

- Battery is discharged.
- Faulty electric starter or solenoid.
- Faulty key switch or ignition switch.
- Interlock switch is engaged or faulty.
- Loose wires or connections that intermittently ground ignition kill circuit.
- Pawls not engaging in drive cup.
- Seized internal engine components.

Engine Runs But Misses

- Carburetor malfunction.
- Engine overheated.
- Faulty spark plug.
- Ignition module faulty or improperly gapped.
- Interlock switch is engaged or faulty.
- Loose wires or connections that intermittently ground ignition kill circuit.
- Quality of fuel (dirt, water, stale, mixture).
- Spark plug lead boot loose on plug.
- Spark plug lead loose.

Engine Will Not Idle

- Engine overheated.
- Faulty spark plug.
- Idle fuel circuit in carburetor plugged/restricted.
- Idle speed adjusting screw improperly set.
- Inadequate fuel supply.
- Low compression.
- Quality of fuel (dirt, water, stale, mixture).
- Restricted fuel tank cap vent.

Engine Overheats

- Cooling fan broken.
- Excessive engine load.
- High crankcase oil level.
- Lean fuel mixture.
- Low crankcase oil level.
- Cooling system components clogged or restricted.

Engine Knocks

- Excessive engine load.
- Incorrect oil viscosity/type.
- Internal wear or damage.
- Low crankcase oil level.
- Quality of fuel (dirt, water, stale, mixture).

Engine Loses Power

- Dirty air cleaner element.
- Engine overheated.
- Excessive engine load.
- Restricted exhaust.
- Faulty spark plug.
- High crankcase oil level.
- Incorrect governor setting.
- Low battery.
- Low compression.
- Low crankcase oil level.
- Quality of fuel (dirt, water, stale, mixture).

Engine Uses Excessive Amount of Oil

- Loose or improperly torqued fasteners.
- Blown head gasket/overheated.
- Breather reed broken.
- Clogged, broken, or inoperative crankcase breather.
- Crankcase overfilled.
- Incorrect oil viscosity/type.
- Worn cylinder bore.
- Worn or broken piston rings.
- Worn valve stems/valve guides.

Oil Leaks from Oil Seals, Gaskets

- Breather reed broken.
- Clogged, broken, or inoperative crankcase breather.
- Loose or improperly torqued fasteners.
- Piston blow by, or leaky valves.
- Restricted exhaust.

EXTERNAL ENGINE INSPECTION

NOTE: It is good practice to drain oil at a location away from workbench. Be sure to allow ample time for complete drainage.

Before cleaning or disassembling engine, make a thorough inspection of its external appearance and condition. This inspection can give clues to what might be found inside engines (and cause) when it is disassembled.

- Check for buildup of dirt and debris on crankcase, cooling fins, grass screen, and other external surfaces. Dirt or debris on these areas can cause overheating.
- Check for obvious fuel and oil leaks, and damaged components. Excessive oil leakage can indicate a clogged or inoperative breather, worn or damaged seals or gaskets, or loose fasteners.
- Check air cleaner components for damage or indications of improper fit and seal.
- Check air cleaner element. Look for holes, tears, cracked or damaged sealing surfaces, or other damage that could allow unfiltered air into engine. A dirty or clogged element could indicate insufficient or improper maintenance.
- Check carburetor throat for dirt. Dirt in throat is further indication that air cleaner was not functioning properly.
- Check if oil level is within operating range on dipstick. If it is above, sniff for gasoline odor.
- Check condition of oil. Drain oil into a container; it should flow freely. Check for metal chips and other foreign particles.

Sludge is a natural by-product of combustion; a small accumulation is normal. Excessive sludge formation could indicate over rich fuel settings, weak ignition, overextended oil change interval or wrong weight or type of oil was used.

CLEANING ENGINE

	⚠ WARNING
	<p>Cleaning Solvents can cause severe injury or death.</p> <p>Use only in well ventilated areas away from ignition sources.</p>
<p>Carburetor cleaners and solvents are extremely flammable. Follow cleaner manufacturer's warnings and instructions on its proper and safe use. Never use gasoline as a cleaning agent.</p>	

After inspecting external condition of engine, clean engine thoroughly before disassembly. Clean individual components as engine is disassembled. Only clean parts can be accurately inspected and gauged for wear or damage. There are many commercially available cleaners that will quickly remove grease, oil, and grime from engine parts. When such a cleaner is used, follow manufacturer's instructions and safety precautions carefully.

Make sure all traces of cleaner are removed before engine is reassembled and placed into operation. Even small amounts of these cleaners can quickly break down lubricating properties of engine oil.

Troubleshooting

CRANKCASE VACUUM TEST

	⚠ WARNING
	Carbon Monoxide can cause severe nausea, fainting or death. Avoid inhaling exhaust fumes. Never run engine indoors or in enclosed spaces.
Engine exhaust gases contain poisonous carbon monoxide. Carbon monoxide is odorless, colorless, and can cause death if inhaled.	

	⚠ WARNING
	Rotating Parts can cause severe injury. Stay away while engine is in operation.
Keep hands, feet, hair, and clothing away from all moving parts to prevent injury. Never operate engine with covers, shrouds, or guards removed.	

A partial vacuum should be present in crankcase when engine is operating. Pressure in crankcase (normally caused by a clogged or improperly assembled breather) can cause oil to be forced out at oil seals, gaskets, or other available spots.

Crankcase vacuum is best measured with either a water manometer or a vacuum gauge (inches of water gauge only). Complete instructions are provided in kits.

To test crankcase vacuum with manometer:

1. Insert rubber stopper into oil fill hole. Be sure pinch clamp is installed on hose and use tapered adapters to connect hose between stopper and one manometer tube. Leave other tube open to atmosphere. Check that water level in manometer is at 0 line. Make sure pinch clamp is closed.
2. Start engine and run no-load high speed.
3. Open clamp and note water level in tube.
Level in engine side should be a minimum of 10.2 cm (4 in.) above level in open side.
If level in engine side is less than specified (low/no vacuum), or level in engine side is lower than level in open side (pressure), check for conditions in table below.
4. Close pinch clamp before stopping engine.

To test crankcase vacuum with vacuum/pressure gauge (inches of water gauge only):

1. Remove dipstick or oil fill plug/cap.
2. Install adapter into oil fill/dipstick tube opening, upside down over end of a small diameter dipstick tube, or directly into engine if a tube is not used. Insert barbed gauge fitting into hole in stopper.
3. Run engine and observe gauge reading.
Analog tester—needle movement to left of 0 is a vacuum, and movement to right indicates a pressure.
Digital tester—depress test button on top of tester.
Crankcase vacuum should be a minimum of 10.2 cm (4 in.) of water. If reading is below specification, or if pressure is present, check table below for possible causes and conclusions.

Condition	Conclusion
Crankcase breather clogged or inoperative.	NOTE: If breather is integral part of valve cover and cannot be serviced separately, replace valve cover and recheck pressure. Disassemble breather, clean parts thoroughly, check sealing surfaces for flatness, reassemble, and recheck pressure.
Seals and/or gaskets leaking. Loose or improperly torque fasteners.	Replace all worn or damaged seals and gaskets. Make sure all fasteners are tightened securely. Use appropriate torque values and sequences when necessary.
Piston blow by or leaky valves (confirm by inspecting components).	Recondition piston, rings, cylinder bore, valves and valves guides.
Restricted exhaust.	Check exhaust screen/spark arrestor (if equipped). Clean or replace as needed. Repair or replace any other damaged/restricted muffler or exhaust system parts.

COMPRESSION TEST

These engines are equipped with an automatic compression release (ACR) mechanism. It is difficult to obtain an accurate compression reading because of ACR mechanism. As an alternative, use cylinder leakdown test described below.

CYLINDER LEAKDOWN TEST

A cylinder leakdown test can be a valuable alternative to a compression test. By pressurizing combustion chamber from an external air source you can determine if valves or rings are leaking, and how badly.

Cylinder leakdown tester is a relatively simple, inexpensive leakdown tester for small engines. This tester includes a quick-connect for attaching adapter hose and a holding tool.

Dual Gauge Test Procedure

1. Run engine until oil temperature reaches and maintains 150°F (66°C) or more for a minimum of 5 minutes. Ideally, engine should be run under normal load conditions.
2. Remove spark plug(s) and air filter from engine.
3. Rotate crankshaft until piston (of cylinder being tested) is at top dead center (TDC) of compression stroke. Hold engine in this position while testing. Holding tool from kit can be used if PTO end of crankshaft is accessible. Lock holding tool onto crankshaft. Install a 3/8 in. breaker bar into hole/slot of holding tool, so it is perpendicular to both holding tool and crankshaft PTO.

If flywheel end is more accessible, use a breaker bar and socket on flywheel nut/screw to hold it in position. An assistant may be needed to hold breaker bar during testing. If engine is mounted in a piece of equipment, it may be possible to hold it by clamping or wedging a driven component. Just be certain engine cannot rotate off TDC in either direction.

4. Connect an air source (at least 100 PSI) to tool.
5. Turn regulator knob clockwise (increase direction). Confirm both gauges read approximately the same air pressure from 0 to 80 PSI. Note any discrepancies between gauges for leakage calculation. Release pressure by turning regulator knob completely counterclockwise before proceeding.
6. Install adapter hose into spark plug hole of cylinder being tested. Use 12 mm x 14 mm adapter if required.
7. Firmly hold engine at TDC. Connect other end of adapter hose to tool quick connect. Turn regulator knob clockwise (increase direction) until left gauge needle reads 20 PSI.

NOTE: When piston is at TDC, little to no holding force should be required when air pressure is applied to cylinder. If excess holding force is required, this indicates piston is not at TDC. Readjust as necessary before proceeding.

8. Slowly turn regulator knob clockwise until left hand gauge maintains selected test pressure (see chart below).

Left Gauge Regulated Pressure Selection
80 PSI Recommended for engines over 200 cc or those exhibiting high leakage at 35 PSI setting.
35 PSI Recommended for single cylinder walk-behind push mower applications.

9. Compare right gauge reading to Test Pressure Chart on next page to identify percentage of leakage. Also refer to Leakdown Test Results chart on next page for colors, conditions, and action required.
10. For engines exhibiting leakage in yellow or red zone, repeat test procedure. Operate engine under normal load conditions prior to test. Confirm piston is at TDC during test.

NOTE: To prevent damage to gauge assembly, always turn pressure regulator knob to zero (counterclockwise) after each test.

Troubleshooting

Test Pressure Chart for Dual Gauge Tool

Left Gauge Regulated Pressure Selection	Right Gauge Reading in PSI											
80 PSI Recommended for engines over 200 cc or those exhibiting high leakage at 35 PSI setting.	80	72	64	56	48	40	32	24	16	8	0	
35 PSI Recommended for single cylinder walk-behind push mower applications.	35	31.5	28	24.5	21	17.5	14	10.5	7	3.5	0	
Percentage of leakage	0%	10%	20%	30%	40%	50%	60%	70%	80%	90%	100%	
	Green Zone				Yellow Zone				Red Zone			

Leakdown Test Results

Test Result	Condition	Action
Gauge reading in low (green) zone.	Piston rings and cylinder in good condition.	No further action required.
Gauge reading in moderate (yellow) zone.	Air escaping from crankcase breather and/or dipstick tube.	Some wear present causing leakage from combustion chamber to crankcase. Repair not required at this time if breather system is functioning normally.
	Air escaping from exhaust.	Exhaust valve leakage present, possibly due to carbon deposits. Repair not required. Carbon cleaning could be performed to reduce leakage.
	Air escaping from intake.	Intake valve leakage present, possibly due to carbon deposits. Repair not required. Carbon cleaning could be performed to reduce leakage.
Gauge reading in high (red) zone. Confirm consecutive leakdown test has been performed AFTER engine has been operated under normal load conditions.	Air escaping from crankcase breather and/or dipstick tube.	Excess wear present causing leakage from combustion chamber to crankcase. Breather system will not function normally and will fail crankcase vacuum test if this condition is truly present. Engine disassembly and analysis required to determine root cause and correction.
	Air escaping from exhaust.	Excess exhaust valve leakage present, possibly due to carbon deposits and/or valve to seat sealing issues. Carbon cleaning may reduce leakage. Valve grind and/or component replacement may be necessary. Excess oil consumption and/or excess heat is a suspect cause and must be resolved to prevent reoccurrence.
	Air escaping from intake.	Excess intake valve leakage present, possibly due to carbon deposits and/or valve to seat sealing issues. Carbon cleaning may reduce leakage. Valve grind and/or component replacement may be necessary. Excess oil consumption through intake valve and/or excess heat is a suspect cause and must be resolved to prevent reoccurrence. Inspect breather system components and intake valve stem sealing.

AIR CLEANER

These systems are CARB/EPA certified and components should not be altered or modified in any way.

Quad-Clean™ Air Cleaner Components

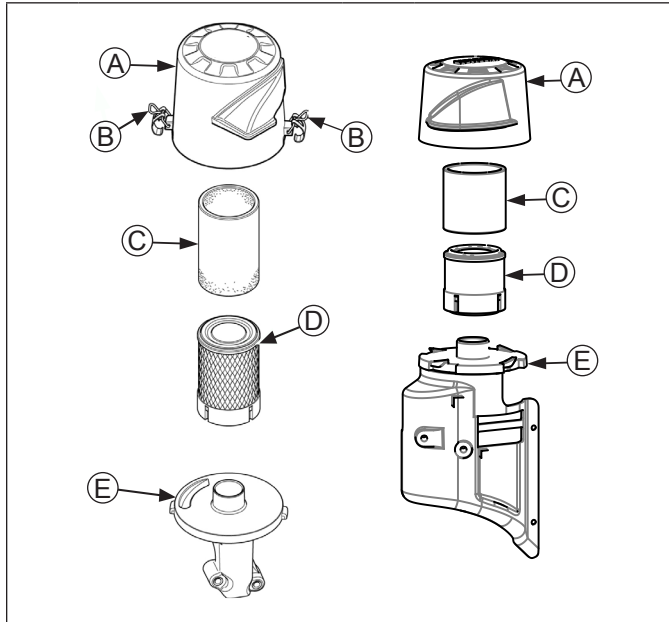

A	Air Cleaner Cover	B	Bail
C	Precleaner	D	Paper Element
E	Air Cleaner Base		

Low-Profile Air Cleaner Components

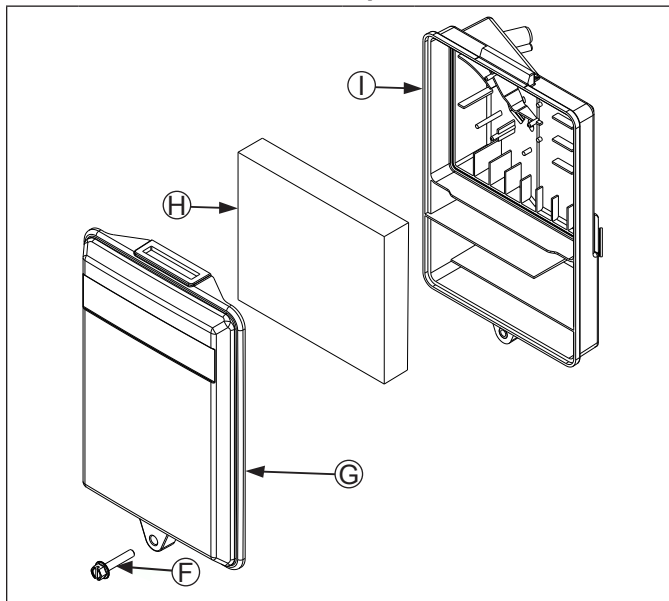

F	Screw	G	Air Cleaner Cover
H	Foam Element	I	Air Cleaner Base

NOTE: Running engine with cover positioned for cold weather operation in normal conditions can damage engine.

NOTE: Operating engine with loose or damaged air cleaner components could cause premature wear and failure. Replace all bent or damaged components.

NOTE: Paper element cannot be blown out with compressed air.

Quad-Clean™

Move bails on air cleaner cover down; remove latches from under tabs on base; remove cover.

or

Turn air cleaner cover (counterclockwise) to release tabs inside cover from base; remove cover.

Precleaner

1. Remove precleaner from paper element.
2. Replace or wash precleaner in warm water with detergent. Rinse and allow to air dry.
3. Lightly oil precleaner with new engine oil; squeeze out excess oil.
4. Reinstall precleaner over paper element.

Paper Element

1. Separate precleaner from element; service precleaner and replace paper element.
2. Install new paper element on base; install precleaner over paper element.

Position air cleaner cover for normal operation (sun decal out) or cold weather operation (snowflake decal out).

Place latches under tabs on base; lift up bails to secure cover.

or

Turn air cleaner cover (clockwise) to secure tabs inside cover in base.

Low-Profile

1. Remove screw and air cleaner cover.
2. Remove foam element from base.
3. Wash foam element in warm water with detergent. Rinse and allow to air dry.
4. Lightly oil foam element with new engine oil; squeeze out excess oil.
5. Reinstall foam element into base.
6. Reinstall cover and secure with screw.

Air Cleaner/Intake

Oil Bath

Some engines are equipped with an oil bath air cleaner. Follow maintenance and oil change information specified in this section and in Maintenance Schedule. Earlier design had a single foam filter that was later replaced by 2 foam elements.

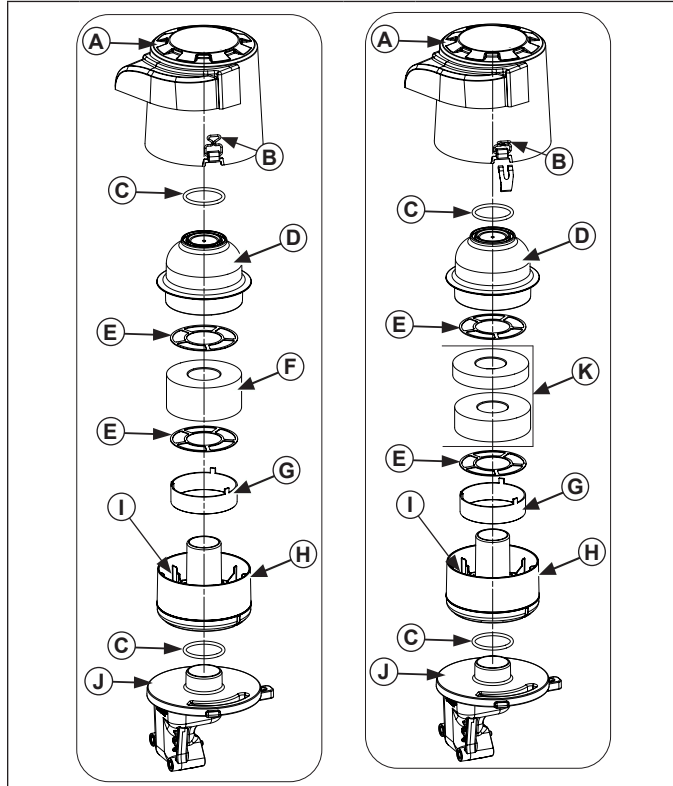

A	Air Cleaner Cover	B	Bail
C	O-Ring	D	Foam Filter Cover
E	Foam Filter Support Plate	F	Foam Filter
G	Oil Retainer Ring	H	Oil Reservoir Cup
I	Oil Level Mark	J	Air Cleaner Base
K	Foam Element Kit		

Move bails on air cleaner cover down; remove latches from under tabs on base; remove cover.

1. Remove foam filter cover from oil reservoir cup. Remove foam filter support plate and foam filter or foam elements.
2. Replace or wash foam filter/foam elements in warm water with detergent. Rinse and allow to air dry.
3. Lightly oil foam filter or foam elements with new engine oil; squeeze out excess oil.
4. Remove foam filter support plate and oil retainer ring from oil reservoir cup.
5. Remove oil reservoir cup from base. Empty oil from cup and wash cup in warm water with detergent. Rinse and dry cup.

6. Make sure O-ring is in place on air cleaner base. Set oil reservoir cup on base.
7. Fill oil reservoir cup up to oil level mark with same grade of oil as in crankcase. Refer to Oil Recommendations in Maintenance.

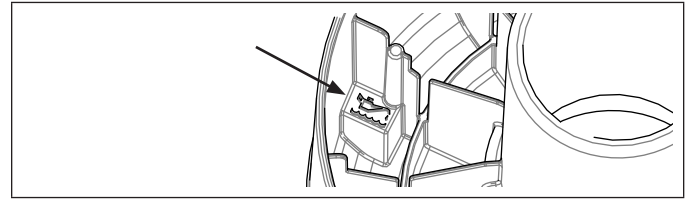

8. Reinstall oil retainer ring and foam filter support plate in oil reservoir cup.
9. Single Foam Filter: Reinstall foam filter on oil reservoir cup. Place foam filter support plate on filter. Reinstall foam filter cover. Make sure O-ring is in place on top of filter cover.

2 Foam Elements: Reinstall taller foam element first, then shorter foam element on oil reservoir cup. Place foam filter support plate on elements. Reinstall foam filter cover. Make sure O-ring is in place on top of filter cover.

Position air cleaner cover for normal operation (sun decal out) or cold weather operation (snowflake decal out). Place latches under tabs on base; lift up bails to secure cover.

BREATHER TUBE

Ensure both ends of breather tube are properly connected.

AIR COOLING

	WARNING
	<p>Hot Parts can cause severe burns. Do not touch engine while operating or just after stopping.</p>
<p>Never operate engine with heat shields or guards removed.</p>	

Proper cooling is essential. To prevent over heating, clean screens, cooling fins, and other external surfaces of engine. Avoid spraying water at wiring harness or any electrical components. Refer to Maintenance Schedule.

Typical carbureted fuel system and related components include:

- Fuel tank.
- Fuel lines.
- In-line fuel filter.
- Fuel tank filter.
- Carburetor.
- Fuel strainer screen in carburetor.

FUEL RECOMMENDATIONS

Refer to Maintenance.

FUEL LINE

Low permeation fuel line must be installed on carbureted Rehlko engines to maintain EPA and CARB regulatory compliance.

FUEL FILTER

Fuel Tank Filter (if equipped)

A serviceable fuel tank filter is located under fuel tank cap, in filler neck.

Daily or as required clean filter of any accumulation as follows:

1. Remove fuel tank cap and filter.
2. Clean filter with solvent, replace if damaged.
3. Wipe filter and insert it.
4. Tighten fuel tank cap securely.

FUEL SYSTEM TESTS

When engine starts hard, or turns over but will not start, fuel system might be causing problems. Test fuel system by performing following test.

1. Check for fuel in combustion chamber.
 - a. Disconnect and ground spark plug lead.
 - b. Close choke on carburetor.
 - c. Crank engine several times.
 - d. Remove spark plug and check for fuel at tip.
2. Check for fuel flow from tank to carburetor.
 - a. Remove fuel line from inlet fitting of carburetor.
 - b. Use an approved fuel container to catch fuel, and hold line below bottom of tank to observe fuel flow.
3. Check operation of fuel shut-off valve.
 - a. Remove fuel sediment bowl under inlet fitting of carburetor.
 - b. Turn fuel shut-off valve ON and OFF and observe operation.

Fuel Valve

	⚠ WARNING
	Explosive Fuel can cause fires and severe burns. Do not fill fuel tank while engine is hot or running.
Gasoline is extremely flammable and its vapors can explode if ignited. Store gasoline only in approved containers, in well ventilated, unoccupied buildings, away from sparks or flames. Spilled fuel could ignite if it comes in contact with hot parts or sparks from ignition. Never use gasoline as a cleaning agent.	

NOTE: Models with a low-profile air cleaner do not have fuel valve.

1. Stop engine.
2. Remove securing hardware and carburetor cover panel.
3. Turn fuel valve lever to OFF position.
4. Remove fuel valve cup.
5. Clean fuel valve cup with solvent and wipe it off.
6. Check O-ring, replace if damaged. Check screen for blockage or damage, replace if necessary. New screen must be located on pick-up tube.
7. Place O-ring on screen followed by fuel valve cup. Rotate fuel valve cup until it is finger tight. Turn with a wrench 1/2 to 3/4 turn.
8. Turn fuel valve to ON position and check for leaks. If fuel valve cup leaks repeat step 7.
9. Reinstall carburetor cover panel, using hardware removed in step 2 to secure.

Condition	Conclusion
Fuel at tip of spark plug.	Fuel is reaching combustion chamber.
No fuel at tip of spark plug.	Check fuel flow from fuel tank (step 2).
Fuel flows from fuel line.	Check operation of fuel shut-off valve (step 3).
No fuel flow from fuel line.	Check fuel tank vent, in-line filter threaded into tank, and fuel line. Correct any observed problem and reconnect line.
Fuel flows from valve.	Check for dirt and water in sediment bowl and screen. Clean bowl and screen as needed. Check for faulty carburetor, refer to Carburetor.
No fuel flows from valve.	Check for a restriction in fuel shut-off valve or inlet elbow.

Fuel System

CARBURETOR



⚠ WARNING

Explosive Fuel can cause fires and severe burns.

Do not fill fuel tank while engine is hot or running.

Gasoline is extremely flammable and its vapors can explode if ignited. Store gasoline only in approved containers, in well ventilated, unoccupied buildings, away from sparks or flames. Spilled fuel could ignite if it comes in contact with hot parts or sparks from ignition. Never use gasoline as a cleaning agent.

Typical One-Barrel Carburetor Components

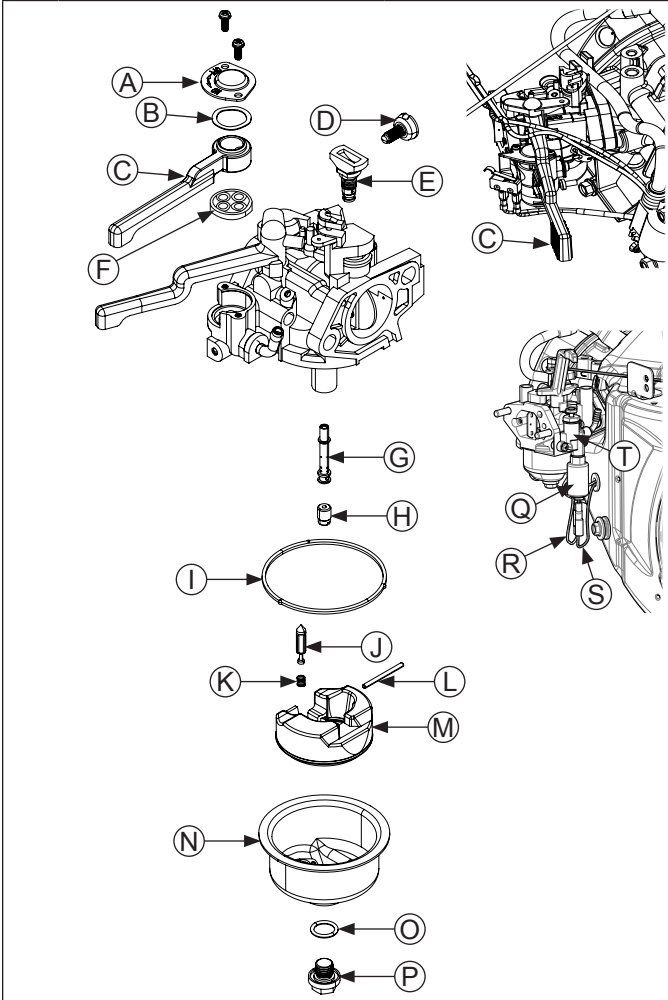

A	Fuel Shut-Off	B	Wave Washer
C	Fuel Shut-Off (and Ignition, if equipped)	D	Low Idle Speed Adjusting Screw
E	Idle Jet	F	Fuel Shut-Off Gasket
G	Main Nozzle Tube	H	Main Jet
I	Bowl Gasket	J	Fuel Inlet Needle
K	Spring	L	Hinge Pin
M	Float	N	Fuel Bowl
O	Bowl Retaining Screw Gasket	P	Bowl Retaining Screw
Q	Fuel Shut-off Solenoid (if equipped)	R	Black Solenoid Ground Lead (if equipped)
S	Red Solenoid Lead (if equipped)	T	Solenoid Base Assembly (if equipped)

These engines are equipped with a fixed main jet carburetor. Carburetor is designed to deliver correct fuel-to-air mixture to engine under all operating conditions. Idle mixture is set at factory and cannot be adjusted.

Troubleshooting Checklist

When engine starts hard, runs rough, or stalls at low idle speed, check these areas before adjusting or disassembling carburetor.

1. Make sure fuel tank is filled with clean, fresh gasoline.
2. Make sure fuel tank cap vent is not blocked and is operating properly.
3. Make sure fuel is reaching carburetor. This includes checking fuel shut-off valve, fuel tank filter screen, in-line fuel filter, fuel lines and fuel pump for restrictions or faulty components as necessary.
4. Make sure air cleaner base and carburetor are securely fastened to engine using gaskets in good condition.
5. Make sure air cleaner element (including precleaner if equipped) is clean and all air cleaner components are fastened securely.
6. Make sure ignition system, governor system, exhaust system, and throttle and choke controls are operating properly.

Troubleshooting-Carburetor Related Causes

Condition	Possible Cause	Conclusion
Engine starts hard, runs rough, or stalls at idle speed.	Low idle fuel mixture (some models)/ speed improperly adjusted.	Adjust idle speed screw or clean carburetor.
Engine runs rich (indicated by black, sooty exhaust smoke, misfiring, loss of speed and power, governor hunting, or excessive throttle opening).	Clogged air cleaner.	Clean or replace air cleaner.
	Choke partially closed during operation.	Check choke lever/linkage to ensure choke is operating properly.
	Dirt under fuel inlet needle.	Remove needle; clean needle and seat and blow with compressed air.
	Bowl vent or air bleeds plugged.	Clean vent, ports, and air bleeds. Blow out all passages with compressed air.
	Leaky, cracked, or damaged float.	Submerge float to check for leaks.
Engine runs lean (indicated by misfiring, loss of speed and power, governor hunting, or excessive throttle opening).	Intake air leak.	Check if carburetor is loose or one of intake gaskets is leaking.
	Idle holes plugged; dirt in fuel delivery channels.	Clean main fuel jet and all passages; blow out with compressed air.
Fuel leaks from carburetor.	Float damaged.	Submerge float to check for leaks. Replace float.
	Dirt under fuel inlet needle.	Remove needle; clean needle and seat and blow with compressed air.
	Bowl vents plugged.	Blow out with compressed air.
	Carburetor bowl gasket leaks.	Replace gasket.

Fuel Shut-off Solenoid (if equipped)

Some carburetors are equipped with a fuel shut-off solenoid. Solenoid threads into a base assembly that is attached to carburetor body. Solenoid has a spring-loaded pin that retracts when 12 volts is applied to lead, allowing fuel flow to main jet. When current is removed, pin extends blocking fuel flow.

Below is a simple test, performed with engine off, that can determine if solenoid is functioning properly.

1. Shut off fuel, disconnect wires, and remove solenoid from carburetor. When solenoid is loosened and removed, gas will leak out of carburetor. Have a container ready to catch fuel.
2. Wipe tip of solenoid with a shop towel or blow off with compressed air to remove any remaining fuel. Take solenoid to a location with good ventilation and no fuel vapors present. You will also need a 12 volt power source that can be switched on and off.
3. Be sure power source is switched OFF. Connect positive power source lead to red lead of solenoid. Connect negative power source lead to black lead of solenoid.
4. Turn power source ON and observe pin in center of solenoid. Pin should retract with power ON and return to its original position with power OFF. Test several times to verify operation.

Replace solenoid if pin does not move.

If solenoid operates, reinstall solenoid. Torque solenoid to 7 N·m (62 in lb.). Reconnect solenoid wires.

Carburetor Circuits

Float

Fuel level in bowl is maintained by float and fuel inlet needle. Buoyant force of float stops fuel flow when engine is at rest. When fuel is being consumed, float will drop and fuel pressure will push inlet needle away from seat, allowing more fuel to enter bowl. When demand ceases, buoyant force of float will again overcome fuel pressure, rising to predetermined setting and stop flow.

Slow and Mid-Range

At low speeds engine operates only on slow circuit. As a metered amount of air is drawn through slow air bleed jets, fuel is drawn through main jet and further metered through slow jet. Air and fuel are mixed in body of slow jet and exit to idle progression (transfer port) chamber. From idle progression chamber, air fuel mixture is metered through idle port passage. At low idle air/fuel mixture is controlled by setting of idle fuel adjusting screws. This mixture is then mixed with main body of air and delivered to engine. As throttle plate opening increases, greater amounts of air/fuel mixture are drawn in through fixed and metered idle progression holes. As throttle plate opens further, vacuum signal becomes great enough at venturi so main circuit begins to work.

Main (high-speed)

At high speeds/loads engine operates on main circuit. As a metered amount of air is drawn through air jet, fuel is drawn through main jet. Air and fuel are mixed in main nozzles then enters main body of airflow where further mixing of fuel and air occurs. This mixture is then delivered to combustion chamber. Carburetor has a fixed main circuit; no adjustment is possible.

Fuel System

Carburetor Adjustments

NOTE: Carburetor adjustments should be made only after engine has warmed up.

Carburetor is designed to deliver correct fuel-to-air mixture to engine under all operating conditions. Main fuel jet is calibrated at factory and is not adjustable. Idle fuel adjusting needles are also set at factory and are not adjustable.

Low Idle Speed (RPM) Adjustment

NOTE: Actual low idle speed depends on application. Refer to equipment manufacturer's recommendations. Low idle speed for basic engines is 1800 RPM.

1. Place throttle control into idle or slow position. Turn low idle speed adjusting screw in or out to obtain allow idle speed of 1800 RPM (± 75 RPM).

High Idle Speed (RPM) Adjustment (if equipped)

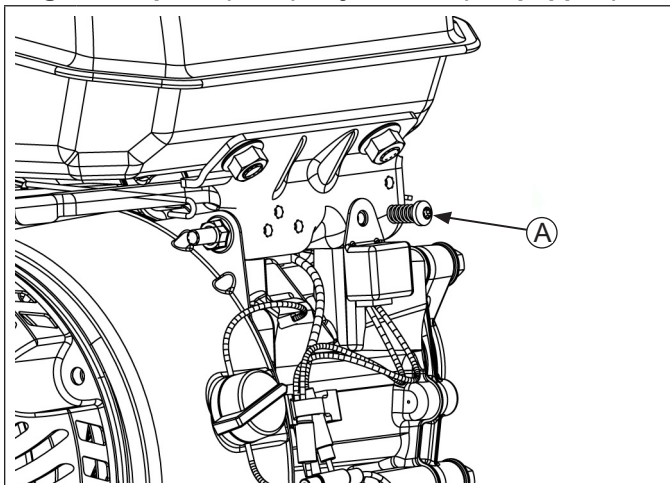



A High Idle Speed Adjusting Stop Screw

NOTE: High idle speed is also specified by equipment manufacturer. Set according to recommendations. High idle speed for basic engines is 3600 RPM (± 150 RPM).

1. Set high idle speed by turning high idle speed adjusting stop screw in or out. Do not exceed 3750 RPM.

Carburetor Servicing

	WARNING
	Accidental Starts can cause severe injury or death.
	Disconnect and ground spark plug lead(s) before servicing.
Before working on engine or equipment, disable engine as follows: 1) Disconnect spark plug lead(s). 2) Disconnect negative (-) battery cable from battery.	

NOTE: Main and slow jets are fixed and size specific and can be removed if required. Fixed jets for high altitudes are available.

- Inspect carburetor body for cracks, holes, and other wear or damage.
- Inspect float for cracks, holes, and missing or damaged float tabs. Check float hinge and shaft for wear or damage.
- Inspect fuel inlet needle and seat for wear or damage.

1. Perform removal procedures for appropriate air cleaner and carburetor outlined in Disassembly.
2. Clean exterior surfaces of dirt or foreign material before disassembling carburetor. If equipped with a fuel shut-off solenoid, remove screws securing solenoid base assembly to carburetor body. Remove bowl retaining screw, and carefully separate fuel bowl from carburetor. Do not damage fuel bowl O-rings. Transfer any remaining fuel into an approved container. Save all parts. Fuel can also be drained prior to bowl removal by loosening/removing bowl drain screw.
3. Remove float pin and inlet needle. Seat for inlet needle is not serviceable and should not be removed.
4. Clean carburetor bowl and inlet seat areas as required.
5. Carefully remove main jet from carburetor. After main jet is removed, main nozzles can be removed through bottom of main towers. Note orientation/direction of nozzles. End with 2 raised shoulders should be out/down adjacent to main jets.
6. Save parts for cleaning and reuse unless a jet kit is also being installed. Clean slow jets using compressed air or carburetor cleaner, do not use wire.

NOTE: There are 2 O-rings on body of idle jet.

Carburetor is now disassembled for appropriate cleaning and installation of parts in overhaul kit.

If equipped with a fuel shut-off solenoid, secure solenoid base assembly to carburetor body with screws. Torque screws to 1.5 N·m (13 in. lb.).

High Altitude Operation

If this engine is operated at an altitude of 4000 ft. (1219 meters) or above, a high altitude carburetor kit is required. To obtain high altitude carburetor kit information or to find a Rehlko authorized dealer, visit engines.rehlko.com or call 1-800-544-2444 (U.S. and Canada).

This engine should be operated in its original configuration below 4000 ft. (1219 meters).

Operating this engine with the wrong engine configuration at a given altitude may increase its emissions, decrease fuel efficiency and performance, and result in damage to the engine.

GOVERNOR

These engines are equipped with an electronic governor or a mechanical governor.

ELECTRONIC GOVERNOR

Components

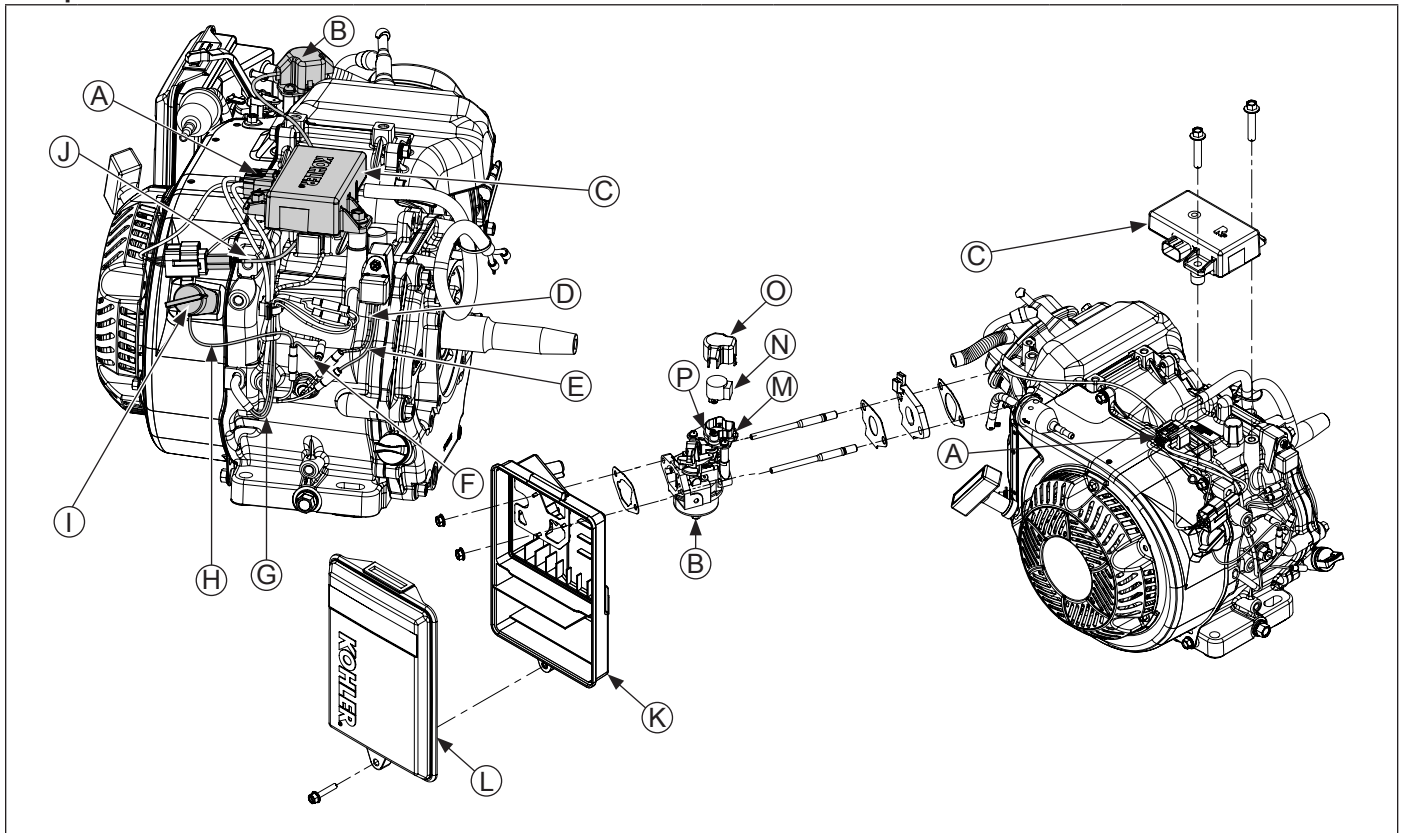

A	Wiring Assembly Harness	B	Carburetor Assembly	C	Electronic Governor Control	D	Yellow Oil Sensor Lead to Oil Alert Green Lead
E	Green Lead from Electronic Governor Control to Oil Alert Black Lead	F	Ignition Switch Lead to Ignition Kill Lead	G	Red Leads from Electronic Governor Control to Red Stator Leads	H	White Lead from Electronic Governor Control to Ignition Switch
I	Ignition Switch	J	Carburetor Stepper Motor Leads to Electronic Governor Control Leads	K	Air Cleaner Base	L	Air Cleaner Cover
M	Stepper Motor Bracket	N	Stepper Motor	O	Stepper Motor Cover	P	Stepper Motor Base

Electronic governor regulates engine speed at varying loads. This electronic governor includes:

- Electronic governor control.
- Stepper motor.
- Wiring assembly harness.

Governor System

Electronic Governor Troubleshooting Flow Chart

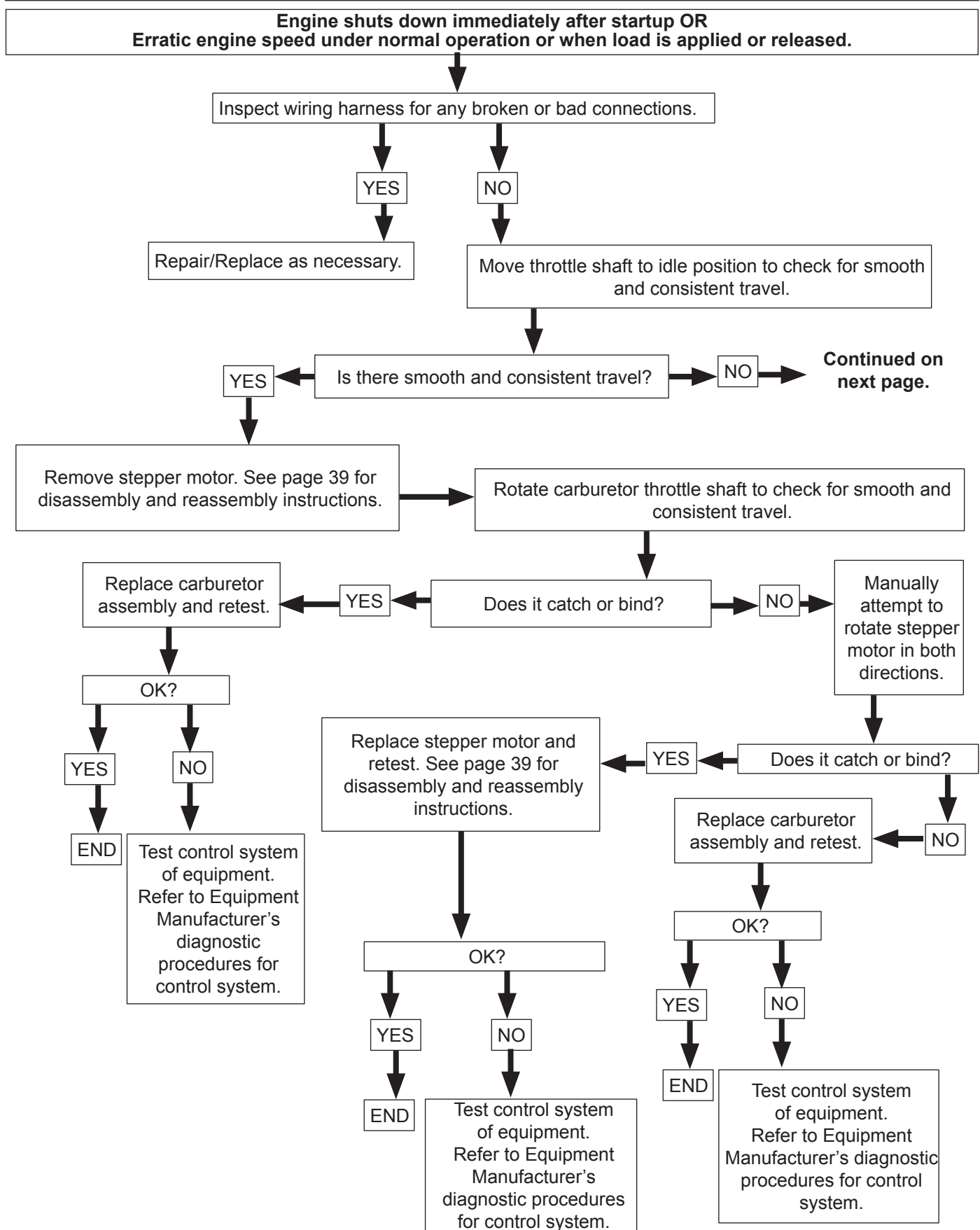

Electronic Governor Troubleshooting Flow Chart Continued

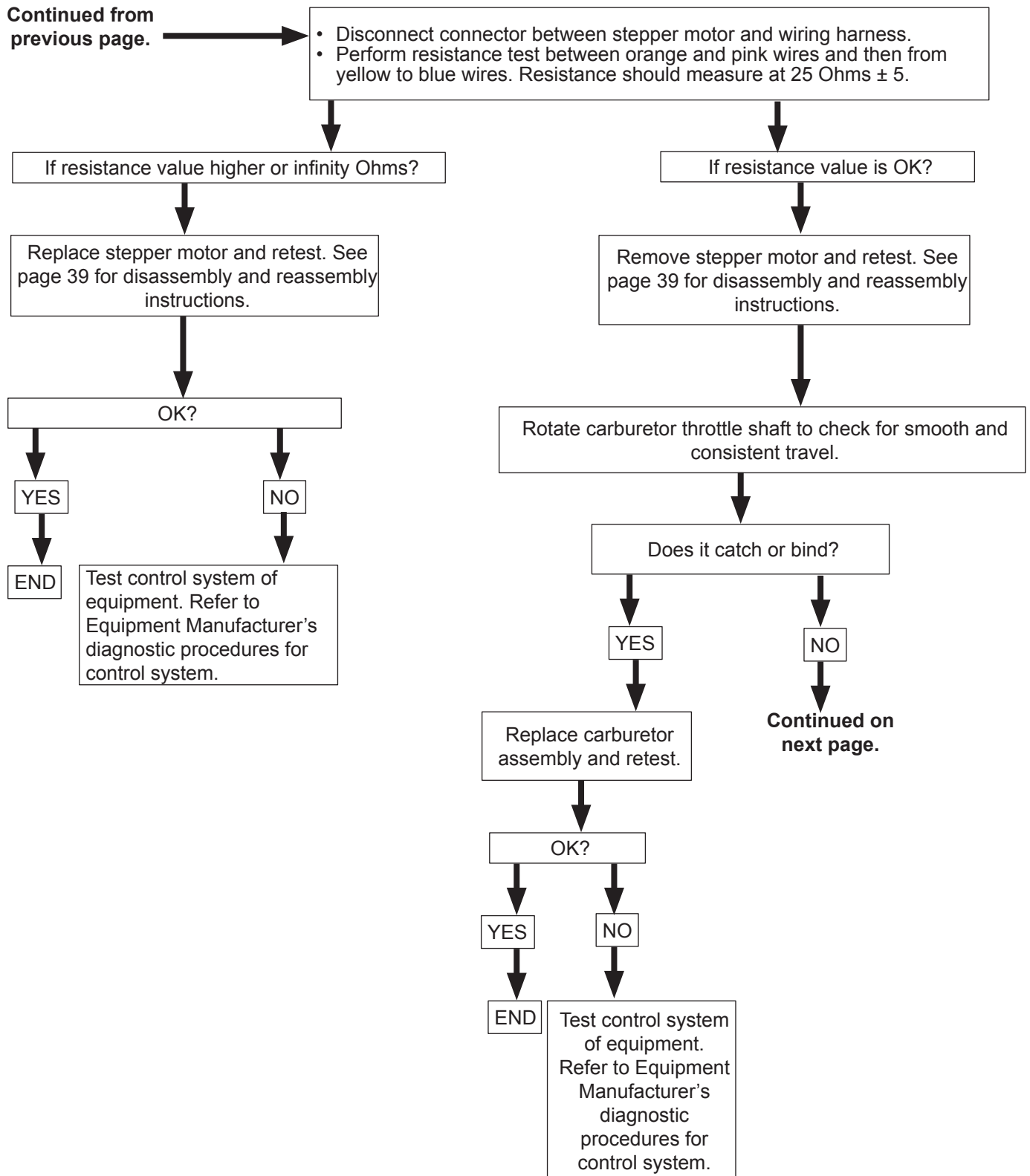

Governor System

Electronic Governor Troubleshooting Flow Chart Continued

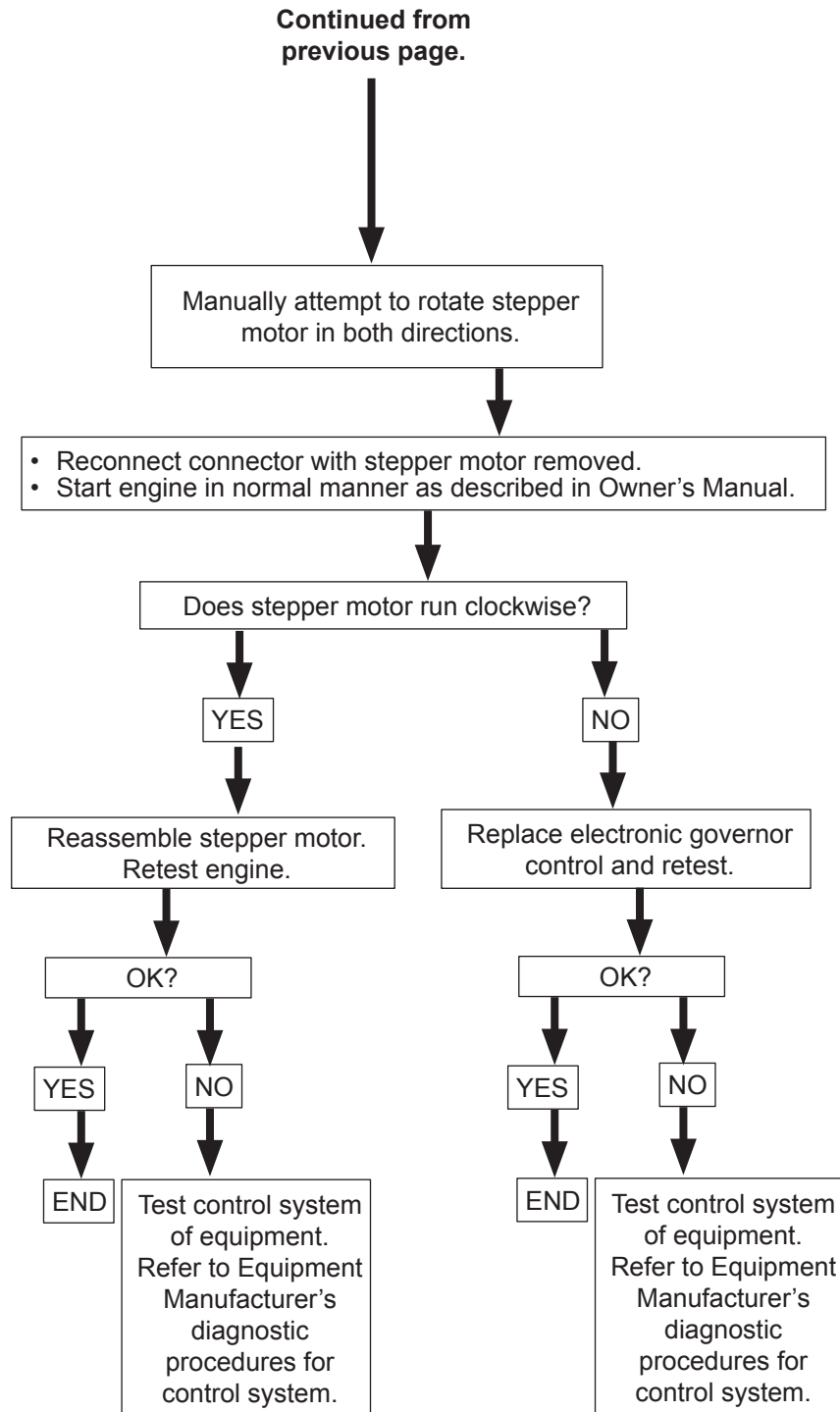

Electronic Governor Troubleshooting Flow Chart Continued

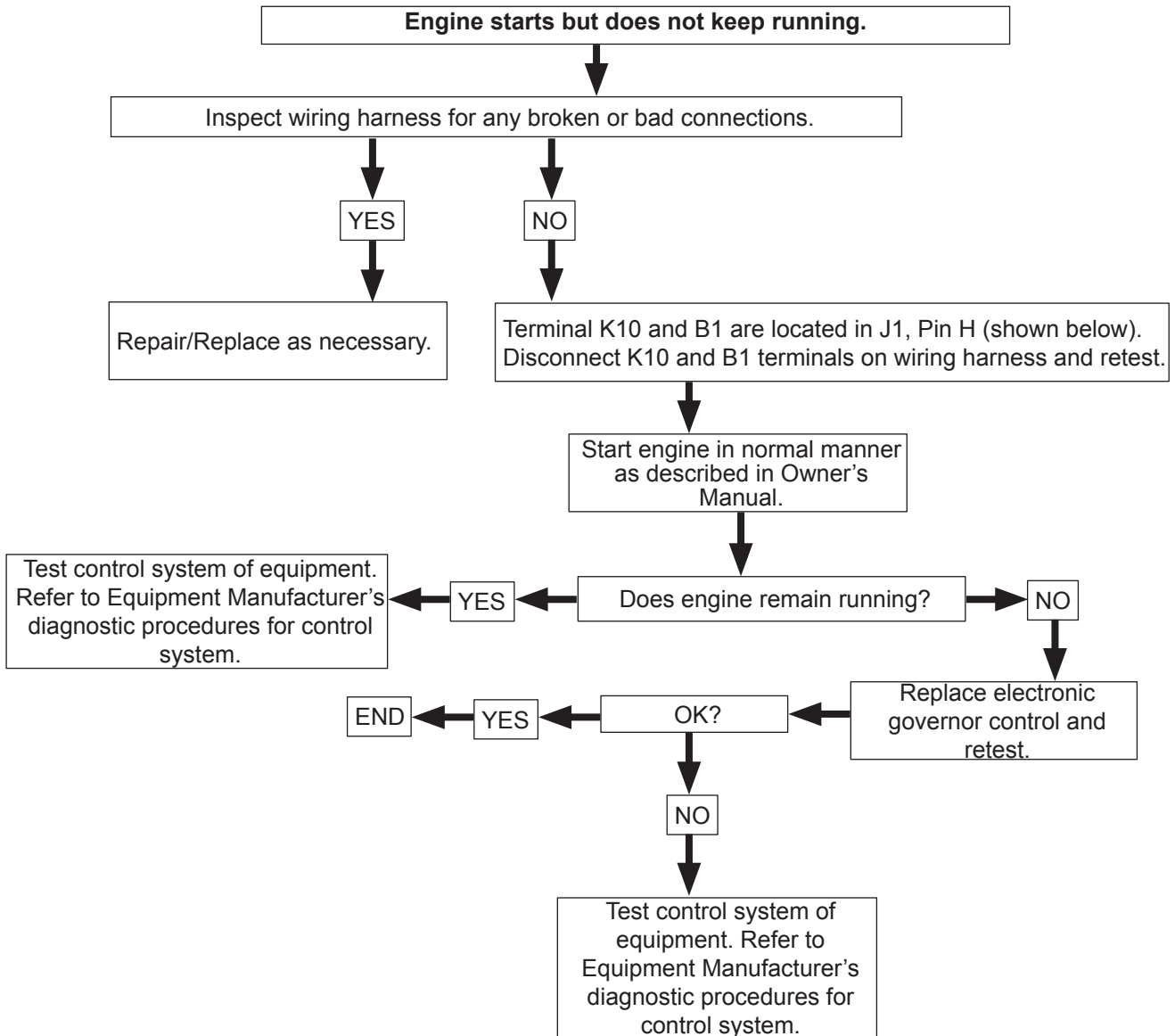

Basic Wiring Harness Assembly Diagram

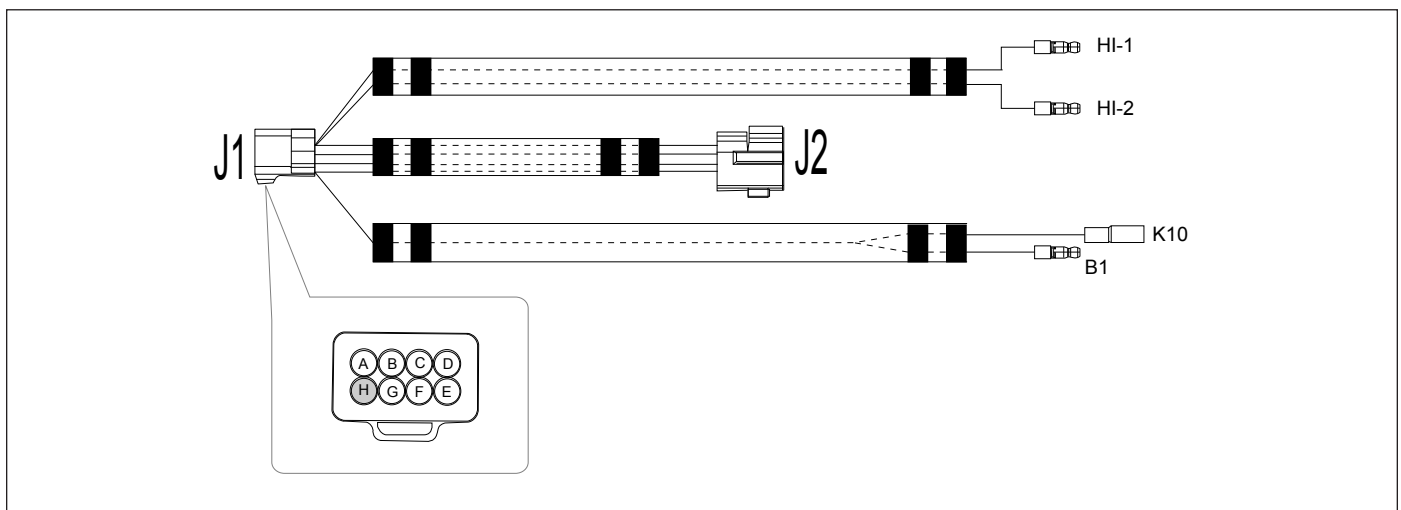

Governor System

Electronic Governor Troubleshooting Flow Chart Continued

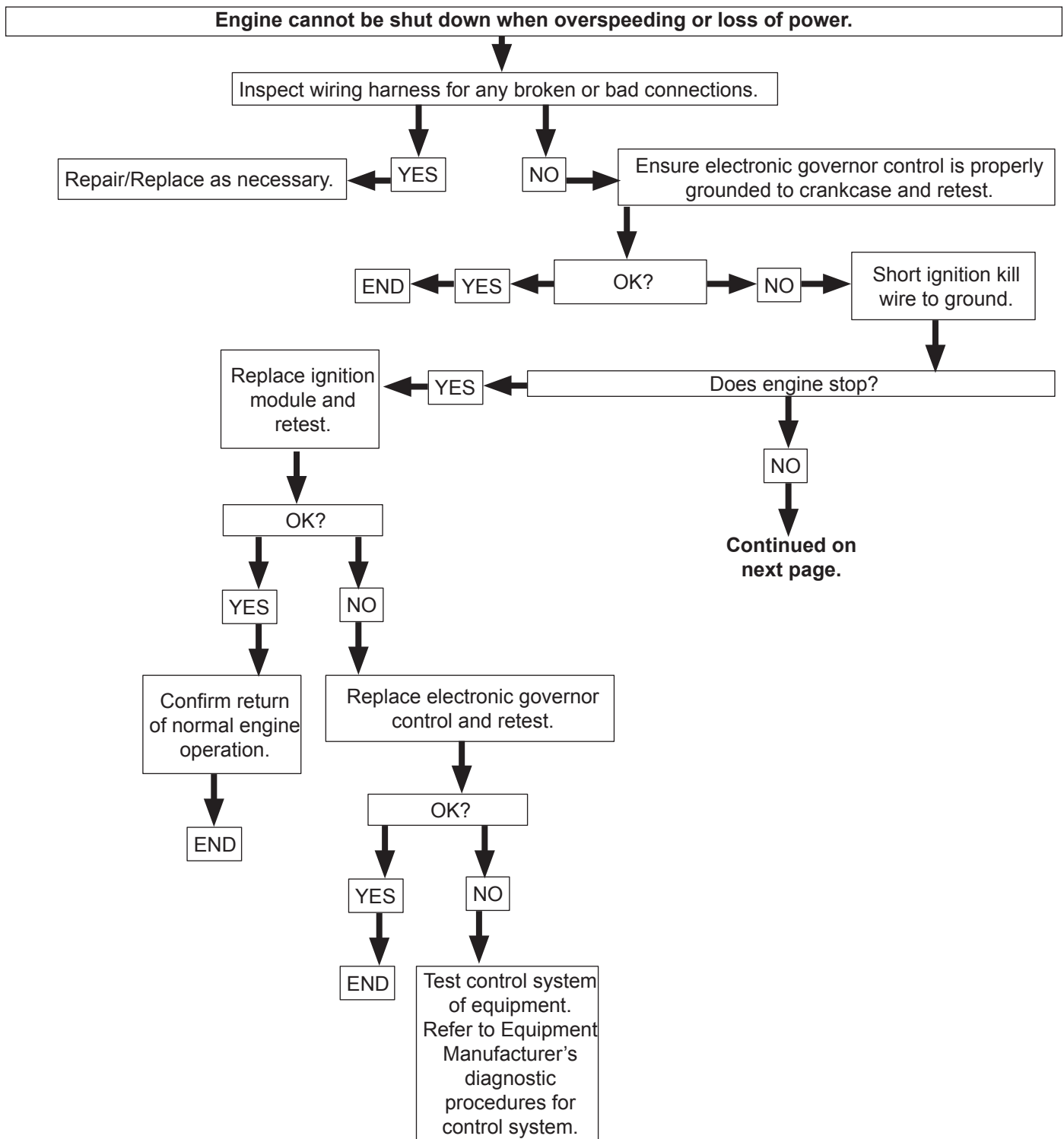

Electronic Governor Troubleshooting Flow Chart Continued

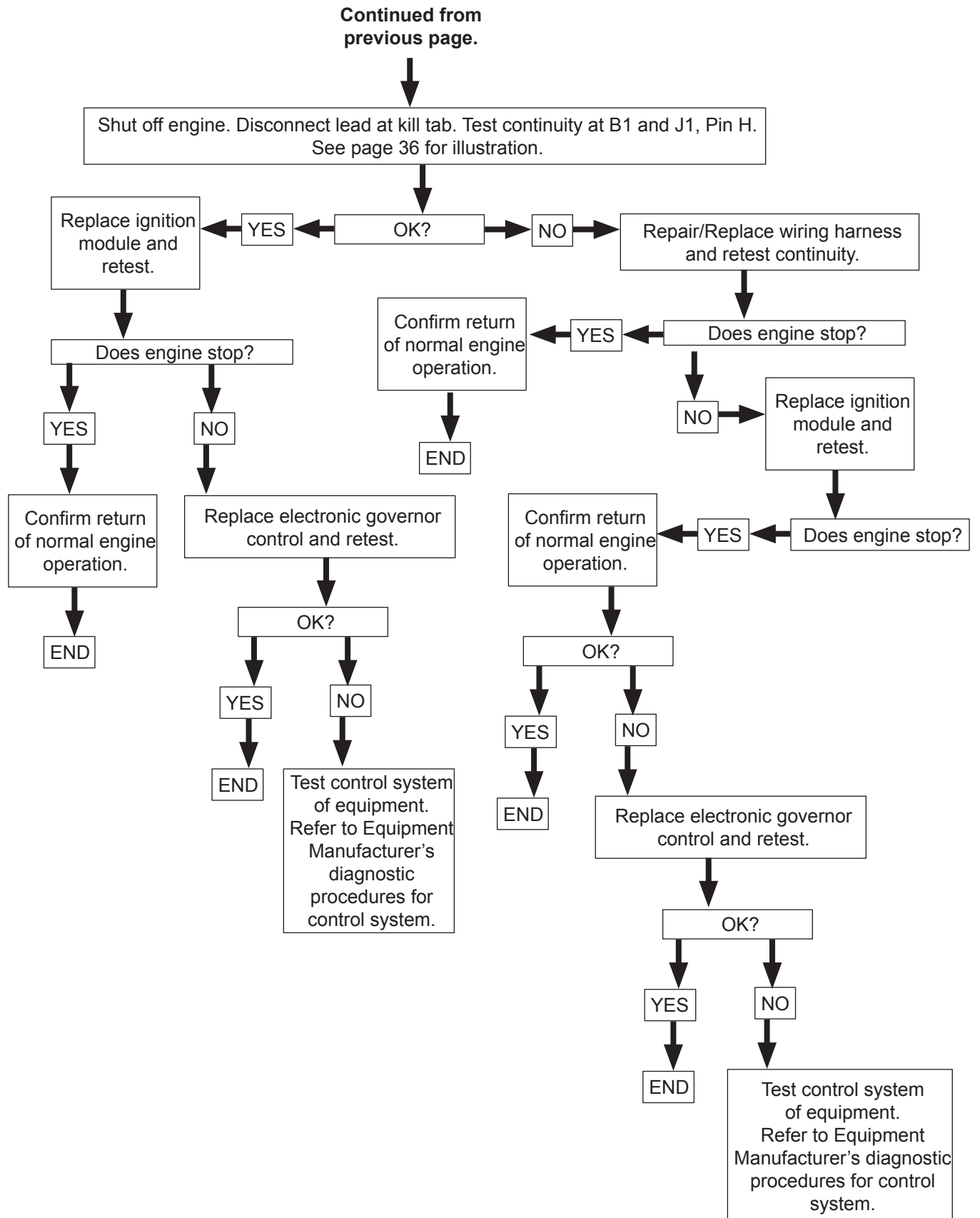

Governor System

Stepper Motor

Stepper Motor Components

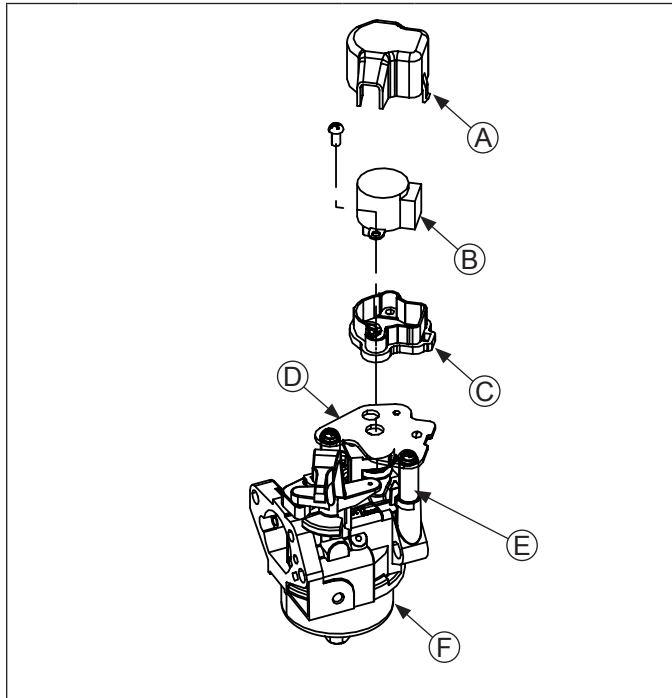

A	Stepper Motor Cover	B	Stepper Motor
C	Stepper Motor Bracket	D	Stepper Motor Base
E	Stepper Motor Post	F	Carburetor

Stepper Motor Servicing

Disassembly

NOTE: It is not necessary to remove stepper motor base from carburetor assembly when replacing stepper motor.

1. Disconnect connector between stepper motor and wiring harness.
2. Release clips on sides of stepper motor cover and remove cover.
3. Remove screw securing stepper motor to stepper motor bracket.
4. Remove stepper motor.

Reassembly

1. Install stepper motor into bracket and position on stepper motor base. Secure with screw and tighten.
2. Route wire harness so that it feeds through stepper motor cover. Install cover.
3. Reconnect connector between stepper motor and wiring harness.

Electronic Governor Control

Electronic Governor Control Components

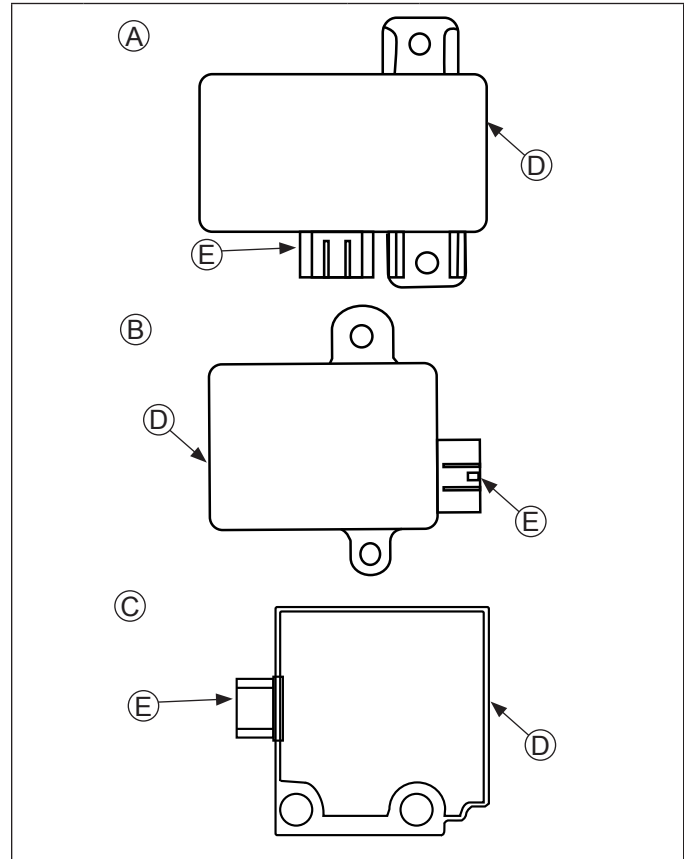

A	CH395	B	CH440
C	CH270	D	Electronic Governor Control
E	Wiring Harness Connector		

Electronic Governor Control Servicing

Disassembly

1. Mark wire locations and remove wires from control panel.
2. Remove wire harness from electronic governor control.
3. Remove screws securing electronic governor control to crankcase.

Reassembly

1. Place governor control in position on crankcase and secure with two screws. Torque screws to 24 N·m (212 in. lb.).
2. Install wires to control panel.
3. Install wiring harness to electronic governor control.

MECHANICAL GOVERNOR

CH245/CH255 Governor Components

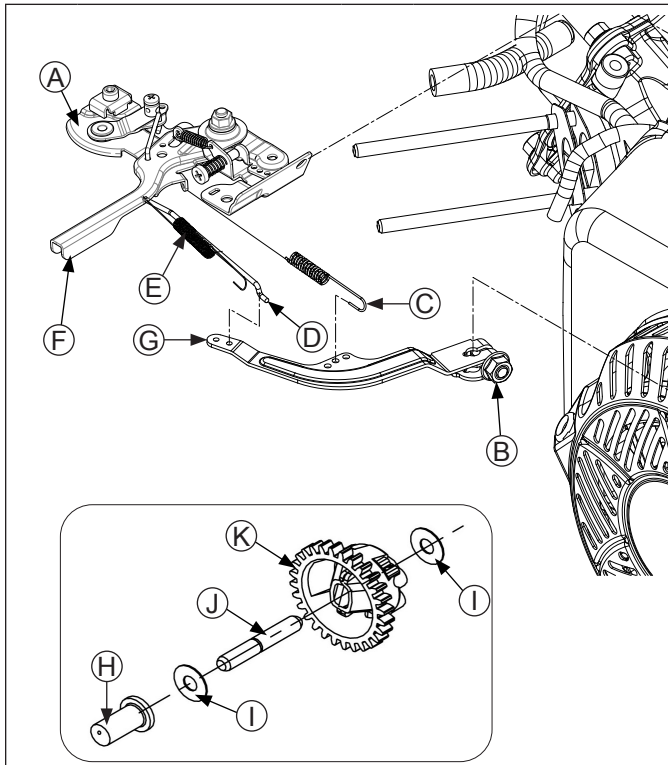

A	Control Assembly	B	Nut
C	Governor Spring	D	Throttle Linkage
E	Dampening Spring	F	Throttle Control Lever
G	Governor Lever	H	Cup
I	Washer	J	Governor Gear Shaft
K	Governor Gear		

Governed speed setting is determined by position of throttle control. It can be variable or constant, depending on engine application.

Governor is designed to hold engine speed constant under changing load conditions. Most engines are equipped with a centrifugal flyweight mechanical governor. Governor gear/flyweight mechanism of mechanical governor is mounted inside crankcase and is driven off gear on crankshaft.

This governor design works as follows:

- Centrifugal force acting on rotating governor gear assembly causes flyweights to move outward as speed increases. Governor spring tension moves them inward as speed decreases.
- As flyweights move outward, they cause regulating pin to move outward.
- Regulating pin contacts tab on cross shaft causing shaft to rotate.

- One end of cross shaft protrudes through crankcase. Rotating action of cross shaft is transmitted to throttle lever of carburetor through external throttle linkage.
- When engine is at rest, and throttle is in fast position, tension of governor spring holds throttle plate open. When engine is operating, governor gear assembly is rotating. Force applied by regulating pin against cross shaft tends to close throttle plate. Governor spring tension and force applied by regulating pin balance each other during operation, to maintain engine speed.
- When load is applied and engine speed and governor gear speed decreases, governor spring tension moves governor arm to open throttle plate wider. This allows more fuel into engine, increasing engine speed. As speed reaches governed setting, governor spring tension and force applied by regulating pin will again offset each other to hold a steady engine speed.

Governor Adjustments

Initial Adjustment Procedure

NOTE: Make sure carburetor is mounted and secured in place when adjustment is being made/checked.

Make this initial adjustment whenever governor lever is loosened or removed from cross shaft. To ensure proper setting, make sure throttle linkage is connected to governor lever and to carburetor throttle lever.

Adjust as follows:

1. Close fuel shut-off valve.
2. Remove air cleaner outer cover. Then either reposition fuel tank to access governor shaft and lever joint, or disconnect fuel line and remove tank from engine.
3. Loosen governor lever mounting nut.
4. Move governor lever clockwise until it stops.
5. Rotate governor shaft clockwise until it stops.
6. Hold both in this position and torque governor lever nut to 12 N·m (106 in. lb.).

Governor System

CH260-CH440 Governor Components

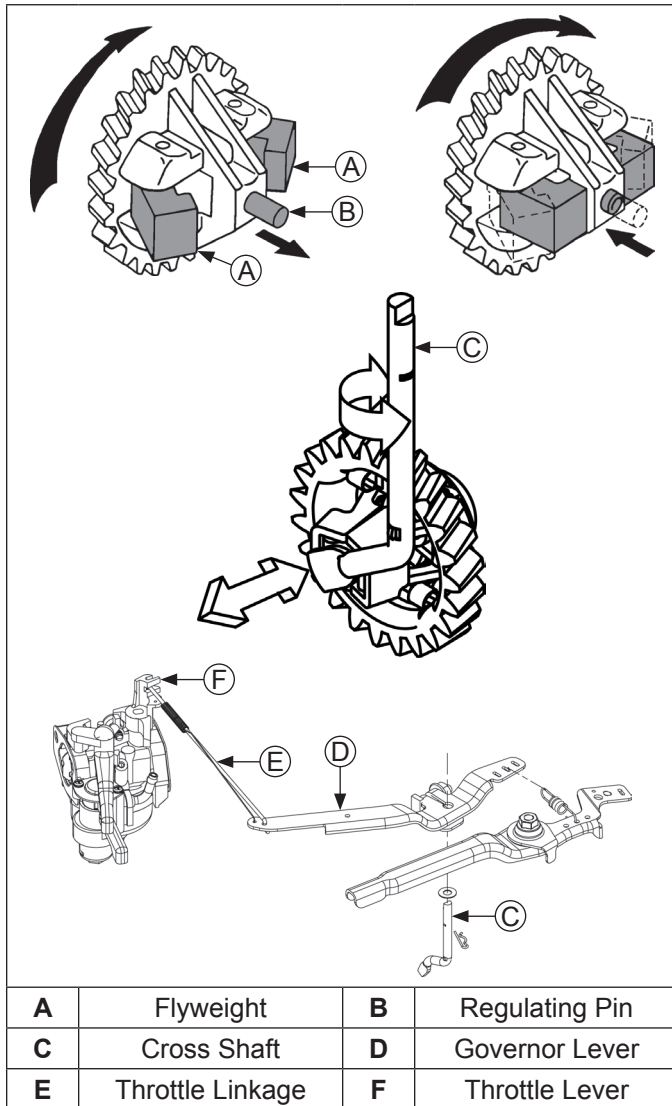

Governed speed setting is determined by position of throttle control. It can be variable or constant, depending on engine application.

Governor is designed to hold engine speed constant under changing load conditions. Most engines are equipped with a centrifugal flyweight mechanical governor. Governor gear/flyweight mechanism of mechanical governor is mounted inside crankcase and is driven off gear on camshaft.

This governor design works as follows:

- Centrifugal force acting on rotating governor gear assembly causes flyweights to move outward as speed increases. Governor spring tension moves them inward as speed decreases.
- As flyweights move outward, they cause regulating pin to move outward.
- Regulating pin contacts tab on cross shaft causing shaft to rotate.
- One end of cross shaft protrudes through crankcase. Rotating action of cross shaft is transmitted to throttle lever of carburetor through external throttle linkage.
- When engine is at rest, and throttle is in fast position,

tension of governor spring holds throttle plate open. When engine is operating, governor gear assembly is rotating. Force applied by regulating pin against cross shaft tends to close throttle plate. Governor spring tension and force applied by regulating pin balance each other during operation, to maintain engine speed.

- When load is applied and engine speed and governor gear speed decreases, governor spring tension moves governor arm to open throttle plate wider. This allows more fuel into engine, increasing engine speed. As speed reaches governed setting, governor spring tension and force applied by regulating pin will again offset each other to hold a steady engine speed.

Governor Adjustments

NOTE: Make sure carburetor is mounted and secured in place when adjustment is being made/checked.

Initial Adjustment Procedure

Make this initial adjustment whenever governor lever is loosened or removed from cross shaft. To ensure proper setting, make sure throttle linkage is connected to governor lever and to carburetor throttle lever.

1. Close fuel shut-off valve.
2. Remove air cleaner outer cover. Then either reposition fuel tank to access governor cross shaft and lever joint, or disconnect fuel line and remove tank from engine.
3. Loosen governor lever mounting nut.
4. CH260, CH270: Move governor lever clockwise until it stops. Rotate governor cross shaft clockwise until it stops.
CH395, CH440: Move governor lever counterclockwise until it stops. Rotate governor cross shaft counterclockwise until it stops.
5. Hold both in this position and torque governor lever nut to 12 N·m (106 in. lb.).

These engines use a splash lubrication system, supplying necessary lubrication to crankshaft, camshaft, connecting rod and valve train components.

Lubrication Components

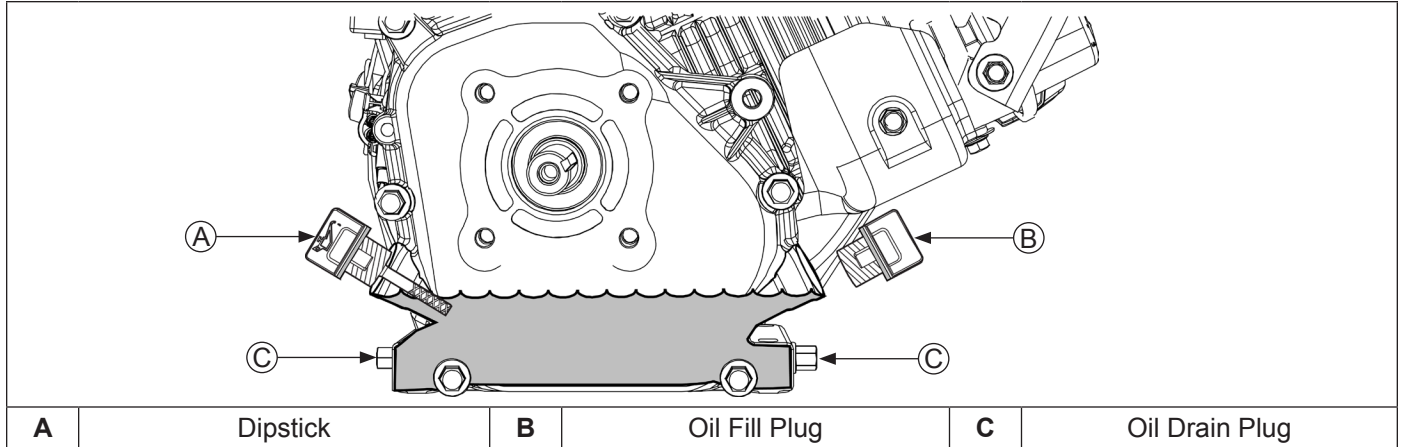

OIL RECOMMENDATIONS

Refer to Maintenance.

CHECK OIL LEVEL

NOTE: To prevent extensive engine wear or damage, never run engine with oil level below or above operating range indicator on dipstick.

Ensure engine is cool and level. Clean oil fill/dipstick areas of any debris.

1. Remove dipstick; wipe oil off.
2. Reinsert dipstick into tube; rest on oil fill neck; turn counterclockwise until cap drops down to lowest point of thread leads; do not thread cap onto tube.
 - a. Remove dipstick; check oil level.

For CH260/CH270 engines, oil level should be at middle of indicator on dipstick.

For all other models, oil level should be at top of indicator on dipstick.

or

 - b. Remove oil fill plug.

For CH260/CH270 engines, oil level should be to middle of filler neck threads.

For all other models, oil level should be up to point of overflowing filler neck.
3. If oil is low, add oil to specified level on dipstick or filler neck threads for engine being serviced. See step 2.
4. Reinstall dipstick or oil fill plug and tighten securely.

CHANGE OIL

Change oil while engine is warm.

1. Clean area around oil fill plug/dipstick and drain plug.
2. Remove drain plug and oil fill plug/dipstick. Drain oil completely.
3. Reinstall drain plug. Torque to 18 N·m (13 ft. lb.).
4. Fill crankcase with new oil to specified level on dipstick or filler neck threads for engine being serviced. See Check Oil Level.
5. Reinstall oil fill plug/dipstick and tighten securely.
6. Dispose of used oil in accordance with local ordinances.

OIL SENTRY™ (if equipped)

This switch is designed to prevent engine from starting in a low oil or no oil condition. Oil Sentry™ may not shut down a running engine before damage occurs. In some applications this switch may activate a warning signal. Read your equipment manuals for more information. For testing procedures refer to Electronic Ignition Systems and Oil Sentry™ Tests.

Electrical System

SPARK PLUGS



CAUTION

Electrical Shock can cause injury.
Do not touch wires while engine is running.

Spark Plug Component and Details

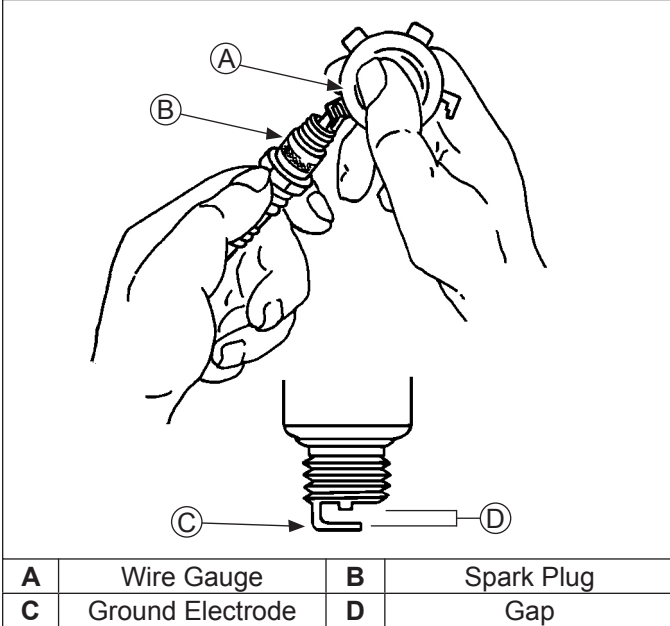

A	Wire Gauge	B	Spark Plug
C	Ground Electrode	D	Gap

NOTE: Do not clean spark plug in a machine using abrasive grit. Some grit could remain in spark plug and enter engine causing extensive wear and damage.

Engine misfire or starting problems are often caused by a spark plug that has improper gap or is in poor condition.

Engine is equipped with following spark plugs:

	CH245, CH255	CH260-CH440
Gap	0.76 mm (0.030 in.)	0.76 mm (0.030 in.)
Thread Size	12 mm	14 mm
Reach	19.1 mm (3/4 in.)	19.1 mm (3/4 in.)
Hex Size	18 mm (3/4 in.)	15.9 mm (5/8 in.)

Refer to Maintenance for Repairs/Service Parts.

Service

Clean out spark plug recess. Remove plug and replace.

1. Check gap using wire feeler gauge. Adjust gap to 0.76 mm (0.030 in.).
2. Install plug into cylinder head.
3. Torque plug to 27 N·m (20 ft. lb.).

Inspection

Inspect each spark plug as it is removed from cylinder head. Deposits on tip are an indication of general condition of piston rings, valves, and carburetor.

Normal and fouled plugs are shown in following photos:

Normal



Plug taken from an engine operating under normal conditions will have light tan or gray colored deposits. If center electrode is not worn, plug can be set to proper gap and reused.

Worn



On a worn plug, center electrode will be rounded and gap will be greater than specified gap. Replace a worn spark plug immediately.

Wet Fouled



A wet plug is caused by excess fuel or oil in combustion chamber. Excess fuel could be caused by a restricted air cleaner, a carburetor problem, or operating engine with too much choke. Oil in combustion chamber is usually caused by a restricted air cleaner, a breather problem, worn piston rings, or valve guides.

Carbon Fouled



Soft, sooty, black deposits indicate incomplete combustion caused by a restricted air cleaner, over rich carburetion, weak ignition, or poor compression.

Overheated



Chalky, white deposits indicate very high combustion temperatures. This condition is usually accompanied by excessive gap erosion. Lean carburetor settings, an intake air leak, or incorrect spark timing are normal causes for high combustion temperatures.

BATTERY

A 12 volt battery (not furnished) with a minimum current rating of 230 cold cranking amps/18 amp hours should be sufficient for cranking most electric start engine models. Actual cold cranking requirement depends on engine size, application, and starting temperatures. Cranking requirements increase as temperatures decrease and battery capacity shrinks. Refer to equipment's operating instructions for specific battery requirements.

If battery charge is insufficient to turn over engine, recharge battery.

Battery Maintenance

Regular maintenance is necessary to prolong battery life.

Battery Test

To test battery, follow manufacturer's instructions.

ELECTRONIC IGNITION SYSTEM

Inductive Discharge Ignition System



A	Ignition Module	B	Magnet
C	Air Gap 0.252 mm (0.010 in.)	D	Kill Switch/Off Position of Key Switch
E	Flywheel	F	Ignition Module (Enlarged View)
G	Spark Plug	H	Spark Plug Boot
I	Spark Plug Terminal	J	Lamination
K	Kill Terminal		

These engines are equipped with a dependable magneto breakerless ignition. In such a system, electrical energy is generated by cutting of magnetic flux lines generated from ignition magnet on engine flywheel via prescribed air gap as it passes ignition module. This energy is transferred through ignition module laminations and is then converted in module electronics and stored in module primary coil, as a current. Stored energy is transferred at correct moment by triggering a semiconductor switch inside module. Electrical break by switch initiates energy transfer by causing collapse of magnetic field at coil primary. This includes a voltage at coil primary that is amplified via transformer action at coil secondary. Amplitude of voltage at coil secondary is sufficient to jump gap at spark plug, igniting fuel air mixture in gap and initiating combustion. Note that by design, these modules only will provide proper function if mounted in correct orientation.

This ignition system is designed to be trouble free for life of engine. Other than periodically checking/replacing spark plugs, no maintenance or timing adjustments are necessary or possible. Mechanical systems do occasionally fail or break down. Refer to Troubleshooting to determine root of a reported problem.

Reported ignition problems are most often due to poor connections. Before beginning test procedure, check all external wiring. Be certain all ignition-related wires are connected, including spark plug leads. Be certain all terminal connections fit snugly. Make sure ignition switch is in run position.

Electrical System

Electronic Ignition Systems and Oil Sentry™ Tests

1. Disconnect cap from spark plug and attach it to terminal end of spark tester. Attach tester spring clip to a good ground, not to spark plug. Turn ignition/key switch ON and crank engine while observing firing tip of tester.

Condition	Conclusion
Tester is firing.	Ignition system is good. Install a new spark plug and try to start engine. If it still will not start, check other possible causes (fuel, compression, etc.).
Tester doesn't fire.	Go to step 2.

2. On electric start engines, remove starter cover panel. Locate black/white kill lead coming from ignition module inside blower housing. Disconnect bullet connector where kill lead plugs into harness. Repeat spark test (step 1).

Condition	Conclusion
Spark is now present.	Check for a shorted lead in kill circuit or a faulty switch (step 7).
Still no spark.	Go to step 3.

3. Disconnect bullet connector where Oil Sentry™ control module joins lead from Oil Sentry™ float switch (yellow leads). Repeat spark test again.

Condition	Conclusion
Spark is now present.	Control module or float switch is faulty. Test control module (step 4) and float switch (step 5). If there is still no spark, test ignition module (step 6).

4. Set an ohmmeter to Rx1 scale and zero meter. Connect black ohmmeter lead to yellow Oil Sentry™ control module lead and touch red ohmmeter lead to black wire.

Condition	Conclusion
Continuity should be indicated.	Replace Oil Sentry™ control module for any other results.

5. With crankcase oil at proper level, set an ohmmeter to Rx1 scale and zero meter. Connect one ohmmeter lead to Oil Sentry™ float switch lead (yellow with green sleeve) and touch other lead to a bare spot on crankcase (ground).

Condition	Conclusion
If continuity is indicated.	Replace float switch.
If no continuity is indicated.	Go to step 6.

6. Set an ohmmeter to Rx1K or Rx10K scale and zero.
 - a. Connect one ohmmeter lead to kill lead (black/white) terminal and connect other lead into spark plug cap. Resistance should be 13.5-18.0 K ohms. If resistance is other than specified, go to b.
 - b. Remove blower housing and remove ignition module. With kill lead removed, test resistance from small spade terminal to spark plug cap. Resistance should be 9.5-12.9 K ohms. If resistance is not in this range, replace ignition module.
7. Set an ohmmeter to Rx1 scale and zero meter. Test ignition/key switch as follows.
 - a. Trace two black leads from on/off switch and separate them from any connections. Connect ohmmeter leads to switch leads, and check for continuity in both switch positions.

Condition	Conclusion
Continuity should be indicated when and only when switch is in OFF position.	Replace switch for any other results.

- b. On electric start engines, trace four leads (red, red/white, black, black/white) from key switch and separate them from any connections. Connect ohmmeter leads to black and black/white leads and check for continuity in all three switch positions. Then connect ohmmeter leads to red and red/white leads and test again in all three switch positions.

Condition	Conclusion
Continuity should be indicated between black and black/white leads only when key switch is in OFF position. There should be continuity between red and red/white leads only in start position.	Replace switch for any other results.

BATTERY CHARGING SYSTEMS

CH245, CH255 Wiring Diagram-Retractable Starter

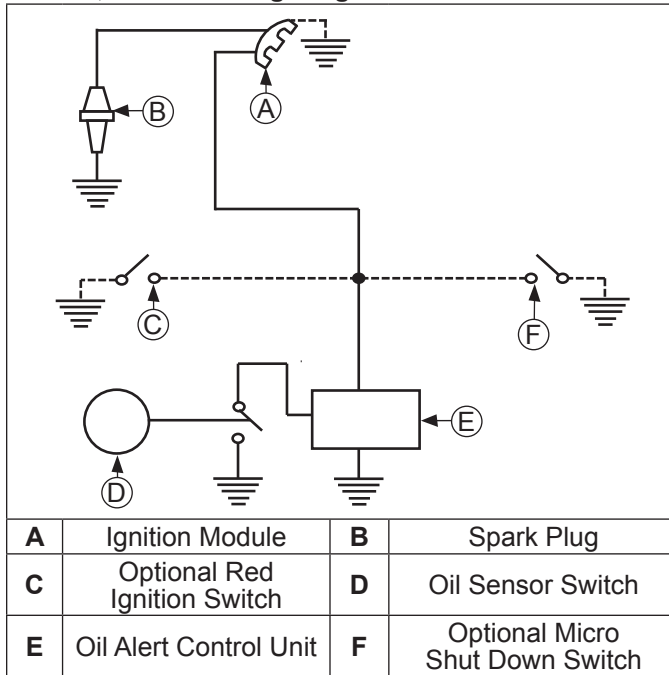

CH260-CH440 Wiring Diagram-Retractable Starter

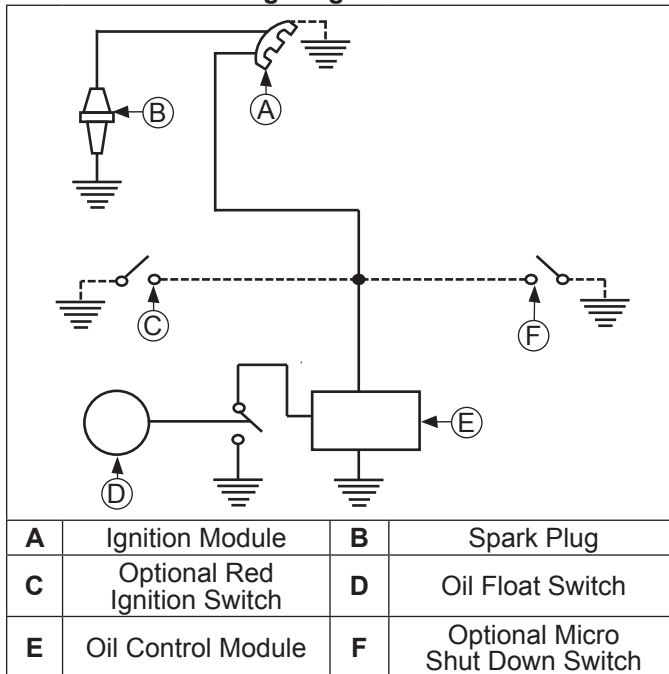

NOTE: Observe following guidelines to avoid damage to electrical system and components:

- Make sure battery polarity is correct. A negative (-) ground system is used.
- Make sure all ground connections are secure and in good condition.
- Disconnect both battery cables before doing electrical welding on equipment powered by engine. Also, disconnect other electrical accessories in common ground with engine.
- Prevent stator (AC) leads from touching or shorting while engine is running. This could damage stator.

Most engines are equipped with a 3,4,10, or 18 amp regulated battery charging system.

3/4/10/18 Amp Regulated Charging System

Stator

Stator is mounted on crankcase behind flywheel. Should stator have to be replaced, follow procedures in Disassembly.

Rectifier-Regulator

Rectifier-Regulator Receptacle

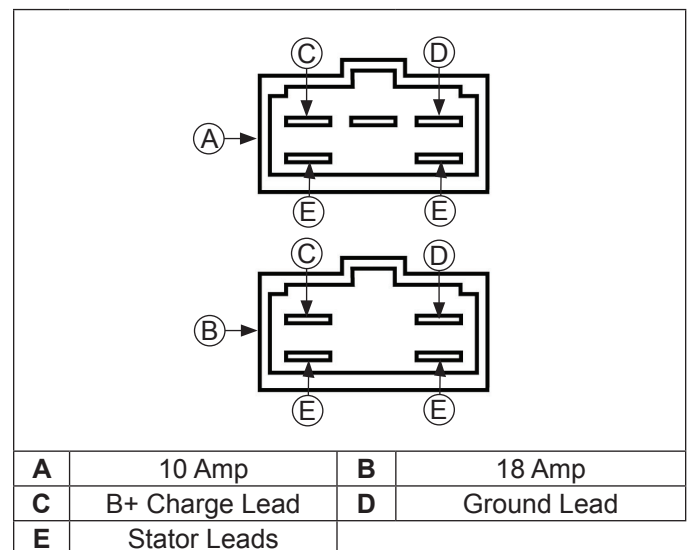

NOTE: When installing rectifier-regulator, push wiring harness plug into regulator receptacle until it locks into place.

Rectifier-regulator is connected to engine with a matching wiring harness containing a plug-in connector. Grounded through wiring harness, rectifier-regulator is secured to equipment in a suitable location with two mounting screws. To replace it, disconnect plug, and remove two mounting screws.

Rectifier-regulator converts AC voltage coming from stator to DC voltage, while also monitoring and controlling battery voltage. There are two different rectifier-regulators which are used; an 18 amp and a 10 amp assembly. Although externally similar, internal circuits differ and two should not be interchanged.

Electrical System

Rectified Only (non-regulated) Systems

Some engines are equipped with a rectified only, non-regulated charging system, with output ranging from 3 amps to 4 amps. Rectifier is normally connected to engine with a matching wiring harness and secured inside control panel. Grounding is achieved through wiring harness. Rectifier converts AC voltage coming from stator to DC voltage only.

Wiring Diagram-3/4 Amp Charging System, Rectified Only

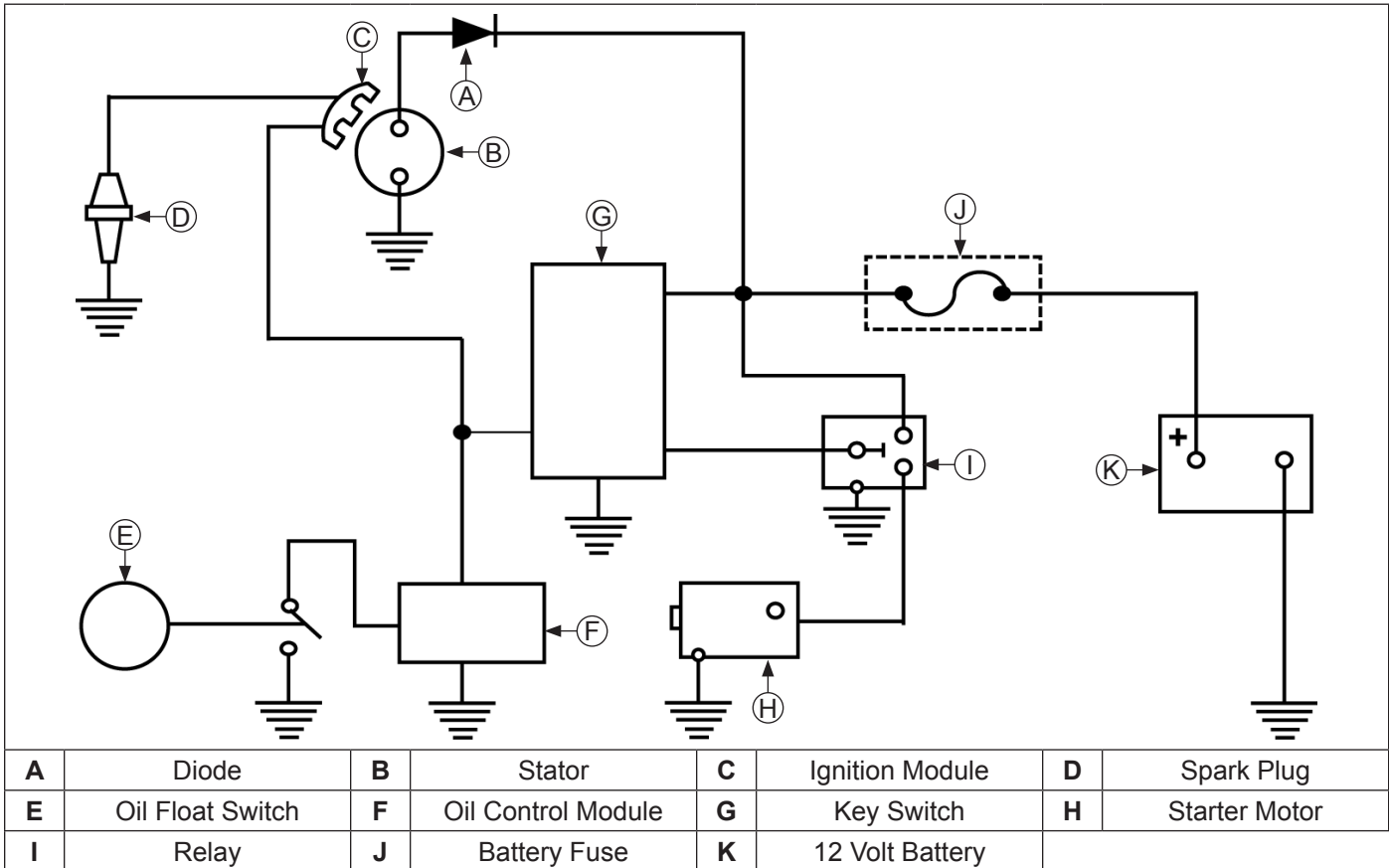

3/4/10/18 Amp Battery Charging Systems

NOTE: Zero ohmmeters on each scale to ensure accurate readings. Voltage tests should be made with engine running at 3600 RPM - no load. Battery must be fully charged. Check specific gravity of battery. If low, recharge or replace battery as necessary.

To test charging system for no charge to battery:

1. Separate bullet connector in white lead from rectifier-regulator. Connect an ammeter from female terminal to positive (+) terminal of battery. Connect a DC voltmeter from female terminal to negative (-) terminal of battery. Leave other rectifier-regulator leads connected in normal manner. Run engine at 3600 RPM and read voltage on voltmeter.

If voltage is 14.0 volts or more, place a minimum load of 5 amps (turn on lights if 60 watts or more, or place a 2.5 ohm, 100 watt resistor across battery terminals) on battery to reduce voltage. Observe ammeter.

Condition	Conclusion
Voltage is 14.0-15.0 volts and charge rate increases when load is applied.	Charging system is OK and battery was fully charged.
Voltage is less than 14.0 volts or charge rate does not increase when load is applied.	Test stator (steps 2 and 3).

2. Separate bullet connectors in AC (white) leads. Connect an AC voltmeter across stator leads (female terminals). With engine running at 3600 RPM, measure AC output from stator.

Condition	Conclusion
Voltage is 20.0 volts or more.	Stator is OK. Rectifier-regulator is faulty; replace.
Voltage is less than 20.0 volts.	Stator is probably faulty and should be replaced. Test stator further using an ohmmeter (step 3).

3. With engine stopped, measure resistance from each stator lead to ground using an ohmmeter.

Condition	Conclusion
Resistance is infinity ohms (no continuity).	Stator is OK (not shorted to ground).
Resistance (or continuity) is measured.	Stator leads are shorted to ground; replace.

To test charging system for battery continuously charging at high rate:

1. Separate bullet connector in white lead from rectifier-regulator. Connect an ammeter from female terminal to positive (+) terminal of battery. Connect a DC voltmeter from female terminal to negative (-) terminal of battery. Leave other rectifier-regulator leads connected in normal manner. Run engine at 3600 RPM and read voltage on voltmeter.

If voltage is 14.0 volts or more, place a minimum load of 5 amps (turn on lights if 60 watts or more, or place a 2.5 ohm, 100 watt resistor across battery terminals) on battery to reduce voltage. Observe ammeter.

Condition	Conclusion
Voltage is 15.0 volts or less.	Charging system is OK. Battery is unable to hold a charge; service or replace.
Voltage is more than 15.0 volts.	Faulty rectifier-regulator; replace.

Electrical System

Wiring Diagram-10/18 Amp Charging System, with Rectifier-Regulator

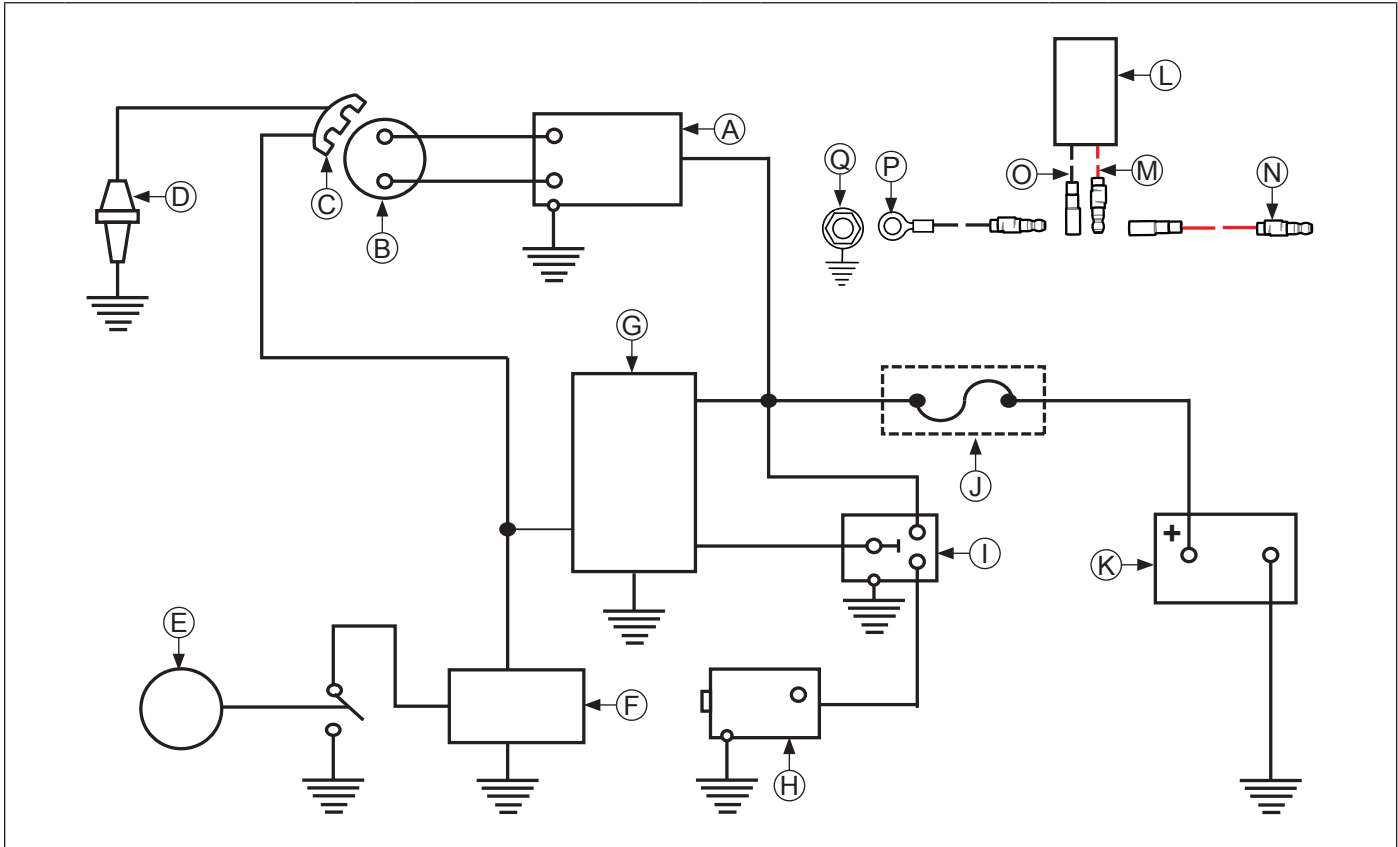

A	Rectifier-Regulator	B	Stator	C	Ignition Module	D	Spark Plug
E	Oil Float Switch	F	Oil Control Module	G	Key Switch	H	Starter Motor
I	Relay	J	Battery Fuse	K	12 Volt Battery	L	Fuel Shut-off Solenoid (if equipped)
M	Red Solenoid Lead (if equipped)	N	Red Solenoid Lead To Application (if equipped)	O	Black Solenoid Lead (if equipped)	P	Black Solenoid Ground Lead (if equipped)
Q	Ignition Module Fastener (if equipped)						

NOTE: Do not crank engine continuously for more than 10 seconds. Allow a 60 second cool down period between starting attempts. Failure to follow these guidelines can burn out starter motor.

NOTE: If engine develops sufficient speed to disengage starter but does not keep running (a false start), engine rotation must be allowed to come to a complete stop before attempting to restart engine. If starter engages while flywheel is rotating, starter pinion and flywheel ring gear may clash and damage starter.

NOTE: If starter does not crank engine, shut off starter immediately. Check condition of inline fuse and do not make further attempts to start engine until condition is corrected.

NOTE: Do not drop starter or strike starter housing. Doing so can damage starter.

Engines in this series use inertia drive electric starters or retractable starters. CH245, CH255, CH270 inertia drive electric starters are not serviceable.

Troubleshooting-Starting Difficulties

Condition	Possible Cause	Conclusion
Starter does not energize.	Battery	Check specific gravity of battery. If low, recharge or replace battery as necessary.
	Wiring	Check fuse condition. Clean corroded connections and tighten loose connections. Replace wires in poor condition and with frayed or broken insulation.
	Starter Switch or Solenoid	Check switch or relay operation. If starter cranks normally, replace faulty components.
Starter energizes but turns slowly.	Battery	Check specific gravity of battery. If low, recharge or replace battery as necessary.
	Wiring	Check for corroded connections, poor ground connection.
	Transmission or Engine	Make sure clutch or transmission is disengaged or placed in neutral. This is especially important on equipment with hydrostatic drive. Transmission must be exactly in neutral to prevent resistance which could keep engine from starting. Check for seized engine components such as bearings, connecting rod, and piston.

Electric Starting System Tests

1. Test battery on unit.
 - a. Connect a DC voltmeter across battery terminals and read battery voltage (key switch OFF).
 - b. Turn key switch to start position and read battery voltage again. Turn switch OFF.

Condition	Conclusion
Voltage less than 12 volts.	Charge battery.
Battery voltage should not fall below 9 volts during cranking.	If it does, battery may be faulty or there may be a short in starting circuit. Have battery load tested. If battery passes load test, check circuitry.

2. Remove electric starter cover panel and check fuse inside plastic holder. Fuse outside holder is a spare.

Condition	Conclusion
Fuse is blown.	Check for a wiring problem (bare wire, short circuit). Correct problem and replace fuse. Try to start engine. If it still won't start, go to step 3.

3. Disconnect blue relay lead. Be sure transmission is in neutral and PTO is OFF. Connect one end of a jumper lead to positive terminal of battery. Connect other end to terminal of relay.

Condition	Conclusion
Relay engages and starter begins to crank.	Key switch is faulty, or there is a wiring problem to/from key switch. Check wiring and test key switch circuits with an ohmmeter.

Starter System

4. Use a known, good, fully-charged battery and jumper cables to test starter motor. Be sure transmission is in neutral and PTO is OFF.
- Remove heavy lead from post terminal on starter. Connect one end of positive jumper cable to post terminal and connect other end to positive terminal of battery.
- Connect one end of negative jumper cable to negative terminal of battery. Touch other end of negative jumper cable to a bare surface on crankcase or to starter housing.

Condition	Conclusion
Relay engages and starter begins to crank.	Key switch is faulty, or there is a wiring problem to/from key switch. Check wiring and test key switch circuits with an ohmmeter.

5. Disconnect leads from starter relay and remove it from starter for testing.
- a. Set an ohmmeter on Rx1 scale and zero meter. Connect one ohmmeter lead to terminal of blue lead from relay. Connect other ohmmeter lead to relay mounting bracket.

Condition	Conclusion
Meter reading less than 3.4 ohms, or an open circuit is indicated (infinity ohms).	Relay is faulty and must be replaced.

- b. With ohmmeter still on Rx1 scale, connect leads to two large post terminals. Meter should indicate an open circuit (infinity ohms, no continuity).
- c. Leave ohmmeter leads connected to large terminals. Connect a jumper lead from positive terminal of battery to terminal of blue relay lead. Connect another jumper lead from negative terminal of battery to relay mounting bracket.

Condition	Conclusion
When circuit is completed, applying 12 volts to energizing coil, an audible click should be heard as relay engages, and ohmmeter should then indicate continuity between large terminals.	Results are other than indicated, replace relay.

INERTIA DRIVE ELECTRIC STARTERS

	⚠ WARNING
	<p>Accidental Starts can cause severe injury or death.</p> <p>Disconnect and ground spark plug lead(s) before servicing.</p>
<p>Before working on engine or equipment, disable engine as follows: 1) Disconnect spark plug lead(s). 2) Disconnect negative (-) battery cable from battery.</p>	

Type I Starter CH395, CH440

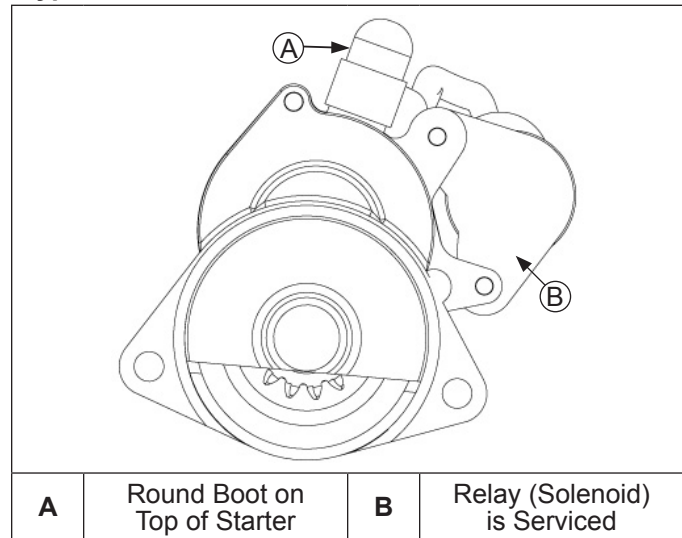

Type II Starter CH440

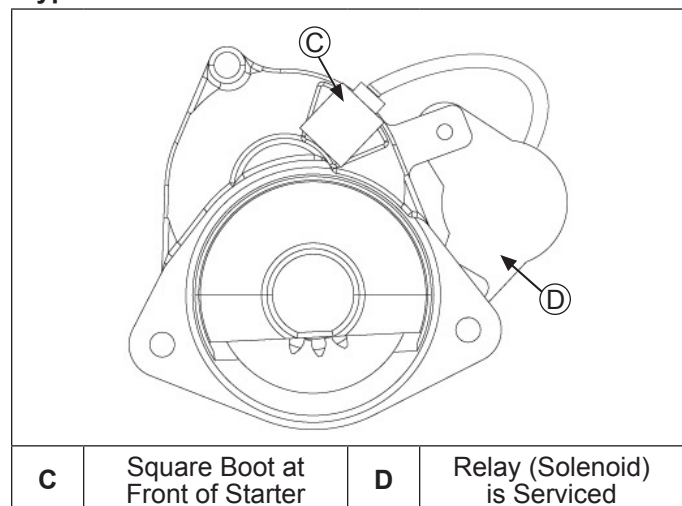

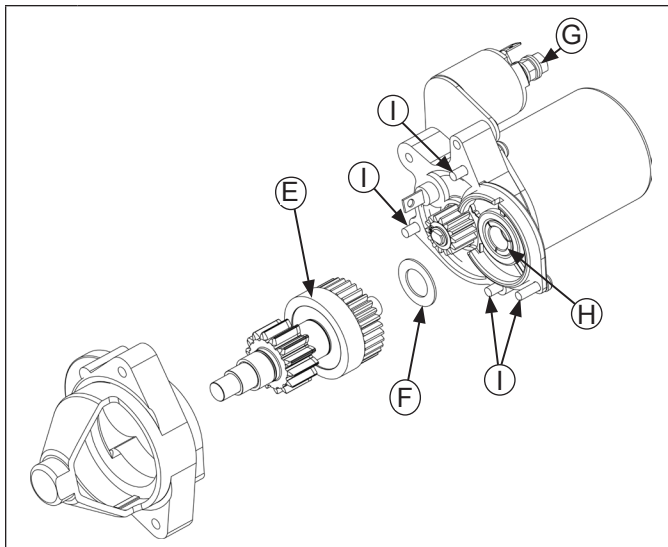

E	Drive Assembly is Serviced	F	Shim
G	Relay (Solenoid) Nuts	H	Motor to Starter Drive Assembly
I	Four Screws		

Relay (Solenoid) Replacement CH395, CH440

1. Disconnect all lead wires from relay (solenoid). Note location for reassembly.
2. Remove screws securing relay (solenoid), and remove relay (solenoid) from starter assembly.
3. Install new relay (solenoid) to starter assembly and secure with screws. Torque screws to 3.2 N·m (28 in. lb.).
4. Reconnect all lead wires to relay (solenoid). Torque nuts to 4.5 N·m (40 in. lb.).

Drive Replacement CH440 Type II Starter

NOTE: If access is available to remove screws (4) and separate drive end from motor gear end, starter removal is not necessary. If access is not available, remove starter assembly from engine.

1. Disconnect all lead wires from starter. Note location of each for reassembly.
2. Move square boot to access and remove brush lead connector wire screw.
3. Remove 4 screws and separate starter.
4. Remove drive assembly and retain shim.
5. Lubricate motor to drive assembly gears with Rehlko starter drive lubricant.
6. Install shim on motor side of new drive assembly.
7. Reassemble starter components in reverse order. Torque 4 screws to 5.8 N·m (51 in. lb.). Torque brush lead connector wire screw to 1.7 N·m (15 in. lb.).
8. If starter assembly was removed from engine, reinstall and torque mounting screws to 24 N·m (212 in. lb.).

Starter System

RETRACTABLE STARTERS

	⚠ WARNING	Retractable starters contain a powerful, recoil spring that is under tension. Always wear safety goggles when servicing retractable starters and carefully follow instructions in Retractable Starter for relieving spring tension.
	Uncoiling Spring can cause severe injury. Wear safety goggles or face protection when servicing retractable starter.	

Retractable Starter Components

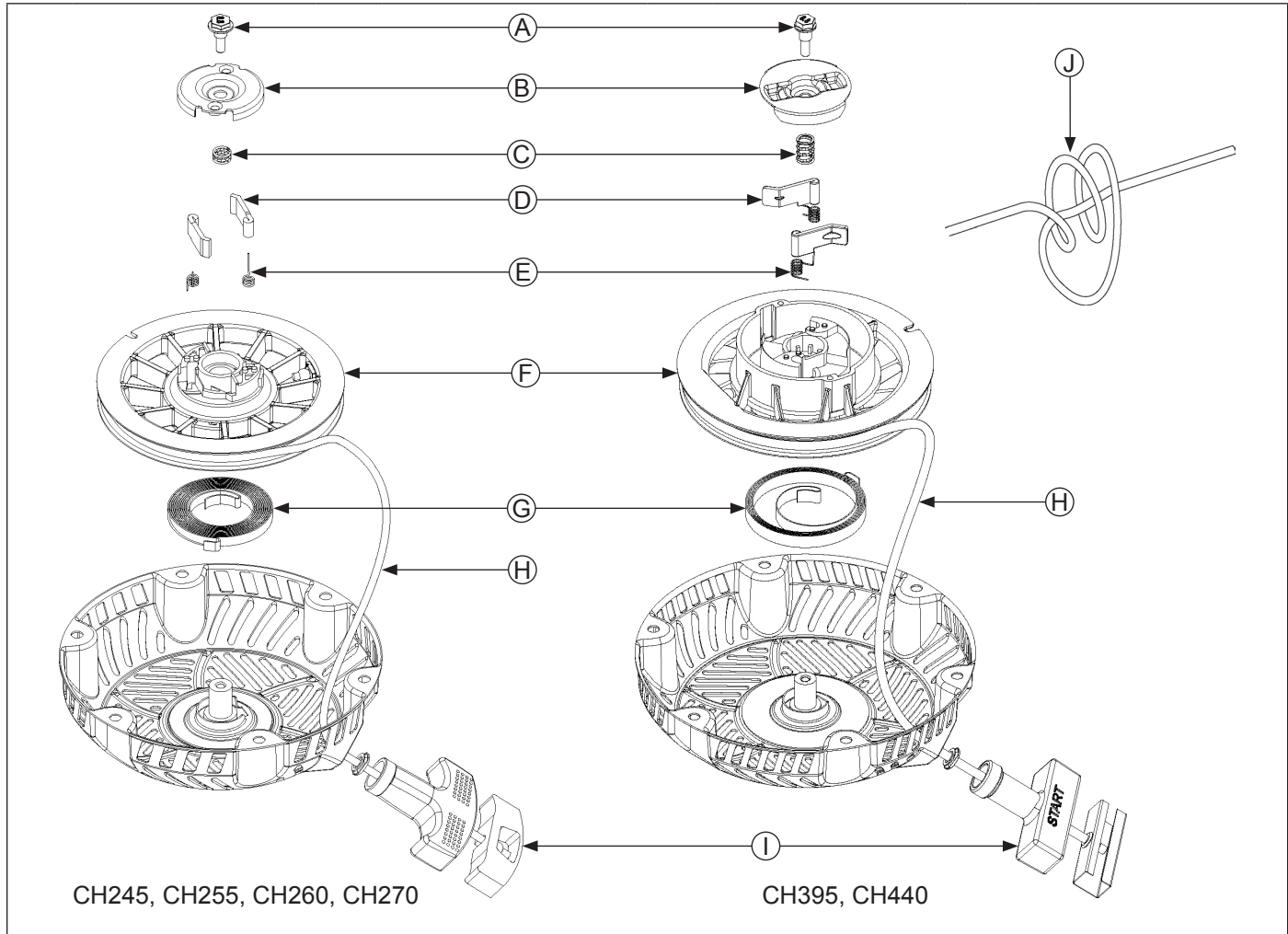

A	Center Screw	B	Drive Plate	C	Friction Spring	D	Drive Pawl (Dogs)
E	Drive Pawl Springs	F	Pulley	G	Recoil Spring	H	Starter Rope
I	Starter Handle	J	Double Left-Hand Knot				

Remove Starter

1. Remove screws securing starter to blower housing.
2. Remove starter assembly.

Rope Replacement

NOTE: Do not allow pulley/spring to unwind. Enlist aid of a helper if necessary.

Rope can be replaced without complete starter disassembly.

1. Remove starter assembly from engine.
2. Pull rope out approximately 12 in. and tie a temporary (slip) knot in it to keep it from retracting into starter.
3. Pull knot end out of handle, untie knot, and slide handle off.
4. Hold pulley firmly and untie slipknot. Allow pulley to rotate slowly as spring tension is released.
5. When all spring tension on starter pulley is released, remove rope from pulley.
6. Tie a double left-hand knot in one end of new rope.
7. Rotate pulley counterclockwise to pre-tension spring (approximately 4 full turns of pulley).
8. Continue rotating pulley counterclockwise until rope hole in pulley is aligned with rope guide bushing of starter housing.
9. Insert unknotted end of new rope through rope hole in starter pulley and rope guide bushing of housing.
10. Tie a slipknot approximately 12 in. from free end of rope. Hold pulley firmly and allow it to rotate slowly until slipknot reaches guide bushing of housing.
11. Insert starter rope through starter handle and tie a double, left-hand knot at end of starter rope. Insert knot into hole in handle.
12. Untie slip knot and pull on starter handle until starter rope is fully extended. Slowly retract starter rope into starter assembly. If recoil spring is properly tensioned, starter rope will retract fully and starter handle will stop against starter housing.

Pawls (dogs) Replacement

1. Install a clamp to hold pulley in starter housing and prevent it from rotating.
2. Unscrew center screw and lift off drive plate.
3. Note positions of pawls and pawl springs before removing. Remove parts from pulley.
4. Install pawl springs and pawls into pawl slots of pulley. All parts must be dry.
5. Position drive plate over pawls, aligning actuating slots in place with raised sections on each drive pawl. Torque center screw to 5-6 N·m (44-54 in. lb.).
6. Remove clamp and pull starter rope out part way to check operation of pawls.

Install Starter

1. Install retractable starter onto blower housing leaving screws slightly loose.
2. Pull starter handle out until pawls engage in drive cup. Hold handle in this position and tighten screws securely.

Gear Reduction System

	⚠ WARNING	Before working on engine or equipment, disable engine as follows: 1) Disconnect spark plug lead(s). 2) Disconnect negative (-) battery cable from battery.
	Accidental Starts can cause severe injury or death. Disconnect and ground spark plug lead(s) before servicing.	

Some engines are equipped with either a 6:1 or a 2:1 gear reduction system.

- 6:1 Gear reduction system reduces PTO shaft RPM by 6:1; crankshaft turns 6 times to 1 time of PTO shaft.
- 2:1 Gear reduction system reduces PTO shaft RPM by 2:1; crankshaft turns 2 times to 1 time of PTO shaft.

CH245, CH255, CH270 6:1 Gear Reduction System

Components

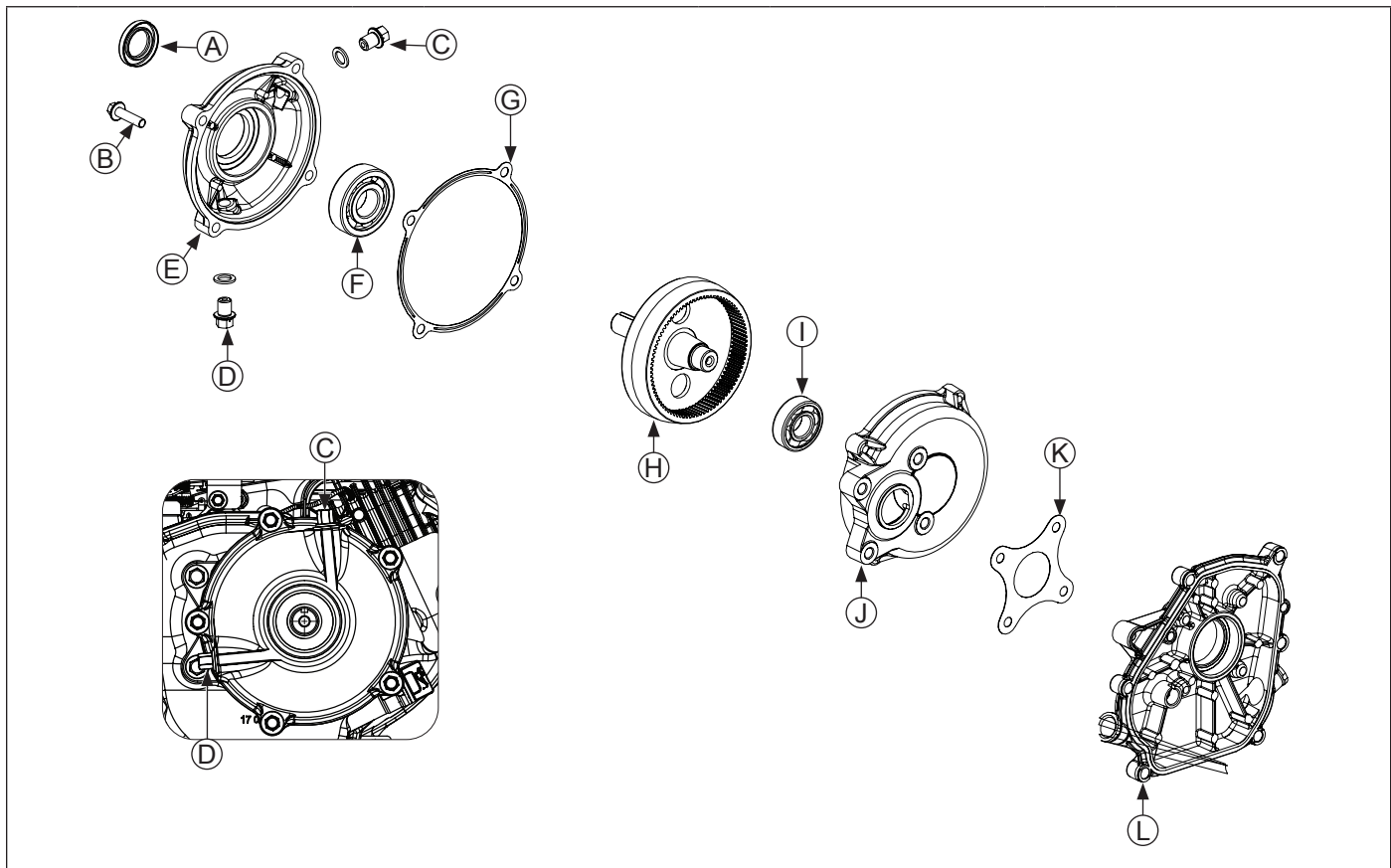

A	Oil Seal	B	Screw	C	Oil Fill Plug	D	Oil Level/Drain Plug
E	Reduction Cover	F	Reduction Cover Bearing	G	Reduction Cover Gasket	H	PTO Shaft
I	Inner PTO Support Bearing	J	Reduction Case	K	Reduction Case Gasket	L	Closure Plate

Gear Reduction System

This reduction system uses an internal pinion and ring gear system, independent of, and separated from main crankcase lubrication. Check and maintain oil level using oil level/drain plug hole in gear box (reduction) case. Change reduction system oil at interval in maintenance schedule (see Maintenance). Oil capacity of this gear box is 0.12 L (0.13 U.S. qt.).

Disassembly

NOTE: Place a drain pan under gear reduction unit to catch any residual oil when cover is removed. Dispose of used oil in accordance with local ordinances.

NOTE: Note orientation of cover and fill and level plug positions.

NOTE: Bearings in housings may be removed if necessary using a bearing puller.

NOTE: Earlier reduction cover and gasket secure with 5 screws, later design cover and gasket secure with 4 screws.

1. Remove key from reduction assembly PTO shaft. Clean shaft and keyway of any burrs/damage.
2. Remove reduction oil/level drain plug and drain oil into suitable container.
3. Remove screws securing reduction cover to reduction case. Note position of cover.

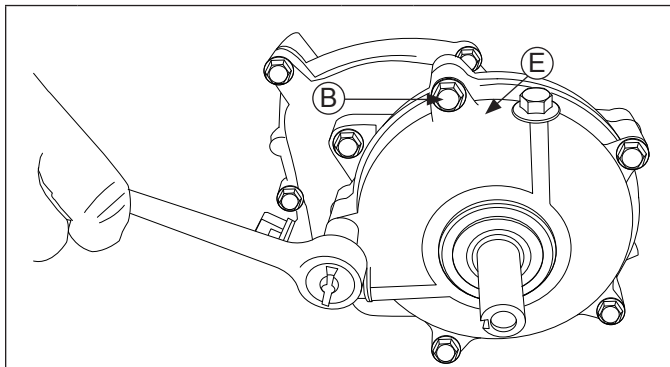

B	Screw	E	Reduction Cover
----------	-------	----------	-----------------

4. Remove reduction cover and gasket from reduction case.

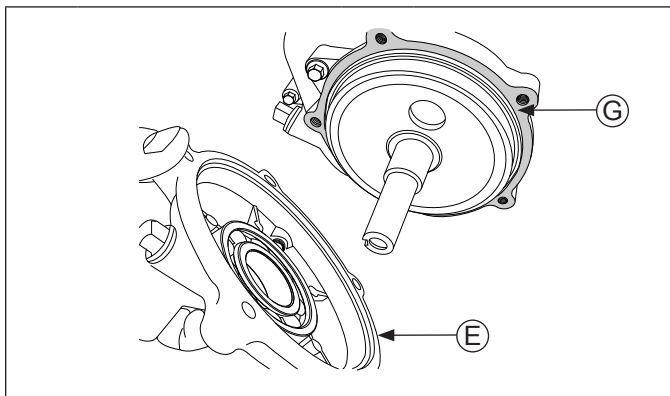

E	Reduction Cover	G	Reduction Cover Gasket
----------	-----------------	----------	------------------------

5. Remove PTO shaft from reduction case.

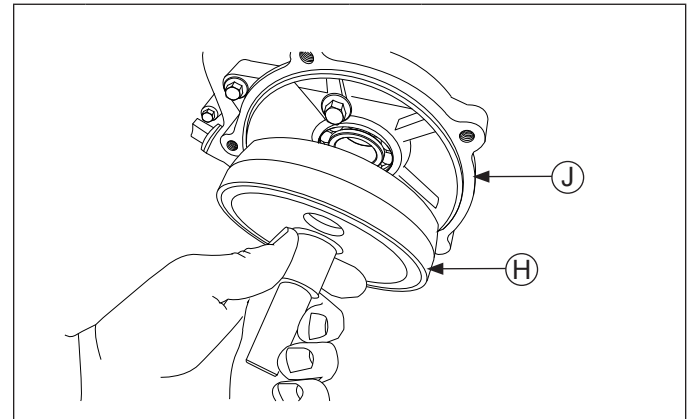

H	PTO Shaft	J	Reduction Case
----------	-----------	----------	----------------

6. If reduction case requires removal from closure plate, remove mounting screws.

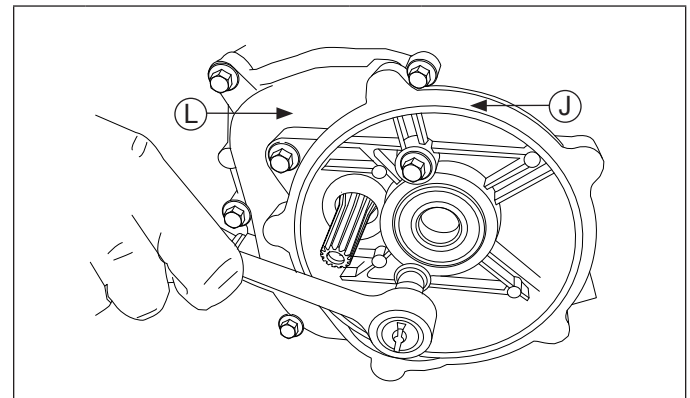

J	Reduction Case	L	Closure Plate
----------	----------------	----------	---------------

7. Carefully separate reduction case from closure plate.

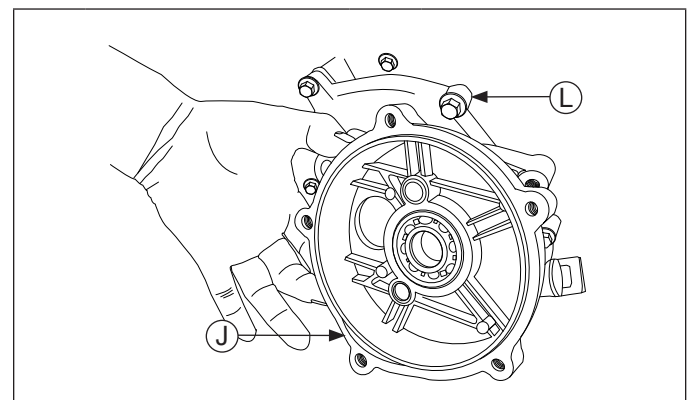

J	Reduction Case	L	Closure Plate
----------	----------------	----------	---------------

Gear Reduction System

8. Remove reduction case gasket between reduction case and closure plate. Clean all gasket surfaces.

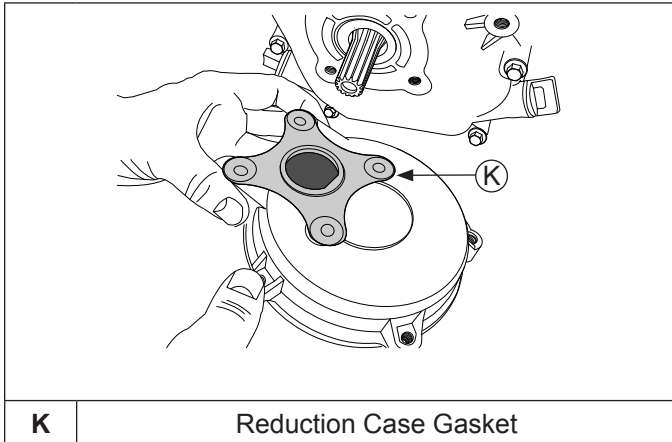

Inspection

Remove all gaskets and clean all gasket surfaces. Do not nick or damage surfaces. Clean and inspect condition of all gears for any abnormal wear or damage. Replace as necessary. Rotate bearings and check for any roughness. Inspect bearing surfaces for any damage or irregularities. Replace as necessary.

Reassembly

NOTE: Use new gaskets when assembling. Lightly lubricate lip of seal with oil.

NOTE: Lubricate gears with clean oil before assembling.

1. Install new reduction case gasket between reduction case and closure plate.
2. Install reduction case to closure plate and secure with screws. Torque screws to 24.4 N·m (216 in. lb.).
3. Lubricate and install PTO shaft into reduction housing. Engage teeth with splines on crankshaft and slide assembly into bearing bore on housing.
4. Using new reduction cover gasket, install reduction cover. Position outer cover as originally installed and secure with screws. Torque screws to 7.4 N·m (66 in. lb.).
5. Install key into keyway of PTO shaft.
6. Engine must be level. Add new oil through oil fill plug hole on top until oil level is up to bottom of oil level/drain plug hole. Reinstall both plugs and tighten securely.

CH270 2:1 Gear Reduction System

Components

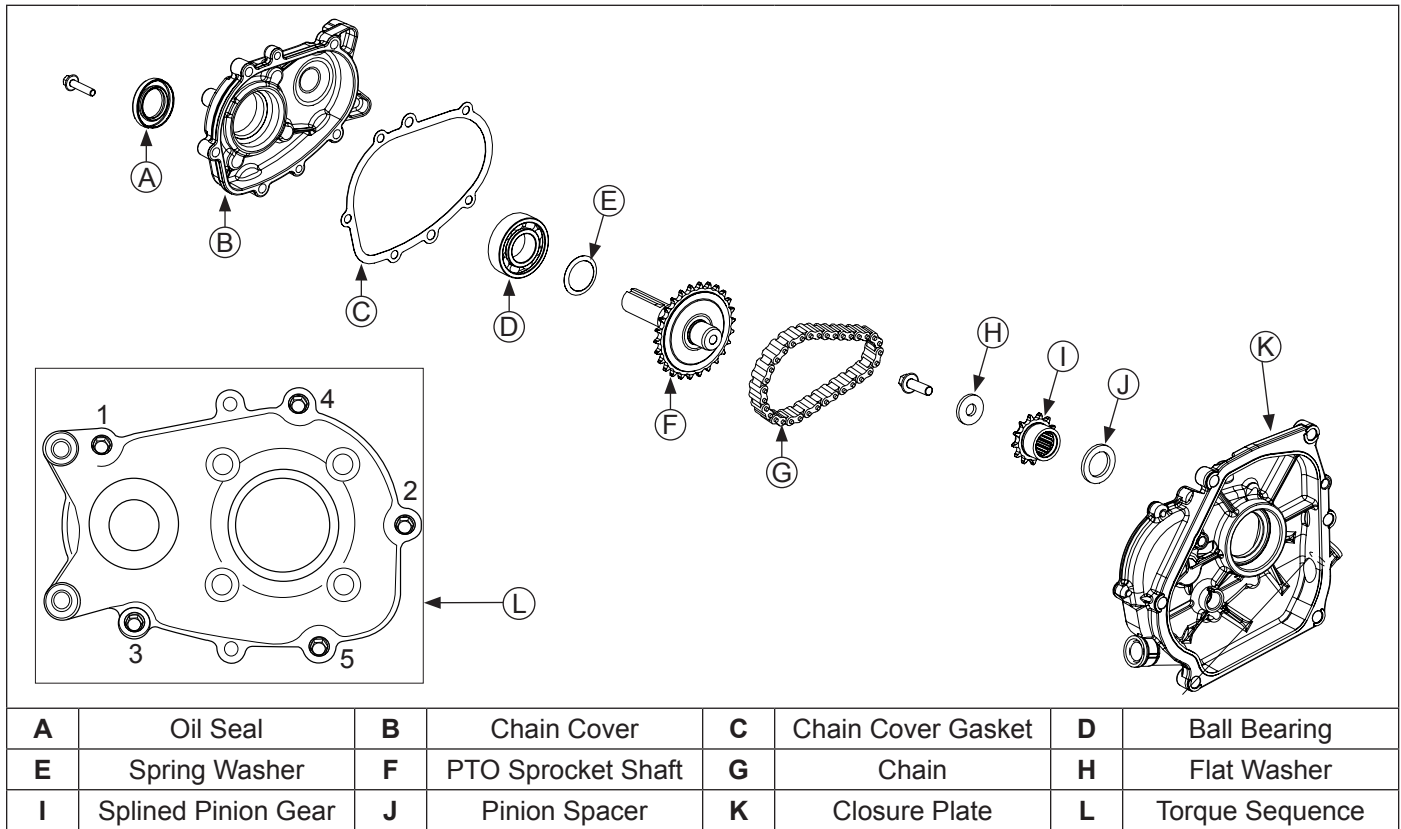

This reduction system is lubricated by engine crankcase oil. No special maintenance or service is necessary. Check and maintain engine oil level as outlined in Check Oil Level (see Lubrication System).

Disassembly

NOTE: Place a drain pan under gear reduction unit to catch any residual oil when cover is removed. Dispose of used oil in accordance with local ordinances.

NOTE: Bearings may be removed if necessary using a bearing puller.

1. Remove engine oil drain plug and drain oil into suitable container.
2. Remove any drive coupling and key from reduction assembly PTO shaft. Clean shaft and keyway of any burrs/damage.

3. Remove screws securing chain cover to closure plate.

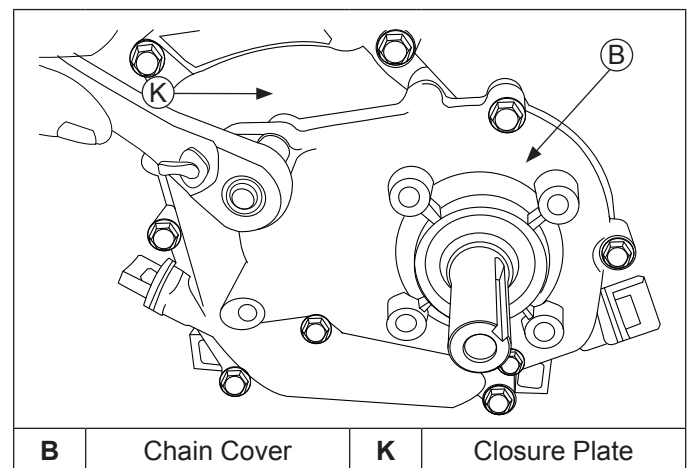

Gear Reduction System

- Remove cover and gasket. Ensure two dowel pins remain in place.

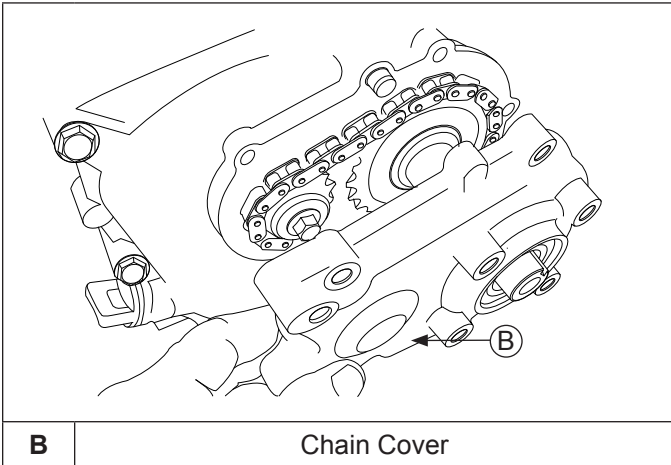

- Remove screw and outer flat washer securing splined pinion gear to crankshaft.

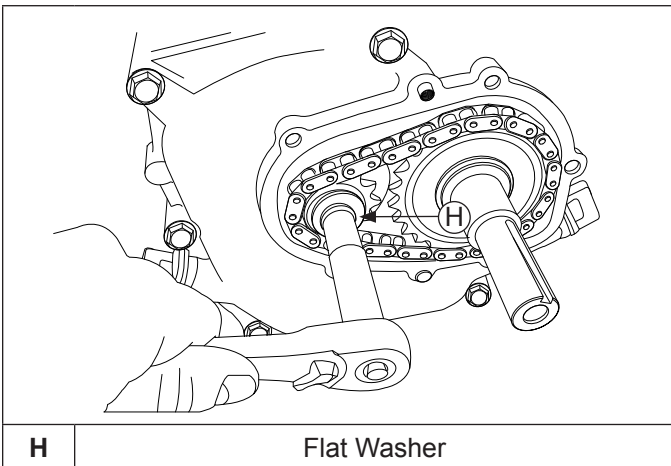

- Carefully remove splined pinion gear, chain, and PTO sprocket shaft with spring washer from unit as an assembly.

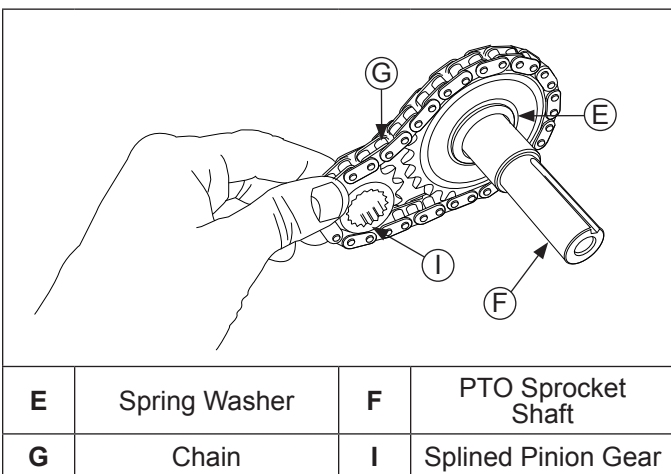

- If necessary, remove rear pinion spacer from crankshaft. Note position of spring washer on outer side of PTO sprocket shaft.

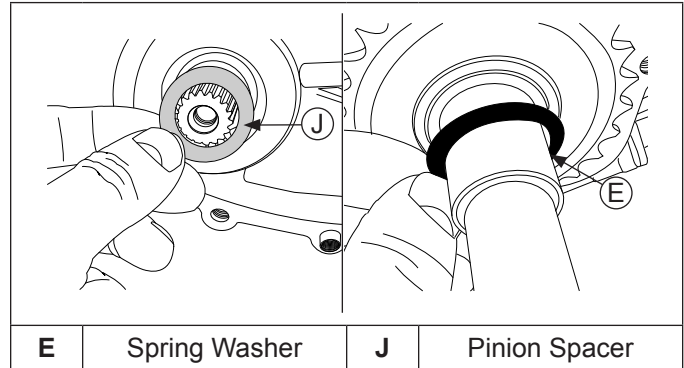

Inspection

Remove gaskets and clean all gasket surfaces. Do not nick or damage surfaces. Clean and inspect condition of all gears and chain for wear, chips, or damage. Replace as necessary. Rotate bearings and chain and check for any roughness. Inspect bearing surfaces for any damage or irregularities. Replace as necessary.

Reassembly

NOTE: Use new gaskets and outer seal when assembling. Lightly lubricate lip of seal with oil.

NOTE: Lubricate chain and gears with clean oil before assembling.

- Ensure spring washer is in correct position on outer side of PTO sprocket shaft.
- If removed, install rear pinion spacer to crankshaft.
- Ensure chain is around PTO sprocket shaft and splined pinion gear. Slide PTO sprocket shaft, chain, and splined pinion gear into reduction unit as an assembly.
- Install outer flat washer to splined pinion gear and secure to PTO shaft with screw. Torque screw to 24.4 N·m (216 in. lb.).
- Using a new chain cover gasket, install chain cover to reduction unit. Secure with screws. Torque screws, in sequence shown, to 7.4 N·m (66 in. lb.).
- Install key into keyway of PTO sprocket shaft.
- Refill engine oil as outlined in Change Oil (see Lubrication System).

CH245, CH255, CH270 2:1 with Clutch Gear Reduction System

Components

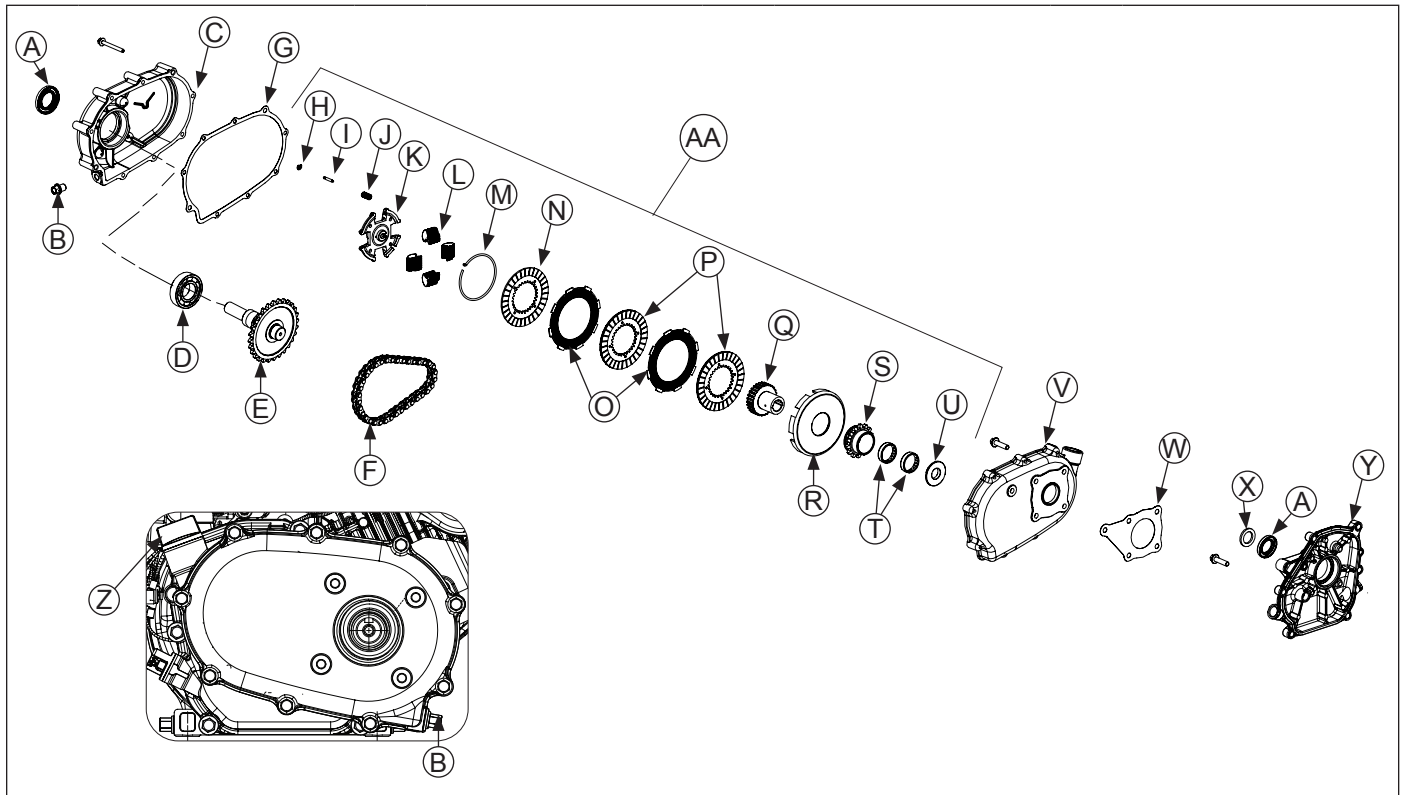

A	Oil Seal	B	Drain Plug	C	Reduction Cover	D	Crankshaft Bearing
E	PTO Shaft	F	Chain	G	Reduction Case Cover Gasket	H	Retainer Ring
I	Weight Holder Pin	J	Clutch Holder Spring	K	Weight Holder	L	Clutch Weight
M	Weight Retainer	N	Pressure Plate	O	Clutch Plate	P	Friction Disc
Q	Clutch Center Gear	R	Clutch Cup	S	Drive Gear	T	Slide Bearing
U	Thrust Washer	V	Reduction Case	W	Reduction Case Gasket	X	Pinion Spacer
Y	Closure Plate	Z	Reduction Case Dipstick	AA	Clutch Assembly		

NOTE: Engines with this reduction system must be operated at 2400 RPM or higher under load, when full gear box engagement occurs. Operating engine under heavy loads below 2400 RPM, could result in clutch/gear box failure from disc slippage/overheating and insufficient engine cooling, not covered under normal warranty.

This reduction system uses a clutch assembly and chain and sprocket drive system, independent of, and separated from main crankcase lubrication. Check and maintain oil level using dipstick in gear box (reduction) case. Change reduction system oil at interval in maintenance schedule (see Maintenance). Use 20W-40 or 20W-50 oil in this gear box (reduction) case. Oil capacity of this gear box is 0.5 L (0.52 U.S. qt.).

Disassembly

NOTE: Place a drain pan under gear reduction unit to catch any residual oil when cover is removed. Dispose of used oil in accordance with local ordinances.

NOTE: Bearings in cover and clutch cup can be removed if necessary using a bearing puller. Crankshaft bearing removal requires closure plate removal. Refer to Disassembly/Inspection and Service for procedure.

1. Remove any drive coupling and key from reduction assembly PTO shaft. Clean shaft and keyway of any burrs/damage.
2. Remove drain plug and reduction case dipstick, and drain oil into suitable container.

Gear Reduction System

- Remove screws securing reduction cover to reduction case.

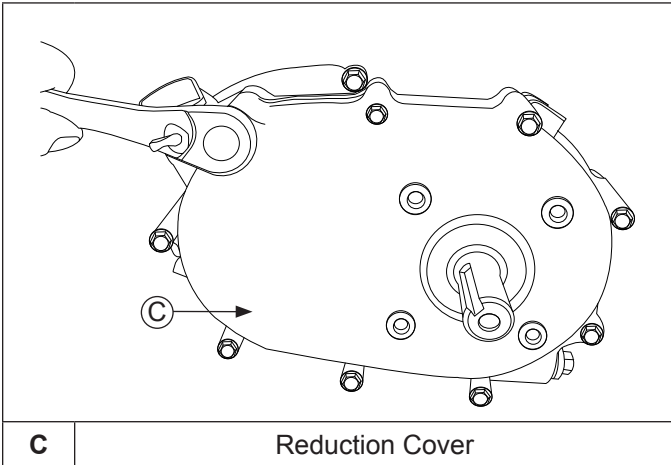

- Remove reduction cover and gasket. Ensure two dowel pins remain in place.
- Remove screw and lock washer securing clutch assembly to crankshaft.

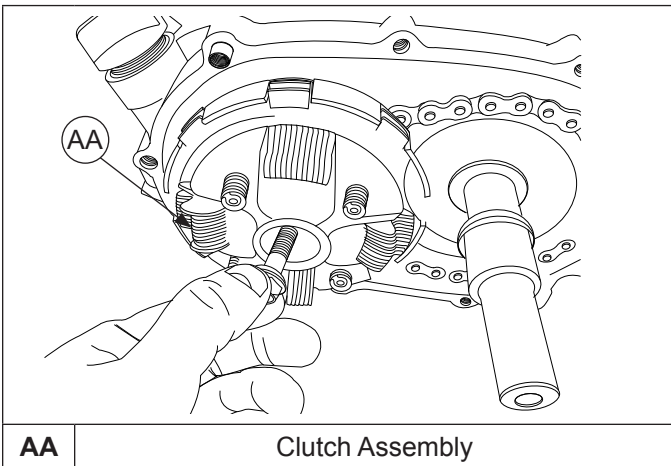

- Carefully remove clutch assembly, chain, and PTO shaft with spring washer from unit as an assembly.

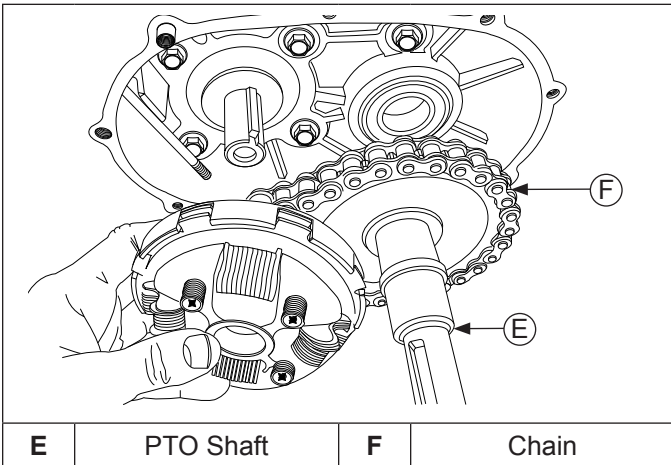

- Separate clutch assembly components. Note order of disassembly.

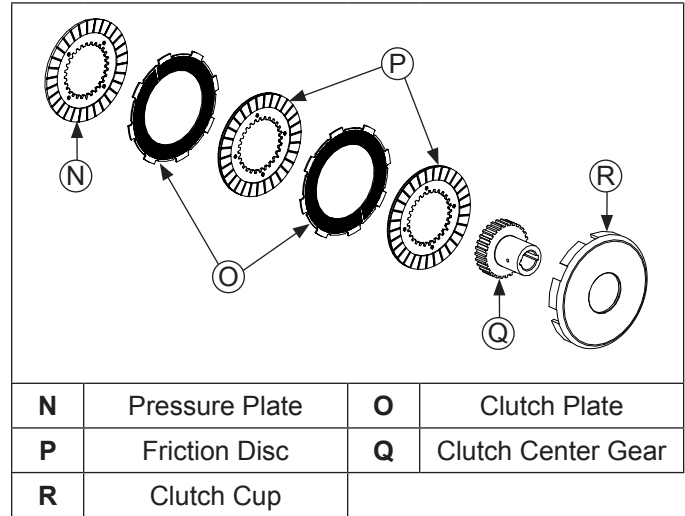

- Disassembly of pressure plate assembly is not recommended. If damage is found, replace as an assembly.
- Remove key and thrust washer from PTO shaft. Note that smaller shoulder faces towards engine.

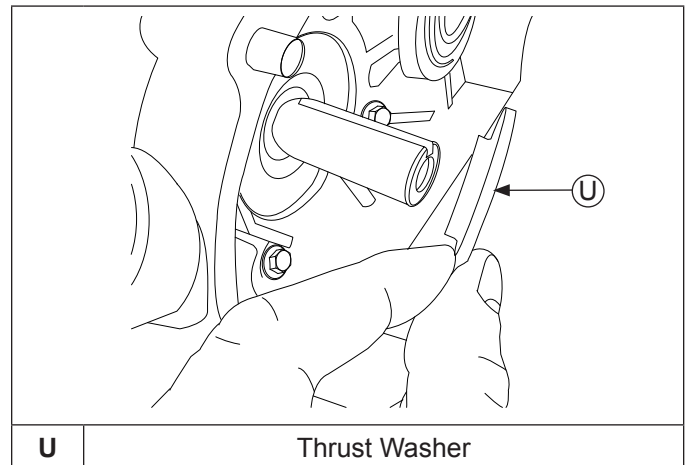

10. If servicing requires reduction case removal, remove screws securing case to closure plate.
11. Carefully separate reduction case and gasket from closure plate.

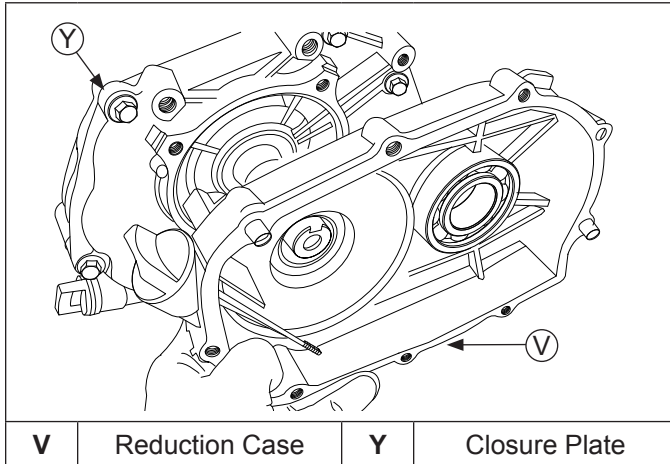

Inspection

NOTE: Disassembly of pressure plate is not recommended and if worn or damaged, should be replaced as an assembly.

Remove gaskets and clean all gasket surfaces. Do not nick or damage surfaces. Inspect each clutch disc and plate as well as pressure plate assembly for abnormal wear, damage, or burning/overheating. Clean and inspect condition of all gears and teeth for wear, chips, or damage. Rotate bearings and check for any roughness. Inspect bearing surfaces for any damage or irregularities. Replace parts as required if damaged or questionable in any way.

Reassembly

NOTE: Use new gaskets when assembling.

NOTE: Lightly lubricate metal clutch plate surfaces, all bearings, and gears with clean oil before assembling.

1. If removed, install reduction case and a new gasket to closure plate. Secure with screws and torque to 24.4 N·m (216 in. lb.).
2. Install key and shoulder washer to PTO shaft. Note that smaller shoulder faces towards engine.
3. Install clutch assembly, chain, and PTO shaft with spring washer in reduction unit.
4. Secure clutch assembly to PTO shaft with screw and lock washer. Torque screw to 24.4 N·m (216 in. lb.).
5. Using new reduction cover gasket, install reduction cover to reduction case. Secure with screws. Torque screws to 7.4 N·m (66 in. lb.).
6. Reinstall reduction unit drain plug and tighten securely.
7. Engine must be level. Add new 20W-40 or 20W-50 oil through oil dipstick hole on top of reduction case until oil level is up to bottom of mark on oil dipstick in reduction case. Reinstall dipstick securely into reduction case.

Gear Reduction System

CH395/CH440 6:1 Gear Reduction System

Components

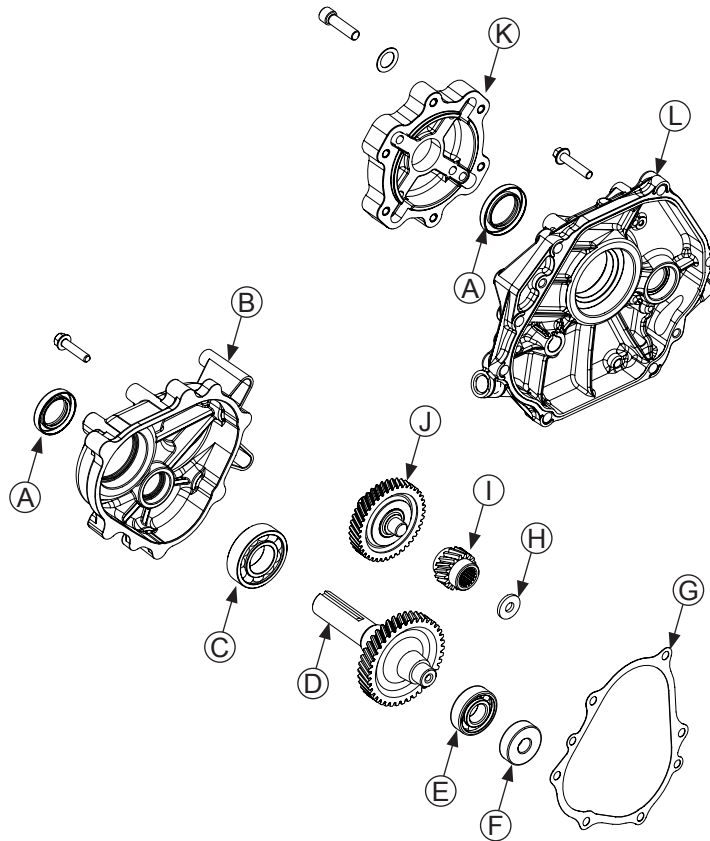

A	Oil Seal	B	Reduction Cover	C	Reduction Cover Bearing	D	PTO Shaft
E	Ball Bearing	F	Spacer	G	Reduction Cover Gasket	H	Flat Washer
I	Drive Gear	J	Countershaft Gear Assembly	K	PTO Flange Adapter	L	Closure Plate

This reduction system is lubricated by engine crankcase oil. No special maintenance or service is necessary. Check and maintain engine oil level as outlined in Check Oil Level (see Lubrication System).

Disassembly

NOTE: Place a drain pan under gear reduction unit to catch any residual oil when cover is removed. Dispose of used oil in accordance with local ordinances.

NOTE: Countershaft and PTO shaft bearings can be removed if necessary using a bearing puller. PTO shaft bearing removal requires closure plate removal. Refer to Disassembly/Inspection and Service for procedure.

1. Remove engine oil drain plug and drain oil into suitable container.
2. Remove any drive coupling and key from reduction assembly PTO shaft. Clean shaft and keyway of any burrs/damage.
3. Remove screws securing reduction cover to closure plate.

4. Remove reduction cover and gasket.

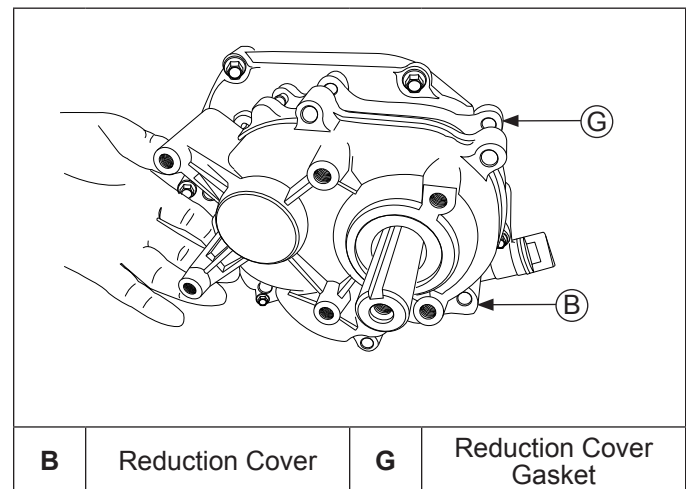

B	Reduction Cover	G	Reduction Cover Gasket
----------	-----------------	----------	------------------------

Gear Reduction System

5. Remove PTO shaft from bearing in closure plate.

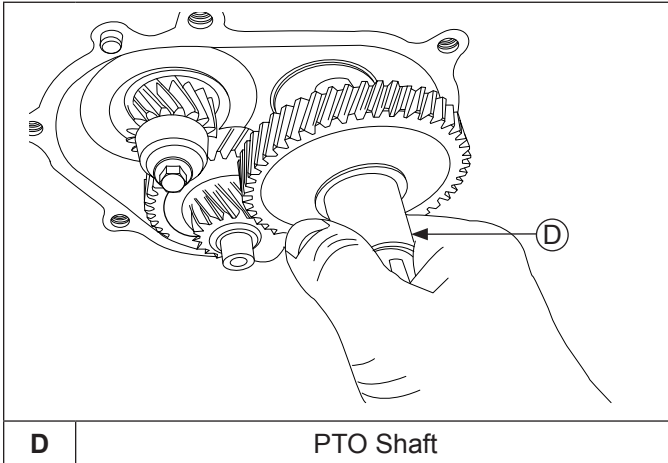

6. Remove screw, flat washer and lock washer securing drive gear to PTO shaft. Slide gear off of PTO shaft splines.

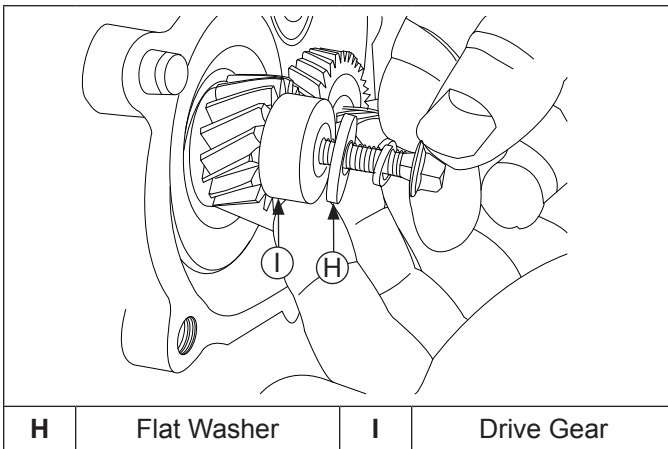

7. Remove countershaft gear assembly from closure plate.

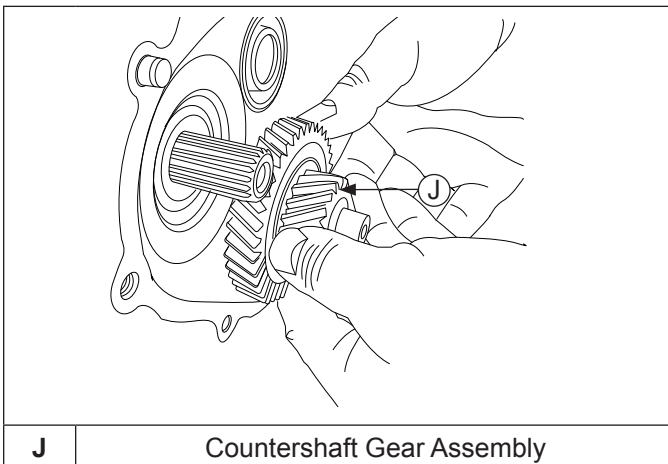

Inspection

Remove all gaskets and clean all gasket surfaces. Do not nick or damage surfaces. Clean and inspect condition of all gears and teeth for any abnormal wear or damage. Replace as necessary. Rotate bearings and check for any roughness. Inspect bearing surfaces for any damage or irregularities. Replace as necessary.

Reassembly

NOTE: Use new gaskets and outer seal when assembling. Lightly lubricate lip of seal with oil.

1. Install countershaft gear assembly in closure plate.
2. Secure drive gear to PTO shaft with screw, flat washer and lock washer. Torque screw to 24.4 N·m (216 in. lb.).
3. Install PTO shaft into bearing in closure plate.
4. Install new reduction cover gasket with reduction cover to closure plate. Secure with screws and torque to 24.4 N·m (216 in. lb.).
5. Install key into keyway of PTO shaft.
6. Refill engine oil as outlined in Change Oil (see Lubrication System).

Gear Reduction System

CH395/CH440 2:1 with Clutch Gear Reduction System

Components

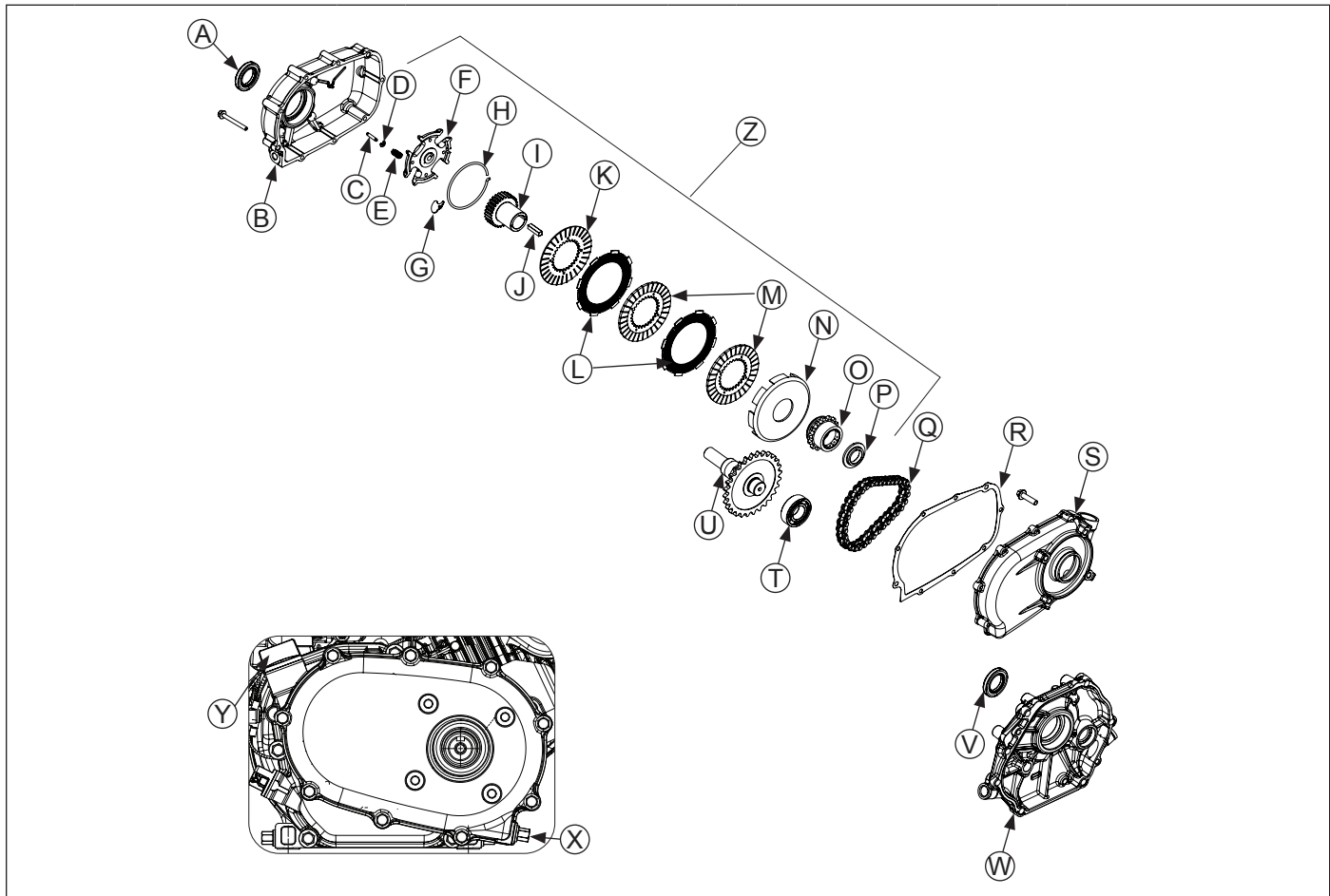

A	Oil Seal	B	Reduction Cover	C	Weight Holder Pin	D	Retaining Ring
E	Clutch Holder Spring	F	Weight Holder	G	Clutch Weight	H	Weight Retainer
I	Clutch Center Gear	J	Square Key	K	Pressure Plate	L	Clutch Plate
M	Friction Disc	N	Clutch Cup	O	Drive Gear	P	Thrust Washer
Q	Chain	R	Reduction Cover Gasket	S	Reduction Case	T	Ball Bearing
U	PTO Shaft	V	Crankshaft Bearing	W	Closure Plate	X	Drain Plug
Y	Reduction Case Dipstick	Z	Clutch Assembly				

NOTE: Engines with this reduction system must be operated at 2400 RPM or higher under load, when full gear box engagement occurs. Operating engine under heavy loads below 2400 RPM, could result in clutch/gear box failure from disc slippage/overheating and insufficient engine cooling, not covered under normal warranty.

This reduction system uses a clutch assembly and chain and sprocket drive system, independent of, and separated from main crankcase lubrication. Check and maintain oil level using dipstick in gear box (reduction) case. Change reduction system oil at interval in maintenance schedule (see Maintenance). Use 20W-40 or 20W-50 oil in this gear box (reduction) case. Oil capacity of this gear box is 0.5 L (0.52 U.S. qt.).

Gear Reduction System

Disassembly

NOTE: Place a drain pan under gear reduction unit to catch any residual oil when cover is removed. Dispose of used oil in accordance with local ordinances.

NOTE: Bearing in cover can be removed if necessary using a bearing puller. Crankshaft bearing removal requires closure plate removal. Refer to Disassembly/Inspection and Service for procedure.

1. Remove any drive coupling and key from reduction assembly PTO shaft. Clean shaft and keyway of any burrs/damage.
2. Remove drain plug and reduction case dipstick, and drain oil into suitable container.
3. Remove screws securing reduction cover to reduction case.

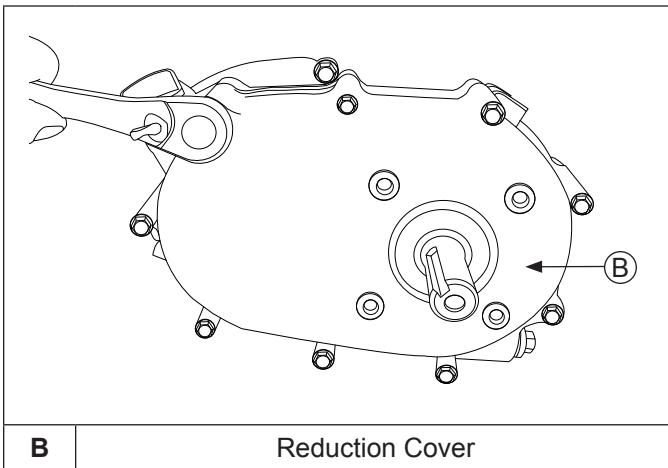

4. Remove reduction cover and gasket. Ensure two dowel pins remain in place.
5. Remove screw and lock washer securing clutch assembly to crankshaft.

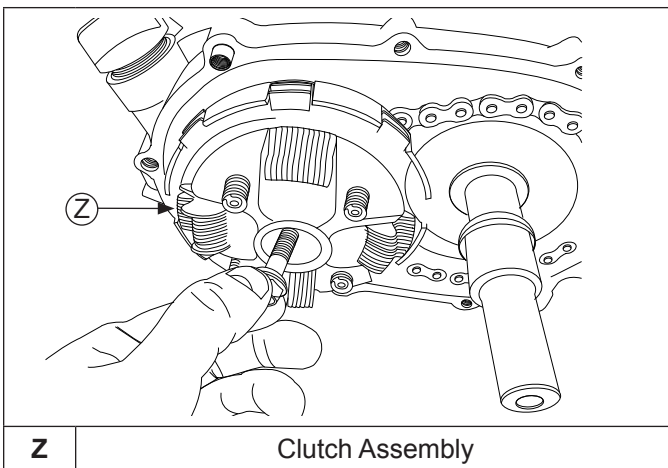

6. Carefully remove clutch assembly, chain, and PTO shaft with spring washer from unit as an assembly.

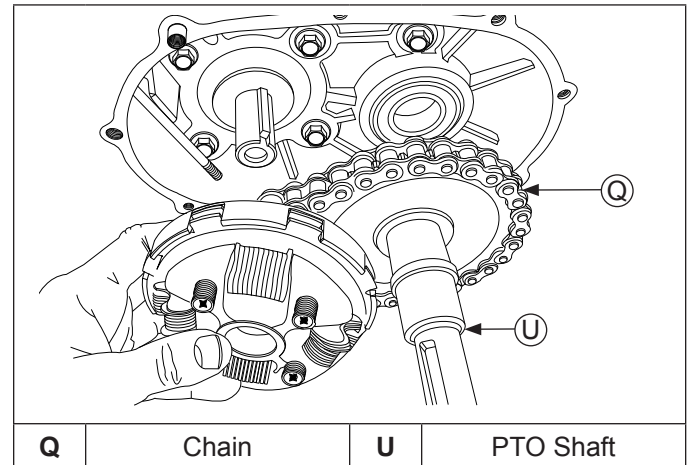

7. Separate clutch assembly components. Note order of disassembly.

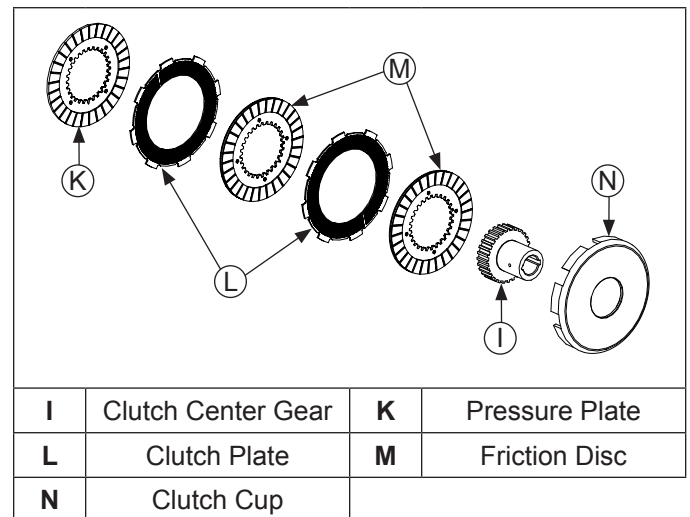

8. Remove key and thrust washer from PTO shaft. Note that smaller shoulder faces towards engine.

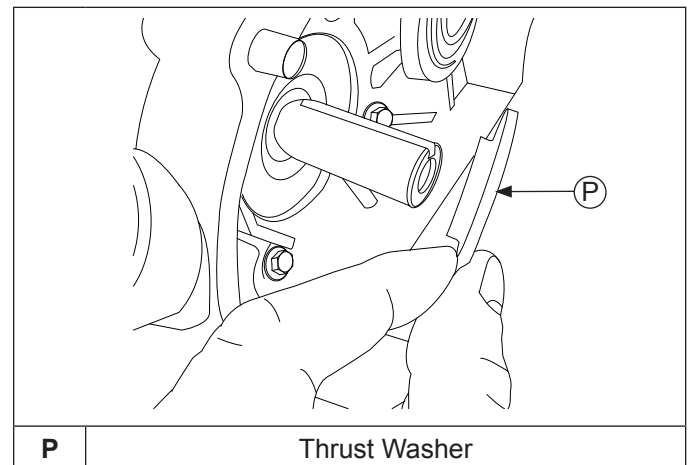

Gear Reduction System

9. If servicing requires reduction case removal, remove screws securing case to closure plate.
10. Carefully separate reduction case and gasket from closure plate.

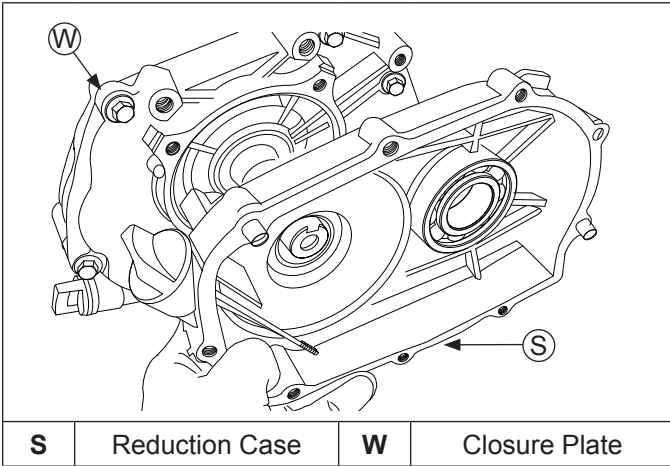

Inspection

NOTE: Disassembly of pressure plate is not recommended and if worn or damaged, should be replaced as an assembly.

Remove gaskets and clean all gasket surfaces. Do not nick or damage surfaces. Inspect each clutch disc and plate as well as pressure plate assembly for abnormal wear, damage, or burning/overheating. Clean and inspect condition of all gears and teeth for wear, chips, or damage. Rotate bearings and check for any roughness. Inspect bearing surfaces for any damage or irregularities. Replace parts as required if damaged or questionable in any way.

Reassembly

NOTE: Use new gaskets when assembling.

NOTE: Lightly lubricate metal clutch plate surfaces, all bearings, and gears with clean oil before assembling.

1. If removed, install reduction case and a new gasket to closure plate. Secure with screws and torque to 24.4 N·m (216 in. lb.).
2. Install key and shoulder washer to PTO shaft. Note that smaller shoulder faces towards engine.
3. Install clutch assembly, chain, and PTO shaft with spring washer in reduction unit.
4. Secure clutch assembly to PTO shaft with screw and lock washer. Torque screw to 24.4 N·m (216 in. lb.).
5. Using new reduction cover gasket, install reduction cover to reduction case. Secure with screws. Torque screws to 7.4 N·m (66 in. lb.).
6. Reinstall reduction unit drain plug and tighten securely.
7. Engine must be level. Add new 20W-40 or 20W-50 oil through oil dipstick hole on top of reduction case until oil level is up to bottom of mark on oil dipstick in reduction case. Reinstall dipstick securely into reduction case.

Disassembly/Inspection and Service

	⚠ WARNING	Before working on engine or equipment, disable engine as follows: 1) Disconnect spark plug lead(s). 2) Disconnect negative (-) battery cable from battery.
	Accidental Starts can cause severe injury or death. Disconnect and ground spark plug lead(s) before servicing.	

External Engine Components

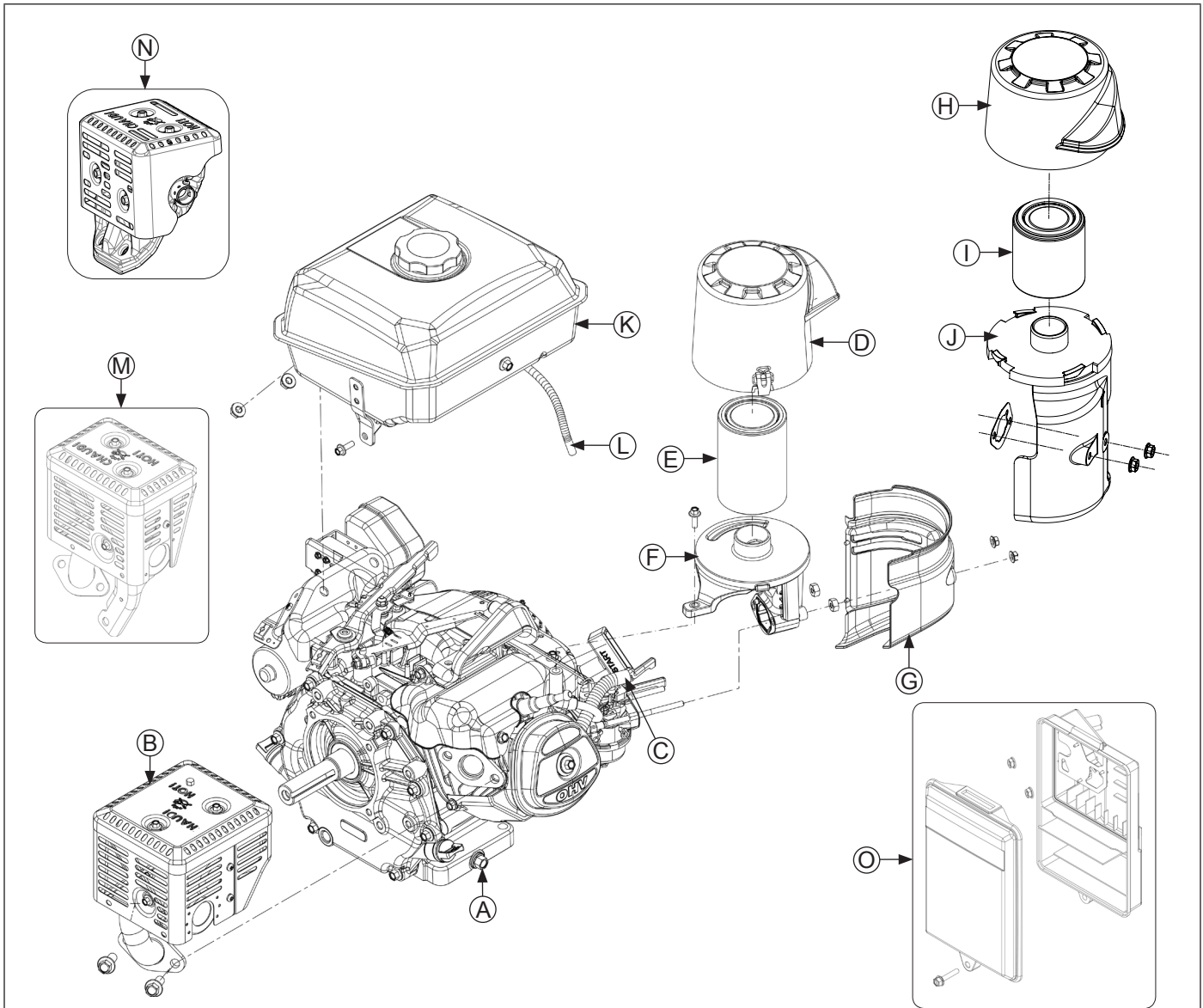

A	Oil Drain Plug	B	CH395, CH440 Muffler Assembly	C	Breather Hose	D	CH260-CH440 Quad-Clean™ Cover
E	CH260-CH440 Quad-Clean™ Element/Precleaner	F	CH260-CH440 Quad-Clean™ Base	G	CH260-CH440 Carburetor Shroud	H	CH245-CH255 Quad-Clean™ Cover
I	CH245-CH255 Quad-Clean™ Element/Precleaner	J	CH245-CH255 Quad-Clean™ Base	K	Fuel Tank	L	Fuel Line
M	CH260, CH270 Muffler Assembly	N	CH245, CH255 Muffler Assembly	O	Low-Profile Air Cleaner		

Disassembly/Inspection and Service

Clean all parts thoroughly as engine is disassembled. Only clean parts can be accurately inspected and gauged for wear or damage. There are many commercially available cleaners that will quickly remove grease, oil, and grime from engine parts. When such a cleaner is used, follow manufacturer's instructions and safety precautions carefully.

Make sure all traces of cleaner are removed before engine is reassembled and placed into operation. Even small amounts of these cleaners can quickly break down lubricating properties of engine oil.

Disconnect Spark Plug Lead

Fuel Valve Details

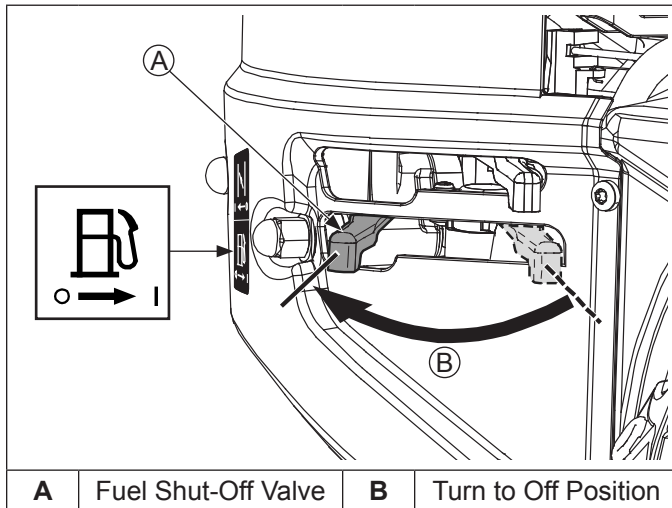

NOTE: Pull on boot only, to prevent damage to spark plug lead.

NOTE: Models with low-profile air cleaner do not have fuel shut-off valve. Instead, turn off fuel at fuel supply.

1. Disconnect lead from spark plug.
2. Push fuel shut-off lever left to close fuel valve.

Drain Oil From Crankcase

1. Remove 1 oil drain plug and 1 oil fill plug.
2. Allow ample time for oil to drain from crankcase.

Remove Pipe Protector Shield (if equipped)

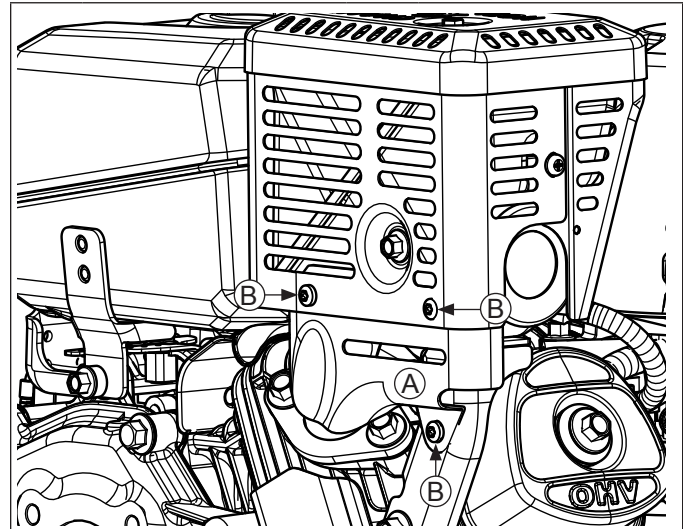

A	Pipe Protector Shield	B	Screw
----------	-----------------------	----------	-------

Remove screws securing pipe protector shield to muffler; remove pipe protector shield.

Remove Exhaust Deflector (if equipped)

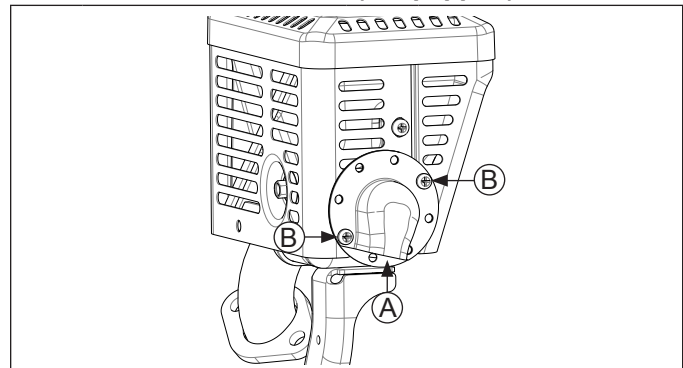

A	Exhaust Deflector	B	Screw
----------	-------------------	----------	-------

NOTE: Unless exhaust deflector is damaged, disassembly from muffler is unnecessary.

NOTE: Make note of position of exhaust deflector before removing.

Remove screws securing exhaust deflector to muffler; remove exhaust deflector.

Remove Muffler and Heat Shield Assembly

1. Remove screws from exhaust flange and muffler bracket.
2. Remove muffler assembly from exhaust outlet.
3. Remove exhaust gasket from outlet.

Remove Air Cleaner Assembly

Remove air cleaner components from air cleaner base. Refer to Air Cleaner/Intake.

Remove Quad-Clean™ Base

Remove air cleaner base from engine as follows:

CH245/CH255

1. Remove nuts and screws securing air cleaner base to engine.
2. Slide base forward on studs.
3. Disconnect breather hose from valve cover.
4. Pull air cleaner base off studs.
5. Remove air cleaner base gasket from mounting studs.
6. Loosely install nuts on studs (to temporarily hold carburetor on engine).

CH260-CH440

1. Remove nuts and screws securing carburetor shroud to engine.
2. Remove shroud.
3. Remove screw and nuts securing air cleaner base to carburetor.
4. Disconnect one end of breather hose from valve cover or air cleaner base.
5. Pull air cleaner base off studs.
6. Remove air cleaner base gasket from mounting studs.
7. Loosely install nuts on studs (to temporarily hold carburetor on engine).

Remove Low-Profile Air Cleaner Base

Remove air cleaner base from engine as follows:

1. Remove screw and nuts securing air cleaner base to carburetor.
2. Disconnect one end of breather hose from valve cover or air cleaner base.
3. Remove base.
4. Remove air cleaner base gasket from mounting studs.
5. Loosely install nuts on studs (to temporarily hold carburetor on engine).

Remove Fuel Tank (if equipped)

NOTE: If no fuel tank is equipped, loosen clamp and disconnect fuel line from inlet of carburetor.

NOTE: On CH245/CH255 engines, remove screws securing speed control assembly to crankcase, for access to screw securing fuel tank.

1. Ensure fuel tank is empty.
2. Loosen clamp and disconnect fuel line from inlet of shut-off valve.
3. Remove screws and nuts securing fuel tank to engine brackets and remove tank from engine.

Disassembly/Inspection and Service

CH245/CH255 Blower Housing/Control Panel Components

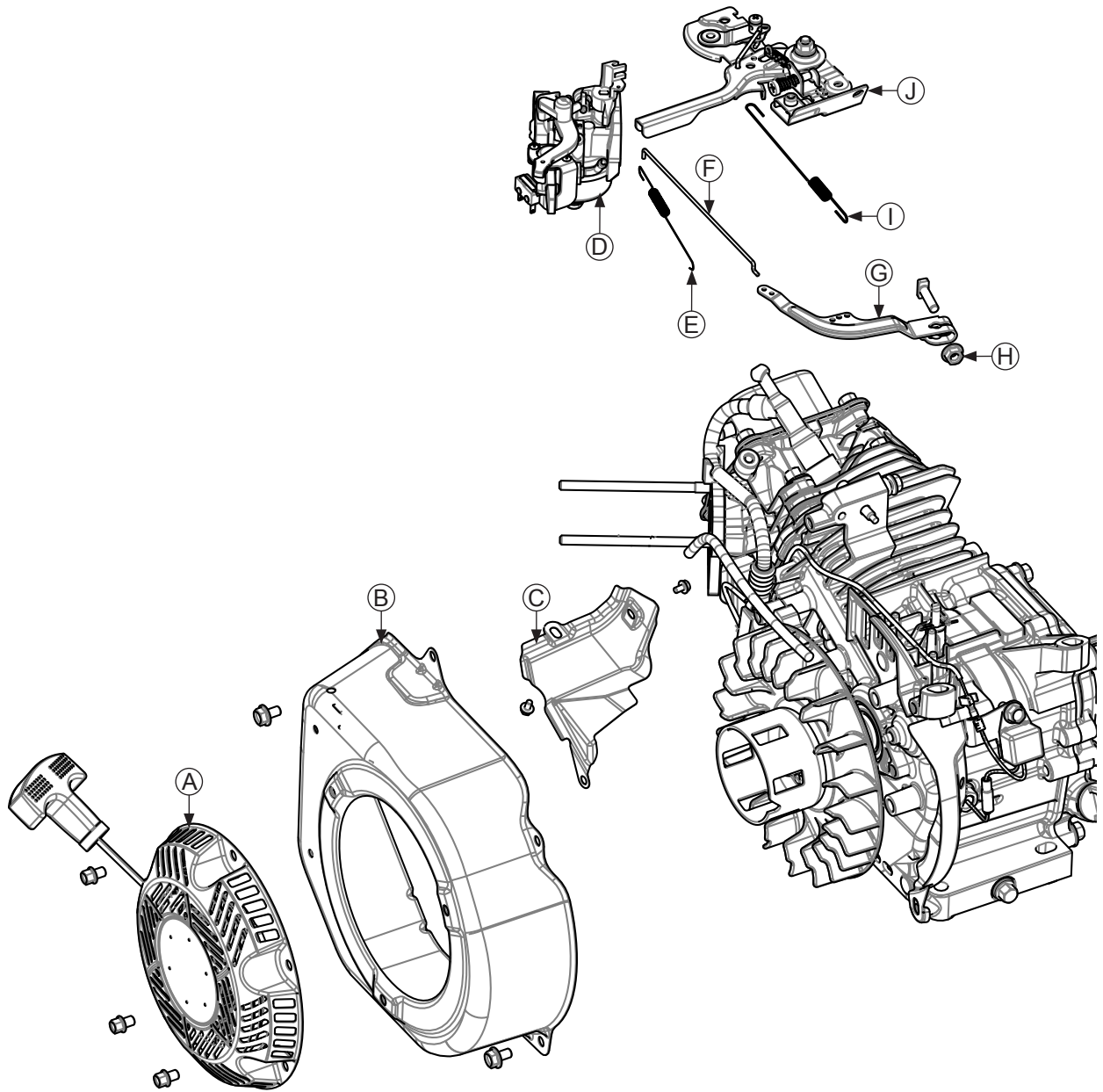

A	Retractable Starter	B	Blower Housing	C	Cylinder Head Shield	D	Carburetor
E	Linkage Spring	F	Throttle Linkage	G	Governor Lever	H	Hex Flange Nut
I	Governor Spring	J	Speed Control Assembly				

CH260/CH270 Blower Housing/Control Panel Components

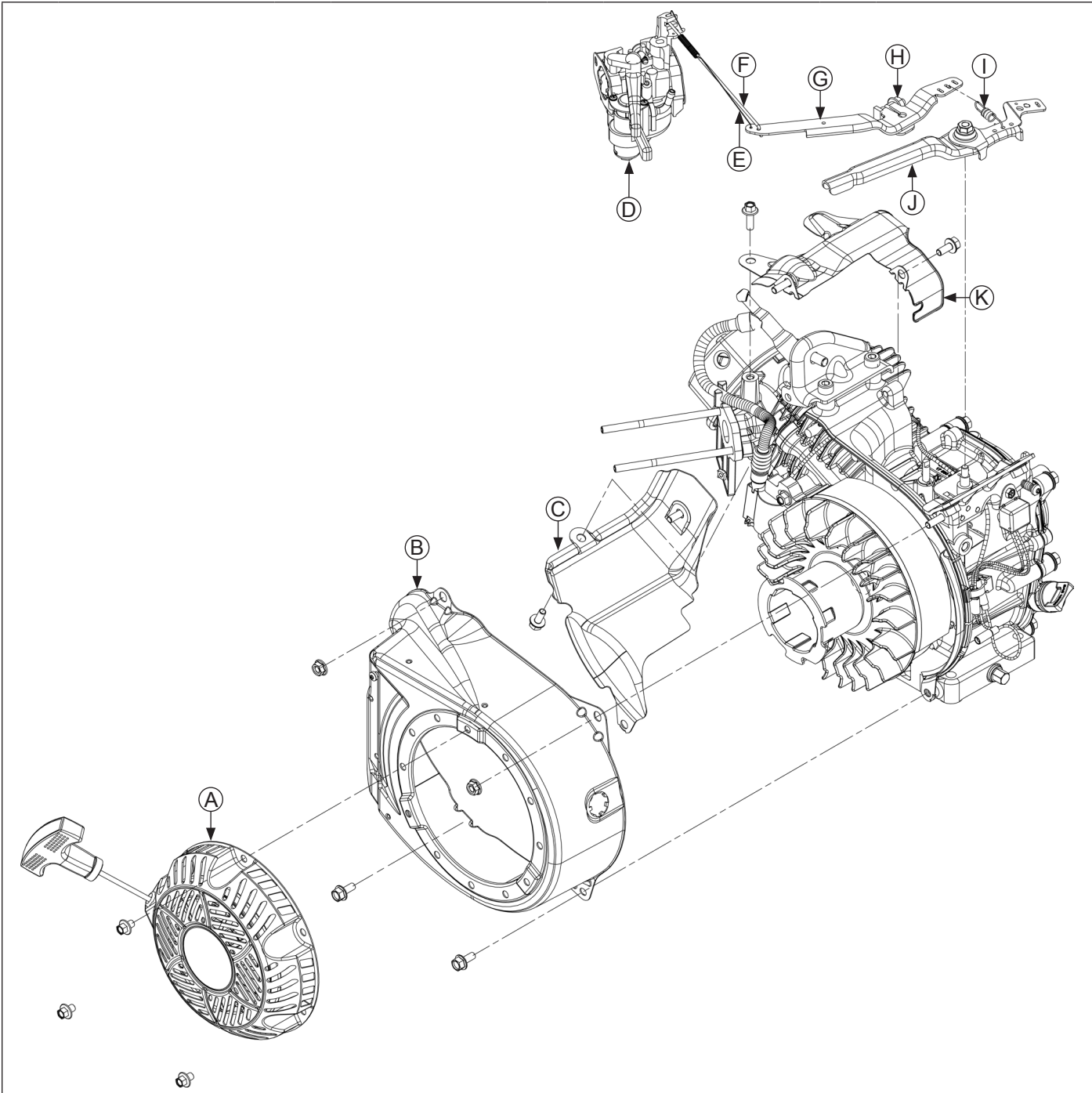

A	Retractable Starter	B	Blower Housing	C	Lower Shield	D	Carburetor
E	Dampening Spring	F	Throttle Linkage	G	Governor Lever	H	Hex Flange Nut
I	Governor Spring	J	Throttle Lever	K	Upper Shield		

Disassembly/Inspection and Service

CH395/CH440 Blower Housing/Control Panel Components

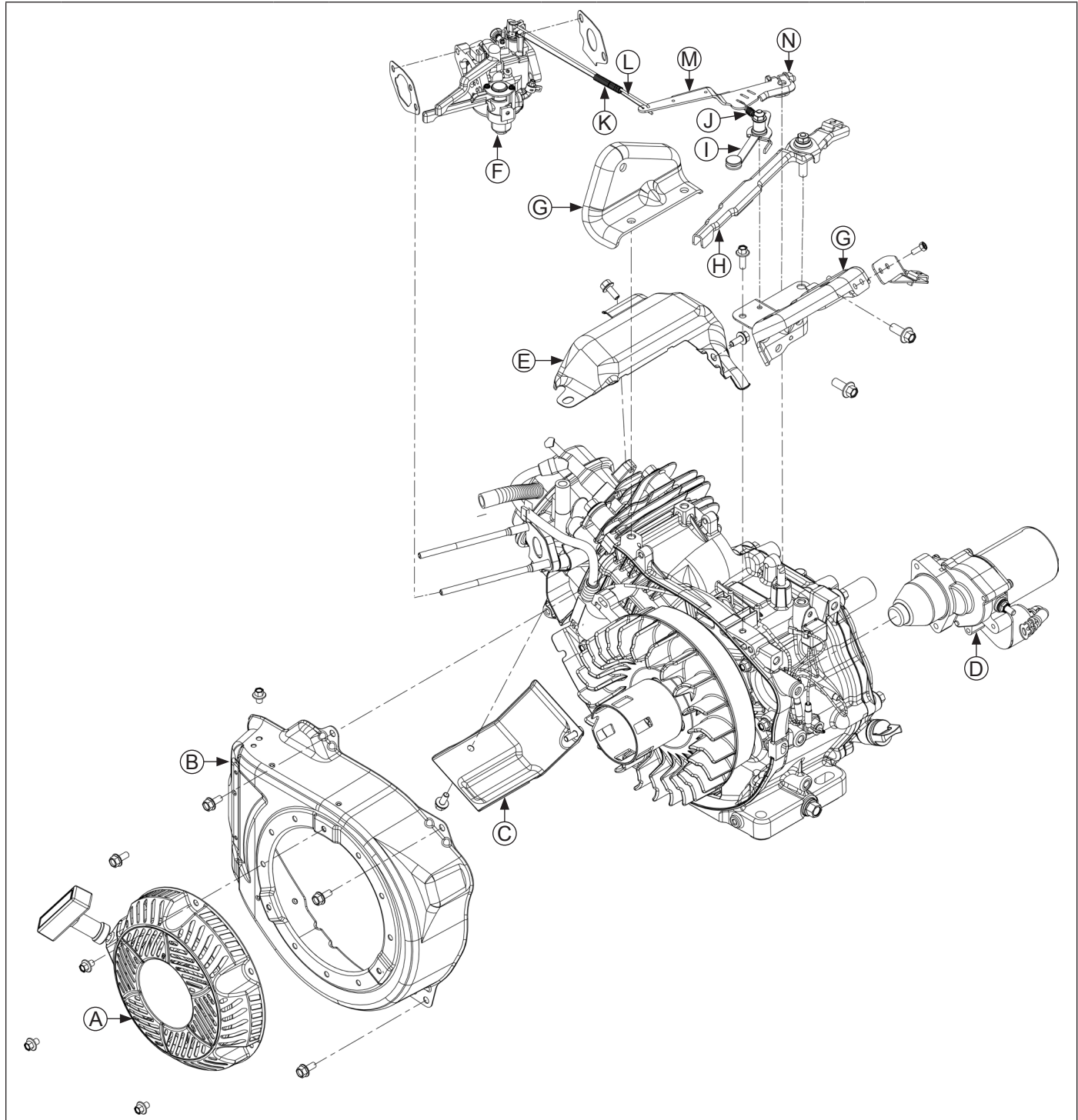

A	Retractable Starter	B	Blower Housing	C	Lower Shield	D	Electric Starter
E	Upper Shield	F	Carburetor	G	Fuel Brackets	H	Throttle Lever
I	Pivot Lever	J	Governor Spring	K	Dampening Spring	L	Throttle Linkage
M	Governor Lever	N	Hex Flange Nut				

CH395/CH440 Electronic Governor Blower Housing/Control Panel Components

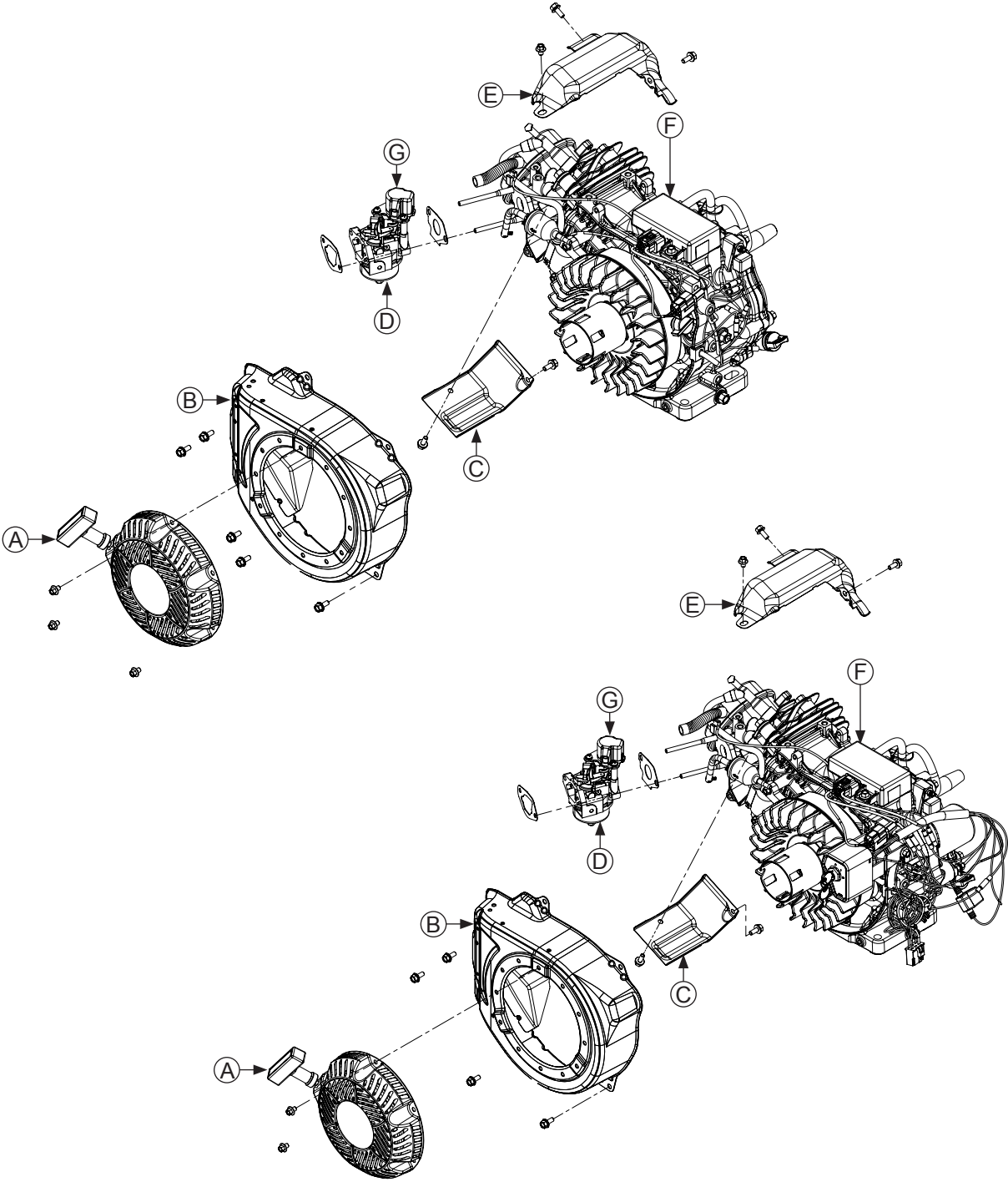

A	Retractable Starter	B	Blower Housing	C	Lower Shield	D	Carburetor
E	Upper Shield	F	Electric Governor Control	G	Stepper Motor		

Disassembly/Inspection and Service

Remove External Throttle, Governor and Choke Linkage (Mechanical Governor Only)

1. Mark which hole location governor spring is in on each side. Remove nut and washer securing throttle control lever to crankcase. Unhook spring and remove lever.
2. Loosen nut securing governor lever to governor shaft. Lift off governor lever and remove carburetor throttle link and dampening spring.

Remove Carburetor

	WARNING
	Explosive Fuel can cause fires and severe burns. Do not fill fuel tank while engine is hot or running.
Gasoline is extremely flammable and its vapors can explode if ignited. Store gasoline only in approved containers, in well ventilated, unoccupied buildings, away from sparks or flames. Spilled fuel could ignite if it comes in contact with hot parts or sparks from ignition. Never use gasoline as a cleaning agent.	

NOTE: To remove carburetor without disturbing governor lever mounting, pull carburetor outward and off mounting studs. Tilt carburetor and disconnect throttle link and dampening spring from throttle lever.

1. Disconnect throttle link and dampening spring from carburetor.
2. If equipped with ignition and fuel shut-off, carefully disconnect both wiring harness terminals from micro switch on carburetor.
3. If equipped with a fuel shut-off solenoid, carefully cut plastic tie strap and disconnect both lead wire terminals from solenoid leads.
3. Remove carburetor, carburetor gasket, insulator, and insulator gasket from studs.

Remove Carburetor with Stepper Motor (Electronic Governor Only)

NOTE: Carburetor and stepper motor should be removed as an assembly.

Separate carburetor and stepper motor only if additional service is required. Refer to Governor System.

Disconnect wiring harness from stepper motor. Remove carburetor with stepper motor, carburetor gasket, insulator, and insulator gasket from studs.

Remove Retractable Starter

Remove screws securing retractable starter to blower housing. Remove starter.

Remove Blower Housing and Shields

1. Remove screws and nuts (CH260 and CH270 only) securing blower housing.
2. Remove blower housing.
3. Remove screws securing upper shield and remove shield.
4. Remove screws securing lower shield and remove shield.

Remove Electrical Wiring, Micro Shut Down Switch and Bracket and Fuel Tank Brackets (if equipped)

NOTE: For CH395 and CH440 it is not required and not recommended to remove threaded stud and micro switch bracket.

1. Disconnect wiring harness bullet connectors for Oil Sentry™ float switch and module. Remove mounting screw securing module to fuel tank bracket or module bracket.
2. If equipped, remove both fuel tank brackets by removing screws in each. Remove threaded stud from left bracket and remove micro switch bracket.

Remove Electronic Governor Control (Electronic Governor Only)

1. Mark wire locations and remove wires from control panel.
2. Remove wire harness from electronic governor control.
3. Remove screws securing electronic governor control to crankcase.

Remove Control Panel and Electric Starter (if equipped)

NOTE: To ease reassembly, label wires for proper reconnection as wiring colors may not match.

1. Disconnect wires from control panel to starter, Oil Sentry™, ignition module, and rectifier-regulator.
2. Remove screws securing control panel bracket to crankcase, and remove control panel. Note 2 ground wires secured by one screw.
3. Remove screws securing electric starter to crankcase, and remove electric starter.

CH245/CH255 Cylinder Head Components

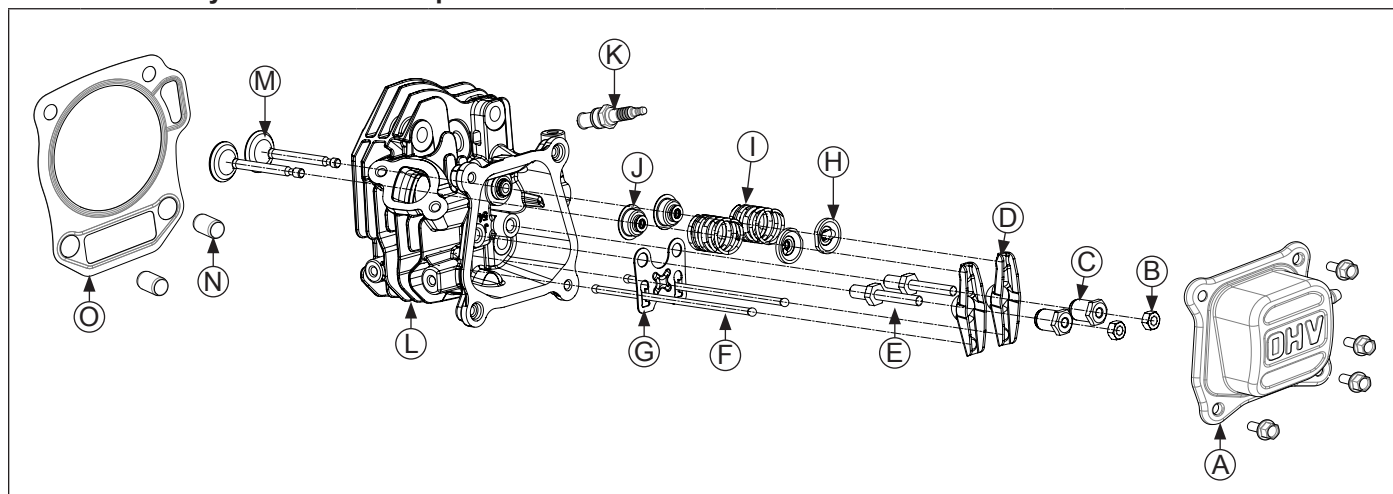

A	Valve Cover	B	Hex Jam Nut	C	Rocker Arm Pivot	D	Rocker Arm
E	Rocker Arm Stud	F	Push Rod	G	Push Rod Guide	H	Valve Keeper
I	Valve Spring	J	Valve Stem Seal	K	Spark Plug	L	Cylinder Head
M	Valve	N	Dowel Pin	O	Cylinder Head Gasket		

CH260-CH440 Cylinder Head Components

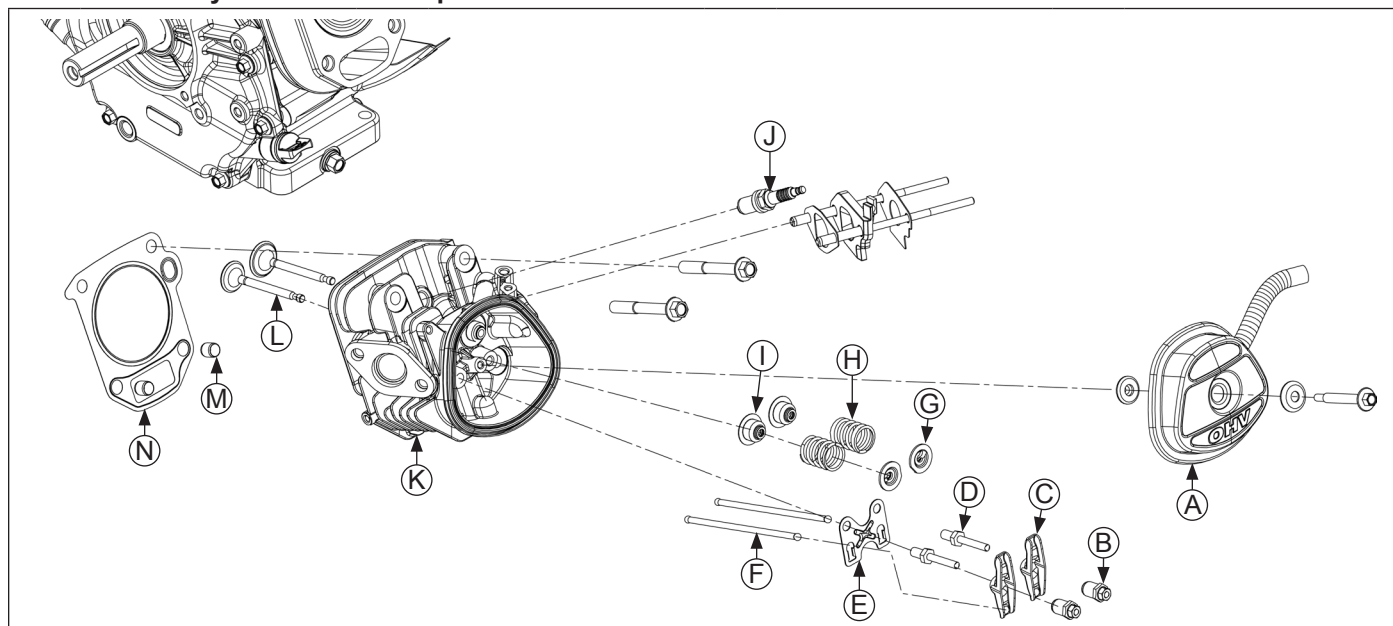

A	Valve Cover	B	Adjuster Nut	C	Rocker Arm	D	Rocker Arm Stud
E	Push Rod Guide	F	Push Rod	G	Valve Keeper	H	Valve Spring
I	Valve Stem Seal	J	Spark Plug	K	Cylinder Head	L	Valve
M	Dowel Pin	N	Cylinder Head Gasket				

Disassembly/Inspection and Service

Remove Valve Cover/Breather, Rocker Arms, Push Rods, and Cylinder Head Assembly

NOTE: Mark location of push rods and any other part removed being reused.

NOTE: CH245/CH255 valve cover is sealed to cylinder head using RTV silicone sealant. When removing valve cover, use care not to damage sealing surfaces of cover and cylinder head. To break RTV seal, hold a block of wood against 1 flat face of valve cover. Strike wood firmly with a mallet. If seal doesn't break loose after 1 or 2 attempts, repeat procedure on other side.

1. CH245/CH255: Remove screws and remove valve cover from engine. Breather assembly is inside valve cover. Using a brass wire brush and gasket remover or similar solvent, clean old RTV from surface of cylinder head and valve cover.

CH260-CH440: Remove screw and washer, then remove valve cover and gasket from engine. Breather assembly is inside valve cover.

2. Loosen and remove rocker arm lock and adjuster nuts. Remove rocker arms and push rods.
3. Remove spark plug.
4. Remove screws securing cylinder head.
5. Remove cylinder head, dowel pins (note location for reassembly), and cylinder head gasket.

Breather System

Breather system is designed to control amount of oil in head area and still maintain necessary vacuum in crankcase.

When pistons move downward, crankcase gases are pushed past reed through mesh filter into intake system. Upward travel of pistons closes reed and creates a low vacuum in lower crankcase. Any oil separated out through filter drains back into crankcase.

Remove Valves

NOTE: Mark locations of any part removed being reused.

1. Supporting head of valve from below, depress valve keeper and valve spring until keeper can be released from valve stem. Remove valve spring and valve from head. Repeat this procedure for remaining valve.
2. Remove and replace valve stem seals whenever cylinder head is serviced or disassembled.

Inspection and Service

After cleaning, check flatness of cylinder head and corresponding top surface of crankcase, using a surface plate or precision straight edge and feeler gauge. Maximum allowable out of flatness is:

0.1 mm (0.0039 in.) for CH245, CH255, CH395, CH440.

0.08 mm (0.003 in.) for CH260, CH270.

Carefully inspect valve mechanism parts. Inspect valve springs and related hardware for excessive wear or distortion. Check valves and valve seat area or inserts for evidence of deep pitting, cracks, or distortion. Check clearance of valve stems in guides.

Hard starting, or loss of power accompanied by high fuel consumption may be symptoms of faulty valves. Although these symptoms could also be attributed to worn rings, remove and check valves first. After removal, clean valve heads, faces, and stems with a power wire brush.

Then, carefully inspect each valve for defects such as warped head, excessive corrosion, or worn stem end. Replace valves found to be in bad condition.

Valve Guides

If a valve guide is worn beyond specifications, it will not guide valve in a straight line. This may result in burnt valve faces or seats, loss of compression, and excessive oil consumption.

To check valve guide-to-valve stem clearance, thoroughly clean valve guide and, using a split-ball gauge, measure inside diameter of guide. Then, using an outside micrometer, measure diameter of valve stem at several points on stem where it moves in valve guide. Use largest stem diameter to calculate clearance by subtracting stem diameter from guide diameter. If intake or exhaust clearance exceeds specifications in Valve Specification table, determine whether valve stem or guide is responsible for excessive clearance.

If guides are within limits but valve stems are worn beyond limits, install new valves.

Disassembly/Inspection and Service

Valve Seat Inserts

Hardened steel alloy intake and exhaust valve seat inserts are press-fitted into cylinder head. Inserts are not replaceable but can be reconditioned if not too badly pitted or distorted. If cracked or badly warped, cylinder head should be replaced.

Recondition valve seat inserts following instructions provided with valve seat cutter being used. Cutting proper valve face angle, as specified in Valve Specification table and proper valve seat angle (89.5°-90°) will achieve desired 0° (1° full cut) interference angle where maximum pressure occurs on outside diameters of valve face and seat.

Lapping Valves

NOTE: Exhaust valves that are black in color cannot be ground and do not require lapping.

Reground or new valves must be lapped in, to provide proper fit. Use a hand valve grinder with suction cup for final lapping. Lightly coat valve face with fine grade of grinding compound, then rotate valve on seat with grinder. Continue grinding until smooth surface is obtained on seat and on valve face. Thoroughly clean cylinder head in soap and hot water to remove all traces of grinding compound. After drying cylinder head, apply a light coating of SAE 10 oil to prevent rusting.

Valve Stem Seals

These engines use valve stem seals on intake and exhaust valves.

Always use new seals when valves are removed from cylinder head. Seals should also be replaced if deteriorated or damaged in any way. Never reuse old seals.

Valve Details

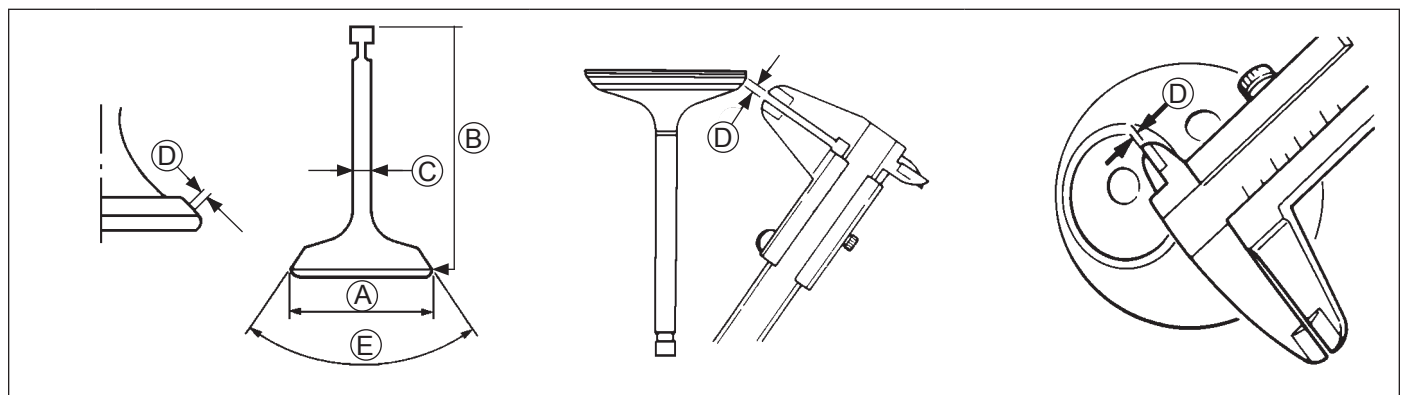

CH245/CH255 Valve Specifications

Item	Dimension	Intake	Exhaust
A	Head Diameter	24.875-25.125 mm (0.9793-0.9892 in.)	23.8-24.2 mm (0.9370-0.9527 in.)
B	Valve Length	64 mm (2.5196 in.)	64 mm (2.5196 in.)
C	Stem Diameter	5.474 mm (0.2155 in.)	5.464 mm (0.2151 in.)
D	Face/Seat Width - Maximum	2.0 mm (0.079 in.)	2.0 mm (0.079 in.)
E	Face/Seat Angle	89.5°-90.5°	89.5°-90.5°

CH260/CH270 Valve Specifications

Item	Dimension	Intake	Exhaust
A	Head Diameter	26.875-27.125 mm (1.0581-1.0679 in.)	24.875-25.125 mm (0.9793-0.9892 in.)
B	Valve Length	63.3-63.9 mm (2.4921-2.5157)	63.3-63.9 mm (2.4921-2.5157)
C	Stem Diameter	5.5 mm (0.217 in.)	5.438 mm (0.214 in.)
D	Face/Seat Width - Maximum	2.0 mm (0.079 in.)	2.0 mm (0.079 in.)
E	Face/Seat Angle	89.5°-90.5°	89.5°-90.5°

Disassembly/Inspection and Service

CH395 Valve Specifications			
Item	Dimension	Intake	Exhaust
A	Head Diameter	30.875-31.125 mm (1.2156-1.2254 in.)	26.875-27.125 mm (1.0581-1.0679 in.)
B	Valve Length	85.34-85.54 mm (3.3598-3.3677 in.)	85.19-84.99 mm (3.3461-3.3539 in.)
C	Stem Diameter	6.560-6.575 mm (0.2583-0.2589 in.)	6.560-6.575 mm (0.2583-0.2589 in.)
D	Face/Seat Width - Maximum	1.5 mm (0.059 in.)	1.5 mm (0.059 in.)
E	Face/Seat Angle	89.5°-90.5°	89.5°-90.5°

CH440 Valve Specifications			
Item	Dimension	Intake	Exhaust
A	Head Diameter	35.875-36.125 mm (1.4124-1.4222 in.)	32.875-33.125 mm (1.2943-1.3041 in.)
B	Valve Length	86.175-86.375 mm (3.3927-3.4006 in.)	86.341-86.541 mm (3.3993-3.4071 in.)
C	Stem Diameter	6.560-6.575 mm (0.2583-0.2589 in.)	6.545-6.560 mm (0.2577-0.2583 in.)
D	Face/Seat Width - Maximum	1.5 mm (0.059 in.)	1.5 mm (0.059 in.)
E	Face/Seat Angle	89.5°-90.5°	89.5°-90.5°

CH245/CH255 Flywheel/Ignition Components

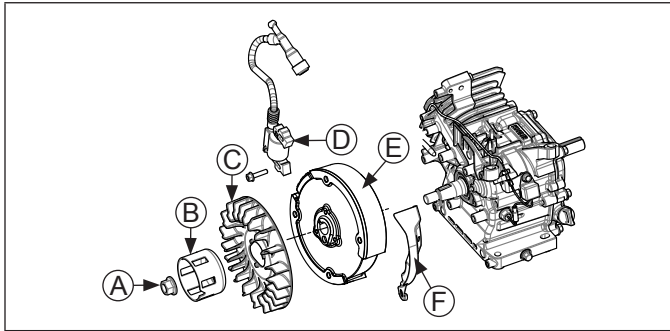

A	Flywheel Retaining Nut	B	Drive Cup
C	Flywheel Fan	D	Ignition Module
E	Flywheel	F	Flywheel Shield

CH260/CH270 Flywheel/Ignition Components

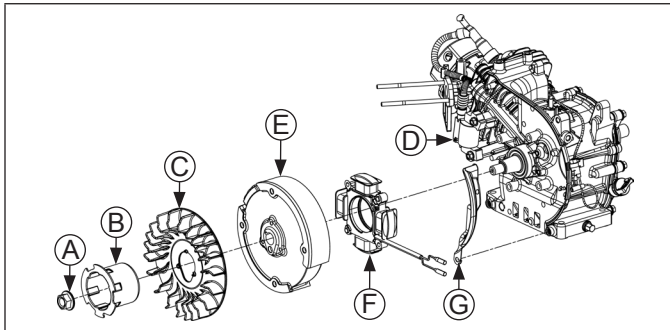

A	Flywheel Retaining Nut	B	Drive Cup
C	Flywheel Fan	D	Ignition Module
E	Flywheel	F	Stator
G	Flywheel Shield		

CH395/CH440 Flywheel/Ignition Components

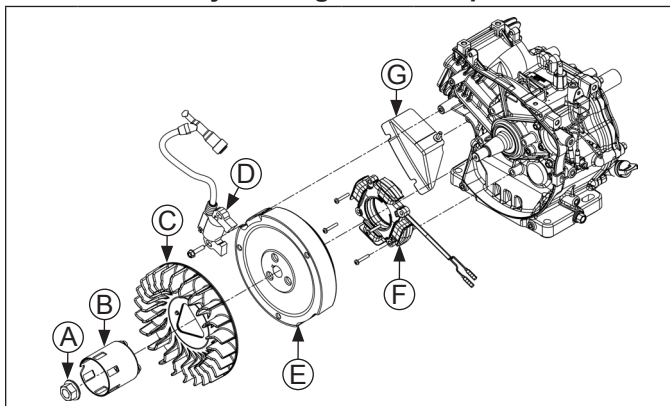

A	Flywheel Retaining Nut	B	Drive Cup
C	Flywheel Fan	D	Ignition Module
E	Flywheel	F	Stator
G	Flywheel Shield		

Remove Ignition Module

NOTE: On engines with a fuel shut-off solenoid, take note of which ignition module screw also secures ground lead ring terminal.

Remove screws securing ignition module to crankcase. Remove module.

Remove Flywheel

NOTE: Whenever possible, an impact wrench should be used to loosen flywheel retaining nut. A flywheel strap wrench may be used to hold flywheel when loosening or tightening flywheel retaining nut.

NOTE: Always use a puller to remove flywheel from crankshaft. Do not strike flywheel or crankshaft as these parts could become cracked or damaged.

1. Remove flywheel retaining nut.
2. Remove drive cup and fan from flywheel.
3. Remove screw and shield (CH245-CH270 only) on right side of flywheel (required for use of puller in next step).
4. Remove flywheel from crankshaft using a suitable puller.
5. Remove flywheel key from crankshaft keyway.

Inspection

Inspect flywheel for cracks and flywheel keyway for damage. Replace flywheel if it is cracked. Replace flywheel, crankshaft, and key if flywheel key is sheared or keyway is damaged.

Remove Stator (if equipped)

1. Remove screw securing stator wire bracket and remove bracket.
2. Remove screws securing stator to crankcase.

Remove Gear Reduction Assembly (if equipped)

Refer to Gear Reduction System for disassembly, inspection, and reassembly procedures.

Disassembly/Inspection and Service

CH245/CH255 Crankshaft/Camshaft/Closure Plate Components

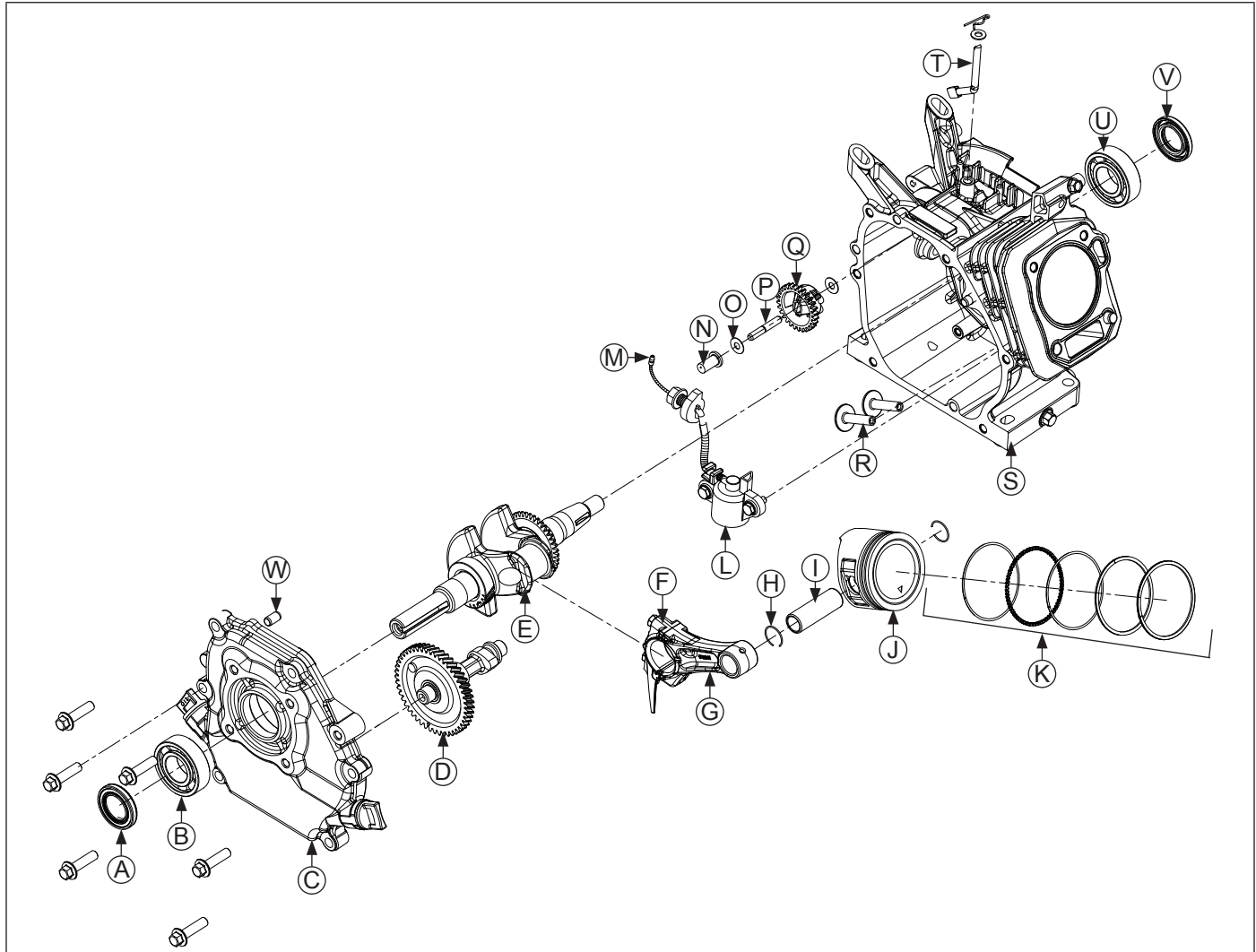

A	Closure Plate Oil Seal	B	Closure Plate Bearing	C	Closure Plate	D	Camshaft
E	Crankshaft	F	Connecting Rod End Cap	G	Connecting Rod	H	Piston Pin Retainer
I	Piston Pin	J	Piston	K	Piston Ring Set	L	Oil Sentry™ Float Switch
M	Oil Sentry™ Wire	N	Governor Cup	O	Governor Washer	P	Governor Shaft
Q	Governor Gear	R	Tappet	S	Crankcase	T	Governor Cross Shaft
U	Crankcase Bearing	V	Crankcase Oil Seal	W	Dowel		

CH260/CH270 Crankshaft/Camshaft/Closure Plate Components

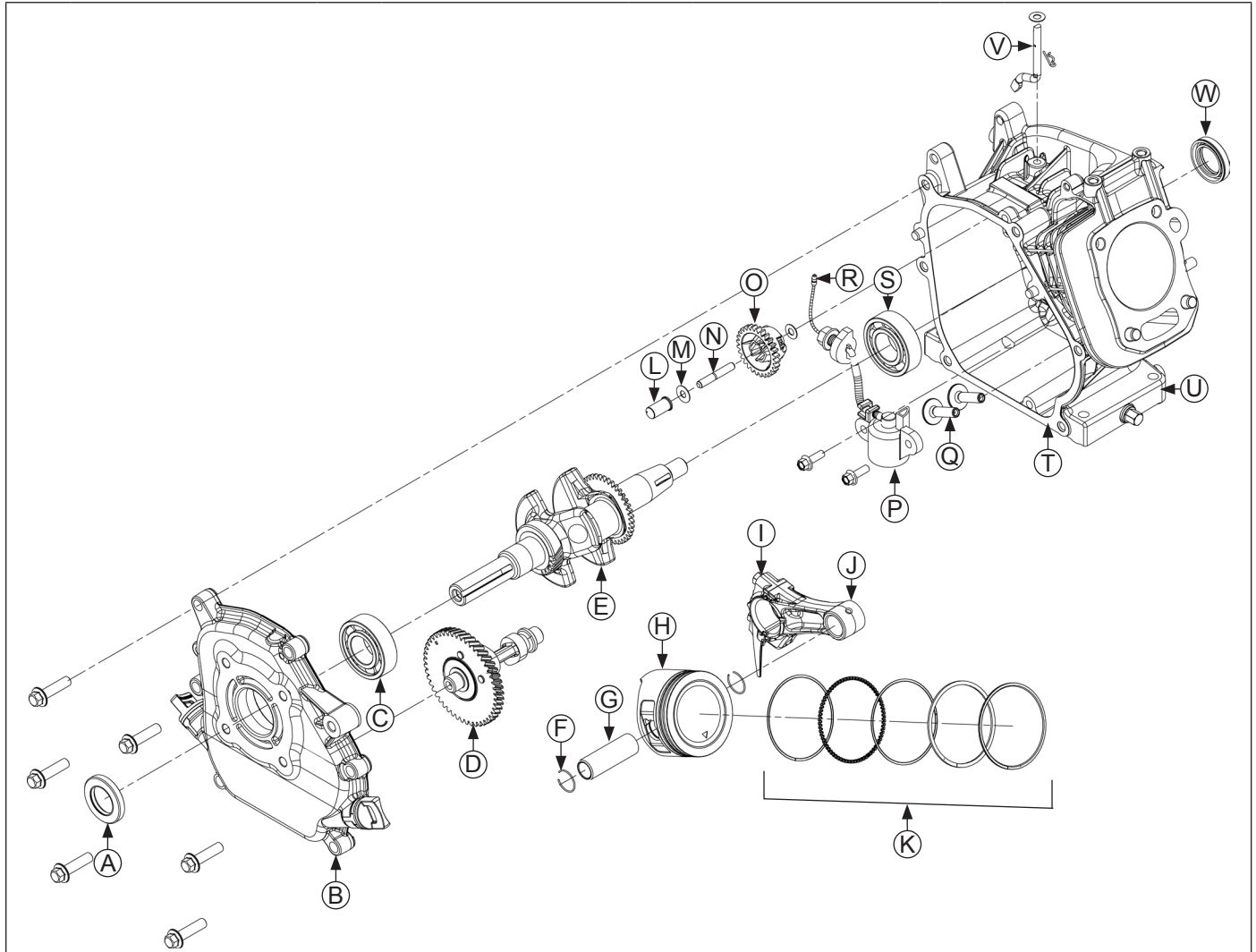

A	Closure Plate Oil Seal	B	Closure Plate	C	Closure Plate Bearing	D	Camshaft
E	Crankshaft	F	Piston Pin Retainer	G	Piston Pin	H	Piston
I	Connecting Rod End Cap	J	Connecting Rod	K	Piston Ring Set	L	Governor Cup
M	Governor Washer	N	Governor Shaft	O	Governor Gear	P	Oil Sentry™ Float Switch
Q	Tappet	R	Oil Sentry™ Wire	S	Crankcase Bearing	T	Closure Plate Gasket
U	Crankcase	V	Governor Cross Shaft	W	Crankcase Oil Seal		

Disassembly/Inspection and Service

CH395/CH440 Crankshaft/Camshaft/Closure Plate Components

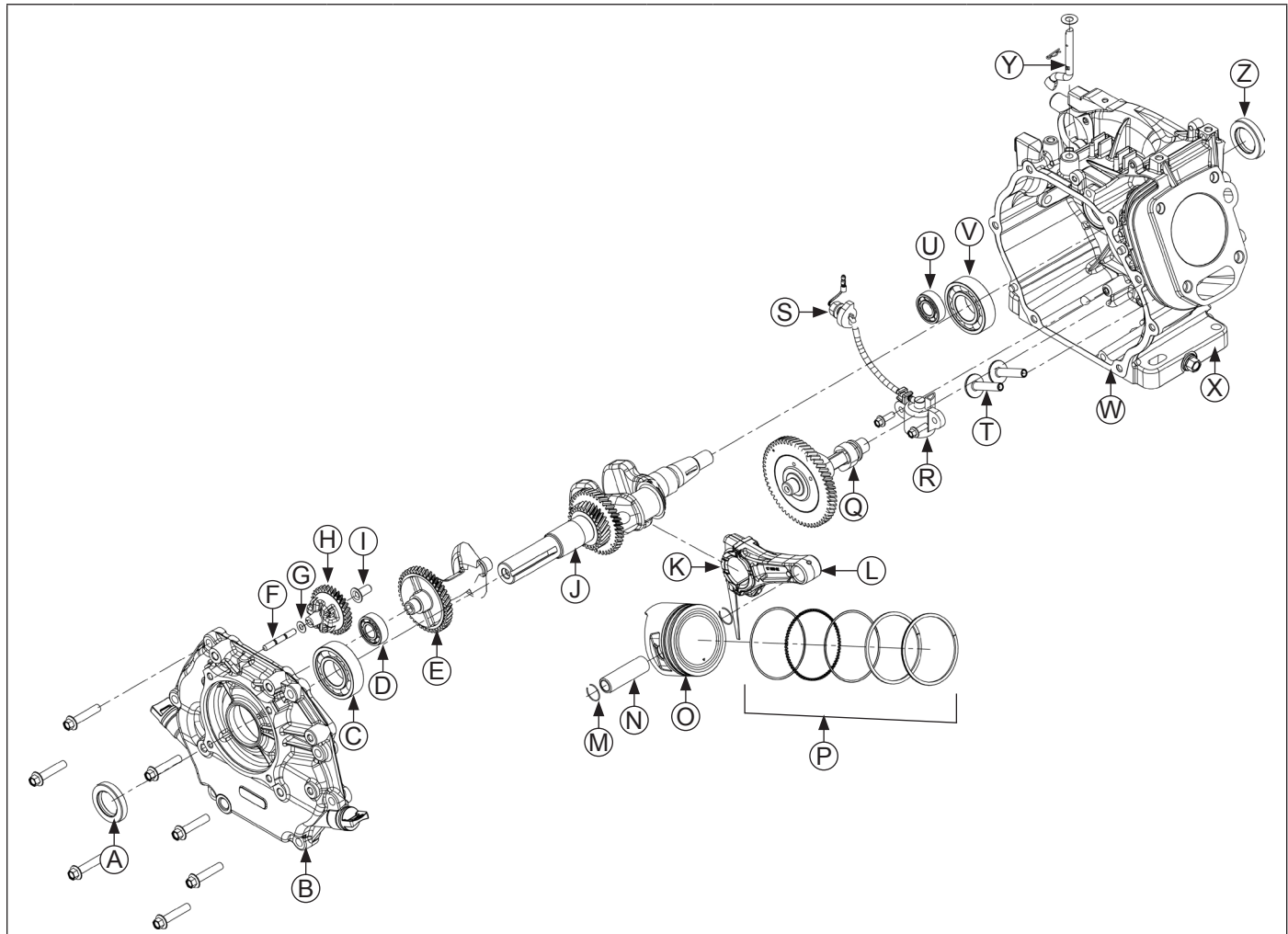

A	Closure Plate Oil Seal	B	Closure Plate	C	Closure Plate Bearing	D	Closure Plate Balance Shaft Bearing
E	Balance Shaft	F	Governor Shaft	G	Governor Washer	H	Governor Gear
I	Governor Cup	J	Crankshaft	K	Connector Rod End Cap	L	Connector Rod
M	Piston Pin Retainer	N	Piston Pin	O	Piston	P	Piston Ring Set
Q	Camshaft	R	Oil Sentry™ Float Switch	S	Oil Sentry™ Wire	T	Tappet
U	Crankcase Balance Shaft Bearing	V	Crankcase Bearing	W	Closure Plate Gasket	X	Crankcase
Y	Governor Cross Shaft	Z	Crankcase Oil Seal				

Remove Closure Plate

NOTE: Do not pry on gasket surface of crankcase or closure plate, as this can cause damage and leakage.

NOTE: Some engines have a closure plate gasket; some engines use RTV to secure closure plate to crankcase.

1. Remove screws securing closure plate to crankcase.
2. Remove closure plate, gasket (if equipped), and dowel pins (if required) from crankcase. Note position of dowel pins for reassembly. Discard old gasket (if equipped).
3. Remove shims from crankshaft and camshaft.

Inspection

Inspect main bearing surface for wear or damage (refer to Specifications). Replace closure plate if required.

Remove Balance Shaft (if equipped)

Remove balance shaft by pulling it straight out of crankcase.

Remove Camshaft and Valve Tappets

1. Remove camshaft by pulling it straight out of crankcase.
2. Remove valve tappets by pulling them straight out of crankcase. Mark their positions.

Automatic Compression Release (ACR)

ACR Operation Details

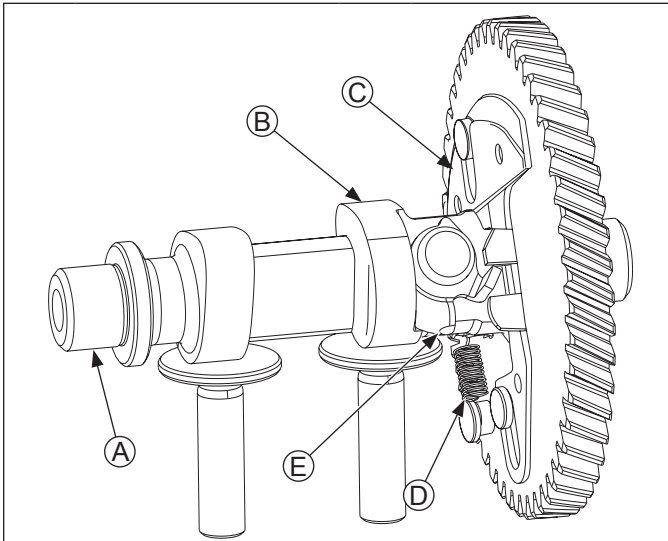

A	Camshaft	B	Exhaust Cam Lobe
C	Decompression Weight	D	Return Spring
E	Arm		

ACR mechanism consists of a spring-loaded arm and sliding pin mounted to camshaft. When engine is rotating at low cranking speeds, arm holds pin so it protrudes above heel of exhaust cam. This holds exhaust valve off of its seat during first part of compression stroke.

After engine speed increases centrifugal force causes spring-loaded arm to move outward causing pin to retract. When in this position pin has no effect on exhaust valve and engine operates at full compression and power.

Benefits

As a result of reduced compression at cranking speeds, several important benefits are obtained:

1. Manual (retractable) starting is much easier. Without ACR, manual starting would be virtually impossible.
2. Electric start models can use a smaller starter and battery more practical for application.
3. ACR eliminates need for a spark retard/advance mechanism. A spark retard/advance mechanism would be required on engines without ACR to prevent kickback which would occur during starting. ACR eliminates this kickback making manual starting safer.
4. Choke control setting is less critical with ACR. In event of flooding, excess fuel is blown out opened exhaust valve and does not hamper starting.
5. Engines with ACR start much faster in cold weather than engines without ACR.
6. Engines with ACR can be started with worn or fouled spark plugs. Engines without ACR are more difficult to start with those same spark plugs.

Disassembly/Inspection and Service

Inspection and Service

Dimension A

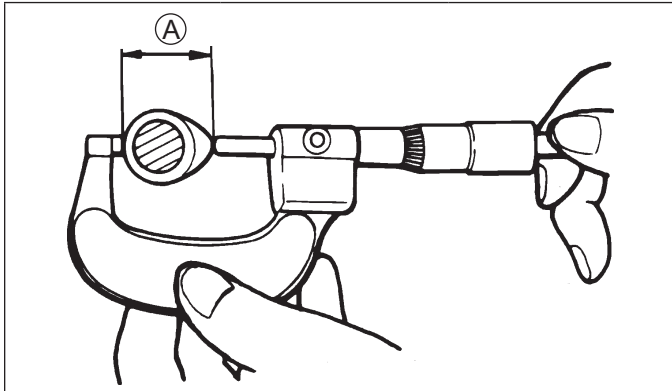

CH245/CH255 Cam Lobe

Valve	Dimension A	Service Limit
INTAKE	27.608 mm (1.087 in.)	27.354 mm (1.067 in.)
EXHAUST	27.770 mm (1.093 in.)	27.516 mm (1.083 in.)

CH260/CH270 Cam Lobe

Valve	Dimension A	Service Limit
INTAKE	27.787 mm (1.094 in.)	27.533 mm (1.084 in.)
EXHAUST	27.861 mm (1.097 in.)	27.607 mm (1.087 in.)

CH395 Cam Lobe

INTAKE	32.408 mm (1.276 in.)	32.154 mm (1.266 in.)
EXHAUST	32.12 mm (1.265 in.)	31.866 mm (1.255 in.)

CH440 Cam Lobe

INTAKE	32.286 mm (1.271 in.)	32.032 mm (1.261 in.)
EXHAUST	32.506 mm (1.280 in.)	32.252 mm (1.270 in.)

Dimension B

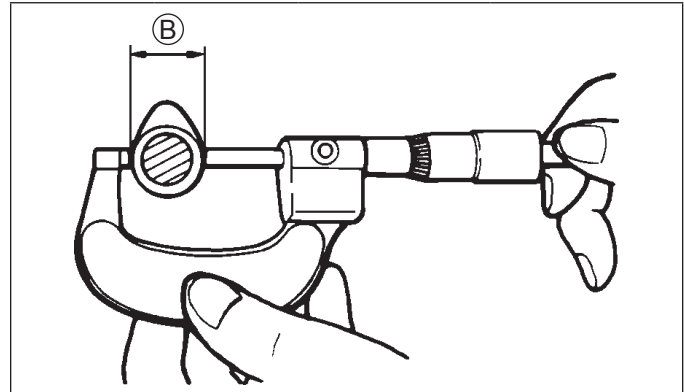

Cam Lobe Specifications

Engine Model	Valve	Dimension B	Service Limit
CH245, CH255	INTAKE	22.2 mm (0.874 in.)	21.8 mm (0.858 in.)
	EXHAUST	22.2 mm (0.874 in.)	21.8 mm (0.858 in.)
CH260, CH270	INTAKE	21.8 mm (0.858 in.)	21.5 mm (0.848 in.)
	EXHAUST	21.8 mm (0.858 in.)	21.5 mm (0.848 in.)
CH395	INTAKE	25.94 mm (1.021 in.)	25.68 mm (1.011 in.)
	EXHAUST	25.94 mm (1.021 in.)	25.68 mm (1.011 in.)
CH440	INTAKE	25.94 mm (1.021 in.)	25.68 mm (1.011 in.)
	EXHAUST	25.94 mm (1.021 in.)	25.68 mm (1.011 in.)

Dimension C

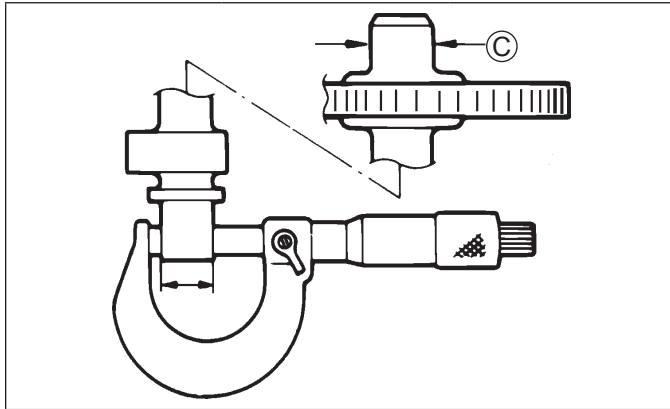

Camshaft Journal Specifications		
Engine Model	Dimension C	Limit
CH245, CH255	13.975 mm (0.5500 in.)	13.966 mm (0.5498 in.)
CH260, CH270	13.975 mm (0.5500 in.)	13.900 mm (0.5470 in.)
CH395, CH440	15.975 mm (0.6289 in.)	15.900 mm (0.6260 in.)

Inspect gear teeth of camshaft. If teeth are badly worn, chipped, or some are missing, replacement of camshaft will be necessary. If unusual wear or damage is evident on either lobe or mating tappet, camshaft and both tappets must be replaced. Check condition and operation of ACR mechanism.

Measure cam lobe profile, A and B, using an outside micrometer and compare with specifications listed.

Measure camshaft journals, C, which fit in ball bearings, for wear using a micrometer. Compare with specifications listed.

Remove Piston, Connecting Rod and Crankshaft

NOTE: If a carbon ridge is present at top of cylinder bore, use a ridge reamer to remove it before attempting to remove piston.

1. Remove screws securing end cap to connecting rod. Remove end cap. Carefully guiding connecting rod, slide piston and connecting rod from cylinder bore.
2. Remove crankshaft from crankcase.

Connecting Rods Inspection and Service

Check bearing area (big end) for excessive wear, score marks, running and side clearances (see Specifications and Tolerances). Replace rod and cap if scored or excessively worn.

Service replacement connecting rods are available in STD size and 0.25 mm (0.010 in.) undersize. 0.25 mm (0.010 in.) undersized rods have an identification marking on lower end of rod shank. Always refer to appropriate parts information to ensure correct replacements are used.

Piston and Rings Inspection

Scuffing and scoring of pistons and cylinder walls occurs when internal engine temperatures approach welding point of piston. Temperatures high enough to do this are created by friction, which is usually attributed to improper lubrication and/or overheating of engine.

Normally, very little wear takes place in piston boss-piston pin area. If original piston and connecting rod can be reused after new rings are installed, original pin can also be reused but new piston pin retainers are required. Piston pin is included as part of piston assembly – if pin boss in piston or pin are worn or damaged, a new piston assembly is required.

Ring failure is usually indicated by excessive oil consumption and blue exhaust smoke. When rings fail, oil is allowed to enter combustion chamber where it is burned along with fuel. High oil consumption can also occur when piston ring end gap is incorrect because ring cannot properly conform to cylinder wall under this condition. Oil control is also lost when ring gaps are not staggered during installation.

When cylinder temperatures get too high, lacquer and varnish collect on pistons causing rings to stick, which results in rapid wear. A worn ring usually takes on a shiny or bright appearance.

Scratches on rings and pistons are caused by abrasive material such as carbon, dirt, or pieces of hard metal. Detonation damage occurs when a portion of fuel charge ignites spontaneously from heat and pressure shortly after ignition. This creates 2 flame fronts, which meet and explode to create extreme hammering pressures on a specific area of piston. Detonation generally occurs from using low octane fuels.

Preignition, or ignition of fuel charge before timed spark can cause damage similar to detonation. Preignition damage is often more severe than detonation damage. Preignition is caused by a hot spot in combustion chamber such as glowing carbon deposits, blocked cooling fins, an improperly seated valve, or wrong spark plug(s).

Replacement pistons are available in STD bore size, and 0.25 mm (0.010 in.) oversize. Replacement pistons include new piston ring sets and new piston pins.

Replacement ring sets are also available separately for STD, and 0.25 mm (0.010 in.) oversize pistons. Always use new piston rings when installing pistons. Never use old rings.

Some important points to remember when servicing piston rings:

1. Cylinder bore must be deglazed before service ring sets are used.
2. If cylinder bore does not need reboring and if old piston is within wear limits and free of score or scuff marks, old piston may be reused.
3. Remove old rings and clean up grooves. Never reuse old rings.

Disassembly/Inspection and Service

- Before installing new rings on piston, place top 2 rings, each in turn, in its running area in cylinder bore and check end gap. Refer to Specifications.
- After installing new compression (top and middle) rings on piston, check piston-to-ring side clearance. Refer to Specifications. If side clearance is greater than specified, a new piston must be used.

Install New Piston Rings

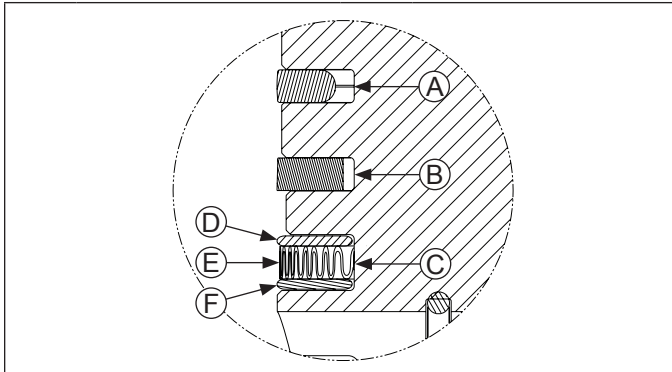

A	Top Compression Ring	B	Middle Compression Ring
C	Oil Control Ring	D	Top Rail
E	Expander Ring	F	Bottom Rail

Piston Ring Orientation

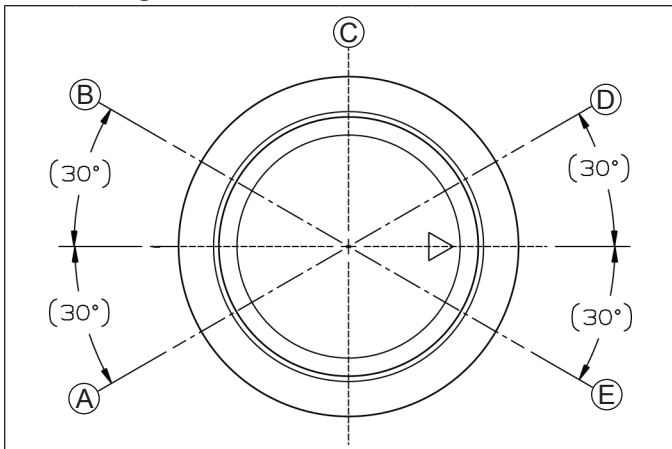

A	Middle Compression Ring Gap	B	Bottom Oil Rail Gap
C	Oil Ring Expander Gap	D	Top Oil Rail Gap
E	Top Compression Ring Gap		

NOTE: Rings must be installed correctly. Install bottom (oil control) ring first and top compression ring last.

Use a piston ring expander to install rings.

- Oil control ring (bottom groove): Install expander and then rails. Make sure ends of expander are not overlapped.

- Middle compression ring (center groove): Install center ring using a piston ring expander tool. Make sure identification mark is up or colored dye stripe (if contained) is left of end gap.
- Top compression ring (top groove): Install top ring using a piston ring expander tool. Make sure identification mark is up or colored dye stripe (if contained) is to left of end gap.

Crankshaft Inspection and Service

Inspect gear teeth of crankshaft. If teeth are badly worn, chipped, or some are missing, replacement of crankshaft will be necessary.

Inspect crankshaft bearing surfaces for scoring, grooving, etc. Measure running clearance between crankshaft journals and their respective bearing bores. Use an inside micrometer or telescoping gauge to measure inside diameter of both bearing bores in vertical and horizontal planes. Use an outside micrometer to measure outside diameter of crankshaft main bearing journals. Subtract journal diameters from their respective bore diameters to get running clearances. Check results against values in Specifications and Tolerances. If running clearances are within specification, and there is no evidence of scoring, grooving, etc., no further reconditioning is necessary. If bearing surfaces are worn or damaged, crankcase and/or closure plate will need to be replaced.

Inspect crankshaft keyways. If worn or chipped, replacement of crankshaft will be necessary. Inspect crankpin for score marks or metallic pickup. Slight score marks can be cleaned with crocus cloth soaked in oil. If wear limits are exceeded, as stated in Specifications, it will be necessary to replace crankshaft.

Remove Oil Sentry™ System

- Remove nut securing Oil Sentry™ lead wire grommet assembly in crankcase.
- Pull grommet assembly from inside of crankcase.
- Remove screws securing Oil Sentry™ float switch to crankcase. Remove float switch assembly.

Remove Governor Assembly (Mechanical Governor Only)

CH245, CH255, CH260, CH270

NOTE: Mark orientation of all parts as governor assembly is removed.

1. Remove cup and washer from governor gear.
2. Using a suitable drift, drive governor gear shaft from crankcase.
3. Remove hitch pin and washer from governor cross shaft.
4. Remove cross shaft from inside crankcase.

CH395

NOTE: Governor gear shaft is pressed into closure plate, and should not be removed.

NOTE: Take note of orientation of governor gear components.

1. Governor gear is located in closure plate. To remove governor gear, pull governor gear off shaft.
2. Remove hitch pin and washer from governor cross shaft.
3. Remove cross shaft from inside crankcase.

CH440

NOTE: Do not pry on gasket surface of closure plate, as this can cause damage and leakage.

NOTE: Take note of orientation of governor gear components.

NOTE: Governor gear shaft is pressed into closure plate, and should not be removed unless damaged.

1. Governor gear is located in closure plate. To remove governor gear, pry underneath gear to lift it off shaft.
2. If governor gear shaft is bent or damaged, remove it by pulling straight out.
3. Remove hitch pin and washer from governor cross shaft.
4. Remove cross shaft from inside crankcase.

Inspection

Inspect governor gear teeth. Replace gear if it is worn, chipped, or if any teeth are missing. Inspect governor weights. They should move freely in governor gear.

Remove Crankcase and Closure Plate Seals and Bearings

NOTE: Inspect bearings for signs of wear by rotating inner race and examine for marring or cracks. Check to make sure race moves easily and is not sloppy. If bearing is tight and rotates smoothly, removal is not necessary. If you feel any roughness or chattering or bearing is sloppy, it should be replaced.

1. Remove oil seal from crankcase.
2. Using a suitable press, push crankshaft bearing from crankcase.
3. Remove oil seal from closure plate.
4. Using a suitable press, push crankshaft bearing from closure plate.

Crankcase Inspection and Service Cylinder Bore Detail

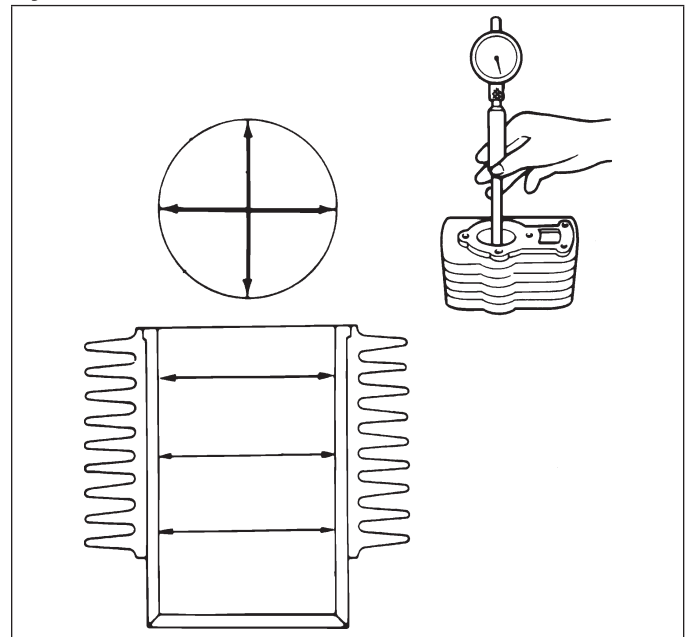

NOTE: A 0.25 mm (0.010 in.) oversize piston is available if resizing is selected. Initially, resize using a boring bar, then follow procedures for honing cylinder.

Check all gasket surfaces to make sure they are free of gasket fragments. Gasket surfaces must also be free of deep scratches or nicks.

Check cylinder bore for scoring. In severe cases, unburned fuel can cause scuffing and scoring of cylinder wall. It washes necessary lubricating oils off piston and cylinder wall. As raw fuel seeps down cylinder wall, piston rings make metal to metal contact with wall. Scoring of cylinder wall can also be caused by localized hot spots resulting from blocked cooling fins or from inadequate or contaminated lubrication.

If cylinder bore is badly scored, excessively worn, tapered, or out-of-round, resizing is necessary. Use an inside micrometer to determine amount of wear (refer to Specifications).

Disassembly/Inspection and Service

Honing

Crosshatch Detail

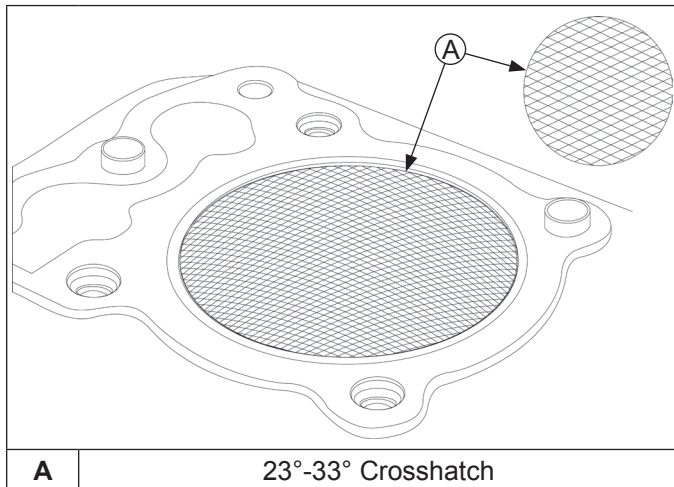

NOTE: Rehlko pistons are custom-machined to exacting tolerances. When over-sizing a cylinder, it should be machined exactly 0.25 mm (0.010 in.) over new diameter (Specifications and Tolerances). Oversize Rehlko replacement piston will then fit correctly.

While most commercially available cylinder hones can be used with either portable drills or drill presses, use of a low speed drill press is preferred as it facilitates more accurate alignment of bore in relation to crankshaft crossbore. Honing is best accomplished at a drill speed of about 250 RPM and 60 strokes per minute. After installing coarse stones in hone, proceed as follows:

1. Lower hone into bore and after centering, adjust stones so they are in contact with cylinder wall. Use of a commercial cutting-cooling agent is recommended.
2. With lower edge of each stone positioned even with lowest edge of bore, start drill and honing process. Move hone up and down while resizing to prevent formation of cutting ridges. Check size frequently.
3. When bore is within 0.064 mm (0.0025 in.) of desired size, remove coarse stones and replace them with burnishing stones. Continue with burnishing stones until bore is within 0.013 mm (0.0005 in.) of desired size and then use finish stones (220-280 grit) and polish bore to its final size. A crosshatch should be observed if honing is done correctly. Crosshatch should intersect at approximately 23°-33° off horizontal. Too flat an angle could cause rings to skip and wear excessively, and too steep an angle will result in high oil consumption.
4. After resizing, check bore for roundness, taper, and size. Use an inside micrometer, telescoping gauge, or bore gauge to take measurements. These measurements should be taken at 3 locations in cylinder – at top, middle, and bottom. Two measurements should be taken (perpendicular to each other) at each location.

Clean Cylinder Bore After Honing

Proper cleaning of cylinder walls following boring and/or honing is very critical to a successful overhaul. Machining grit left in cylinder bore can destroy an engine in less than one hour of operation after a rebuild.

Final cleaning operation should always be a thorough scrubbing with a brush and hot, soapy water. Use a strong detergent capable of breaking down machining oil while maintaining a good level of suds. If suds break down during cleaning, discard dirty water and start again with more hot water and detergent. After scrubbing, rinse cylinder with very hot, clear water, dry it completely, and apply a light coating of engine oil to prevent rusting.

Measuring Piston-to-Bore Clearance

Piston Details

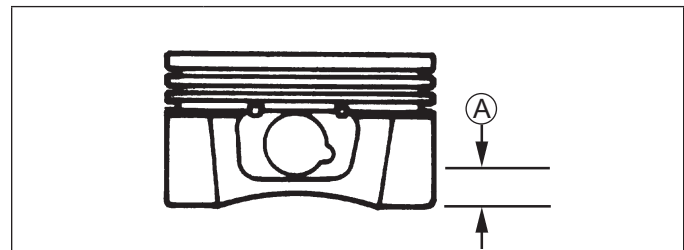

Model	Dimension A
CH245, CH255	15 mm (0.5905 in.)
CH260, CH270	21.8-22.2 mm (0.8583-0.8740 in.)
CH395	17.8-18.2 mm (0.7008-0.7165 in.)
CH440	29.8-30.2 mm (1.1732-1.1890 in.)

NOTE: Do not use a feeler gauge to measure piston-to-bore clearance, it will yield inaccurate measurements. Always use a micrometer.

Before installing piston into cylinder bore, it is necessary that clearance be accurately checked. This step is often overlooked, and if clearances are not within specifications, engine failure will usually result.

Use following procedure to accurately measure piston-to-bore clearance:

1. Use a micrometer and measure diameter of piston above bottom of piston skirt and perpendicular to piston pin.
2. Use an inside micrometer, telescoping gauge, or bore gauge and measure cylinder bore. Take measurement approximately 7.0 mm (0.2760 in.) below top of bore and perpendicular to piston pin.
3. Piston-to-bore clearance is difference between bore diameter and piston diameter (step 2 minus step 1).

CH245/CH255 Crankshaft/Camshaft/Closure Plate Components

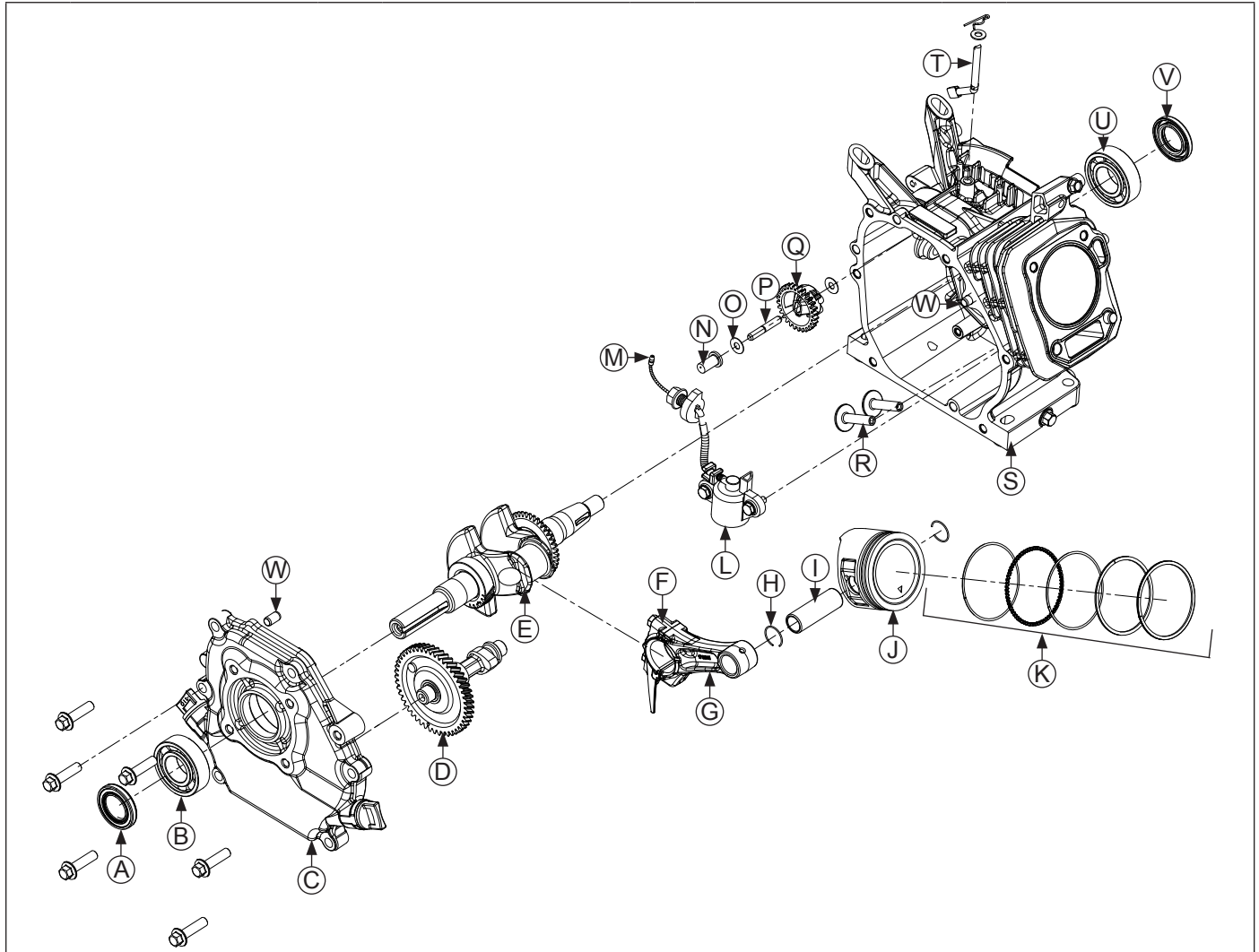

A	Closure Plate Oil Seal	B	Closure Plate Bearing	C	Closure Plate	D	Camshaft
E	Crankshaft	F	Connecting Rod End Cap	G	Connecting Rod	H	Piston Pin Retainer
I	Piston Pin	J	Piston	K	Piston Ring Set	L	Oil Sentry™ Float Switch
M	Oil Sentry™ Wire	N	Governor Cup	O	Governor Washer	P	Governor Shaft
Q	Governor Gear	R	Tappet	S	Crankcase	T	Governor Cross Shaft
U	Crankcase Bearing	V	Crankcase Oil Seal	W	Dowel		

Reassembly

CH260/CH270 Crankshaft/Camshaft/Closure Plate Components

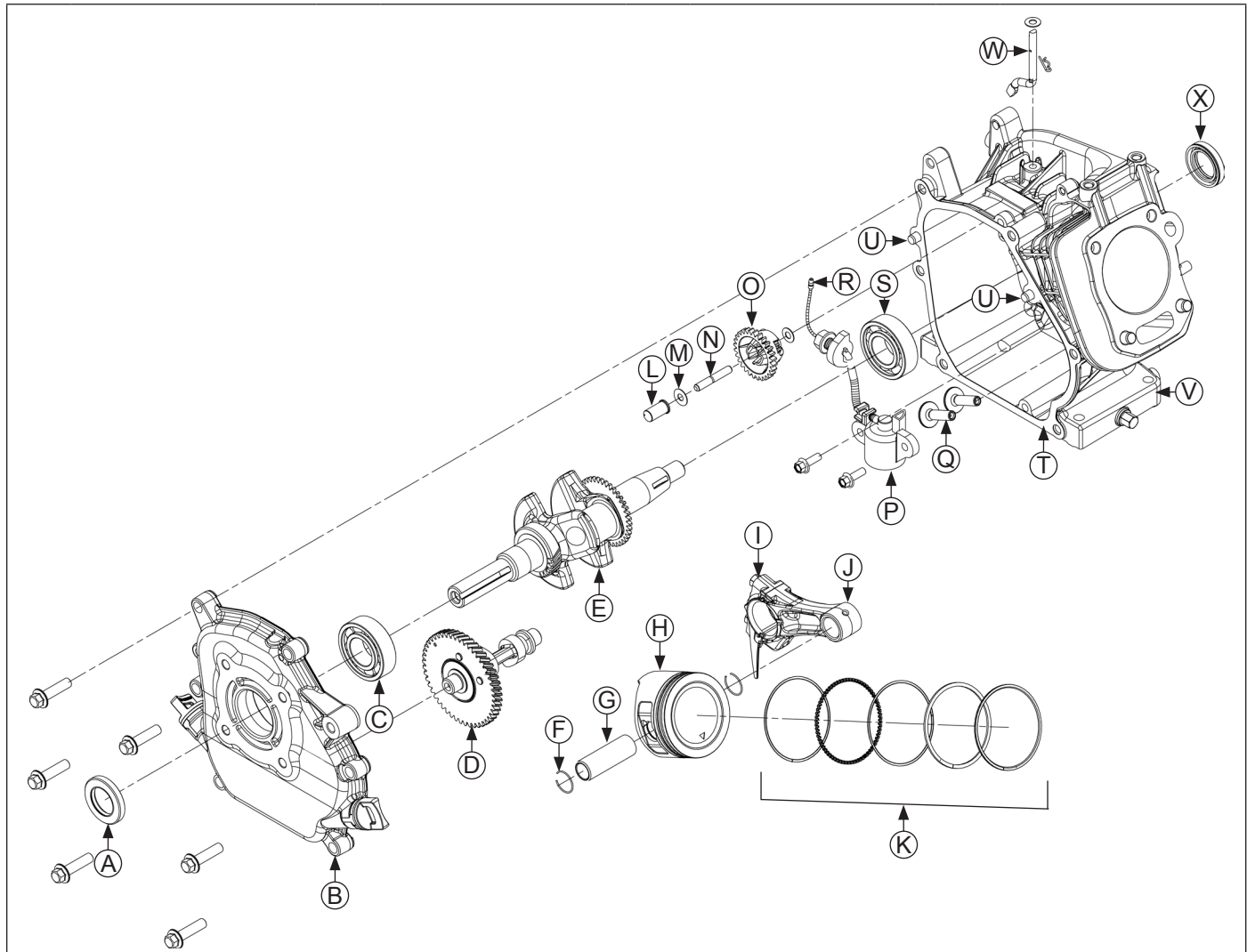

A	Closure Plate Oil Seal	B	Closure Plate	C	Closure Plate Bearing	D	Camshaft
E	Crankshaft	F	Piston Pin Retainer	G	Piston Pin	H	Piston
I	Connecting Rod End Cap	J	Connecting Rod	K	Piston Ring Set	L	Governor Cup
M	Governor Washer	N	Governor Shaft	O	Governor Gear	P	Oil Sentry™ Float Switch
Q	Tappet	R	Oil Sentry™ Wire	S	Crankcase Bearing	T	Closure Plate Gasket
U	Dowel	V	Crankcase	W	Governor Cross Shaft	X	Crankcase Oil Seal

CH395/CH440 Crankshaft/Camshaft/Closure Plate Components

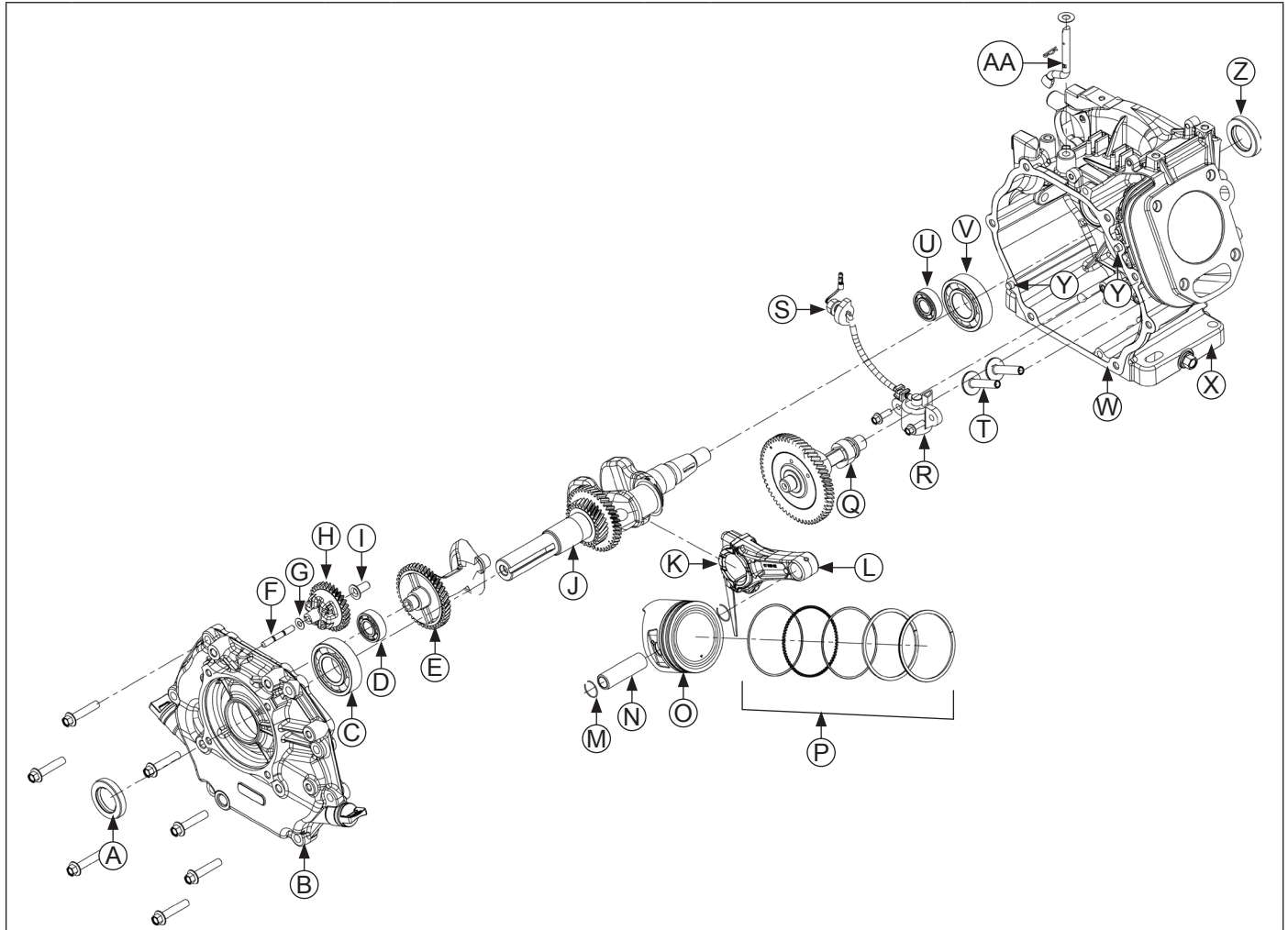

A	Closure Plate Oil Seal	B	Closure Plate	C	Closure Plate Bearing	D	Closure Plate Balance Shaft Bearing
E	Balance Shaft	F	Governor Shaft	G	Governor Washer	H	Governor Gear
I	Governor Cup	J	Crankshaft	K	Connector Rod End Cap	L	Connector Rod
M	Piston Pin Retainer	N	Piston Pin	O	Piston	P	Piston Ring Set
Q	Camshaft	R	Oil Sentry™ Float Switch	S	Oil Sentry™ Wire	T	Tappet
U	Crankcase Balance Shaft Bearing	V	Crankcase Bearing	W	Closure Plate Gasket	X	Crankcase
Y	Dowel	Z	Crankcase Oil Seal	AA	Governor Cross Shaft		

Reassembly

NOTE: Make sure engine is assembled using all specified torque values, tightening sequences, and clearances. Failure to observe specifications could cause severe engine wear or damage. Always use new gaskets.

Install Crankcase Bearings and Oil Seals

Details

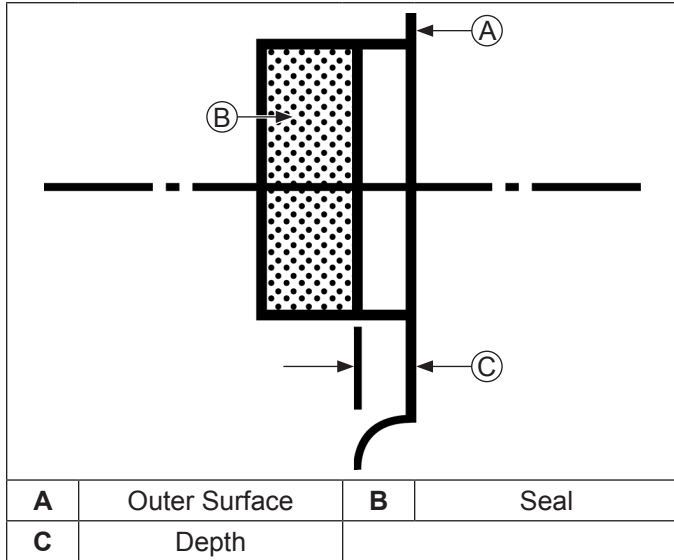

NOTE: Oil bearings liberally with engine oil when installing.

NOTE: In steps 3 and 4, position oil seals with manufacturer's identification marks visible and facing you.

1. Make sure there are no nicks, burrs, or damage in bores for bearings. Crankcase and closure plate must be clean.
2. Use an arbor press to make sure bearings are installed straight into their respective bores, until fully seated.
3. Using an appropriate seal driver, install oil seal into closure plate to depth specified below.
Install to a depth of:
CH245, CH255, CH260, CH270 5.5 mm (0.217 in.) from outer surface
CH395 7.0 mm (0.276 in.) from outer surface
CH440 8.2 mm (0.323 in.) from outer surface
4. Using an appropriate seal driver, install oil seal into crankcase to depth specified below.
Install to a depth of:
CH245, CH255 1.5-2.0 mm (0.059-0.079 in.)
CH260, CH270, CH440 0.0-1.0 mm (0.0-0.039 in.) from outer surface
CH395 2.0 mm (0.079 in.) from outer surface
5. Apply a light coating of lithium grease to seal lips after installing.

Install Governor Assembly (Mechanical Governor Only)

CH245, CH255, CH260/CH270

Governor Details

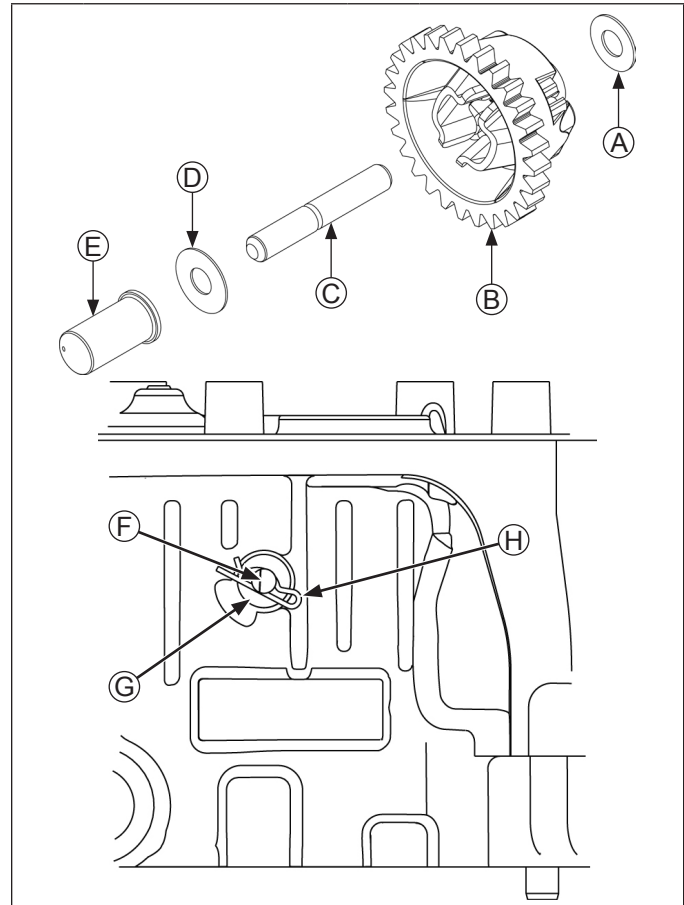

A	Thrust Washer	B	Governor Gear
C	Shaft	D	Washer
E	Cup	F	Governor Cross Shaft Index Flat
G	Thrust Washer	H	Hitch Pin

1. Install governor shaft through gear and add thrust washer to shaft.
2. Install governor gear assembly into crankcase using a press, or a drift with light taps, until tip of shaft is below machined gasket surface of crankcase to depth specified. Install washer and cup on shaft.
CH245, CH255 78.2 mm (3.079 in.)
CH260, CH270 78.862 mm (3.105 in.)
3. Install one thrust washer onto governor cross shaft and slide shaft up through inside of crankcase.
4. Install second flat washer onto shaft. Position shaft so flat index end of shaft faces left (9 o'clock position) and install hitch pin so end of pin comes in contact with raised boss on housing, limiting inward movement of shaft.

CH395 Governor Details

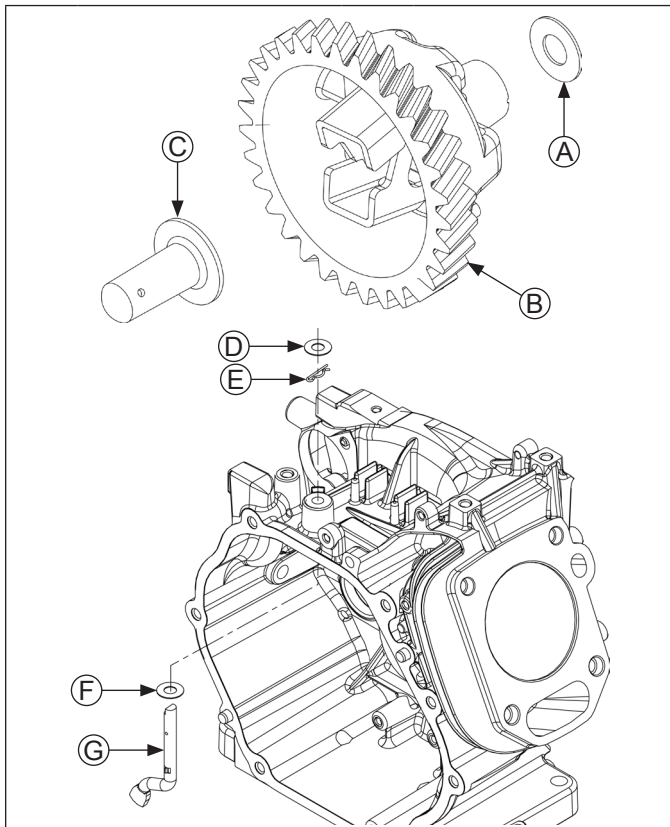

A	Thrust Washer	B	Governor Gear
C	Pin Rim	D	Washer
E	Hitch Pin	F	Thrust Washer
G	Governor Cross		

NOTE: Governor gear shaft is pressed into closure plate and should not be removed.

1. Assemble governor gear pin into governor gear so pin rim is held in place by weight retainers.
2. Place thrust washer on governor gear shaft in closure plate. Push governor gear onto shaft.
3. Install one thrust washer onto governor cross shaft and slide shaft up through inside of crankcase.
4. Install second flat washer onto shaft. Position shaft so flat index end of shaft faces left (9 o'clock position) and insert hitch pin from PTO side.

CH440 Governor Details

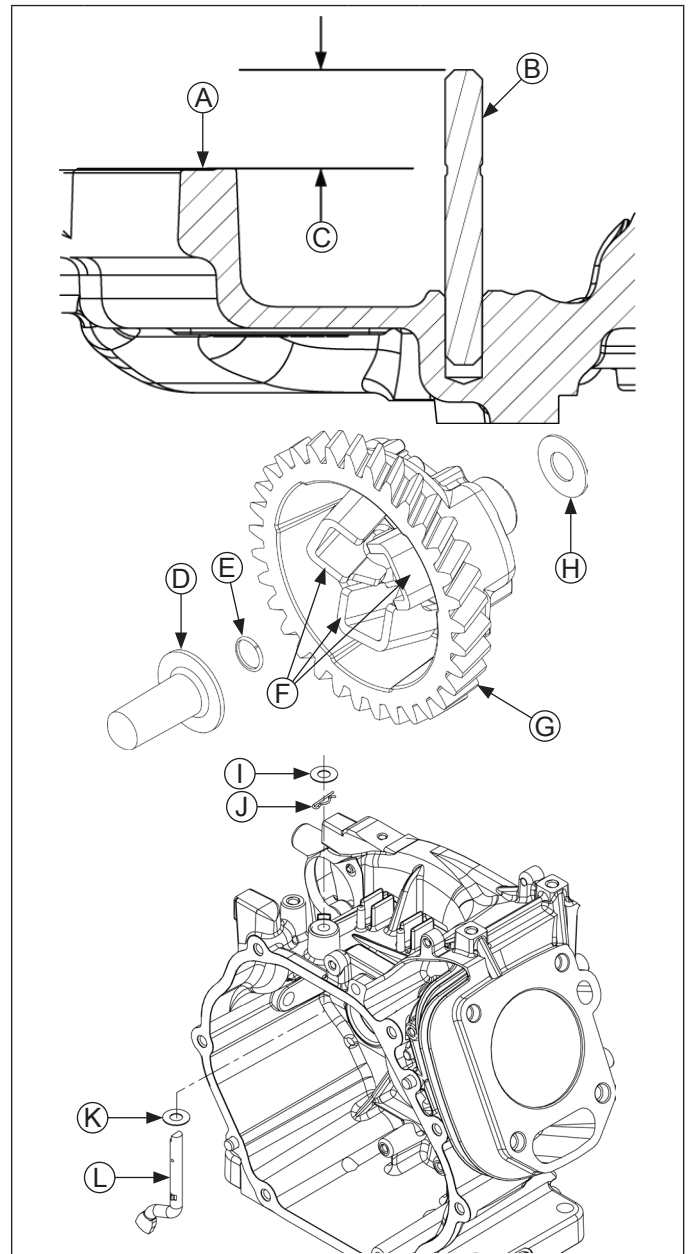

A	Closure Plate Sealing Surface	B	Governor Gear Shaft
C	Height	D	Pin Rim
E	Ring	F	Weights
G	Governor Gear	H	Thrust Washer
I	Washer	J	Hitch Pin
K	Thrust Washer	L	Governor Cross

1. If shaft was removed in disassembly, use an arbor press to install new shaft to a height of 16.025 mm (0.6309 in.) from closure plate sealing surface.
2. Place washer onto shaft, then place governor gear onto shaft.
3. Press a new ring onto shaft about 1/8 in.

Reassembly

4. Pull governor gear up until it makes contact with ring, then place pin in cup, retaining rim with weights.
5. Push pin down, snapping ring into shaft groove.
6. Pull up slightly on governor gear to ensure assembly is installed correctly.
7. Install one thrust washer onto governor cross shaft and slide shaft up through inside of crankcase.
8. Install second flat washer onto shaft. Position shaft so flat index end of shaft faces to left (9 o'clock position) and insert hitch pin from PTO side.

Install Oil Sentry™ System

1. Mount Oil Sentry™ float switch into crankcase housing using two M6x18 screws and torque to 8 N·m (71 in. lb.).
2. Route wire lead grommet assembly through crankshaft housing.
3. Install nut on grommet assembly external stud and torque to 10 N·m (89 in. lb.).

Install Crankshaft

Carefully slide flywheel end of crankshaft through main ball bearing and seal.

Install Connecting Rod with Piston and Rings

Connecting Rod Details

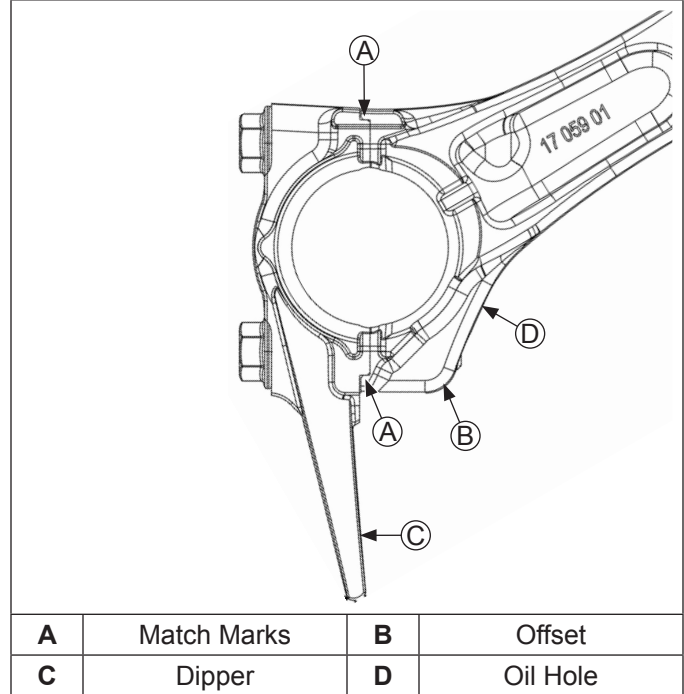

1. Make sure these are correct before installing.
 - a. Locating mark on piston is down.
 - b. Connecting rod offset is down and oil hole is in 4 o'clock position shown. Match marks should align as shown with dipper down.
2. If piston rings were removed, see Disassembly/Inspection and Service procedure to install rings.
3. Lubricate cylinder bore, piston, piston pin, and piston rings with engine oil. Compress rings using a piston ring compressor.
4. Lubricate crankshaft journal and connecting rod bearing surfaces with engine oil.
5. Ensure ▼ stamping on piston is facing down toward base of engine. Use a hammer handle or rounded wood dowel and gently tap piston into cylinder as shown. Be careful oil ring rails do not spring free between bottom of ring compressor and top of cylinder.
6. Install connecting rod cap to connecting rod so dipper is down, and match marks are aligned.
7. Torque both screws in increments to:
 - CH245, CH255, CH260, CH270 12.4 N·m (111 in. lb.)
 - CH395, CH440 20 N·m (177 in. lb.)

Install Balance Shaft (if equipped)

1. Position crankshaft so timing mark on larger crankgear is in 8 o'clock position.
2. Install balance shaft, aligning timing mark with timing mark on larger crankgear.

Install Valve Tappets and Camshaft

Timing Mark Detail

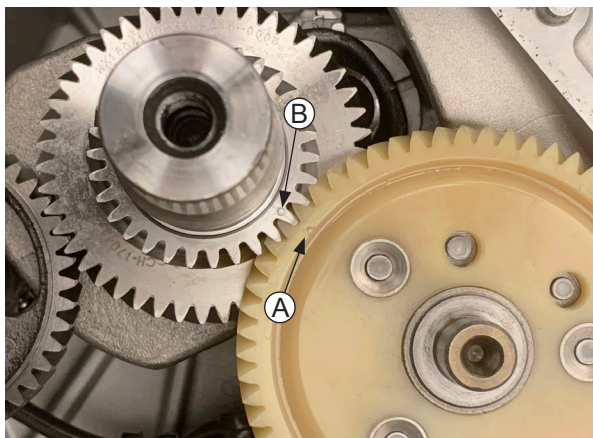
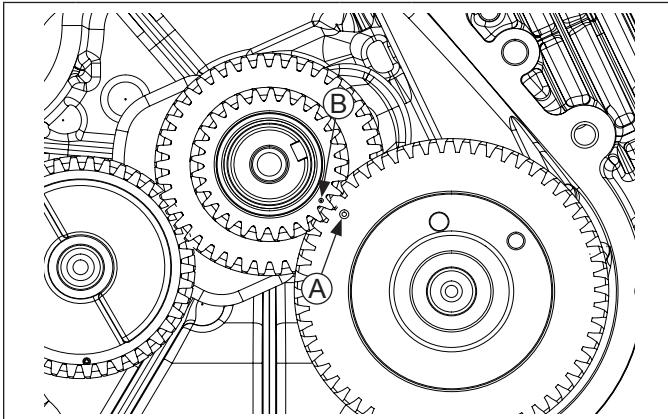

A	Camshaft Gear Timing Mark	B	Camshaft Drive Gear on Crankshaft Timing Mark
----------	------------------------------	----------	---

1. Lubricate face and stem of each tappet with engine oil. Install each into their respective bores.
2. Lubricate camshaft bearing surfaces and cam lobes as well as camshaft bore in crankcase with engine oil.
3. Rotate crankshaft to TDC so timing mark (dimple) on smaller crankgear is in 4 o'clock position. Install camshaft into crankcase, aligning timing marks on two gears.
4. Install original shims on crankshaft and camshaft.

Install Closure Plate

CH245/CH255/CH260/CH270 Torque Sequence

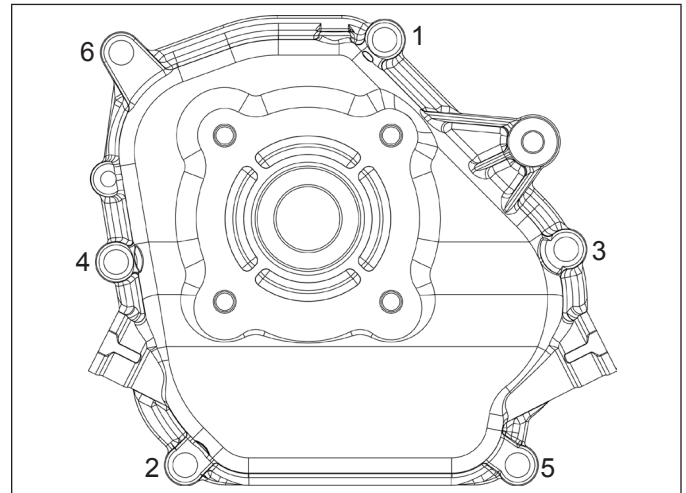

CH395/CH440 Torque Sequence

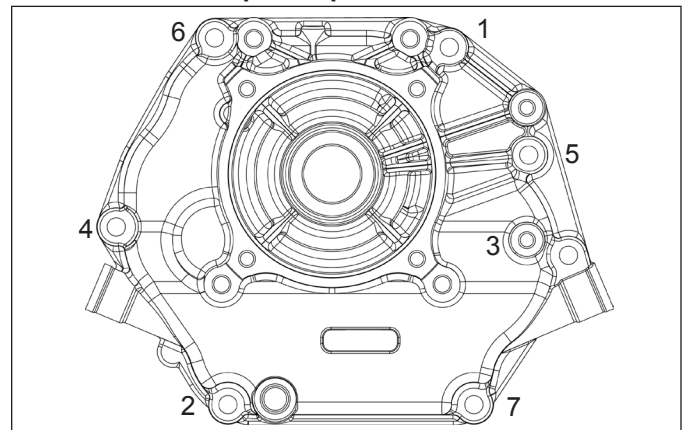

CH245/255 Sealant Pattern

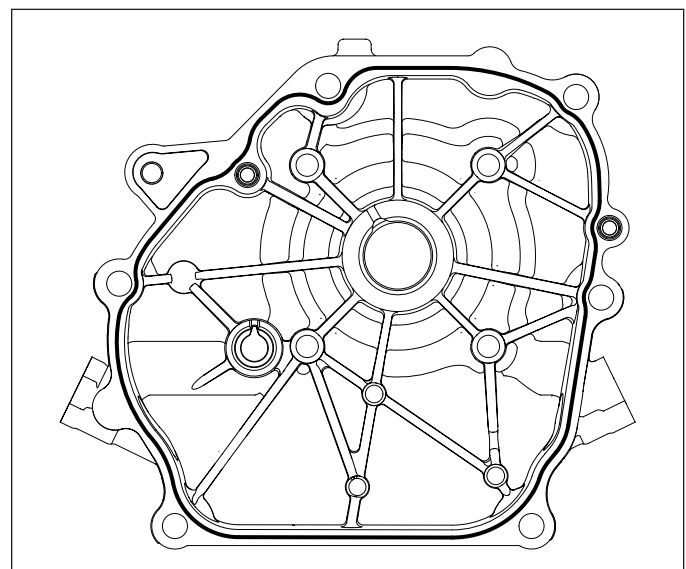

Reassembly

CH260/270 Sealant Pattern

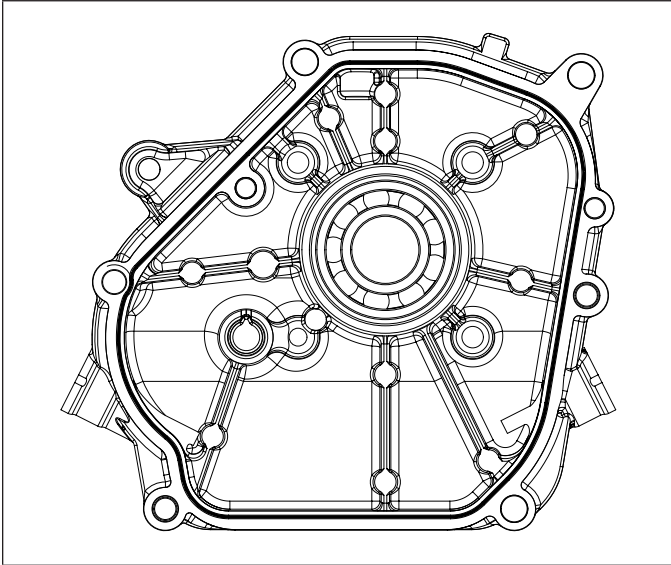

CH395 Sealant Pattern

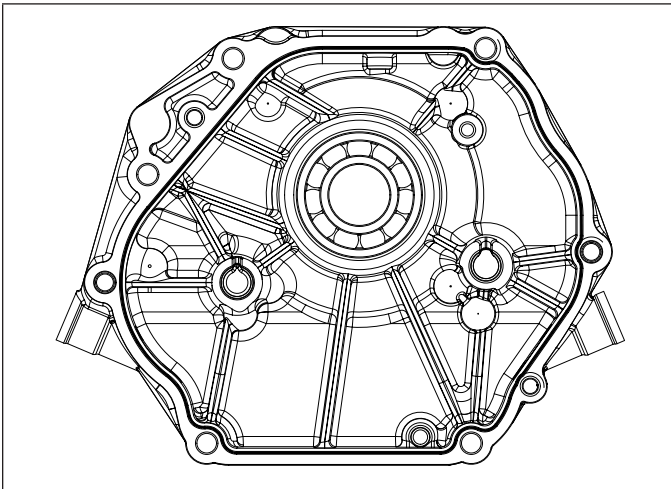

CH440 Sealant Pattern

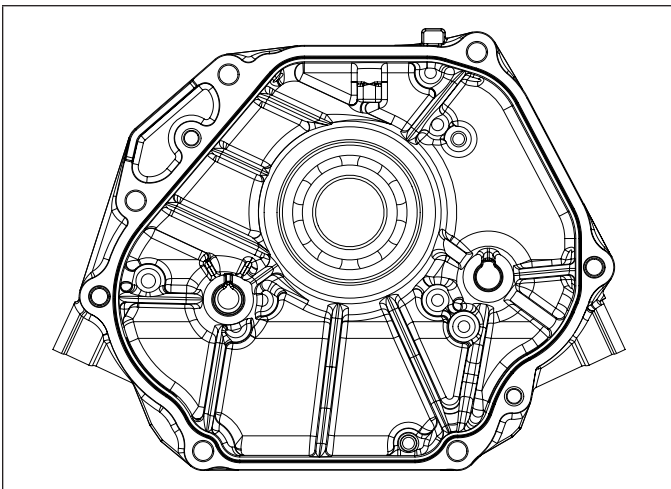

NOTE: Make sure governor lever is against cup on governor gear assembly.

NOTE: Some engines have a closure plate gasket; some engines use RTV to secure closure plate to crankcase.

1. Check to make sure sealing surfaces of crankcase and closure plate are clean, dry, and free of nicks/burrs.
2. Install two dowel pins into crankcase (if removed) as noted in disassembly.
3. **CLOSURE PLATE GASKET:** Install new closure plate gasket (dry) onto dowel pins.
RTV: Refer to Tools and Aids for a listing of approved sealants. Always use fresh sealant. Using outdated sealant can result in leakage. Using sealant pattern, apply a 1.5 mm (1/16 in.) bead of sealant to sealing surface of closure plate.
4. Install closure plate to crankcase. Carefully seat ends of camshaft and balance shaft into their mating bearings. Rotate crankshaft slightly to help engage governor gear teeth.
5. Install screws securing closure plate to crankcase. Torque screws in sequence shown to 24 N·m (212 in. lb.).

Install Gear Reduction Assembly (if equipped)

Refer to Gear Reduction System for disassembly, inspection, and reassembly procedures.

CH245/CH255 Flywheel/Ignition Components

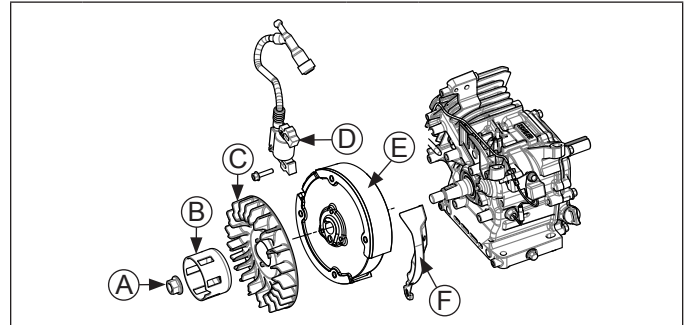

A	Flywheel Retaining Nut	B	Drive Cup
C	Flywheel Fan	D	Ignition Module
E	Flywheel	F	Flywheel Shield

CH260/CH270 Flywheel/Ignition Components

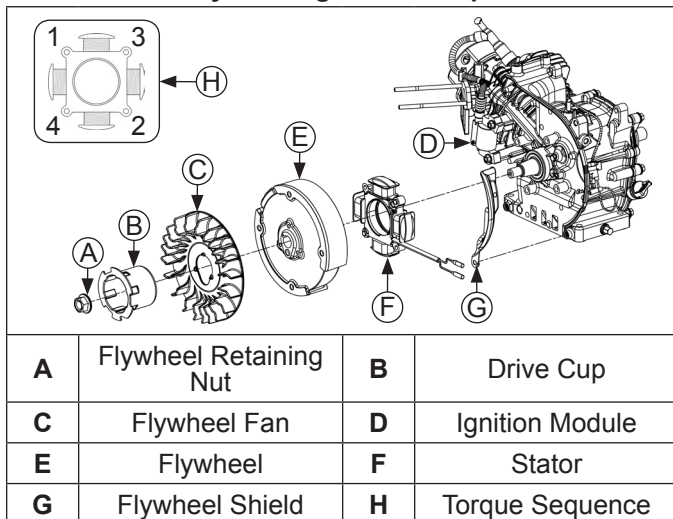

CH395/CH440 Flywheel/Ignition Components

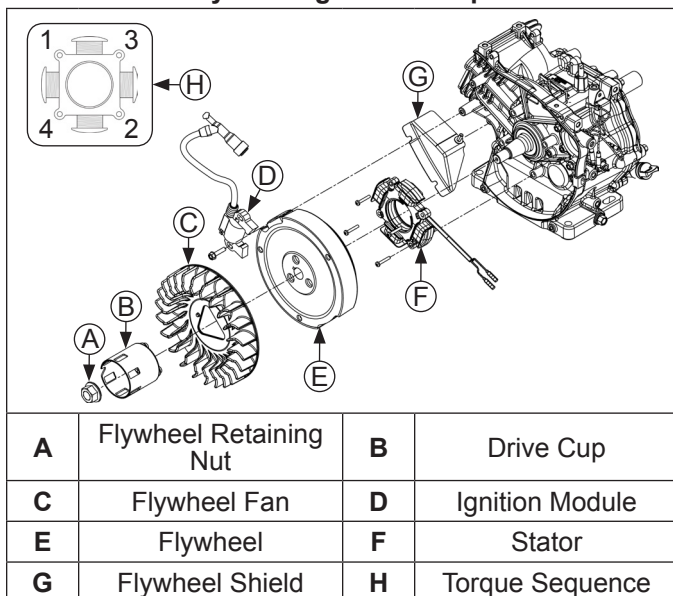

Install Stator (if equipped)

1. Position stator aligning mounting holes so leads are in 3 o'clock position.
2. Install and torque screws to 10 N·m (89 in. lb.) in sequence of 1, 2, 3, 4 and then torque 1 again.
3. Route stator leads along crankcase and out notch on side.
4. Position bracket over stator leads and install and torque screw to 10 N·m (89 in. lb.).

Install Flywheel

	CAUTION
	Damaging Crankshaft and Flywheel can cause personal injury.
Using improper procedures can lead to broken fragments. Broken fragments could be thrown from engine. Always observe and use precautions and procedures when installing flywheel.	

NOTE: Before installing flywheel make sure crankshaft taper and flywheel hub bore are clean, dry, and completely free of lubricants. Presence of lubricants can cause flywheel to be overstressed and damaged when nut is torqued to specification.

NOTE: Make sure flywheel key is installed properly in keyway. Flywheel can become cracked or damaged if key is not installed properly.

NOTE: CH395, CH440 has a boss on fan and a hole in drive cup.

1. Install woodruff key into keyway of crankshaft. Make sure key is properly seated and parallel with taper of shaft.
2. Install flywheel onto crankshaft, being careful not to shift position of woodruff key.
3. Install flywheel shield and secure with one screw (CH260 and CH270 only).
4. Install fan bosses into matching holes in flywheel.
5. Position drive cup on flywheel, engaging boss on its base with corresponding hole in flywheel. Hold in position and install nut. Finger tighten to keep cup indexed.
6. Use a flywheel holding tool and torque wrench to tighten flywheel nut. Torque nut to:
 CH245, CH255, CH260, CH270 74 N·m (655 in. lb.)
 CH395, CH440 113 N·m (1000 in. lb.)

Reassembly

Install Ignition Module

NOTE: Ensure ignition module is correctly oriented.

NOTE: On engines with a fuel shut-off solenoid, secure ground lead ring terminal on ignition module screw as noted in disassembly.

1. Turn flywheel so magnet is away from location where ignition module will be installed.
2. Install ignition module loosely to bosses with screws. Move module as far away from flywheel as possible, then tighten screws just enough to hold it in position.
3. Rotate flywheel until magnet is under one leg of ignition module.
4. Insert a 0.254 mm (0.010 in.) flat feeler gauge between leg of module and magnet. Loosen nearest screw allowing magnet to draw module against feeler gauge. Push against module to hold leg tight against feeler gauge while tightening screw.
5. Rotate flywheel until magnet is under other leg of module. Loosen nearest screw allowing magnet to draw module against feeler gauge. Push against module to hold leg tight against feeler gauge while tightening screw.
6. Torque first screw, then second screw. Go back and torque first screw one more time. Torque both module screws to 10 N·m (89 in. lb.).
7. Rotate flywheel back and forth, checking to make sure magnet does not strike module.
8. Connect kill wire to ignition module bottom blade terminal and route wire lead to top of crankcase.

CH245/CH255 Cylinder Head Components

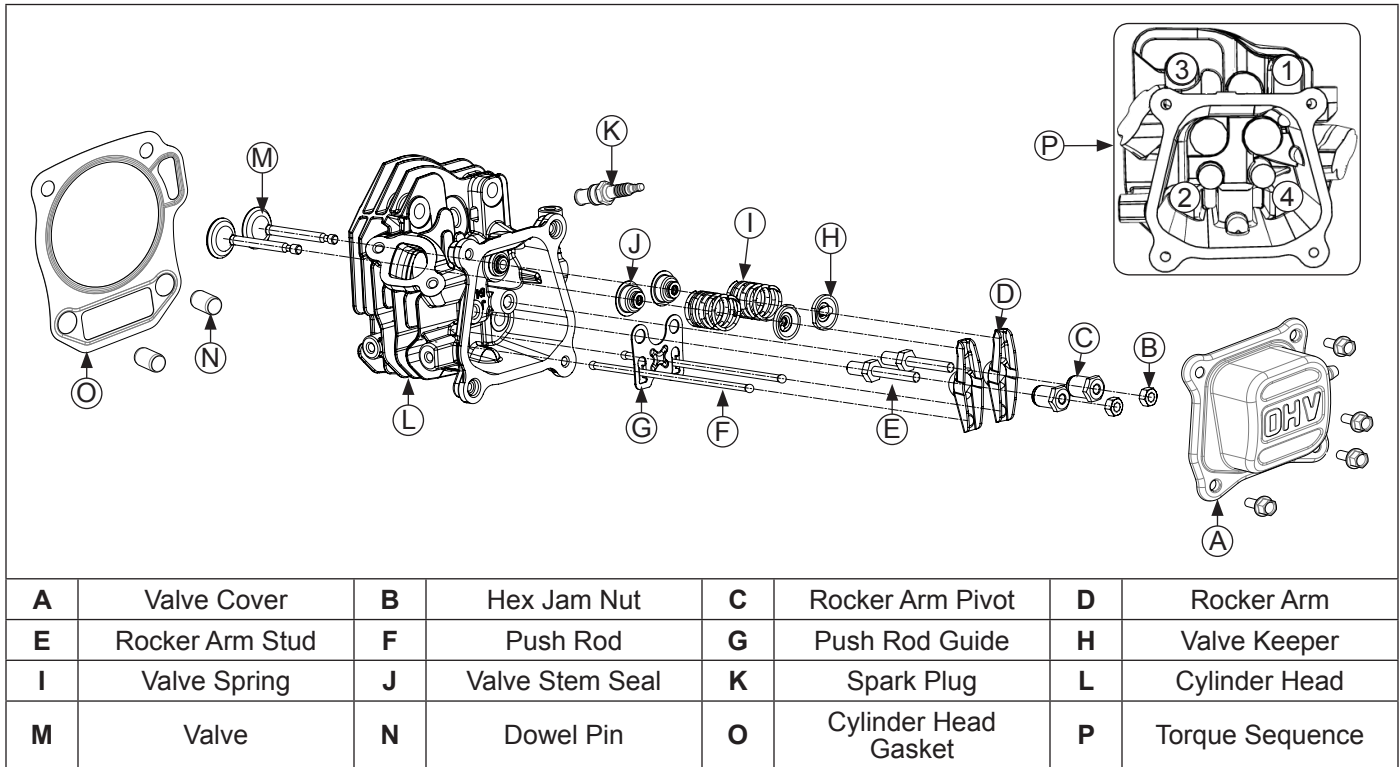

CH260-CH440 Cylinder Head Components

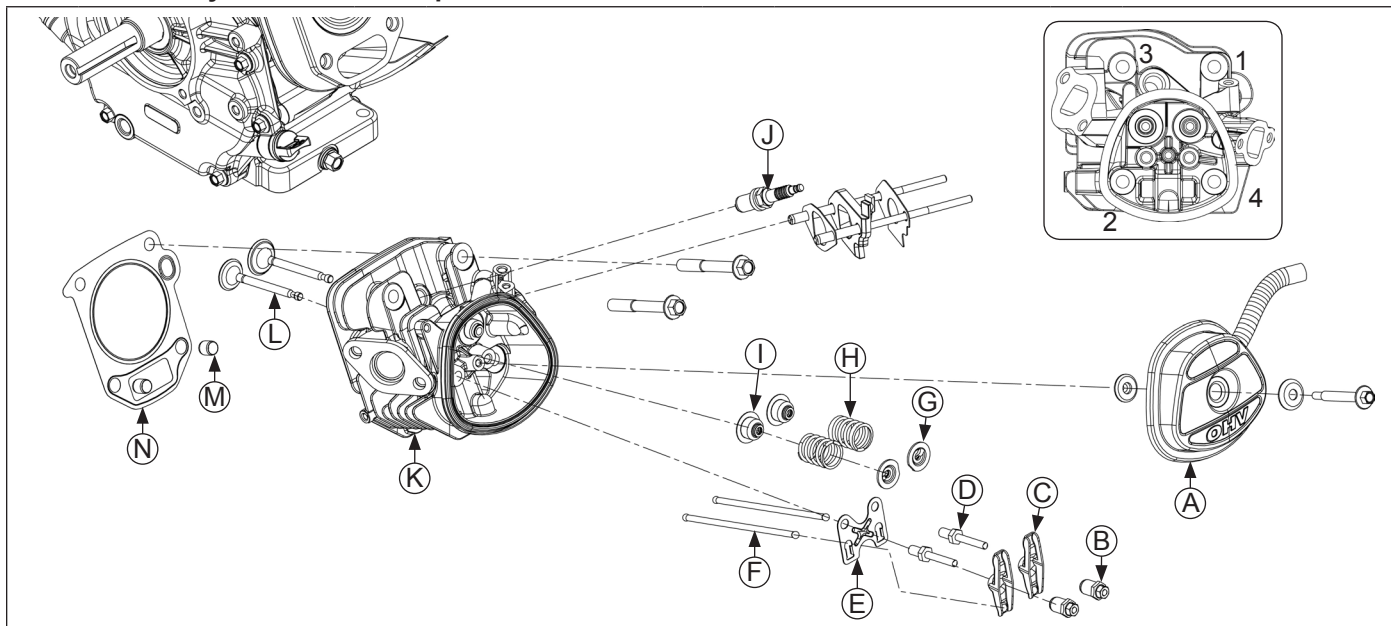

A	Valve Cover	B	Adjuster Nut	C	Rocker Arm	D	Rocker Arm Stud
E	Push Rod Guide	F	Push Rod	G	Valve Keeper	H	Valve Spring
I	Valve Stem Seal	J	Spark Plug	K	Cylinder Head	L	Valve
M	Dowel Pin	N	Cylinder Head Gasket	O	Torque Sequence		

Assemble Cylinder Head

NOTE: Engine utilizes valve stem seals on valves. Always use a new seal when valves are installed in cylinder head. Never reuse old seals.

1. Install valves into their respective positions.
2. Install new valve seals on stem of valves.
3. Install valve springs and retainers into their respective locations in cylinder head. Support valve heads from underneath. Using hand pressure, compress each valve spring and slide each retainer onto valve stem to lock in place.

Install Cylinder Head

1. Check to make sure there are no nicks or burrs on sealing surfaces of cylinder head or crankcase.
2. Rotate crankshaft to position piston at TDC on compression stroke.
3. Install dowel pins into recesses around cylinder head bolt holes as noted in disassembly.
4. Install a new cylinder head gasket.

CH245, CH255, CH260, CH270, CH395

5. Install cylinder head and start screws. Torque screws in increments using sequence shown. Torque screws following table.

Model	Initial Torque	Final Torque
CH245,CH255 CH260,CH270	12 N·m (106 in. lb.)	24 N·m (212 in. lb.)
CH395	18 N·m (159 in. lb.)	36 N·m (319 in. lb.)

CH440

5. Apply clean engine oil under head of each cylinder head screw. Install cylinder head and start screws. Finger tighten screws, then torque screws in increments using sequence shown. Torque screws following table.

Model	Initial Torque	Final Torque
CH440	25 N·m (221 in. lb.)	57.5 N·m (509 in. lb.)

Reassembly

Install Push Rods and Rocker Arms

NOTE: Push rods should always be installed in original location.

1. Identify proper position of each push rod. Dip ends of push rods in engine oil and install them in their respective locations, seating each into tappet socket.
2. Install push rod guide plate, aligning holes for rocker arm studs. Screw in rocker arm studs and torque to 13.6 N·m (120 in. lb.).
3. Assemble rocker arms, adjusters, and locknuts onto studs and push rods. Finger tighten rocker arm pivot jam locknuts.
4. Adjust valve tappet clearance as follows:
 - a. Make sure piston is still at top of compression stroke.
 - b. Insert a flat feeler gauge between rocker arm and valve stem. Recommended valve to rocker arm clearance for both intake and exhaust is 0.076-0.127 mm (0.003-0.005 in.)(Cold).
 - c. Adjust clearance as required by loosening locknut and turning adjuster.
Turn clockwise to decrease clearance.
Turn counterclockwise to increase clearance.
 - d. Hold adjuster from turning and tighten locknut. Torque locknut to 10 N·m (89 in. lb.).
 - e. Recheck clearance is correct.
5. Set gap of a new spark plug to 0.76 mm (0.030 in.).
6. Install spark plug in cylinder head and torque to 27 N·m (20 ft. lb.).

Install Valve Cover

CH245/CH255 Valve Cover Torque Sequence

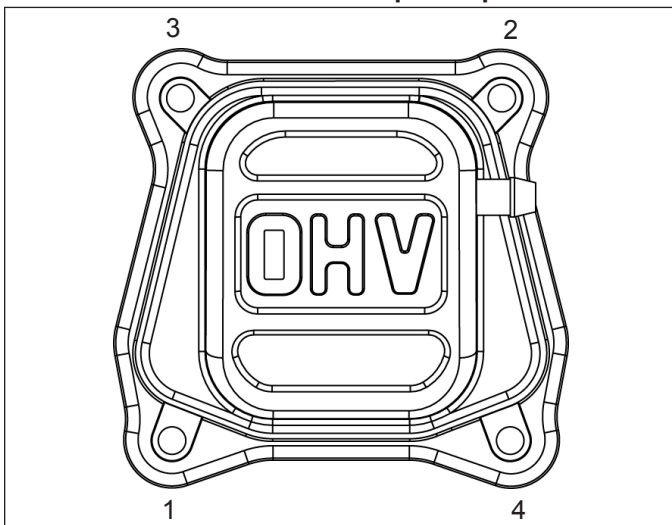

CH245/CH255 Valve Cover with RTV

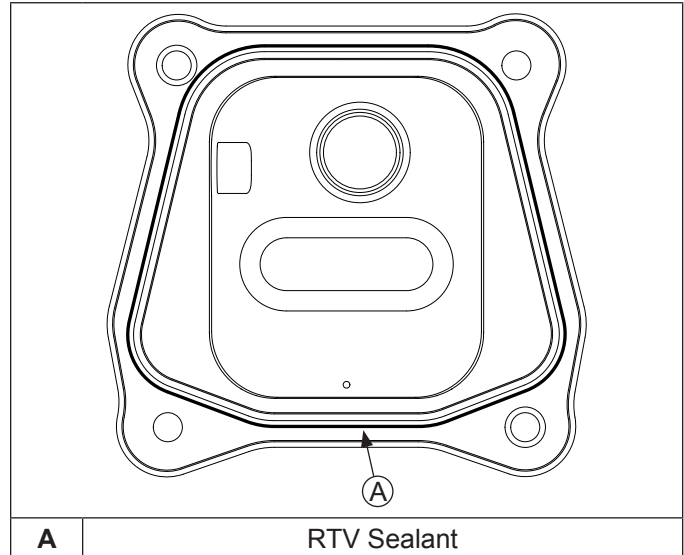

CH245/CH255

NOTE: Always use fresh sealant. Using outdated sealant can result in leakage. Refer to Tools and Aids for important information on sealant dispenser.

NOTE: To ensure proper adhesion of sealant to both surfaces, perform step 3 immediately (5 minutes maximum) after application of RTV.

1. Prepare sealing surface of cylinder head and valve cover.
2. Apply a 1.5 mm (1/16 in.) bead of sealant to valve cover as shown.
3. Position cover on cylinder head and start mounting screws.
4. Torque screws to 8.0 N·m (71 in. lb.) using sequence shown.

CH260-CH440

1. Install a new valve cover gasket onto valve cover.
2. Position valve cover/gasket assembly on head. Install screw and torque to 10 N·m (89 in. lb.).

CH245/CH255 Blower Housing/Control Panel Components

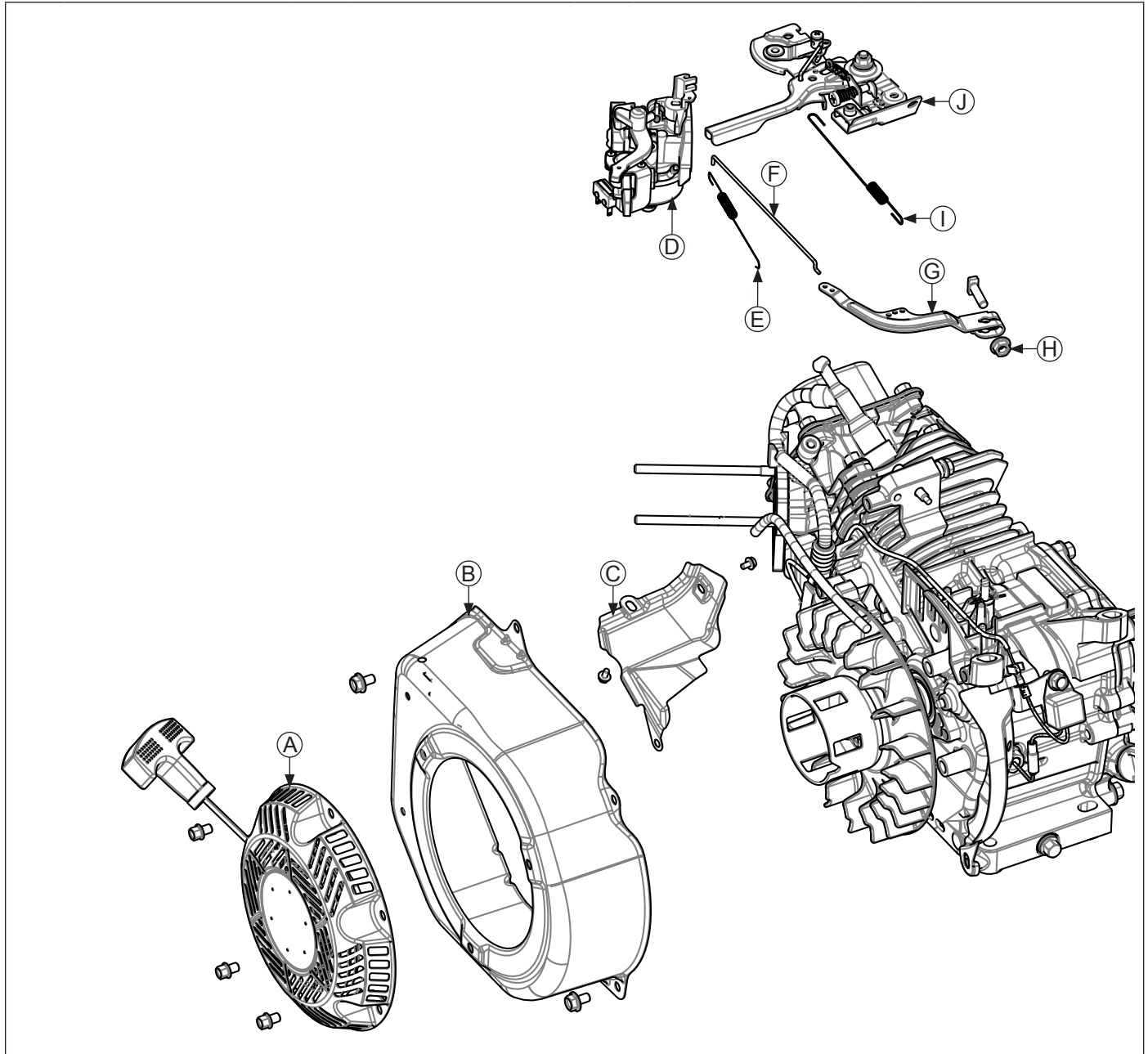

A	Retractable Starter	B	Blower Housing	C	Cylinder Head Shield	D	Carburetor
E	Linkage Spring	F	Throttle Linkage	G	Governor Lever	H	Hex Flange Nut
I	Governor Spring	J	Speed Control Assembly				

Reassembly

CH260/CH270 Blower Housing/Control Panel Components

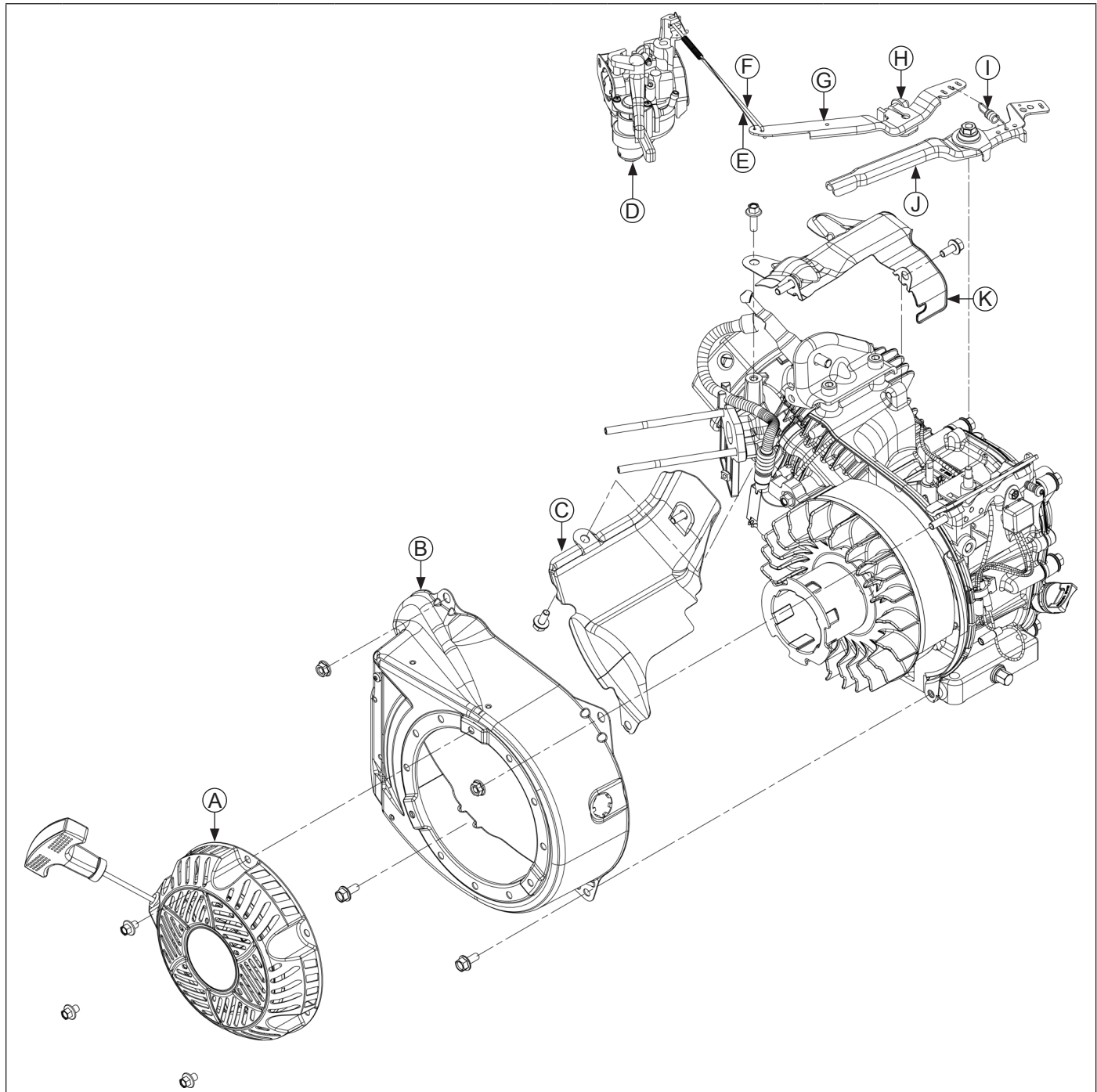

A	Retractable Starter	B	Blower Housing	C	Lower Shield	D	Carburetor
E	Dampening Spring	F	Throttle Linkage	G	Governor Lever	H	Hex Flange Nut
I	Governor Spring	J	Throttle Lever	K	Upper Shield		

CH395/CH440 Blower Housing/Control Panel Components

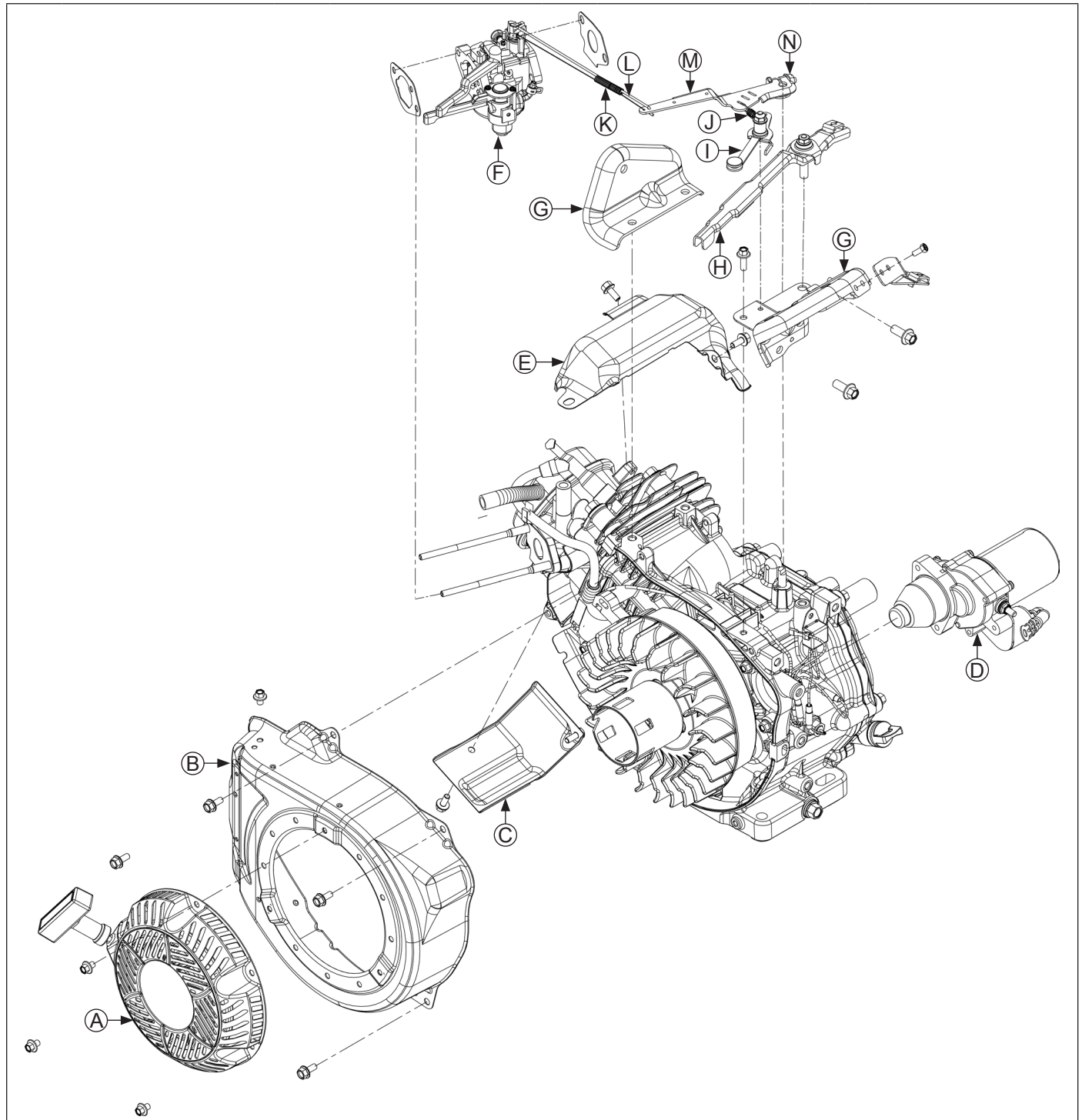

A	Retractable Starter	B	Blower Housing	C	Lower Shield	D	Electric Starter
E	Upper Shield	F	Carburetor	G	Fuel Tank Brackets	H	Throttle Lever
I	Pivot Lever	J	Governor Spring	K	Dampening Spring	L	Throttle Linkage
M	Governor Lever	N	Nut				

Reassembly

CH395/CH440 Electronic Governor Blower Housing/Control Panel Components

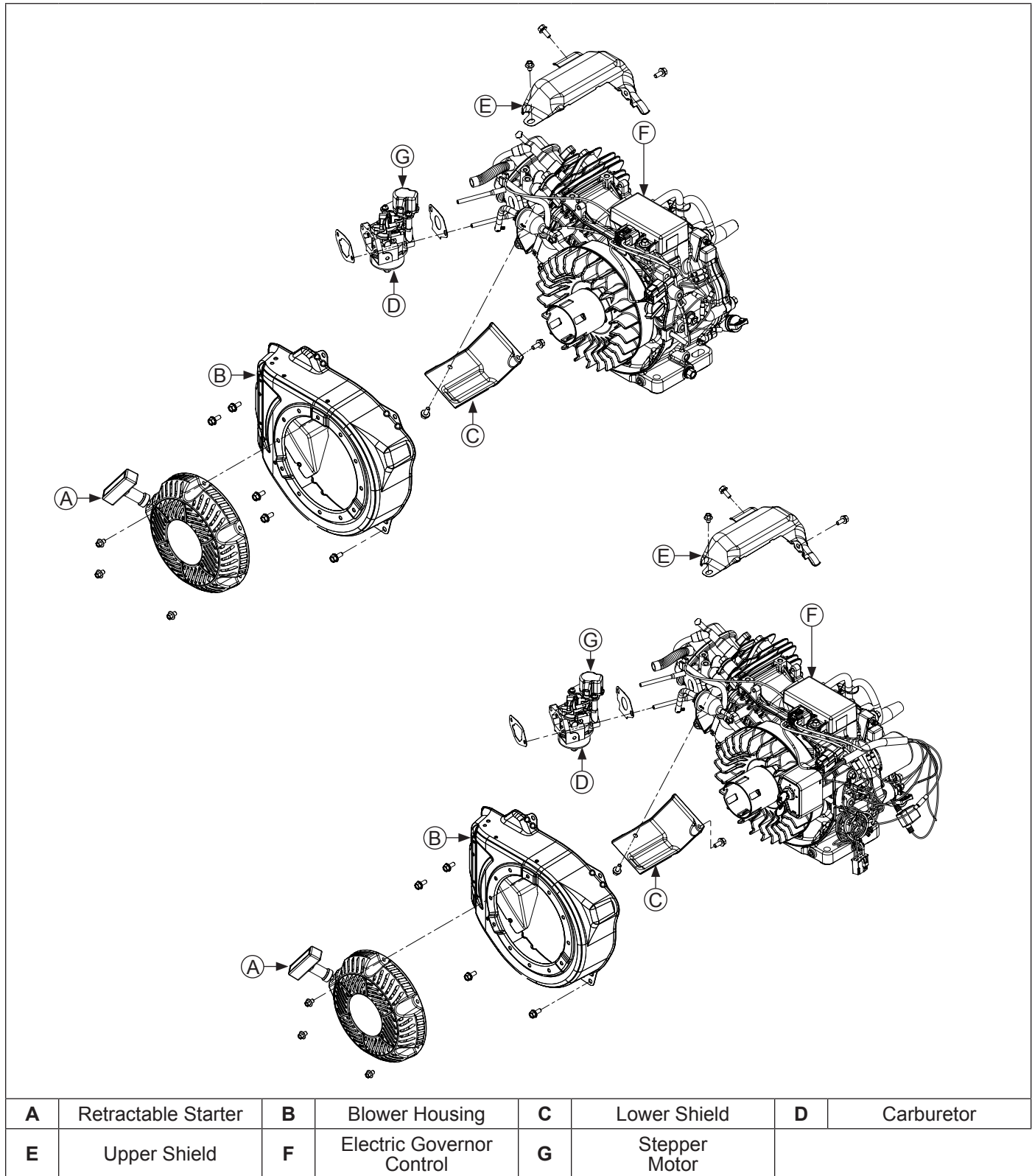

Install Fuel Tank Supports and Shut Down Switch with Bracket (if equipped)

CH260, CH270

1. Position both tank support brackets on crankcase and loosely install with screws.
2. Position shut down switch with bracket on tank bracket and install threaded stud to secure.
3. Torque tank support bracket hardware to 24 N·m (212 in. lb.).

CH395, CH440

NOTE: Threaded stud and bracket with shut down switch should not be removed.

Position both tank support brackets on crankcase and install with screws. Torque to 24 N·m (212 in. lb.).

Install Carburetor

1. Install a new insulator to cylinder head gasket onto carburetor studs, followed by insulator and carburetor to insulator gasket.
2. Push carburetor onto studs.
3. Connect throttle link and dampening spring into their respective holes in throttle lever.
4. If equipped with a fuel shut-off solenoid, connect both lead wire terminals to solenoid leads. Secure both solenoid wires with a new tie strap.
5. If equipped with ignition and fuel shut-off, carefully connect both wiring harness terminals to micro switch on carburetor.

Install Carburetor with Stepper Motor (Electronic Governor Only)

1. Install a new insulator to cylinder head gasket onto carburetor studs, followed by insulator and carburetor with stepper motor to insulator gasket.
2. Push carburetor onto studs.
3. Connect wiring harness to stepper motor.

Install Engine Shields and Air Cleaner Base

CH245, CH255

1. Install a new carburetor to air cleaner base gasket onto carburetor mounting studs followed by air cleaner base. Attach breather hose onto air cleaner base connection port. Connect opposite end of breather hose to valve cover.
2. Secure base with nuts on mounting studs. Torque to 8 N·m (71 in. lb.).
3. Secure base to blower housing with screws. Torque to 1.3 N·m (12 in. lb.).
4. Install cylinder head shield and secure with screws.

CH260, CH270

1. Install upper shield on cylinder, engaging tab hole on fuel tank bracket stud.
2. Install screw in rear of top air shield, but do not tighten at this time.
3. Install a new carburetor to air cleaner base gasket onto carburetor mounting studs followed by air cleaner base. Attach breather hose onto air cleaner base connection port. Connect opposite end of breather hose to valve cover.
4. Secure base with nuts on mounting studs and screw through top heat shield into crankcase housing. Torque hardware to 8 N·m (71 in. lb.).
5. Install lower heat shield and secure with screws.

CH395, CH440

NOTE: When securing low-profile air cleaner, screw is installed through base into blower housing. Torque to 6.7 N·m (59 in. lb.).

1. Install upper shield on cylinder and secure with screws. Torque to 8 N·m (71 in. lb.).
2. Install lower shield on cylinder and secure with screws. Torque to 8 N·m (71 in. lb.).
3. Install a new carburetor to air cleaner base gasket onto carburetor mounting studs followed by air cleaner base. Attach breather hose onto air cleaner base connection port. Connect opposite end of breather hose to valve cover.
4. Secure base with nuts on mounting studs and screw into crankcase housing. Torque hardware to 8 N·m (71 in. lb.).

Reassembly

Install Electric Starter and Control Panel (if equipped)

1. Align and mount electric starter onto crankcase. Install and torque screws to 24 N·m (212 in. lb.).
2. Connect electrical leads for Oil Sentry™, ignition module, key switch, relay, and starter.
3. Mount control panel to crankcase and secure with screws. Ensure ground wires are placed between screw and bracket. Torque screws to 24 N·m (212 in. lb.).

Install Electronic Governor Control (Electronic Governor Only)

1. Place governor control in position on crankcase and secure with two screws. Torque screws to 24 N·m (212 in. lb.).
2. Install wires to control panel.
3. Install wiring harness to electronic governor control.

Install Blower Housing

1. Position spark plug lead in molded clip in carburetor insulator.
2. CH245, CH255: Install blower housing on crankcase with screws. Torque screws to 10 N·m (89 in. lb.).
CH260, CH270: Install blower housing on crankcase with nuts and screws. Torque nuts to 8 N·m (71 in. lb.) and screws to 10 N·m (89 in. lb.).
CH395, CH440: Install blower housing on crankcase with screws. Torque screws to 10 N·m (89 in. lb.).

Install Retractable Starter

1. Install retractable starter on blower housing using screws. Finger tighten mounting screws only.
2. Pull rope handle to engage pawls and center starter to drive cup. Hold in this position and torque mounting screws to 5.4 N·m (48 in. lb.).

Install Throttle Link, Governor Lever, Governor Spring, and Throttle Lever (Mechanical Governor Only)

1. Connect throttle linkage and dampening spring to arm of governor lever.
2. Install governor lever onto shaft. Assemble screw and locknut, but do not tighten.
3. CH245, CH255, CH260, CH270: Push governor lever in direction indicated and hold against stop. Turn governor shaft clockwise until it stops. Tighten nut on governor lever clamp bolt to lock lever on shaft. Torque nut to 12 N·m (106 in. lb.).
CH395, CH440: Push governor lever in direction indicated and hold in this position. Turn governor shaft counterclockwise until it stops. Tighten nut on governor lever clamp bolt to lock lever on shaft. Torque nut to 12 N·m (106 in. lb.).
4. Install spring on governor and throttle levers in holes previously marked in disassembly.
5. CH260-CH440: Install throttle lever and a fender washer on threaded stud of fuel tank bracket. Install a nylon washer, wave spring, and tabbed washer (with tab engaged in slot) on stud above throttle lever and secure with nut. Torque nut to 9 N·m (80 in. lb.).
5. CH245/CH255: Install fuel tank before installing speed control assembly.

Install Fuel Tank CH245/CH255 (if equipped)

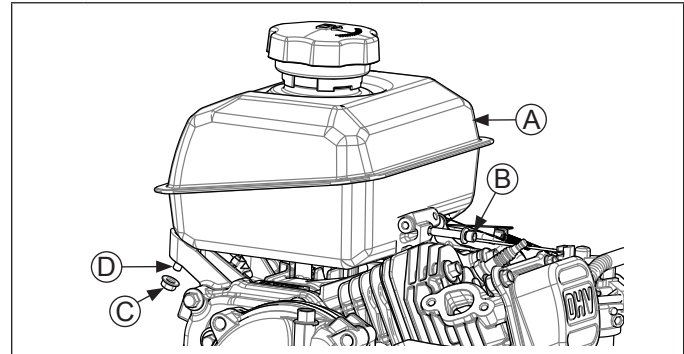

A	Fuel Tank	B	Screw
C	Nut	D	Fuel Tank Stud

1. Route fuel line across top of engine toward carburetor while positioning fuel tank on top of crankcase.
2. Secure with screw on inner mounting area.
3. Install nuts on fuel tank studs.
4. Torque fuel tank screw and nuts to 10 N·m (89 in. lb.).
5. Position fuel line in clip on blower housing. Connect fuel line to carburetor and secure with clamp.

CH245/CH255 Speed Control Assembly

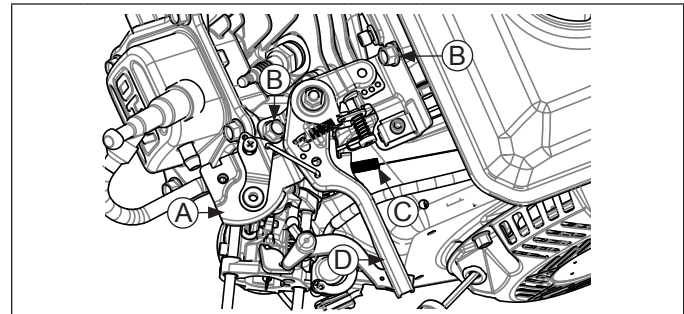

A	Speed Control Assembly	B	Screw
C	Governor Spring	D	Throttle Control Lever

- Position speed control assembly on crankcase and secure with screws. Torque to 10 N·m (89 in. lb.).

CH245/CH255 Governor Lever Hole Position/RPM Chart

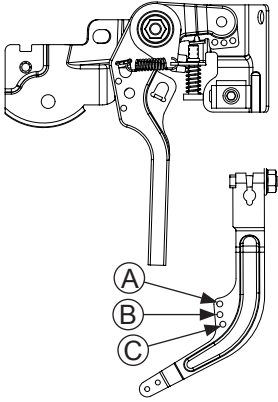

Engine Speed RPM	8-13% Droop	
	Spring Color	Hole
3801-4000	Black	B

CH260/CH270 Governor Lever Hole Position/RPM Chart

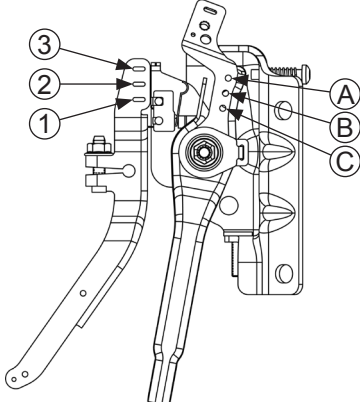

Engine Speed RPM	5-8% Droop		5-10% Droop		8-12% Droop	
	Spring Color	Hole Combination	Spring Color	Hole Combination	Spring Color	Hole Combination
2800-3000					Yellow	#1-B
3001-3200	Green	#3-C	Black	#3-C	Yellow	#1-A
3201-3400					Yellow	#2-A
3401-3600					Red	#2-A
3601-3800	Yellow	#2-A			White	#3-A
3601-3800	Black	#3-A				
3801-4000					Red	#3-A

Reassembly

CH395 Governor Lever Hole Position/RPM Chart

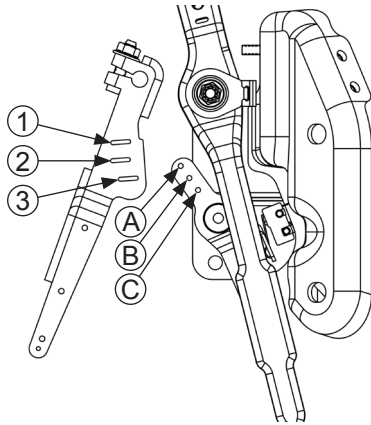

Engine Speed RPM	3-8% Droop		6-10% Droop		7-12% Droop	
	Spring Color	Hole Combination	Spring Color	Hole Combination	Spring Color	Hole Combination
2800-3000					Yellow	#1-B
3001-3200			Black	#1-B	Yellow	#1-B
3201-3400					Yellow	#1-B
3401-3600					Yellow	#2-B
3601-3800	Purple	#1-A	Red	#1-B	Yellow	#2-B
3801-4000					Yellow	#2-B

CH440 Governor Lever Hole Position/RPM Chart

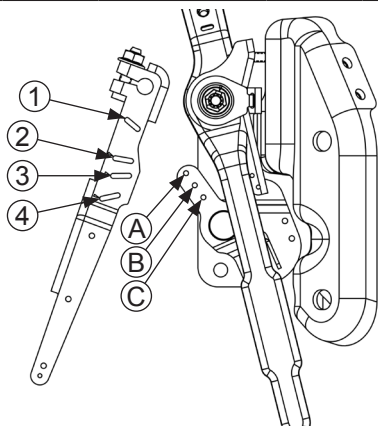

Engine Speed RPM	6-12% Droop		3-6% Droop	
	Spring Color	Hole Combination	Spring Color	Hole Combination
3801-4000	None	#2-B		
3601-3800	None	#2-B	White	#2-A
3401-3600	None	#2-B		
3201-3400	White	#3-A		
3001-3200	White	#3-A	Green	#1-B
2801-3001	White	#3-A		

External Engine Components

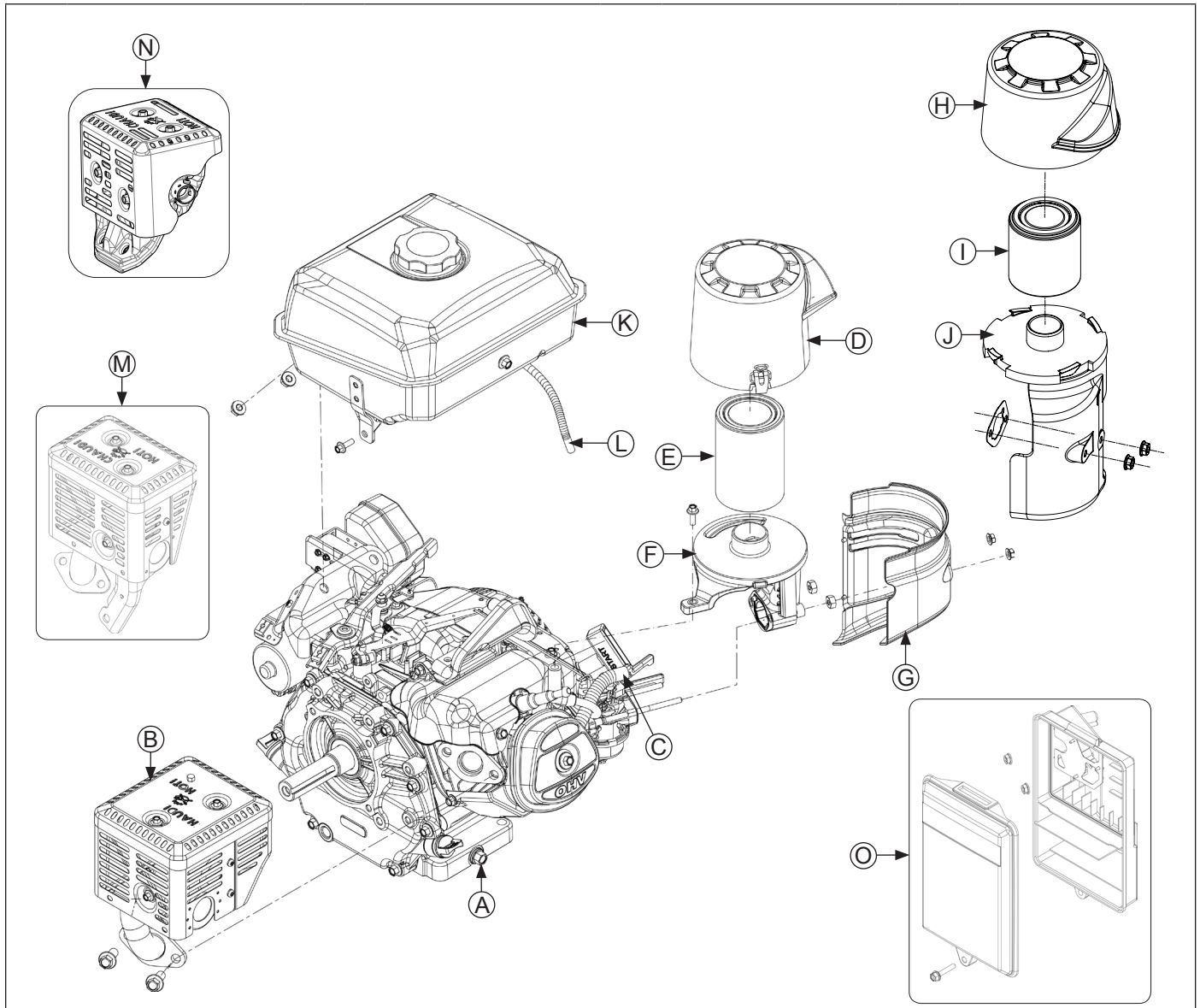

A	Oil Drain Plug	B	CH395, CH440 Muffler Assembly	C	Breather Hose	D	CH260-CH440 Quad-Clean™ Cover
E	CH260-CH440 Quad-Clean™ Element/Precleaner	F	CH260-CH440 Quad-Clean™ Base	G	CH260-CH440 Carburetor Shroud	H	CH245-CH255 Quad-Clean™ Cover
I	CH245-CH255 Quad-Clean™ Element/Precleaner	J	CH245-CH255 Quad-Clean™ Base	K	Fuel Tank	L	Fuel Line
M	CH260, CH270 Muffler Assembly	N	CH245, CH255 Muffler Assembly	O	Low-Profile Air Cleaner		

Reassembly

Install Oil Sentry™ Module

NOTE: If Oil Sentry™ module is mounted inside control panel, skip this step.

1. Install Oil Sentry™ module and secure with screw. Torque screw to 3.5 N·m (31 in. lb.).
2. Connect electrical leads for Oil Sentry™ module.

Install Fuel Tank CH260-CH440 (if equipped)

1. Position fuel tank on mounting brackets. Secure with screws on inner mounting bracket and on PTO side strap.
2. Install nuts on fuel tank studs.
3. Torque side strap screw to 10 N·m (89 in. lb.).
4. Torque remaining screw and nuts to 24 N·m (212 in. lb.).
5. Position fuel line in clip on bottom of tank. Connect fuel line to shut-off valve on carburetor and secure with clamp.

Install Carburetor Shroud (if equipped)

Install carburetor shroud onto studs, over carburetor. Secure with nuts and screws. Torque nuts to 4 N·m (35 in. lb.) and screws to 1.3 N·m (12 in. lb.).

Install Muffler and Heat Shield Assembly

1. Install a new exhaust gasket onto exhaust studs.
2. Position muffler and heat shield assembly and install screw in support bracket and screws in exhaust outlet flange.
3. Torque screws to:
CH245-CH270 24 N·m (212 in. lb.)
CH395, CH440 35 N·m (310 in. lb.)

Install Exhaust Deflector (if equipped)

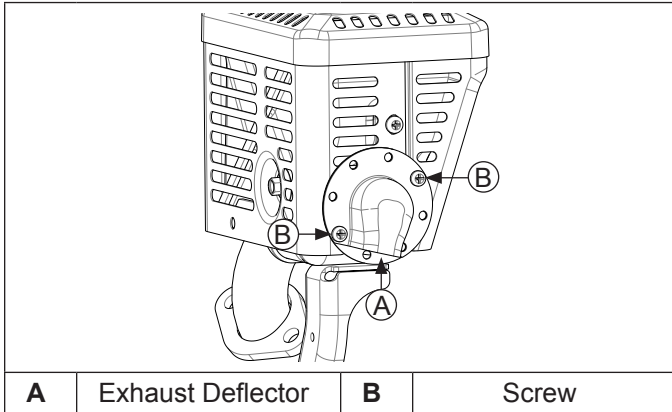

Position exhaust deflector on muffler as noted in Disassembly and secure with screws. Torque screws to 1.5 N·m (13 in. lb.)

Install Pipe Protector Shield (if equipped)

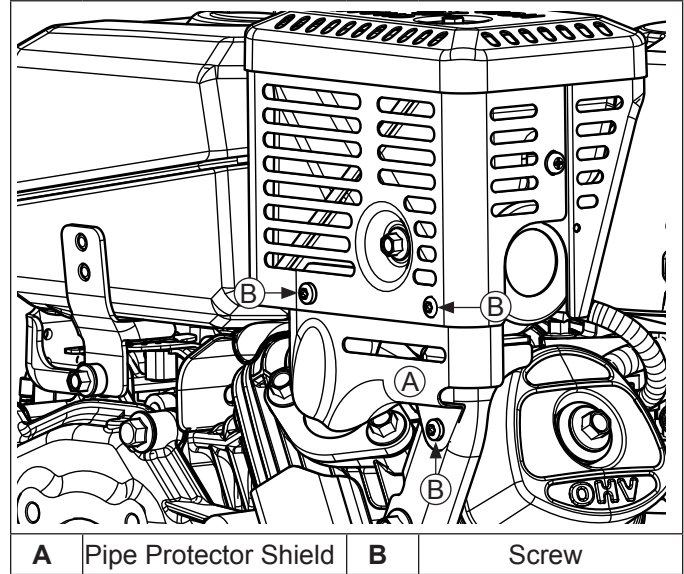

Position pipe protector shield on muffler and secure with screws. Torque screws to 2.5 N·m (22 in. lb.)

Install Air Cleaner Element and Cover

Install Quad-Clean™ Air Cleaner

1. Place air cleaner element with precleaner onto boss on air cleaner base.
2. Position air cleaner cover for normal operation (sun decal out) or cold weather operation (snowflake decal out).
3. CH245/CH255: Turn air cleaner cover (clockwise) to secure tabs inside cover in base.
CH260-CH440: Place latches under tabs on base; lift up bails to secure cover.

Install Low-Profile Air Cleaner

1. Place foam element in air cleaner base.
2. Position air cleaner cover onto base and secure with screw.

Install Oil Bath Air Cleaner

Refer to Air Cleaner/Intake.

Prepare Engine for Operation

Engine is now reassembled. Before starting or operating engine be sure to do following:

1. Make sure all hardware is properly torqued.
2. Make sure oil drain plugs, oil fill plugs and Oil Sentry_{TM} wire lead bushing are tightened securely.
3. Fill crankcase with correct oil. Refer to Maintenance and Lubrication System for oil recommendations and procedures.

Testing Engine

It is recommended engine be operated on a test stand or bench prior to installation on a piece of equipment.

1. Set engine up on a test stand. Check gas and oil levels. Start engine and run for 5-10 minutes between idle and midrange. Adjust carburetor settings as required. Low idle speed should be set to 1800 RPM (± 150) or application specifications.
2. Maximum no load high idle engine speed is 3750 RPM.

Adjust high idle speed adjusting stop screw as necessary.



1P17 690 01



6 50531 96539 4