

Command Pro EFI

EZT715-EZT750

Service Manual

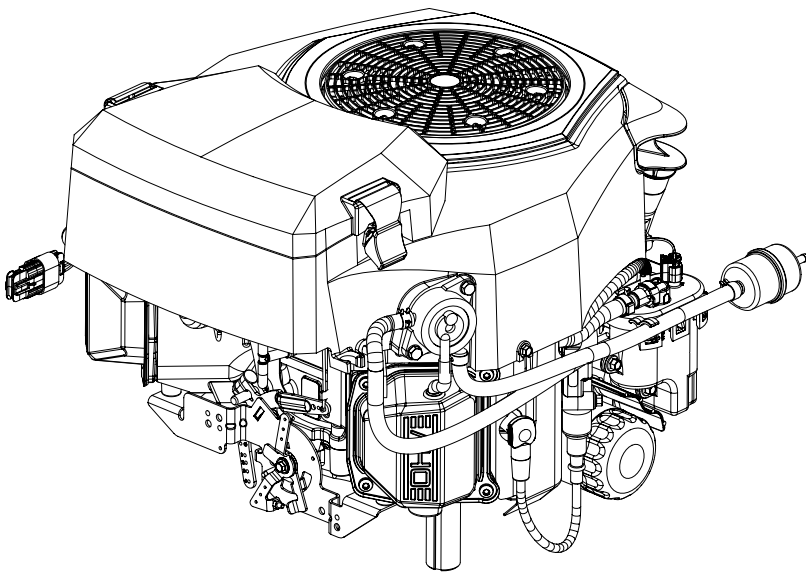

Kohler Engines
is now Rehlko.



2	Safety
3	Maintenance
5	Specifications
23	Tools and Aids
26	Troubleshooting
30	Air Cleaner/Intake
31	Electronic Fuel Injection (EFI) System
55	Governor System
56	Lubrication System
58	Electrical System
64	Starter System
68	Emission Compliant Systems
69	Disassembly/Inspection and Service
86	Reassembly

IMPORTANT: Read all safety precautions and instructions carefully before operating equipment. Refer to operating instruction of equipment that this engine powers.

Ensure engine is stopped and level before performing any maintenance or service.

Safety

SAFETY PRECAUTIONS

▲ WARNING: A hazard that could result in death, serious injury, or substantial property damage.

▲ CAUTION: A hazard that could result in minor personal injury or property damage.

NOTE: is used to notify people of important installation, operation, or maintenance information.

	▲ WARNING
	Explosive Fuel can cause fires and severe burns. Do not fill fuel tank while engine is hot or running.
Gasoline is extremely flammable and its vapors can explode if ignited. Store gasoline only in approved containers, in well ventilated, unoccupied buildings, away from sparks or flames. Spilled fuel could ignite if it comes in contact with hot parts or sparks from ignition. Never use gasoline as a cleaning agent.	

	▲ WARNING
	Rotating Parts can cause severe injury. Stay away while engine is in operation.
Keep hands, feet, hair, and clothing away from all moving parts to prevent injury. Never operate engine with covers, shrouds, or guards removed.	

	▲ WARNING
	Carbon Monoxide can cause severe nausea, fainting or death. Avoid inhaling exhaust fumes. Never run engine indoors or in enclosed spaces.
Engine exhaust gases contain poisonous carbon monoxide. Carbon monoxide is odorless, colorless, and can cause death if inhaled.	

	▲ WARNING
	Accidental Starts can cause severe injury or death. Disconnect and ground spark plug lead(s) before servicing.
Before working on engine or equipment, disable engine as follows: 1) Disconnect spark plug lead(s). 2) Disconnect negative (-) battery cable from battery.	

	▲ WARNING
	Hot Parts can cause severe burns. Do not touch engine while operating or just after stopping.
Never operate engine with heat shields or guards removed.	

	▲ WARNING
	Cleaning Solvents can cause severe injury or death. Use only in well ventilated areas away from ignition sources.
Carburetor cleaners and solvents are extremely flammable. Follow cleaner manufacturer's warnings and instructions on its proper and safe use. Never use gasoline as a cleaning agent.	

	▲ CAUTION
	Electrical Shock can cause injury. Do not touch wires while engine is running.

	▲ CAUTION
	Damaging Crankshaft and Flywheel can cause personal injury.
Using improper procedures can lead to broken fragments. Broken fragments could be thrown from engine. Always observe and use precautions and procedures when installing flywheel.	

	▲ CAUTION
	Failure to utilize or reassemble debris screen as designed could result in debris screen failure and serious personal injury.

	▲ WARNING
	High Pressure Fluids can puncture skin and cause severe injury or death. Do not work on fuel system without proper training or safety equipment.
Fluid puncture injuries are highly toxic and hazardous. If an injury occurs, seek immediate medical attention.	

	▲ WARNING
	Explosive Fuel can cause fires and severe burns. Fuel system ALWAYS remains under HIGH PRESSURE.
Wrap a shop towel completely around fuel pump module connector. Press release button(s) and slowly pull connector away from fuel pump module allowing shop towel to absorb any residual fuel in high pressure fuel line. Any spilled fuel must be completely wiped up immediately.	

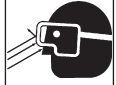
	▲ WARNING
	Uncoiling Spring can cause severe injury. Wear safety goggles or face protection when servicing retractable starter.
Retractable starters contain a powerful, recoil spring that is under tension. Always wear safety goggles when servicing retractable starters and carefully follow instructions in Retractable Starter for relieving spring tension.	

MAINTENANCE INSTRUCTIONS

	▲ WARNING	
	<p>Accidental Starts can cause severe injury or death.</p> <p>Disconnect and ground spark plug lead(s) before servicing.</p>	<p>Before working on engine or equipment, disable engine as follows: 1) Disconnect spark plug lead(s). 2) Disconnect negative (-) battery cable from battery.</p>

Normal maintenance, replacement or repair of emission control devices and systems may be performed by any repair establishment or individual; however, warranty repairs must be performed by a Rehlko authorized dealer.

MAINTENANCE SCHEDULE

Every 25 Hours¹

• Service/replace precleaner.	Air Cleaner/Intake
• Replace air cleaner element (if not equipped with precleaner).	Air Cleaner/Intake

Every 100 Hours¹

• Replace air cleaner element (if equipped with precleaner).	Air Cleaner/Intake
• Change oil and filter.	Lubrication System
• Remove cooling shrouds and clean cooling areas.	Air Cleaner/Intake

Every 100 Hours

• Check that all fasteners are in place and components are properly secured.	Reassembly
--	------------

Every 200 Hours¹

• Replace unique EFI fuel filter.	
-----------------------------------	--

Every 300 Hours³

• Change oil and filter (Xtended Life PRO 10W-50 oil and Xtended Life PRO 10W-50 filter only).	Lubrication System
--	--------------------

Every 500 Hours²

• Have valve lash checked/adjusted.	Reassembly
-------------------------------------	------------

Every 500 Hours

• Replace spark plugs and set gap.	Electrical System
------------------------------------	-------------------

¹ Perform these procedures more frequently under severe, dusty, dirty conditions.

² Have a Rehlko authorized dealer perform this service.

³ Option only if using Xtended Life PRO 10W-50 oil and PRO filter.

REPAIRS/SERVICE PARTS

Rehlko genuine service parts can be purchased from Rehlko authorized dealers. To find a local Rehlko authorized dealer visit Engines.rehlko.com or call 1-800-544-2444 (U.S. and Canada).

Maintenance

OIL RECOMMENDATIONS

All-season Xtended Life PRO 10W-50 Synthetic Oil is the ideal oil for Rehlko engines. It is specifically formulated to extend the oil and oil filter change interval to 300 Hours when paired with a Xtended Life PRO 10W-50 Extended Life Oil Filter.

300-Hour oil and oil filter change intervals are exclusive to and only authorized on Rehlko engines that utilize both the Xtended Life PRO 10W-50 Synthetic Oil and Xtended Life PRO 10W-50 Extended Life Oil Filter. Alternative engine oils and oil filters may be used with Rehlko engines but require 100-Hour oil and oil filter change intervals for proper maintenance. Oil must be API (American Petroleum Institute) service class SJ or higher. Select viscosity based on air temperature at time of operation as shown below.

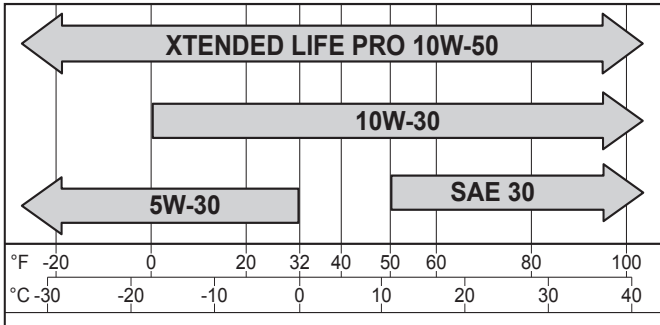

FUEL RECOMMENDATIONS



▲ WARNING

Explosive Fuel can cause fires and severe burns.

Do not fill fuel tank while engine is hot or running.

Gasoline is extremely flammable and its vapors can explode if ignited. Store gasoline only in approved containers, in well ventilated, unoccupied buildings, away from sparks or flames. Spilled fuel could ignite if it comes in contact with hot parts or sparks from ignition. Never use gasoline as a cleaning agent.

NOTE: E15, E20 and E85 are NOT approved and should NOT be used; effects of old, stale or contaminated fuel are not warrantable.

Fuel must meet these requirements:

- Clean, fresh, unleaded gasoline.
- Octane rating of 87 (R+M)/2 or higher.
- Research Octane Number (RON) 90 octane minimum.
- Gasoline up to 10% ethyl alcohol, 90% unleaded is acceptable.
- Methyl Tertiary Butyl Ether (MTBE) and unleaded gasoline blend (max 15% MTBE by volume) are approved.
- Do not add oil to gasoline.
- Do not overfill fuel tank.
- Do not use gasoline older than 30 days.

STORAGE

If engine will be out of service for 2 months or more follow procedure below.

1. Add Xtended Life PRO 10W-50 Series fuel treatment or equivalent to fuel tank. Run engine 2-3 minutes to get stabilized fuel into fuel system (failures due to untreated fuel are not warrantable).
2. Change oil while engine is still warm from operation (NOT required if using Xtended Life PRO 10W-50 full-synthetic oil). Remove spark plug(s) and pour about 1 oz. of engine oil into cylinder(s). Replace spark plug(s) and crank engine slowly to distribute oil.
3. Disconnect negative (-) battery cable.
4. Store engine in a clean, dry place.

Engine Dimensions-with Heavy-Duty Air Cleaner-Flywheel Side

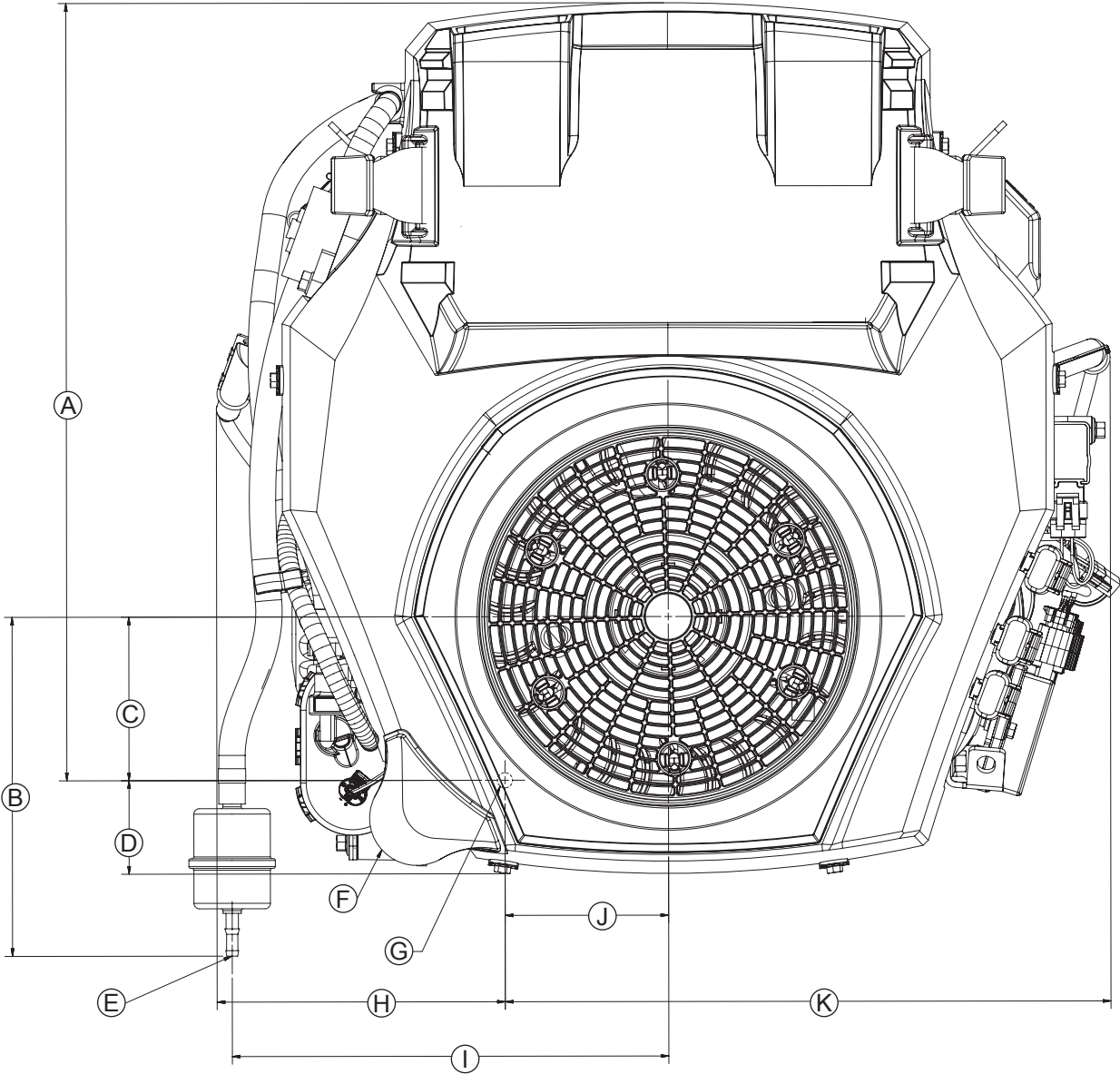

A	426.9 mm (16.81 in.)	B	186.2 mm (7.33 in.)	C	89.8 mm (3.54 in.)	D	51.3 mm (2.02 in.)
E	Fuel Line Connection Point	F	Oil Fill and Dipstick (Yellow)	G	Mounting Hole "A"	H	158.3 mm (6.23 in.)
I	239.8 mm (9.44 in.)	J	89.8 mm (3.54 in.)	K	332.7 mm (13.10 in.)		

Specifications

Engine Dimensions-with Heavy-Duty Air Cleaner-Oil Filter Side

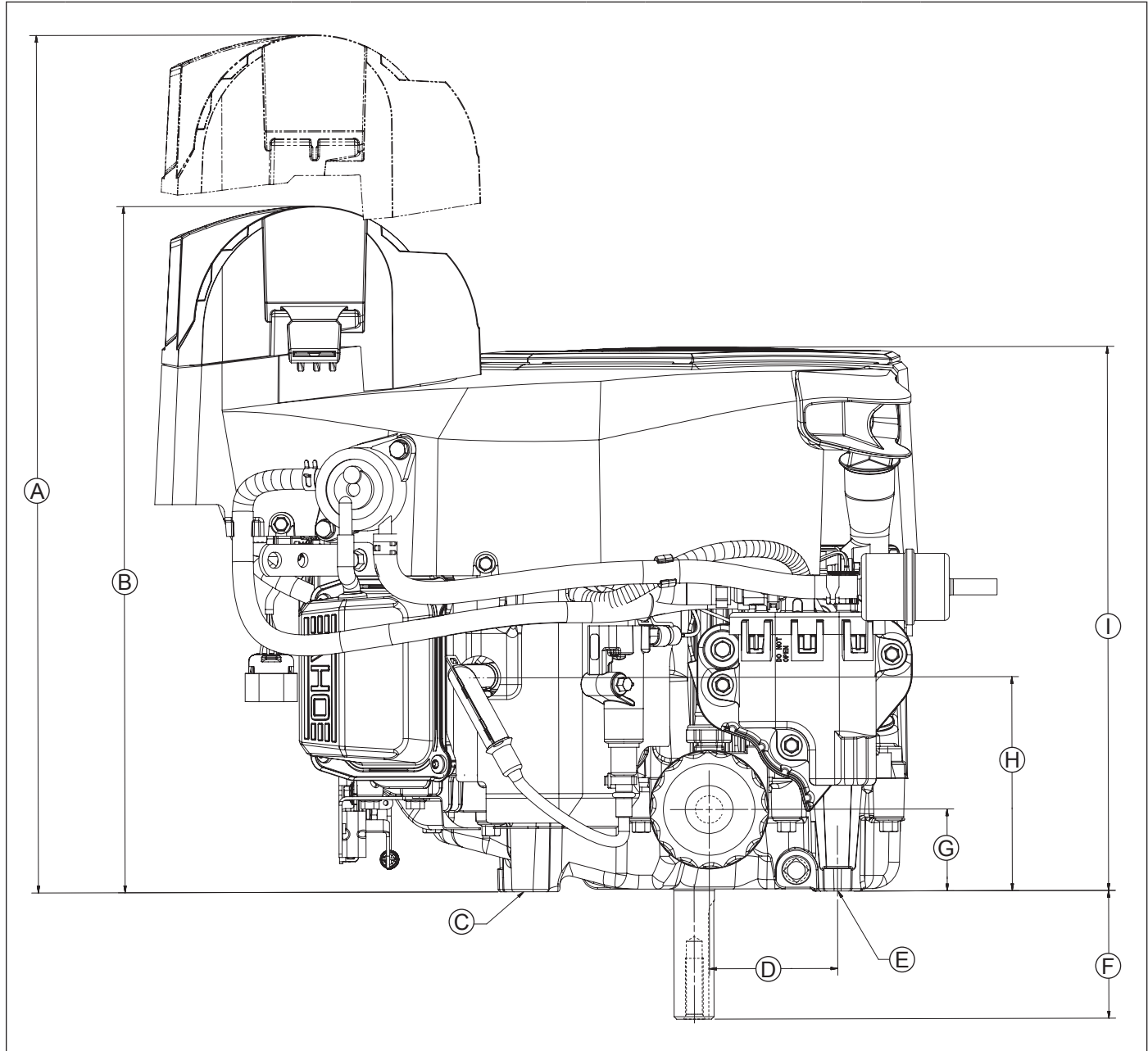

A	536.9 mm (21.14 in.) Air Cleaner Removal	B	429.6 mm (16.92 in.) Top of Air Cleaner	C	Engine Mounting Surface	D	80.3 mm (3.16 in.) Oil Filter
E	Mounting Hole "A"	F	80.0 mm (3.15 in.)	G	51.2 mm (2.02 in.) Oil Filter	H	134.0 mm (5.28 in.) Spark Plug Center Line
I	340.7 mm (13.41 in.)						

Engine Dimensions-with Heavy-Duty Air Cleaner-Engine Mounting Surface (PTO End)

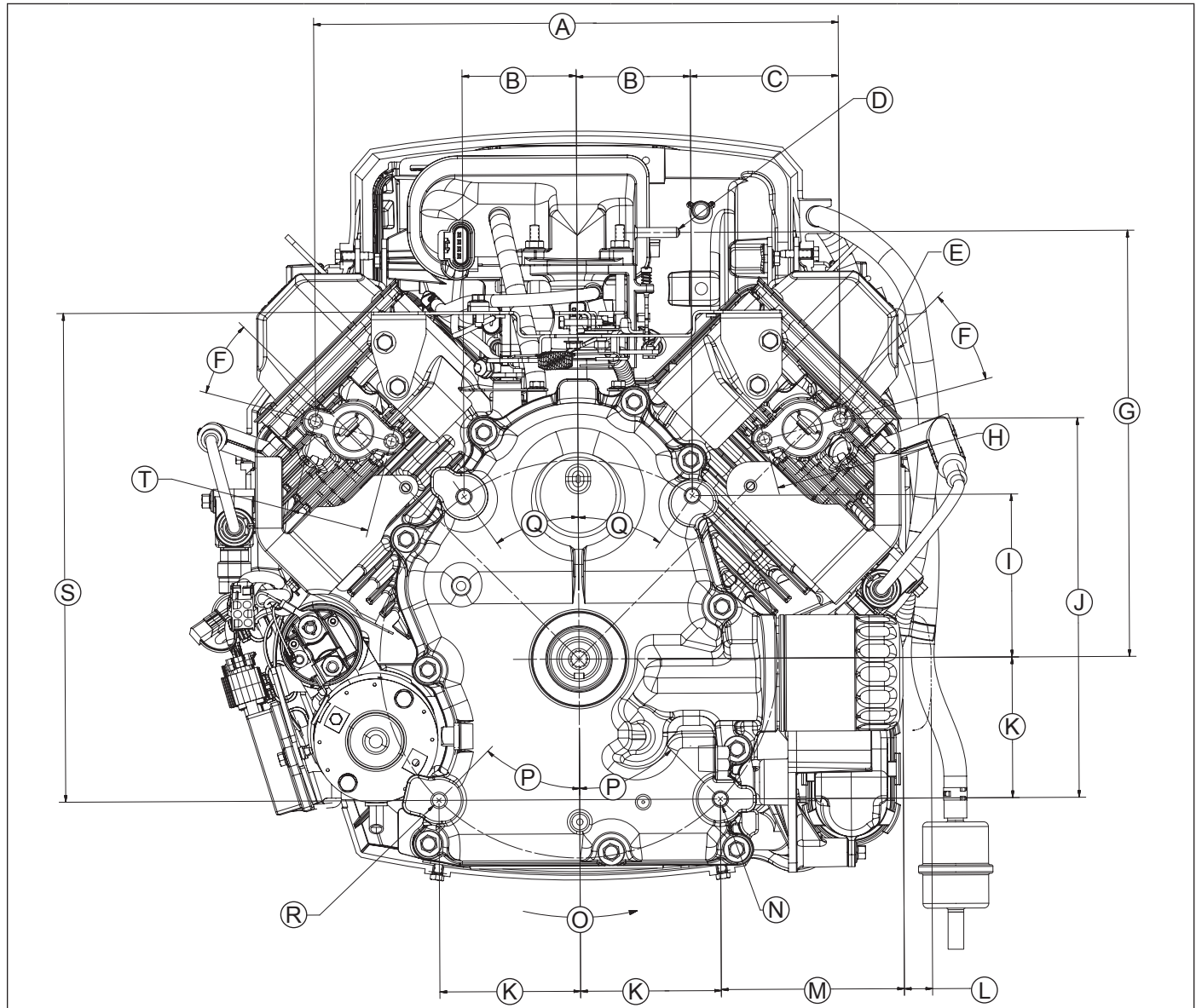

A	334.8 mm (13.18 in.)	B	72.8 mm (2.87 in.)	C	94.5 mm (3.72 in.)	D	Evap Connection Point
E	4 X 5/16-18 UNC-2B in. 16.5 mm (0.649 in.) Deep No Studs	F	30°	G	272.1 mm (10.71 in.)	H	50 mm (1.97 in.) Exhaust Port #2
I	104 mm (4.10 in.)	J	242.3 mm (9.54 in.)	K	89.8 mm (3.54 in.)	L	18 mm (0.71 in.) Oil Filter Removal
M	116.8 mm (4.60 in.)	N	Mounting Hole "A"	O	Rotation Direction	P	45°
Q	35°	R	4 X 9.005 mm (0.355 in.) 37 mm (1.46 in.) Deep on a Ø 254 mm (10.0 in.) B.C.	S	312.0 mm (12.28 in.) Throttle and Choke Cable Mounting Surface	T	50 mm (1.97 in.) Exhaust Port #1

Specifications

Engine Dimensions-with Heavy-Duty Air Cleaner-Starter Side

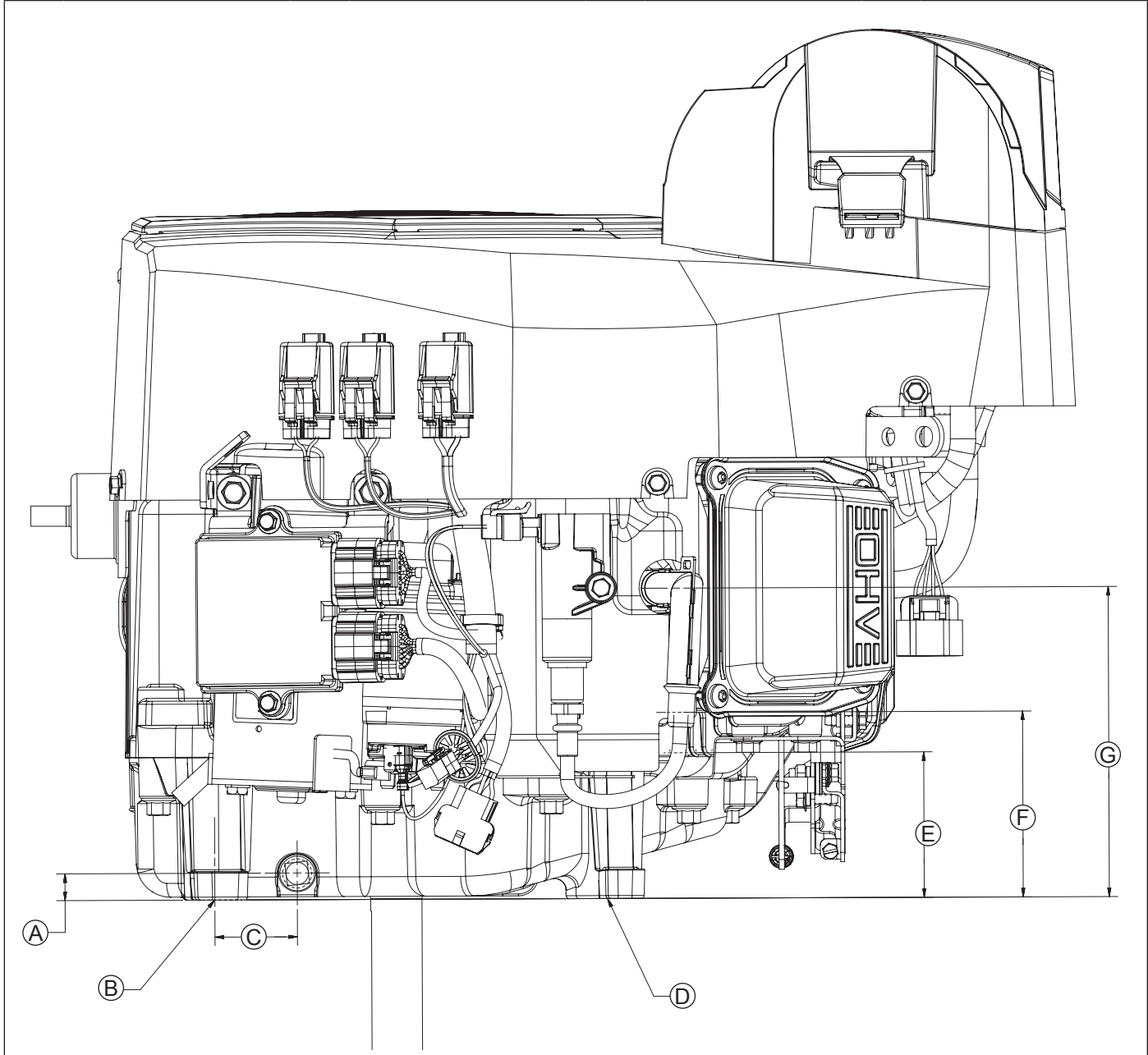

A	13.2 mm (0.52 in.)	B	Mounting Hole "A"	C	40.8 mm (1.61 in.)	D	Engine Mounting Surface
E	72.0 mm (2.83 in.) Exhaust Port #2	F	92.0 mm (3.62 in.) Exhaust Port #1	G	153.5 mm (6.04 in.) Spark Plug Center Line		

Engine Dimensions-with Heavy-Duty Air Cleaner-Valve Cover Side

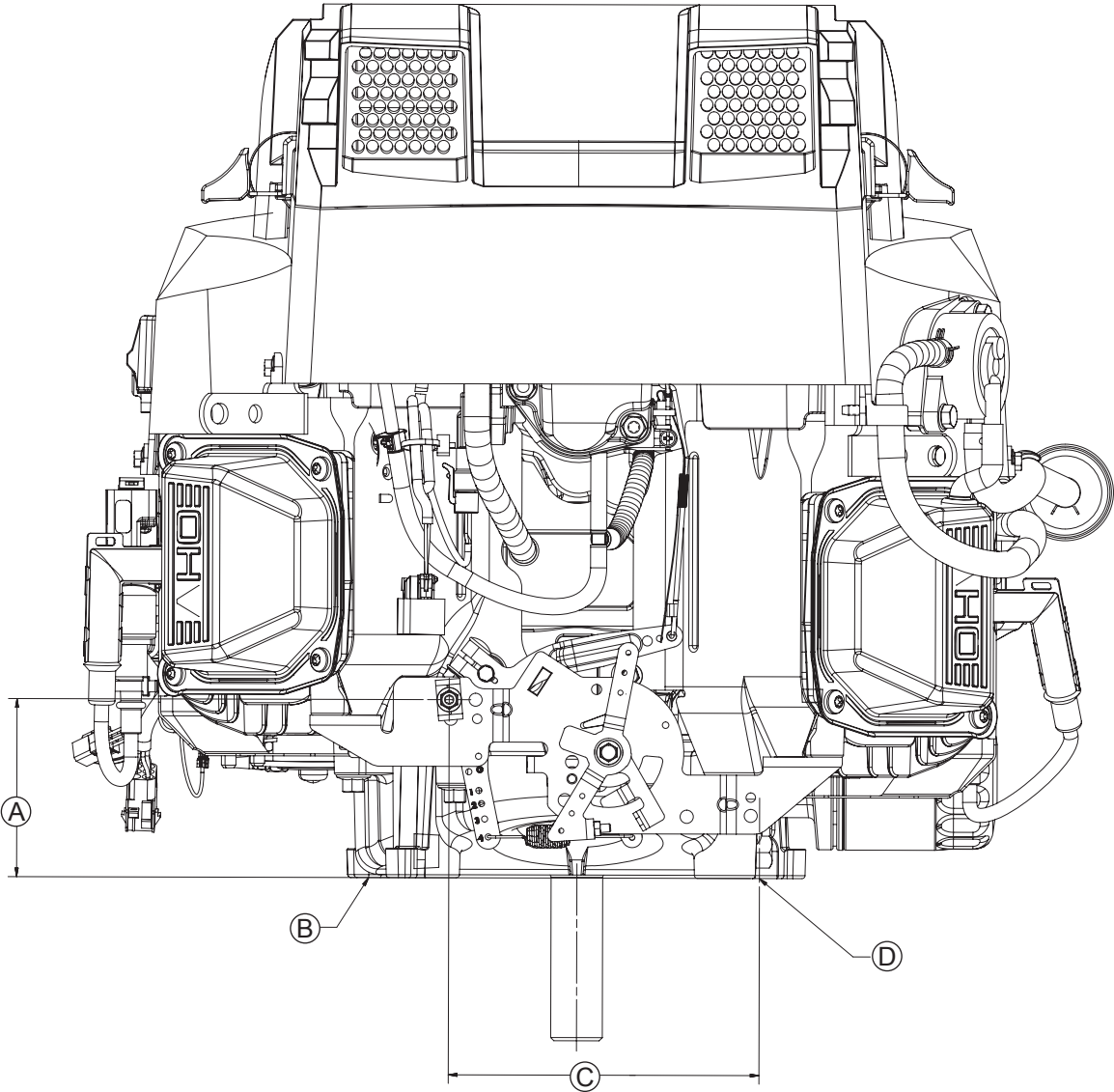

A	87.6 mm (3.45 in.)	B	Engine Mounting Surface	C	152.9 mm (6.02 in.)	D	Mounting Hole "A"
----------	--------------------	----------	-------------------------	----------	---------------------	----------	-------------------

Specifications

Engine Dimensions-with Low Profile Air Cleaner-Flywheel Side

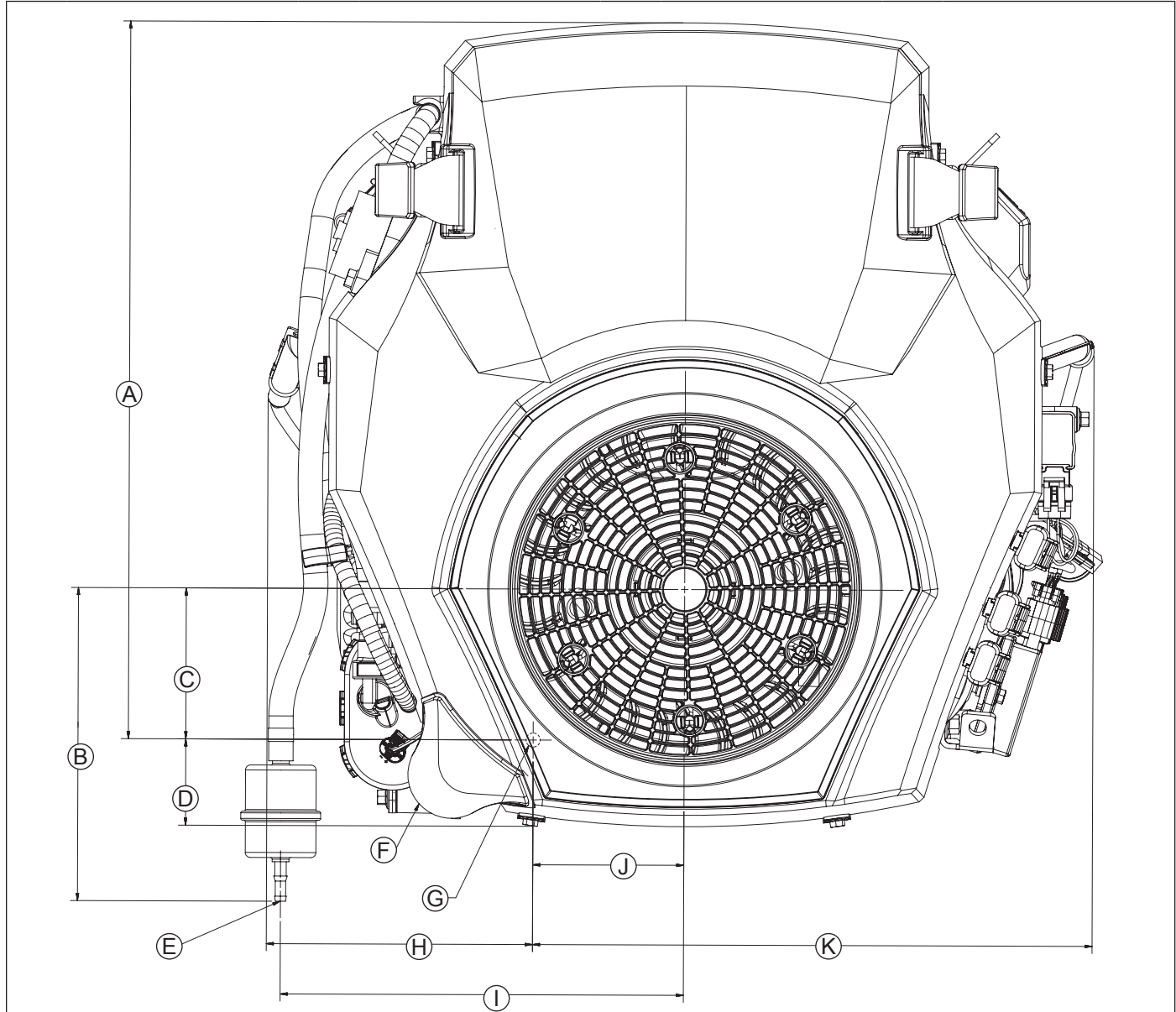

A	426.9 mm (16.81 in.)	B	186.2 mm (7.33 in.)	C	89.8 mm (3.54 in.)	D	51.3 mm (2.02 in.)
E	Fuel Line Connection Point	F	Oil Fill and Dipstick (Yellow)	G	Mounting Hole "A"	H	158.3 mm (6.23 in.)
I	239.8 mm (9.44 in.)	J	89.8 mm (3.54 in.)	K	332.7 mm (13.10 in.)		

Engine Dimensions-with Low Profile Air Cleaner-Oil Filter Side

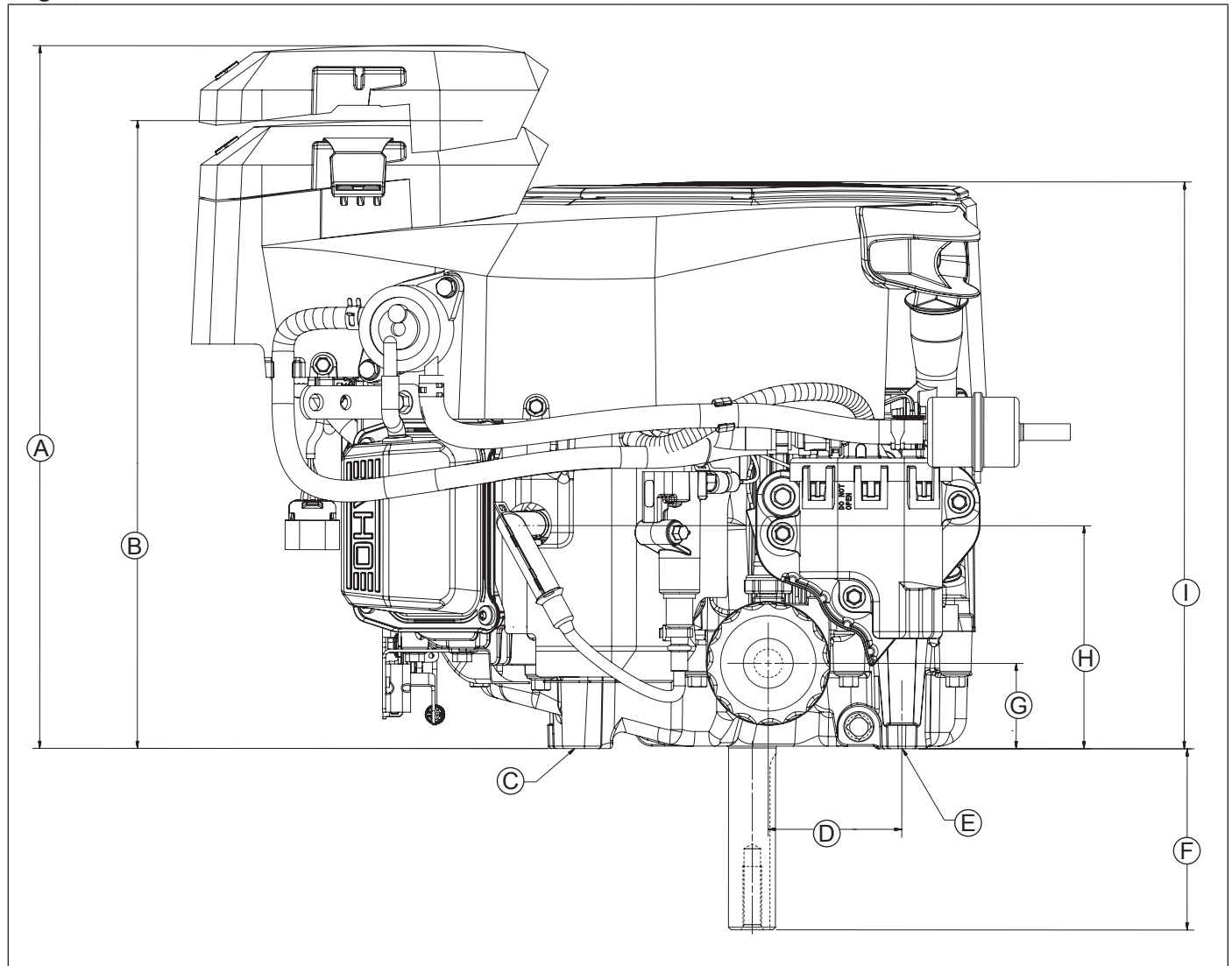

A	422.3 mm (16.63 in.) Air Cleaner Removal	B	377.3 mm (14.85 in.) Top of Air Cleaner	C	Engine Mounting Surface	D	80.3 mm (3.16 in.) Oil Filter
E	Mounting Hole "A"	F	108.9 mm (4.29 in.)	G	51.2 mm (2.02 in.) Oil Filter	H	134.0 mm (5.28 in.) Spark Plug Center Line
I	340.7 mm (13.41 in.)						

Specifications

Engine Dimensions-with Low Profile Air Cleaner-Engine Mounting Surface (PTO End)

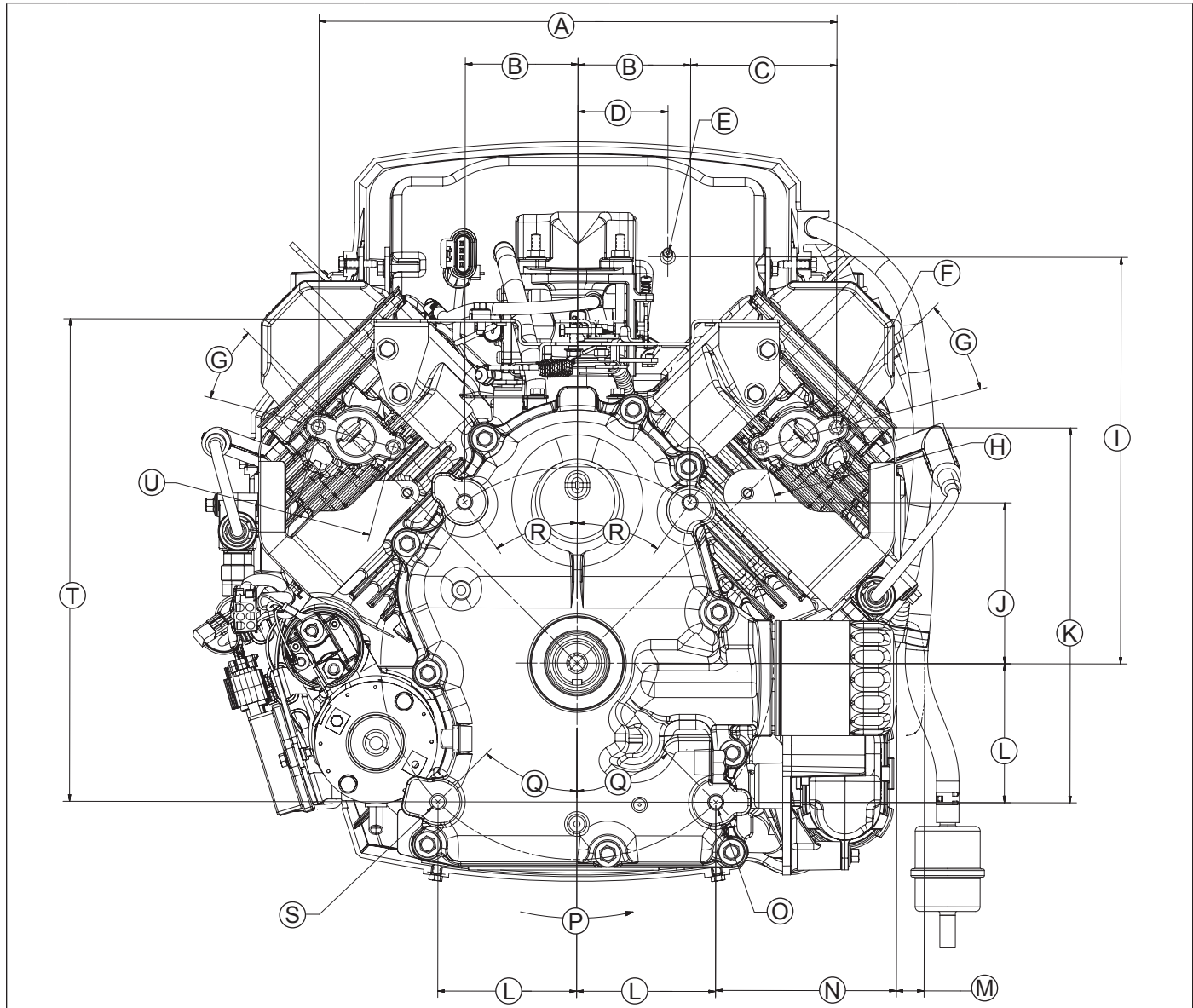

A	334.8 mm (13.18 in.)	B	72.8 mm (2.87 in.)	C	94.5 mm (3.72 in.)	D	58.2 mm (2.29 in.)
E	Evap Connection Point	F	4 X 5/16-18 UNC-2B in. 16.5 mm (0.649 in.) Deep No Studs	G	30°	H	50 mm (1.97 in.) Exhaust Port #2
I	262.8 mm (10.35 in.)	J	104 mm (4.10 in.)	K	242.3 mm (9.54 in.)	L	89.8 mm (3.54 in.)
M	18 mm (0.71 in.) Oil Filter Removal	N	116.8 mm (4.60 in.)	O	Mounting Hole "A"	P	Rotation Direction
Q	45°	R	35°	S	4 X 9.005 mm (0.355 in.) 37 mm (1.46 in.) Deep on a Ø 254 mm (10.0 in.) B.C.	T	312.0 mm (12.28 in.) Throttle and Choke Cable Mounting Surface
U	50 mm (1.97 in.) Exhaust Port #1						

Engine Dimensions-with Low Profile Air Cleaner-Starter Side

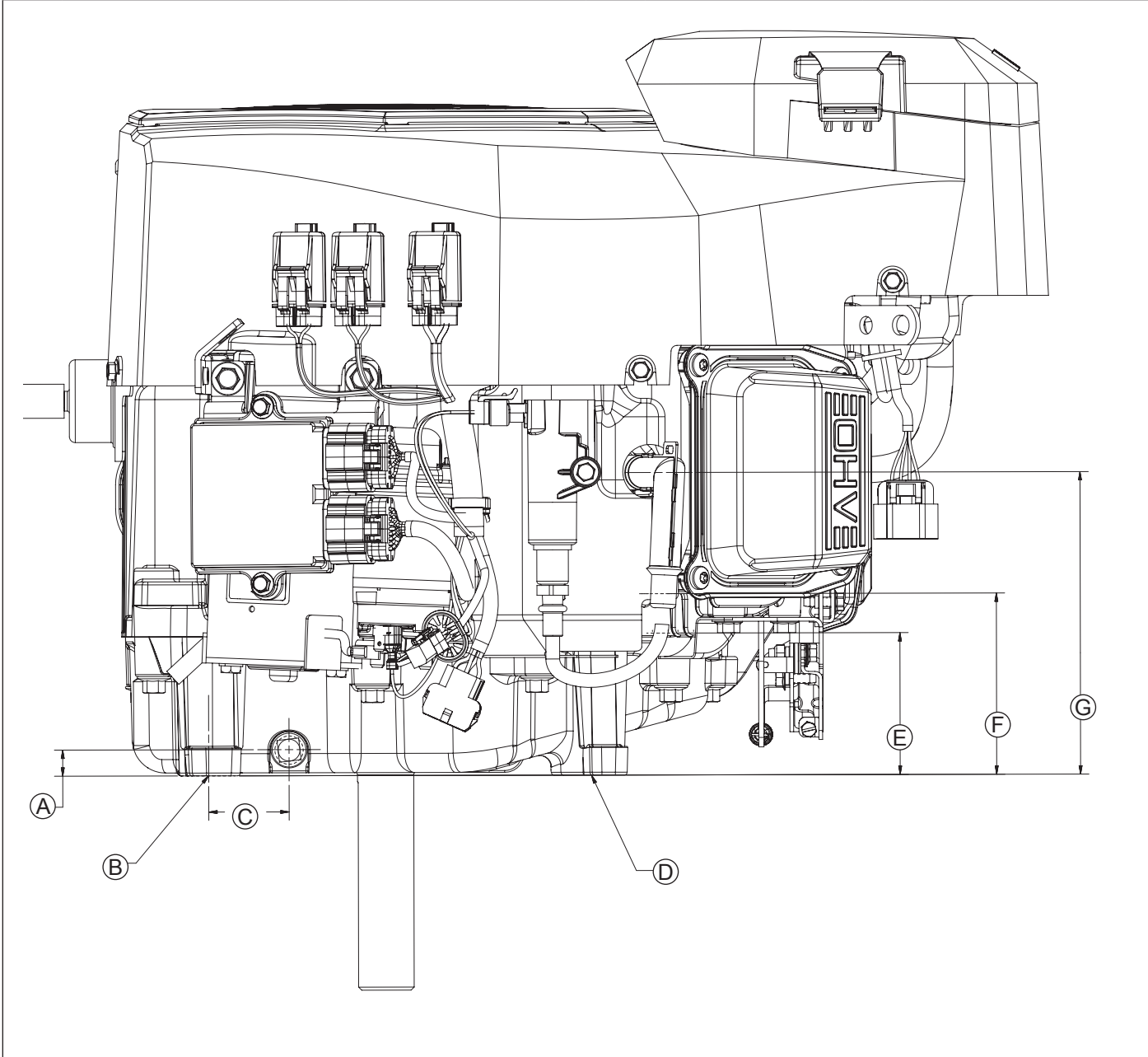

A	13.2 mm (0.52 in.)	B	Mounting Hole "A"	C	40.8 mm (1.61 in.)	D	Engine Mounting Surface
E	72.0 mm (2.83 in.) Exhaust Port #2	F	92.0 mm (3.62 in.) Exhaust Port #1	G	153.5 mm (6.04 in.) Spark Plug Center Line		

Specifications

Engine Dimensions-with Low Profile Air Cleaner-Valve Cover Side

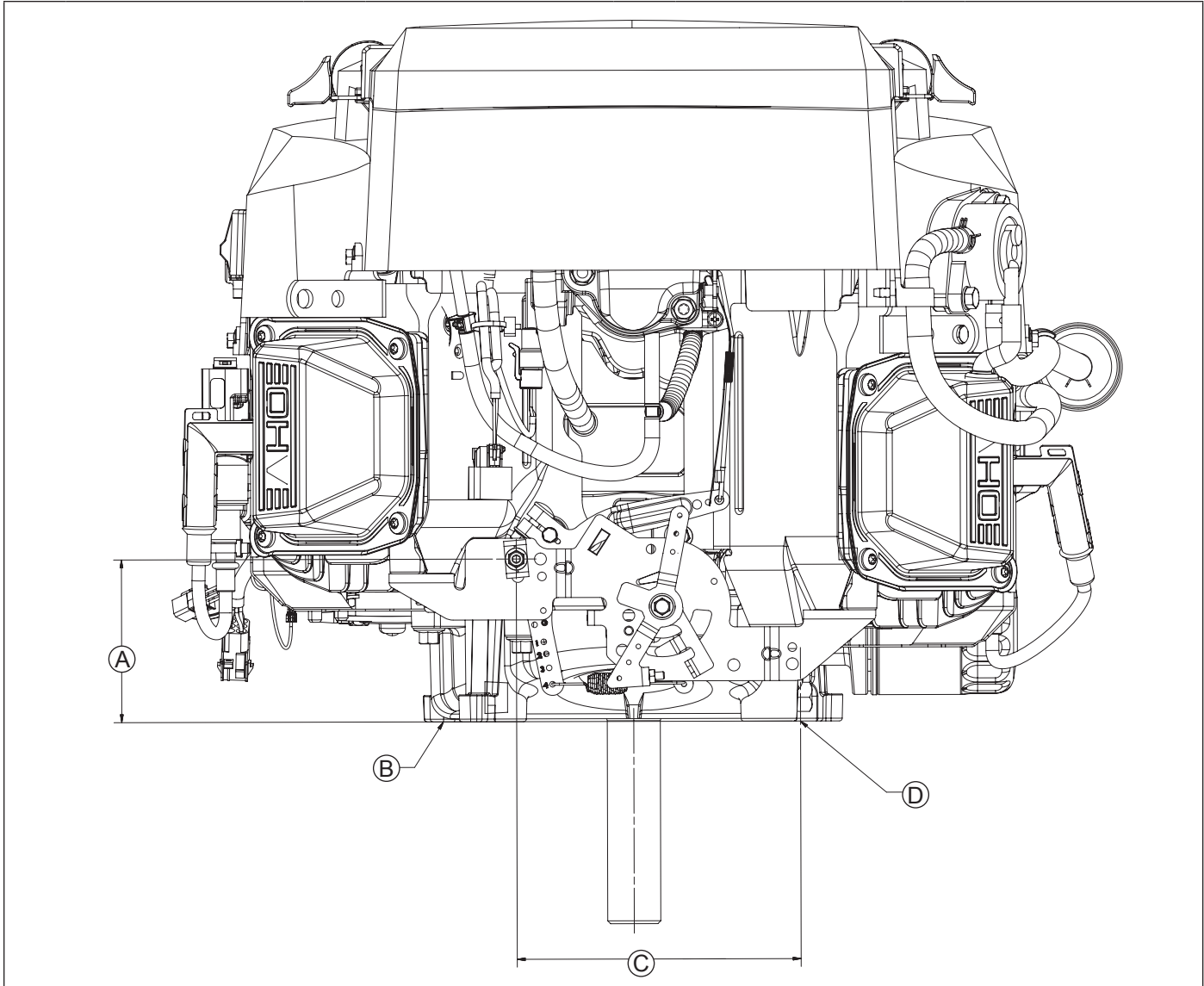

A	87.6 mm (3.45 in.)	B	Engine Mounting Surface	C	152.9 mm (6.02 in.)	D	Mounting Hole "A"
----------	--------------------	----------	-------------------------	----------	---------------------	----------	-------------------

ENGINE IDENTIFICATION NUMBERS

Rehiko engine identification numbers (model, specification and serial) should be referenced for efficient repair, ordering correct parts, and engine replacement.

Model	EZT715
EFI Confidant Engine	
Numerical Designation	
Specification	EZT715-0001
Serial	4823500328
Year Manufactured Code	
Factory Code	
<u>Code</u>	<u>Year</u>
48	2018
49	2019
50	2020

GENERAL SPECIFICATIONS^{3,4}

	EZT715	EZT725	EZT740	EZT750
Bore	83 mm (3.27 in.)			
Stroke	67 mm (2.64 in.)		69 mm (2.72 in.)	
Displacement	725 cc (44 cu. in.)		747 cc (46 cu. in.)	
Oil Capacity (refill)	1.9 L (2.0 U.S. qt.)			
Maximum Angle of Operation (@ full oil level) ⁵	25°			

TORQUE SEQUENCES

(Refer to Torque Specifications for torque values).

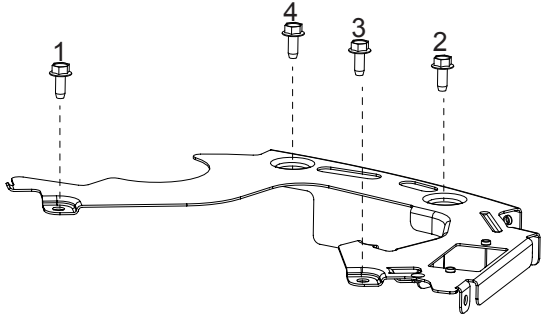
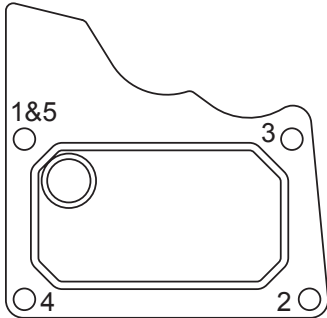
	EZT715	EZT725	EZT740	EZT750
Backing Plate Fasteners				
Breather Cover Fasteners				

³ Values are in Metric units. Values in parentheses are English equivalents.

⁴ Any and all horsepower (hp) references by Rehiko are Certified Power Ratings and per SAE J1940 & J1995 hp standards. Details on Certified Power Ratings can be found at Engines.rehiko.com.

⁵ Exceeding maximum angle of operation may cause engine damage from insufficient lubrication.

Specifications

TORQUE SEQUENCES

EZT715 EZT725 EZT740 EZT750

(Refer to Torque Specifications for torque values).

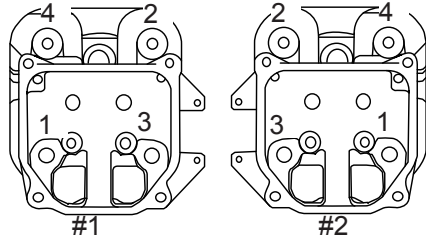
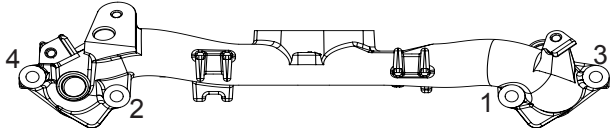
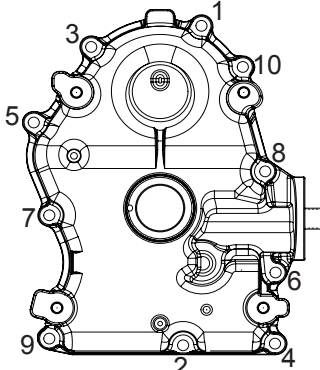
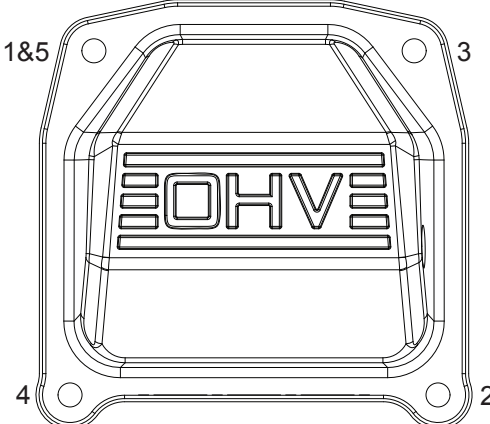
Cylinder Head Bolt Fasteners	
Intake Manifold Mounting Fasteners	
Oil Pan Fasteners	
Valve Cover Fasteners Same torque sequence is used for stamped steel and plastic valve covers.	

TORQUE SPECIFICATIONS^{3,6}

EZT715 EZT725 EZT740 EZT750

Backing Plate (torque sequence on page 15)

Fasteners	7.3 N·m (65 in. lb.)
Dipstick Tube Fastener	3.4 N·m (30 in. lb.)

Baffle and Sheet Metal into Aluminum

M5 Thread Forming Fasteners	8.5 N·m (75 in. lb.) into new hole 4.0 N·m (35 in. lb.) into used hole
M6 Thread Forming Fasteners	10.7 N·m (95 in. lb.) into new hole 7.3 N·m (65 in. lb.) into used hole

³ Values are in Metric units. Values in parentheses are English equivalents.

⁶ Lubricate threads with engine oil prior to assembly.

TORQUE SPECIFICATIONS^{3,6}

EZT715
EZT725
EZT740
EZT750

Blower Housing and Sheet Metal

M3 HI-LO Screw	2.3 N·m (20 in. lb.)
M4 HI-LO Screw	2.8 N·m (25 in. lb.)
M5 Thread Forming Fasteners	3.4 N·m (30 in. lb.)

Chopper Screen (Metal)

Fan Fastener	10.0 N·m (88 in. lb.)
Screen Fastener	4.0 N·m (35 in. lb.)
Metal Guard Fastener	2.6 N·m (23 in. lb.)

Connecting Rod

Cap Fastener (torque in increments)	13.6 N·m (120 in. lb.)
-------------------------------------	------------------------

Crankcase

Breather Assembly Breather Reed Cover Stud	6.2 N·m (55 in. lb.) into new hole 4.0 N·m (35 in. lb.) into used hole
Breather Reed Cover Hex Nut	1.3 N·m (12 in. lb.)
Breather Cover Fasteners (torque sequence on page 15)	6.2 N·m (55 in. lb.) into new hole 4.0 N·m (35 in. lb.) into used hole
Engine Temperature Sensor	11.9 N·m (105 in. lb.)
Oil Drain Plug	13.6 N·m (10 ft. lb.)

Cylinder Head (torque sequence on page 16)

Head Bolt Fasteners (torque in 2 increments)	first to 22.6 N·m (200 in. lb.) finally to 41.8 N·m (370 in. lb.)
Rocker Arm Stud	11.3 N·m (100 in. lb.)
Rocker Arm Adjuster Setscrew	7.9 N·m (70 in. lb.)

Flywheel

Retaining Screw	74.5 N·m (55 ft. lb.)
-----------------	-----------------------

Fuel Pump

Module Baffle Fastener	11.9 N·m (105 in. lb.) into new hole 7.8 N·m (69 in. lb.) into used hole
Module Fastener	9.2 N·m (81 in. lb.)
Pulse Pump to Blower Housing	2.8 N·m (25 in. lb.)

Governor

Lever Nut	6.8 N·m (60 in. lb.)
-----------	----------------------

Ignition

Spark Plug	27 N·m (20 ft. lb.)
Coil Fastener	10.2 N·m (90 in. lb.)
Electronic Control Unit (ECU) Fastener	6.2 N·m (55 in. lb.) into new hole 4.0 N·m (35 in. lb.) into used hole
Rectifier-Regulator Fastener	3.4 N·m (30 in. lb.)
Crankshaft Position Sensor to Bracket Screw	11.3 N·m (100 in. lb.)
Crankshaft Position Sensor Bracket to Crankcase Screw	8.3 N·m (73 in. lb.)

³ Values are in Metric units. Values in parentheses are English equivalents.

⁶ Lubricate threads with engine oil prior to assembly.

Specifications

TORQUE SPECIFICATIONS^{3,6}

EZT715

EZT725

EZT740

EZT750

Intake Manifold (torque sequence on page 16)

Mounting Fasteners	10.5 N·m (93 in. lb.)
Temperature/Manifold Absolute Pressure (TMAP) Sensor Fastener	7.3 N·m (65 in. lb.)
Air Cleaner Base to Throttle Body Nut	6.8 N·m (60 in. lb.)
Air Cleaner Base Side Screw	7.3 N·m (65 in. lb.)
Air Cleaner Base Bracket/Lifting Strap Screw	10.7 N·m (95 in. lb.) into new holes 7.3 N·m (65 in. lb.) into used holes
Fuel Injector Cap Fastener	7.3 N·m (65 in. lb.)
Ground Wire Fastener	7.3 N·m (65 in. lb.)

Muffler

Muffler Bracket Fastener	9.9 N·m (88 in. lb.)
Lock Nut	27.8 N·m (246 in. lb.)
Hex Nut	24.4 N·m (216 in. lb.)
Oxygen Sensor	18 N·m (159 in. lb.)

Oil Pan (torque sequence on page 16)

Fasteners	25.7 N·m (227 in. lb.)
-----------	------------------------

Oil Pump

Screw (no torque sequence)	9.9 N·m (88 in. lb.)
----------------------------	----------------------

Oil Sentry™

Pressure Switch	4.5 N·m (40 in. lb.)
-----------------	----------------------

Retractable Starter

Mounting Screw	7.3 N·m (65 in. lb.)
Center Screw	5.0-6.0 N·m (44-54 in. lb.)

Speed Control Bracket

Fastener	10.7 N·m (95 in. lb.) into new holes 7.3 N·m (65 in. lb.) into used holes
----------	--

Starter Assembly

Mounting Screw	23.8 N·m (211 in. lb.)
----------------	------------------------

Stator

Mounting Screw	8.8 N·m (78 in. lb.)
----------------	----------------------

Valve Cover (torque sequence on page 16)

Stamped Steel Cover Fasteners	13.6 N·m (120 in. lb.)
Plastic Cover Fastener	
Hex Flange	9.0 N·m (80 in. lb.)
Pan Head	6.2 N·m (55 in. lb.)

³ Values are in Metric units. Values in parentheses are English equivalents.

⁶ Lubricate threads with engine oil prior to assembly.

CLEARANCE SPECIFICATIONS³

EZT715
EZT725
EZT740
EZT750

Camshaft

End Play	0.06/0.40 mm (0.0024/0.0157 in.)
Running Clearance	0.040/0.077 mm (0.0016/0.0030 in.)
Bore I.D. New Max. Wear Limit	20.000/20.025 mm (0.7874/0.7884 in.) 20.038 mm (0.7889 in.)
Bearing Surface O.D. New Max. Wear Limit	19.948/19.960 mm (0.7854/0.7858 in.) 19.945 mm (0.7852 in.)

Connecting Rod

Connecting Rod-to-Crankpin Running Clearance New Max. Wear Limit	0.037/0.083 mm (0.0015/0.0033 in.) 0.098 mm (0.0039 in.)
Connecting Rod-to-Crankpin Side Clearance	0.261/0.67 mm (0.0102/0.0264 in.)
Connecting Rod-to-Piston Pin Running Clearance	0.013/0.032 mm (0.0005/0.0013 in.)
Piston Pin End I.D. New Max. Wear Limit	17.013/17.027 mm (0.6698/0.6704 in.) 17.040 mm (0.6709 in.)

Crankcase

Governor Cross Shaft Bore I.D. New Max. Wear Limit	8.025/8.075 mm (0.3159/0.3179 in.) 8.088 mm (0.3184 in.)
--	---

Crankshaft

End Play (free)	0.075/0.595 mm (0.0030/0.023 in.)
Bore (in crankcase) New Max. Wear Limit	40.974/40.987 mm (1.6131/1.6137 in.) 41.000 mm (1.6142 in.)
Bore (in oil pan) New	40.974/41.000 mm (1.6131/1.6142 in.)
Crankshaft Bore (in oil pan)-to-Crankshaft Running Clearance New	0.039/0.087 mm (0.0015/0.0034 in.)
Flywheel End Main Bearing Journal O.D. - New O.D. - Max. Wear Limit Max. Taper Max. Out-of-Round	40.913/40.935 mm (1.6107/1.6116 in.) 40.840 mm (1.608 in.) 0.022 mm (0.0009 in.) 0.025 mm (0.0010 in.)
Oil Pan End Main Bearing Journal O.D. - New O.D. - Max. Wear Limit Max. Taper Max. Out-of-Round	40.913/40.935 mm (1.6107/1.6116 in.) 40.840 mm (1.608 in.) 0.022 mm (0.0009 in.) 0.025 mm (0.0010 in.)
Connecting Rod Journal O.D. - New O.D. - Max. Wear Limit Max. Taper Max. Out-of-Round	35.950/35.974 mm (1.4154/1.4163 in.) 35.950 mm (1.4154 in.) 0.018 mm (0.0007 in.) 0.025 mm (0.0010 in.)
T.I.R. PTO End, Crank in Engine Entire Crank, in V-Blocks	0.279 mm (0.0110 in.) 0.200 mm (0.0079 in.)

³ Values are in Metric units. Values in parentheses are English equivalents.

Specifications

CLEARANCE SPECIFICATIONS³

EZT715

EZT725

EZT740

EZT750

Cylinder Bore

Bore I.D. New Max. Wear Limit Max. Out-of-Round Max. Taper	83.006/83.031 mm (3.2679 in./3.2689 in.) 83.069 mm (3.2704 in.) 0.120 mm (0.0047 in.) 0.050 mm (0.0020 in.)
--	--

Cylinder Head

Max. Out-of-Flatness	0.076 mm (0.003 in.)
----------------------	----------------------

Governor

Cross Shaft End Play	0.025/3.15 mm (0.0010/0.124 in.)
Governor Cross Shaft-to-Crankcase Running Clearance	0.025/0.126 mm (0.0009/0.0049 in.)
Cross Shaft O.D. New Max. Wear Limit	7.949/8.000 mm (0.3129/0.3149 in.) 7.936 mm (0.3124 in.)
Governor Gear Shaft-to-Governor Running Clearance	0.050/0.210 mm (0.0020/0.0083 in.)
Gear Shaft O.D. New Max. Wear Limit	5.990/6.000 mm (0.2358/0.2362 in.) 5.977 mm (0.2353 in.)

Ignition

Spark Plug Gap	0.76 mm (0.030 in.)
----------------	---------------------

Piston, Piston Rings, and Piston Pin

Piston-to-Piston Pin Running Clearance	0.006/0.017 mm (0.0002/0.0007 in.)
Pin Bore I.D. New Max. Wear Limit	17.006/17.012 mm (0.6695/0.6698 in.) 17.025 mm (0.6703 in.)
Pin O.D. New Max. Wear Limit	16.995/17.000 mm (0.6691/0.6693 in.) 16.994 mm (0.6691 in.)
Top Compression Ring-to-Groove Side Clearance	0.030/0.070 mm (0.0010/0.0026 in.)
Middle Compression Ring-to-Groove Side Clearance	0.030/0.070 mm (0.0010/0.0026 in.)
Oil Control Ring-to-Groove Side Clearance	0.060/0.190 mm (0.0022/0.0073 in.)
Top Compression Ring End Gap New Bore Used Bore (Max.)	0.189/0.277 mm (0.0074/0.0109 in.) 0.531 mm (0.0209 in.)
Center Compression Ring End Gap New Bore Used Bore (Max.)	1.519/1.797 mm (0.0598/0.0708 in.) 2.051 mm (0.0808 in.)
Thrust Face O.D. ⁷ New Max. Wear Limit	82.978 mm (3.2668 in.) 82.833 mm (3.2611 in.)
Piston Thrust Face-to-Cylinder Bore ⁷ Running Clearance New	0.019/0.062 mm (0.0007/0.0024 in.)

³ Values are in Metric units. Values in parentheses are English equivalents.

⁷ Measure 6 mm (0.2362 in.) above bottom of piston skirt at right angles to piston pin.

CLEARANCE SPECIFICATIONS³



EZT715
EZT725
EZT740
EZT750
Valves and Valve Tappets

Clearance	0.127/0.178 mm (0.0050/0.0070 in.)
Valve Tappet to Crankcase Running Clearance	0.013/0.073 mm (0.0005/0.0029 in.)
Intake Valve Stem-to-Valve Guide Running Clearance	0.040/0.0780 mm (0.0016/0.0031 in.)
Exhaust Valve Stem-to-Valve Guide Running Clearance	0.052/0.090 mm (0.0020/0.0035 in.)
Intake Valve Guide I.D. New Max. Wear Limit	7.040/7.060 mm (0.2772/0.2780 in.) 7.140 mm (0.2811 in.)
Exhaust Valve Guide I.D. New Max. Wear Limit	7.040/7.060 mm (0.2772/0.2780 in.) 7.160 mm (0.2819 in.)
Valve Guide Reamer Size Standard 0.25 mm O.S.	7.050 mm (0.2776 in.) 7.300 mm (0.2874 in.)
Intake Valve Minimum Lift	8.500 mm (0.3346 in.)
Exhaust Valve Minimum Lift	8.500 mm (0.3346 in.)
Nominal Valve Face Angle	45°





³ Values are in Metric units. Values in parentheses are English equivalents.

Specifications

GENERAL TORQUE VALUES

English Fastener Torque Recommendations for Standard Applications				
Bolts, Screws, Nuts and Fasteners Assembled Into Cast Iron or Steel				Grade 2 or 5 Fasteners Into Aluminum
Size	 Grade 2	 Grade 5	 Grade 8	
Tightening Torque: N·m (in. lb.) ± 20%				
8-32	2.3 (20)	2.8 (25)	—	2.3 (20)
10-24	3.6 (32)	4.5 (40)	—	3.6 (32)
10-32	3.6 (32)	4.5 (40)	—	—
1/4-20	7.9 (70)	13.0 (115)	18.7 (165)	7.9 (70)
1/4-28	9.6 (85)	15.8 (140)	22.6 (200)	—
5/16-18	17.0 (150)	28.3 (250)	39.6 (350)	17.0 (150)
5/16-24	18.7 (165)	30.5 (270)	—	—
3/8-16	29.4 (260)	—	—	—
3/8-24	33.9 (300)	—	—	—

Tightening Torque: N·m (ft. lb.) ± 20%				
5/16-24	—	—	40.7 (30)	—
3/8-16	—	47.5 (35)	67.8 (50)	—
3/8-24	—	54.2 (40)	81.4 (60)	—
7/16-14	47.5 (35)	74.6 (55)	108.5 (80)	—
7/16-20	61.0 (45)	101.7 (75)	142.5 (105)	—
1/2-13	67.8 (50)	108.5 (80)	155.9 (115)	—
1/2-20	94.9 (70)	142.4 (105)	223.7 (165)	—
9/16-12	101.7 (75)	169.5 (125)	237.3 (175)	—
9/16-18	135.6 (100)	223.7 (165)	311.9 (230)	—
5/8-11	149.5 (110)	244.1 (180)	352.6 (260)	—
5/8-18	189.8 (140)	311.9 (230)	447.5 (330)	—
3/4-10	199.3 (147)	332.2 (245)	474.6 (350)	—
3/4-16	271.2 (200)	440.7 (325)	637.3 (470)	—

Metric Fastener Torque Recommendations for Standard Applications						
Size	Property Class					Noncritical Fasteners Into Aluminum
	 4.8	 5.8	 8.8	 10.9	 12.9	
Tightening Torque: N·m (in. lb.) ± 10%						
M4	1.2 (11)	1.7 (15)	2.9 (26)	4.1 (36)	5.0 (44)	2.0 (18)
M5	2.5 (22)	3.2 (28)	5.8 (51)	8.1 (72)	9.7 (86)	4.0 (35)
M6	4.3 (38)	5.7 (50)	9.9 (88)	14.0 (124)	16.5 (146)	6.8 (60)
M8	10.5 (93)	13.6 (120)	24.4 (216)	33.9 (300)	40.7 (360)	17.0 (150)
Tightening Torque: N·m (ft. lb.) ± 10%						
M10	21.7 (16)	27.1 (20)	47.5 (35)	66.4 (49)	81.4 (60)	33.9 (25)
M12	36.6 (27)	47.5 (35)	82.7 (61)	116.6 (86)	139.7 (103)	61.0 (45)
M14	58.3 (43)	76.4 (56)	131.5 (97)	184.4 (136)	219.7 (162)	94.9 (70)

Torque Conversions	
N·m = in. lb. x 0.113	in. lb. = N·m x 8.85
N·m = ft. lb. x 1.356	ft. lb. = N·m x 0.737

Certain quality tools are designed to help you perform specific disassembly, repair, and reassembly procedures. By using these tools, you can properly service engines easier, faster, and safer! In addition, you'll increase your service capabilities and customer satisfaction by decreasing engine downtime.

Here is a list of tools and their source.

SEPARATE TOOL SUPPLIERS

Rehiko Tools
Contact your local Rehiko source of supply.

SE Tools
415 Howard St.
Lapeer, MI 48446
Phone 810-664-2981
Toll Free 800-664-2981
Fax 810-664-8181

Design Technology Inc.
768 Burr Oak Drive
Westmont, IL 60559
Phone 630-920-1300
Fax 630-920-0011

TOOLS

Description	Source/Part No.
Alcohol Content Tester For testing alcohol content (%) in reformulated/oxygenated fuels.	Rehiko 25 455 11-S
Camshaft Endplay Plate For checking camshaft endplay.	SE Tools KLR-82405
Camshaft Seal Protector (Aegis) For protecting seal during camshaft installation.	SE Tools KLR-82417
Cylinder Leakdown Tester For checking combustion retention and if cylinder, piston, rings, or valves are worn. Individual component available: Adapter 12 mm x 14 mm (Required for leakdown test on XT-6 engines)	Rehiko 25 761 05-S Design Technology Inc. DTI-731-03
Dealer Tool Kit (Domestic) Complete kit of Rehiko required tools. Components of 25 761 39-S Ignition System Tester Cylinder Leakdown Tester Oil Pressure Test Kit Rectifier-Regulator Tester (120 V AC/60Hz)	Rehiko 25 761 39-S Rehiko 25 455 01-S Rehiko 25 761 05-S Rehiko 25 761 06-S Rehiko 25 761 20-S
Dealer Tool Kit (International) Complete kit of Rehiko required tools. Components of 25 761 42-S Ignition System Tester Cylinder Leakdown Tester Oil Pressure Test Kit Rectifier-Regulator Tester (240 V AC/50Hz)	Rehiko 25 761 42-S Rehiko 25 455 01-S Rehiko 25 761 05-S Rehiko 25 761 06-S Rehiko 25 761 41-S
Digital Vacuum/Pressure Tester For checking crankcase vacuum. Individual component available: Rubber Adapter Plug	Design Technology Inc. DTI-721-01 Design Technology Inc. DTI-721-10
Electronic Fuel Injection (EFI) Diagnostic Software For Laptop or Desktop PC.	Rehiko 25 761 23-S
EFI Service Kit For troubleshooting and setting up an EFI engine. Components of 24 761 01-S Fuel Pressure Tester Noid Light 90° Adapter Code Plug, Red Wire Code Plug, Blue Wire Shrader Valve Adapter Hose Wire Probe Set (2 pieces regular wire with clip; 1 piece fused wire) Hose Removal Tool, Dual Size/End (also sold as individual Rehiko tool)	Rehiko 24 761 01-S Design Technology Inc. DTI-019 DTI-021 DTI-023 DTI-027 DTI-029 DTI-037 DTI-031 DTI-033
Flywheel Puller For properly removing flywheel from engine.	SE Tools KLR-82408

Tools and Aids

TOOLS

Description	Source/Part No.
Hose Removal Tool, Dual Size/End (also available in EFI Service Kit) Used to properly remove fuel hose from engine components.	Rehlko 25 455 20-S
Hydraulic Valve Lifter Tool For removing and installing hydraulic lifters.	Rehlko 25 761 38-S
Ignition System Tester For testing output on all systems, including CD.	Rehlko 25 455 01-S
Inductive Tachometer (Digital) For checking operating speed (RPM) of an engine.	Design Technology Inc. DTI-110
Offset Wrench (K and M Series) For removing and reinstalling cylinder barrel retaining nuts.	Rehlko 52 455 04-S
Oil Pressure Test Kit For testing/verifying oil pressure on pressure lubricated engines.	Rehlko 25 761 06-S
Rectifier-Regulator Tester (120 volt current) Rectifier-Regulator Tester (240 volt current) For testing rectifier-regulators. Components of 25 761 20-S and 25 761 41-S CS-PRO Regulator Test Harness Special Regulator Test Harness with Diode	Rehlko 25 761 20-S Rehlko 25 761 41-S Design Technology Inc. DTI-031R DTI-033R
Spark Advance Module (SAM) Tester For testing SAM (ASAM and DSAM) on engines with SMART-SPARK™.	Rehlko 25 761 40-S
Starter Servicing Kit (All Starters) For removing and reinstalling drive retaining rings and brushes. Individual component available: Starter Brush Holding Tool (Solenoid Shift)	SE Tools KLR-82411 SE Tools KLR-82416
Triad/OHC Timing Tool Set For holding cam gears and crankshaft in timed position while installing timing belt.	Rehlko 28 761 01-S
Valve Guide Reamer (K and M Series) For properly sizing valve guides after installation.	Design Technology Inc. DTI-K828
Valve Guide Reamer O.S. (Command Series) For reaming worn valve guides to accept replacement oversize valves. Can be used in low-speed drill press or with handle below for hand reaming.	Rehlko 25 455 12-S
Reamer Handle For hand reaming using Rehlko 25 455 12-S reamer.	Design Technology Inc. DTI-K830

AIDS

Description	Source/Part No.
Camshaft Lubricant (Valspar ZZ613)	Rehlko 25 357 14-S
Dielectric Grease (GE/Novaguard G661)	Rehlko 25 357 11-S
Dielectric Grease	Loctite® 51360
Rehlko Electric Starter Drive Lubricant (Inertia Drive)	Rehlko 52 357 01-S
Rehlko Electric Starter Drive Lubricant (Solenoid Shift)	Rehlko 52 357 02-S
RTV Silicone Sealant Loctite® 5900® Heavy Body in 4 oz. aerosol dispenser. Only oxime-based, oil resistant RTV sealants, such as those listed, are approved for use. Permatex® the Right Stuff® 1 Minute Gasket™ or Loctite® Nos. 5900® or 5910® are recommended for best sealing characteristics.	Rehlko 25 597 07-S Loctite® 5910® Loctite® Ultra Black 598™ Loctite® Ultra Blue 587™ Loctite® Ultra Copper 5920™ Permatex® the Right Stuff® 1 Minute Gasket™
Spline Drive Lubricant	Rehlko 25 357 12-S

FLYWHEEL HOLDING TOOL

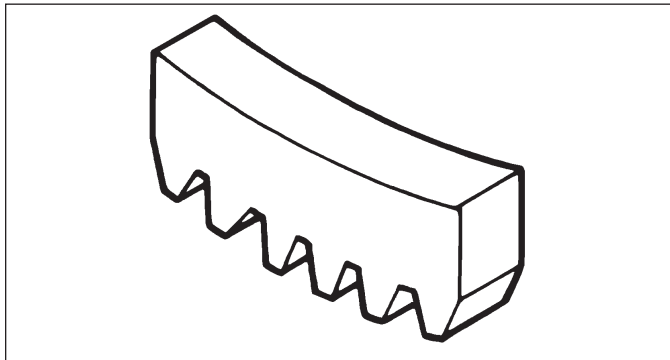

A flywheel holding tool can be made out of an old junk flywheel ring gear and used in place of a strap wrench.

1. Using an abrasive cut-off wheel, cut out a six tooth segment of ring gear as shown.
2. Grind off any burrs or sharp edges.
3. Invert segment and place it between ignition bosses on crankcase so tool teeth engage flywheel ring gear teeth. Bosses will lock tool and flywheel in position for loosening, tightening, or removing with a puller.

ROCKER ARM/CRANKSHAFT TOOL

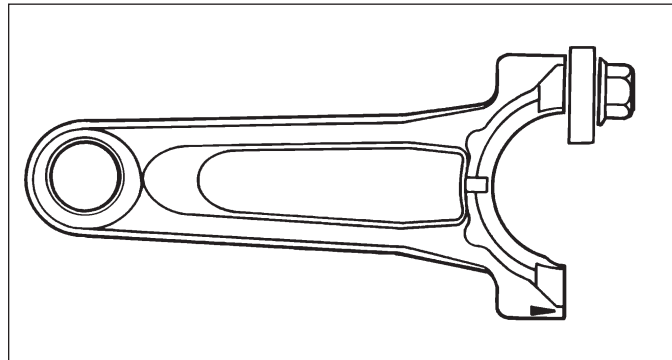

A spanner wrench to lift rocker arms or turn crankshaft may be made out of an old junk connecting rod.

1. Find a used connecting rod from a 10 HP or larger engine. Remove and discard rod cap.
2. Remove studs of a Posi-Lock rod or grind off aligning steps of a Command rod, so joint surface is flat.
3. Find a 1 in. long capscrew with correct thread size to match threads in connecting rod.
4. Use a flat washer with correct I.D. to slip on capscrew and approximately 1 in. O.D. Assemble capscrew and washer to joint surface of rod.

Troubleshooting

TROUBLESHOOTING GUIDE

When troubles occur, be sure to check simple causes which, at first, may seem too obvious to be considered. For example, a starting problem could be caused by an empty fuel tank.

Some general common causes of EFI engine troubles are listed below and vary by engine specification. Use these to locate causing factors.

Engine Cranks But Will Not Start

- Battery connected backwards.
- Blown fuses.
- Clogged fuel line or fuel filter.
- Empty fuel tank.
- Faulty ignition coil(s).
- Faulty spark plug(s).
- Fuel pump malfunction-vacuum hose clogged or leaking.
- Fuel shut-off valve closed.
- Insufficient voltage to electronic control unit.
- Interlock switch is engaged or faulty.
- Key switch or kill switch in OFF position.
- Low oil level.
- Quality of fuel (dirt, water, stale, mixture).
- Spark plug lead(s) disconnected.

Engine Starts But Does Not Keep Running

- Faulty cylinder head gasket.
- Faulty or misadjusted throttle controls.
- Fuel pump malfunction-vacuum hose clogged or leaking.
- Intake system leak.
- Loose wires or connections that intermittently ground ignition kill circuit.
- Quality of fuel (dirt, water, stale, mixture).
- Restricted fuel tank cap vent.

Engine Starts Hard

- Clogged fuel line or fuel filter.
- Engine overheated.
- Faulty ACR mechanism (Recoil Start).
- Faulty spark plug(s).
- Flywheel key sheared.
- Fuel pump malfunction-vacuum hose clogged or leaking.
- Interlock switch is engaged or faulty.
- Loose wires or connections that intermittently ground ignition kill circuit.
- Low compression.
- Quality of fuel (dirt, water, stale, mixture).
- Weak spark.

Engine Will Not Crank

- Battery is discharged.
- Faulty electric starter or solenoid.
- Faulty key switch or ignition switch.
- Interlock switch is engaged or faulty.
- Loose wires or connections that intermittently ground ignition kill circuit.
- Pawls not engaging in drive cup (Recoil Start).
- Seized internal engine components.

Engine Runs But Misses

- Fuel system issue (Fuel Injectors).
- Engine overheated.
- Faulty spark plug(s).
- Ignition module(s) faulty.
- Incorrect crankshaft position sensor air gap.
- Interlock switch is engaged or faulty.
- Loose wires or connections that intermittently ground ignition kill circuit.
- Quality of fuel (dirt, water, stale, mixture).
- Spark plug lead(s) disconnected.
- Spark plug lead boot loose on plug.
- Spark plug lead loose.

Engine Will Not Idle

- Engine overheated.
- Faulty spark plug(s).
- Idle speed adjusting screw improperly set.
- Inadequate fuel supply.
- Low compression.
- Quality of fuel (dirt, water, stale, mixture).
- Restricted fuel tank cap vent.

Engine Overheats

- Cooling fan broken.
- Excessive engine load.
- High crankcase oil level.
- Lean fuel mixture.
- Low crankcase oil level.
- Cooling system components clogged or restricted.

Engine Knocks

- Excessive engine load.
- Hydraulic lifter malfunction or incorrect valve lash adjustment.
- Incorrect oil viscosity/type.
- Internal wear or damage.
- Low crankcase oil level.
- Quality of fuel (dirt, water, stale, mixture).
- Loose/worn pulley/clutch on crankshaft PTO.

Engine Loses Power

- Dirty air cleaner element.
- Engine overheated.
- Excessive engine load.
- Restricted exhaust.
- Faulty spark plug(s).
- High crankcase oil level.
- Incorrect governor setting.
- Low battery.
- Low compression.
- Low crankcase oil level.
- Quality of fuel (dirt, water, stale, mixture).

Engine Uses Excessive Amount of Oil

- Loose or improperly torqued fasteners.
- Blown head gasket/overheated.
- Breather reed broken.
- Clogged, broken, or inoperative crankcase breather.
- Crankcase overfilled.
- Incorrect oil viscosity/type.
- Worn cylinder bore.
- Worn or broken piston rings.
- Worn valve stems/valve guides.

Oil Leaks from Oil Seals, Gaskets

- Breather reed broken.
- Clogged, broken, or inoperative crankcase breather.
- Loose or improperly torqued fasteners.
- Piston blow by, or leaky valves.
- Restricted exhaust.

EXTERNAL ENGINE INSPECTION

NOTE: It is good practice to drain oil at a location away from workbench. Be sure to allow ample time for complete drainage.

Before cleaning or disassembling engine, make a thorough inspection of its external appearance and condition. This inspection can give clues to what might be found inside engines (and cause) when it is disassembled.

- Check for buildup of dirt and debris on crankcase, cooling fins, grass screen, and other external surfaces. Dirt or debris on these areas can cause overheating.
- Check for obvious fuel and oil leaks, and damaged components. Excessive oil leakage can indicate a clogged or inoperative breather, worn or damaged seals or gaskets, or loose fasteners.
- Check air cleaner cover and base for damage or indications of improper fit and seal.
- Check air cleaner element. Look for holes, tears, cracked or damaged sealing surfaces, or other damage that could allow unfiltered air into engine. A dirty or clogged element could indicate insufficient or improper maintenance.
- Check throttle body throat for dirt. Dirt in throat is further indication that air cleaner was not functioning properly.
- Check if oil level is within operating range on dipstick. If it is above, sniff for gasoline odor.
- Check condition of oil. Drain oil into a container; it should flow freely. Check for metal chips and other foreign particles.

Sludge is a natural by-product of combustion; a small accumulation is normal. Excessive sludge formation could indicate over rich fuel settings, weak ignition, overextended oil change interval or wrong weight or type of oil was used.

CLEANING ENGINE

	WARNING
	Cleaning Solvents can cause severe injury or death. Use only in well ventilated areas away from ignition sources.
Carburetor cleaners and solvents are extremely flammable. Follow cleaner manufacturer's warnings and instructions on its proper and safe use. Never use gasoline as a cleaning agent.	

After inspecting external condition of engine, clean engine thoroughly before disassembly. Clean individual components as engine is disassembled. Only clean parts can be accurately inspected and gauged for wear or damage. There are many commercially available cleaners that will quickly remove grease, oil, and grime from engine parts. When such a cleaner is used, follow manufacturer's instructions and safety precautions carefully.

Make sure all traces of cleaner are removed before engine is reassembled and placed into operation. Even small amounts of these cleaners can quickly break down lubricating properties of engine oil.

Troubleshooting

CRANKCASE VACUUM TEST

	▲ WARNING
	Carbon Monoxide can cause severe nausea, fainting or death. Avoid inhaling exhaust fumes. Never run engine indoors or in enclosed spaces.
Engine exhaust gases contain poisonous carbon monoxide. Carbon monoxide is odorless, colorless, and can cause death if inhaled.	

	▲ WARNING
	Rotating Parts can cause severe injury. Stay away while engine is in operation.
Keep hands, feet, hair, and clothing away from all moving parts to prevent injury. Never operate engine with covers, shrouds, or guards removed.	

A partial vacuum should be present in crankcase when engine is operating. Pressure in crankcase (normally caused by a clogged or improperly assembled breather) can cause oil to be forced out at oil seals, gaskets, or other available spots.

Crankcase vacuum is best measured with either a water manometer or a vacuum gauge. Complete instructions are provided in kits.

To test crankcase vacuum with manometer:

1. Insert rubber stopper into oil fill hole. Be sure pinch clamp is installed on hose and use tapered adapters to connect hose between stopper and one manometer tube. Leave other tube open to atmosphere. Check that water level in manometer is at 0 line. Make sure pinch clamp is closed.
2. Start engine and run no-load high speed.
3. Open clamp and note water level in tube.
Level in engine side should be a minimum of 10.2 cm (4 in.) above level in open side.
If level in engine side is less than specified (low/no vacuum), or level in engine side is lower than level in open side (pressure), check for conditions in table below.
4. Close pinch clamp before stopping engine.

To test crankcase vacuum with vacuum/pressure gauge:

1. Remove dipstick or oil fill plug/cap.
2. Install adapter into oil fill/dipstick tube opening, upside down over end of a small diameter dipstick tube, or directly into engine if a tube is not used. Insert barbed gauge fitting into hole in stopper.
3. Run engine and observe gauge reading.
Analog tester—needle movement to left of 0 is a vacuum, and movement to right indicates a pressure.
Digital tester—depress test button on top of tester.
Crankcase vacuum should be a minimum of 10.2 cm (4 in.) of water. If reading is below specification, or if pressure is present, check table below for possible causes and conclusions.

Condition	Conclusion
Crankcase breather clogged or inoperative.	NOTE: If breather is integral part of valve cover and cannot be serviced separately, replace valve cover and recheck pressure. Disassemble breather, clean parts thoroughly, check sealing surfaces for flatness, reassemble, and recheck pressure.
Seals and/or gaskets leaking. Loose or improperly torque fasteners.	Replace all worn or damaged seals and gaskets. Make sure all fasteners are tightened securely. Use appropriate torque values and sequences when necessary.
Piston blow by or leaky valves (confirm by inspecting components).	Recondition piston, rings, cylinder bore, valves and valves guides.
Restricted exhaust.	Check exhaust screen/spark arrestor (if equipped). Clean or replace as needed. Repair or replace any other damaged/restricted muffler or exhaust system parts.

COMPRESSION TEST

A compression test is best performed on a warm engine. Clean any dirt or debris away from base of spark plug(s) before removing them. Be sure battery is fully charged, unplug ECU, and throttle is wide open during test. Compression should be at least 160 psi and should not vary more than 15% between cylinders.

Some models (recoil start) are equipped with an automatic compression release (ACR) mechanism. It is difficult to obtain an accurate compression reading because of ACR mechanism. As an alternative, use cylinder leakdown test described below.

CYLINDER LEAKDOWN TEST

A cylinder leakdown test can be a valuable alternative to a compression test. By pressurizing combustion chamber from an external air source you can determine if valves or rings are leaking, and how badly.

Cylinder leakdown tester is a relatively simple, inexpensive leakdown tester for small engines. This tester includes a quick-connect for attaching adapter hose and a holding tool.

1. Run engine for 3-5 minutes to warm it up.
2. Remove spark plug(s) and air filter from engine.
3. Rotate crankshaft until piston (of cylinder being tested) is at top dead center (TDC) of compression stroke. Hold engine in this position while testing. Holding tool supplied with tester can be used if PTO end of crankshaft is accessible. Lock holding tool onto crankshaft. Install a 3/8 in. breaker bar into hole/slot of holding tool, so it is perpendicular to both holding tool and crankshaft PTO.
If flywheel end is more accessible, use a breaker bar and socket on flywheel nut/screw to hold it in position. An assistant may be needed to hold breaker bar during testing. If engine is mounted in a piece of equipment, it may be possible to hold it by clamping or wedging a driven component. Just be certain that engine cannot rotate off of TDC in either direction.
4. Install adapter into spark plug hole, but do not attach it to tester at this time.
5. Turn regulator knob completely counterclockwise.
6. Connect an air source of at least 50 psi to tester.
7. Turn regulator knob clockwise (increase direction) until gauge needle is in yellow set area at low end of scale.
8. Connect tester quick-connect to adapter hose. While firmly holding engine at TDC, gradually open tester valve. Note gauge reading and listen for escaping air at combustion air intake, exhaust outlet, and crankcase breather.

Condition	Conclusion
Air escaping from crankcase breather.	Ring or cylinder worn.
Air escaping from exhaust system.	Defective exhaust valve/improper seating.
Air escaping from intake.	Defective intake valve/improper seating.
Gauge reading in low (green) zone.	Piston rings and cylinder in good condition.
Gauge reading in moderate (yellow) zone.	Engine is still usable, but there is some wear present. Customer should start planning for overhaul or replacement.
Gauge reading in high (red) zone.	Rings and/or cylinder have considerable wear. Engine should be reconditioned or replaced.

Air Cleaner/Intake

AIR CLEANER

These systems are CARB/EPA certified and components should not be altered or modified in any way.

Heavy-Duty Air Cleaner Components

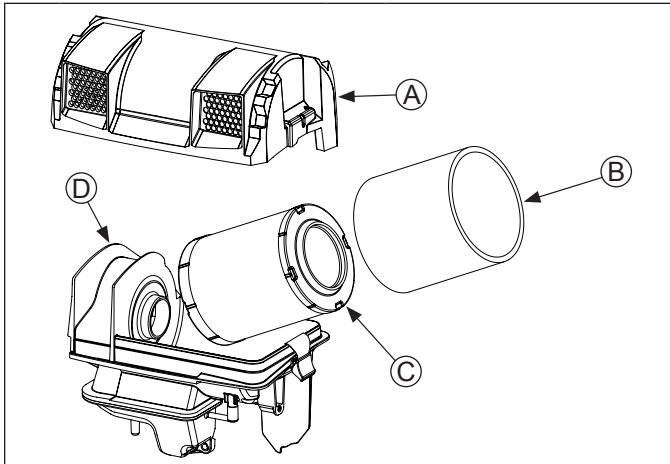

A	Air Cleaner Cover	B	Precleaner
C	Paper Element	D	Air Cleaner Base

Low-Profile Air Cleaner Components

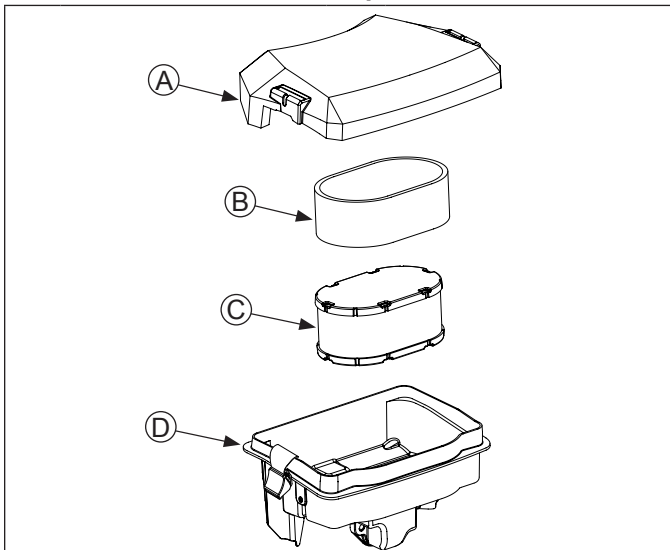

A	Air Cleaner Cover	B	Precleaner
C	Paper Element	D	Air Cleaner Base

NOTE: Operating engine with loose or damaged air cleaner components could cause premature wear and failure. Replace all bent or damaged components.

NOTE: Paper element cannot be blown out with compressed air.

Move bails on air cleaner cover up; remove latches from cover; remove cover.

Precleaner (if equipped)

1. Remove precleaner from paper element.
2. Replace or wash precleaner in warm water with detergent. Rinse and allow to air dry.
3. Lightly oil precleaner with new engine oil; squeeze out excess oil.
4. Reinstall precleaner over paper element.

Paper Element

1. Separate precleaner from element; service precleaner and replace paper element.
2. Install precleaner over new paper element and install on base.

Reinstall cover; place latches onto cover; pull down bails to secure cover.

Air Cleaner Base

Disassembly/Reassembly

If air cleaner base requires removal, proceed as follows:

1. Remove mounting screws for fuel pump (if equipped), and blower housing.
2. Raise or remove blower housing for access to air cleaner base.
3. Remove air cleaner components from base.
4. Remove nuts securing air cleaner base onto mounting studs.
5. Disconnect breather hose from air cleaner base, then remove base and gasket.
6. Reverse procedure to reassemble components. Torque nuts to 6.8 N·m (60 in. lb.). Torque blower housing screws to 4.0 N·m (35 in. lb.), and front HI-LO screws to 2.8 N·m (25 in. lb.).

BREATHER TUBE

Ensure both ends of breather tube are properly connected.

AIR COOLING

	▲ WARNING
	<p>Hot Parts can cause severe burns. Do not touch engine while operating or just after stopping.</p>
<p>Never operate engine with heat shields or guards removed.</p>	

Proper cooling is essential. To prevent over heating, clean screens, cooling fins, and other external surfaces of engine. Avoid spraying water at wiring harness or any electrical components. Refer to Maintenance Schedule.

	▲ WARNING
	<p>Explosive Fuel can cause fires and severe burns.</p> <p>Do not fill fuel tank while engine is hot or running.</p>
<p>Gasoline is extremely flammable and its vapors can explode if ignited. Store gasoline only in approved containers, in well ventilated, unoccupied buildings, away from sparks or flames. Spilled fuel could ignite if it comes in contact with hot parts or sparks from ignition. Never use gasoline as a cleaning agent.</p>	

Typical electronic fuel injection (EFI) system and related components include:

- Fuel pump module and lift pump.
- Fuel filter.
- High pressure fuel line.
- Fuel line(s).
- Fuel injectors.
- Throttle body/intake manifold.
- Electronic control unit (ECU).
- Ignition coils.
- Engine temperature sensor.
- Throttle position sensor (TPS).
- Crankshaft position sensor.
- Oxygen sensor.
- Temperature/Manifold Absolute Pressure (TMAP) sensor.
- Wire harness assembly & affiliated wiring.
- 30 Amp fuse (charging system). OR
- 20 Amp fuse (charging system/recoil start).
- 10 Amp fuse (ignition switch).
- 10 Amp fuse (battery power).
- Malfunction indicator light (MIL) - optional.

FUEL RECOMMENDATIONS

Refer to Maintenance.

FUEL LINE

Low permeation fuel line must be installed on all Rehlko engines to maintain EPA and CARB regulatory compliance.

OPERATION

NOTE: When performing voltage or continuity tests, avoid putting excessive pressure on or against connector pins. Flat pin probes are recommended for testing to avoid spreading or bending terminals.

EFI system is designed to provide peak engine performance with optimum fuel efficiency and lowest possible emissions. Ignition and injection functions are electronically controlled, monitored and continually corrected during operation to maintain ideal air/fuel ratio.

Central component of system is Engine Control Unit (ECU) which manages system operation, determining best combination of fuel mixture and ignition timing for current operating conditions.

A lift fuel pump is used to move fuel from tank through an in-line fuel filter and fuel line. Fuel is then pumped to fuel pump module. Fuel pump module regulates fuel pressure to a system operating pressure of 39 psi. Fuel is delivered from fuel pump module through high pressure fuel line into injectors, which inject fuel into intake ports. ECU controls amount of fuel by varying length of time that injectors are on. This can range from 2 to over 12 milliseconds depending on fuel requirements. Controlled injection of fuel occurs every other crankshaft revolution, or once for each 4-stroke cycle. When intake valve opens, air/fuel mixture is drawn into combustion chamber, where it is compressed, ignited, and burned.

ECU controls amount of fuel being injected and ignition timing by monitoring primary sensor signals for engine temperature, speed (RPM), and throttle position (load). These primary signals are compared to preprogrammed maps in ECU computer chip, and ECU adjusts fuel delivery to match mapped values. After engine reaches operating temperature, an exhaust gas oxygen sensor provides feedback to ECU based upon amount of unused oxygen in exhaust, indicating whether fuel mixture being delivered is rich or lean. Based upon this feedback, ECU further adjusts fuel input to re-establish ideal air/fuel ratio. This operating mode is referred to as closed loop operation. EFI system operates closed loop when all three of following conditions are met:

- Engine temperature is greater than 45°C (113°F).
- Oxygen sensor has warmed sufficiently to provide a signal (minimum 400°C, 752°F).
- Engine operation is at a steady state (not starting, warming up, accelerating, etc.).

During closed loop operation ECU has ability to readjust temporary and learned adaptive controls, providing compensation for changes in overall engine condition and operating environment, so it will be able to maintain ideal air/fuel ratio. This system requires a minimum engine temperature of 50°-60°C (122°-140°F) to properly adapt. These adaptive values are maintained as long as ECU is not reset.

During certain operating periods such as cold starts, warm up, acceleration, high load, etc., a richer air/fuel ratio is required and system operates in an open loop mode. In open loop operation oxygen sensor output is used to ensure engine is running rich, and controlling adjustments are based on primary sensor signals and programmed maps only. This system operates open loop whenever three conditions for closed loop operation (above) are not being met.

ECU is brain or central processing computer of entire EFI system. During operation, sensors continuously gather data which is relayed through wiring harness to input circuits within ECU. Signals to ECU include: ignition (on/off), crankshaft position and speed (RPM), throttle position, engine temperature, intake air temperature, exhaust oxygen levels, manifold absolute pressure, and battery voltage.

EFI SYSTEM

ECU compares input signals to programmed maps in its memory to determine appropriate fuel and spark requirements for immediate operating conditions. ECU then sends output signals to set injector duration and ignition timing.

ECU continually performs a diagnostic check of itself, each of sensors, and system performance. If a fault is detected, ECU can turn on a Malfunction Indicator Light (MIL) (if equipped) on equipment control panel, store fault code in its fault memory, and go into a default operating mode. Depending on significance or severity of fault, normal operation may continue. A technician can access stored fault code using a blink code diagnosis flashed out through MIL. An optional computer software diagnostic program is also available, see Tools and Aids.

ECU requires a minimum of 6.0 volts to operate.

To prevent engine over-speed and possible failure, a rev-limiting feature is programmed into ECU. If maximum RPM limit (4500) is exceeded, ECU suppresses injection signals, cutting off fuel flow. This process repeats itself in rapid succession, limiting operation to preset maximum.

Wiring harness used in EFI system connects electrical components, providing current and ground paths for system to operate. All input and output signaling occurs through two special all weather connectors that attach and lock to ECU. Connectors are Black and Grey and keyed differently to prevent being attached to ECU incorrectly.

Condition of wiring, connectors, and terminal connections is essential to system function and performance. Corrosion, moisture, and poor connections are as likely cause of operating problems and system errors as an actual component. Refer to Electrical System for additional information.

EFI system is a 12 VDC negative ground system, designed to operate down to a minimum of 6.0 volts. If system voltage drops below this level, operation of voltage sensitive components such as ECU, fuel pump, ignition coils, and injectors will be intermittent or disrupted, causing erratic operation or hard starting. A fully charged, 12 volt battery with a minimum of 350 cold cranking amps is important in maintaining steady and reliable system operation. Battery condition and state of charge should always be checked first when troubleshooting an operational problem.

For systems with a retractable starter, a minimum battery of 12 volts, 4 amp hours is required.

Keep in mind that EFI-related problems are often caused by wiring harness or connections. Even small amounts of corrosion or oxidation on terminals can interfere with milliamp currents used in system operation.

Cleaning connectors and grounds will solve problems in many cases. In an emergency situation, simply disconnecting and reconnecting connectors may clean up contacts enough to restore operation, at least temporarily.

If a fault code indicates a problem with an electrical component, disconnect ECU connector and test for continuity between component connector terminals and corresponding terminals in ECU connector using an ohmmeter. Little or no resistance should be measured, indicating that wiring of that particular circuit is OK.

Crankshaft position sensor is essential to engine operation; constantly monitoring rotation and speed (RPM) of crankshaft. There are 23 consecutive teeth cast into flywheel. One tooth is missing and is used to reference crankshaft position for ECU.

During rotation, an AC voltage pulse is created within sensor for each passing tooth. ECU calculates engine speed from time interval between consecutive pulses. Gap from missing tooth creates an interrupted input signal, corresponding to specific crankshaft position near BDC for cylinder #1. This signal serves as a reference for control of ignition timing by ECU. Synchronization of inductive speed pickup and crankshaft position takes place during first two revolutions each time engine is started. Sensor must be properly connected at all times. If sensor becomes disconnected for any reason, engine will quit running.

Throttle position sensor (TPS) is used to indicate throttle plate angle to ECU. Since throttle (by way of governor) reacts to engine load, angle of throttle plate is directly related to load on engine.

Mounted on throttle body and operated directly off end of throttle shaft, TPS works as a potentiometer, varying voltage signal to ECU in direct correlation to angle of throttle plate. This signal, along with other sensor signals, is processed by ECU and compared to internal preprogrammed maps to determine required fuel and ignition settings for amount of load.

Correct position of TPS is established and set at factory. Do not loosen TPS or alter mounting position unless absolutely required by fault code diagnosis. If TPS is loosened or repositioned, appropriate TPS Learn Procedure must be performed to re-establish baseline relationship between ECU and TPS.

Engine temperature sensor is used by system to help determine fuel requirements for starting (a cold engine needs more fuel than one at or near operating temperature).

Mounted on crankcase behind fuel pump module baffle, it has a temperature-sensitive resistor that monitors surface temperature. Resistance changes with temperature, altering voltage sent to ECU. Using a table stored in its memory, ECU correlates voltage drop to a specific temperature. Using fuel delivery maps, ECU then knows how much fuel is required for starting/running at that temperature.

Temperature/Manifold Absolute Pressure (TMAP) sensor is an integrated sensor that checks both intake air temperature and manifold absolute pressure.

Intake Air Temperature control is a thermally sensitive resistor that exhibits a change in electrical resistance with a change in its temperature. When sensor is cold, resistance of sensor is high. As sensor warms up, resistance drops and voltage signal increases. From voltage signal, ECU can determine temperature of intake air.

Purpose of sensing air temperature is to help ECU calculate air density. Higher air temperature less dense air becomes. As air becomes less dense ECU knows that it needs to lessen fuel flow to achieve correct air/fuel ratio. If fuel ratio was not changed engine would become rich, possibly losing power and consuming more fuel.

Manifold Absolute Pressure check provides immediate manifold pressure information to ECU. TMAP sensor measures difference in pressure between outside atmosphere and vacuum level inside intake manifold and monitors pressure in manifold as primary means of detecting load. Data is used to calculate air density and determine engine's mass air flow rate, which in turn determines required ideal fueling. TMAP also stores instant barometric pressure reading when key is turned ON.

Oxygen sensor functions like a small battery, generating a voltage signal to ECU based upon difference in oxygen content between exhaust gas and ambient air.

Tip of sensor, protruding into exhaust gas, is hollow. Outer portion of tip is surrounded by exhaust gas, with inner portion exposed to ambient air. When oxygen concentration on one side of tip is different than that of other side, a voltage signal up to 1.0 volt is generated and sent to ECU. Voltage signal tells ECU if engine is straying from ideal fuel mixture, and ECU then adjusts injector pulse accordingly.

Oxygen sensor functions after being heated to a minimum of 400°C (752°F). A heater inside sensor heats electrode to optimum temperature in about 10 seconds. Oxygen sensor receives ground through wire, eliminating need for proper grounding through muffler. If problems indicate a bad oxygen sensor, check all connections and wire harness. Oxygen sensor can also be contaminated by leaded fuel, certain RTV and/or other silicone compounds, fuel injector cleaners, etc. Use only those products indicated as O2 Sensor Safe.

Fuel injectors mount into intake manifold, and high pressure fuel line attaches to them at top end. Replaceable O-rings on both ends of injector prevent external fuel leakage and also insulate it from heat and vibration. A special clip connects each injector to high pressure fuel line and holds it in place. O-rings and retaining clip must be replaced any time fuel injector is separated from its normal mounting position.

When key switch is on, fuel pump module will pressurize high pressure fuel line to 39 psi, and voltage is present at injector. At proper instant, ECU completes ground circuit, energizing injector. Valve needle in injector is opened electromagnetically, and pressure in high pressure fuel line forces fuel down through inside. Director plate at tip of injector contains a series of calibrated openings which directs fuel into manifold in a cone-shaped spray pattern.

Injectors have sequential fueling that open and close once every other crankshaft revolution. Amount of fuel injected is controlled by ECU and determined by length of time valve needle is held open, also referred to as injection duration or pulse width. Time injector is open (milliseconds) may vary in duration depending on speed and load requirements of engine.

A high-voltage, solid-state, battery ignition system is used with EFI system. ECU controls ignition output and timing through transistorized control of primary current delivered to coils. Based on input from crankshaft position sensor, ECU determines correct firing point for speed at which engine is running. At proper instant, it interrupts flow of primary current in coil, causing electromagnetic flux field to collapse. Flux collapse induces an instantaneous high voltage in coil secondary which is strong enough to bridge gap on spark plug. Each coil fires every other revolution.

EFI engines are equipped with either a 15 or 25 amp charging system to accommodate combined electrical demands of ignition system and specific application. Charging system troubleshooting information is provided in Electrical System.

An electric fuel pump module and a lift pump are used to transfer fuel in EFI system. Pumping action is created by oscillation of positive and negative pressures within crankcase through a hose. Internal check valves prevent fuel from going backward through pump. Fuel pump module receives fuel from lift pump, increases and regulates pressure for fuel injectors.

Fuel pump module is rated for a minimum output of 13.5 liters per hour and regulated at 270 kilopascals (39 psi).

When key switch is turned ON and all safety switch requirements are met, ECU activates fuel pump module for about six seconds (prime process), which pressurizes system for start-up. If key switch is not promptly turned to start position, engine fails to start, or engine is stopped with key switch ON (as in case of an accident), ECU switches off pump preventing continued delivery of fuel. In this situation, MIL will go on, but it will go back off after 4 cranking revolutions if system function is OK. Once engine is running, fuel pump remains on.

Precision components inside fuel pump module are not serviceable. DO NOT attempt to open fuel pump module. Damage to components will result and warranty will be void. Because fuel pump module is not serviceable, engines are equipped with a special 10-micron EFI fuel filter to prevent harmful contamination from entering module.

If there are two filters in system, one before lift pump will be a standard 51-75 micron filter, and one after lift pump will be special 10-micron filter. Be sure to use an approved 10-micron filter for replacement.

High pressure fuel line is an assembly of hoses, injector caps and a fuel connector to fuel pump module. High pressure fuel line feeds fuel to top of injectors through injector caps. Caps are fastened to intake manifold and injectors are locked into place. A small retaining clip provides a secondary lock.

EFI SYSTEM

High pressure fuel line is serviced as a complete assembly to prevent tampering and safety hazards. Components are not individually serviceable.

Vent hose assembly is intended to vent fuel vapor out of fuel pump module and direct fuel vapor into throttle body. All EFI engines are equipped with an engine mounted purge port in #1 cylinder valley baffle. This capped purge port can be used by OEM to vent fuel tanks or used in conjunction with a carbon canister kit for Tier III evaporative emissions compliance. Purge port connects to vent hose assembly and directs all fuel vapor into throttle body. If purge port remains unused, port must remain capped to prevent dirt from entering engine.

EFI engines have no carburetor, so throttle function (regulate incoming combustion airflow) is achieved with a throttle valve in a separate throttle body attached to intake manifold. Throttle body/intake manifold provides mounting for fuel injectors, throttle position sensor, TMAP sensor, high pressure fuel line, idle speed screw, and air cleaner assembly.

Idle speed is only adjustment that may be performed on EFI system. Standard idle speed setting for EFI engines is 1500 RPM, but certain applications might require a different setting. Check equipment manufacturer's recommendation.

For starting and warm up, ECU will adjust fuel and ignition timing, based upon ambient temperature, engine temperature, and loads present. In cold conditions, idle speed will probably be different than normal for a few moments. Under other conditions, idle speed may actually start lower than normal, but gradually increase to established setting as operation continues. Do not attempt to circumvent this warm up period, or readjust idle speed during this time. Engine must be completely warmed up, in closed loop operating mode for accurate idle adjustment.

IMPORTANT NOTES!

- Cleanliness is essential and must be maintained at all times when servicing or working on EFI system. Dirt, even in small quantities, can cause significant problems.
- Clean any joint or fitting with parts cleaning solvent before opening to prevent dirt from entering system.
- Always depressurize fuel system through fuel connector on fuel pump module before disconnecting or servicing any fuel system components.
- Never attempt to service any fuel system component while engine is running or ignition switch is ON.
- Do not use compressed air if system is open. Cover any parts removed and wrap any open joints with plastic if they will remain open for any length of time. New parts should be removed from their protective packaging just prior to installation.
- Avoid direct water or spray contact with system components.
- Do not disconnect or reconnect ECU wiring harness connector or any individual components with ignition on. This can send a damaging voltage spike through ECU.
- Do not allow battery cables to touch opposing terminals. When connecting battery cables attach positive (+) cable to positive (+) battery terminal first, followed by negative (-) cable to negative (-) battery terminal.
- Never start engine when cables are loose or poorly connected to battery terminals.
- Never disconnect battery while engine is running.
- Never use a quick battery charger to start engine.
- Do not charge battery with key switch ON.
- Always disconnect negative (-) battery cable before charging battery, and also unplug harness from ECU before performing any welding on equipment.

ELECTRICAL COMPONENTS

Electronic Control Unit (ECU)

Pinout of ECU

Black Connector Side	
Pin #	Function
1	Ignition Coil #1 Ground
2	Battery Ground
3	Diagnostic Communication Line
4	Speed Sensor input
5	Fuel Injector Output #1 Ground
6	Fuel Injector Output #2 Ground
7	Oxygen Sensor Heater
8	Intake Air Temperature (TMAP) sensor input
9	Fuel Pump Ground
10	Ground for TPS, TMAP, O2 and Engine Temperature Sensors
11	Manifold Absolute Pressure (TMAP) sensor input
12	Throttle Position Sensor (TPS) input
13	Speed Sensor Ground
14	Engine Temperature Sensor input
15	Ignition Switch (Switched +12V)
16	Power for TPS and TMAP Sensors (+5V)
17	Oxygen Sensor (O2) input
18	Battery Power (Permanent +12V)

Grey Connector Side	
Pin #	Description
1	Not Used
2	Not Used
3	Malfunction Indicator Light (MIL) Ground
4	Not Used
5	Not Used
6	Not Used
7	Not Used
8	Not Used
9	Battery Ground
10	Ignition Coil #2 Ground
11	Not Used
12	Not Used
13	Not Used
14	Safety Switch Ground
15	Not Used
16	ECU
17	Fuel Pump Control (+12V)
18	Not Used

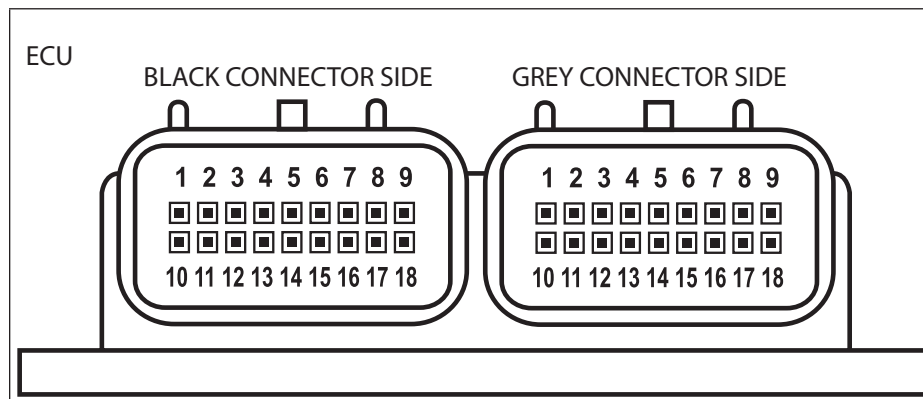

Pinout of ECU

EFI SYSTEM

Never attempt to disassemble ECU. It is sealed to prevent damage to internal components. Warranty is void if case is opened or tampered with in any way.

All operating and control functions within ECU are preset. No internal servicing or readjustment may be performed. If a problem is encountered, and you determine ECU to be faulty, contact your source of supply.

ECU pins and/or connectors are coated at factory with a thin layer of electrical grease to prevent fretting and corrosion. Do not attempt to remove grease from ECU pins and/or connectors.

Relationship between ECU and throttle position sensor (TPS) is very critical to proper system operation. If TPS or ECU is changed, or mounting position of TPS is altered, appropriate TPS Learn Procedure must be performed to restore synchronization.

Any service to ECU, TPS/Throttle Body (including idle speed increase over 300 RPM), or fuel pump module replacement should include ECU Reset.

This will clear all trouble codes, all closed loop learned offsets, all max values, and all timers besides permanent hour meter.

This system will NOT reset when battery is disconnected!

ECU Reset Procedure

1. Turn key/ignition OFF.
2. Install Red wire jumper from Rehlko EFI service kit on to service port (connect white wire to black wire in 4 way diagnostic port).
3. Turn key/ignition ON, then OFF and count 10 seconds.
4. Turn key/ignition ON, then OFF and count to 10 seconds a second time.
5. Remove Red wire jumper. Turn key/ignition ON, then OFF and count to 10 seconds a third time. ECU is reset.

A TPS Learn Procedure **must** be performed after ECU Reset.

TPS Learn Procedure

1. Turn idle screw clockwise one full turn prior to key/ignition ON after ECU Reset.
2. Start engine, run at low idle until engine is warm.
3. Idle speed must be above 1500 RPM. If below 1500 RPM, turn idle screw up to 1700 RPM and then shut down engine and perform ECU Reset again.
4. Restart engine, adjust idle speed down to 1500 RPM. Allow engine to dwell at 1500 RPM for about 3 seconds.
5. After this, adjust idle speed to final specified speed setting.
6. Turn key/ignition OFF and count to 10 seconds.

Learn procedure is complete.

Wiring Diagram

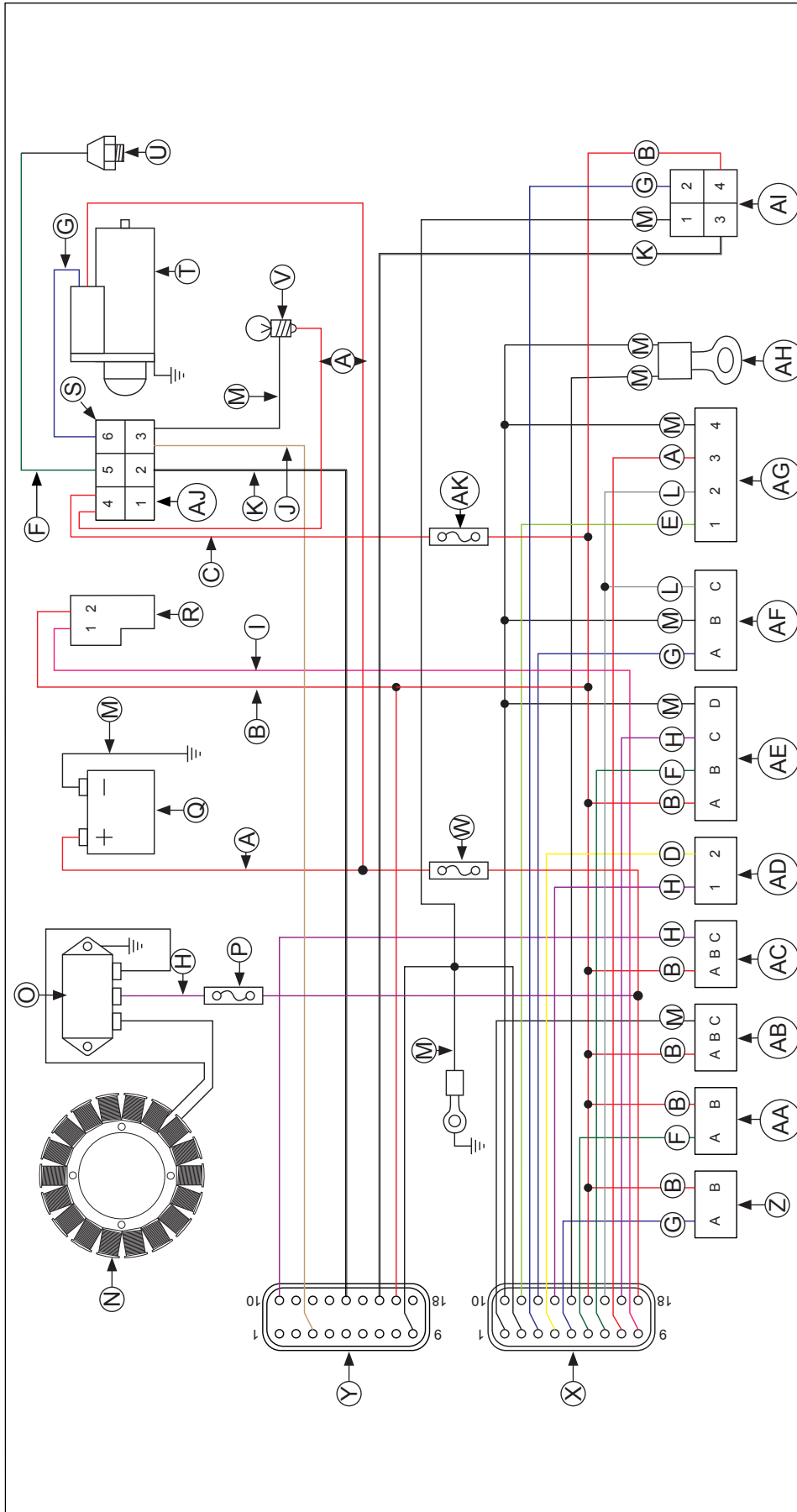

A	Red	Red/Black	C	Red/White	D	Yellow	E	Light Green
F	Dark Green	Dark Blue	H	Purple	I	Pink	J	Tan
K	White	Grey	M	Black	N	Stator	O	Rectifier-Regulator
P	30A Fuse (Charging System)	Battery	R	Fuel Pump	S	6-Terminal Connector	T	Starter Motor
U	Oil Pressure Switch	MIL	W	10A Fuse (Battery Power)	X	Black Connector	Y	Grey Connector
Z	Fuel Injector #1	Fuel Injector #2	AB	Ignition Coil #1	AC	Ignition Coil #2	AD	Crankshaft Position Sensor
AE	Oxygen Sensor	Throttle Position Sensor	AG	TMAP Sensor	AH	Engine Temperature Sensor	AI	Diagnostic Connector
AJ	Temperature Sensor (some models)	10A Fuse (Ignition Switch)						

EFI SYSTEM

Crankshaft Position Sensor

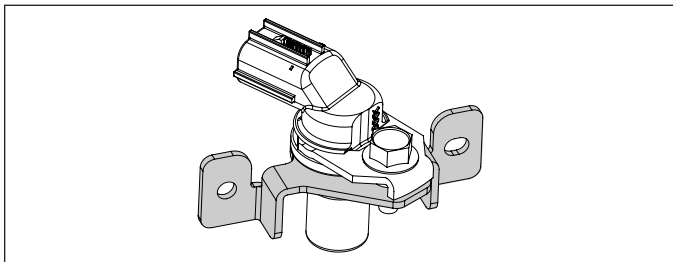

A sealed, non-serviceable assembly. If Fault Code diagnosis indicates a problem within this area, test and correct as follows.

1. Inspect wiring and connections for damage or problems.
2. Make sure engine has resistor type spark plugs.
3. Disconnect Black connector from ECU.
4. Connect an ohmmeter between #4 and #13 pin terminals. A resistance value of 325-395 Ω at room temperature (20°C, 68°F) should be obtained.
5. If resistance is incorrect, remove blower housing.
6. Disconnect crankshaft position sensor connector from wiring harness. Test resistance between terminals. A reading of 325-395 Ω should again be obtained.
 - a. If resistance is incorrect, remove screw securing sensor to crankcase and replace sensor.
 - b. If resistance in step 4 was incorrect, but resistance of sensor alone was correct, test wire harness circuits between sensor connector terminals and corresponding pin terminals (#4 and #13) in main connector. Correct any observed problem, reconnect sensor, and perform step 4 again.
7. If resistance is correct from step 4, check mounting, flywheel teeth (damage, run-out, etc.), and flywheel key.
8. When fault is corrected and engine starts, clear fault codes following ECU Reset procedure.

Throttle Position Sensor (TPS)

TPS is a sealed, non-serviceable assembly. If diagnosis indicates a bad sensor, complete replacement is necessary. A magnet that sensor detects is separate, and can be replaced or reused. If a blink code indicates a problem with TPS, it can be tested as follows:

Diagnostics of sensor: ECU will have electrical faults captured in fault codes P0122 and P0123. Fault code P0122 detecting low voltage, open circuit, and P0123 for high voltage conditions between ECU, wire harness, and sensor. Tip: when working with any electrical connection, remember to keep connections clean & dry. This is best accomplished by cleaning connection thoroughly prior to disassembly. Contaminated sensor connections can cause premature engine faults. Functionally testing sensor can no longer be done with simple resistance checks. If either of these two faults is present or a TPS fault is suspected, recommended diagnostic test is as follows:

If a computer with diagnostic software is available

Observe throttle percent and raw TPS values through diagnostic software. With diagnostic software communicating to ECU and key ON engine not running, these values can be observed while throttle is moved from closed to full open position. There should be a smooth and repeatable throttle percent value starting at closed position reading between 0 (about 6.5%) to WOT position reading 93 (100%). If one of these values is outside of specified range and output transitions in a smooth manner, reset ECU and run test again. Since there are no longer any wear elements inside sensor, most likely faults will be in electrical connections between sensor and wire harness and wire harness to ECU. With service software communicating to ECU and engine not running, a small load or gentle back and forth motion can be applied to connectors or wires just outside connectors to detect a faulty connection.

If only a volt meter is available

Measure voltage supply to sensor from ECU. This voltage should be 5.00 +/- 0.20 volts. This can be measured by gently probing terminals B & C on harness side with TPS connector removed from TPS and key ON. This will generate a P0122 fault that can be cleared with an ECU reset. If voltage is low, battery, harness and ECU should be investigated. If supply voltage is good, plug sensor back into harness. Probe sensor signal wire with volt meter, terminal A at TPS or pin Black 12 at ECU. This signal should start between 0.6-1.2 volts at low idle and grow smoothly as throttle is opened to 4.3-4.8 volts at full open (WOT). Since there are no longer any wear elements inside sensor, most likely faults will be in electrical connections between sensor and wire harness and wire harness to ECU.

Replace magnet assembly

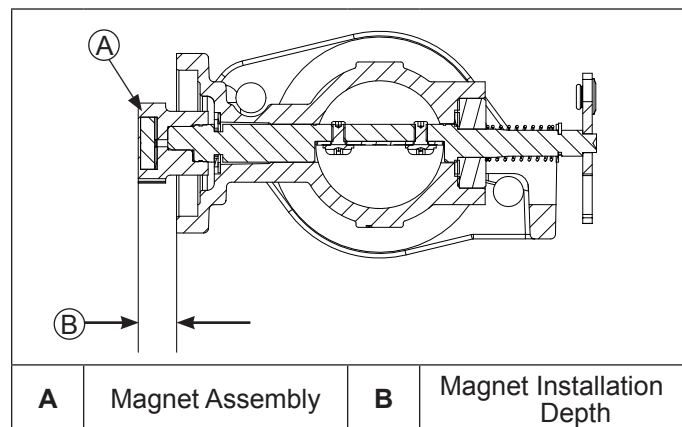

Magnet assembly is captured in a small plastic housing that is press fit to end of throttle shaft. This generally does not need replacement. If replacement is required, it can be replaced as follows:

1. Remove sensor from throttle body, exposing round magnet assembly.

2. A pair of flat blade screw drivers or a spanner tool can be used to pry this off shaft. Caution should be used to avoid damage to machined flat surface that sensor seals against. Also, make sure throttle blade is in full open position to avoid driving throttle blade into throttle bore causing damage to blade and/or bore.
3. When replacing magnet assembly, alignment is critical. There is a D-shaped drive feature on end of shaft and a matching pocket in magnet assembly. On outer diameter of magnet assembly is a notch that aligns with center of flat feature of D. Align this notch and flat of D feature in shaft and preassemble parts.
4. With throttle blade in full open position (WOT), press magnet assembly fully on to throttle shaft. Full insertion can be checked by measuring height from throttle body sensor mounting face to end of magnet assembly. This should be no more than 8.6 mm (0.338 in.). Installation process requires significant force, so take care that all parts are aligned. Tapping magnet assembly on can fracture/damage brittle magnet within assembly and throttle body assembly and is NOT RECOMMENDED.

Engine Temperature Sensor

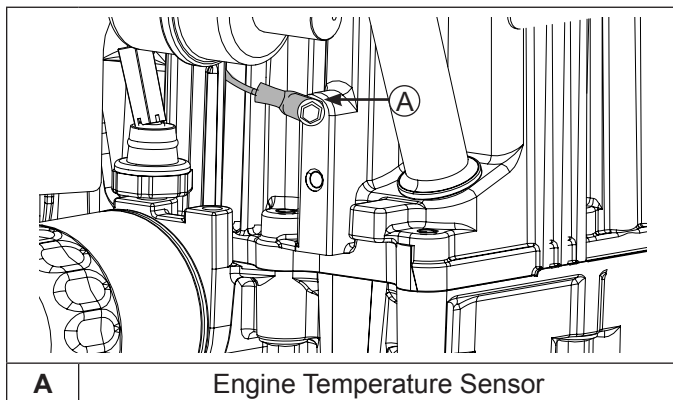

NOTE: Engine temperature sensor resembles a ground wire.

A sealed, non-serviceable assembly. A faulty sensor requires a wire harness replacement. If a blink code indicates a problem with temperature sensor, it can be tested as follows:

1. Shut off engine and allow it to return to room temperature (25°C, 77°F).
2. With sensor still connected, check temperature sensor circuit resistance between Black pin 10 and 14 terminals. Value should be 9000-11000 Ω.
3. If resistance is out of specifications, replace wire harness.

Temperature/Manifold Absolute Pressure (TMAP) Sensor

A sealed non-serviceable integrated sensor that checks both intake air temperature and manifold absolute pressure. Complete replacement is required if it is faulty. Sensor and wiring harness can be checked as follows.

If a blink code indicates a problem with Intake Air Temperature (TMAP) Sensor Circuit (P0112 or P0113), it can be tested as follows:

1. Remove TMAP sensor from intake manifold.
2. Allow it to reach room temperature (20°C, 68°F).
3. Unplug Black connector from ECU.
4. With sensor still connected, check temperature sensor circuit resistance between Black pins 10 and 8. Value should be 1850-2450 Ω.
5. Unplug sensor from wire harness and check sensor resistance separately across pins. Resistance value should again be 1850-2450 Ω.
 - a. If resistance is out of specifications, check local temperature. Sensor resistance will go down as temperature is higher. Replace TMAP sensor if determined to be faulty.
 - b. If it is within specifications, proceed to Step 6.
6. Check circuits (input, ground), from main harness connector to sensor plug for continuity, damage, etc. Connect one ohmmeter lead to Black pin 8 in main harness connector (as in step 4). Connect other lead to terminal #3 in sensor plug. Continuity should be indicated. Repeat test between Black pin 10 and terminal #4 in sensor plug.
7. Reinstall sensor.

If a blink code indicates a problem with Manifold Absolute Pressure (TMAP) Sensor Circuit (P0107 or P0108), it can be tested as follows:

1. Make sure all connections are making proper contact and are free of dirt and debris. Slide locking tab out and pull off TMAP connector. Turn key switch to ON and check with a volt meter by contacting red lead to pin 1 and black lead to pin 2. There should be 5 volts present, indicating ECU and wiring harness are functioning.
2. Check continuity in wire harness. Ohms between Pin 3 at sensor connector and Black pin 11 connector at ECU should be near zero ohms. If no continuity is measured or very high resistance, replace wire harness.
3. Check to make sure intake manifold is not loose and TMAP sensor is not loose. Loose parts would allow a vacuum leak, making TMAP sensor report misleading information to ECU.
 - a. Tighten all hardware and perform an ECU Reset and a TPS Learn Procedure to see if MIL will display a fault with sensor again. If MIL finds a fault with TMAP sensor, replace it.

EFI SYSTEM

Oxygen Sensor (O₂)

Components

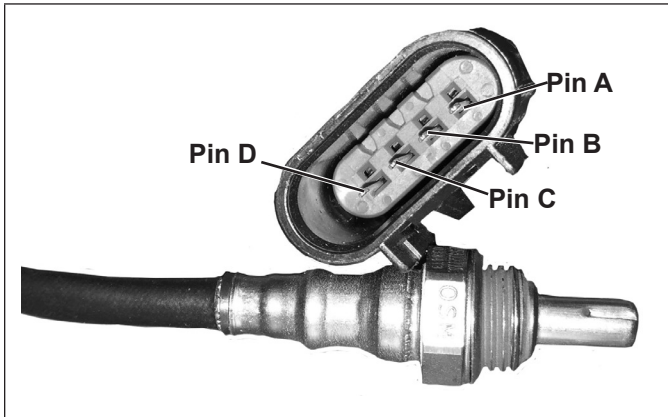

Cutaway Oxygen Sensor Components (O₂)

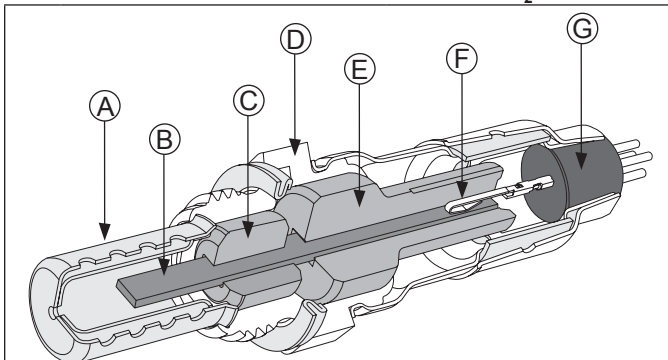

A	Protection Shield	B	Planar Element and Heater
C	Lower Insulator	D	Stainless Steel Housing
E	Upper Insulator	F	Terminal Connection to Element
G	High Temp Water Seal		

Temperature must be controlled very accurately and gas constituents measured to a high degree of accuracy for absolute sensor measurements. This requires laboratory equipment to determine a good or bad sensor in field. Furthermore, as with most devices, intermittent problems are difficult to diagnose. Still, with a good understanding of system and sensor, it is possible to diagnose many sensor problems in field.

Using diagnostic software connected to ECU is a useful technique for observing sensor performance. However, user must understand that such software reads a signal generated by ECU. If there is an ECU or wiring problem, readings could be misinterpreted as a sensor problem. Digital nature of signal to software means that it is not reading continuous output of sensor. A voltmeter can also be used as an effective tool in diagnosing sensors. It is advisable to use an electronic meter such as a digital voltmeter. Simple mechanical meters may place a heavy electrical load on sensor and cause inaccurate readings. Since resistance of sensor is highest at low temperatures, such meters will cause largest inaccuracies when sensor is in a cool exhaust.

Visual Inspection

1. Look for a damaged or disconnected sensor-to-engine harness connection.
2. Look for damage to sensor lead wire or associated engine wiring due to cutting, chaffing or melting on a hot surface.
3. Disconnect sensor connector and look for corrosion in connector.
4. Try reconnecting sensor and observe if problem has cleared.
5. Correct any problems found during visual check.

Sensor Signal Observation

NOTE: Do not cut into or pierce sensor or engine wiring to make this connection. Sensor produces a very small signal. Corrosion or damage to wiring could lead to an incorrect signal because of repairs or contamination to sensor.

1. Using a voltmeter or diagnostic software observe voltage before engine is started. With key ON, voltage should read about 1.0 volt. This voltage is generated by ECU. If it is not present, disconnect sensor and observe voltage at harness connector. If voltage is now present, there is a short in sensor or associated wiring and corrective action should be taken. If voltage still is not present, there is a problem with ECU or engine harness.
2. Reconnect sensor and start engine. Run engine at sufficient speed to bring sensor up to operating temperature. Maintain for 1 to 2 minutes to ensure that engine has gone closed loop. Once in closed loop, sensor voltage should cycle between about 100 to 250 mv and 700 to 900 mv. If this cycling is not observed, a determination must be made, if problem is with engine or sensor.
3. Check engine harness for battery voltage on heater circuit.

Removal Inspection

NOTE: Apply anti-seize compound only to threads. Anti-seize compound will affect sensor performance if it gets into lower shield of sensor.

1. If sensor has heavy deposits on lower shield, engine, oil, or fuel may be source.
2. If heavy carbon deposits are observed, incorrect engine fuel control may be occurring.
3. If sensor is at room temperature, measure between signal leads, black wire (Pin C) and grey wire (Pin D) attached to sensor. If resistance is less than one megohm, sensor has an internal short.
4. With sensor at room temperature measure heater circuit resistance, purple wire (Pin A) and white wire (Pin B), resistance should be 8.1-11.1 Ω .
5. If a damaged sensor is found, identify root cause, which may be elsewhere in application. Refer to Troubleshooting-Oxygen Sensor (O₂) table.

6. A special "dry to touch" anti-seize compound is applied to all new oxygen sensors at factory. If recommended mounting thread sizes are used, this material provides excellent anti-seize capabilities and no additional anti-seize is needed. If sensor is removed from engine and reinstalled, anti-seize compound should be reapplied. Use an oxygen sensor safe type anti-seize compound. It should be applied according to directions on label.

Troubleshooting-Oxygen Sensor (O₂)

Condition	Possible Cause	Conclusion
Low voltage output.	Shorted sensor or sensor circuit. Shorted lead wire. Wiring shorted to ground.	Replace sensor or repair wiring.
	Contamination of air reference.	Remove source of external contamination, protect air reference area.
	Air leak at sensor or gasket, sensor upper shield damage.	Use recommended torque at installation, replace gasket or sensor. Revise application exhaust. Shield sensor from damage.
High voltage output.	Silica poisoning.	Replace sensor.
	Contaminated gasoline.	Use high quality fuel.
	Engine problem; misfire.	Correct cause of misfire.
	Excessive rich air/fuel ratio.	Check for high fuel pressure Leaking injector Liquid fuel in vent line
	Wiring shorted to voltage.	Repair wiring.
Open circuit, no activity from sensor.	Broken element. Sensor dropped. Hard blow to engine or exhaust system. Defective sensor. Thermal shock.	Replace sensor.
Slow time response.	Open heater circuit. Improper handling. Carbon deposits.	Replace sensor.
	Improper fueling.	Correct fueling.
	Incorrect or contaminated fuel.	Use high quality fuel.
	Excessive engine oil consumption causing exhaust contamination or other exhaust side contamination.	Correct engine condition.
	Heater circuit open/shorted or out of specification.	Repair short in harness wires, replace sensor.

EFI SYSTEM

Fuel Injectors

	⚠ WARNING
	Explosive Fuel can cause fires and severe burns. Fuel system ALWAYS remains under HIGH PRESSURE.
Wrap a shop towel completely around fuel pump module connector. Press release button(s) and slowly pull connector away from fuel pump module allowing shop towel to absorb any residual fuel in high pressure fuel line. Any spilled fuel must be completely wiped up immediately.	

Details

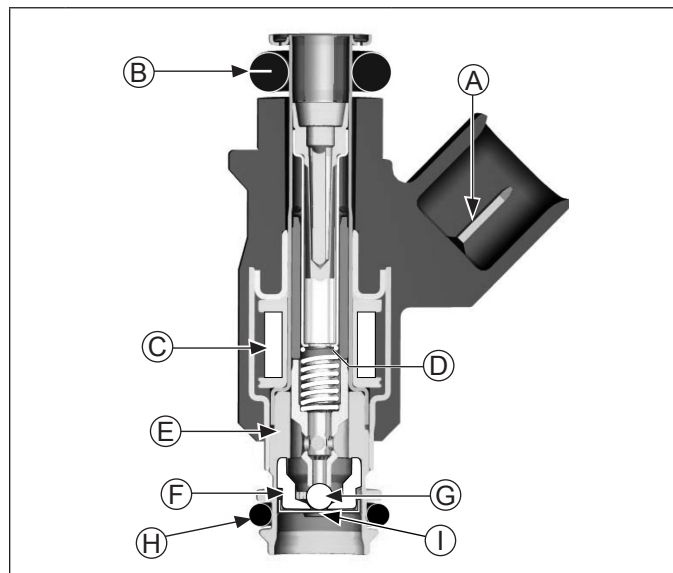

A	Electrical Connection	B	Upper O-ring
C	Solenoid Winding	D	Armature
E	Valve Housing	F	Valve Seat
G	Valve End	H	Lower O-ring
I	Director Plate		

NOTE: Do not apply voltage to fuel injector(s). Excessive voltage will burn out injector(s). Do not ground injector(s) with ignition ON. Injector(s) will open/turn on if system is energized.

NOTE: When cranking engine with injectors disconnected, fault codes will be registered in ECU and will need to be cleared using software fault clear or an ECU Reset and TPS Learn Procedure.

Injector problems typically fall into three general categories: electrical, leakage, or dirty/clogged. An electrical problem usually causes one or both of injectors to stop functioning. Several methods may be used to check if injectors are operating.

1. With engine running at idle, listen for a buzzing or clicking sound.
2. Disconnect electrical connector from an injector and listen for a change in idle performance (only running on one cylinder) or a change in injector noise or vibration.

If an injector is not operating, it can indicate either a bad injector, or a wiring/electrical connection problem. Check as follows:

1. Disconnect electrical connector from both injectors. Plug a 12 volt noid light into one connector.
2. Make sure all safety switch requirements are met. Crank engine and check for flashing of noid light. Turn key OFF for at least 10 seconds between tests to allow ECU to go to sleep and reawake. Repeat test at other connector.
 - a. If flashing of noid light occurs, use an ohmmeter (Rx1 scale) and check resistance of each injector across two terminals. Proper resistance is 11-13 Ω . If injector resistance is incorrect, replace injector.

If injector resistance is correct, visually inspect connection between connector and injector terminals. Terminals should be free of corrosion, wear, or dirt. If a problem is found, clean/repair/replace as needed.

- b. If no noid light flashing occurs, reattach connectors to both injectors. Disconnect black connector from ECU. Use an ohmmeter (Rx1 scale) and check injector circuit resistance between black pins 5 and 15 for injector #1, and pins 6 and 15 for injector #2. Proper resistance should be 11-13 Ω for each. If circuit resistance is incorrect, check all electrical connections, connectors, and wiring harness leads for issues.

If circuit resistance is found to be correct, injector circuit is inactive (no noid light operation) due to other problems within system. Test and inspect for proper system operating voltage and appropriate grounds. Correct or repair any problem found.

Injector leakage is very unlikely, but in those rare instances it can be internal (past tip of valve needle), or external (weeping around injector O-rings). Loss of system pressure from leakage can cause hot restart problems and longer cranking times. Refer to Disassembly for removal of injector.

1. Remove manifold mounting bolts and separate throttle body/manifold from engine leaving TPS, high pressure fuel line, injectors and fuel line connections intact. Discard old gaskets.
2. Position manifold assembly over an appropriate container to capture fuel and turn key switch ON to activate fuel pump and pressurize system. Do not turn switch to START position.

NOTE: Fuel pump module pins are coated with a thin layer of electrical grease to prevent fretting and corrosion. Do not attempt to remove electrical grease from fuel pump module pins.

3. If either injector exhibits leakage of more than two to four drops per minute from tip, or shows any sign of leakage around outer shell, turn ignition switch OFF and replace injector as follows.
4. Depressurize fuel system.

5. Clean any dirt accumulation from sealing/mounting area of faulty injector(s) and disconnect electrical connector(s).
6. Pull retaining clip off top of injector(s). Remove screw holding injector(s) from manifold.
7. Reverse appropriate procedures to install new injector(s) and reassemble engine. Use new O-rings and retaining clips any time an injector is removed (new replacement injectors include new O-rings and retaining clips). Lubricate O-rings lightly with clean engine oil. Use installation tool provided with O-rings to install new upper O-ring. Place tool into fuel injector inlet. Place one side of O-ring into O-ring groove and roll O-ring over tool onto fuel injector. Torque screw securing fuel injector caps to 7.3 N·m (65 in. lb.). An ECU Reset and TPS Learn Procedure will need to be completed.

Injector problems due to dirt or clogging are generally unlikely due to design of injectors, high fuel pressure, and detergent additives in gasoline.

Symptoms that could be caused by dirty/clogged injectors include rough idle, hesitation/stumbling during acceleration, or triggering of fault codes related to fuel delivery. Injector clogging is usually caused by a buildup of deposits on director plate, restricting flow of fuel, resulting in a poor spray pattern. Some contributing factors to injector clogging include higher than normal operating temperatures, short operating intervals, and dirty, incorrect, or poor quality fuel. Cleaning of clogged injectors is not recommended; they should be replaced. Additives and higher grades of fuel can be used as a preventative measure if clogging has been a problem.

Ignition Coils

If a coil is determined to be faulty, replacement is necessary. Refer to Electronic Ignition System tests and Spark Testing before performing electrical tests below. An ohmmeter may be used to test wiring and coil windings.

NOTE: Do not ground primary coil with ignition ON as they may overheat or spark.

NOTE: Always disconnect spark plug lead from spark plug before performing following tests.

NOTE: **If ignition coil(s) are disabled and an ignition fault is registered, system will automatically disable corresponding fuel injector drive signal.** Fault must be corrected to ignition coil and ECU power (switch) must be turned OFF for 10 seconds for injector signal to return. This is a safety measure to prevent bore washing and oil dilution.

Testing

Main purpose of performing ignition coil resistance test is to identify if primary (low voltage) and secondary (high voltage) circuits are shorted to each other or ground. Coil resistance readings will vary based on temperature. If coil passes spark testing, and primary and secondary circuits are not shorted, resistance variations outside specified range may be normal due to temperature.

Using an ohmmeter set on Rx1 scale, check resistance in circuits as follows:

1. To check cylinder coil 1 (starter side), disconnect Black connector from ECU and test between Black pins 1 and 15. To check cylinder coil 2 (oil filter side), disconnect Grey connector from ECU and test between Grey pins 10 and 17. Wiring and coil primary circuits are OK if readings are 0.5-0.8 Ω.
2. If reading(s) are not within specified range, check and clean connections and retest.
3. If reading(s) are still not within specified range, test coils separately from main harness as follows:
 - a. Remove screw retaining coil to housing and disconnect primary leads connector.
 - b. Connect an ohmmeter set on Rx1 scale to primary terminals of coil. Primary resistance should be 0.5-0.8 Ω.
 - c. Connect an ohmmeter set on Rx10K scale between spark plug boot terminal and B+ primary terminal. Secondary resistance should be 6400-7800 Ω.
 - d. If secondary resistance is not within specified range, coil is faulty and needs to be replaced.

FUEL COMPONENTS

	▲ WARNING
	Explosive Fuel can cause fires and severe burns. Fuel system ALWAYS remains under HIGH PRESSURE.
Wrap a shop towel completely around fuel pump module connector. Press release button(s) and slowly pull connector away from fuel pump module allowing shop towel to absorb any residual fuel in high pressure fuel line. Any spilled fuel must be completely wiped up immediately.	

Fuel Pump Module (FPM)

FPM is not serviceable and must be replaced if determined to be faulty. If a FPM problem is suspected, make certain pump is being activated, all electrical connections are properly secured and fuses are good. If required, testing of FPM may be conducted.

1. Relieve fuel pressure at FPM. FPM may need to be loosened or pulled away from engine. Press release button(s) and slowly pull connector away from FPM allowing shop towel to absorb any residual fuel in high pressure fuel line. Insert pressure test jumper (from Rehiko EFI Service Kit) between high pressure fuel line and FPM.
2. Connect black hose of Pressure Tester. Route clear hose into a portable gasoline container or equipment fuel tank.
3. Turn on key switch to activate pump and check system pressure on gauge. It may take several key cycles to compress air introduced into system and reach regulated pressure. System pressure of 39 psi ± 3 should be present. Turn key switch OFF and depress valve button on tester to relieve system pressure.
 - a. If pressure is too high or too low, proceed to troubleshooting.

EFI SYSTEM

4. If pump did not activate (step 3), confirm that safety system on equipment is not active. One potential cause of unnecessary FPM replacement may involve measuring voltage at FPM electrical connector. Using a Digital Volt Ohm Meter (DVOM) will provide a reading near battery voltage, even when ECU is not grounding FPM circuit.
 - a. Connect a DVOM across terminals in plug, turn on key switch and confirm battery voltage is present during six second prime process.
 - b. Test light confirmation: Turn key off. Disconnect DVOM. Connect 12 volt test light across terminals in plug. Key needs to remain off for a minimum of 30 seconds before proceeding. Turn key on. Confirm test light illuminates for approximately 6 seconds. After approximately 6 seconds, test light will remain off unless another prime cycle is initiated.
5. If battery voltage is not present and/or test light does not illuminate, connect red lead of DVOM to red wire of plug and black lead to a battery ground while key is still ON.
6. If battery voltage is present, turn key switch OFF and connect an ohmmeter between terminals on FPM to check for continuity. If battery voltage at plug was confirmed, and there was continuity across FPM terminals, reconnect plug to FPM, making sure you have a good connection. Turn on key switch and listen for FPM to activate.
 - a. If FPM starts, repeat steps 2 and 3 to verify correct pressure.
 - b. If FPM still does not operate, replace it.
7. If battery voltage was not present at connector inspect fuse and wiring harness.

High Pressure Fuel Line

High pressure fuel line is mounted to intake manifold. No specific servicing is required unless operating conditions indicate that it needs replacement. Thoroughly clean area around all joints and relieve any pressure before starting any disassembly. Detach by removing two mounting screws, wire ties, and injector retaining clips.

Purge Port and Vent Hose Assembly

No specific servicing is required for vent hose assembly or purge port unless operating conditions indicate replacement is required. All components are serviced individually. Abrasion sleeves on hoses should be reused or replaced when servicing vent hoses. Please note vent hose routing and replicate after service or component replacement to prevent pinching or abrasion of vent hoses. Only Rehiko replacement parts can be used because fitting is specific to system and must be maintained. Visit Engines.rehiko.com for recommended Rehiko replacement parts.

Throttle Body/Intake Manifold Assembly

NOTE: ECU Reset is required if throttle body is replaced.

Throttle body is serviced as an assembly, with throttle shaft, TPS, throttle plate, and idle speed adjusting screw installed. Throttle shaft rotates on needle bearings (non-serviceable), capped with seals to prevent air leaks.

TROUBLESHOOTING

Troubleshooting Guide

Condition	Possible Cause
Engine Starts Hard or Fails to Start When Cold.	Fuel pump not running.
	Faulty spark plugs.
	Old/stale fuel.
	Incorrect fuel pressure.
	Crankshaft position sensor loose or faulty.
	TPS set incorrect (ECU Reset and TPS Learn).
	TPS faulty.
	Engine temp sensor faulty.
	Faulty coils.
	Low system voltage.
	Faulty injectors.
	Faulty battery.
	Loose or corroded connections.

Troubleshooting Guide

Condition	Possible Cause
Engine Starts Hard or Fails to Start When Hot.	Faulty spark plugs.
	Fuel pump not running.
	Fuel pressure low.
	Insufficient fuel delivery.
	TPS set incorrect (ECU Reset and TPS Initialization).
	Crankshaft position sensor loose or faulty.
	TPS faulty.
	Engine temp sensor faulty.
Engine Stalls or Idles Roughly (cold or warm).	Faulty spark plugs.
	Insufficient fuel delivery.
	TPS set incorrect.
	TPS faulty.
	Faulty engine temperature sensor.
Engine Misses, Hesitates, or Stalls Under Load.	Fuel injector(s), fuel filter, fuel line, or fuel pick-up dirty/restricted.
	Dirty air cleaner.
	Insufficient fuel pressure or fuel delivery.
	Vacuum (intake air) leak.
	Improper governor setting, adjustment or operation.
	TPS faulty, mounting problem or TPS Initialization Procedure incorrect.
	Bad coil(s), spark plug(s), or wires.
Low Power	Faulty/malfunctioning ignition system.
	Dirty air filter.
	Insufficient fuel delivery.
	Improper governor adjustment.
	Plugged/restricted exhaust.
	One injector not working.
	Basic engine problem exists.
	TPS faulty or mounting problem. Throttle plate in throttle body not fully opening to WOT stop (if equipped).

EFI SYSTEM

Function Test

	⚠ WARNING
	<p>High Pressure Fluids can puncture skin and cause severe injury or death.</p> <p>Do not work on fuel system without proper training or safety equipment.</p>
<p>Fluid puncture injuries are highly toxic and hazardous. If an injury occurs, seek immediate medical attention.</p>	

Function of fuel system is to provide sufficient delivery of fuel at system operating pressure of 39 psi ± 3. If an engine starts hard, or turns over but will not start, it may indicate a problem with EFI fuel system. A quick test will verify if system is operating.

1. Disconnect and ground spark plug leads.
2. Complete all safety interlock requirements and crank engine for approximately 3 seconds.
3. Remove spark plugs and check for fuel at tips.
 - a. If there is fuel at tips of spark plugs fuel pump and injectors are operating.
 - b. If there is no fuel at tips of spark plugs, check following:
 1. Make sure fuel tank contains clean, fresh, proper fuel.
 2. Make sure that vent in fuel tank is open.
 3. Make sure fuel tank valve (if equipped) is fully opened.
 4. Make sure battery is supplying proper voltage.
 5. Check that fuses are good, and that no electrical or fuel line connections are damaged or broken.
 6. Test fuel pump module operation as described earlier under Fuel Pump Module (FPM).

Fault Codes

Example of Diagnostic Display

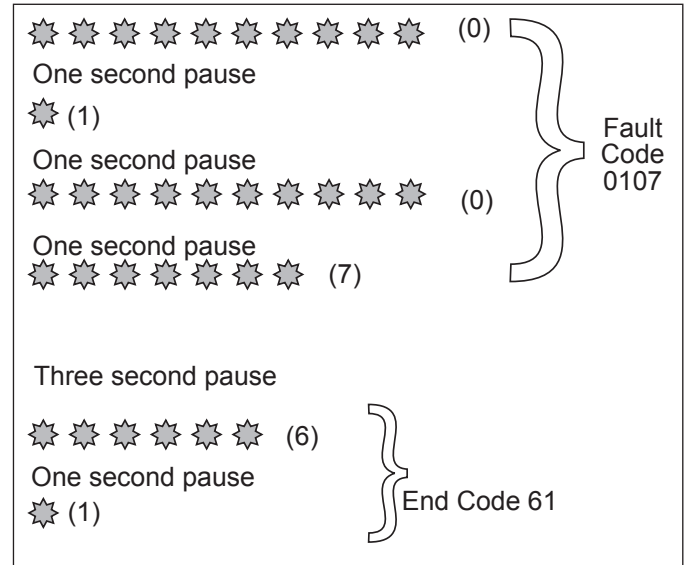

Diagnostic Fault Code Summary

Fault Code	Connection or Failure Description
0031	Oxygen Sensor Heater Circuit Low Voltage
0032	Oxygen Sensor Heater Circuit High Voltage
0107	Manifold Absolute Pressure (TMAP) Circuit Low Voltage or Open
0108	Manifold Absolute Pressure (TMAP) Circuit High Voltage
0112	Intake Air Temperature (TMAP) Circuit Low Voltage
0113	Intake Air Temperature (TMAP) Circuit High Voltage or Open
0117	Engine Temperature Sensor Circuit Low Voltage
0118	Engine Temperature Sensor Circuit High Voltage or Open
0122	Throttle Position Sensor Circuit Low Voltage or Open
0123	Throttle Position Sensor Circuit High Voltage
0131	Oxygen Sensor 1 Circuit Low Voltage, or Open
0132	Oxygen Sensor 1 Circuit High Voltage
0171	Maximum Adaptation Limit Exceeded
0172	Minimum Adaptation Limit Exceeded
0174	Lean Fuel Condition at High Load (Open Loop)
0201	Injector 1 Circuit Malfunction
0202	Injector 2 Circuit Malfunction

0217	Engine Overtemperature Condition
0230	Fuel Pump Module Circuit Low Voltage or Open
0232	Fuel Pump Module Circuit High Voltage
0336	Crankshaft Position Sensor Noisy Signal
0337	Crankshaft Position Sensor No Signal
0351	Cylinder 1 Ignition Coil Malfunction
0352	Cylinder 2 Ignition Coil Malfunction
0562	System Voltage Low
0563	System Voltage High
61	End of Code Transmission

ECU continuously monitors engine operation against preset performance limits. If operation is outside limits, ECU activates MIL, if equipped, and stores a diagnostic code in its fault memory. If component or system returns to proper function, ECU will turn off MIL. If MIL stays illuminated, it warns customer a fault is currently happening, and dealer service is required. Upon receipt, dealer technician can access fault code(s) to help determine what portion of system is malfunctioning.

Codes are accessed through key switch and displayed as blinks or flashes of MIL. Access codes as follows:

1. Check that battery voltage is above 11 volts.
2. Start with key switch OFF.
3. Turn key switch to ON and OFF, then ON and OFF, then ON, leaving it on in third sequence. Do not start engine. Time between sequences must be less than 2.5 seconds.
4. MIL will blink a series of times. Number of times MIL blinks represents a number in blink code.
5. A sequence of four digits make up a fault code. There is a one (1) second pause between blinks of a fault code. There is a three (3) second pause between separate fault codes. After fault code(s) are blinked a two digit 61 is blinked to indicate program has completed.
 - a. It's a good idea to write down codes as they appear, as they may not be in numerical sequence.
 - b. Code 61 will always be last code displayed, indicating end of code transmission. If code 61 appears immediately, no other fault codes are present.

After problem has been corrected, fault codes may be cleared by following ECU Reset and TPS Learn Procedures.

Diagnostic Fault Code Summary lists fault codes, and what they correspond to. Diagnostic Code Summary is a list of individual codes with an explanation of what triggers them, what symptoms might be expected, and probable causes.

A MIL may not be provided with engine. If equipment manufacturer has not added a MIL to equipment, one can be added easily for quick diagnostics. Main engine to vehicle connection will have a tan wire which is ground for MIL. Either incandescent or LED type bulbs can be used for MIL as long as they do not draw more than 0.1 amps. Bulb needs to be rated at 1.4 Watts or less, or needs to have a total resistance of 140 Ω or more. LEDs typically draw less than 0.03 amps. Attach +12 volts to positive terminal of bulb and attach ground terminal of bulb to tan wire.

Diagnostic Code Summary

Code 0031

Component:	Oxygen Sensor Heater
Fault:	O2S Heater Circuit Low Voltage
Condition:	System voltage too low, open connection or faulty sensor.
Conclusion:	<p>Engine Wiring Harness Related</p> <ul style="list-style-type: none"> ● Pin circuit wiring or connectors. ECU black pin 7 or broken wire. <p>Oxygen Sensor Related</p> <ul style="list-style-type: none"> ● Sensor connector or wiring problem. <p>Poor system ground from ECU to engine or battery to engine.</p>

Code 0032

Component:	Oxygen Sensor Heater
Fault:	O2S Heater Circuit High Voltage
Condition:	System voltage too high, shorted connection or faulty sensor.
Conclusion:	<p>Oxygen Sensor Related</p> <ul style="list-style-type: none"> ● Sensor connector or wiring problem. ● Sensor damaged. ● Pin circuit wiring or connectors at Black 7. <p>ECU Related</p> <ul style="list-style-type: none"> ● ECU-to-harness connection problem.

EFI SYSTEM

Code 0107

Component:	Manifold Absolute Pressure (TMAP)
Fault:	MAP Circuit Low Voltage or Open
Condition:	Intake manifold leak, open connection or faulty sensor.
Conclusion:	<p>TMAP Sensor Related</p> <ul style="list-style-type: none"> • Sensor malfunction. • Vacuum leaks from loose manifold or sensor. <p>Wire Harness Related</p> <ul style="list-style-type: none"> • Poor grounding or open circuit. • Wire harness and connectors loose, damaged or corroded. • Pin circuit wiring or connectors at Black 10, 11 and 16. <p>Bad TPS Learn.</p>

Code 0108

Component:	Manifold Absolute Pressure (TMAP)
Fault:	MAP Circuit High Voltage
Condition:	Intake manifold leak, shorted connection or faulty sensor.
Conclusion:	<p>TMAP Sensor Related</p> <ul style="list-style-type: none"> • Sensor malfunction. • Vacuum leaks from loose manifold or sensor. <p>Wire Harness Related</p> <ul style="list-style-type: none"> • Poor grounding. • Pin circuit wiring or connectors at Black 11. <p>Bad TPS Learn.</p>

Code 0112

Component:	Intake Air Temperature (TMAP)
Fault:	Intake Air Temperature Sensor Circuit Low Voltage
Condition:	Shorted connection, faulty sensor or shorted wire.
Conclusion:	<p>TMAP Sensor Related</p> <ul style="list-style-type: none"> • Sensor wiring or connection. <p>Engine Wiring Harness Related</p> <ul style="list-style-type: none"> • Pin circuits Black 10 and Black 8 may be damaged or routed near noisy signal (coils, alternator, etc.). • ECU-to-harness connection problem.

Code 0113

Component:	Intake Air Temperature (TMAP)
Fault:	Intake Air Temperature Sensor Circuit High Voltage or Open
Condition:	Shorted connection, faulty sensor, broken wire or connection.
Conclusion:	<p>TMAP Related</p> <ul style="list-style-type: none"> • Sensor wiring or connection. <p>Engine Wiring Harness Related</p> <ul style="list-style-type: none"> • Pin circuits ECU Black pin 10 and 8 may be damaged. • ECU-to-harness connection problem or broken wire.

Code 0117

Component:	Engine Temperature Sensor
Fault:	Engine Temperature Sensor Circuit Low Voltage
Condition:	Shorted connection, faulty sensor or shorted wire.
Conclusion:	<p>Temperature Sensor Related</p> <ul style="list-style-type: none"> • Sensor wiring or connection. <p>Engine Wiring Harness Related</p> <ul style="list-style-type: none"> • Pin circuits Black 10 and Black 14 maybe damaged or routed near noisy signal (coils, stator, etc.). • ECU-to-harness connection problem.

Code 0118

Component:	Engine Temperature Sensor
Fault:	Engine Temperature Sensor Circuit High Voltage or Open
Condition:	Shorted connection, faulty sensor, open connection or broken wire.
Conclusion:	<p>Temperature Sensor Related</p> <ul style="list-style-type: none"> • Sensor wiring or connection. <p>Engine Wiring Harness Related</p> <ul style="list-style-type: none"> • Pin circuits ECU Black pin 10 and 14 may be damaged. • ECU-to-harness connection problem or broken wire. <p>System Related</p> <ul style="list-style-type: none"> • Engine is operating above 176°C (350°F) temperature sensor limit.

Code 0122

Component:	Throttle Position Sensor (TPS)
Fault:	TPS Circuit Low Voltage or Open
Condition:	Open connection, broken wire or faulty sensor.
Conclusion:	<p>TPS Related</p> <ul style="list-style-type: none"> • TPS bad or worn internally. <p>Engine Wiring Harness Related</p> <ul style="list-style-type: none"> • Broken or shorted wire in harness. <ul style="list-style-type: none"> ECU Black pin 10 to TPS pin 1. ECU Black pin 12 to TPS pin 3. ECU Black pin 16 to TPS pin 2. <p>Throttle Body Related</p> <ul style="list-style-type: none"> • Throttle shaft inside TPS worn, broken, or damaged. • Throttle plate loose or misaligned. • Throttle plate bent or damaged allowing extra airflow past, or restricting movement. <p>ECU Related</p> <ul style="list-style-type: none"> • Circuit providing voltage or ground to TPS damaged. • TPS signal input circuit damaged.

Code 0123

Component:	Throttle Position Sensor (TPS)
Fault:	TPS Circuit High Voltage
Condition:	Shorted connection or faulty sensor.
Conclusion:	<p>TPS Sensor Related</p> <ul style="list-style-type: none"> • Sensor connector or wiring. • Sensor output affected or disrupted by dirt, grease, oil, wear. • Sensor loose on throttle body manifold. <p>Throttle Body Related</p> <ul style="list-style-type: none"> • Throttle shaft or bearings worn/ damaged. <p>Engine Wiring Harness Related</p> <ul style="list-style-type: none"> • ECU pins Black 10, 12 and 16 damaged (wiring, connectors). • ECU pins Black 10, 12 and 16 routed near noisy electrical signal (coils, alternator). • Intermittent 5 volt source from ECU (pin Black 16). • ECU-to-harness connection problem.

Code 0131

Component:	Oxygen Sensor
Fault:	O2S 1 Circuit Low Voltage
Condition:	Open connection, broken wire or faulty sensor.
Conclusion:	<p>Oxygen Sensor Related</p> <ul style="list-style-type: none"> • Sensor connector or wiring problem. • Sensor contaminated, corroded or damaged. • Poor ground path. • Pin circuit wiring or connectors. <ul style="list-style-type: none"> ECU Black pin 10 or 17. <p>TPS Learn Procedure Incorrect</p> <ul style="list-style-type: none"> • Lean condition (check oxygen sensor signal with VOA and see Oxygen Sensor section). <p>Engine wiring harness related such as a cut wire, broken or pinched.</p>

Code 0132

Component:	Oxygen Sensor
Fault:	O2S 1 Circuit High Voltage
Condition:	Shorted connection or faulty sensor.
Conclusion:	<p>Oxygen Sensor Related</p> <ul style="list-style-type: none"> • Sensor connector or wiring problem. • Sensor contaminated or damaged. • Poor ground path. • Pin circuit wiring or connectors. <ul style="list-style-type: none"> ECU Black pin 10 or Black pin 17. <p>Engine Wiring Harness Related</p> <ul style="list-style-type: none"> • Difference in voltage between sensed voltage and actual sensor voltage. • Short in wire harness.

EFI SYSTEM

Code 0171

Component:	Fuel System
Fault:	Maximum adaptation limit exceeded
Condition:	Fuel inlet screen/filter plugged, low pressure at high pressure fuel line, TPS malfunction, shorted connection, faulty sensor, low fuel or wrong fuel type.
Conclusion:	<p>Oxygen Sensor Related</p> <ul style="list-style-type: none"> ● Corrosion or poor connection. ● Sensor contaminated or damaged. ● Air leak into exhaust. ● Poor ground path. ● Pin circuit wiring or connectors. ECU Black pin 10 or Black pin 17. <p>TPS Sensor Related</p> <ul style="list-style-type: none"> ● Throttle plate position incorrect during Learn procedure. ● TPS problem or malfunction. <p>Engine Wiring Harness Related</p> <ul style="list-style-type: none"> ● Difference in voltage between sensed voltage and actual sensor voltage. ● Problem in wiring harness. ● ECU-to-harness connection problem. <p>Systems Related</p> <ul style="list-style-type: none"> ● Ignition (spark plug, plug wire, ignition coil). ● Fuel (fuel type/quality, injector, fuel pressure too low, fuel pump module or lift pump). ● Combustion air (air cleaner dirty/restricted, intake leak, throttle bores). ● Base engine problem (rings, valves). ● Exhaust system leak (muffler, flange, oxygen sensor mounting boss, etc.). ● Fuel in crankcase oil.

Code 0172

Component:	Fuel System
Fault:	Minimum adaptation limit exceeded
Condition:	Too high pressure at high pressure fuel line, TPS malfunction, shorted connection, faulty sensor or fuel pump module failure.
Conclusion:	<p>Oxygen Sensor Related</p> <ul style="list-style-type: none"> ● Sensor connector or wiring. ● Sensor contaminated or damaged. ● Poor ground path. ● Pin circuit wiring or connectors. ECU Black pin 10 or 17. <p>TPS Sensor Related</p> <ul style="list-style-type: none"> ● Throttle plate position incorrect during Learn procedure. ● TPS problem or malfunction. <p>Engine Wiring Harness Related</p> <ul style="list-style-type: none"> ● Difference in voltage between sensed voltage and actual sensor voltage. ● Problem in wiring harness. ● ECU-to-harness connection problem. <p>Systems Related</p> <ul style="list-style-type: none"> ● Ignition (spark plug, plug wire, ignition coil). ● Fuel (fuel type/quality, injector, fuel pressure too high, fuel pump module or lift pump). ● Combustion air (air cleaner dirty/restricted). ● Base engine problem (rings, valves). ● Fuel in crankcase oil. ● Fuel pump module is over filled. ● Lift pump diaphragm is ruptured.

Code 0174

Component:	Fuel System
Fault:	Lean fuel condition
Condition:	Fuel inlet screen/filter plugged, low pressure at high pressure fuel line, TPS malfunction, shorted connection or faulty sensor.
Conclusion:	<p>TPS Learn Incorrect</p> <ul style="list-style-type: none"> Lean condition (check oxygen sensor signal with VOA and see Oxygen Sensor). <p>Engine Wiring Harness Related</p> <ul style="list-style-type: none"> Pin circuit wiring or connectors. ECU pin Black 10, 12, 16 and 17. <p>Low Fuel Pressure</p> <ul style="list-style-type: none"> Plugged filters. Bad lift pump. <p>Oxygen Sensor Related</p> <ul style="list-style-type: none"> Sensor connector or wiring problem. Exhaust leak. Poor ground. <p>Poor system ground from ECU to engine, causing rich running while indicating lean.</p> <p>Fuel pump module connection. See Fuel Components.</p>

Code 0201

Component:	Fuel Injector
Fault:	Injector 1 Circuit Malfunction
Condition:	Injector damaged or faulty, shorted or open connection.
Conclusion:	<p>Injector Related</p> <ul style="list-style-type: none"> Injector coil shorted or opened. <p>Engine Wiring Harness Related</p> <ul style="list-style-type: none"> Broken or shorted wire in harness. ECU pin Black 5. Wiring from Ignition. <p>ECU Related</p> <ul style="list-style-type: none"> Circuit controlling injector #1 damaged.

Code 0202

Component:	Fuel Injector
Fault:	Injector 2 Circuit Malfunction
Condition:	Injector damaged or faulty, shorted or open connection.
Conclusion:	<p>Injector Related</p> <ul style="list-style-type: none"> Injector coil shorted or opened. <p>Engine Wiring Harness Related</p> <ul style="list-style-type: none"> Broken or shorted wire in harness. ECU pin Black 6. Wiring from Ignition. <p>ECU Related</p> <ul style="list-style-type: none"> Circuit controlling injector #2 damaged.

Code 0217

Component:	Engine Overheat Warning
Fault:	Overheat
Condition:	Engine operating at or above recommended temperature limit.
Conclusion:	<p>Provides an alert to operate of a condition that may cause damage to engine.</p> <ul style="list-style-type: none"> Typically this remedied by clearing debris blocking engine cooling air flow.

Code 0230

Component:	Fuel Pump
Fault:	Circuit Low Voltage or Open
Condition:	Shorted or open connection.
Conclusion:	<p>Fuel Pump Related</p> <ul style="list-style-type: none"> Fuel pump module open or shorted internally. <p>Engine Wiring Harness related</p> <ul style="list-style-type: none"> Broken or shorted wire in harness. ECU pin Black 9 or Grey 17. <p>ECU Related</p> <ul style="list-style-type: none"> ECU is damaged.

Code 0232

Component:	Fuel Pump
Fault:	Circuit High Voltage
Condition:	Shorted connection.
Conclusion:	<p>Fuel Pump Related</p> <ul style="list-style-type: none"> Fuel pump module damaged internally. <p>Charging Output System Too High.</p>

EFI SYSTEM

Code 0336

Component:	Crankshaft Position Sensor
Fault:	Crankshaft Position Sensor Noisy Signal
Condition:	Loose sensor, faulty/bad battery, shorted or faulty connection, faulty sensor or faulty sensor grounding.
Conclusion:	<p>Crankshaft Position Sensor Related</p> <ul style="list-style-type: none"> • Sensor connector or wiring. • Sensor loose. <p>Crankshaft Position Sensor Wheel Related</p> <ul style="list-style-type: none"> • Damaged teeth. • Gap section not registering. <p>Engine Wiring Harness Related</p> <ul style="list-style-type: none"> • Pin circuit wiring or connectors. ECU pin Black 4 and Black 13. • ECU-to-harness connection problem. <p>Ignition System Related</p> <ul style="list-style-type: none"> • Non-resistor spark plug(s) used. • Faulty or disconnected ignition coil or secondary lead.

Code 0337

Component:	Crankshaft Position Sensor
Fault:	Crankshaft Position Sensor No Signal
Condition:	Loose sensor, open or shorted connection or faulty sensor.
Conclusion:	<p>Crankshaft Position Sensor Related</p> <ul style="list-style-type: none"> • Sensor connector or wiring. • Sensor loose. <p>Crankshaft Position Sensor Wheel Related</p> <ul style="list-style-type: none"> • Damaged teeth. <p>Engine Wiring Harness Related</p> <ul style="list-style-type: none"> • Pin circuit wiring or connectors. ECU pin Black 4 or Black 13. • ECU-to-harness connection problem. <p>If code is stored in fault history and starts normally. Clear code, no other service required.</p>

Code 0351

Component:	Ignition Coil
Fault:	Cylinder 1 Ignition Coil Malfunction
Condition:	Broken wire in harness (may not be visible), shorted connection or faulty sensor.
Conclusion:	<p>Engine Wiring Harness Related</p> <ul style="list-style-type: none"> • Connection to ignition or fuse. • Pin circuit wiring or connectors. • ECU pin Black 1. • ECU-to-harness connection problem. <p>Ignition System Related</p> <ul style="list-style-type: none"> • Incorrect spark plug(s) used. • Poor connection to spark plug.

Code 0352

Component:	Ignition Coil
Fault:	Cylinder 2 Ignition Coil Malfunction
Condition:	Broken wire in harness (may not be visible), shorted connection or faulty sensor.
Conclusion:	<p>Engine Wiring Harness Related</p> <ul style="list-style-type: none"> • Connection to ignition or fuse. • Pin circuit wiring or connectors. ECU pin Grey 10. • ECU-to-harness connection problem. <p>Ignition System Related</p> <ul style="list-style-type: none"> • Incorrect spark plug(s) used. • Poor connection to spark plug.

Code 0562

Component:	System Voltage
Fault:	System Voltage Low
Condition:	Faulty voltage regulator, bad fuse or shorted connection.
Conclusion:	<p>Corroded Connections</p> <p>Bad Stator</p> <p>Bad Battery</p> <ul style="list-style-type: none"> • Low output charging system. • Poor magnet in flywheel. • Bad or missing fuse.

Code 0563

Component:	System Voltage
Fault:	System Voltage High
Condition:	Faulty voltage regulator or shorted connection.
Conclusion:	<p>Faulty Rectifier-Regulator</p> <p>Bad Stator.</p> <p>Bad Battery.</p>

Code 61

Component:	End of Code Transmission
------------	--------------------------

Troubleshooting Flow Chart

Following a flow chart provides an alternative method of troubleshooting EFI system. Chart will enable you to review entire system in about 10-15 minutes. Using chart, accompanying diagnostic aids (listed chart), and any signaled fault codes, you should be able to quickly locate any problems within system.

Flow Chart Diagnostic Aids

Diagnostic Aid #1 SYSTEM POWER

(MIL does not illuminate when key is turned ON)

NOTE: MIL is installed by vehicle OEM. Twelve volt supply to bulb will be part of vehicle wire harness. Rehlko key switch model will have MIL on engine with 12V supply to bulb.

Conclusion

- Battery
- Main system fuse
- MIL light bulb burned out
- MIL electrical circuit problem
Pin circuits Grey 3.
- Ignition switch
- Permanent ECU power circuit problem
Pin circuit Black 18.
- Switched ECU power circuit problem
Pin circuit Black 15.
- ECU grounds
- ECU

Diagnostic Aid #2 FAULT CODES

Refer to Diagnostic Fault Code Summary.

Diagnostic Aid #3 RUN/ON

(MIL remains ON while engine is running)*

Condition

NOTE: Either incandescent or LED type bulbs can be used for MIL as long as they do not draw more than 0.1 amps. Bulb needs to be rated at 1.4 Watts or less, or needs to have a total resistance of 140 Ω or more. LEDs typically draw less than 0.03 amps.

*All current fault codes will turn on MIL when engine is running.

Diagnostic Aid #4 CRANKSHAFT POSITION SENSOR

(MIL does not turn off during cranking)

Condition

- Crankshaft position sensor
- Crankshaft position sensor circuit problem, pin circuits Black 4 and Black 13.
- Crankshaft position sensor/toothed wheel air gap
- Toothed wheel
- Flywheel key sheared
- ECU

Diagnostic Aid #5 FUEL PUMP

(fuel pump not turning on)

Condition

- Inspect fuse(s)
- Fuel pump circuit problem, pin circuits Black 9 and Grey 17.
- Fuel pump module

Diagnostic Aid #6 IGNITION SYSTEM

(no spark)

Condition

- Spark plug
- Plug wire
- Coil
- Coil circuit(s), pin circuits Grey 10 and Black 1.
- ECU grounds
- ECU
- Vehicle safety interlocks, ground signal on safety wire.

Diagnostic Aid #7 FUEL SYSTEM ELECTRICAL

(no fuel delivery)

Condition

- No fuel
- Air in high pressure fuel line
- Fuel valve shut OFF
- Fuel filter/line plugged
- Injector circuit(s), pin circuits Black 5 and Black 6
- Injector
- ECU grounds
- ECU
- Lift pump not working

Diagnostic Aid #8 FUEL SYSTEM

(fuel pressure)

Low Fuel Pressure-Condition

- No fuel
- Fuel filter(s) plugged
- Fuel supply line plugged
- Lift fuel pump - insufficient fuel supply
- Fuel pump (lift or module) - internally plugged
- Pressure regulator not functioning properly inside fuel pump module.

Diagnostic Aid #9 BASIC ENGINE

(cranks but will not run)

Condition

- Refer to basic engine troubleshooting charts within Troubleshooting.

EFI SYSTEM

EFI Diagnostic Flow Diagram

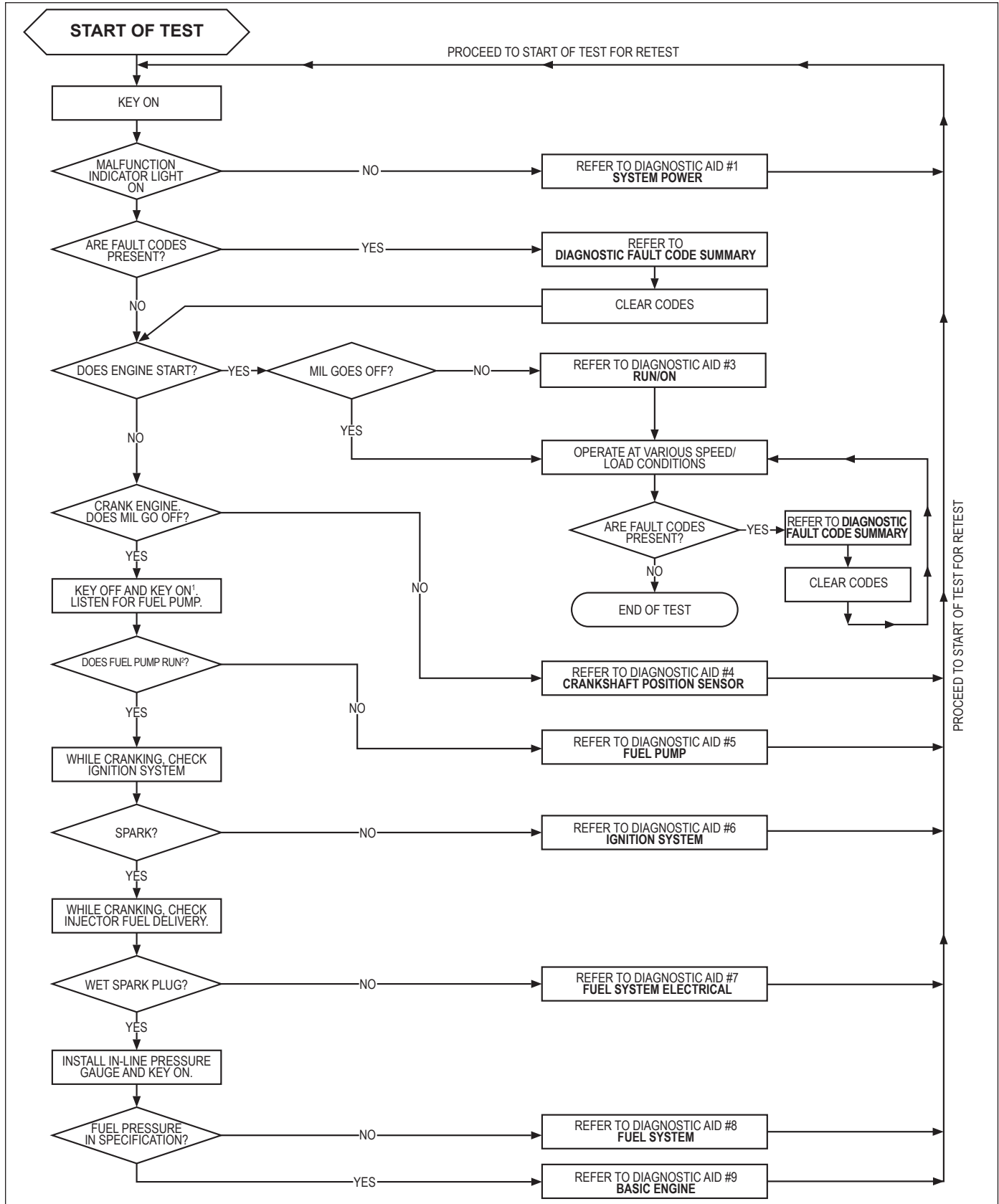

1. After turning key to OFF, wait 30 seconds before turning to ON to allow ECU to initiate another prime cycle.
2. Fuel pump module can be heard or a vibration can be felt to establish pump cycle. Fuel pump module will run for one 4-6 second prime cycle after key switch remains off for a minimum of 30 seconds.

GOVERNOR

Governed speed setting is determined by position of throttle control. It can be variable or constant, depending on engine application.

Governor is designed to hold engine speed constant under changing load conditions. Most engines are equipped with a centrifugal flyweight mechanical governor. Governor gear/flyweight mechanism of mechanical governor is mounted inside oil pan and is driven off gear on camshaft.

Governor Components

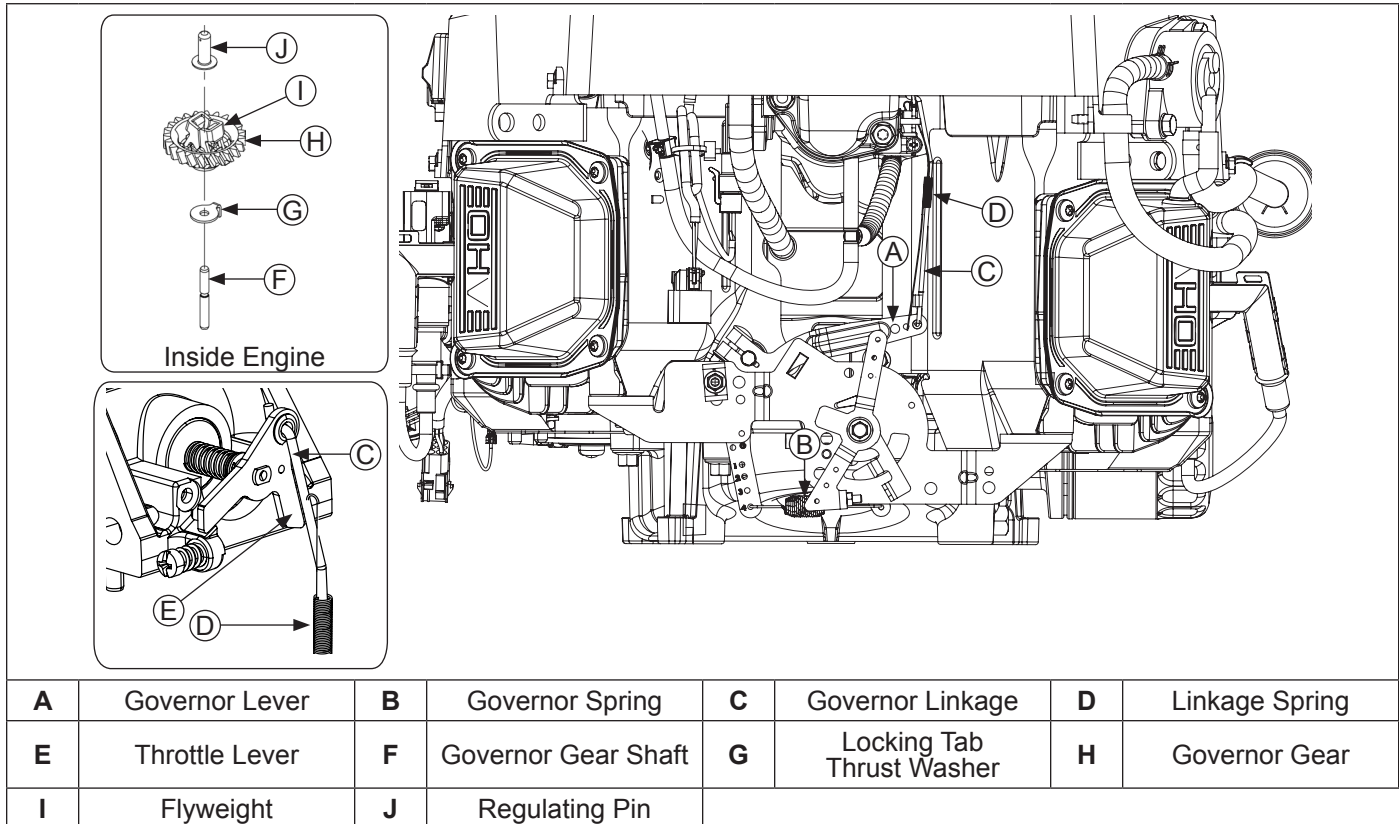

This governor design works as follows:

- Centrifugal force acting on rotating governor gear assembly causes flyweights to move outward as speed increases. Governor spring tension moves them inward as speed decreases.
- As flyweights move outward, they cause regulating pin to move outward.
- Regulating pin contacts tab on cross shaft causing shaft to rotate.
- One end of cross shaft protrudes through crankcase. Rotating action of cross shaft is transmitted to throttle lever of throttle body through external throttle linkage.
- When engine is at rest, and throttle is in fast position, tension of governor spring holds throttle plate open. When engine is operating, governor gear assembly is rotating. Force applied by regulating pin against cross shaft tends to close throttle plate. Governor spring tension and force applied by regulating pin balance each other during operation, to maintain engine speed.
- When load is applied and engine speed and governor gear speed decreases, governor spring tension moves governor arm to open throttle plate wider. This allows more fuel into engine, increasing engine speed. As

speed reaches governed setting, governor spring tension and force applied by regulating pin will again offset each other to hold a steady engine speed.

Governor Adjustments

NOTE: Do not tamper with governor setting. Overspeed is hazardous and could cause personal injury.

Initial Adjustment Procedure

Make this adjustment whenever governor arm is loosened or removed from cross shaft. Adjust as follows:

- Make sure throttle linkage is connected to governor arm and throttle lever on throttle body.
- Loosen nut holding governor lever to cross shaft.
- Move governor lever toward throttle body as far as it will go (wide open throttle) and hold in this position.
- Use 7 mm hex socket on end of cross shaft and rotate shaft counterclockwise (viewed from end) as far as it will turn, then torque nut to 6.8 N·m (60 in. lb.).

Lubrication System

This engine uses a combination pressure/splash lubrication system, delivering oil under pressure to crankshaft, connecting rod and main bearing surfaces. Other component areas are splash lubricated.

A high-efficiency gerotor oil pump maintains high oil flow and oil pressure, even at low speeds and high operating temperatures. A pressure relief valve limits maximum pressure of system. Oil pan must be removed to service oil pickup and oil pump.

Lubrication Components

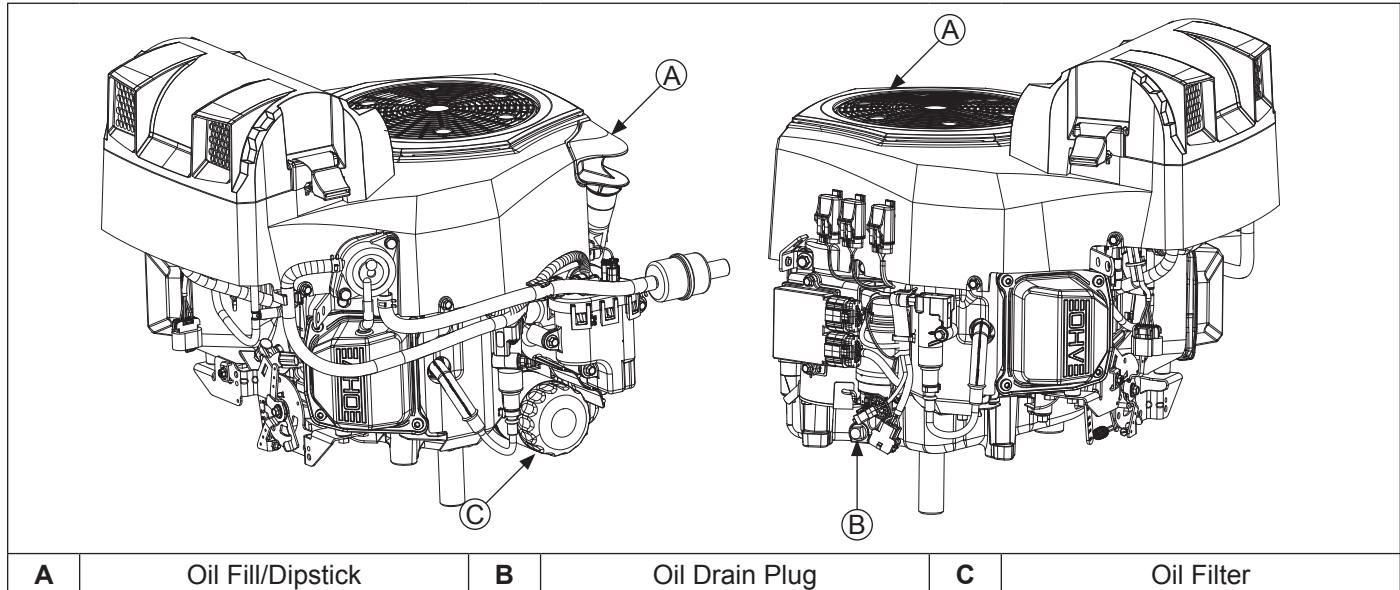

OIL RECOMMENDATIONS

Refer to Maintenance.

CHECK OIL LEVEL

NOTE: To prevent extensive engine wear or damage, never run engine with oil level below or above operating range indicator on dipstick.

Ensure engine is cool. Clean oil fill/dipstick areas of any debris.

1. Remove dipstick; wipe oil off.
2. Reinsert dipstick into tube; press completely down.
3. Remove dipstick; check oil level. Level should be at top of indicator on dipstick.
4. If oil is low on indicator, add oil up to top of indicator mark.
5. Reinstall and secure dipstick.

CHANGE OIL AND FILTER

Change oil while engine is warm.

1. Clean area around oil fill/dipstick. Remove drain plug and oil fill/dipstick. Allow oil to drain completely.
2. Clean area around oil filter. Place a container under filter to catch any oil and remove filter. Wipe off mounting surface. Reinstall drain plug. Torque to 13.6 N·m (10 ft. lb.).
3. Place new filter in shallow pan with open end up. Fill with new oil until oil reaches bottom of threads. Allow 2 minutes for oil to be absorbed by filter material.
4. Apply a thin film of clean oil to rubber gasket on new filter.
5. Refer to instructions on oil filter for proper installation.
6. Fill crankcase with new oil. Level should be at top of indicator on dipstick.
7. Reinstall oil fill/dipstick and tighten securely.
8. Start engine; check for oil leaks. Stop engine; correct leaks. Recheck oil level.
9. Dispose of used oil and filter in accordance with local ordinances.

OIL SENTRY™ (if equipped)

NOTE: Make sure oil level is checked before each use, and is maintained up to FULL or F mark on dipstick. This includes engines equipped with Oil Sentry™.

This switch is designed to prevent engine from starting in a low oil or no oil condition. Oil Sentry™ may not shut down a running engine before damage occurs. In some applications this switch may activate a warning signal. Read your equipment manuals for more information.

Oil Sentry™ pressure switch is installed in oil pan pressure port. On engines not equipped with Oil Sentry™ installation hole is sealed with a 1/8-27 N.P.T.F. pipe plug.

Installation

1. Apply pipe sealant with Teflon® (Loctite® PST® 592™ Thread Sealant or equivalent) to threads of switch.
2. Install switch into tapped hole in oil pan.
3. Torque switch to 4.5 N·m (40 in. lb.).

Testing

Compressed air, a pressure regulator, pressure gauge, and a continuity tester are required to test switch.

1. Connect continuity tester across blade terminal and metal case of switch. With 0 psi pressure applied to switch, tester should indicate continuity (switch closed).
2. Gradually increase pressure to switch. As pressure increases through range of 2-5 psi tester should indicate a change to no continuity (switch open). Switch should remain open as pressure is increased to 90 psi maximum.
3. Gradually decrease pressure through range of 2-5 psi. Tester should indicate a change to continuity (switch closed) down to 0 psi.
4. Replace switch if it does not operate as specified.

Electrical System

SPARK PLUGS



▲ CAUTION

Electrical Shock can cause injury.
Do not touch wires while engine is running.

Spark Plug Component and Details

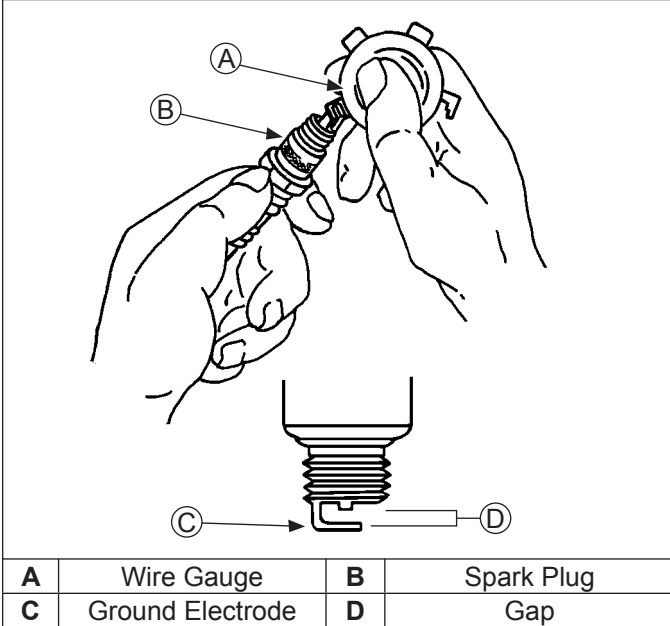

A	Wire Gauge	B	Spark Plug
C	Ground Electrode	D	Gap

NOTE: Do not clean spark plug in a machine using abrasive grit. Some grit could remain in spark plug and enter engine causing extensive wear and damage.

Engine misfire or starting problems are often caused by a spark plug that has improper gap or is in poor condition.

Engine is equipped with following spark plugs:

Gap	0.76 mm (0.030 in.)
Thread Size	14 mm
Reach	19.1 mm (3/4 in.)
Hex Size	15.9 mm (5/8 in.)

Refer to Maintenance for Repairs/Service Parts.

Service

Clean out spark plug recess. Remove plug and replace.

1. Check gap using wire feeler gauge. Adjust gap to 0.76 mm (0.030 in.).
2. Install plug into cylinder head.
3. Torque plug to 27 N·m (20 ft. lb.).

Inspection

Inspect each spark plug as it is removed from cylinder head. Deposits on tip are an indication of general condition of piston rings, valves, and fuel mixture.

Normal and fouled plugs are shown in following photos:

Normal

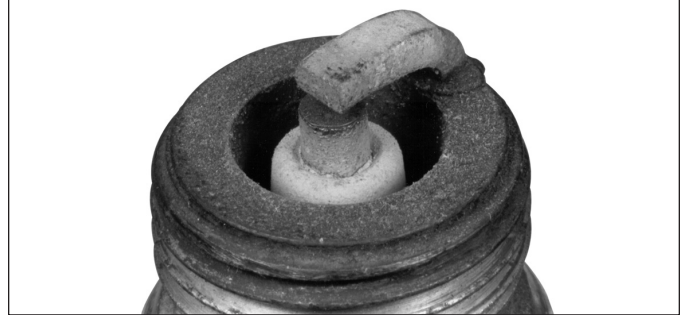

Plug taken from an engine operating under normal conditions will have light tan or gray colored deposits. If center electrode is not worn, plug can be set to proper gap and reused.

Worn



On a worn plug, center electrode will be rounded and gap will be greater than specified gap. Replace a worn spark plug immediately.

Wet Fouled



A wet plug is caused by excess fuel or oil in combustion chamber. Excess fuel could be caused by a restricted air cleaner, a fuel mixture problem, or operating engine with too much choke. Oil in combustion chamber is usually caused by a restricted air cleaner, a breather problem, worn piston rings, or valve guides.

Carbon Fouled



Soft, sooty, black deposits indicate incomplete combustion caused by a restricted air cleaner, over rich fuel mixture, weak ignition, or poor compression.

Overheated



Chalky, white deposits indicate very high combustion temperatures. This condition is usually accompanied by excessive gap erosion. Lean fuel mixture settings, an intake air leak, or incorrect spark timing are normal causes for high combustion temperatures.

BATTERY

A 12-volt battery with 400 cold cranking amps (cca) is generally recommended for starting in all conditions. A smaller capacity battery is often sufficient if an application is started only in warmer temperatures. Refer to following table for minimum capacities based on anticipated ambient temperatures. Actual cold cranking requirement depends on engine size, application, and starting temperatures. Cranking requirements increase as temperatures decrease and battery capacity shrinks. Refer to equipment's operating instructions for specific battery requirements.

Battery Size Recommendations

Temperature	Battery Required
Above 32°F (0°C)	200 cca minimum
0°F to 32°F (-18°C to 0°C)	250 cca minimum
-5°F to 0°F (-21°C to -18°C)	300 cca minimum
-10°F (-23°C) or below	400 cca minimum

If battery charge is insufficient to turn over engine, recharge battery.

Battery Maintenance

Regular maintenance is necessary to prolong battery life.

Battery Test

To test battery, follow manufacturer's instructions.

FUSES

This engine has 3 blade type automotive fuses. Replacement fuses must have same rating as blown fuse. Use fuse chart below to determine correct fuse.

Wire Color	Fuse Rating
2 Purple Wires	30-amp Fuse
2 Purple Wires	20-amp Fuse (Recoil Start)
1 Red Wire w/Black Stripe 1 Red Wire w/White Stripe	10-amp Fuse
2 Red Wires	10-amp Fuse

Fuse Replacement

1. Shut engine off and remove key.
2. Locate fuse holders.
3. Remove fuse cover and pull out fuse.
4. Inspect fuse for a solid fusible link or a broken fusible link. Replace fuse if fusible link is broken. If you are not sure if fusible link is broken, replace fuse.
5. Insert fuse into fuse holder until it is seated properly. Install fuse cover.
6. If replacement fuse fails, there is a problem within circuit. Diagnostics are required. Identify which circuit is affected (see EFI System for electrical schematic) by identifying failed fuse/circuit. Perform troubleshooting procedures appropriate for circuit fuse that failed.
7. Install fuse holder into fuse cover.

Electrical System

Test Ignition Systems

NOTE: If engine starts or runs during testing, you may need to ground kill lead to shut it down. Because you have interrupted kill circuit, it may not stop using switch.

Isolate and verify trouble is within engine.

1. If Rehlko diagnostic software is available, review "Safety System Active" status in Data Display screen. If yes is displayed, equipment safety circuit is active (seat switch/PTO switch/Safety interlocks, etc.). This must be corrected prior to continuing testing.

If diagnostic software is not available, locate connectors where wiring harnesses from engine and equipment are joined. Separate connectors and remove white kill lead from engine connector. Rejoin connectors and position or insulate kill lead terminal so it cannot touch ground. Try to start engine to verify whether reported problem is still present.

Condition	Possible Cause	Conclusion
Problem goes away.	Electrical System	Check key switch, wires, connections, safety interlocks, etc.
Problem persists.	Ignition or Electrical System	Leave kill lead isolated until all testing is completed. Identify white kill lead of engine wiring harness connector. Establish a connection to a known good ground location. Engine should kill completely. If not or only one cylinder is affected, test ignition coils.

Test for Spark

NOTE: If 2 testers are available, testing can be performed simultaneously for both cylinders. However, if only 1 tester is available, 2 individual tests must be performed. Side not being tested must have spark plug lead connected or grounded. Do not crank engine or perform tests with 1 spark plug lead disconnected and not grounded, or permanent coil damage may occur.

1. With engine stopped, disconnect 1 spark plug lead. Connect spark plug lead to post terminal of spark tester and attach tester clip to a good engine ground.
2. Crank engine over, establishing a minimum of 550-600 RPM, and observe tester(s) for spark.
3. Repeat spark test on opposite cylinder if cylinders are being tested individually.

Condition	Possible Cause	Conclusion
One side is not firing.	Wiring and Connections	Check all wiring, connections, and terminals on that side. If wiring is okay, replace ignition coil and retest for spark.
Tester shows spark but engine misses or won't run on that cylinder.	Spark Plug(s)	Try new spark plug(s).
Neither side is firing.	Ignition Switch/EFI System/Kill Lead	Recheck position of ignition switch and check for shorted kill lead.
Both cylinders have good spark but engine runs poorly or existing plug condition is questionable.	Spark Plug(s)	Install new spark plug(s) and retest engine performance.
1 cylinder has good spark and other cylinder has no or intermittent spark.	Ignition	Test ignition coils and connections.

BATTERY CHARGING SYSTEM

NOTE: Observe following guidelines to avoid damage to electrical system and components:

- Make sure battery polarity is correct. A negative (-) ground system is used.
- Disconnect rectifier-regulator plug and/or wiring harness plug before doing any electric welding on equipment powered by engine. Also, disconnect all other electrical accessories in common ground with engine.
- Prevent stator (AC) leads from touching or shorting while engine is running. This could damage stator.

These engines are equipped with a 15 or 25 amp regulated charging system.

15/25 Amp Regulated Charging System

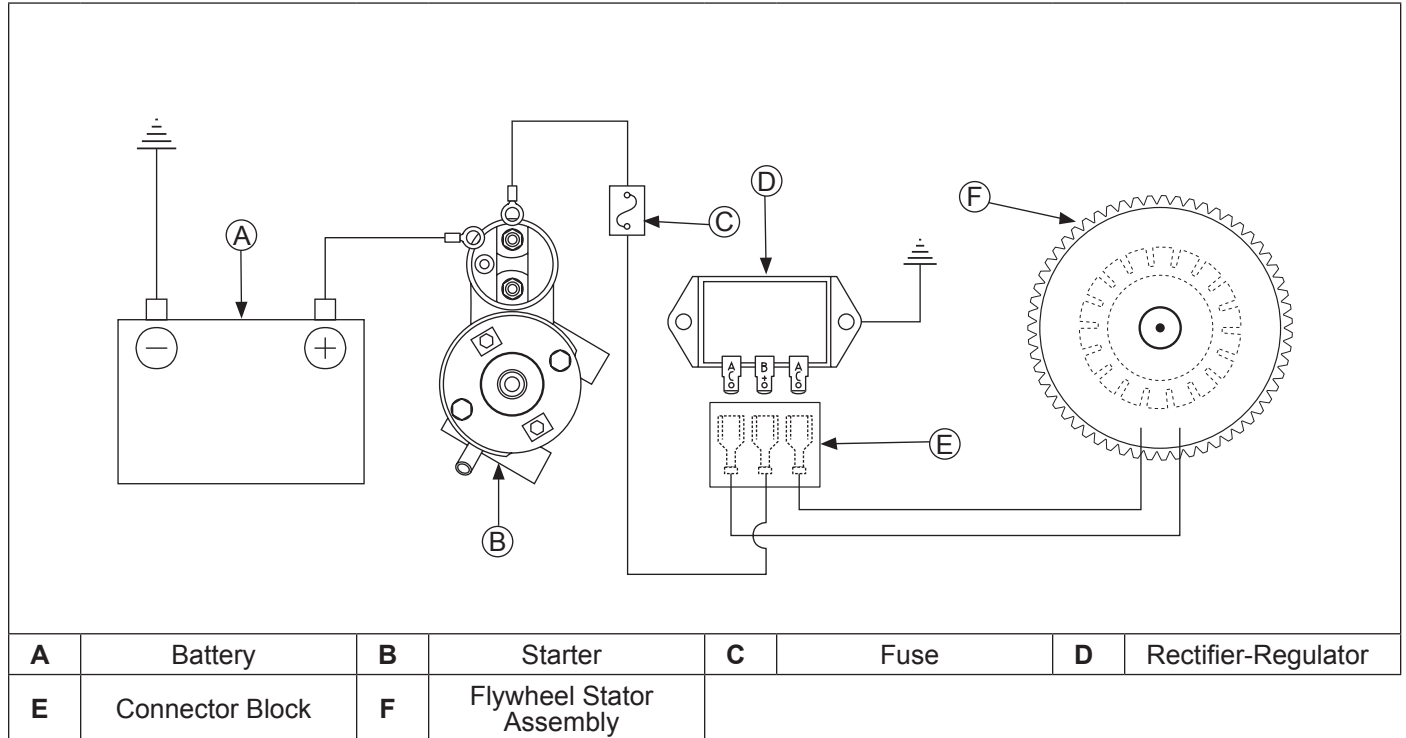

Electrical System

15/25 Amp Regulated Charging System

Stator

Stator is mounted on crankcase behind flywheel. Follow procedures in Disassembly and Reassembly if stator replacement is necessary.

Rectifier-Regulator

NOTE: When installing rectifier-regulator, take note of terminal positions and install plug correctly.

NOTE: Disconnect all electrical connections attached to rectifier-regulator. Testing may be performed with rectifier-regulator mounted or loose. Repeat applicable test procedure 2 or 3 times to determine condition of part.

Rectifier-regulator is mounted on backing shroud assembly. To replace it, disconnect plug, remove mounting screws, and ground lead.

Testing rectifier-regulator may be performed as follows, using appropriate rectifier-regulator tester.

To test 25 amp rectifier-regulators:

1. Connect single lead adapter in between B+ (center) terminal of rectifier-regulator being tested and squared single end of tandem adapter lead.
2. Connect tester ground lead (with spring clamp) to body of rectifier-regulator.
3. Connect red lead and 1 black lead to terminals on open end of tandem adapter lead (connections are not location specific).
4. Connect remaining black lead from tester to 1 outer AC terminal on rectifier-regulator.
5. Plug tester into proper AC outlet/power for tester being used. Turn on power switch. POWER light should be illuminated and 1 of 4 status lights may be on as well. This does not represent condition of part.
6. Press TEST button until a click is heard and then release. Momentarily 1 of 4 lights will illuminate indicating partial condition of part.

To test 15 amp rectifier-regulators:

1. Connect tester ground lead (with spring clamp) to body of rectifier-regulator being tested.
2. Connect tester red lead to B+ terminal of rectifier-regulator and 2 black tester leads to 2 AC terminals.
3. Plug tester into proper AC outlet/power for tester being used. Turn on power switch. POWER light should be illuminated and 1 of 4 status lights may be on as well. This does not represent condition of part.
4. Press TEST button until a click is heard and then release. Momentarily 1 of 4 status lights will illuminate indicating condition of part.

Condition	Conclusion	
	25 amp	15 amp
OK (green) light comes on and stays steady.	Disconnect tester black lead attached to 1 AC terminal and reconnect it to other AC terminal. Repeat test. If OK (green) light comes on again, part is good and may be used.	Part is good and may be used.
NOTE: A flashing LOW light can also occur as a result of an inadequate ground lead connection. Make certain connection location is clean and clamp is secure. Other lights come on.	Rectifier-regulator is faulty and should not be used.	

15/25 Amp Battery Charging Systems

NOTE: Always zero ohmmeter on each scale before testing to ensure accurate readings. Voltage tests should be made with engine running at 3600 RPM with no load. Battery must be good and fully charged.

When problems occur in keeping battery charged or battery charges at high rate, charging system or battery might be causing problems.

To test charging system for no charge to battery:

1. Insert an ammeter in B+ lead from rectifier-regulator. With engine running at 3600 RPM and B+ (at terminal on rectifier-regulator) to ground using a DC voltmeter.

If voltage is 13.8 volts or more, place a minimum load of 5 amps (turn on lights if 60 watts or more, or place a 2.5 ohm, 100 watt resistor across battery terminals) on battery to reduce voltage. Observe ammeter.

Condition	Conclusion
Charge rate increases when load is applied.	Charging system is OK and battery was fully charged.
Charge rate does not increase when load is applied.	Test stator and rectifier-regulator (steps 2 and 3).

2. Remove connector from rectifier-regulator. With engine running at 3600 RPM, measure AC voltage across stator leads using an AC voltmeter.

Condition	Conclusion
Voltage is 28 volts or more.	Stator is OK. Rectifier-regulator is faulty; replace.
Voltage is less than 28 volts.	Stator is faulty; replace. Test stator further using an ohmmeter (steps 3 and 4).

3. With engine stopped, measure resistance across stator leads using an ohmmeter.

Condition	Conclusion
Resistance is 0.064/0.2 ohms.	Stator is OK.
Resistance is 0 ohms.	Stator is shorted; replace.
Resistance is infinity ohms.	Stator is open; replace.

4. With engine stopped, measure resistance from each stator lead to ground using an ohmmeter.

Condition	Conclusion
Resistance is infinity ohms (no continuity).	Stator is OK (not shorted to ground).
Resistance (or continuity) measured.	Stator leads are shorted to ground; replace.

To test charging system for battery continuously charging at high rate:

1. With engine running at 3600 RPM, measure voltage from B+ lead to ground using a DC voltmeter.

Condition	Conclusion
Voltage is 14.7 volts or less.	Charging system is OK. Battery is unable to hold charge; service or replace.
Voltage is more than 14.7 volts.	Faulty rectifier-regulator; replace.

Starter System

NOTE: Do not crank engine continuously for more than 10 seconds. Allow a 60 second cool-down period between starting attempts. Failure to follow these guidelines can burn out starter motor.

NOTE: If engine develops sufficient speed to disengage starter but does not keep running (a false start), engine rotation must be allowed to come to a complete stop before attempting to restart engine. If starter is engaged while flywheel is rotating, starter pinion and flywheel ring gear may clash and damage starter.

NOTE: If starter does not crank engine, shut off starter immediately. Do not make further attempts to start engine until condition is corrected.

NOTE: Do not drop starter or strike starter frame. Doing so can damage starter.

NOTE: Battery must be tested and confirmed acceptable prior to troubleshooting starter system. Follow battery or OEM battery testing procedures.

Engines in this series use solenoid shift or retractable starters.

Troubleshooting-Starting Difficulties

Condition	Possible Cause	Conclusion
Starter does not energize.	Battery	Check specific gravity of battery and battery state of charge. If low, recharge or replace battery as necessary.
	Wiring	Clean corroded connections and tighten loose connections. Replace wires in poor condition and with frayed or broken insulation.
	Starter Switch or Solenoid	By-pass switch or solenoid with a jumper wire. If starter cranks normally, replace faulty components. Consult with OEM electrical system service procedures for OEM related component diagnostics. Perform solenoid test procedure.
Starter energizes but turns slowly.	Battery	Check specific gravity of battery and battery state of charge. If low, recharge or replace battery as necessary.
	Transmission or Engine	Make sure clutch or transmission is disengaged or placed in neutral. This is especially important on equipment with hydrostatic drive. Transmission must be exactly in neutral to prevent resistance which could keep engine from starting. Check for seized engine components such as bearings, connecting rod, and piston.

SOLENOID SHIFT STARTERS

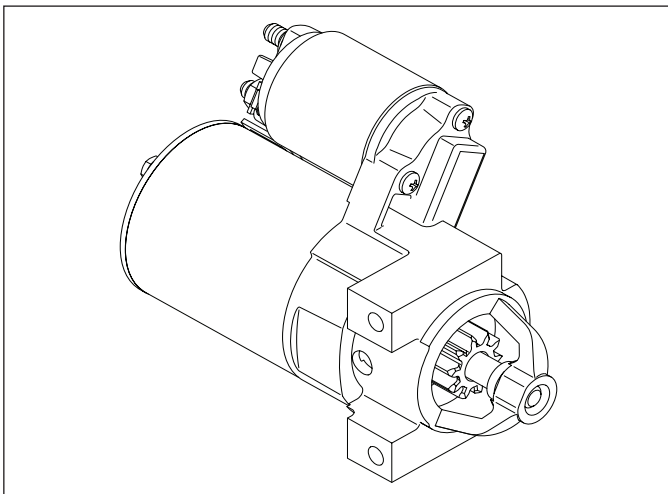

When power is applied to starter electric solenoid moves drive pinion out onto drive shaft and into mesh with flywheel ring gear. When pinion reaches end of drive shaft it rotates flywheel and cranks engine.

When engine starts and start switch is released, starter solenoid is deactivated, drive lever moves back, and drive pinion moves out of mesh with ring gear into retracted position.

Inspection

Drive Pinion

Check and inspect following areas:

- Pinion teeth for abnormal wear or damage.
- Surface between pinion and clutch mechanism for nicks or irregularities which could cause seal damage.
- Check drive clutch by holding clutch housing and rotating pinion. Pinion should rotate in only 1 direction.

Solenoid Tests

NOTE: Please perform following testing as near to conditions during failure.

Before Starting

- Disable ignition system: with key off, unplug EFI Electronic Control Unit (ECU) or remove both 10 amp (red) engine mounted fuses.
- Battery voltage should be tested and must be at 12.4 VDC or higher. Do not proceed if battery voltage is less than 12.4 VDC as battery should be charged.
- Test meter leads before use. (Set meter to Ohms and check for resistance reading of less than 0.5 Ohm.)
- If available, use clamping meter leads to assist with testing.
- Set meter to next highest voltage scale that includes 12 VDC.
- When taking readings, allow meter to stabilize before recording. Reading should stabilize after 3 to 5 seconds. If reading continues to drop while cranking, stop test and perform a battery load test.

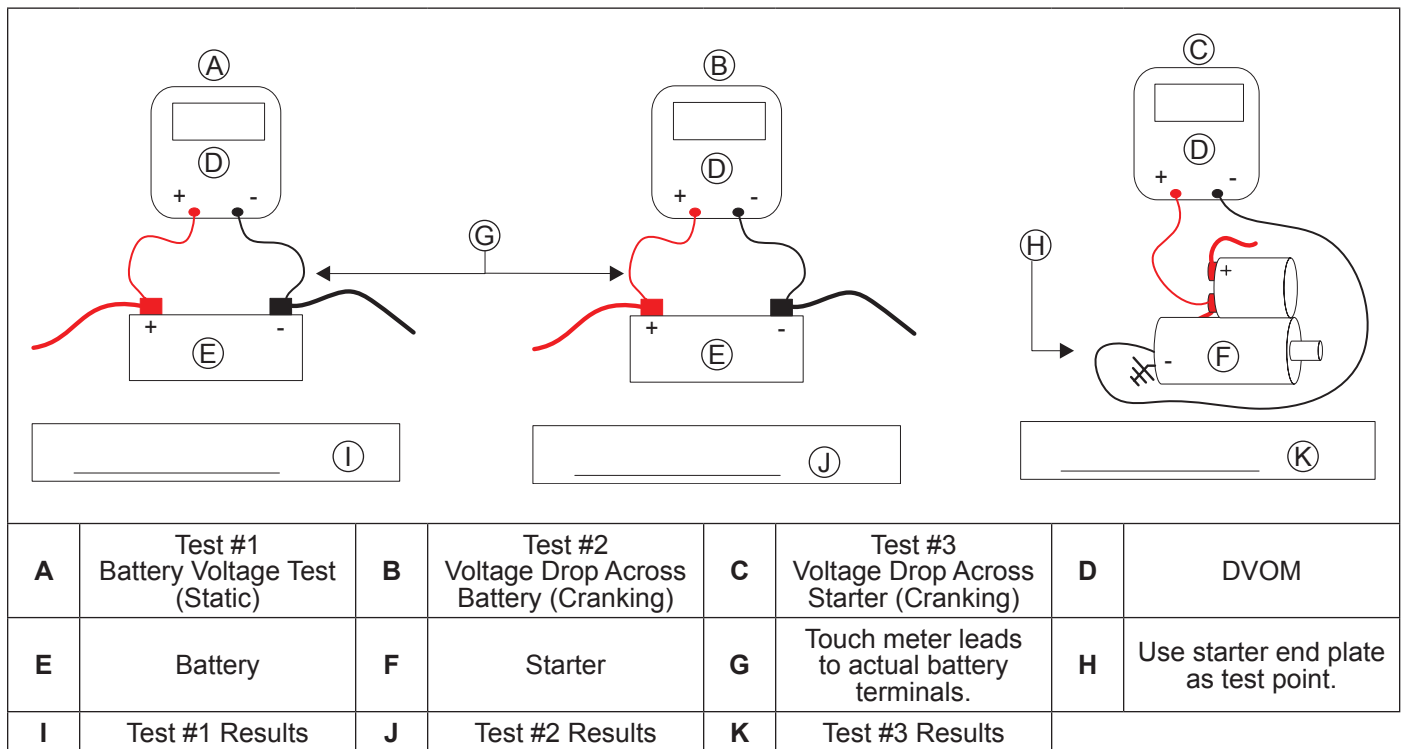

Test 1 Conclusions

- If battery voltage is above 12.4 VDC continue to Test 2.
- If voltage is below 12.4 VDC, charge battery and retest.
- If battery will not hold a charge it should be replaced before continuing test or replacing starter.

Test 2 Conclusions

- If battery cranking voltage is above 9.0 VDC continue to Test 3.
- If battery cranking voltage is below 9.0 VDC you should check battery by using a load tester. Also check for external engine load.

Test 3 Conclusions

- If difference between test 2 and test 3 is greater than 1 VDC check all positive and negative electrical connections for corrosion and/or loose fasteners in starter circuit.

Starter System

RETRACTABLE STARTERS

	▲ WARNING	Retractable starters contain a powerful, recoil spring that is under tension. Always wear safety goggles when servicing retractable starters and carefully follow instructions in Retractable Starter for relieving spring tension.
	Uncoiling Spring can cause severe injury. Wear safety goggles or face protection when servicing retractable starter.	

Retractable Starter Components

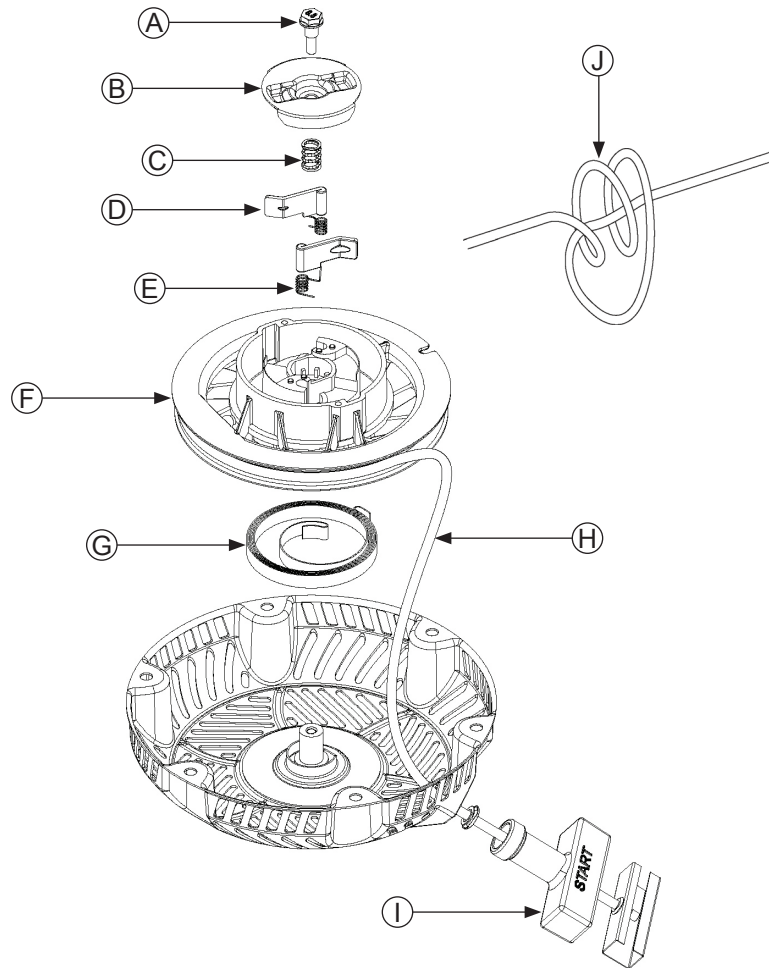

A	Center Screw	B	Drive Plate	C	Friction Spring	D	Drive Pawl (Dogs)
E	Drive Pawl Springs	F	Pulley	G	Recoil Spring	H	Starter Rope
I	Starter Handle	J	Double Left-Hand Knot				

Remove Starter

1. Remove screws securing starter to blower housing.
2. Remove starter assembly.

Rope Replacement

NOTE: Do not allow pulley/spring to unwind. Enlist aid of a helper if necessary.

Rope can be replaced without complete starter disassembly.

1. Remove starter assembly from engine.
2. Pull rope out approximately 12 in. and tie a temporary (slip) knot in it to keep it from retracting into starter.
3. Pull knot end out of handle, untie knot, and slide handle off.
4. Hold pulley firmly and untie slipknot. Allow pulley to rotate slowly as spring tension is released.
5. When all spring tension on starter pulley is released, remove rope from pulley.
6. Tie a double left-hand knot in one end of new rope.
7. Rotate pulley counterclockwise to pre-tension spring (approximately 4 full turns of pulley).
8. Continue rotating pulley counterclockwise until rope hole in pulley is aligned with rope guide bushing of starter housing.
9. Insert unknotted end of new rope through rope hole in starter pulley and rope guide bushing of housing.
10. Tie a slipknot approximately 12 in. from free end of rope. Hold pulley firmly and allow it to rotate slowly until slipknot reaches guide bushing of housing.
11. Insert starter rope through starter handle and tie a double, left-hand knot at end of starter rope. Insert knot into hole in handle.
12. Untie slip knot and pull on starter handle until starter rope is fully extended. Slowly retract starter rope into starter assembly. If recoil spring is properly tensioned, starter rope will retract fully and starter handle will stop against starter housing.

Pawls (dogs) Replacement

1. Install a clamp to hold pulley in starter housing and prevent it from rotating.
2. Unscrew center screw and lift off drive plate.
3. Note positions of pawls and pawl springs before removing. Remove parts from pulley.
4. Install pawl springs and pawls into pawl slots of pulley. All parts must be dry.
5. Position drive plate over pawls, aligning actuating slots in place with raised sections on each drive pawl. Torque center screw to 5-6 N·m (44-54 in. lb.).
6. Remove clamp and pull starter rope out part way to check operation of pawls.

Install Starter

1. Install retractable starter onto blower housing leaving screws slightly loose.
2. Pull starter handle out until pawls engage in drive cup. Hold handle in this position and torque mounting screws to 7.3 N·m (65 in. lb.).

Emission Compliant Systems

EVAPORATIVE EMISSION COMPLIANT SYSTEM

Carbon Canister System

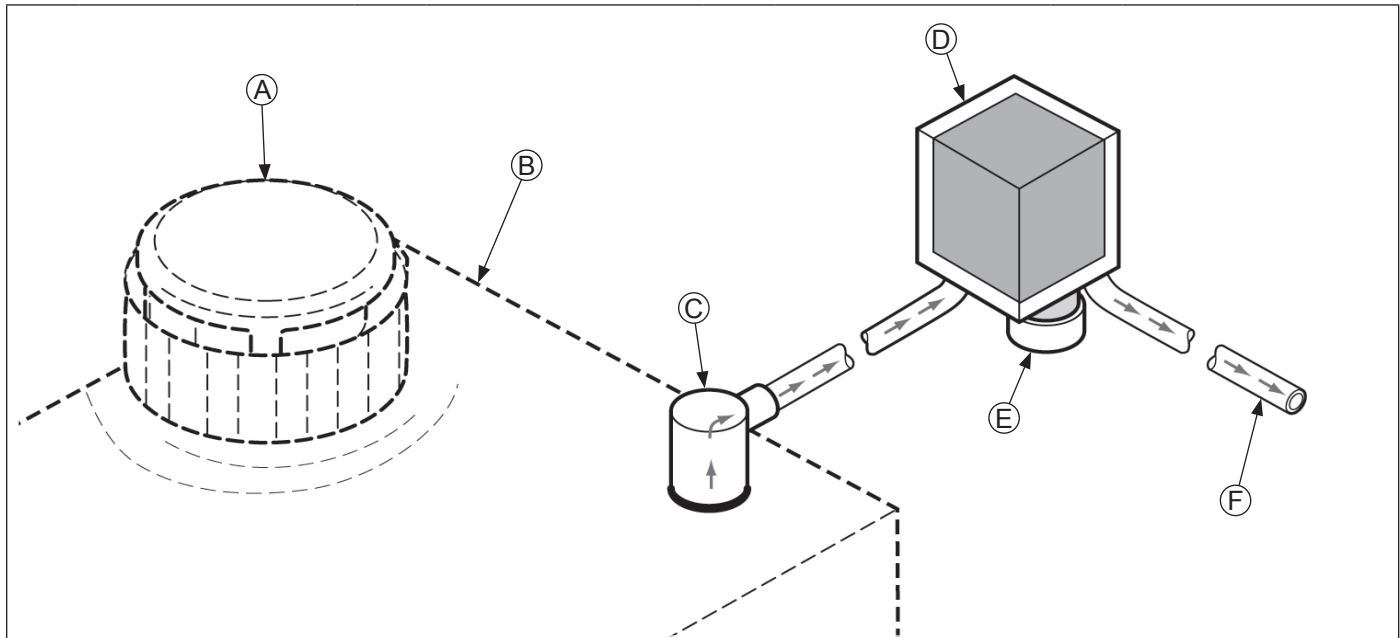

A	Fuel Tank Cap	B	Fuel Tank	C	Roll Over Valve (ROV)	D	Carbon Canister
E	Canister Breather Filter	F	To Throttle Body				

For equipment to be Tier III compliant, it may be fitted with a Rehiko supplied canister vapor recovery system, or a system developed and installed by Original Equipment Manufacturer (OEM). Details on Rehiko system are included below.

Operation

Fuel vapors travel from fuel tank through tubing to carbon canister. On intake stroke of engine fuel vapors are drawn in through a port in throttle body and burned with fuel charge.

Maintenance

On Rehiko-supplied canisters, breather filter can be removed and cleaned with hot soapy water, dried and reinstalled. Do not oil breather screen. This is done periodically or if system operation is suspect. Carbon canister is sealed and requires no maintenance.

In some applications or installations, OEM will have installed a different canister or fuel vapor recovery system. See OEM equipment documentation for service or maintenance information.

Disassembly/Inspection and Service

	▲ WARNING	Before working on engine or equipment, disable engine as follows: 1) Disconnect spark plug lead(s). 2) Disconnect negative (-) battery cable from battery.
	Accidental Starts can cause severe injury or death. Disconnect and ground spark plug lead(s) before servicing.	

External Engine Components

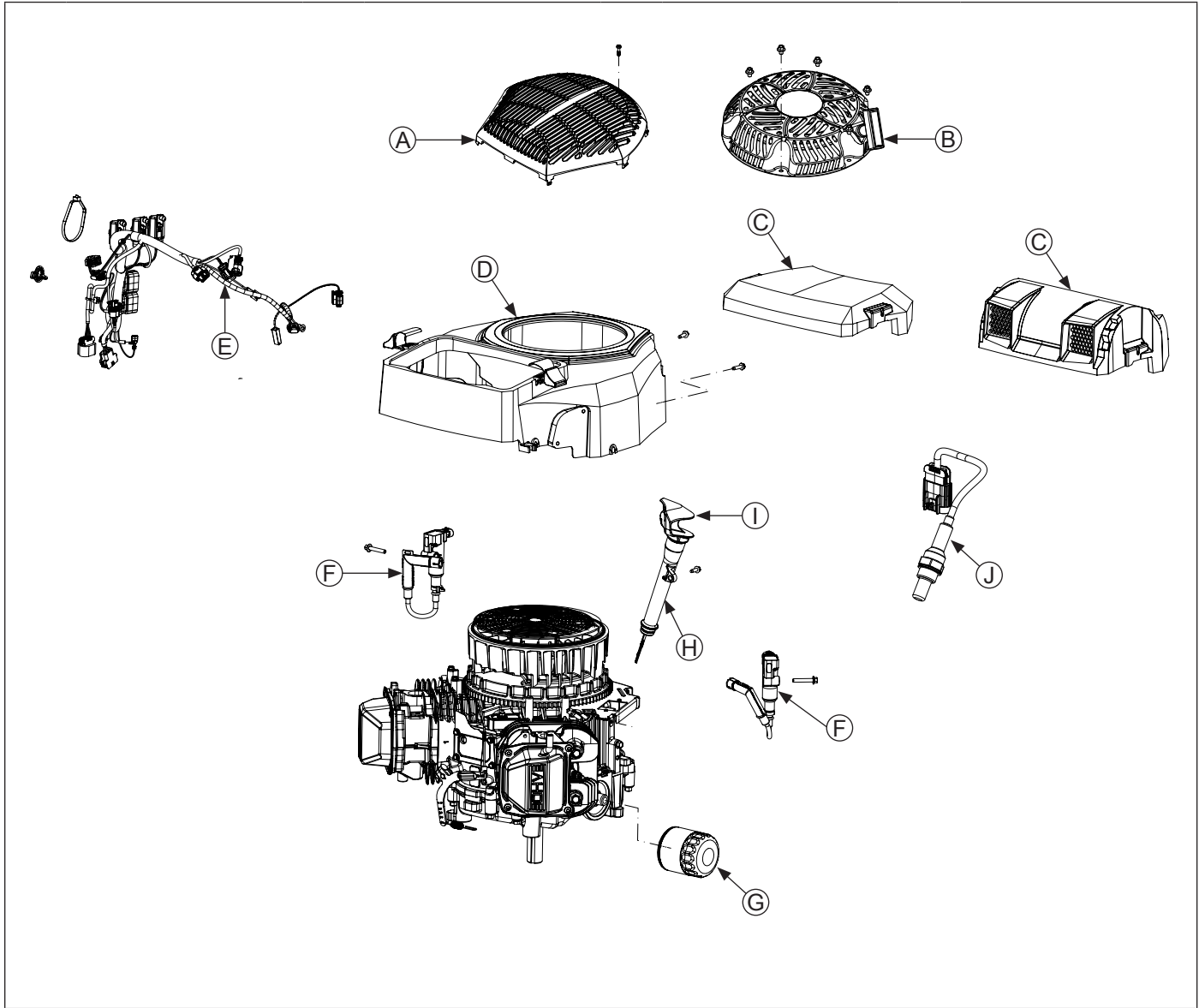

A	Fixed Guard	B	Retractable Starter	C	Air Cleaner Cover	D	Blower Housing
E	Wire Harness	F	Ignition Coil	G	Oil Filter	H	Dipstick Tube
I	Oil Fill/Dipstick	J	Oxygen Sensor				

Disassembly/Inspection and Service

Clean all parts thoroughly as engine is disassembled. Only clean parts can be accurately inspected and gauged for wear or damage. There are many commercially available cleaners that will quickly remove grease, oil and grime from engine parts. When such a cleaner is used, follow manufacturer's instructions and safety precautions carefully.

Make sure all traces of cleaner are removed before engine is reassembled and placed into operation. Even small amounts of these cleaners can quickly break down lubricating properties of engine oil.

Disconnect Spark Plug Leads

NOTE: Pull on boot only, to prevent damage to spark plug lead.

1. Disconnect leads from spark plugs.
2. Disconnect connectors from ignition coils.
Ignition coil may remain attached to baffle after being unplugged or disconnected.
3. Shut off fuel supply.

Drain Oil From Crankcase and Remove Oil Filter

1. Remove oil fill/dipstick and oil drain plug.
2. Allow ample time for oil to drain from crankcase and oil filter.
3. Remove and appropriately discard oil filter.

Remove Muffler (if equipped)

NOTE: Removing oxygen sensor is not required to remove exhaust system.

1. Remove exhaust system and attaching hardware from engine.
2. Disconnect oxygen sensor connector from wire harness.

Remove Dipstick Tube

Remove screw securing dipstick tube to backing plate. Remove dipstick tube.

Remove Pulse Fuel Pump

	⚠ WARNING
	Explosive Fuel can cause fires and severe burns. Do not fill fuel tank while engine is hot or running.
Gasoline is extremely flammable and its vapors can explode if ignited. Store gasoline only in approved containers, in well ventilated, unoccupied buildings, away from sparks or flames. Spilled fuel could ignite if it comes in contact with hot parts or sparks from ignition. Never use gasoline as a cleaning agent.	

Pulse Fuel Pump Components

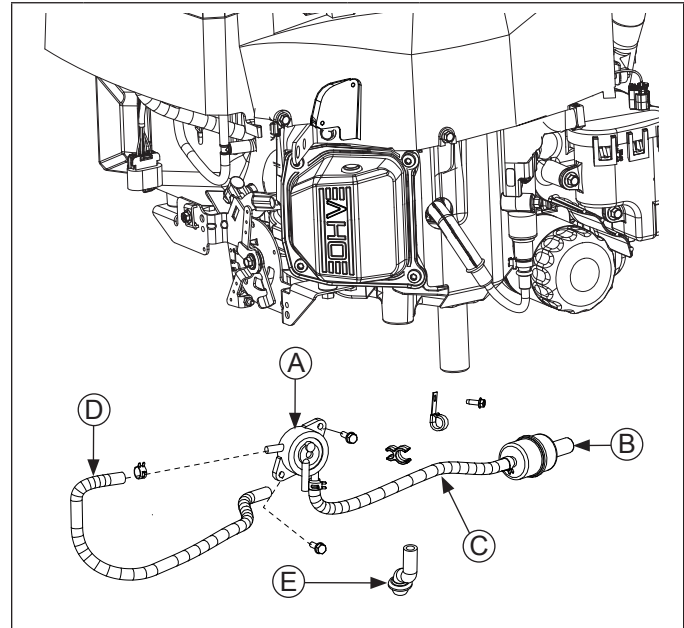

A	Pulse Fuel Pump	B	Fuel Filter
C	Inlet Line	D	Outlet Line
E	Pulse Line		

1. Disconnect outlet line and pulse line from fuel pump. Inlet line with fuel filter may stay attached to fuel pump.
2. Disconnect pulse (vacuum) line from valve cover.
3. Remove 2 screws securing fuel pump to blower housing.
4. Note or mark orientation of fuel pump, then remove fuel pump with lines attached.

Remove Retractable Starter (if equipped)

Remove screws securing retractable starter to blower housing. Remove starter.

Disassembly/Inspection and Service

Remove Fixed Guard and Chopper Screen (if equipped)

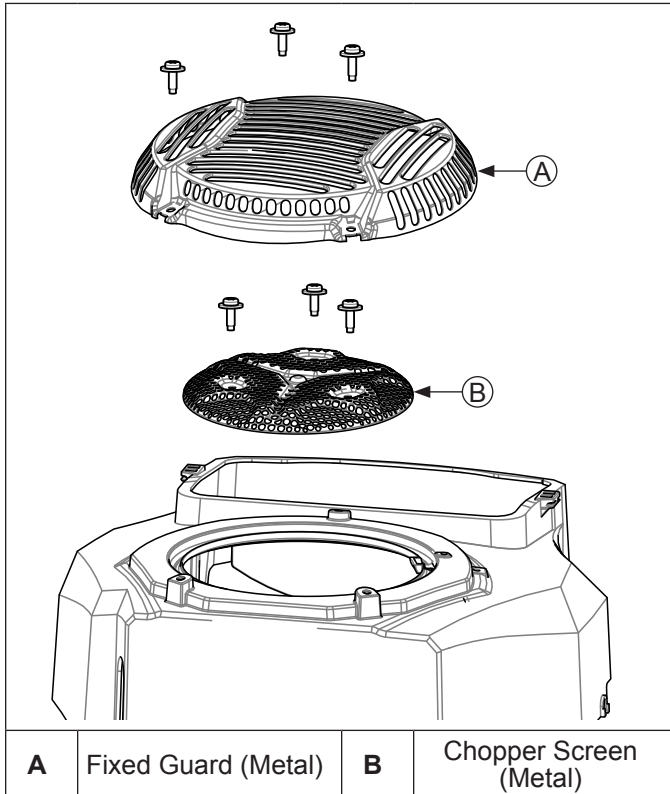

1. Remove screws securing metal guard to blower housing. Remove guard.
2. Remove screws securing chopper screen to screen cup. Remove screen from housing.

Remove Blower Housing

1. Remove air cleaner cover.
2. Disconnect fuses from fuse holders on blower housing and allow them to hang.
3. Loosen screws securing blower housing. Screws may remain in slotted holes.
4. Remove screw securing cable clip on #1 side of blower housing.
5. Remove blower housing.

Remove Fuel Pump Module (FPM)

	⚠ WARNING
	<p>Explosive Fuel can cause fires and severe burns.</p> <p>Do not fill fuel tank while engine is hot or running.</p>

Gasoline is extremely flammable and its vapors can explode if ignited. Store gasoline only in approved containers, in well ventilated, unoccupied buildings, away from sparks or flames. Spilled fuel could ignite if it comes in contact with hot parts or sparks from ignition. Never use gasoline as a cleaning agent.

FPM Components

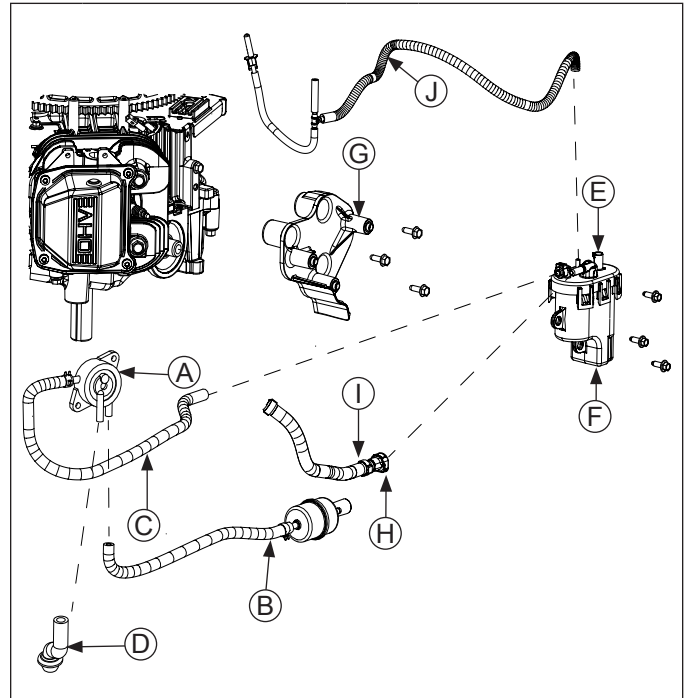

A	Pulse Pump	B	Inlet Line
C	Outlet to FPM	D	Pulse Line
E	Electrical Connector	F	FPM
G	FPM Baffle	H	High Pressure Fuel Line Connector
I	Oetiker Clamp	J	Vent Hose Assembly

1. Remove screws securing FPM to baffle.
2. Lift grey locking tab and squeeze to disconnect electrical connector.
3. Using Hose Removal Tool (see Tools and Aids), disconnect vent line from top of FPM.
4. Wrap a shop towel completely around high pressure fuel line connector.

Using a small screwdriver under hose connector, press release button and slowly pull connector away from FPM, allowing shop towel to absorb any residual fuel in high pressure fuel line. Any spilled fuel must be wiped up immediately.

5. Keep inlet fuel line attached at FPM.
Do not cut Oetiker clamp unless fuel line or FPM are being replaced.
6. Remove screws securing FPM baffle to crankcase and remove baffle.

Disassembly/Inspection and Service

Remove Throttle Controls

Control Bracket Components

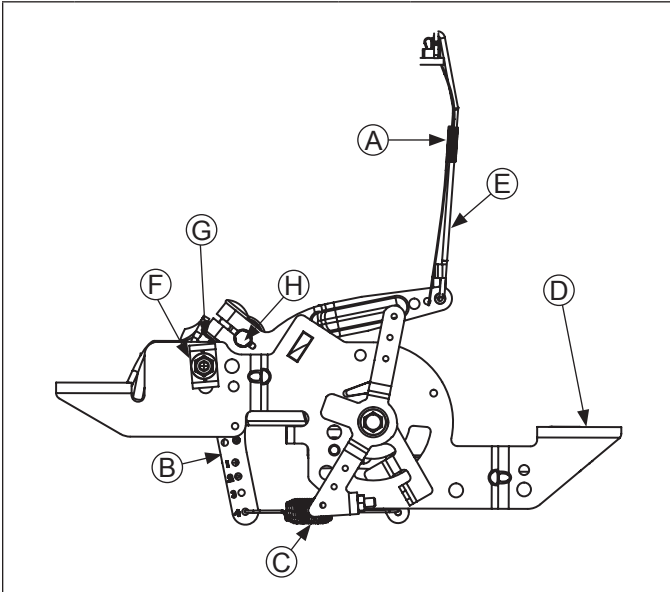

A	Linkage Spring	B	Governor Lever
C	Governor Spring	D	Control Bracket
E	Governor Linkage	F	Cable Clamp
G	Nut	H	Cross Shaft

1. Remove screws securing throttle control bracket to cylinder heads.
2. Unhook governor spring from governor lever. Note hole locations for reassembly.

Remove External Governor Controls

Loosen nut and remove governor lever from cross shaft. Leave governor lever attached to throttle and governor linkage.

Air Cleaner/Throttle Body Components

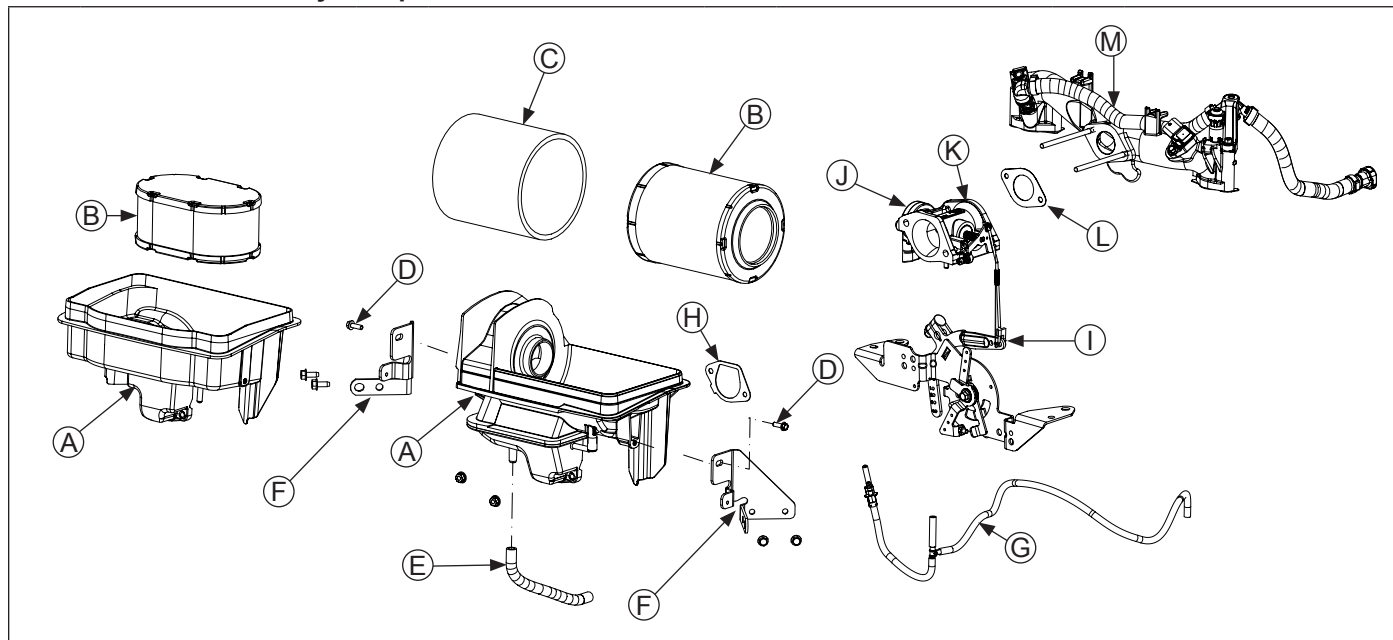

A	Air Cleaner Base	B	Air Cleaner Element	C	Precleaner	D	Side Screw
E	Breather Hose	F	Combination Air Cleaner Base Bracket/Lifting Strap	G	Vent Hose Assembly	H	Air Cleaner Gasket
I	Throttle Body/Throttle Linkage/Governor Lever Assembly	J	Throttle Position Sensor (TPS)	K	Throttle Body	L	Throttle Body Gasket
M	Intake Manifold						

Remove Air Cleaner and Throttle Body

1. Remove screws securing combination air cleaner base brackets/lifting straps to each cylinder head.
2. Remove throttle body/air cleaner base mounting nuts.
3. Disconnect breather hose from air cleaner base.
4. Remove side screws securing air cleaner base and remove base and gasket.
5. Remove air cleaner element and precleaner (if equipped) from air cleaner base for servicing.
6. Disconnect throttle position sensor (TPS) connector.
7. Disconnect vent hose assembly from throttle body.
8. Remove throttle body, throttle linkage and governor lever as an assembly.
9. Remove throttle body gasket.
10. If necessary, throttle body, throttle linkage, and governor lever can be separated. Reattach bushings to linkage following separation to avoid losing them.

Disassembly/Inspection and Service

Starter and Electronic Control Unit (ECU) Components

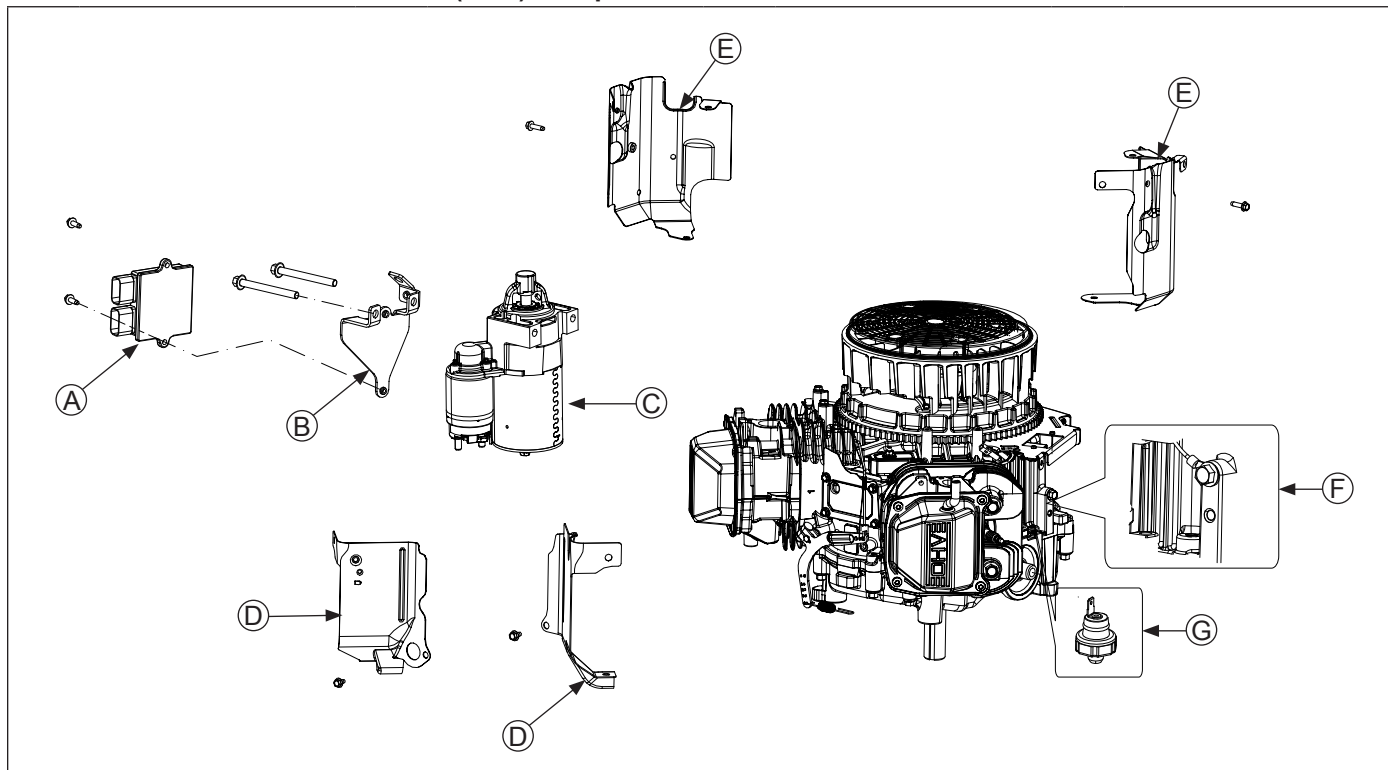

A	ECU	B	ECU Bracket	C	Starter	D	Inner Baffle
E	Outer Baffle	F	Engine Temperature Sensor	G	Oil Sentry™ Switch		

Remove ECU

1. Remove screws securing ECU to bracket.
2. Disconnect Black and Grey electrical connectors from ECU.

Remove ECU Bracket and Electric Starter Motor

1. Disconnect leads from starter.
2. Remove screws, ECU bracket, and starter.

Remove Inner and Outer Baffles

NOTE: Outer baffles fasten onto top and side of backing plate.

NOTE: Before removing, note routing of wires for reassembly.

NOTE: Wires must be loose in order to remove outer baffle on cylinder #2.

1. Disconnect lead from Oil Sentry™ switch.
2. Remove screw securing engine temperature sensor to crankcase.
3. Unhook vent hose assembly clip from inner baffle.
4. Remove screws securing outer baffles to cylinder heads and backing plate. Note location of short screws for reassembly.
5. Remove screws securing inner baffles to crankcase.

Intake Manifold Components

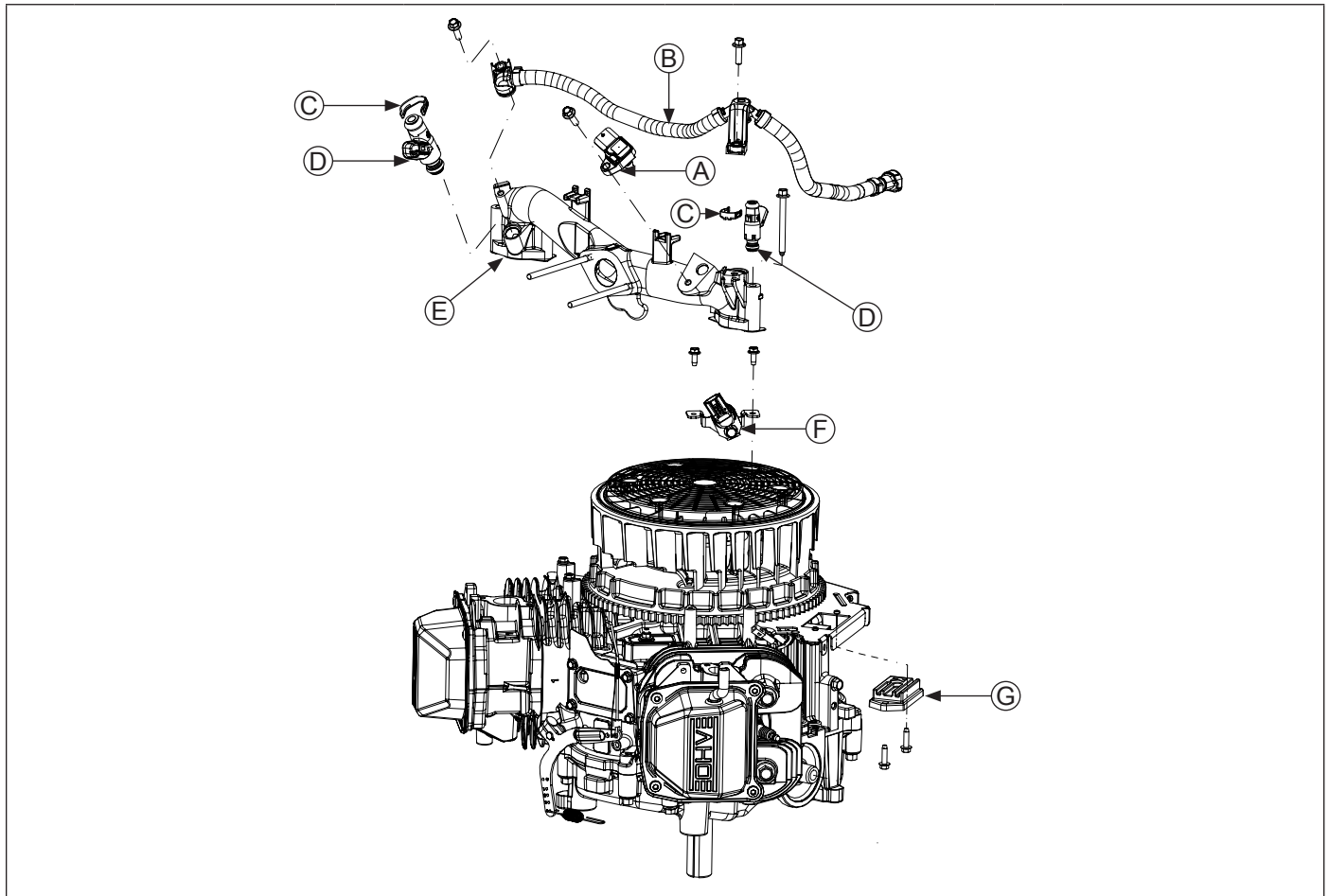

A	TMAP Sensor	B	Fuel Rail	C	Metal Retaining Clip	D	Fuel Injector
E	Intake Manifold	F	Crankshaft Position Sensor	G	Rectifier-Regulator		

Remove Crankshaft Position Sensor

1. Remove screws securing crankshaft position sensor bracket.
2. Disconnect electrical connector to crankshaft position sensor.

Remove Temperature/Manifold Absolute Pressure (TMAP) Sensor

1. With a screwdriver, slide locking tab on electrical connector.
2. Squeeze tab and detach connector.
3. Remove screw and pull TMAP sensor out of intake manifold.

Remove Fuel Injectors

NOTE: Note position of injector before removing.

1. Disconnect injector plug.
2. Remove screw and pull injector out of intake manifold for each injector.

3. When removed, pull metal retaining clip connecting fuel injector to fuel injector cap. There may be some fuel left in line. Any spilled fuel must be cleaned up immediately.

Remove Intake Manifold

1. Disconnect rectifier-regulator B+ (purple) wire from wiring harness.
2. Remove screw securing a ring terminal which is part of wiring harness.
3. Remove screws securing intake manifold to cylinder heads.
4. Remove intake manifold and intake manifold gaskets.
5. Leave wiring harness attached to manifold.

Disassembly/Inspection and Service

Cylinder Head Components

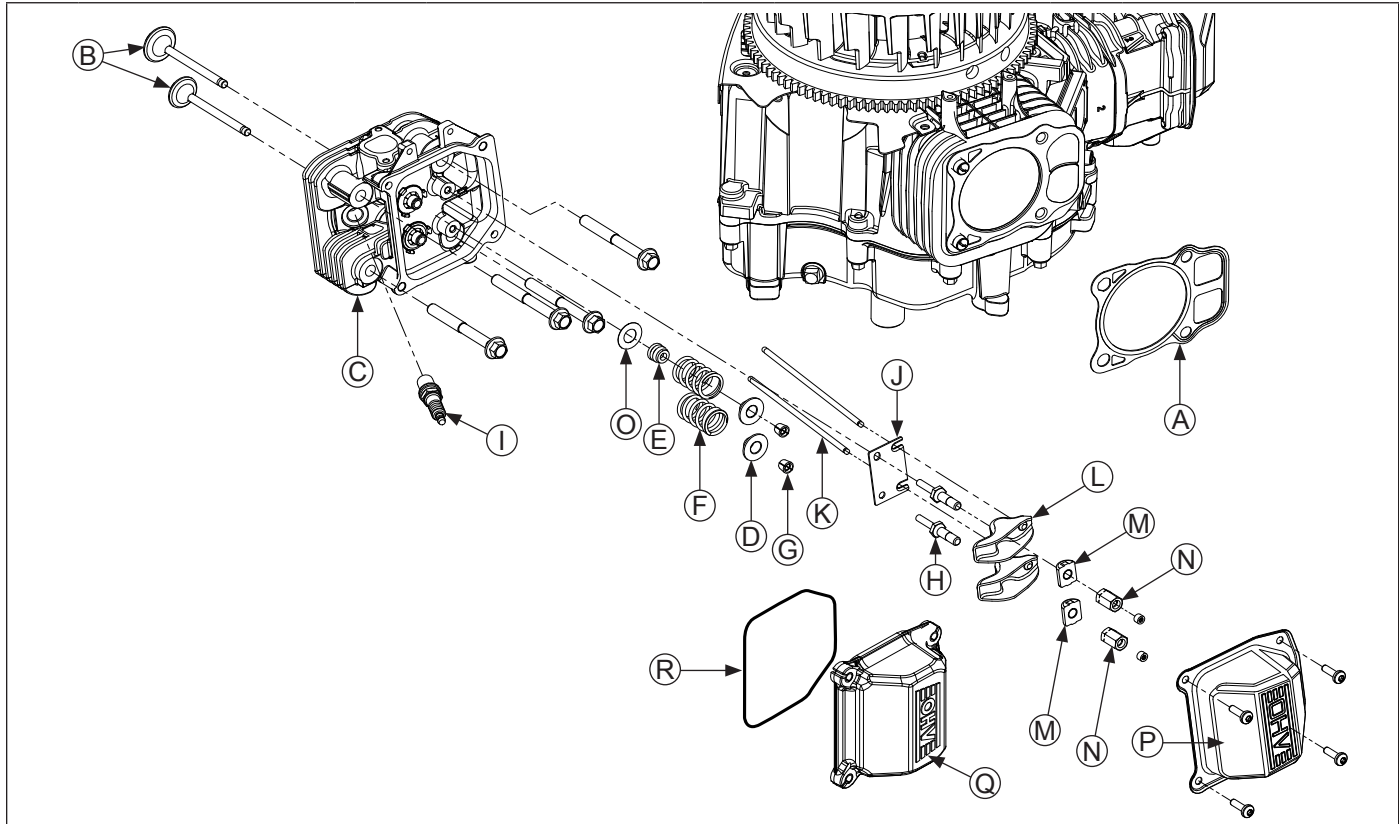

A	Gasket	B	Valve	C	Cylinder Head	D	Valve Spring Cap
E	Valve Stem Seal	F	Valve Spring	G	Valve Spring Keeper	H	Stud
I	Spark Plug	J	Guide Plate	K	Push Rod	L	Rocker Arm
M	Rocker Arm Pivots	N	Adjusters	O	Washer	P	Stamped Steel Valve Cover (RTV)
Q	Plastic Valve Cover (O-Ring)	R	O-Ring				

Remove Spark Plugs

Remove spark plug from each cylinder head.

Remove Valve Covers

Plastic Valve Covers with O-Rings

Remove screws securing each valve cover. Most valve covers have screw hole spacers molded in place. Remove valve covers and O-rings.

Stamped Steel Valve Covers with RTV Sealant

NOTE: Valve cover is sealed to cylinder head using RTV silicone sealant. When removing valve cover, use care not to damage gasket surfaces of cover and cylinder head. To break RTV seal, hold a block of wood against 1 flat face of valve cover. Strike wood firmly with a mallet. If seal doesn't break loose after 1 or 2 attempts, repeat procedure on other side.

1. Remove Torx screws securing each valve cover.
2. Using a brass wire brush and gasket remover or similar solvent, clean old RTV from surface of cylinder head and valve cover.

3. Sealing surface of stamped steel valve covers must be checked for flatness prior to reinstallation. Hold valve cover down firmly against a flat, level surface or piece of glass, and check around entire perimeter that a 0.012 in. (0.30 mm) feeler gauge cannot be inserted anywhere. If gauge goes in anywhere, cover needs to be replaced.

Remove Cylinder Heads

NOTE: Exhaust side is located on output shaft side of engine, while intake side is located on fan side of engine. Cylinder head number is embossed on outside of each cylinder head.

1. Loosen inner setscrews (T25 TORX) and back off adjusters.
2. Mark location of push rods as either intake or exhaust and cylinder 1 or 2. Push rods should always be installed in same positions.
3. Remove screws securing each cylinder head.
4. Remove cylinder head and head gasket.

Disassemble Cylinder Heads

NOTE: Use a new valve stem seal whenever valve is removed or if valve stem seal is deteriorated or damaged. Never reuse an old valve stem seal.

1. Remove adjusters, pivots, rocker arms, studs, and guide plate from cylinder head.
2. Compress valve springs using a valve spring compressor.
3. Once valve spring is compressed, remove following items.
 - Valve spring keepers.
 - Valve spring caps.
 - Valve springs.
 - Intake and exhaust valves (mark position).
 - Valve stem seal (intake valve only).
 - Washer (intake valve only).
4. Repeat above procedure for other cylinder head. Do not interchange parts from 1 cylinder head to another.

Inspection and Service Valve Details

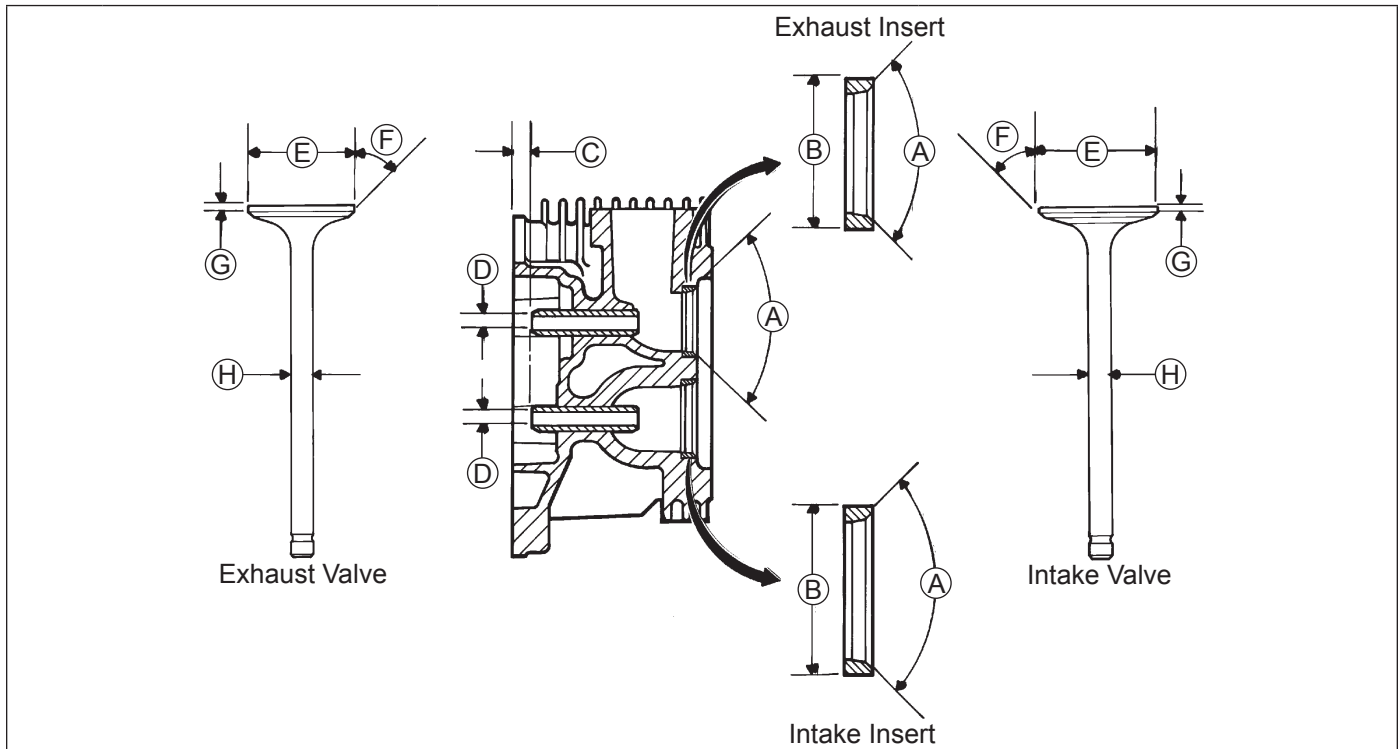

Dimension		Intake	Exhaust
A	Seat Angle	89°	89°
B	Insert O.D.	36.987/37.013 mm (1.4562/1.4572 in.)	32.987/33.013 mm (1.2987/1.2997 in.)
C	Guide Depth	4 mm (0.1575 in.)	6.5 mm (0.2559 in.)
D	Guide I.D.	7.040/7.060 mm (0.2772/0.2780 in.)	7.040/7.060 mm (0.2772/0.2780 in.)
E	Valve Head Diameter	33.37/33.63 mm (1.3138/1.3240 in.)	29.37/29.63 mm (1.1563/1.1665 in.)
F	Valve Face Angle	45°	45°
G	Valve Margin (Min.)	1.5 mm (0.0591 in.)	1.5 mm (0.0591 in.)
H	Valve Stem Diameter	6.982/7.000 mm (0.2749/0.2756 in.)	6.970/6.988 mm (0.2744/0.2751 in.)

After cleaning, check flatness of cylinder head and corresponding top surface of crankcase, using a surface plate or precision straight edge and feeler gauge. Maximum allowable out of flatness is 0.076 mm (0.003 in.).

Carefully inspect valve mechanism parts. Inspect valve springs and related hardware for excessive wear or distortion. Check valves and valve seat area or inserts for evidence of deep pitting, cracks, or distortion.

Check clearance of valve stems in guides. See valve details and specifications.

Disassembly/Inspection and Service

Hard starting, or loss of power accompanied by high fuel consumption may be symptoms of faulty valves. Although these symptoms could also be attributed to worn rings, remove and check valves first. After removal, clean valve heads, faces, and stems with a power wire brush. Then, carefully inspect each valve for defects such as warped head, excessive corrosion, or worn stem end. Replace valves found to be in bad condition.

Valve Guides

If a valve guide is worn beyond specifications, it will not guide valve in a straight line. This may result in burnt valve faces or seats, loss of compression, and excessive oil consumption.

To check valve guide-to-valve stem clearance, thoroughly clean valve guide and, using a split-ball gauge, measure inside diameter of guide. Then, using an outside micrometer, measure diameter of valve stem at several points on stem where it moves in valve guide. Use largest stem diameter to calculate clearance by subtracting stem diameter from guide diameter. If intake clearance exceeds 0.040/0.078 mm (0.0016/0.0031 in.) or exhaust clearance exceeds 0.052/0.090 mm (0.0020/0.0035 in.), determine whether valve stem or guide is responsible for excessive clearance.

Maximum (I.D.) wear on intake valve guide is 7.140 mm (0.2811 in.) while 7.160 mm (0.2819 in.) is maximum allowed on exhaust guide. Guides are not removable but can be reamed 0.25 mm (0.010 in.) oversize. Valves with 0.25 mm oversize stems must then be used.

If guides are within limits but valve stems are worn beyond limits, install new valves.

Valve Seat Inserts

Hardened steel alloy intake and exhaust valve seat inserts are press-fitted into cylinder head. Inserts are not replaceable but can be reconditioned if not too badly pitted or distorted. If cracked or badly warped, cylinder head should be replaced.

Recondition valve seat inserts following instructions provided with valve seat cutter being used. Final cut should be made with an 89° cutter as specified for valve seat angle. Cutting proper 45° valve face angle, as specified, and proper valve seat angle (44.5°, half of full 89° angle), will achieve desired 0.5° (1.0° full cut) interference angle where maximum pressure occurs on outside diameters of valve face and seat.

Lapping Valves

NOTE: Exhaust valves that are black in color cannot be ground and do not require lapping.

Reground or new valves must be lapped in, to provide fit. Use a hand valve grinder with suction cup for final lapping. Lightly coat valve face with fine grade of grinding compound, then rotate valve on seat with grinder. Continue grinding until smooth surface is obtained on seat and on valve face. Thoroughly clean cylinder head in soap and hot water to remove all traces of grinding compound. After drying cylinder head, apply a light coating of clean oil to seats and guides to prevent rusting.

Intake Valve Stem Seal

Always use a new seal when valves are removed from cylinder head. Seals should also be replaced if deteriorated or damaged in any way. Never reuse an old seal.

Remove Chopper Screen Cup and Fan (if equipped)

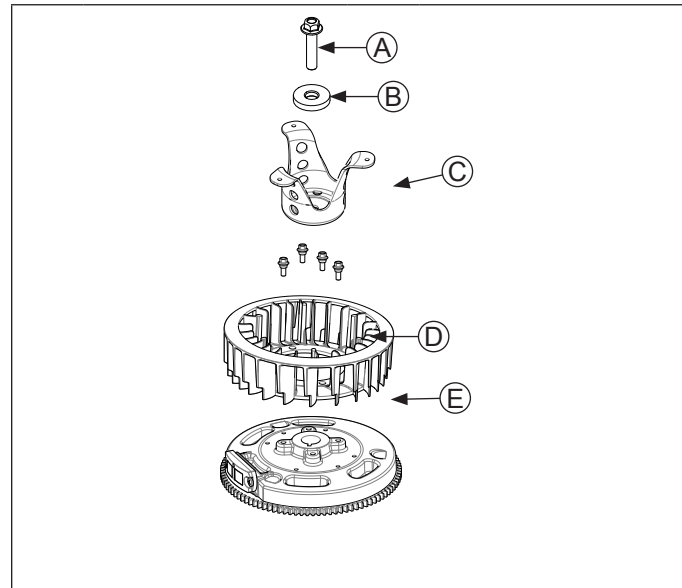

A	Flywheel Screw	B	Washer
C	Chopper Screen Cup	D	Fan Screw
E	Fan		

1. Remove flywheel screw and washer, then lift off chopper screen cup.
2. Remove screws securing fan to flywheel; remove fan.

Use procedures on next page to remove and inspect flywheel.

Flywheel/Ignition/Breather Components

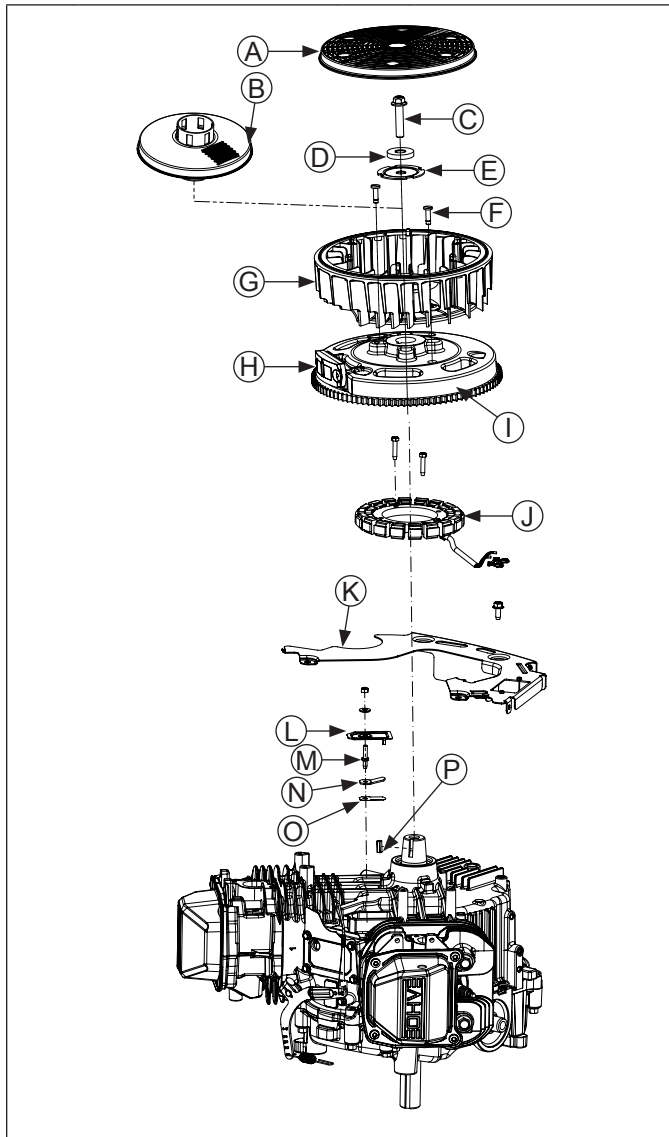

A	Debris Screen	B	Drive Cup
C	Flywheel Screw	D	Washer
E	Fan Mounting Plate	F	Retaining Screw
G	Fan	H	Magnet
I	Flywheel	J	Stator
K	Backing Plate	L	Breather Reed Cover
M	Stud	N	Retainer
O	Breather Reed	P	Flywheel Key

Remove Debris Screen, Fan, and Flywheel

NOTE: Always use a flywheel strap wrench or flywheel holding tool (see Tools and Aids) to hold flywheel when loosening or tightening flywheel and fan retaining fasteners. Do not use any type of bar or wedge between fins of cooling fan, as fins could become cracked or damaged.

NOTE: Always use a puller to remove flywheel from crankshaft. Do not strike crankshaft or flywheel, as these parts could become cracked or damaged. Striking puller or crankshaft can cause crank gear to move, affecting crankshaft endplay.

1. Unsnap debris screen (if equipped) from cooling fan.
2. Remove retaining screw, washer, and fan mounting plate or drive cup (if equipped), securing fan and flywheel to crankshaft.
3. Lift cooling fan to disengage 2 drive pins and remove it from flywheel. Two plastic retainers may remain in fan.
4. Remove flywheel from crankshaft by pulling from under ring gear with large gear puller.
5. Remove flywheel key from crankshaft.

Flywheel Inspection

Inspect flywheel for cracks, and flywheel keyway for damage. Replace flywheel if it is cracked. Replace flywheel, crankshaft, and key if flywheel key is sheared or keyway is damaged.

Inspect ring gear for cracks or damage. Rehlko does not provide ring gears as a serviceable part. Replace flywheel if ring gear is damaged.

Remove Backing Plate and Stator

1. Remove screws and backing plate from crankcase.
2. Remove screws and stator. Note routing of stator leads.

Remove Outer Breather Assembly

1. RTV sealant is used between breather reed cover and crankcase. Remove nut and sealing (flat) washer securing breather reed cover to crankcase. Carefully pry under small tab of cover flange to separate and remove. Do not bend or distort cover.
2. Unscrew and remove mounting stud, retainer and breather reed.

Disassembly/Inspection and Service

Crankshaft/Governor Gear/Oil Pump Components

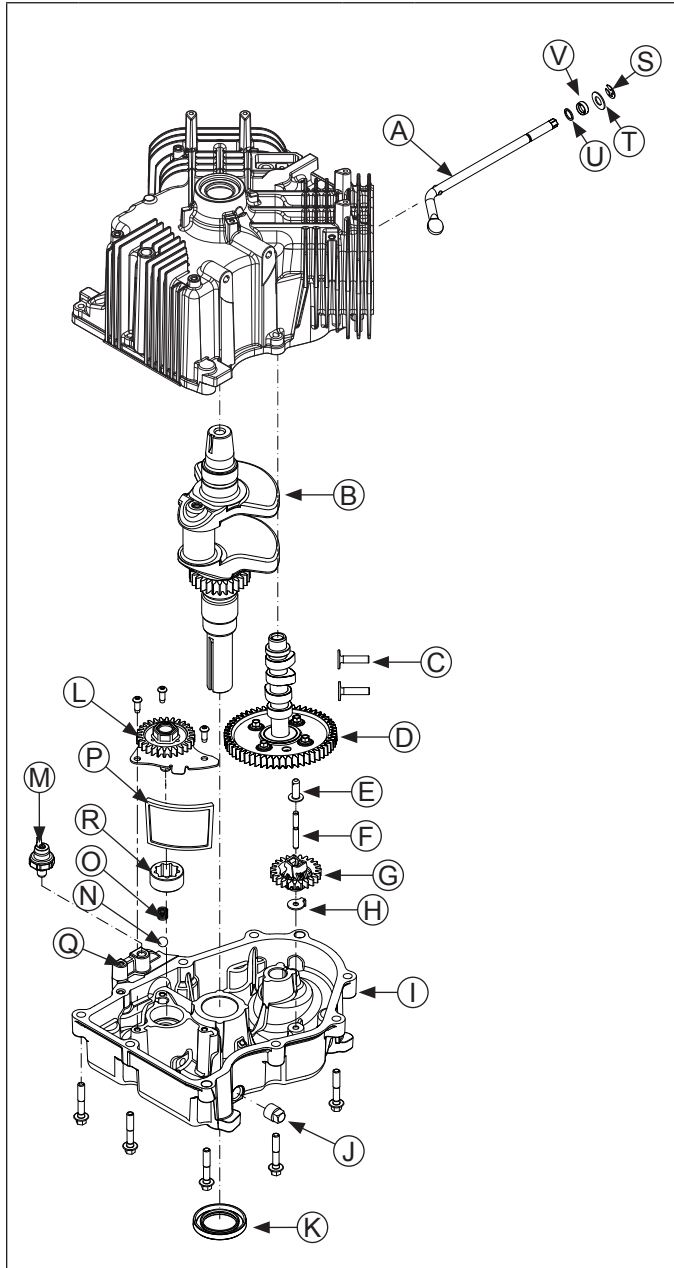

A	Governor Cross Shaft	B	Crankshaft
C	Valve Tappets	D	Camshaft
E	Regulating Pin	F	Shaft
G	Governor Gear	H	Locking Tab Thrust Washer
I	Oil Pan	J	Drain Plug
K	Oil Seal	L	Oil Pump
M	Oil Sentry™	N	Ball
O	Spring	P	Oil Pick-up Screen
Q	Ground Strap Location	R	Outer Gerotor Gear

S	E-Clip	T	Nylon Washer
U	Lower Washer	V	Cross Shaft Seal

Remove Oil Pan Assembly

1. Remove screws securing oil pan to crankcase.
2. Locate splitting tab cast into perimeter of oil pan. Insert drive end of a 1/2" breaker bar between splitting tab and crankcase and turn it to break RTV seal. Do not pry on sealing surfaces as this can cause leaks.

Inspection

Inspect oil seal in oil pan and remove it if it is worn or damaged. New oil seal is installed after oil pan is assembled to crankcase. See Reassembly, Install Oil Seal in Oil Pan.

Inspect main bearing surface for wear or damage (refer to Specifications). Replace oil pan assembly if required.

Governor Assembly

Governor gear assembly is located inside oil pan. If service is required, continue following steps.

Inspection

Inspect governor gear teeth. Replace gear if it is worn, chipped, or if any teeth are missing. Inspect governor weights. They should move freely in governor gear.

Disassembly

Governor Shaft Component and Details

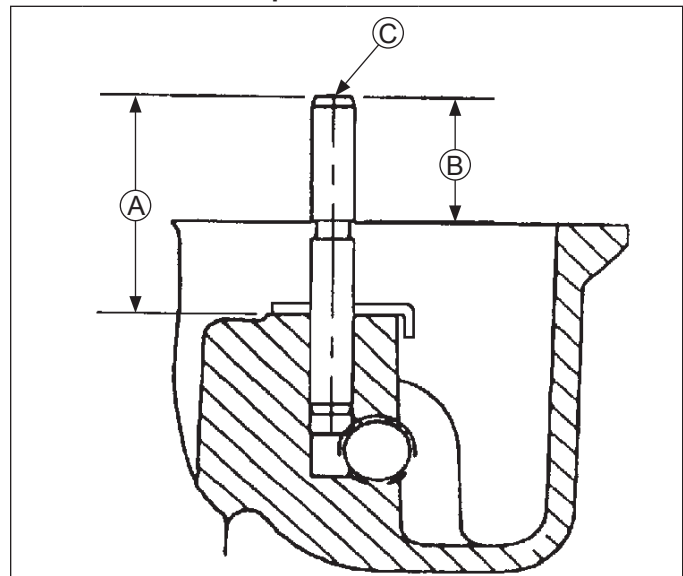

A	34.0 mm (1.3386 in.) 33.5 mm (1.3189 in.)	B	19.40 mm (0.7638 in.)
C	Gear Shaft		

NOTE: Governor gear is held onto shaft by small molded tabs in gear. When gear is removed from shaft, these tabs are destroyed and gear must be replaced. Therefore, remove gear only if absolutely necessary.

Governor gear must be replaced once it is removed from oil pan.

Disassembly/Inspection and Service

1. Use 2 small screwdrivers and carefully pry upward to remove regulating pin and governor gear assembly.
2. Remove locking tab thrust washer located under governor assembly.
3. Carefully inspect governor gear shaft and replace it only if it is damaged. After removing damaged shaft, press or lightly tap replacement shaft into oil pan to depth shown.

Reassembly

1. Install locking tab thrust washer on governor gear shaft with tab down.
2. Position regulating pin within governor gear/flyweights assembly and slide both onto governor shaft until assembly locks into place.

Oil Pump Assembly

Oil pump is mounted inside oil pan. If service is required, continue with Disassembly, Inspection, and Reassembly.

Disassembly

1. Remove screws.
2. Lift oil pump assembly from oil pan. Remove outer gerotor gear from oil pan.
3. Ensure ball and spring remain installed in pressure relief hole of oil pan. If ball and spring fall out of pressure relief hole, see reassembly for correct installation.

Inspection

Inspect oil pump housing, gear, and rotors for nicks, burrs, wear, or any visible damage. If any parts are worn or damaged, replace oil pump assembly. Check oil pickup screen for damage or restriction, replace if necessary. Disassembly of oil pump is not recommended.

Reassembly

1. Lubricate outer gerotor gear with oil. Install outer gerotor gear through shaft of oil pump, around inner gerotor gear. Matching molding dots on inner and outer gerotor gears is not necessary and will not affect oil pump efficiency.
2. Reinstall ball, then spring into pressure relief hole of oil pan.
3. Install oil pump inserting center shaft into corresponding recess in oil pan. Secure oil pump by torquing screws (in no specific sequence) to 9.9 N·m (88 in. lb.).
4. After torquing, rotate gear and check for freedom of movement. Make sure there is no binding. If binding occurs, loosen screws, reposition pump, retorque screws and recheck movement.

Remove Camshaft and Valve Tappets

1. Position crankcase so flywheel side is down. Remove camshaft.
2. Remove valve tappets from crankcase and mark them by their location, as either intake or exhaust and cylinder 1 or 2. Tappets should always be reinstalled in same position.

Camshaft Inspection and Service

Check lobes of camshaft for wear or damage. See Specifications for minimum lift specifications. Inspect cam gear for badly worn, chipped or missing teeth. Replacement of camshaft will be necessary if any of these conditions exist.

Valve Tappets Inspection

Check base surface of valve tappet(s) for wear or damage. Replace tappet(s) if condition is questionable in any way. Corresponding camshaft lobe(s) should also be checked for wear or damage. Whenever tappets are replaced, apply a liberal coating of Rehlko lubricant to base of each new tappet before it is installed.

Remove Governor Cross Shaft

Governor Cross Shaft Oil Seal Details

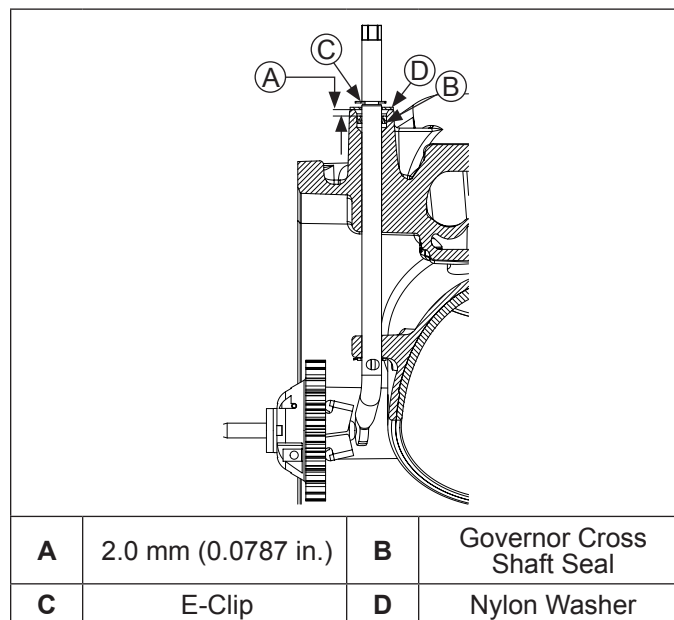

1. Remove E-clip and nylon washer from governor cross shaft.
2. Remove cross shaft with lower washer through inside of crankcase.
3. Remove governor shaft seal from crankcase.

If governor cross shaft seal is damaged and/or leaks, replace it using following procedure.

Remove oil seal from crankcase and replace it with a new one. Install new seal to depth shown.

Disassembly/Inspection and Service

Connecting Rods/Piston/Breather Components

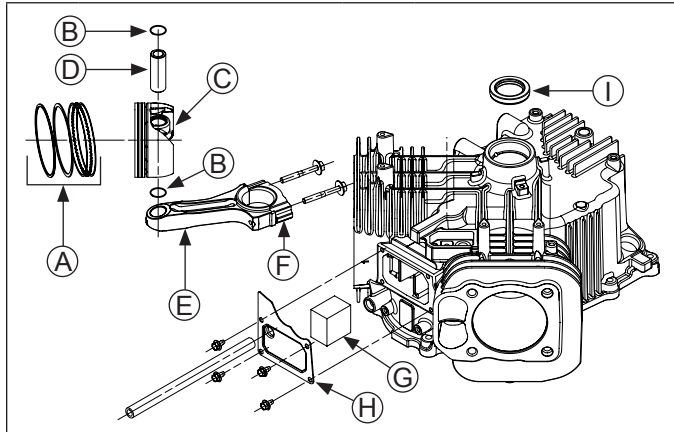

A	Piston Ring Set	B	Piston Pin Retainer
C	Piston	D	Piston Pin
E	Connecting Rod	F	Connecting Rod End Cap
G	Breather Filter	H	Breather Cover
I	Oil Seal		

Remove Breather Assembly

Breather system is designed to control amount of oil in head area and still maintain necessary vacuum in crankcase.

When pistons move downward, crankcase gases are pushed past reed through breather filter into intake system. Upward travel of pistons closes reed and creates a low vacuum in lower crankcase. Any oil separated out through filter drains back into crankcase.

1. Remove screws securing breather cover to crankcase.
2. Using a pry tool, carefully remove cover and breather filter. Use care not to damage sealing surfaces. If cover is warped, replacement is required. Make sure drain back hole is not plugged or restricted.

Remove Connecting Rods with Pistons and Rings

NOTE: If a carbon ridge is present at top of either cylinder bore, use a ridge reamer tool to remove it before attempting to remove piston.

NOTE: Cylinders are numbered on crankcase. Use numbers to mark each end cap, connecting rod and piston for reassembly. Do not mix end caps and connecting rods.

1. Remove screws securing closest connecting rod end cap. Remove end cap.
2. Carefully remove connecting rod and piston assembly from cylinder bore.
3. Repeat above procedure for other connecting rod and piston assembly.

Connecting Rods

Offset, stepped-cap connecting rods are used in all these engines.

Inspection and Service

Check bearing area (big end) for excessive wear, score marks, running and side clearances (See Specifications). Replace rod and cap if scored or excessively worn.

Service replacement connecting rods are available in STD size and 0.25 mm (0.010 in.) undersize. Undersized rods, 0.25 mm (0.010 in.), have an identification marking on lower end of rod shank. Always refer to appropriate parts information to ensure correct replacements are used.

Piston and Rings

Inspection

Piston and Rings Components and Details

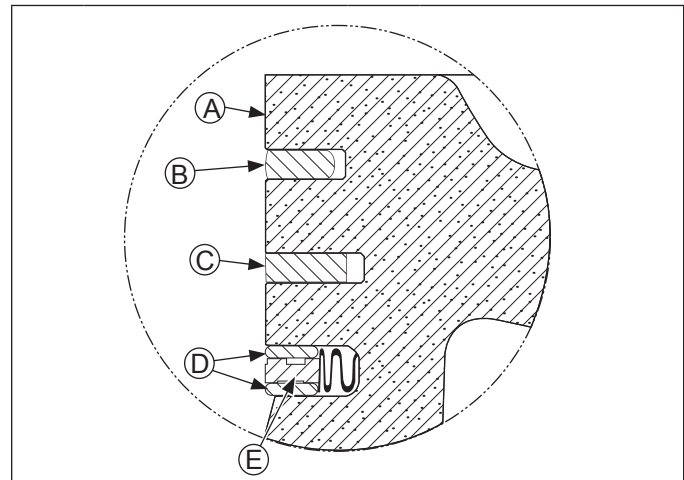

A	Piston	B	Top Compression Ring
C	Middle Compression Ring	D	Rails
E	Expander		

Scuffing and scoring of pistons and cylinder walls occurs when internal engine temperatures approach welding point of piston. Temperatures high enough to do this are created by friction, which is usually attributed to improper lubrication and/or overheating of engine.

Normally, very little wear takes place in piston boss-piston pin area. If original piston and connecting rod can be reused after new rings are installed, original pin can also be reused but new piston pin retainers are required. A piston pin is included as part of piston assembly – if pin boss in piston or pin are worn or damaged, a new piston assembly is required.

Ring failure is usually indicated by excessive oil consumption and blue exhaust smoke. When rings fail, oil is allowed to enter combustion chamber where it is burned along with fuel. High oil consumption can also occur when piston ring end gap is incorrect because ring cannot properly conform to cylinder wall under this condition. Oil control is also lost when ring gaps are not staggered during installation.

When cylinder temperatures get too high, lacquer and varnish collect on pistons causing rings to stick, which results in rapid wear. A worn ring usually takes on a shiny or bright appearance.

Scratches on rings and pistons are caused by abrasive material such as carbon, dirt, or pieces of hard metal.

Detonation damage occurs when a portion of fuel charge ignites spontaneously from heat and pressure shortly after ignition. This creates 2 flame fronts, which meet and explode to create extreme hammering pressures on a specific area of piston. Detonation generally occurs from using low octane fuels.

Pre-ignition or ignition of fuel charge before timed spark can cause damage similar to detonation. Pre-ignition damage is often more severe than detonation damage. Pre-ignition is caused by a hot spot in combustion chamber such as glowing carbon deposits, blocked cooling fins, an improperly seated valve, or wrong spark plug(s).

Replacement pistons are available in STD bore size, and 0.25 mm (0.010 in.) oversize. Replacement pistons include new piston ring sets and new piston pins.

Replacement ring sets are also available separately for STD, and 0.25 mm (0.010 in.) oversize pistons. Always use new piston rings when installing pistons. Never use old rings.

Some important points to remember when servicing piston rings:

1. Cylinder bore must be de-glazed before service ring sets are used.
2. If cylinder bore does not need re-boring and if old piston is within wear limits and free of score or scuff marks, old piston may be reused.
3. Remove old rings and clean up grooves. Never reuse old rings.
4. Before installing new rings on piston, place top 2 rings, each in turn, in its running area in cylinder bore and check end gap. Top compression ring end gap clearance is 0.189/0.277 mm (0.0074/0.0109 in.) for a new bore, or 0.531 mm (0.0209 in.) for a used bore. Middle compression ring end cap is 1.519/1.797 mm (0.0598/0.0708 in.) for a new bore, or 2.051 mm (0.0808 in.) for a used bore.
5. After installing new compression (top and middle) rings on piston, make sure top compression ring-to-groove side clearance and is 0.030/0.070 mm (0.0010/0.0026 in.) and middle compression ring-to-groove side clearance 0.030/0.070 mm (0.0010/0.026 in.). If side clearance is greater than specified, a new piston must be used.

Install New Piston Rings Piston Ring Orientation

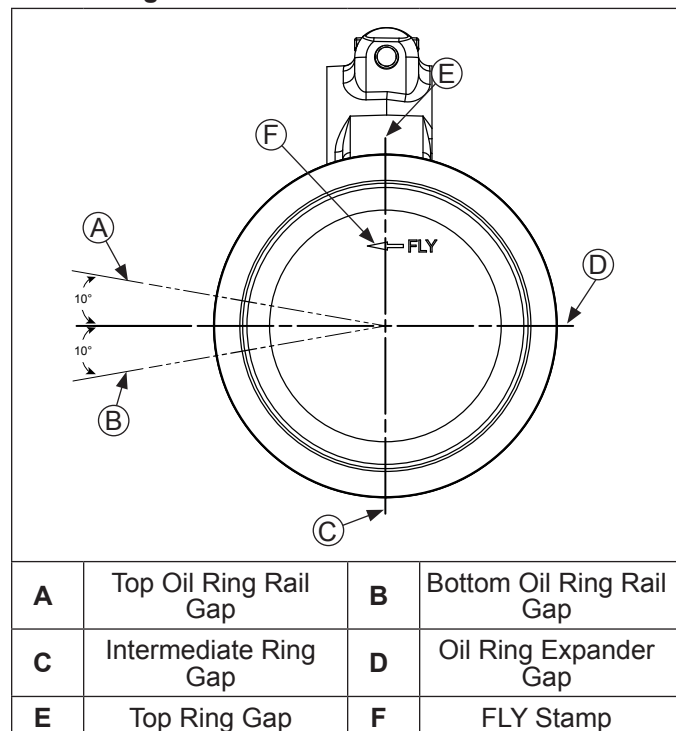

NOTE: Rings must be installed correctly. Ring installation instructions are usually included with new ring sets. Follow instructions carefully. Use a piston ring expander to install rings. Install bottom (oil control) ring first and top compression ring last.

To install new piston rings, proceed as follows:

1. Oil control ring (bottom groove): Install expander and then rails. Make sure ends of expander are not overlapped.
2. Middle compression ring (center groove): Install center ring using a piston ring installation tool. Make sure identification mark is up or colored dye stripe (if contained), is to left of end gap.
3. Top compression ring (top groove): Install top ring using a piston ring expander. Make sure identification mark is up or colored dye stripe (if contained), is to left of end gap.

Disassembly/Inspection and Service

Remove Crankshaft

Carefully pull crankshaft from crankcase.

Inspection and Service

Inspect gear teeth of crankshaft. If teeth are badly worn, chipped, or some are missing, replacement of crankshaft will be necessary.

Inspect crankshaft bearing surfaces for scoring, grooving, etc. Measure running clearance between crankshaft journals and their respective bearing bores. Use an inside micrometer or telescoping gauge to measure inside diameter of both bearing bores in vertical and horizontal planes. Use an outside micrometer to measure outside diameter of crankshaft main bearing journals. Subtract journal diameters from their respective bore diameters to get running clearances. Check results against values in Specifications. If running clearances are within specification, and there is no evidence of scoring, grooving, etc., no further reconditioning is necessary. If bearing surfaces are worn or damaged, crankcase and/or oil pan will need to be replaced.

Inspect crankshaft keyways. If worn or chipped, replacement of crankshaft will be necessary.

Inspect crankpin for score marks or metal transfer. Slight score marks can be cleaned with crocus cloth soaked in oil. If wear limits are exceeded, as stated in Specifications, it will be necessary to either replace crankshaft or regrind crankpin to 0.25 mm (0.010 in.) undersize. If reground, a 0.25 mm (0.010 in.) undersize connecting rod (big end) must then be used to achieve proper running clearance. Measure crankpin for size, taper, and out-of-round.

Remove Flywheel and PTO End Oil Seals

Remove oil seals from crankcase and oil pan.

Crankcase

Inspection and Service

Check all gasket surfaces to make sure they are free of gasket fragments. Gasket surfaces must also be free of deep scratches or nicks.

Check cylinder bore for scoring. In severe cases, unburned fuel can cause scuffing and scoring of cylinder wall. It washes necessary lubricating oils off piston and cylinder wall. As raw fuel seeps down cylinder wall, piston rings make metal to metal contact with wall. Scoring of cylinder wall can also be caused by localized hot spots resulting from blocked cooling fins or from inadequate or contaminated lubrication.

If cylinder bore is badly scored, excessively worn, tapered, or out-of-round, resizing is necessary. Use an inside micrometer to determine amount of wear (refer to Specifications). A 0.25 mm (0.010 in.) oversize piston is available if resizing is selected. Initially, resize using a boring bar, then use these following procedures for honing cylinder.

Honing

Details

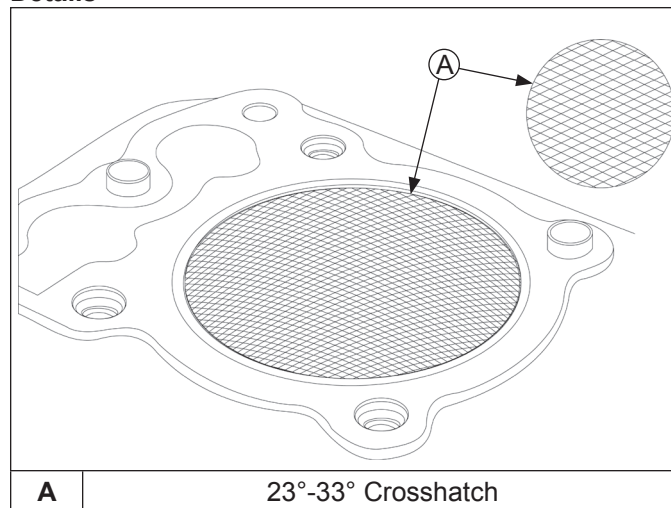

NOTE: Rehlko pistons are custom-machined to exacting tolerances. When over-sizing a cylinder, it should be machined exactly 0.25 mm (0.010 in.) over new diameter (refer to Specifications). Oversize Rehlko replacement piston will then fit correctly.

While most commercially available cylinder hones can be used with either portable drills or drill presses, use of a low speed drill press is preferred as it facilitates more accurate alignment of bore in relation to crankshaft crossbore. Honing is best accomplished at a drill speed of about 250 RPM and 60 strokes per minute. After installing coarse stones in hone, proceed as follows:

1. Lower hone into bore and after centering, adjust so stones are in contact with cylinder wall. Use of a commercial cutting-cooling agent is recommended.
2. With lower edge of each stone positioned even with lowest edge of bore, start drill and honing process. Move hone up and down while resizing to prevent formation of cutting ridges. Check size frequently.
3. When bore is within 0.064 mm (0.0025 in.) of desired size, remove coarse stones and replace them with burnishing stones. Continue with burnishing stones until bore is within 0.013 mm (0.0005 in.) of desired size and then use finish stones (220-280 grit) and polish bore to its final size. A crosshatch should be observed if honing is done correctly. Crosshatch should intersect at approximately 23°-33° off horizontal. Too flat an angle could cause rings to skip and wear excessively, and too steep an angle will result in high oil consumption.
4. After resizing, check bore for roundness, taper, and size. Use an inside micrometer, telescoping gauge, or bore gauge to take measurements. These measurements should be taken at 3 locations in cylinder – at top, middle, and bottom. Two measurements should be taken (perpendicular to each other) at 3 locations.

Clean Cylinder Bore After Honing

Proper cleaning of cylinder walls following boring and/or honing is very critical to a successful overhaul. Machining grit left in cylinder bore can destroy an engine in less than 1 hour of operation after a rebuild.

Final cleaning operation should always be a thorough scrubbing with a brush and hot, soapy water. Use a strong detergent capable of breaking down machining oil while maintaining a good level of suds. If suds break down during cleaning, discard dirty water and start again with more hot water and detergent. Following scrubbing, rinse cylinder with very hot, clear water, dry it completely, and apply a light coating of engine oil to prevent rusting.

Measuring Piston-to-Bore Clearance

Piston Detail

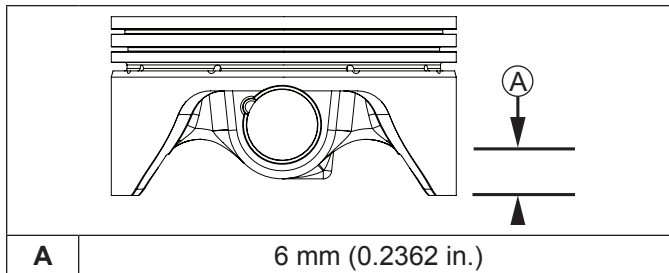

NOTE: Do not use a feeler gauge to measure piston-to-bore clearance, it will yield inaccurate measurements. Always use a micrometer.

Before installing piston into cylinder bore, it is necessary that clearance be accurately checked. This step is often overlooked, and if clearances are not within specifications, engine failure will usually result.

Use following procedure to accurately measure piston-to-bore clearance:

1. Use a micrometer and measure diameter of piston 6 mm (0.2362 in.) above bottom of piston skirt and perpendicular to piston pin.
2. Use an inside micrometer, telescoping gauge, or bore gauge and measure cylinder bore. Measurement approximately 63.5 mm (2.5 in.) below top of bore and perpendicular to piston pin.
3. Piston-to-bore clearance is difference between bore diameter and piston diameter (step 2 minus step 1).

Reassembly

NOTE: Make sure engine is assembled using all specified torque values, tightening sequences, and clearances. Failure to observe specifications could cause severe engine wear or damage. Always use new gaskets.

Make sure all traces of any cleaner are removed before engine is assembled and placed into operation. Even small amounts of these cleaners can quickly break down lubricating properties of engine oil.

Check oil pan, crankcase, cylinder heads, breather covers, and valve covers to be certain all old sealing material has been removed. Use gasket remover, lacquer thinner, or paint remover to remove any remaining traces. Clean surfaces with isopropyl alcohol, acetone, lacquer thinner, or electrical contact cleaner.

Connecting Rods/Piston/Breather Components

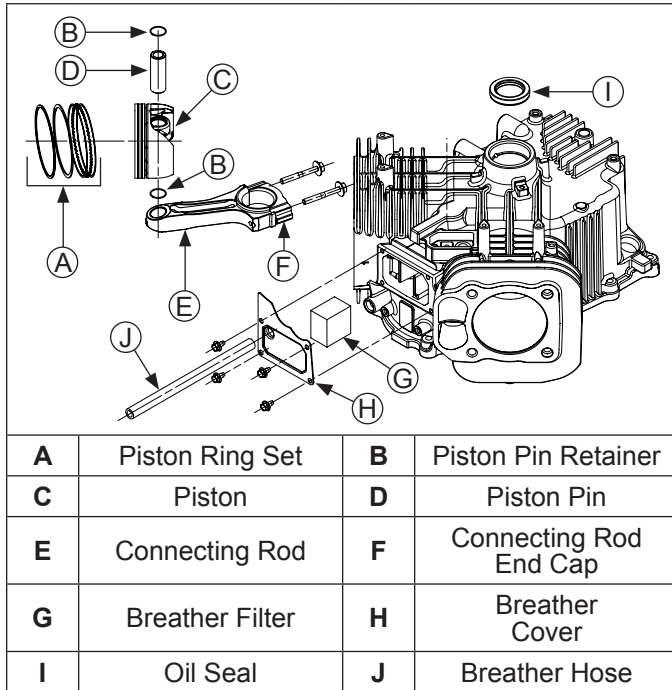

Install Flywheel End Oil Seal

1. Make sure seal bore of crankcase is clean and free of any nicks or burrs.
2. Apply a light coat of engine oil to outside diameter of oil seal.
3. Install oil seal into crankcase using a seal driver. Make sure oil seal is installed straight and true in bore and tool bottoms against crankcase.

Install Breather Filter and Inner Cover

Fastener Torque Sequence and Sealant

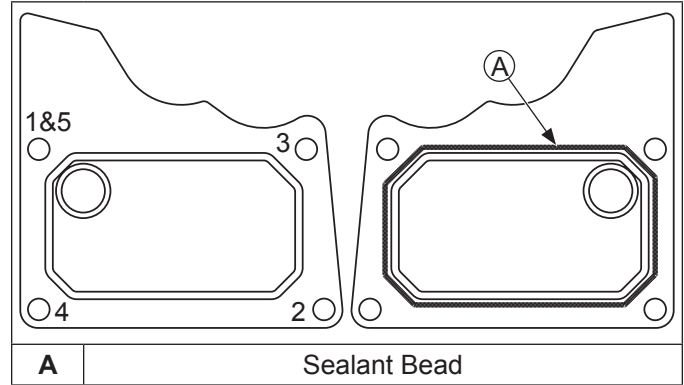

NOTE: Always use fresh sealant. Using outdated sealant can result in leakage. Refer to Tools and Aids for a listing of approved sealants.

NOTE: To ensure proper adhesion of sealant to both sealing surfaces, perform step 4 immediately (5 minutes maximum) after application of RTV.

NOTE: RTV sealant should be allowed to cure a minimum of 1 hour before engine is started.

1. Install breather filter between 2 ribs inside breather chamber.
2. Make sure sealing surfaces are clean and free of nicks or damage.
3. Apply a 1.5 mm (1/16 in.) bead of RTV sealant to sealing surface of breather cover. See sealant pattern.
4. Immediately install cover onto crankcase. Do not allow RTV sealant to come into contact with any other components.
5. Secure breather cover with M5 screws. Torque screws in sequence shown to 6.2 N·m (55 in. lb.) into a new, cored hole, or 4.0 N·m (35 in. lb.) into a used hole.
6. Attach breather hose if disconnected earlier.

Crankshaft/Governor Gear/Oil Pump Components

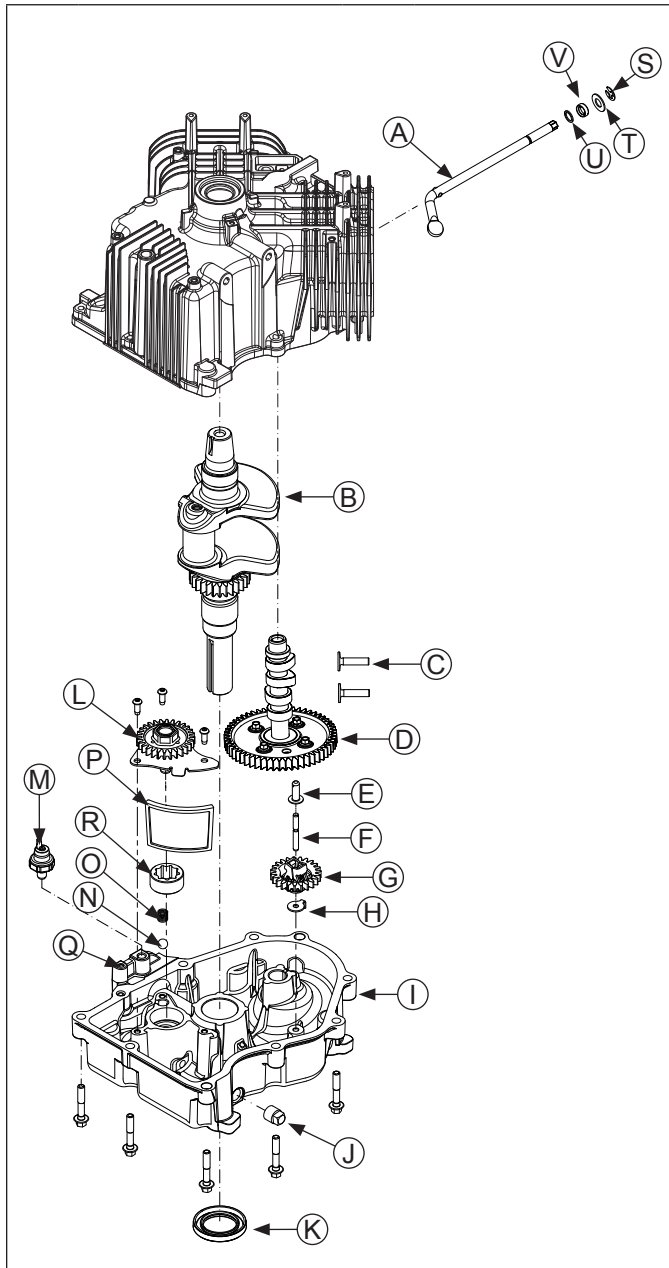

A	Governor Cross Shaft	B	Crankshaft
C	Valve Tappets	D	Camshaft
E	Regulating Pin	F	Shaft
G	Governor Gear	H	Locking Tab Thrust Washer
I	Oil Pan	J	Drain Plug
K	Oil Seal	L	Oil Pump
M	Oil Sentry™	N	Ball
O	Spring	P	Oil Pick-up Screen
Q	Ground Strap Location	R	Outer Gerotor Gear

S	E-Clip	T	Nylon Washer
U	Lower Washer	V	Cross Shaft Seal

Install Governor Cross Shaft

NOTE: If governor cross shaft seal was removed, see Disassembly/Inspection and Service procedure to install seal.

1. Lubricate governor cross shaft bearing surfaces in crankcase with engine oil.
2. Slide lower washer onto governor cross shaft and install cross shaft from inside of crankcase.
3. Install nylon washer onto governor cross shaft. Install E-clip into groove on cross shaft. Use a 0.25 mm (0.010 in.) feeler gauge to make sure gap between washer and clip is at least 0.25 mm (0.010 in.).

Install Crankshaft

1. Lubricate flywheel side main bearing surface and lips of oil seal in crankcase with clean engine oil.
2. Carefully slide flywheel end of crankshaft through main bearing in crankcase.

Install Connecting Rods with Pistons and Rings

Piston and Connecting Rod Details

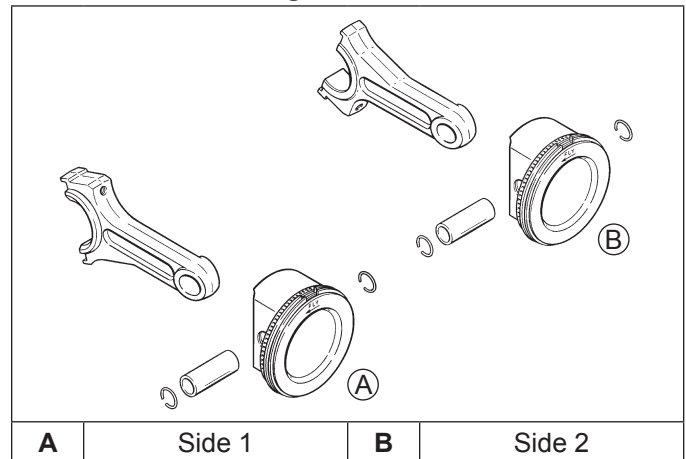

NOTE: Cylinders are numbered on crankcase. Make sure to install piston, connecting rod, and end cap into its appropriate cylinder bore as previously marked during disassembly. Do not mix end caps and connecting rods.

NOTE: Proper orientation of piston/connecting rod assemblies inside engine is extremely important. Improper orientation can cause extensive wear or damage. Be certain pistons and connecting rods are assembled exactly as shown.

NOTE: Align chamfer of connecting rod with chamfer of its mating end cap. When installed, flat faces of connecting rods should face each other. Faces with raised rib should be toward outside.

1. If piston rings were removed, see Disassembly/Inspection and Service procedure to install rings.
2. Lubricate cylinder bore, piston, and piston rings with engine oil. Compress rings using a piston ring compressor.

Reassembly

- Lubricate crankshaft journals and connecting rod bearing surfaces with engine oil.
- Make sure FLY stamping on piston is facing toward flywheel side of engine. Use a hammer with a rubber or wood grip and gently tap piston into cylinder. Be careful oil ring rails do not spring free between bottom of ring compressor and top of cylinder.
- Install inner rod cap to connecting rod using screws and torque in increments to 13.6 N·m (120 in. lb.). Illustrated instructions are provided in service rod package.
- Repeat above procedure for other connecting rod and piston assembly.

Install Valve Tappets and Camshaft

Timing Mark Detail

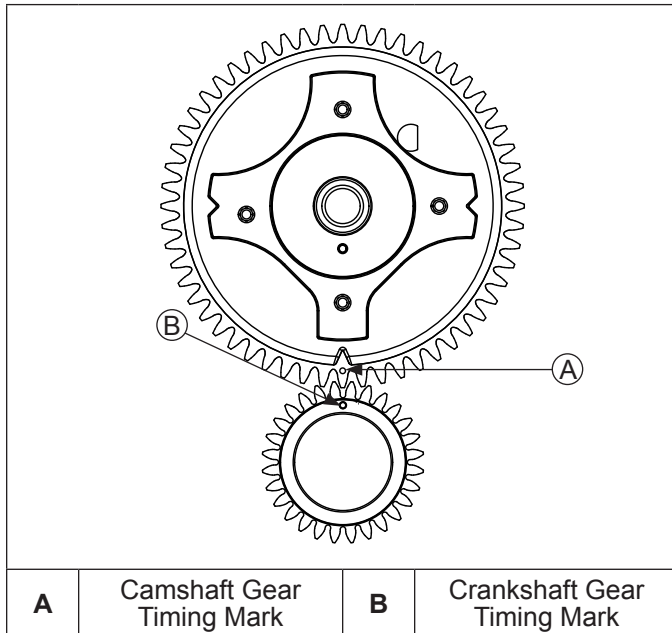

NOTE: Exhaust valve tappets are located on output shaft side of engine, while intake valve tappets are located on fan side of engine. Cylinder number is embossed on outside of each cylinder on crankcase. Valve tappets should always be installed in same position as before disassembly.

- Apply camshaft lubricant to contact surface of valve tappets. Note mark or tag identifying tappets and install them in their appropriate crankcase locations. A small amount of grease applied to stems will hold valve tappets up until camshaft is installed.
- Liberally apply camshaft lubricant to lobes of camshaft. Lubricate camshaft bearing surfaces of crankcase and camshaft with engine oil.
- Position timing mark of crankshaft gear at 12 o'clock position.
- Turn governor cross shaft clockwise until lower end (blade) is laying against bottom of cylinder. Make sure cross shaft remains in this position while installing camshaft.

- Slide camshaft into bearing surface of crankcase, positioning timing mark of camshaft gear at 6 o'clock position. Make sure camshaft gear and crankshaft gear mesh with both timing marks aligned.

Oil Pump Assembly

Oil pump is mounted inside oil pan. If service was required and oil pump was removed, refer to Disassembly/Inspection and Service procedure.

Governor Assembly

Governor assembly is located inside oil pan. If service was required and governor was removed, refer to Disassembly/Inspection and Service procedure.

Install Oil Seal in Oil Pan

Oil Seal Component and Detail

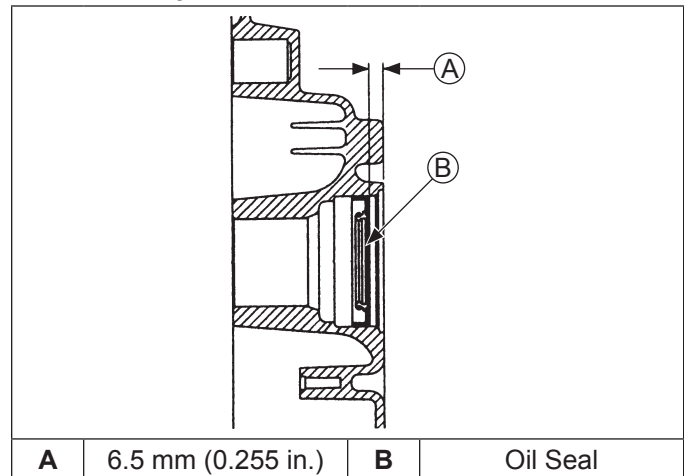

- Check to make sure there are no nicks or burrs in crankshaft bore of oil pan.
- Apply a light coat of engine oil to outside diameter of oil seal.
- Drive oil seal into oil pan using a seal driver. Make sure oil seal is installed straight and true in bore, to depth shown.

Install Oil Pan Assembly

Sealant Pattern

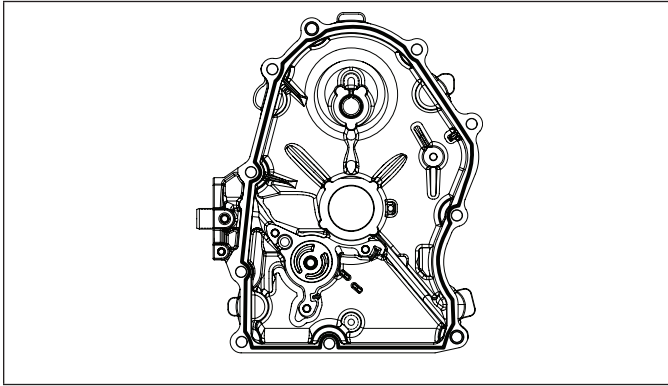

Fastener Torque Sequence

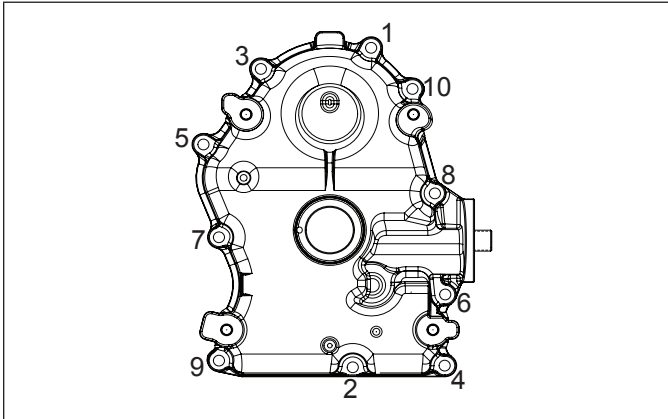

RTV sealant is used as a gasket between oil pan and crankcase. Refer to Tools and Aids for a listing of approved sealants. Always use fresh sealant. Using outdated sealant can result in leakage.

1. Be sure sealing surfaces have been cleaned and prepared as described at beginning of Reassembly.
2. Check to make sure there are no nicks or burrs on sealing surfaces of oil pan or crankcase.
3. Apply a 1.5 mm (1/16 in.) bead of black RTV sealant to sealing surface of oil pan. See sealant pattern. Oil pan must be installed within 5 minutes of sealant being applied for proper sealing to occur.
4. Make sure end of governor cross shaft is lying against bottom of cylinder inside crankcase.
5. Install oil pan to crankcase. Carefully seat camshaft and crankshaft into their mating bearings. Rotate crankshaft to help engage oil pump and governor gear meshes.
6. Install 10 screws securing oil pan to crankcase. Torque fasteners in sequence shown to 25.7 N·m (227 in. lb.).

Flywheel/Ignition/Breather Components

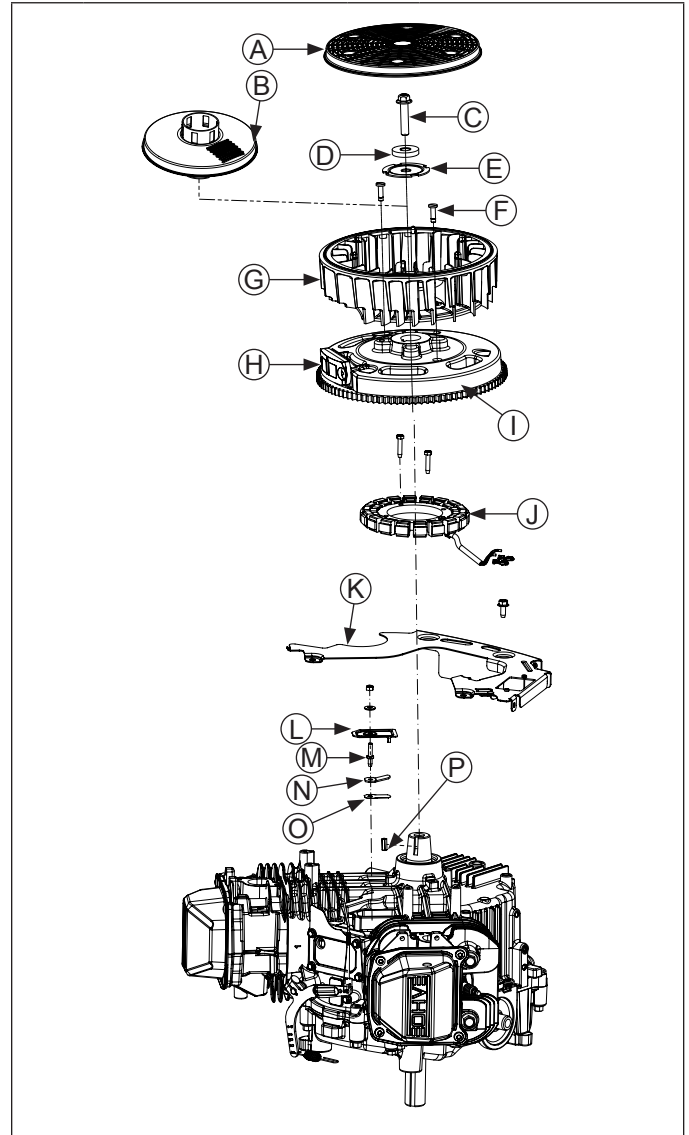

A	Debris Screen	B	Drive Cup
C	Flywheel Screw	D	Washer
E	Fan Mounting Plate	F	Retaining Screw
G	Fan	H	Magnet
I	Flywheel	J	Stator
K	Backing Plate	L	Breather Reed Cover
M	Stud	N	Retainer
O	Breather Reed	P	Flywheel Key

Reassembly

Install Breather Reed and Outer Cover

Breather Cover Sealant

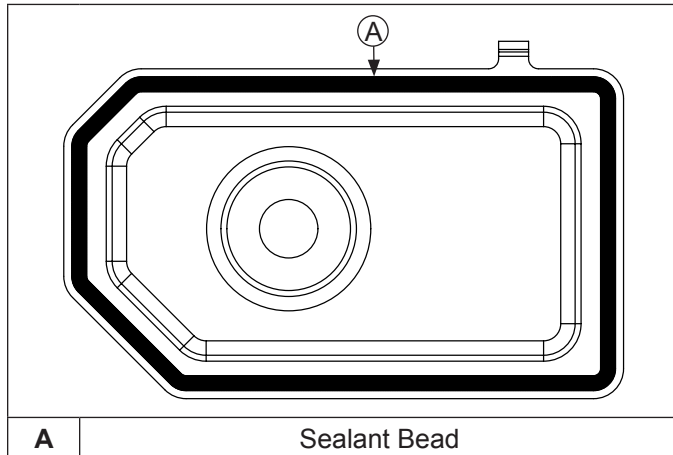

NOTE: RTV sealant should be allowed to cure a minimum of 1 hour before engine is started.

1. Install breather reed, followed by retainer over passage hole and mounting hole in crankcase. Hold in position and secure with mounting stud. Torque stud to 6.2 N·m (55 in. lb.) into a new, cored hole, or 4.0 N·m (35 in. lb.) into a used hole.
2. Invert breather reed cover and apply a 1.5 mm (1/16 in.) bead of RTV sealant to perimeter flange of cover as shown. Use Loctite® 5900™ or 5910™.
3. Immediately install breather reed cover over mounting stud and onto crankcase. Do not allow RTV sealant to come in contact with breather reed, or reed sealing surface.
4. Secure with a new sealing washer and M5 nut. Torque nut to 1.3 N·m (12 in. lb.). Check that a complete seal has occurred by RTV sealant being squeezed out around entire flange perimeter.

Install Stator and Backing Plate

Backing Plate Torque Sequence

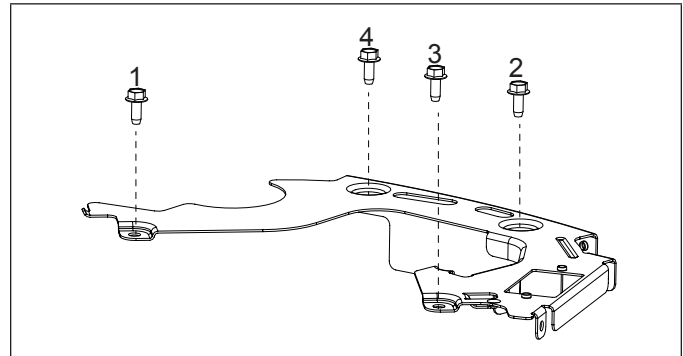

1. Apply pipe sealant with Teflon® (Loctite® PST® 592™ or equivalent) to stator mounting holes.
2. Position stator aligning mounting holes so leads are at bottom, toward crankcase.
3. Install and torque screws to 8.8 N·m (78 in. lb.).
4. Install backing plate. Secure with screws. Torque screws to 7.3 N·m (65 in. lb.) in sequence shown.

Install Flywheel, Fan and Debris Screen



⚠ CAUTION

Damaging Crankshaft and Flywheel can cause personal injury.

Using improper procedures can lead to broken fragments. Broken fragments could be thrown from engine. Always observe and use precautions and procedures when installing flywheel.

NOTE: Before installing flywheel, make sure crankshaft taper and flywheel hub are clean, dry, and completely free of lubricants. Presence of lubricants can cause flywheel to be overstressed and damaged when screw is torqued to specifications.

NOTE: Make sure flywheel key is installed properly in keyway. Flywheel can become cracked or damaged if key is not installed properly.

1. Install flywheel key into keyway of crankshaft. Make sure key is properly seated and parallel with shaft taper.
2. Install flywheel onto crankshaft being careful not to shift flywheel key.
3. Install fan onto flywheel, so locating pins fit into corresponding recesses. Drive 2 retainers down completely.
4. Install fan mounting plate or drive cup (if equipped) onto fan, aligning 4 cutouts, followed by heavy flat washer and screw.
5. Use a flywheel strap wrench or holding tool to hold flywheel. Torque screw securing flywheel to crankshaft to 74.5 N·m (55 ft. lb.).
6. Snap debris screen into place onto cooling fan.

Install Chopper Screen Cup and Fan (if equipped)

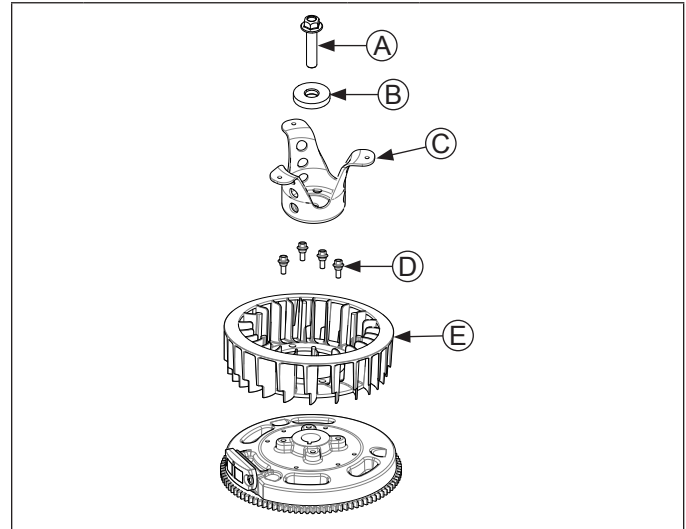

A	Flywheel Screw	B	Washer
C	Chopper Screen Cup	D	Fan Screw
E	Fan		

1. Install fan onto flywheel, so locating pins fit into corresponding recesses. Install fan screws and torque to 10.0 N·m (88 in. lb.).
1. Install chopper screen cup, washer, and flywheel screw. Use a flywheel strap wrench or holding tool to hold flywheel. Torque screw securing flywheel to crankshaft to 74.5 N·m (55 ft. lb.).

Reassembly

Cylinder Head Components

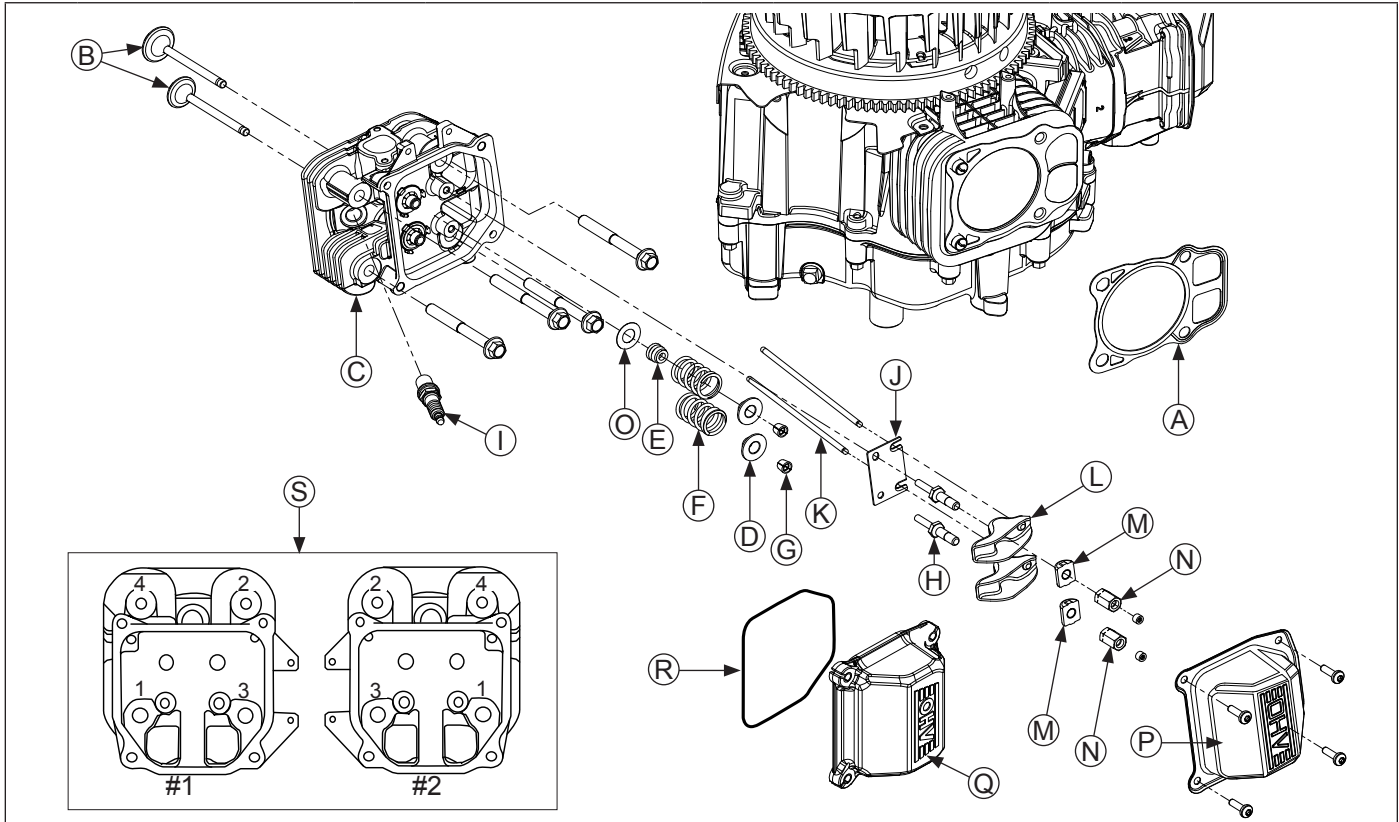

A	Gasket	B	Valve	C	Cylinder Head	D	Valve Spring Cap
E	Valve Stem Seal	F	Valve Spring	G	Valve Spring Keeper	H	Stud
I	Spark Plug	J	Guide Plate	K	Push Rod	L	Rocker Arm
M	Rocker Arm Pivots	N	Adjusters	O	Washer	P	Stamped Steel Valve Cover (RTV)
Q	Plastic Valve Cover (O-Ring)	R	O-Ring	S	Torque Sequence		

Assemble and Install Cylinder Heads

Valve Stem Seals

Use a new seal whenever valve is removed, or if seal is deteriorated or damaged. Never reuse an old seal.

Assemble Cylinder Heads

Prior to installation, lubricate all components with engine oil, paying particular attention to lip of valve stem seal, valve stems, and valve guides. Install following items in order listed below using a valve spring compressor.

- Intake and exhaust valves.
- Valve stem seal (intake valve only).
- Washer (intake valve only).
- Valve springs.
- Valve spring caps.
- Valve spring keepers.

Install Cylinder Heads

NOTE: Match numbers embossed on cylinder heads and crankcase.

NOTE: Push rods should always be installed in same position as before disassembly.

1. Check to make sure there are no nicks or burrs on sealing surfaces of cylinder head or crankcase. Make sure dowel locating pins are in lower 2 cylinder bolt holes on each side.
2. Install a new cylinder head gasket (with printing up) on each side.
3. Install each cylinder head and start 4 screws.
4. Torque screws in 2 stages; first to 22.6 N·m (200 in. lb.), then finally to 41.8 N·m (370 in. lb.), following sequence.

Install Rocker Arms

1. Note mark or tag identifying push rod as either intake or exhaust and cylinder 1 or 2. Check each push rod is straight and not bent. Dip ends of push rods in engine oil and install in their original positions, making sure each push rod ball seats in its tappet socket.
2. Install guide plate and studs. Torque studs to 11.3 N·m (100 in. lb.).

- Apply grease to contact surfaces of adjusters, rocker arms and rocker arm pivots. Install rocker arms and rocker arm pivots onto appropriate cylinder head, and install adjuster finger tight. Make sure set screw is backed out until flush with adjuster.

Adjust Valve Clearance

Adjusters Retaining Push Rods

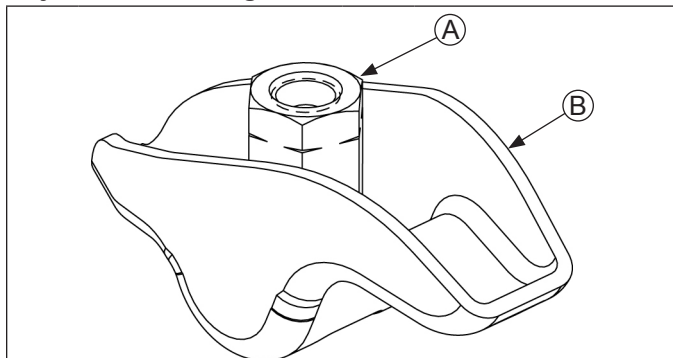

A	Adjuster	B	Rocker Arm
----------	----------	----------	------------

- Rotate crankshaft to establish TDC on compression stroke for cylinder 1.
Check for:
 - Compression will be felt through spark plug hole.
 - Keyway of crankshaft will be aligned with cylinder 1.
 - No rocker arm/push rod movement if crankshaft is rotated slightly back and forth. If they are moving, rotate crankshaft 1 full revolution.
- Insert a 0.127 mm (0.005 in.) feeler gauge between end of 1 valve and rocker arm. Turn adjuster until a slight drag is felt. Hold in this position and tighten setscrew securely. Torque setscrew to 7.9 N·m (70 in. lb.). After tightening recheck adjustment. Proper valve clearance is 0.101/0.152 mm (0.004/0.006 in.).
- Repeat procedure for other valve on side 1.
- Viewed from PTO end, rotate crankshaft 270° (3/4 turn) counterclockwise and align crankshaft keyway with cylinder 2, which now puts cylinder at TDC on compression stroke.
- Repeat steps 3-4 for setting valve clearance on side 2.
- Rotate crankshaft to check for free operation of valve train. Check for clearance between valve spring coils at full lift, or bending of push rod(s) can occur. Minimum allowable clearance is 0.25 mm (0.010 in.).

Check Assembly

Rotate crankshaft a minimum of 2 revolutions to check longblock assembly and overall proper operation.

Install Valve Covers

Plastic valve covers contain integral bolt hole spacers molded in place. Sealing of plastic valve covers is accomplished using a yellow colored O-ring. In stamped steel valve covers sealing is accomplished using RTV sealant.

Plastic Valve Covers

Plastic Valve Cover Torque Sequence

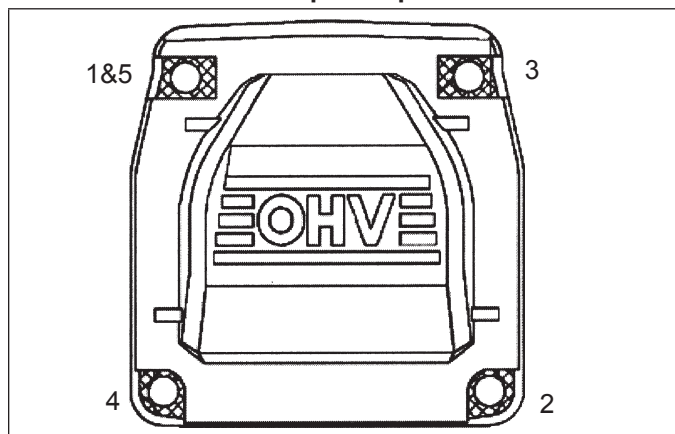

- Make sure sealing surfaces of valve covers and cylinder heads are clean and free of any nicks or burrs.
- Install a new O-ring in groove of each cover. Do Not use gaskets or RTV sealant.
- Position covers on cylinder heads. If a pulse style fuel pump is used, valve cover with pulse fitting hole must be installed on side 2. Install screws in each cover and finger tighten.
- Using sequence shown, torque valve cover screws to the appropriate torque for style of screw.

	Hex Flange to 9.0 N·m (80 in. lb.)
	Pan Head to 6.2 N·m (55 in. lb.)

Reassembly

Stamped Steel Valve Covers

Stamped Steel Valve Cover RTV Sealant

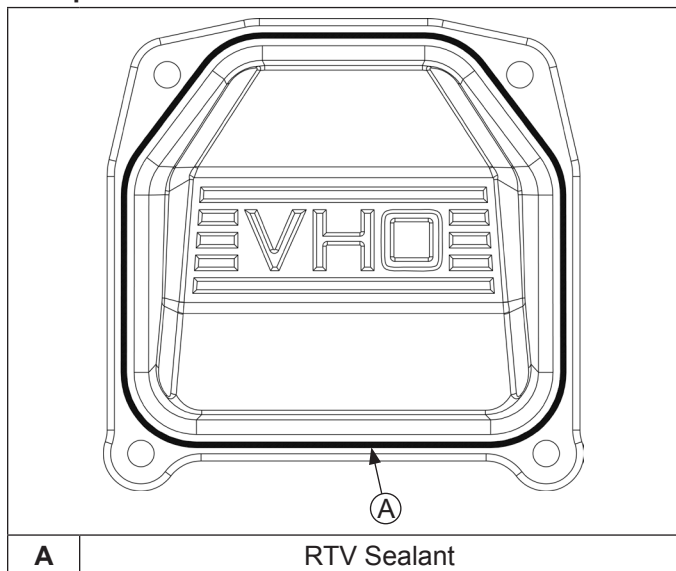

RTV silicone sealant is used as a gasket between valve cover and cylinder head. Refer to Tools and Aids for a listing of approved sealants.

1. Prepare sealing surfaces of cylinder heads and valve covers. Flatness of sealing surface must be checked prior to reinstallation. See Disassembly.
2. Apply a 1.5 mm (1/16 in.) bead of sealant to valve cover as shown.
3. Position covers on cylinder heads. Valve cover with pulse fitting hole must be installed on side 2. Install screws in each cover and finger tighten.
4. Torque valve cover fasteners to 13.6 N·m (120 in. lb.), using sequence shown.

Install Spark Plugs

1. Check gap using wire feeler gauge. Adjust gap to 0.76 mm (0.030 in.).
2. Install plug into cylinder head.
3. Torque plug to 27 N·m (20 ft. lb.).

Stamped Steel Valve Cover Torque Sequence

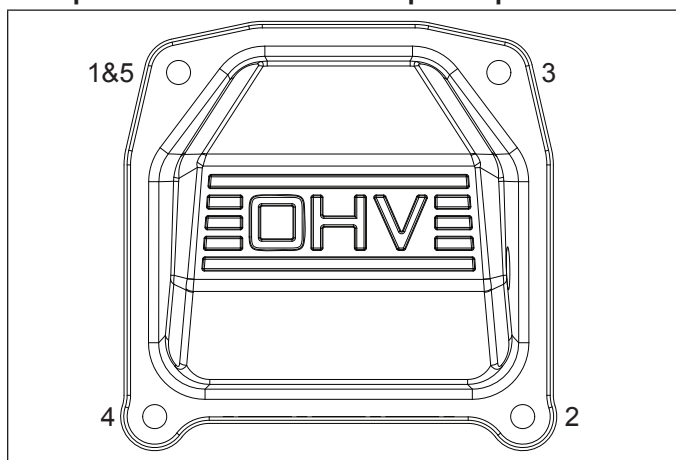

NOTE: Always use fresh sealant. Using outdated sealant can result in leakage. Refer to Tools and Aids for information on sealant dispenser.

NOTE: To ensure proper adhesion of sealant to both sealing surfaces, perform step 3 immediately (5 minutes maximum) after application of RTV.

Intake Manifold Components

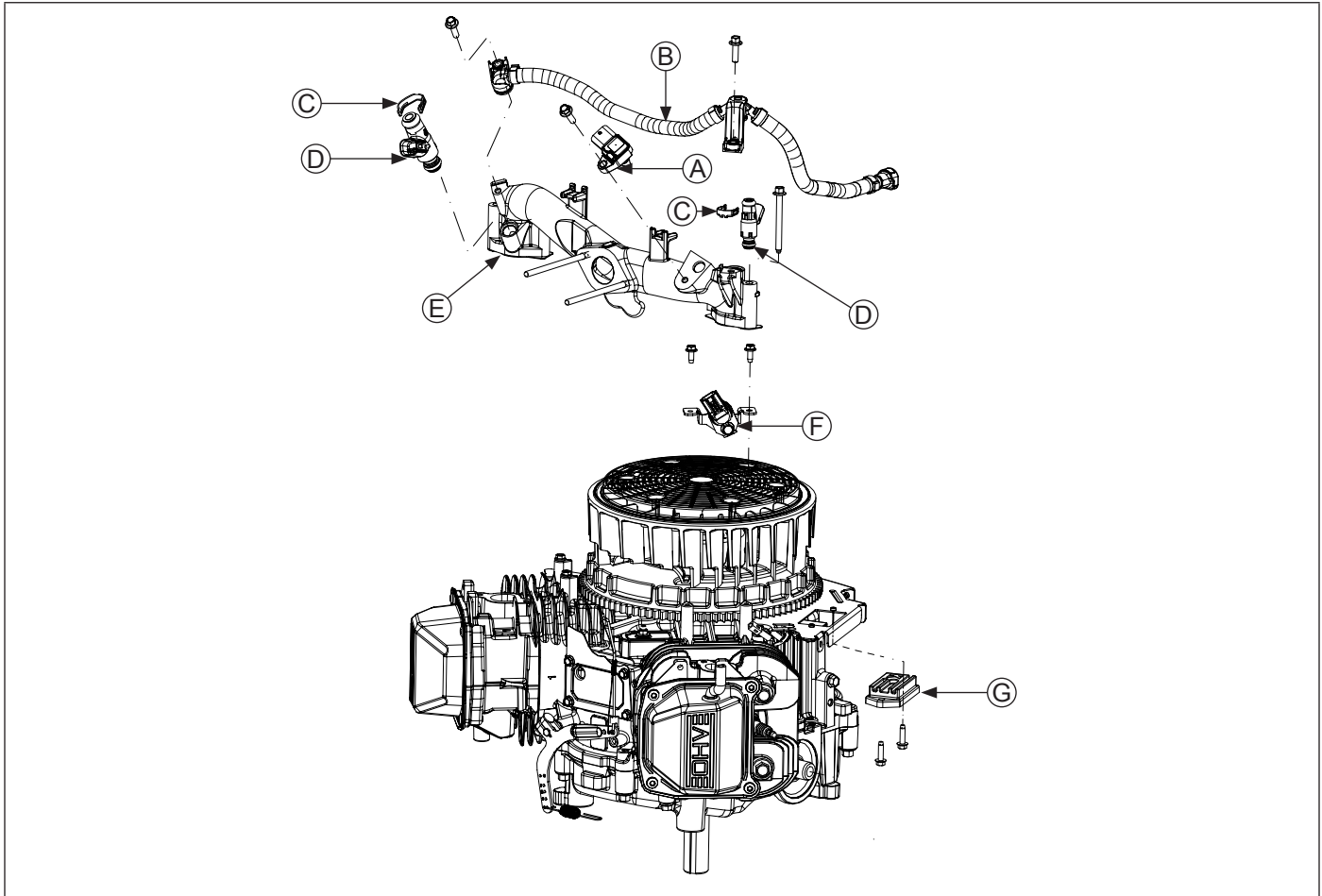

A	TMAP Sensor	B	Fuel Rail	C	Metal Retaining Clip	D	Fuel Injector
E	Intake Manifold	F	Crankshaft Position Sensor	G	Rectifier-Regulator		

Install Intake Manifold

Torque Sequence

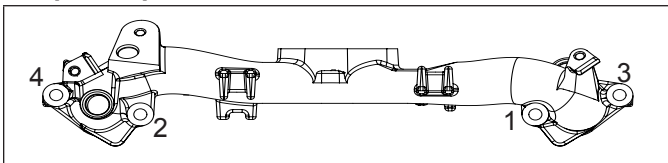

Install intake manifold using new gaskets, with wiring harness attached, onto cylinder heads. Reinstall any wiring harness clips and/or wire ties, if removed, before installing manifold. Install ground wire to boss and torque to 7.3 N·m (65 in. lb.). Using sequence shown, torque screws to 10.5 N·m (93 in. lb.).

Install Rectifier-Regulator

1. Connect rectifier-regulator B+ (purple) wire to wiring harness.
2. Attach rectifier-regulator to opening in backing plate from underside, and secure with screws. Torque screws to 3.4 N·m (30 in. lb.).
3. Route wire into support clip in backing plate.

Install Fuel Injectors

NOTE: Ensure all parts are clean, undamaged and free of debris and make sure electrical connectors have seal in place.

O-rings and retaining clips should be replaced any time fuel injector is separated from its normal mounting position.

Reassembly

1. Lightly lubricate fuel injector O-rings with clean engine oil.
2. Push retaining clip onto fuel injector, aligning clip as shown.
3. Press fuel injector into fuel injector cap until retaining clip snaps into place.
4. Press fuel injector into bore in intake manifold and rotate to original position.
5. Install fuel injector cap screw into intake manifold and torque to 7.3 N·m (65 in. lb.).
6. Push electrical connector on fuel injector making sure a good connection is made.
7. Repeat steps 1 through 6 for other fuel injector.

Install Temperature/Manifold Absolute Pressure (TMAP) Sensor

NOTE: Ensure all parts are clean, undamaged and free of debris and make sure electrical connector has seal in place.

1. Lightly oil TMAP sensor O-ring and push sensor into bore in intake manifold.
2. Torque screw to 7.3 N·m (65 in. lb.).
3. Push electrical connector on TMAP sensor making sure a good connection is made. Slide down lock tab.

Install Crankshaft Position Sensor

NOTE: Ensure all parts are clean, undamaged and free of debris and make sure electrical connectors have seal in place.

1. Install crankshaft position sensor and bracket assembly to crankcase posts.
2. Secure bracket assembly to crankcase posts. Torque bracket screws to 8.3 N·m (73 in. lb.).
3. Push electrical connector on crankshaft position sensor making sure a good connection is made.

Starter and Electronic Control Unit (ECU) Components

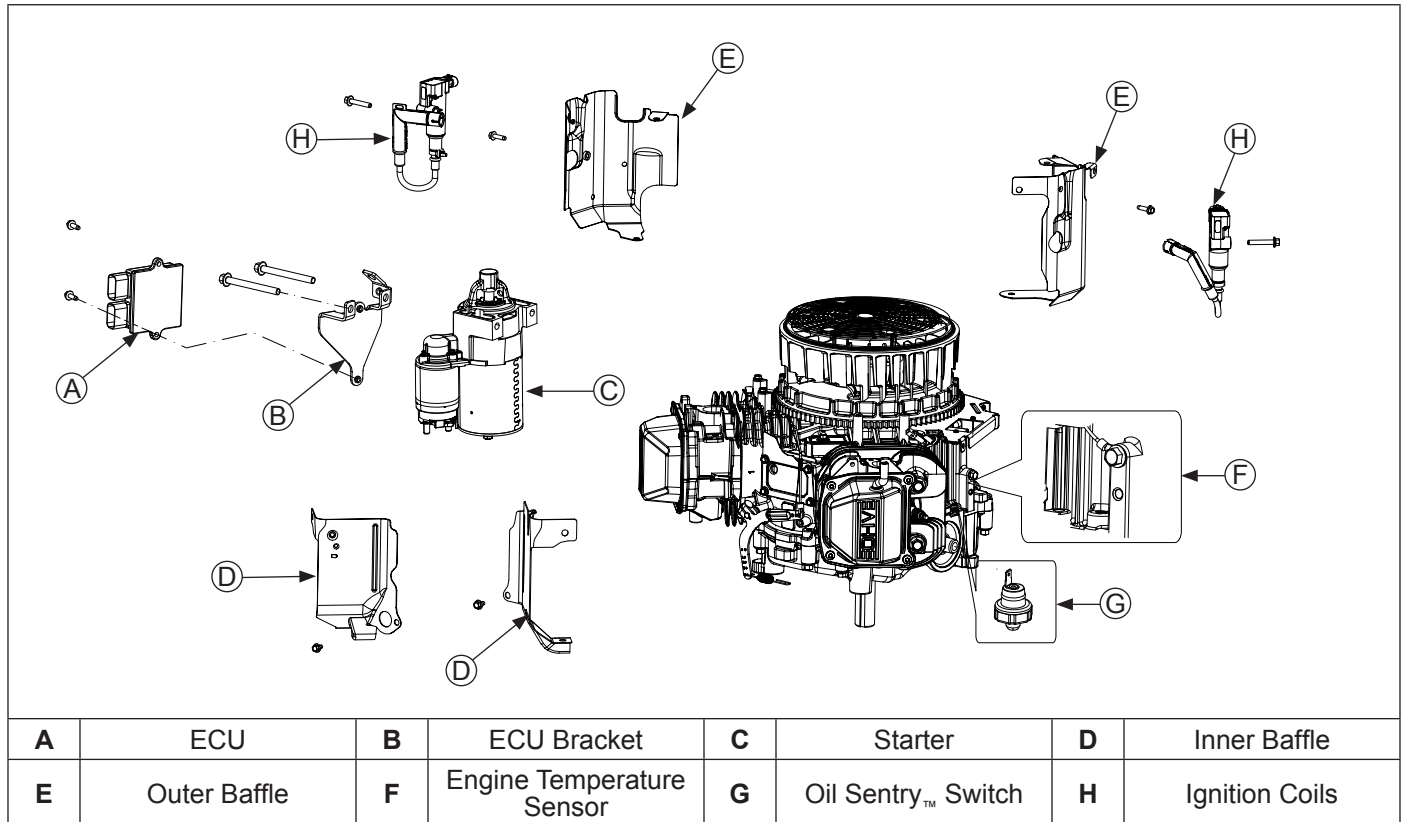

Install Inner and Outer Baffles

1. Attach inner baffles aligning top to cylinder head flanges and to crankcase mounting bosses.
2. Install both outer baffles. Ensure top tab is under blower housing base and bottom tab aligned to cylinder block. Ensure stator wires and rectifier-regulator wires are not pinched when installing #2 outer baffle.
3. Secure with screws and torque M5 screws to 8.5 N·m (75 in. lb.) into a new cored hole, or 4.0 N·m (35 in. lb.) into a used hole. Torque M6 screws to 10.7 N·m (95 in. lb.) into a new cored hole, or 7.3 N·m (65 in. lb.) into a used hole.
4. If removed, install ignition coils onto baffles.
5. Plug connectors into ignition coils.
6. Secure engine temperature sensor to crankcase with screw. Torque screw to 11.9 N·m (105 in. lb.).
7. Connect wire lead (green) to Oil Sentry™ terminal.
8. Install vent hose assembly clip in #1 inner baffle.

Install Electric Starter Motor and ECU Bracket

1. Insert starter bolts into ECU bracket and starter. Mount starter.
2. Torque screws to 23.8 N·m (211 in. lb.).
3. Connect leads to solenoid.

Install ECU

NOTE: ECU pins should be coated with a thin layer of electrical grease to prevent fretting and corrosion and may need to be reapplied if ECU is being reused.

1. Install ECU to ECU bracket using screws. Torque M5 screws to 6.2 N·m (55 in. lb.) into new holes or 4.0 N·m (35 in. lb.) into used holes.
2. Connect Black and Grey electrical connectors. Connectors and ECU are keyed in such a way so they cannot be installed incorrectly.

Reassembly

Air Cleaner/Throttle Body Components

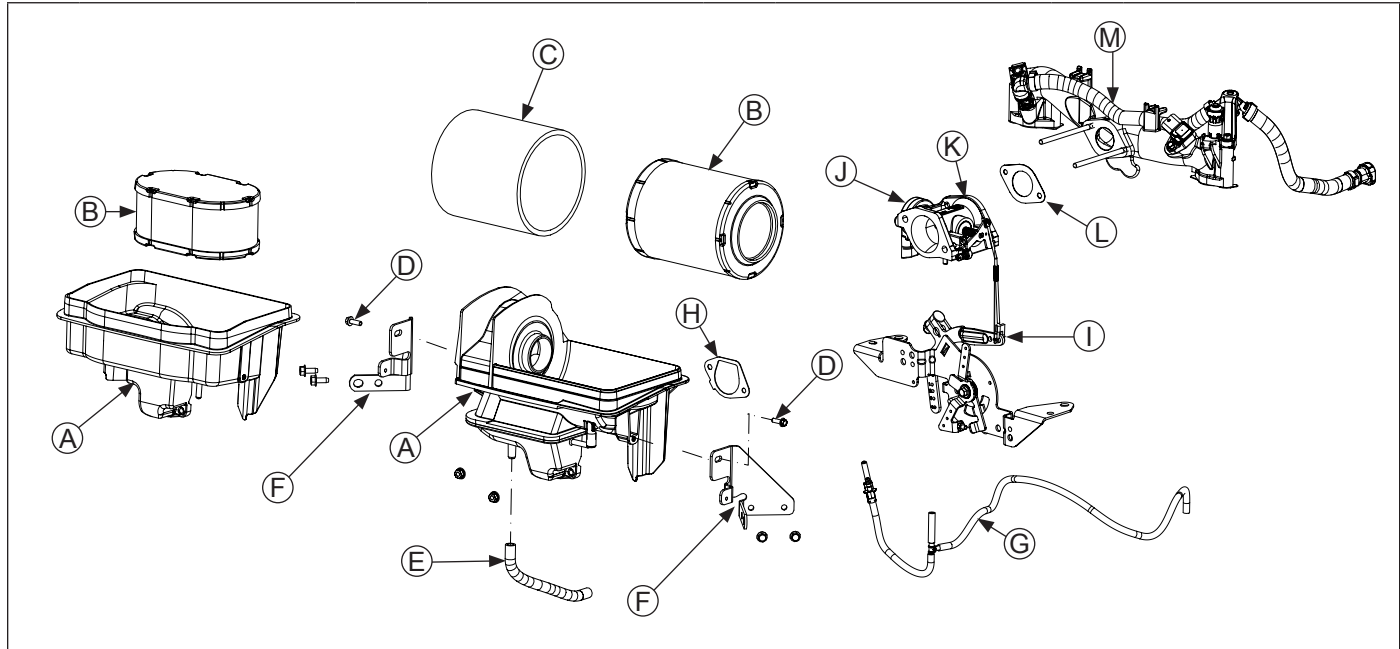

A	Air Cleaner Base	B	Air Cleaner Element	C	Precleaner	D	Side Screw
E	Breather Hose	F	Combination Air Cleaner Base Bracket/Lifting Strap	G	Vent Hose Assembly	H	Air Cleaner Gasket
I	Throttle Body/Throttle Linkage/Governor Lever Assembly	J	Throttle Position Sensor (TPS)	K	Throttle Body	L	Throttle Body Gasket
M	Intake Manifold						

Install Throttle Body and Air Cleaner Base

NOTE: Ensure all parts are clean, undamaged and free of debris and make sure electrical connector has seal in place.

1. Install a new throttle body gasket prior to installation.
2. Install throttle body, throttle linkage, and governor lever, as an assembly.
3. Install vent hose assembly to throttle body.
4. Push electrical connector onto throttle position sensor (TPS) making sure a good connection is made.
5. Install air cleaner base with new air cleaner base gasket onto mounting studs. Torque nuts to 6.8 N·m (60 in. lb.).
6. Connect breather hose to air cleaner base.

Install Air Cleaner Base Brackets/Lifting Straps

1. Install combination air cleaner base brackets/lifting straps to each cylinder head with M6 screws. Do not tighten at this time.
Both brackets mount on top of inner and outer baffle tabs.
2. Secure air cleaner base with side screws and torque to 7.3 N·m (65 in. lb.).
3. Torque M6 screws to 10.7 N·m (95 in. lb.) into a new cored hole, or 7.3 N·m (65 in. lb.) into a used hole.

Install Throttle Controls

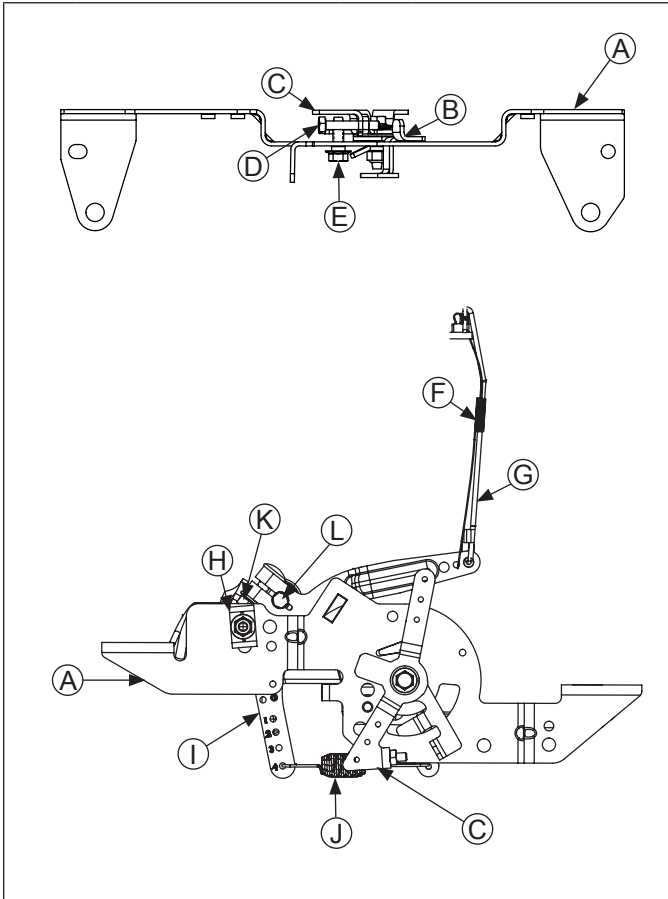

A	Control Bracket	B	Throttle Actuator Lever
C	Throttle Lever	D	Hex Head Screw
E	Hex Lock Nut	F	Linkage Spring
G	Governor Linkage	H	Cable Clamp
I	Governor Lever	J	Governor Spring
K	Nut	L	Cross Shaft

1. Install governor lever onto governor cross shaft if disconnected previously.
2. Make sure throttle linkage, linkage spring, and black linkage bushing are connected to governor lever and to throttle lever on throttle body.
3. Move governor lever and spring toward throttle body as far as it will go (wide-open throttle), and hold in position.
4. Use 7 mm hex socket on end of cross shaft and rotate shaft counterclockwise (viewed from end) as far as it will turn, then torque nut to 6.8 N·m (60 in. lb.).

Governor Lever Hole Position

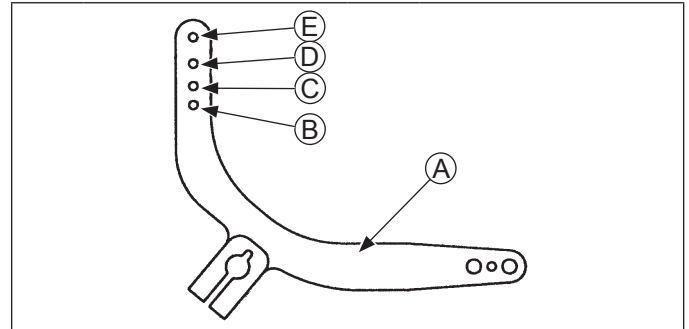

A	Governor Lever	B	Hole 1
C	Hole 2	D	Hole 3
E	Hole 4		

1. Install main control bracket to cylinder heads using screws. Two lower screws should also secure inner baffles. Torque screws to 10.7 N·m (95 in. lb.) into new holes, or 7.3 N·m (65 in. lb.) into used holes.
2. Connect governor spring from throttle control bracket to appropriate hole in governor lever.

Install Air Cleaner Element

Install air cleaner element (with precleaner if equipped), onto air cleaner base.

Reassembly

Install Fuel Pump Module (FPM)

	▲ WARNING
	<p>Explosive Fuel can cause fires and severe burns.</p> <p>Do not fill fuel tank while engine is hot or running.</p>
<p>Gasoline is extremely flammable and its vapors can explode if ignited. Store gasoline only in approved containers, in well ventilated, unoccupied buildings, away from sparks or flames. Spilled fuel could ignite if it comes in contact with hot parts or sparks from ignition. Never use gasoline as a cleaning agent.</p>	

FPM Components

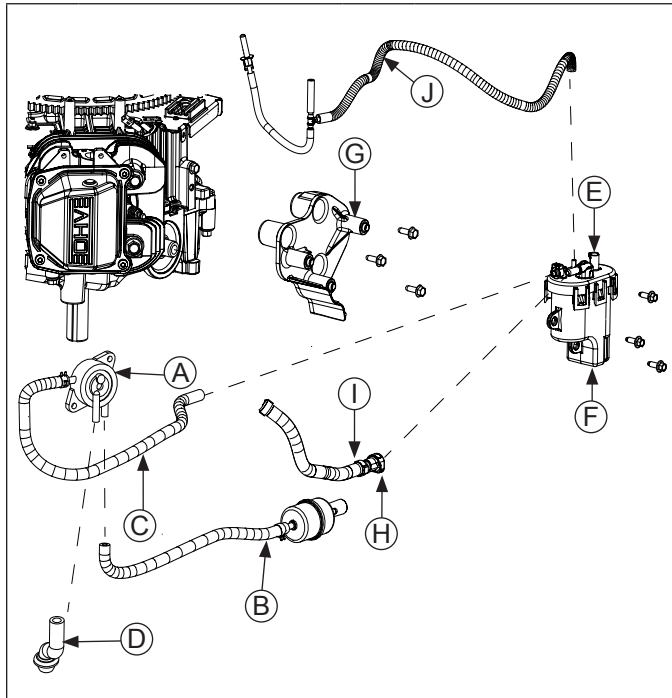

A	Pulse Pump	B	Inlet Line
C	Outlet to FPM	D	Pulse Line
E	Electrical Connector	F	FPM
G	FPM Baffle	H	High Pressure Fuel Line Connector
I	Oetiker Clamp	J	Vent Hose Assembly

NOTE: Ensure all parts are clean, undamaged and free of debris and make sure electrical connector has seal in place.

NOTE: FPM pins should be coated with a thin layer of electrical grease to prevent fretting and corrosion and may be reapplied if FPM is being reused.

1. Install screws to secure fuel pump module baffle to crankcase. Torque screws to 11.9 N·m (105 in. lb.) into new holes, or 7.8 N·m (69 in. lb.) into used holes.
2. Push high pressure fuel line connector onto FPM fitting.
3. If Oetiker clamp was cut to remove inlet fuel line, slide a new Oetiker clamp onto fuel line and connect fuel line. Only use an Oetiker clamp pliers to crimp Oetiker clamps. Oetiker clamp crimp must point up, away from top of FPM and abrasion sleeve must be positioned over Oetiker clamp.
4. Connect electrical connector to top of FPM. Ensure grey locking tab is pulled out before connecting. Push connector onto terminal until a click is heard, then push in grey locking tab to lock connector.
5. Install FPM to baffle using screws. Torque screws to 9.2 N·m (81 in. lb.).

External Engine Components

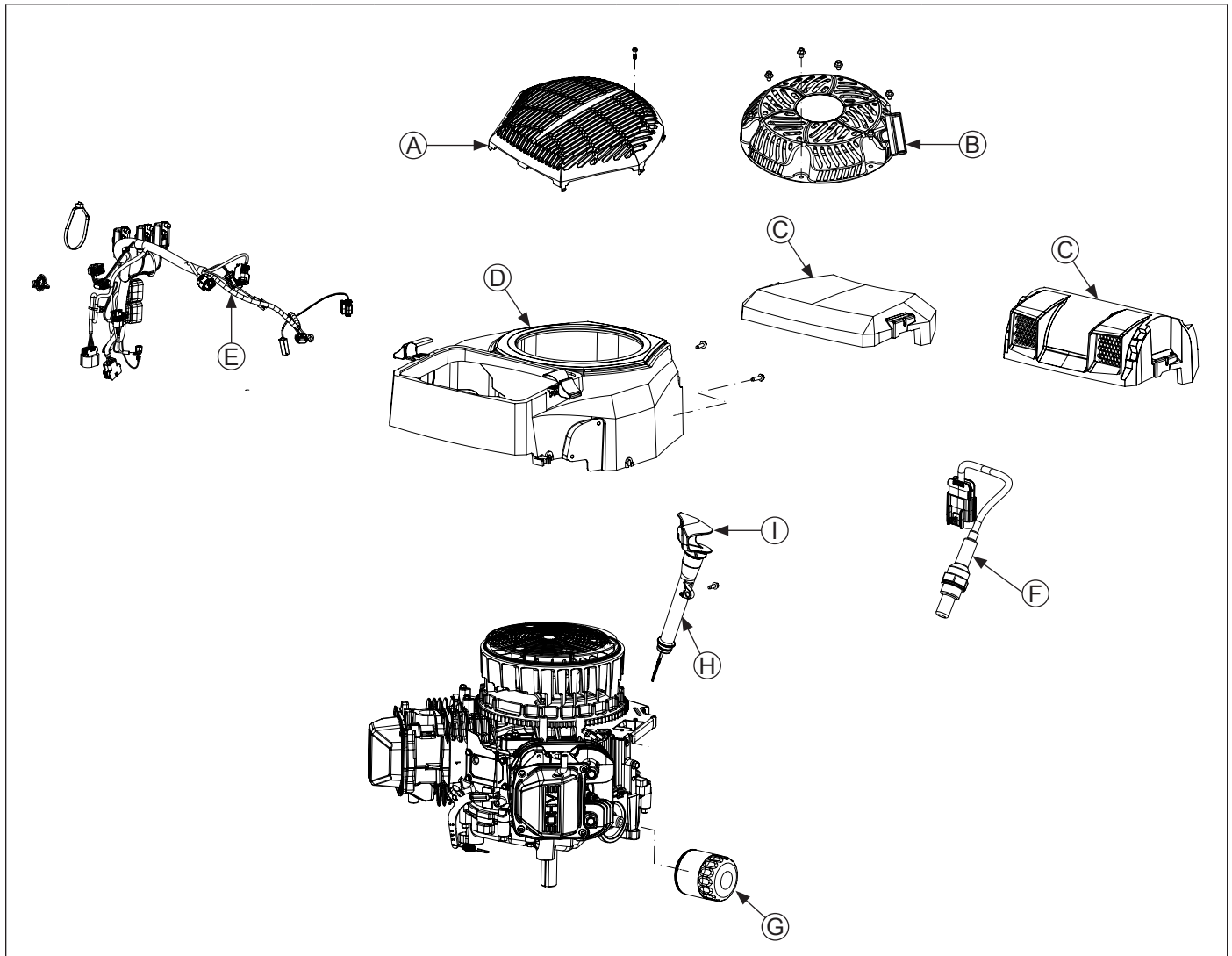

A	Fixed Guard	B	Retractable Starter	C	Air Cleaner Cover	D	Blower Housing
E	Wire Harness	F	Oxygen Sensor	G	Oil Filter	H	Dipstick Tube
I	Oil Fill/Dipstick						

Install Blower Housing

NOTE: Do not completely tighten screws until all are installed to allow shifting for hole alignment.

1. Install blower housing onto engine. Attach cable clip on #1 side of blower housing and start all screws. Make sure wire harness and fuel lines exit out through appropriate openings in shrouding. Attach any fuel line clamps used.
2. Torque screws as follows:
 M5 Thread Forming Fasteners: 3.4 N·m (30 in. lb.).
 M4 HI-LO Screws: 2.8 N·m (25 in. lb.).
 M3 HI-LO Screws: 2.3 N·m (20 in. lb.).
3. Install air cleaner cover. Ensure spring clips are securely fastened.
4. Snap fuse holders into fuse covers on side of blower housing.

Reassembly

Install Fixed Guard (if equipped)

Install fixed guard. Torque screw to 0.85 N·m (7.5 in. lb.).

Install Fixed Guard and Chopper Screen (if equipped)

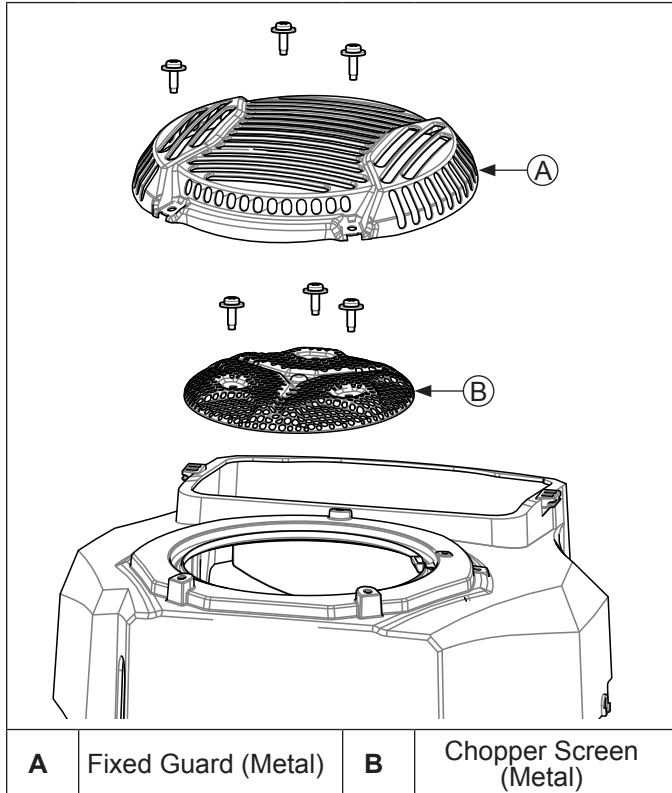

1. Place screen on housing. Install screws securing chopper screen to screen cup. Torque screws to 4.0 N·m (35 in. lb.).
2. Place guard on housing. Install screws securing metal guard to blower housing. Torque screws to 2.6 N·m (23 in. lb.).

Install Retractable Starter (if equipped)

1. Install retractable starter on blower housing using screws. Finger tighten screws only.
2. Pull rope handle to engage pawls and center starter to drive cup. Hold in this position and torque screws to 7.3 N·m (65 in. lb.).

Install Dipstick Tube

1. Lubricate dipstick tube O-ring and install into crankcase.
2. Secure to backing plate using M5 screw and torque to 3.4 N·m (30 in. lb.).

Install Fuel Pulse Pump

	▲ WARNING
	<p>Explosive Fuel can cause fires and severe burns.</p> <p>Do not fill fuel tank while engine is hot or running.</p>
<p>Gasoline is extremely flammable and its vapors can explode if ignited. Store gasoline only in approved containers, in well ventilated, unoccupied buildings, away from sparks or flames. Spilled fuel could ignite if it comes in contact with hot parts or sparks from ignition. Never use gasoline as a cleaning agent.</p>	

Fuel Pulse Pump Components

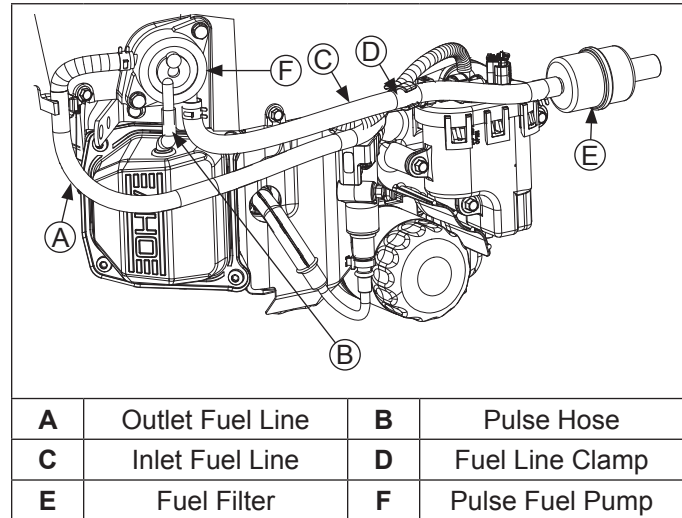

NOTE: If a new fuel pump is being installed, make sure orientation of new pump is consistent with removed pump. Internal damage may occur if installed incorrectly.

1. Install pulse fuel pump and lines as an assembly.
2. Install pulse fuel pump to housing using screws. Torque screws to 2.8 N·m (25 in. lb.).
3. Connect inlet and outlet fuel lines to pump. Route inlet fuel line through fuel line clamp (if used) as shown.
4. If removed, connect in-line 10 micron EFI fuel filter and hose to inlet barb of lift fuel pump and secure with spring clamp.

Install Muffler (if equipped)

1. Install exhaust gaskets and muffler. Install nuts to exhaust studs. Torque hex nuts to 24.4 N·m (216 in. lb.), lock nuts to 27.8 N·m (246 in. lb.). Install oxygen sensor, torque to 18 N·m (159 in. lb.), and connect to wire harness.
2. Install remaining muffler support hardware and torque to 9.9 N·m (88 in. lb.).

Connect Spark Plug Leads

Connect leads to spark plugs.

Install Oil Filter and Fill Crankcase with Oil

NOTE: Make sure oil drain plug is installed and torqued to specification to prevent oil leakage.

1. Install oil drain plug. Torque plug to 13.6 N·m (10 ft. lb.).
2. Place new filter in shallow pan with open end up. Fill with new oil until oil reaches bottom of threads. Allow 2 minutes for oil to be absorbed by filter material.
3. Apply a thin film of clean oil to rubber gasket on new filter.
4. Refer to instructions on oil filter for proper installation.
5. Fill crankcase with new oil. Level should be at top of indicator on dipstick.
6. Reinstall oil fill/dipstick and tighten securely.

Prepare Engine for Operation

NOTE: If ECU, throttle body, TPS or fuel pump module were replaced, an ECU Reset and TPS Learn is required. Refer to Electrical System Reset and TPS Learn procedure.

Engine is now completely reassembled. Before starting or operating engine, be sure to follow steps below.

1. Make sure all hardware is tightened securely.
2. Make sure oil drain plugs, Oil Sentry™ pressure switch, and a new oil filter are installed.
3. Verify crankcase has been filled with correct amount, weight, and type of oil. Refer to oil recommendations and procedures in Maintenance, Specifications, and Lubrication System.
4. Turn on fuel supply.

Testing Engine

It is recommended engine be operated on a stand or bench prior to installation in piece of equipment.

1. Run engine at idle for 2-3 minutes, then 5-6 minutes more between idle and midrange.
2. Adjust idle speed screw and high speed as necessary. Make sure maximum engine speed does not exceed 3750 RPM (no load).



1P16 690 07



8 85612 45942 8