

Command

CV173, CV200, CV224

Service Manual

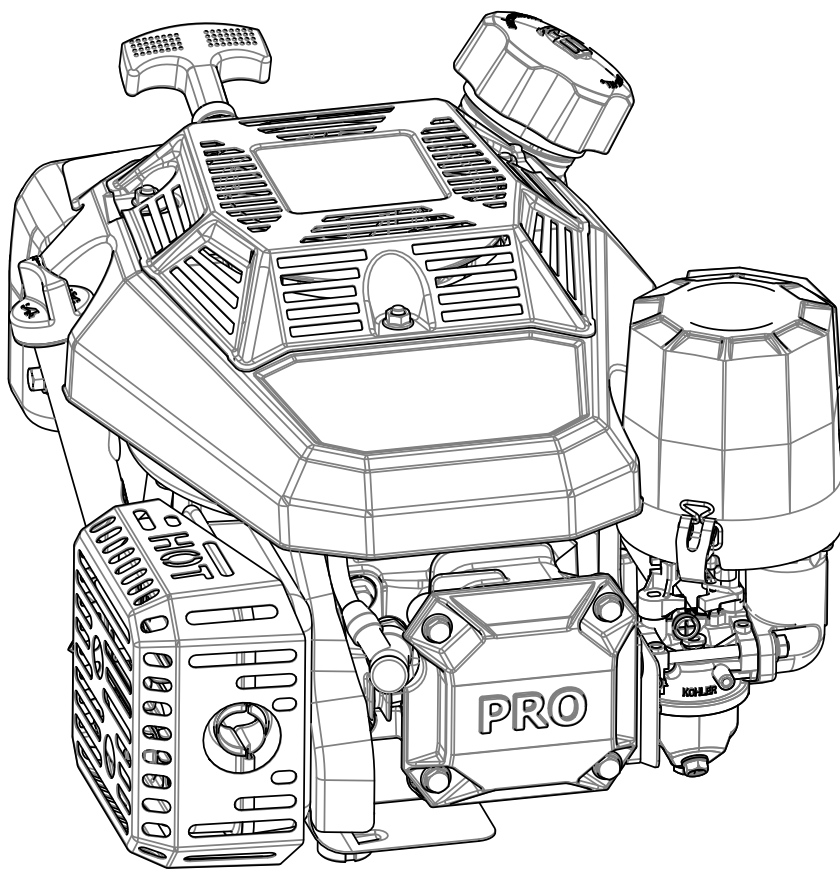

Kohler Engines
is now Rehlko.

2	Safety
3	Maintenance
5	Specifications
19	Tools and Aids
22	Troubleshooting
27	Air Cleaner/Intake
28	Fuel System
32	Governor System
34	Lubrication System
35	Electrical System
38	Starter System
39	Disassembly/Inspection and Service
51	Reassembly

IMPORTANT: Read all safety precautions and instructions carefully before operating equipment. Refer to operating instruction of equipment that this engine powers.

Ensure engine is stopped and level before performing any maintenance or service.

Safety

SAFETY PRECAUTIONS

⚠ WARNING: A hazard that could result in death, serious injury, or substantial property damage.

⚠ CAUTION: A hazard that could result in minor personal injury or property damage.

NOTE: is used to notify people of important installation, operation, or maintenance information.

	⚠ WARNING
	Explosive Fuel can cause fires and severe burns. Do not fill fuel tank while engine is hot or running.
Gasoline is extremely flammable and its vapors can explode if ignited. Store gasoline only in approved containers, in well ventilated, unoccupied buildings, away from sparks or flames. Spilled fuel could ignite if it comes in contact with hot parts or sparks from ignition. Never use gasoline as a cleaning agent.	

	⚠ WARNING
	Rotating Parts can cause severe injury. Stay away while engine is in operation.
Keep hands, feet, hair, and clothing away from all moving parts to prevent injury. Never operate engine with covers, shrouds, or guards removed.	

	⚠ WARNING
	Carbon Monoxide can cause severe nausea, fainting or death. Avoid inhaling exhaust fumes. Never run engine indoors or in enclosed spaces.
Engine exhaust gases contain poisonous carbon monoxide. Carbon monoxide is odorless, colorless, and can cause death if inhaled.	

	⚠ WARNING
	Accidental Starts can cause severe injury or death. Disconnect and ground spark plug lead(s) before servicing.
Before working on engine or equipment, disable engine as follows: 1) Disconnect spark plug lead(s). 2) Disconnect negative (-) battery cable from battery.	

	⚠ WARNING
	Hot Parts can cause severe burns. Do not touch engine while operating or just after stopping.
Never operate engine with heat shields or guards removed.	



	⚠ WARNING
	Cleaning Solvents can cause severe injury or death. Use only in well ventilated areas away from ignition sources.
Carburetor cleaners and solvents are extremely flammable. Follow cleaner manufacturer's warnings and instructions on its proper and safe use. Never use gasoline as a cleaning agent.	

	⚠ CAUTION
	Electrical Shock can cause injury. Do not touch wires while engine is running.

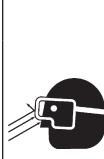
	⚠ CAUTION
	Damaging Crankshaft and Flywheel can cause personal injury.
Using improper procedures can lead to broken fragments. Broken fragments could be thrown from engine. Always observe and use precautions and procedures when installing flywheel.	

	⚠ WARNING
	Uncoiling Spring can cause severe injury. Wear safety goggles or face protection when servicing retractable starter.
Retractable starters contain a powerful, recoil spring that is under tension. Always wear safety goggles when servicing retractable starters and carefully follow instructions in Retractable Starter for relieving spring tension.	

MAINTENANCE INSTRUCTIONS

  	⚠ WARNING	Before working on engine or equipment, disable engine as follows: 1) Disconnect spark plug lead(s). 2) Disconnect negative (-) battery cable from battery.
	Accidental Starts can cause severe injury or death. Disconnect and ground spark plug lead(s) before servicing.	

Normal maintenance, replacement or repair of emission control devices and systems may be performed by any repair establishment or individual; however, warranty repairs must be performed by a Rehlko authorized dealer.

MAINTENANCE SCHEDULE

Before Every Use

● Check oil level. Add oil if low. Do not overfill.	Lubrication System
● Check air cleaner for dirty, loose or damaged parts.	Air Cleaner/Intake
● Check precleaner for dirty or torn material.	Air Cleaner/Intake

After first 8 Hours

● Change oil (NOT required if using Xtended Life PRO 10W-50 full-synthetic oil).	Lubrication System
--	--------------------

Every 50 Hours or Annually¹ (whichever comes first)

● Service/replace precleaner.	Air Cleaner/Intake
-------------------------------	--------------------

Every 100 Hours or Annually¹ (whichever comes first)

● Change oil and oil filter.	Lubrication System
● Clean cooling areas.	Air Cleaner/Intake
● Replace fuel filter (if equipped).	
● Clean spark arrestor (if equipped).	

Every 300 Hours¹

● Replace air cleaner element and precleaner.	Air Cleaner/Intake
---	--------------------

Every 300 Hours²

● Check and replace guide plate, if needed.	Disassembly/Reassembly
● Check and adjust valve clearance when engine is cold.	Reassembly

Every 300 Hours³

● Change oil and oil filter (Xtended Life PRO 10W-50 oil and Xtended Life PRO filter only).	Lubrication System
---	--------------------

Every 500 Hours or Annually¹ (whichever comes first)

● Replace spark plug and set gap.	Electrical System
-----------------------------------	-------------------

¹ Perform these procedures more frequently under severe, dusty, dirty conditions.

² Have a Rehlko authorized dealer perform this service.

³ Option only if using Xtended Life PRO oil and Xtended Life PRO filter.

REPAIRS/SERVICE PARTS

Rehlko genuine service parts can be purchased from Rehlko authorized dealers. To find a local Rehlko authorized dealer visit Engines.rehlko.com or call 1-800-544-2444 (U.S. and Canada).

Maintenance

OIL RECOMMENDATIONS

All-season Xtended Life PRO 10W-50 Synthetic Oil is the ideal oil for Rehlko engines. It is specifically formulated to extend the oil and oil filter change interval to 300 Hours when paired with a Xtended Life PRO Oil Filter.

300-Hour oil and oil filter change intervals are exclusive to and only authorized on Rehlko engines that utilize both the Xtended Life PRO 10W-50 Synthetic Oil and Xtended Life PRO Oil Filter. Alternative engine oils and oil filters may be used with Rehlko engines but require 100-Hour oil and oil filter change intervals for proper maintenance. Oil must be API (American Petroleum Institute) service class SJ or higher. Select viscosity based on air temperature at time of operation as shown below.

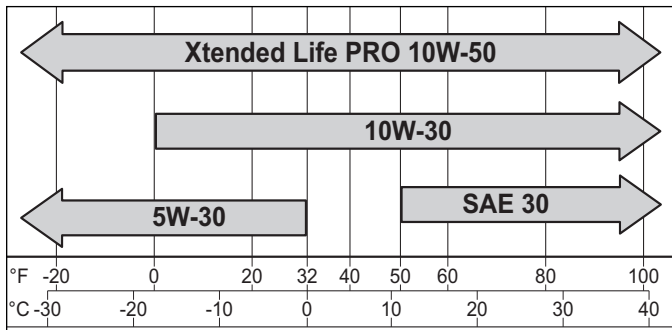

FUEL RECOMMENDATIONS

	⚠ WARNING
	<p>Explosive Fuel can cause fires and severe burns.</p> <p>Do not fill fuel tank while engine is hot or running.</p>
<p>Gasoline is extremely flammable and its vapors can explode if ignited. Store gasoline only in approved containers, in well ventilated, unoccupied buildings, away from sparks or flames. Spilled fuel could ignite if it comes in contact with hot parts or sparks from ignition. Never use gasoline as a cleaning agent.</p>	

NOTE: E15, E20 and E85 are NOT approved and should NOT be used; effects of old, stale or contaminated fuel are not warrantable.

Fuel must meet these requirements:

- Clean, fresh, unleaded gasoline.
- Octane rating of 87 (R+M)/2 or higher.
- Research Octane Number (RON) 90 octane minimum.
- Gasoline up to 10% ethyl alcohol, 90% unleaded is acceptable.
- Methyl Tertiary Butyl Ether (MTBE) and unleaded gasoline blend (max 15% MTBE by volume) are approved.
- Do not add oil to gasoline.
- Do not overfill fuel tank.
- Do not use gasoline older than 30 days.

STORAGE

If engine will be out of service for 2 months or more follow procedure below.

1. Add PRO Series fuel treatment or equivalent to fuel tank. Run engine 2-3 minutes to get stabilized fuel into fuel system (failures due to untreated fuel are not warrantable).
2. Change oil while engine is still warm from operation (NOT required if using Xtended Life PRO 10W-50 full-synthetic oil). Remove spark plug(s) and pour about 1 oz. of engine oil into cylinder(s). Replace spark plug(s) and crank engine slowly to distribute oil.
3. Store engine in a clean, dry place.

CV173 Engine Dimensions-Flywheel Side

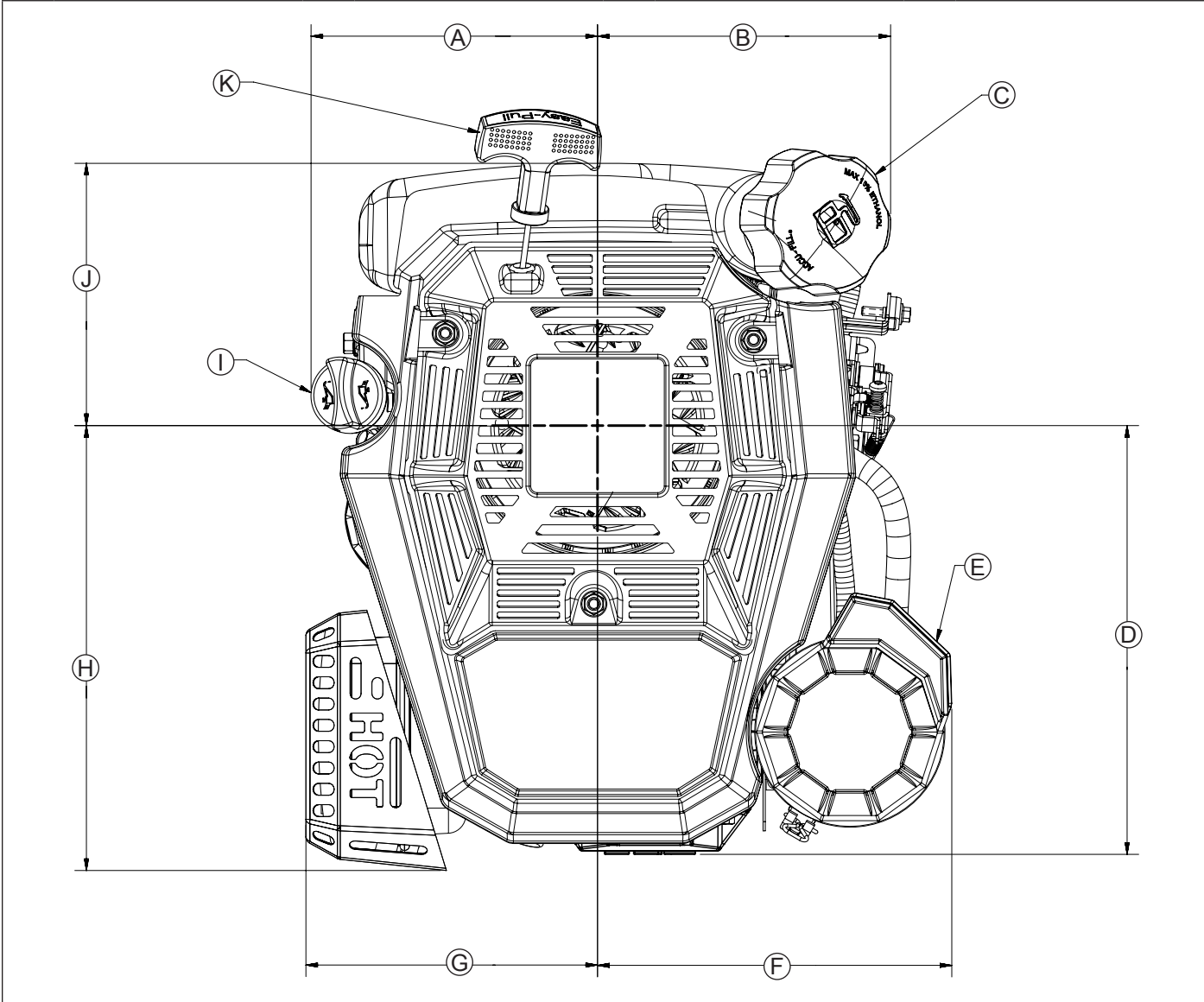

A	156.59 mm (6.165 in.)	B	160.21 mm (6.308 in.)	C	Fuel Fill	D	234.35 mm (9.226 in.)
E	Air Filter and Cover	F	193.66 mm (7.625 in.)	G	159.40 mm (6.276 in.)	H	243.17 mm (9.574 in.)
I	Oil Fill and Dipstick	J	143.35 mm (5.644 in.)	K	Recoil Rear Pull		

Specifications

CV173 Engine Dimensions-Valve Cover Side

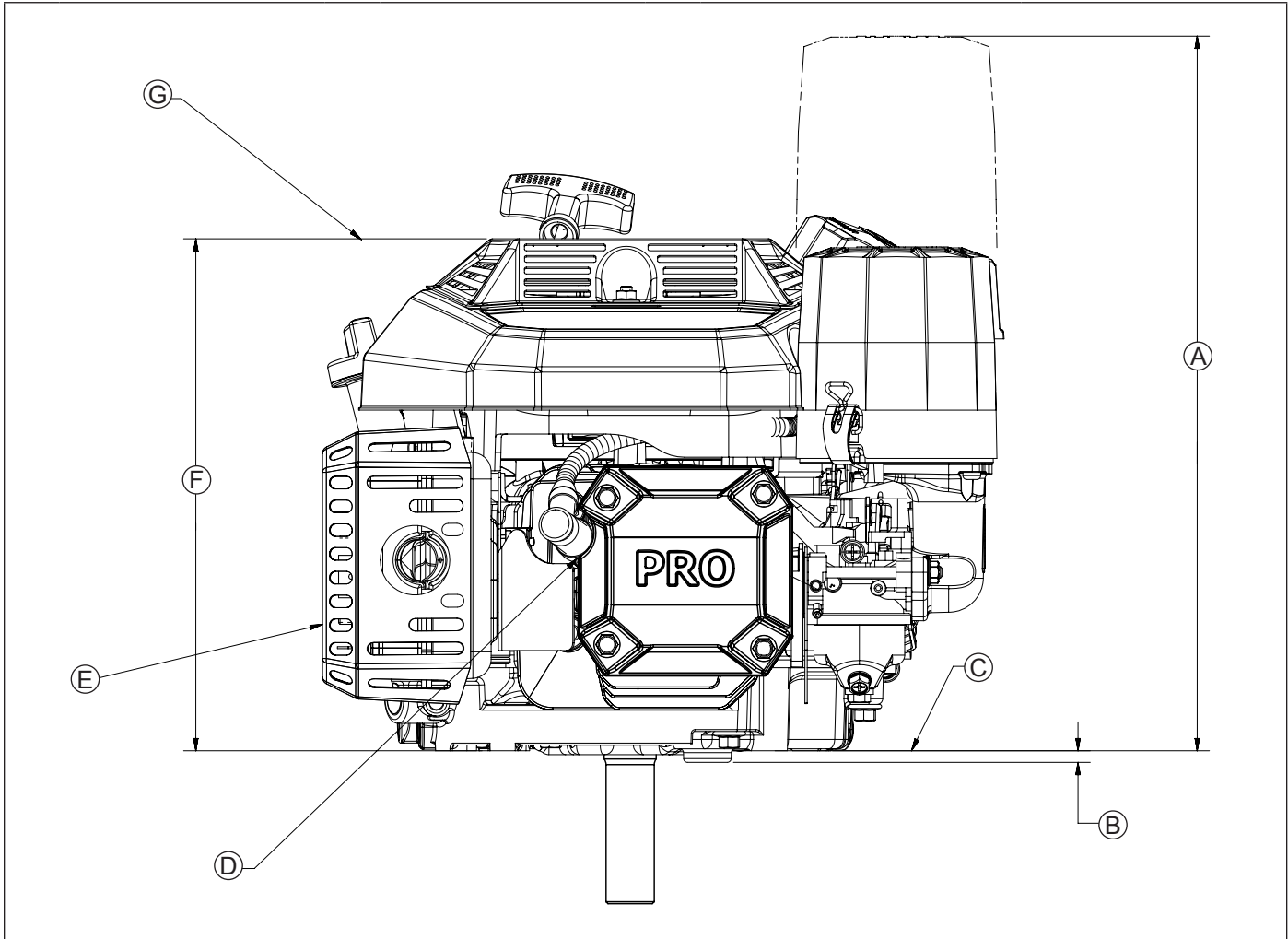

A	370.01 mm (14.567 in.) Air Cleaner Cover Removal	B	6.00 mm (0.236 in.)	C	Engine Mounting Surface	D	Spark Plug
E	Front Exit Muffler	F	265.11 mm (10.437 in.)	G	Top of Recoil		

CV173 Engine Dimensions-Fuel Tank Side

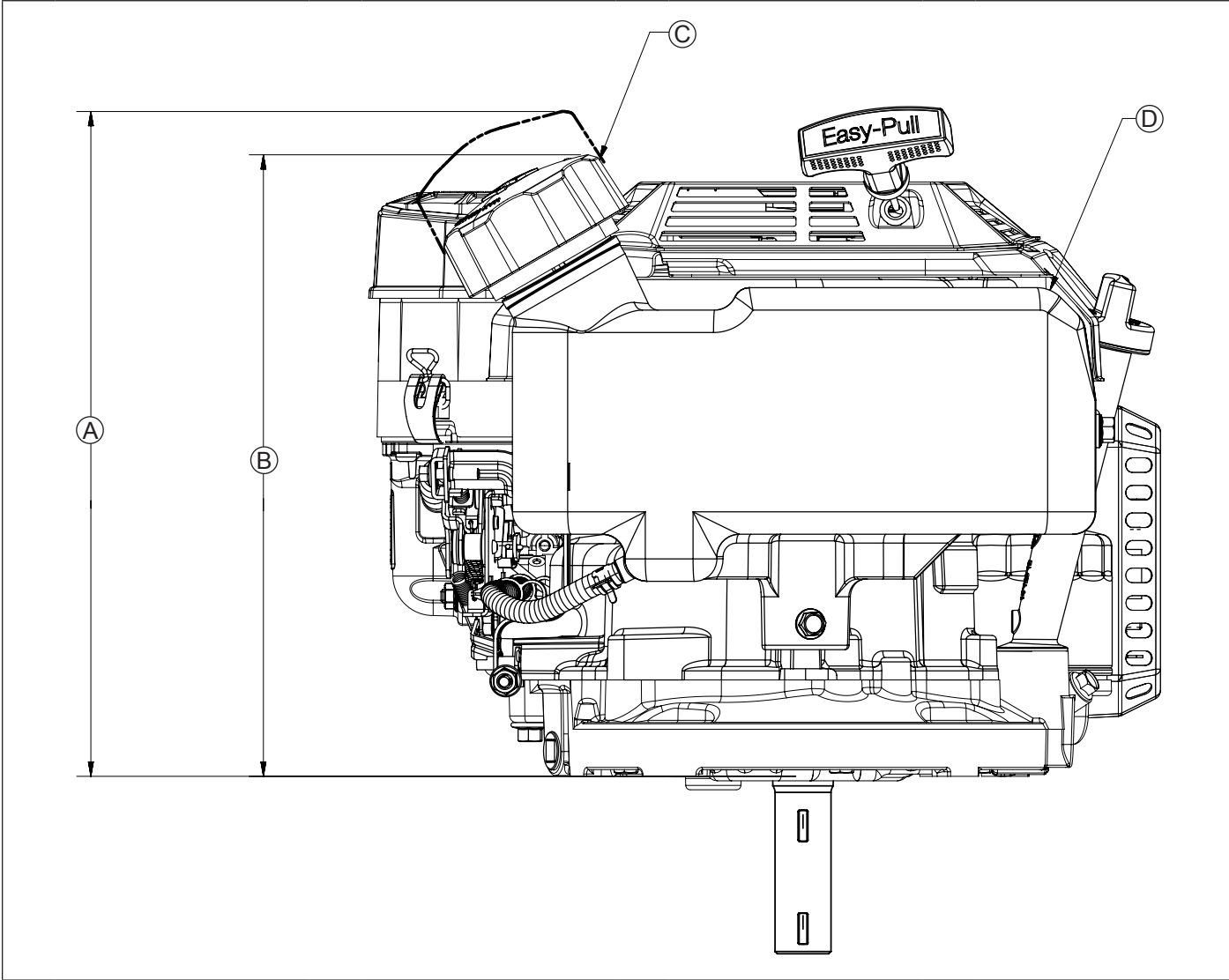

A	296.59 mm (11.677 in.) Fuel Cap Removal	B	277.28 mm (10.917 in.)	C	Fuel Cap	D	Fuel Tank
----------	--	----------	------------------------	----------	----------	----------	-----------

Specifications

CV173 Engine Dimensions-Engine Mounting Surface (PTO Side)

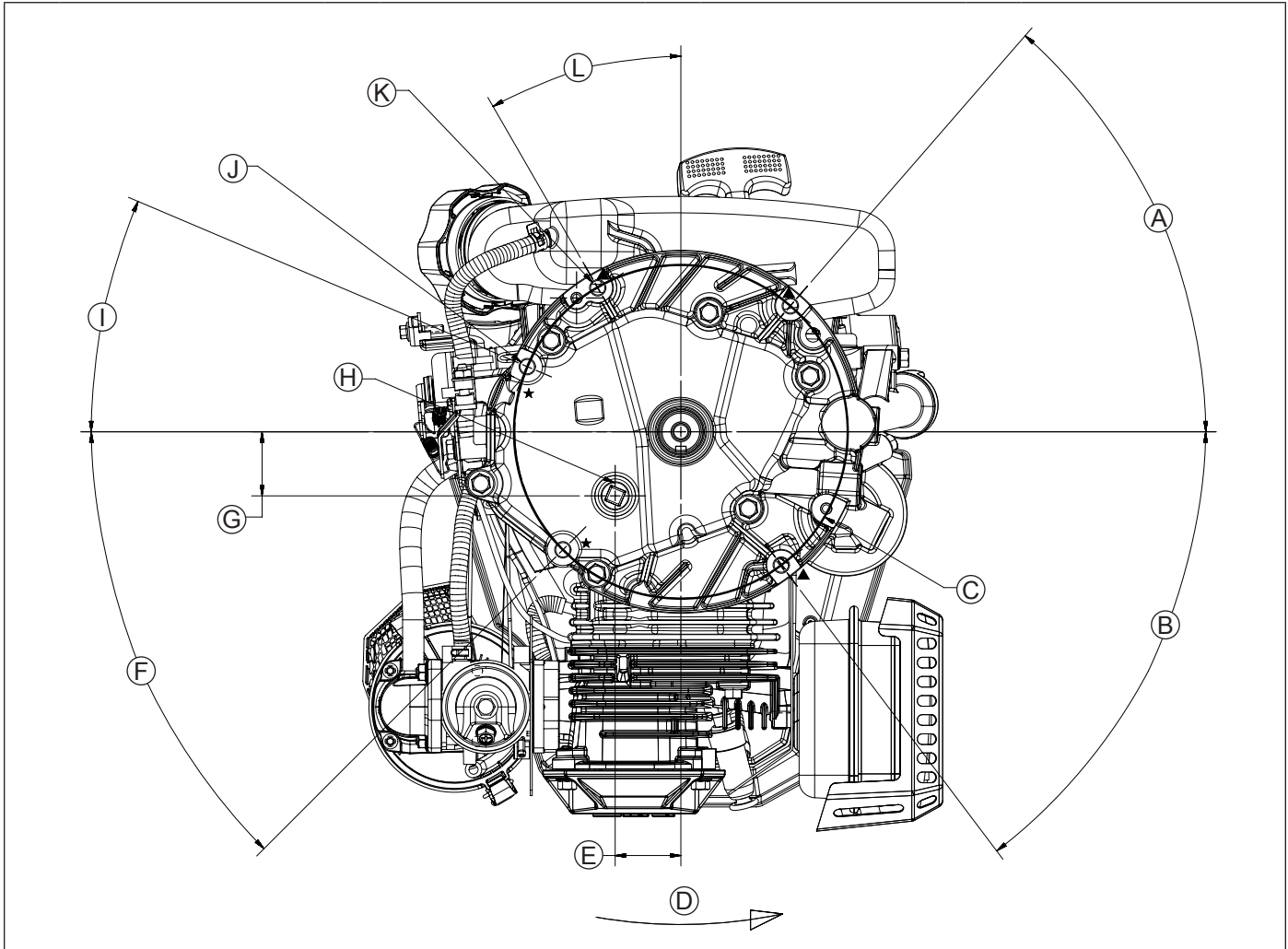

A	49°	B	53°	C	Ø 203.20 mm (8.00 in.)	D	Rotation Direction
E	40.00 mm (1.575 in.)	F	45°	G	39.00 mm (1.535 in.)	H	Optional Oil Drain Plug
I	23°	J	2 X Ø 8.75 mm (0.344 in.) 27.5 mm (1.08 in.) Deep Marked as ★	K	3 X Ø 8.75 mm (0.344 in.) Thru Marked as ▲	L	30°

CV200, CV224 Engine Dimensions-Flywheel Side

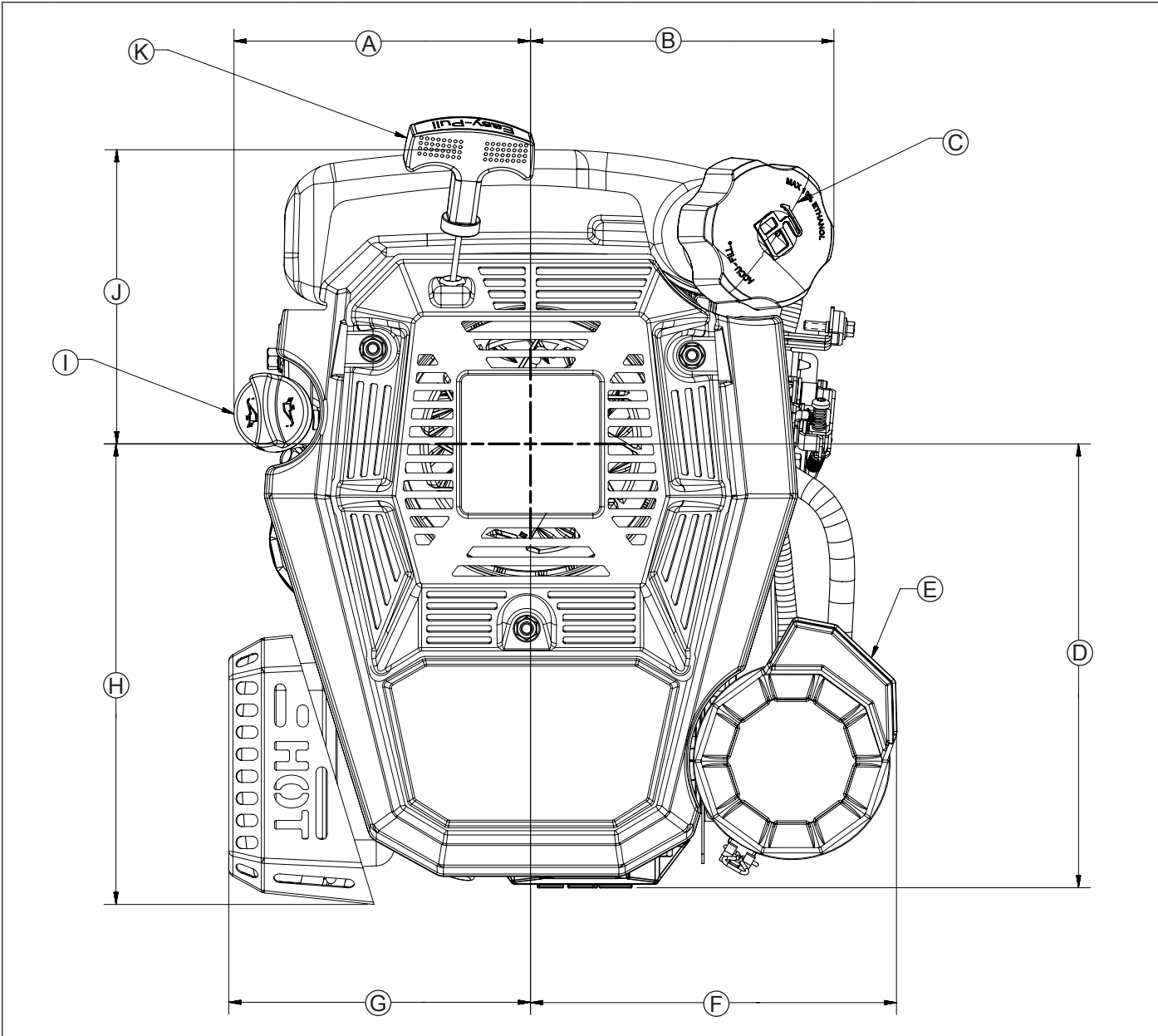

A	156.63 mm (6.167 in.)	B	160.24 mm (6.309 in.)	C	Fuel Fill	D	234.45 mm (9.230 in.)
E	Air Filter and Cover	F	193.30 mm (7.610 in.)	G	159.40 mm (6.276 in.)	H	243.27 mm (9.578 in.)
I	Oil Fill and Dipstick	J	155.35 mm (6.116 in.)	K	Recoil Rear Pull		

Specifications

CV200, CV224 Engine Dimensions-Valve Cover Side

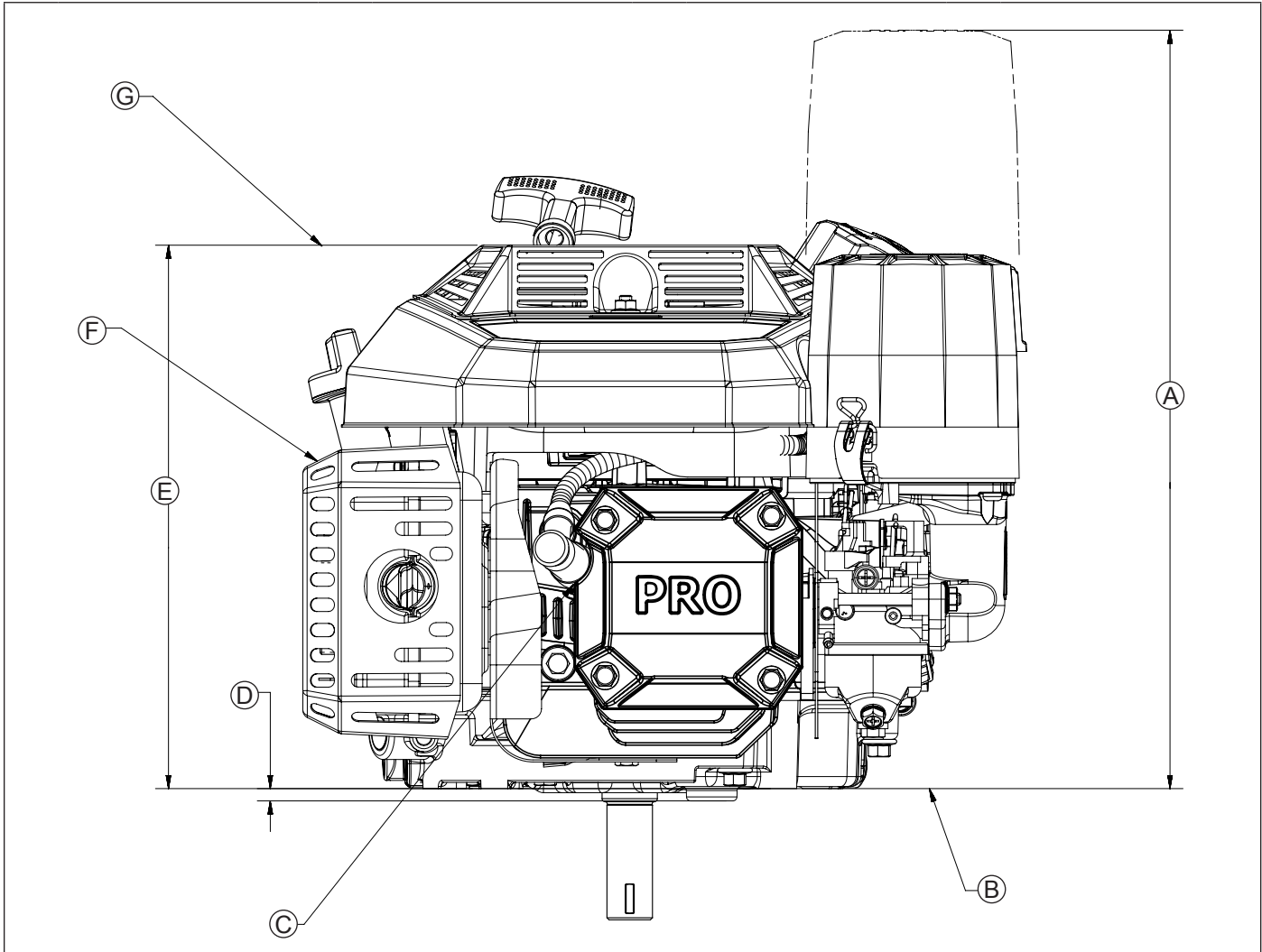

A	370.01 mm (14.567 in.) Air Cleaner Cover Removal	B	Engine Mounting Surface	C	Spark Plug	D	6.00 mm (0.236 in.)
E	265.11 mm (10.437 in.)	F	Front Exit Muffler	G	Top of Recoil		

CV200, CV224 Engine Dimensions-Fuel Tank Side

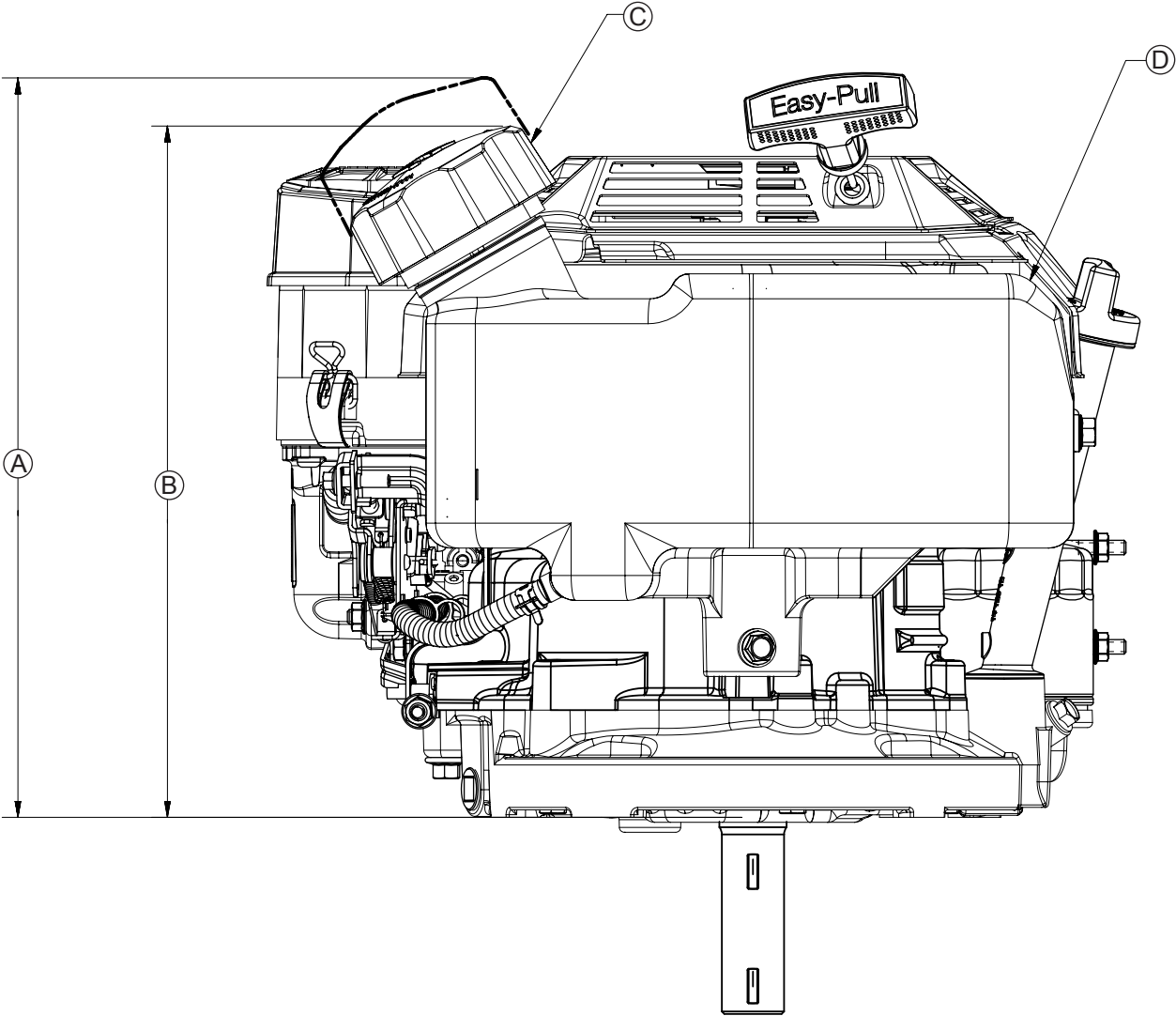

A	296.59 mm (11.677 in.) Fuel Cap Removal	B	277.28 mm (10.917 in.)	C	Fuel Cap	D	Fuel Tank
----------	--	----------	------------------------	----------	----------	----------	-----------

Specifications

CV200, CV224 Engine Dimensions-Engine Mounting Surface (PTO Side)

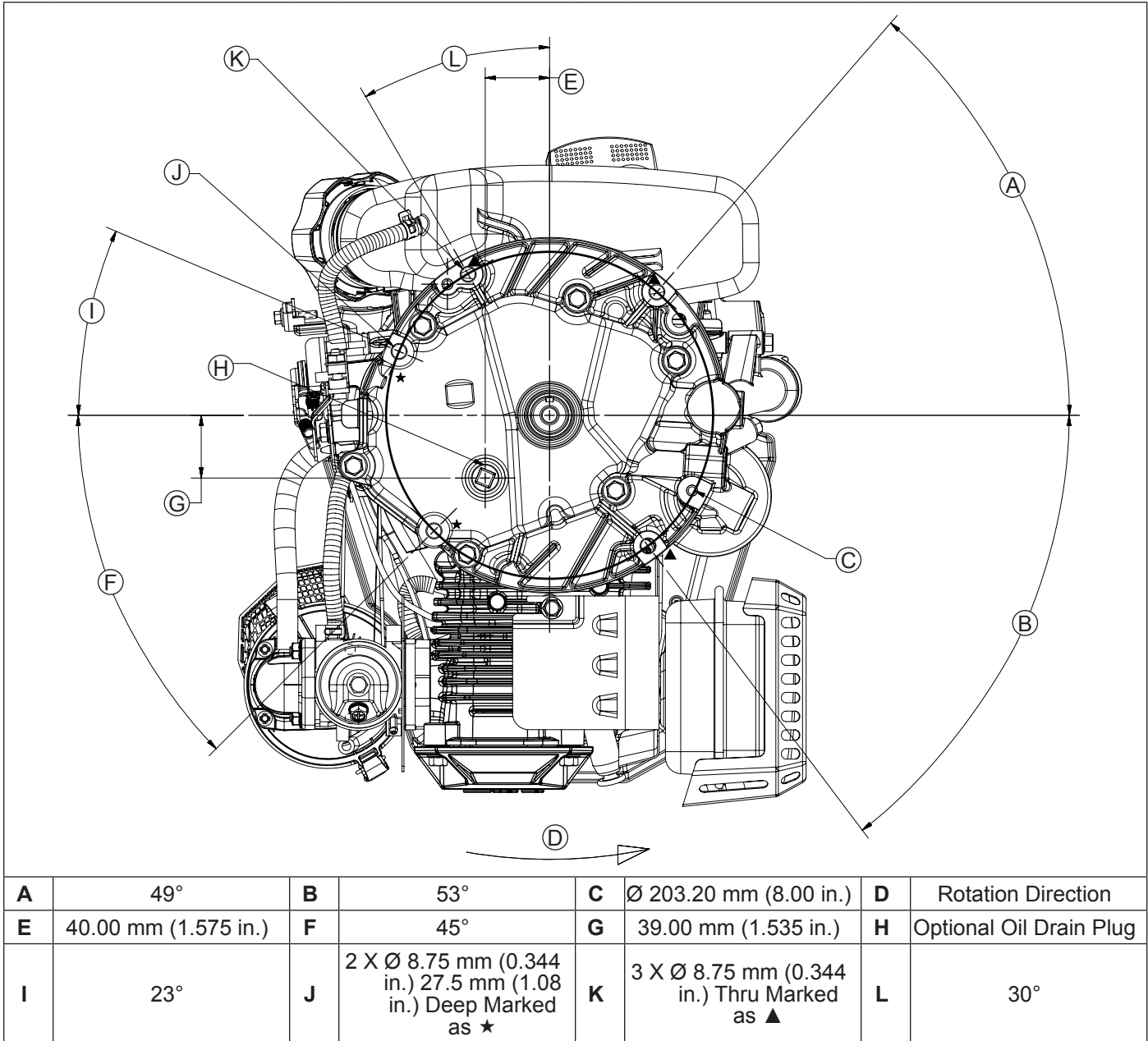

ENGINE IDENTIFICATION NUMBERS

Rehiko engine identification numbers (model, specification and serial) should be referenced for efficient repair, ordering correct parts, and engine replacement.

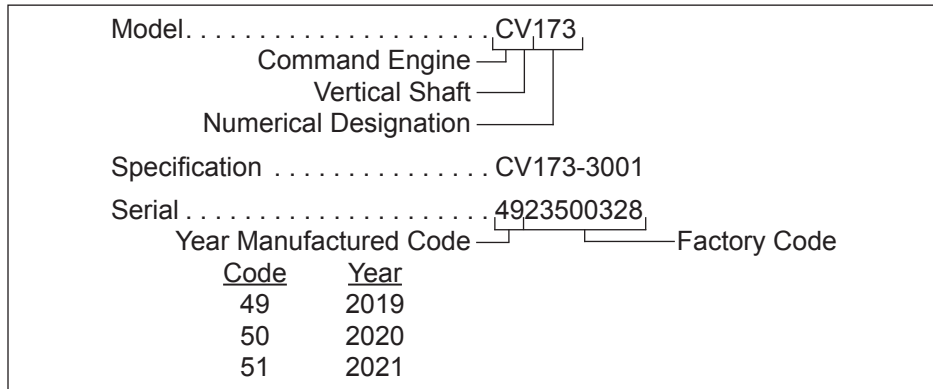

GENERAL SPECIFICATIONS^{4,6}

	CV173	CV200	CV224
Bore	70 mm (2.75 in.)	73 mm (2.87 in.)	
Stroke	45 mm (1.80 in.)	48 mm (1.89 in.)	53.5 mm (2.11 in.)
Displacement	173 cc (10.6 cu. in.)	200 cc (12.2 cu. in.)	224 cc (13.7 cu. in.)
Oil Capacity (refill)	0.70 L (24 oz.)		
Maximum Angle of Operation (@ full oil level) ⁵	25°		

TORQUE SEQUENCES

(Refer to Torque Specifications for torque values.)

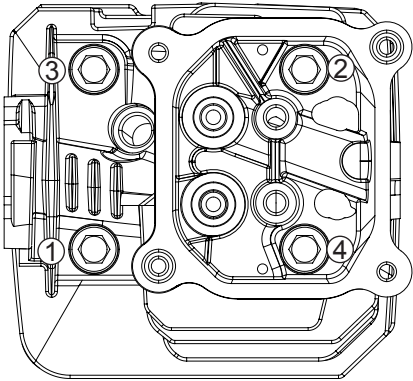
	CV173	CV200	CV224
Cylinder Head Fasteners			

⁴ Values are in Metric units. Values in parentheses are English equivalents.

⁵ Exceeding maximum angle of operation may cause engine damage from insufficient lubrication.

⁶ Any and all horsepower (hp) references by Rehiko are Certified Power Ratings and per SAE J1940 & J1995 hp standards. Details on Certified Power Ratings can be found at engines.rehiko.com.

Specifications

TORQUE SEQUENCES

CV173

CV200

CV224

Oil Pan Fasteners

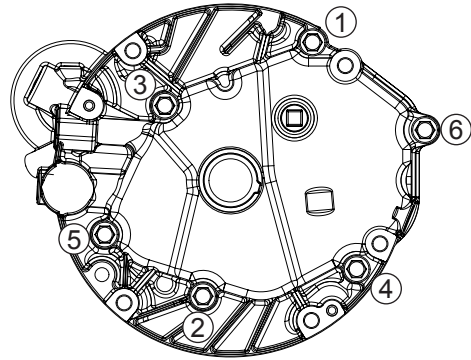

Valve Cover Fasteners

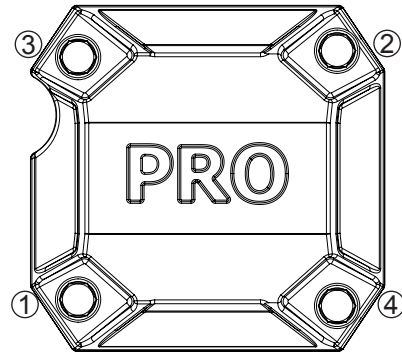

TORQUE SPECIFICATIONS^{4,7}

CV173

CV200

CV224

Air Cleaner Base to Carb Studs

Nut	8 N·m (71 in. lb.)
-----	--------------------

Blower Housing/Engine Cover/Retractable Starter

Stud	10 N·m (89 in. lb.)
------	---------------------

Brake (if equipped)

Mounting Fastener	9.5 N·m (84 in. lb.)
-------------------	----------------------

Breather Cover

Fastener	10 N·m (89 in. lb.)
----------	---------------------

Carburetor

Stud	5 N·m (44 in. lb.)
------	--------------------

Connecting Rod

Cap Fastener (torque in increments)	12.5 N·m (111 in. lb.)
-------------------------------------	------------------------

Cylinder Head (torque sequence on page 13)

Fastener (torque in 2 increments)	first to 13 N·m (115 in. lb.) finally to 25.7 N·m (227 in. lb.)
-----------------------------------	--

Dipstick Tube

Fastener	8 N·m (71 in. lb.)
----------	--------------------

⁴ Values are in Metric units. Values in parentheses are English equivalents.

⁷ Lubricate threads with engine oil prior to assembly.

TORQUE SPECIFICATIONS ^{4,7}	CV173	CV200	CV224
Finger Guard (as equipped)			
Rear Guard Fastener		10 N·m (89 in. lb.)	
Side Guard Fastener (Muffler Side, Carburetor Side)		9.5 N·m (84 in. lb.)	
Flywheel			
Retaining Nut		51.5 N·m (38 ft. lb.)	
Fuel Tank (if equipped)			
Lower Tank Bracket to Crankcase Screw		8 N·m (71 in. lb.)	
Stud		10 N·m (89 in. lb.)	
Governor			
Lever Fastener		9.5 N·m (84 in. lb.)	
Gear Fastener		9.5 N·m (84 in. lb.)	
Ignition			
Spark Plug		27 N·m (20 ft. lb.)	
Module Fasteners (Stud or Screw)		10 N·m (89 in. lb.)	
Muffler			
Exhaust Stud		5.0 N·m (44 in. lb.)	
Exhaust Nut		9.5 N·m (84 in. lb.)	
Barrel Baffle (CV200, CV224) Screw to Cylinder Head		8 N·m (71 in. lb.)	
Oil Pan (torque sequence on page 14)			
Fastener		14.7 N·m (130 in. lb.)	
Clean Oil Change Screw		14.7 N·m (130 in. lb.)	
Oil Drain Plug ⁸		13.6 N·m (120 in. lb.)	
Oil Filter Nipple		28.5 N·m (252 in. lb.)	
Oil Pump Screen Cover Fastener		9.5 N·m (84 in. lb.)	
Retractable Starter			
Fastener		8 N·m (71 in. lb.)	
Rocker Arm			
Stud		13.6 N·m (120 in. lb.)	
Pivot Jam Nut		9.5 N·m (84 in. lb.)	
Speed Control			
Bracket Assembly Fastener		8 N·m (71 in. lb.)	
Valve Cover (torque sequence on page 14)			
Fastener		8 N·m (71 in. lb.)	

⁴ Values are in Metric units. Values in parentheses are English equivalents.

⁷ Lubricate threads with engine oil prior to assembly.

⁸ Apply thread sealant around three full threads before assembly. No excess sealant allowed on inside or outside of joint. Threads with preapplied sealant do not require use of additional sealant. Approved sealants include Perma-Loc LH 150, Perma-Loc MM 115, Perma-Loc HH 120, Perma-Loc HL 126.

Specifications

CLEARANCE SPECIFICATIONS⁴

CV173

CV200

CV224

Camshaft

End Play	0.30/0.85 mm (0.0118/0.0335 in.)	
Running Clearance	0.013/0.0555 mm (0.00051/0.00217 in.)	

Connecting Rod

Connecting Rod-to-Crankpin Running Clearance New	0.025/0.045 mm (0.0009/0.0017 in.)	
Connecting Rod-to-Crankpin Side Clearance New	0.03/0.48 mm (0.00118/0.0189 in.)	0.03/0.70 mm (0.00118/0.0276 in.)
Connecting Rod-to-Piston Pin Running Clearance	0.008/0.025 mm (0.0003/0.0009 in.)	0.010/0.027 mm (0.0004/0.0011 in.)
Piston Pin End I.D. New @ 21°C (70°F)	13.006/13.017 mm (0.5120/0.5125 in.)	18.006/18.017 mm (0.7088/0.7093 in.)

Crankcase

Governor Cross Shaft Bore I.D. New	6.000/6.024 mm (0.2362/0.2372 in.)
---------------------------------------	------------------------------------

Crankshaft

End Play (free)	0.427/1.298 mm (0.0168/0.05110 in.)	0.3775/1.0975 mm (0.0149/0.0432 in.)
Bore in Oil Pan I.D.	27.050/27.071 mm (1.06496/1.06578 in.)	27.028/27.044 mm (1.0641/1.0647 in.)
Bore in Oil Pan Running Clearance	0.008/0.121 mm (0.0031/0.00476 in.)	0.058/0.094 mm (0.0023/0.0037 in.)
Bearing (flywheel) Journal O.D.	25.005/25.019 mm (0.9844/0.9850 in.)	24.975/24.989 mm (0.9832/0.9838 in.)
Max. Taper Max. Out-of-Round	0.025 mm (0.0009 in.) 0.025 mm (0.0009 in.)	
Bearing (PTO) Journal O.D. Max. Taper Max. Out-of-Round	26.95/26.97 mm (1.061/1.062 in.) 0.025 mm (0.0009 in.) 0.025 mm (0.0009 in.)	
Connecting Rod Journal O.D. New	25.985/25.995 mm (1.0230/1.0234 in.)	29.985/29.995 mm (1.18051/1.1809 in.)
Max. Taper Max. Out-of-Round	0.010 mm (0.0004 in.) 0.010 mm (0.0004 in.)	

Cylinder Bore

Bore I.D.	65.00/65.02 mm (2.559/2.560 in.)	73.020/73.036 mm (2.8748/2.8754 in.)
Max. Taper Max. Out-of-Round	0.0127 mm (0.0005 in.) 0.0127 mm (0.0005 in.)	

Cylinder Head

Max. Out-of-Flatness	0.08 mm (0.003 in.)
----------------------	---------------------

⁴ Values are in Metric units. Values in parentheses are English equivalents.

CLEARANCE SPECIFICATIONS⁴

CV173
CV200
CV224

Governor

Governor Cross Shaft-to-Crankcase Running Clearance	0.020/0.064 mm (0.0007/0.0025 in.)
Cross Shaft O.D. New	5.96/5.98 mm (0.2346/0.2354 in.)
Gear Shaft O.D. New	6.01/6.03 mm (0.2366/0.2374 in.)
Governor Gear Shaft-to-Governor Gear Running Clearance	0.09/0.19 mm (0.0035/0.0074 in.)

Ignition

Spark Plug Gap	0.76 mm (0.030 in.)
Module Air Gap	0.254 mm (0.010 in.)

Piston, Piston Rings, and Piston Pin

Pin Bore I.D.	13.002/13.008 mm (0.5118/0.5121 in.)	18.000/18.008 mm (0.7086/0.7089 in.)
Pin O.D.	12.990/12.996 mm (0.5114/0.5116 in.)	17.990/17.996 mm (0.7082/0.7085 in.)
Top and Center Compression Ring Side Clearance	0.001/0.020 mm (0.00004/0.00080 in.)	0.02/0.06 mm (0.0008/0.0024 in.)
Top and Center Compression Ring End Gap Top	0.1/0.25 mm (0.0039/0.0098 in.)	0.15/0.30 mm (0.0059/0.0118 in.)
Center	0.61/0.76 mm (0.0240/0.0299 in.)	0.20/0.35 mm (0.0079/0.0138 in.)
Thrust Face O.D.	64.975/64.985 mm (2.5580/2.5584 in.)	72.98/73.00 mm (2.8732/2.8740 in.)
Piston Thrust Face-to-Cylinder Bore Running Clearance	0.025/0.035 mm (0.0010/0.0014 in.)	0.020/0.056 mm (0.0008/0.0022 in.)



Valves and Valve Lifters

Intake and Exhaust Valve Lash	0.0762/0.1270 mm (0.003/0.005 in.)
Intake Valve Stem-to-Valve Guide Running Clearance	0.020/0.047 mm (0.0007/0.0018 in.)
Exhaust Valve Stem-to-Valve Guide Running Clearance	0.055/0.082 mm (0.0021/0.0032 in.)
Intake Valve Guide I.D.	5.500/5.512 mm (0.2165/0.2170 in.)
Intake Valve Stem Diameter	5.465/5.480 mm (0.2151/0.2157 in.)
Exhaust Valve Guide I.D.	5.500/5.512 mm (0.2165/0.2170 in.)
Exhaust Valve Stem Diameter	5.430/5.445 mm (0.2137/0.2143 in.)
Nominal Valve Face Angle	25°, 45°, 60°





⁴ Values are in Metric units. Values in parentheses are English equivalents.

Specifications

GENERAL TORQUE VALUES

English Fastener Torque Recommendations for Standard Applications				
Bolts, Screws, Nuts and Fasteners Assembled Into Cast Iron or Steel				Grade 2 or 5 Fasteners Into Aluminum
Size	 Grade 2	 Grade 5	 Grade 8	
Tightening Torque: N·m (in. lb.) ± 20%				
8-32	2.3 (20)	2.8 (25)	—	2.3 (20)
10-24	3.6 (32)	4.5 (40)	—	3.6 (32)
10-32	3.6 (32)	4.5 (40)	—	—
1/4-20	7.9 (70)	13.0 (115)	18.7 (165)	7.9 (70)
1/4-28	9.6 (85)	15.8 (140)	22.6 (200)	—
5/16-18	17.0 (150)	28.3 (250)	39.6 (350)	17.0 (150)
5/16-24	18.7 (165)	30.5 (270)	—	—
3/8-16	29.4 (260)	—	—	—
3/8-24	33.9 (300)	—	—	—

Tightening Torque: N·m (ft. lb.) ± 20%				
5/16-24	—	—	40.7 (30)	—
3/8-16	—	47.5 (35)	67.8 (50)	—
3/8-24	—	54.2 (40)	81.4 (60)	—
7/16-14	47.5 (35)	74.6 (55)	108.5 (80)	—
7/16-20	61.0 (45)	101.7 (75)	142.5 (105)	—
1/2-13	67.8 (50)	108.5 (80)	155.9 (115)	—
1/2-20	94.9 (70)	142.4 (105)	223.7 (165)	—
9/16-12	101.7 (75)	169.5 (125)	237.3 (175)	—
9/16-18	135.6 (100)	223.7 (165)	311.9 (230)	—
5/8-11	149.5 (110)	244.1 (180)	352.6 (260)	—
5/8-18	189.8 (140)	311.9 (230)	447.5 (330)	—
3/4-10	199.3 (147)	332.2 (245)	474.6 (350)	—
3/4-16	271.2 (200)	440.7 (325)	637.3 (470)	—

Metric Fastener Torque Recommendations for Standard Applications						
Size	Property Class					Noncritical Fasteners Into Aluminum
	 4.8	 5.8	 8.8	 10.9	 12.9	
Tightening Torque: N·m (in. lb.) ± 10%						
M4	1.2 (11)	1.7 (15)	2.9 (26)	4.1 (36)	5.0 (44)	2.0 (18)
M5	2.5 (22)	3.2 (28)	5.8 (51)	8.1 (72)	9.7 (86)	4.0 (35)
M6	4.3 (38)	5.7 (50)	9.9 (88)	14.0 (124)	16.5 (146)	6.8 (60)
M8	10.5 (93)	13.6 (120)	24.4 (216)	33.9 (300)	40.7 (360)	17.0 (150)
Tightening Torque: N·m (ft. lb.) ± 10%						
M10	21.7 (16)	27.1 (20)	47.5 (35)	66.4 (49)	81.4 (60)	33.9 (25)
M12	36.6 (27)	47.5 (35)	82.7 (61)	116.6 (86)	139.7 (103)	61.0 (45)
M14	58.3 (43)	76.4 (56)	131.5 (97)	184.4 (136)	219.7 (162)	94.9 (70)

Torque Conversions	
N·m = in. lb. x 0.113	in. lb. = N·m x 8.85
N·m = ft. lb. x 1.356	ft. lb. = N·m x 0.737

Certain quality tools are designed to help you perform specific disassembly, repair, and reassembly procedures. By using these tools, you can properly service engines easier, faster, and safer! In addition, you'll increase your service capabilities and customer satisfaction by decreasing engine downtime.

Here is a list of tools and their source.

NOTE: Not all tools listed are required to service this engine.

SEPARATE TOOL SUPPLIERS

Rehiko Tools
Contact your local Rehiko source of supply.

SE Tools
415 Howard St.
Lapeer, MI 48446
Phone 810-664-2981
Toll Free 800-664-2981
Fax 810-664-8181

Design Technology Inc.
768 Burr Oak Drive
Westmont, IL 60559
Phone 630-920-1300
Fax 630-920-0011

TOOLS

Description	Source/Part No.
Alcohol Content Tester For testing alcohol content (%) in reformulated/oxygenated fuels.	Rehiko 25 455 11-S
Camshaft Endplay Plate For checking camshaft endplay.	SE Tools KLR-82405
Camshaft Seal Protector (Aegis) For protecting seal during camshaft installation.	SE Tools KLR-82417
Dual Gauge Cylinder Leakdown Tester For checking combustion retention and if cylinder, piston, rings, or valves are worn. Individual component available: Adapter 12 mm x 14 mm (Required for leakdown test on XT-6 engines)	Rehiko 25 761 46-S Design Technology Inc. DTI-731-03
Dealer Tool Kit Complete kit of Rehiko required tools. Components of 25 761 39-S Ignition System Tester Dual Gauge Cylinder Leakdown Test Tool Oil Pressure Test Kit Digital Vacuum/Pressure Tester	Rehiko 25 761 39-S Rehiko 25 455 01-S Rehiko 25 761 46-S Rehiko 25 761 06-S Rehiko 25 455 22-S
Digital Vacuum/Pressure Tester For checking crankcase vacuum. Individual component available: Rubber Adapter Plug	Rehiko 25 455 22-S Design Technology Inc. DTI-721-10
EFI Service Kit For troubleshooting and setting up an EFI engine. Components of 24 761 01-S Fuel Pressure Tester Noid Light 90° Adapter Code Plug, Red Wire Code Plug, Blue Wire Code Plug, Yellow Wire Can Bus Reset Tool, Green Wire Shrader Valve Adapter Hose Wire Probe Set (2 pieces regular wire with clip; 1 piece fused wire) Hose Removal Tool, Dual Size/End (also sold as individual Rehiko tool) K-Line Adapter Jumper Lead Wiring Harness	Rehiko 24 761 01-S Design Technology Inc. DTI-019 DTI-021 DTI-023 DTI-027 DTI-029 DTI-028 DTI-030 DTI-037 DTI-031 DTI-033 Rehiko 25 176 23-S
Rehiko® Diagnostic System (KDS) Gen 2 For Laptop or Desktop PC. Components of 25 761 50-S Engine Communication Module 7 Pin to DB9 Cable USB Module to PC Cable 7 Pin to 4 Pin Adapter	Rehiko 25 761 50-S Rehiko 25 761 47-S Rehiko 25 761 48-S Rehiko 25 761 49-S Rehiko 25 761 53-S
Mobile KDS (Wireless) Module For mobile Android or iOS EFI diagnostics. Individual component available: Wireless Diagnostic System Interface Cable	Rehiko 25 761 45-S Rehiko 25 761 44-S

Tools and Aids

TOOLS

Description	Source/Part No.
Flywheel Puller For properly removing flywheel from engine.	SE Tools KLR-82408
Flywheel Anchor Bolts, Washers, Nuts Tool Used with Flywheel Puller to properly removing flywheel from 5400 Series engine.	Rehiko 25 086 753-S
Hose Removal Tool, Dual Size/End (also available in EFI Service Kit) Used to properly remove fuel hose from engine components.	Rehiko 25 455 20-S
Ignition System Tester For testing output on all systems, including CD.	Rehiko 25 455 01-S
Inductive Tachometer (Digital) For checking operating speed (RPM) of an engine.	Design Technology Inc. DTI-110
Oil Pressure Test Kit For testing/verifying oil pressure on pressure lubricated engines.	Rehiko 25 761 06-S
Rectifier-Regulator Tester (120 volt current) Rectifier-Regulator Tester (240 volt current) For testing rectifier-regulators. Components of 25 761 20-S and 25 761 41-S CS-PRO Regulator Test Harness Special Regulator Test Harness with Diode	Rehiko 25 761 20-S Rehiko 25 761 41-S Design Technology Inc. DTI-031R DTI-033R
Spark Advance Module (SAM) Tester For testing SAM (ASAM and DSAM) on engines with SMART-SPARK™.	Rehiko 25 761 40-S
Starter Servicing Kit (All Starters) For removing and reinstalling drive retaining rings and brushes. Individual component available: Starter Brush Holding Tool (Solenoid Shift)	SE Tools KLR-82411 SE Tools KLR-82416
Stepper Motor Controller Tool For testing operation of stepper motor/Digital Linear Actuator (DLA).	Rehiko 25 455 21-S
Jumper Lead Tool For use with Stepper Motor Controller Tool to test rotary stepper motor.	Rehiko 25 518 43-S
Triad/OHC Timing Tool Set For holding cam gears and crankshaft in timed position while installing timing belt.	Rehiko 28 761 01-S
Valve Guide Reamer (K and M Series) For properly sizing valve guides after installation.	Design Technology Inc. DTI-K828
Valve Guide Reamer O.S. (Command Series) For reaming worn valve guides to accept replacement oversize valves. Can be used in low-speed drill press or with handle below for hand reaming.	Rehiko 25 455 12-S
Reamer Handle For hand reaming using Rehiko 25 455 12-S reamer.	Design Technology Inc. DTI-K830

AIDS

Description	Source/Part No.
Camshaft Lubricant (Valspar ZZ613)	Rehiko 25 357 14-S
Dielectric Grease (GE/Novaguard G661)	Rehiko 25 357 11-S
Dielectric Grease	Loctite® 51360
Rehiko Electric Starter Drive Lubricant (Inertia Drive)	Rehiko 52 357 01-S
Rehiko Electric Starter Drive Lubricant (Solenoid Shift)	Rehiko 52 357 02-S
RTV Silicone Sealant Loctite® 5900® Heavy Body in 4 oz. aerosol dispenser. Only oxime-based, oil resistant RTV sealants, such as those listed, are approved for use. Permatex® the Right Stuff® 1 Minute Gasket™ or Loctite® Nos. 5900® or 5910® are recommended for best sealing characteristics. When Permatex® Ultra Grey® RTV is to be used, this will be stated in Reassembly section.	Rehiko 25 597 07-S Loctite® 5910® Loctite® Ultra Black 598™ Loctite® Ultra Blue 587™ Loctite® Ultra Copper 5920™ Permatex® the Right Stuff® 1 Minute Gasket™
Spline Drive Lubricant	Rehiko 25 357 12-S

FLYWHEEL HOLDING TOOL

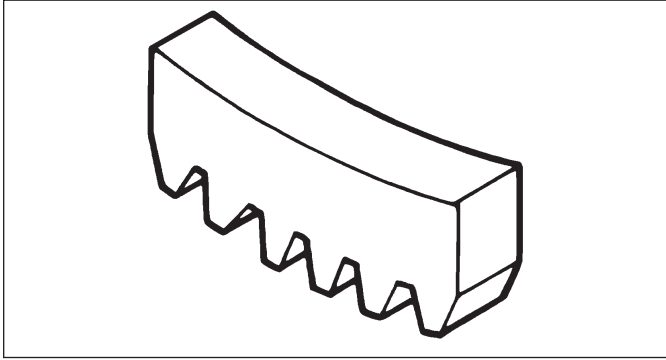

A flywheel holding tool can be made out of an old junk flywheel ring gear and used in place of a strap wrench.

1. Using an abrasive cut-off wheel, cut out a six tooth segment of ring gear as shown.
2. Grind off any burrs or sharp edges.
3. Invert segment and place it between ignition bosses on crankcase so tool teeth engage flywheel ring gear teeth. Bosses will lock tool and flywheel in position for loosening, tightening, or removing with a puller.

ROCKER ARM/CRANKSHAFT TOOL

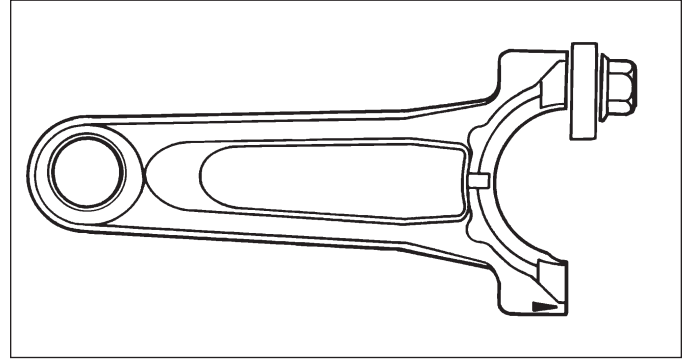

A spanner wrench to lift rocker arms or turn crankshaft may be made out of an old junk connecting rod.

1. Find a used connecting rod from a 10 HP or larger engine. Remove and discard rod cap.
2. Remove studs of a Posi-Lock rod or grind off aligning steps of a Command rod, so joint surface is flat.
3. Find a 1 in. long capscrew with correct thread size to match threads in connecting rod.
4. Use a flat washer with correct I.D. to slip on capscrew and approximately 1 in. O.D. Assemble capscrew and washer to joint surface of rod.

Troubleshooting

TROUBLESHOOTING GUIDE

When troubles occur, be sure to check simple causes which, at first, may seem too obvious to be considered. For example, a starting problem could be caused by an empty fuel tank.

Some general common causes of engine troubles are listed below and vary by engine specification. Use these to locate causing factors.

Engine Cranks But Will Not Start

- Battery connected backwards.
- Blown fuse.
- Carburetor solenoid malfunction.
- Choke not closing.
- Clogged fuel line or fuel filter.
- Diode in wiring harness failed in open circuit mode.
- Empty fuel tank.
- Faulty spark plug(s).
- Fuel pump malfunction-vacuum hose clogged or leaking.
- Fuel shut-off valve closed.
- Ignition module faulty or improperly gapped.
- Interlock switch is engaged or faulty.
- Key switch or kill switch in OFF position.
- Low oil level.
- Quality of fuel (dirt, water, stale, mixture).
- Spark plug lead(s) disconnected.

Engine Starts But Does Not Keep Running

- Faulty carburetor.
- Faulty cylinder head gasket.
- Faulty or misadjusted choke or throttle controls.
- Fuel pump malfunction-vacuum hose clogged or leaking.
- Intake system leak.
- Loose wires or connections that intermittently ground ignition kill circuit.
- Quality of fuel (dirt, water, stale, mixture).
- Restricted fuel tank cap vent.

Engine Starts Hard

- Clogged fuel line or fuel filter.
- Engine overheated.
- Faulty ACR mechanism.
- Faulty or misadjusted choke or throttle controls.
- Faulty spark plug(s).
- Flywheel key sheared.
- Fuel pump malfunction-vacuum hose clogged or leaking.
- Interlock switch is engaged or faulty.
- Loose wires or connections that intermittently ground ignition kill circuit.
- Low compression.
- Quality of fuel (dirt, water, stale, mixture).
- Weak spark.

Engine Will Not Crank

- Battery is discharged.
- Faulty electric starter or solenoid.
- Faulty key switch or ignition switch.
- Interlock switch is engaged or faulty.
- Loose wires or connections that intermittently ground ignition kill circuit.
- Pawls not engaging in drive cup.
- Seized internal engine components.

Engine Runs But Misses

- Carburetor adjusted incorrectly.
- Engine overheated.
- Faulty spark plug.
- Ignition module faulty or improperly gapped.
- Incorrect crankshaft position sensor air gap.
- Interlock switch is engaged or faulty.
- Loose wires or connections that intermittently ground ignition kill circuit.
- Quality of fuel (dirt, water, stale, mixture).
- Spark plug lead boot loose on plug.
- Spark plug lead loose.

Engine Will Not Idle

- Engine overheated.
- Faulty spark plug.
- Idle fuel circuit in carburetor plugged/restricted
- Idle speed adjusting screw improperly set.
- Inadequate fuel supply.
- Low compression.
- Quality of fuel (dirt, water, stale, mixture).
- Restricted fuel tank cap vent.

Engine Overheats

- Cooling fan broken.
- Excessive engine load.
- High crankcase oil level.
- Lean fuel mixture.
- Low crankcase oil level.
- Cooling system components clogged or restricted.

Engine Knocks

- Excessive engine load.
- Incorrect oil viscosity/type.
- Internal wear or damage.
- Low crankcase oil level.
- Quality of fuel (dirt, water, stale, mixture).

Engine Loses Power

- Dirty air cleaner element.
- Engine overheated.
- Excessive engine load.
- Restricted exhaust.
- Faulty spark plug.
- High crankcase oil level.
- Incorrect governor setting.
- Low battery.
- Low compression.
- Low crankcase oil level.
- Quality of fuel (dirt, water, stale, mixture).

Engine Uses Excessive Amount of Oil

- Loose or improperly torqued fasteners.
- Blown head gasket/overheated.
- Breather reed broken.
- Clogged, broken, or inoperative crankcase breather.
- Crankcase overfilled.
- Incorrect oil viscosity/type.
- Worn cylinder bore.
- Worn or broken piston rings.
- Worn valve stems/valve guides.

Oil Leaks from Oil Seals, Gaskets

- Breather reed broken.
- Clogged, broken, or inoperative crankcase breather.
- Loose or improperly torqued fasteners.
- Piston blow by, or leaky valves.
- Restricted exhaust.

EXTERNAL ENGINE INSPECTION

NOTE: It is good practice to drain oil at a location away from workbench. Be sure to allow ample time for complete drainage.

Before cleaning or disassembling engine, make a thorough inspection of its external appearance and condition. This inspection can give clues to what might be found inside engines (and cause) when it is disassembled.

- Check for buildup of dirt and debris on crankcase, cooling fins, grass screen, and other external surfaces. Dirt or debris on these areas can cause overheating.
- Check for obvious fuel and oil leaks, and damaged components. Excessive oil leakage can indicate a clogged or inoperative breather, worn or damaged seals or gaskets, or loose fasteners.
- Check air cleaner cover and base for damage or indications of improper fit and seal.
- Check air cleaner element. Look for holes, tears, cracked or damaged sealing surfaces, or other damage that could allow unfiltered air into engine. A dirty or clogged element could indicate insufficient or improper maintenance.
- Check carburetor throat for dirt. Dirt in throat is further indication that air cleaner was not functioning properly.
- Check if oil level is within operating range on dipstick. If it is above, sniff for gasoline odor.
- Check condition of oil. Drain oil into a container; it should flow freely. Check for metal chips and other foreign particles.

Sludge is a natural by-product of combustion; a small accumulation is normal. Excessive sludge formation could indicate over rich fuel settings, weak ignition, overextended oil change interval or wrong weight or type of oil was used.

CLEANING ENGINE

	⚠ WARNING
	<p>Cleaning Solvents can cause severe injury or death.</p> <p>Use only in well ventilated areas away from ignition sources.</p>
<p>Carburetor cleaners and solvents are extremely flammable. Follow cleaner manufacturer's warnings and instructions on its proper and safe use. Never use gasoline as a cleaning agent.</p>	

After inspecting external condition of engine, clean engine thoroughly before disassembly. Clean individual components as engine is disassembled. Only clean parts can be accurately inspected and gauged for wear or damage. There are many commercially available cleaners that will quickly remove grease, oil, and grime from engine parts. When such a cleaner is used, follow manufacturer's instructions and safety precautions carefully.

Make sure all traces of cleaner are removed before engine is reassembled and placed into operation. Even small amounts of these cleaners can quickly break down lubricating properties of engine oil.

Troubleshooting

CRANKCASE VACUUM TEST

	⚠ WARNING
	Carbon Monoxide can cause severe nausea, fainting or death. Avoid inhaling exhaust fumes. Never run engine indoors or in enclosed spaces.
Engine exhaust gases contain poisonous carbon monoxide. Carbon monoxide is odorless, colorless, and can cause death if inhaled.	

	⚠ WARNING
	Rotating Parts can cause severe injury. Stay away while engine is in operation.
Keep hands, feet, hair, and clothing away from all moving parts to prevent injury. Never operate engine with covers, shrouds, or guards removed.	

A partial vacuum should be present in crankcase when engine is operating. Pressure in crankcase (normally caused by a clogged or improperly assembled breather) can cause oil to be forced out at oil seals, gaskets, or other available spots.

Crankcase vacuum is best measured with either a water manometer or a vacuum gauge (inches of water gauge only). Complete instructions are provided in kits.

To test crankcase vacuum with manometer:

1. Insert rubber stopper into oil fill hole. Be sure pinch clamp is installed on hose and use tapered adapters to connect hose between stopper and one manometer tube. Leave other tube open to atmosphere. Check that water level in manometer is at 0 line. Make sure pinch clamp is closed.
2. Start engine and run no-load high speed.
3. Open clamp and note water level in tube.
Level in engine side should be a minimum of 10.2 cm (4 in.) above level in open side.
If level in engine side is less than specified (low/no vacuum), or level in engine side is lower than level in open side (pressure), check for conditions in table below.
4. Close pinch clamp before stopping engine.

To test crankcase vacuum with vacuum/pressure gauge (inches of water gauge only):

1. Remove dipstick or oil fill plug/cap.
2. Install adapter into oil fill//dipstick tube opening, upside down over end of a small diameter dipstick tube, or directly into engine if a tube is not used. Insert barbed gauge fitting into hole in stopper.
3. Run engine and observe gauge reading.
Analog tester—needle movement to left of 0 is a vacuum, and movement to right indicates a pressure.
Digital tester—depress test button on top of tester.
Crankcase vacuum should be a minimum of 10.2 cm (4 in.) of water. If reading is below specification, or if pressure is present, check table below for possible causes and conclusions.

Condition	Conclusion
Crankcase breather clogged or inoperative.	NOTE: If breather is integral part of valve cover and cannot be serviced separately, replace valve cover and recheck pressure. Disassemble breather, clean parts thoroughly, check sealing surfaces for flatness, reassemble, and recheck pressure.
Seals and/or gaskets leaking. Loose or improperly torque fasteners.	Replace all worn or damaged seals and gaskets. Make sure all fasteners are tightened securely. Use appropriate torque values and sequences when necessary.
Piston blow by or leaky valves (confirm by inspecting components).	Recondition piston, rings, cylinder bore, valves and valves guides.
Restricted exhaust.	Check exhaust screen/spark arrestor (if equipped). Clean or replace as needed. Repair or replace any other damaged/restricted muffler or exhaust system parts.

COMPRESSION TEST

A compression test is best performed on a warm engine. Clean any dirt or debris away from base of spark plug before removing it. Be sure battery is fully charged, choke is off, and throttle is wide open during test. Compression should be at least 160 psi and should not vary more than 15% between cylinders.

Some models (recoil start) may be equipped with an automatic compression release (ACR) mechanism. It is difficult to obtain an accurate compression reading because of ACR mechanism. As an alternative, use cylinder leakdown test described below.

CYLINDER LEAKDOWN TEST

A cylinder leakdown test can be a valuable alternative to a compression test. By pressurizing combustion chamber from an external air source you can determine if valves or rings are leaking, and how badly.

Cylinder leakdown tester is a relatively simple, inexpensive leakdown tester for small engines. This tester includes a quick-connect for attaching adapter hose and a holding tool.

Dual Gauge Test Procedure

1. Run engine until oil temperature reaches and maintains 150°F (66°C) or more for a minimum of 5 minutes. Ideally, engine should be run under normal load conditions.
2. Remove spark plug(s) and air filter from engine.
3. Rotate crankshaft until piston (of cylinder being tested) is at top dead center (TDC) of compression stroke. Hold engine in this position while testing. Holding tool from kit can be used if PTO end of crankshaft is accessible. Lock holding tool onto crankshaft. Install a 3/8 in. breaker bar into hole/slot of holding tool, so it is perpendicular to both holding tool and crankshaft PTO.

If flywheel end is more accessible, use a breaker bar and socket on flywheel nut/screw to hold it in position. An assistant may be needed to hold breaker bar during testing. If engine is mounted in a piece of equipment, it may be possible to hold it by clamping or wedging a driven component. Just be certain engine cannot rotate off TDC in either direction.

4. Connect an air source (at least 100 PSI) to tool.
5. Turn regulator knob clockwise (increase direction). Confirm both gauges read approximately the same air pressure from 0 to 80 PSI. Note any discrepancies between gauges for leakage calculation. Release pressure by turning regulator knob completely counterclockwise before proceeding.
6. Install adapter hose into spark plug hole of cylinder being tested. Use 12 mm x 14 mm adapter if required.
7. Firmly hold engine at TDC. Connect other end of adapter hose to tool quick connect. Turn regulator knob clockwise (increase direction) until left gauge needle reads 20 PSI.

NOTE: When piston is at TDC, little to no holding force should be required when air pressure is applied to cylinder. If excess holding force is required, this indicates piston is not at TDC. Readjust as necessary before proceeding.

8. Slowly turn regulator knob clockwise until left hand gauge maintains selected test pressure (see chart below).

Left Gauge Regulated Pressure Selection
<p>80 PSI Recommended for engines over 200 cc or those exhibiting high leakage at 35 PSI setting.</p>
<p>35 PSI Recommended for single cylinder walk-behind push mower applications.</p>

9. Compare right gauge reading to Test Pressure Chart on next page to identify percentage of leakage. Also refer to Leakdown Test Results chart on next page for colors, conditions, and action required.
10. For engines exhibiting leakage in yellow or red zone, repeat test procedure. Operate engine under normal load conditions prior to test. Confirm piston is at TDC during test.

NOTE: To prevent damage to gauge assembly, always turn pressure regulator knob to zero (counterclockwise) after each test.

Troubleshooting

Test Pressure Chart for Dual Gauge Tool

Left Gauge Regulated Pressure Selection	Right Gauge Reading in PSI											
80 PSI Recommended for engines over 200 cc or those exhibiting high leakage at 35 PSI setting.	80	72	64	56	48	40	32	24	16	8	0	
35 PSI Recommended for single cylinder walk-behind push mower applications.	35	31.5	28	24.5	21	17.5	14	10.5	7	3.5	0	
Percentage of leakage	0%	10%	20%	30%	40%	50%	60%	70%	80%	90%	100%	
	Green Zone				Yellow Zone				Red Zone			

Leakdown Test Results

Test Result	Condition	Action
Gauge reading in low (green) zone.	Piston rings and cylinder in good condition.	No further action required.
Gauge reading in moderate (yellow) zone.	Air escaping from crankcase breather and/or dipstick tube.	Some wear present causing leakage from combustion chamber to crankcase. Repair not required at this time if breather system is functioning normally.
	Air escaping from exhaust.	Exhaust valve leakage present, possibly due to carbon deposits. Repair not required. Carbon cleaning could be performed to reduce leakage.
	Air escaping from intake.	Intake valve leakage present, possibly due to carbon deposits. Repair not required. Carbon cleaning could be performed to reduce leakage.
Gauge reading in high (red) zone. Confirm consecutive leakdown test has been performed AFTER engine has been operated under normal load conditions.	Air escaping from crankcase breather and/or dipstick tube.	Excess wear present causing leakage from combustion chamber to crankcase. Breather system will not function normally and will fail crankcase vacuum test if this condition is truly present. Engine disassembly and analysis required to determine root cause and correction.
	Air escaping from exhaust.	Excess exhaust valve leakage present, possibly due to carbon deposits and/or valve to seat sealing issues. Carbon cleaning may reduce leakage. Valve grind and/or component replacement may be necessary. Excess oil consumption and/or excess heat is a suspect cause and must be resolved to prevent reoccurrence.
	Air escaping from intake.	Excess intake valve leakage present, possibly due to carbon deposits and/or valve to seat sealing issues. Carbon cleaning may reduce leakage. Valve grind and/or component replacement may be necessary. Excess oil consumption through intake valve and/or excess heat is a suspect cause and must be resolved to prevent reoccurrence. Inspect breather system components and intake valve stem sealing.

AIR CLEANER

These systems are CARB/EPA certified and components should not be altered or modified in any way.

Air Cleaner Components

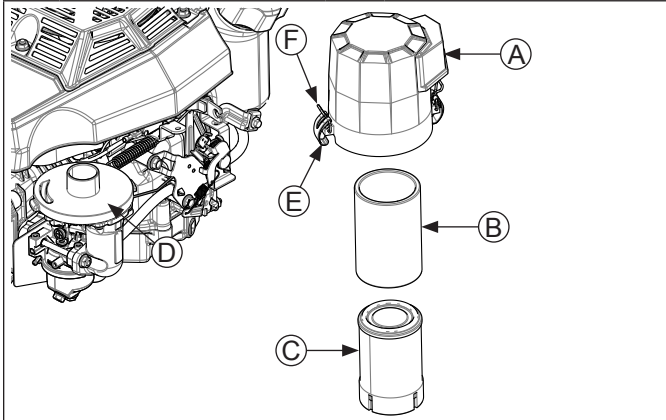

A	Air Cleaner Cover	B	Precleaner
C	Paper Element	D	Base
E	Latch	F	Bail

NOTE: Operating engine with loose or damaged air cleaner components could cause premature wear and failure. Replace all bent or damaged components.

NOTE: Paper element cannot be blown out with compressed air.

Move bails on air cleaner cover down; remove latches from under tabs on base; remove cover.

Precleaner (if equipped)

1. Remove precleaner from paper element.
2. Replace or wash precleaner in warm water with detergent. Rinse and allow to air dry.
3. Lightly oil precleaner with new engine oil; squeeze out excess oil.
4. Reinstall precleaner over paper element.

Paper Element

1. Separate precleaner from element; service precleaner and replace paper element.
2. Install new paper element on base; install precleaner over paper element.

Reinstall air cleaner cover and place latches under tabs on base; lift up bails to secure cover.

BREATHER TUBE

Make sure both ends of breather tube are properly connected.

AIR COOLING

	WARNING
	<p>Hot Parts can cause severe burns. Do not touch engine while operating or just after stopping.</p>
<p>Never operate engine with heat shields or guards removed.</p>	

Proper cooling is essential. To prevent over heating, clean screens, cooling fins, and other external surfaces of engine. Avoid spraying water at wiring harness or any electrical components. Refer to Maintenance Schedule.

Fuel System

Typical carbureted fuel system and related components include:

- Fuel tank (if equipped).
- Fuel line.
- In-line fuel filter (if equipped).
- Fuel tank filter (in-nipple).
- Carburetor.

Fuel tank outlet is located above carburetor inlet, allowing gravity to feed fuel through in-line filter and fuel line to carburetor.

Fuel then enters carburetor float bowl. Fuel is drawn into carburetor body and is mixed with air. This fuel-air mixture is then burned in engine combustion chamber.

FUEL RECOMMENDATIONS

Refer to Maintenance.

FUEL LINE

Low permeation fuel line must be installed on carbureted Rehlko engines to maintain EPA and CARB regulatory compliance.

FUEL SYSTEM TESTS

When engine starts hard, or turns over but will not start, fuel system might be causing problems. Test fuel system by performing following tests.

1. Check for fuel in combustion chamber.
 - a. Disconnect and ground spark plug lead.
 - b. Close choke on carburetor.
 - c. Crank engine several times.
 - d. Remove spark plug and check for fuel at tip.
2. Check for fuel flow from tank to carburetor.
 - a. Remove fuel line from inlet fitting of carburetor.
 - b. Use an approved fuel container to catch fuel, and hold line below bottom of tank to observe fuel flow.

Condition	Conclusion
Fuel at tip of spark plug.	Fuel is reaching combustion chamber.
No fuel at tip of spark plug.	Check fuel flow from fuel tank (step 2).
Fuel flows from fuel line.	Check for faulty carburetor, refer to Carburetor.
No fuel flow from fuel line.	Check fuel tank vent, outlet filter threaded into tank, and fuel line. Correct any observed problem and reconnect line.
Fuel line condition.	Check for clogged fuel line.

CARBURETOR

	⚠ WARNING	Gasoline is extremely flammable and its vapors can explode if ignited. Store gasoline only in approved containers, in well ventilated, unoccupied buildings, away from sparks or flames. Spilled fuel could ignite if it comes in contact with hot parts or sparks from ignition. Never use gasoline as a cleaning agent.
	Explosive Fuel can cause fires and severe burns. Do not fill fuel tank while engine is hot or running.	

Typical One-Barrel Carburetor Components

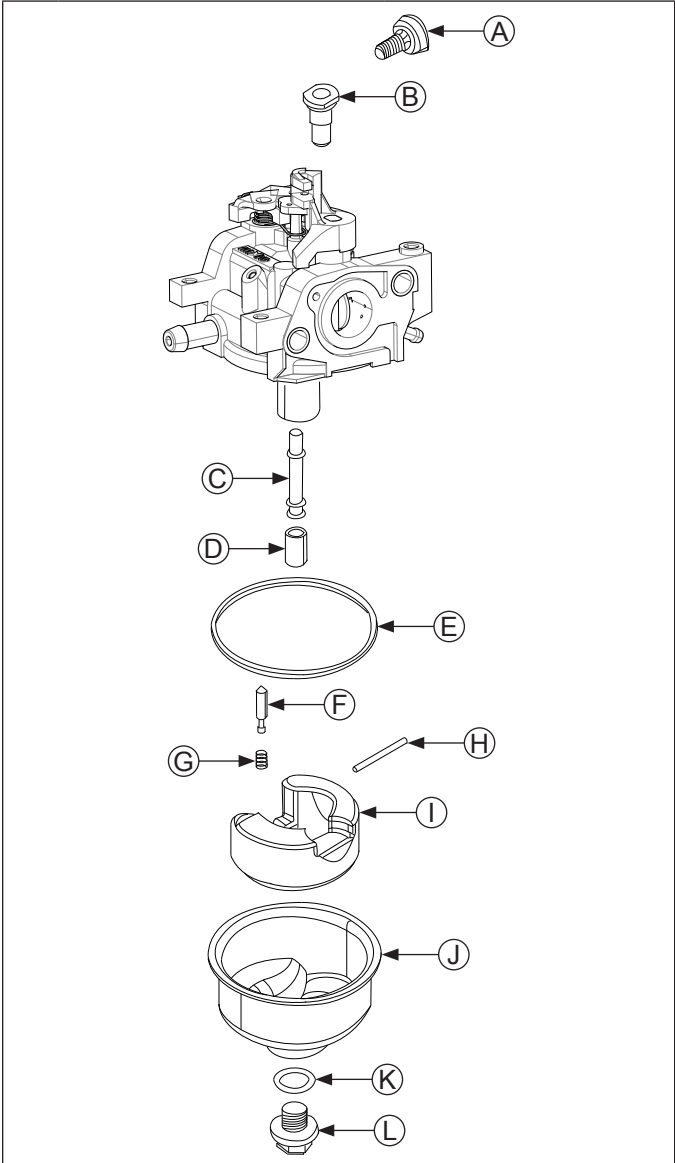

A	Low Idle Speed Adjusting Screw	B	Idle Jet
C	Main Nozzle Tube	D	Main Jet
E	Bowl Gasket	F	Fuel Inlet Needle
G	Spring	H	Hinge Pin
I	Float	J	Fuel Bowl
K	Bowl Retaining Screw Gasket	L	Bowl Retaining Screw

These engines are equipped with a fixed main jet carburetor. Carburetor is designed to deliver correct fuel-to-air mixture to engine under all operating conditions. Idle mixture is set at factory and cannot be adjusted.

Troubleshooting Checklist

- When engine starts hard, runs rough, or stalls at low idle speed, check these areas before adjusting or disassembling carburetor.
1. Make sure fuel tank is filled with clean, fresh gasoline.
 2. Make sure fuel tank cap vent is not blocked and is operating properly.
 3. Make sure fuel is reaching carburetor. This includes checking fuel tank filter screen, in-line fuel filter, and fuel lines for restrictions or faulty components as necessary.
 4. Make sure air cleaner base and carburetor are securely fastened to engine using gaskets in good condition.
 5. Make sure air cleaner element (including pre-cleaner if equipped) is clean and all air cleaner components are fastened securely.
 6. Make sure ignition system, governor system, exhaust system, and throttle and choke controls are operating properly.

Fuel System

Troubleshooting-Carburetor Related Causes

Condition	Possible Cause	Conclusion
Engine starts hard, runs rough, or stalls at idle speed.	Low idle speed improperly adjusted.	Adjust idle speed screw or clean carburetor.
Engine runs rich (indicated by black, sooty exhaust smoke, misfiring, loss of speed and power, governor hunting, or excessive throttle opening).	Clogged air cleaner.	Clean or replace air cleaner.
	Choke partially closed during operation.	Check choke lever/linkage to ensure choke is operating properly.
	Dirt under fuel inlet needle.	Remove needle; clean needle and seat and blow with compressed air.
	Bowl vent or air bleeds plugged.	Clean vent, ports, and air bleeds. Blow out all passages with compressed air.
	Leaky, cracked, or damaged float.	Submerge float to check for leaks.
Engine runs lean (indicated by misfiring, loss of speed and power, governor hunting, or excessive throttle opening).	Idle holes plugged; dirt in fuel delivery channels.	Clean main fuel jet and all passages; blow out with compressed air.
Fuel leaks from carburetor.	Float damaged.	Submerge float to check for leaks. Replace float.
	Dirt under fuel inlet needle.	Remove needle; clean needle and seat and blow with compressed air.
	Bowl vents plugged.	Blow out with compressed air.
	Carburetor bowl gasket leaks.	Replace gasket.

Carburetor Circuits

Float

Fuel level in bowl is maintained by float and fuel inlet needle. Buoyant force of float stops fuel flow when engine is at rest. When fuel is being consumed, float will drop and fuel pressure will push inlet needle away from seat, allowing more fuel to enter bowl. When demand ceases, buoyant force of float will again overcome fuel pressure, rising to predetermined setting and stop flow.

Slow and Mid-Range

At low speeds engine operates only on slow circuit. As a metered amount of air is drawn through slow air bleed jets, fuel is drawn through main jet and further metered through slow jet. Air and fuel are mixed in body of slow jet and exit to idle progression (transfer port) chamber. From idle progression chamber, air fuel mixture is metered through idle port passage. At low idle air/fuel mixture is controlled by setting of idle fuel adjusting screws. This mixture is then mixed with main body of air and delivered to engine. As throttle plate opening increases, greater amounts of air/fuel mixture are drawn in through fixed and metered idle progression holes. As throttle plate opens further, vacuum signal becomes great enough at venturi so main circuit begins to work.

Main (high-speed)

At high speeds/loads engine operates on main circuit. As a metered amount of air is drawn through air jet, fuel is drawn through main jet. Air and fuel are mixed in main nozzles then enters main body of airflow where further mixing of fuel and air occurs. This mixture is then delivered to combustion chamber. Carburetor has a fixed main circuit; no adjustment is possible.

Carburetor Adjustments

NOTE: Carburetor adjustments should be made only after engine has warmed up.





Carburetor is designed to deliver correct fuel-to-air mixture to engine under all operating conditions. Main fuel jet is calibrated at factory and is not adjustable. Idle fuel adjusting needles are also set at factory and are not adjustable.

Low Idle Speed (RPM) Adjustment

NOTE: Actual low idle speed depends on application. Refer to equipment manufacturer's recommendations. Low idle speed for basic engines is 1800 RPM.

Place throttle control into idle or slow position. Turn low idle speed adjusting screw in or out to obtain allow idle speed of 1800 RPM (\pm 75 RPM).

Carburetor Servicing

  	 WARNING
	<p>Accidental Starts can cause severe injury or death.</p> <p>Disconnect and ground spark plug lead(s) before servicing.</p>
<p>Before working on engine or equipment, disable engine as follows: 1) Disconnect spark plug lead(s). 2) Disconnect negative (-) battery cable from battery.</p>	

NOTE: Main and slow jets are fixed and size specific and can be removed if required. Fixed jets for high altitudes are available.

- Inspect carburetor body for cracks, holes, and other wear or damage.
- Inspect float for cracks, holes, and missing or damaged float tabs. Check float hinge and shaft for wear or damage.
- Inspect fuel inlet needle and seat for wear or damage.

1. Perform removal procedures for appropriate air cleaner and carburetor outlined in Disassembly.
2. Clean exterior surfaces of dirt or foreign material before disassembling carburetor. Remove bowl retaining screw, and carefully separate fuel bowl from carburetor. Do not damage fuel bowl O-ring. Transfer any remaining fuel into an approved container. Save all parts. Fuel can also be drained prior to bowl removal by loosening/removing bowl drain screw.
3. Remove float pin and inlet needle. Seat for inlet needle is not serviceable and should not be removed.
4. Clean carburetor bowl and inlet seat areas as required.
5. Carefully remove main jet from carburetor. After main jet is removed, main nozzle can be removed through bottom of main tower. Note orientation/direction of nozzle. End with 2 raised shoulders should be out/down adjacent to main jet.
6. Save parts for cleaning and reuse unless a jet kit is also being installed. Clean slow jet using compressed air or carburetor cleaner, do not use wire.

NOTE: There are 2 O-rings on body of idle jet.

Carburetor is now disassembled for appropriate cleaning and installation of parts in overhaul kit.

High Altitude Operation

If this engine is operated at an altitude of 4000 ft. (1219 meters) or above, a high altitude carburetor kit is required. To obtain high altitude carburetor kit information or to find a Rehlko authorized dealer, visit Engines.rehlko.com or call 1-800-544-2444 (U.S. and Canada).

This engine should be operated in its original configuration below 4000 ft. (1219 meters).

Operating this engine with the wrong engine configuration at a given altitude may increase its emissions, decrease fuel efficiency and performance, and result in damage to the engine.

Governor System

GOVERNOR

Governor Components

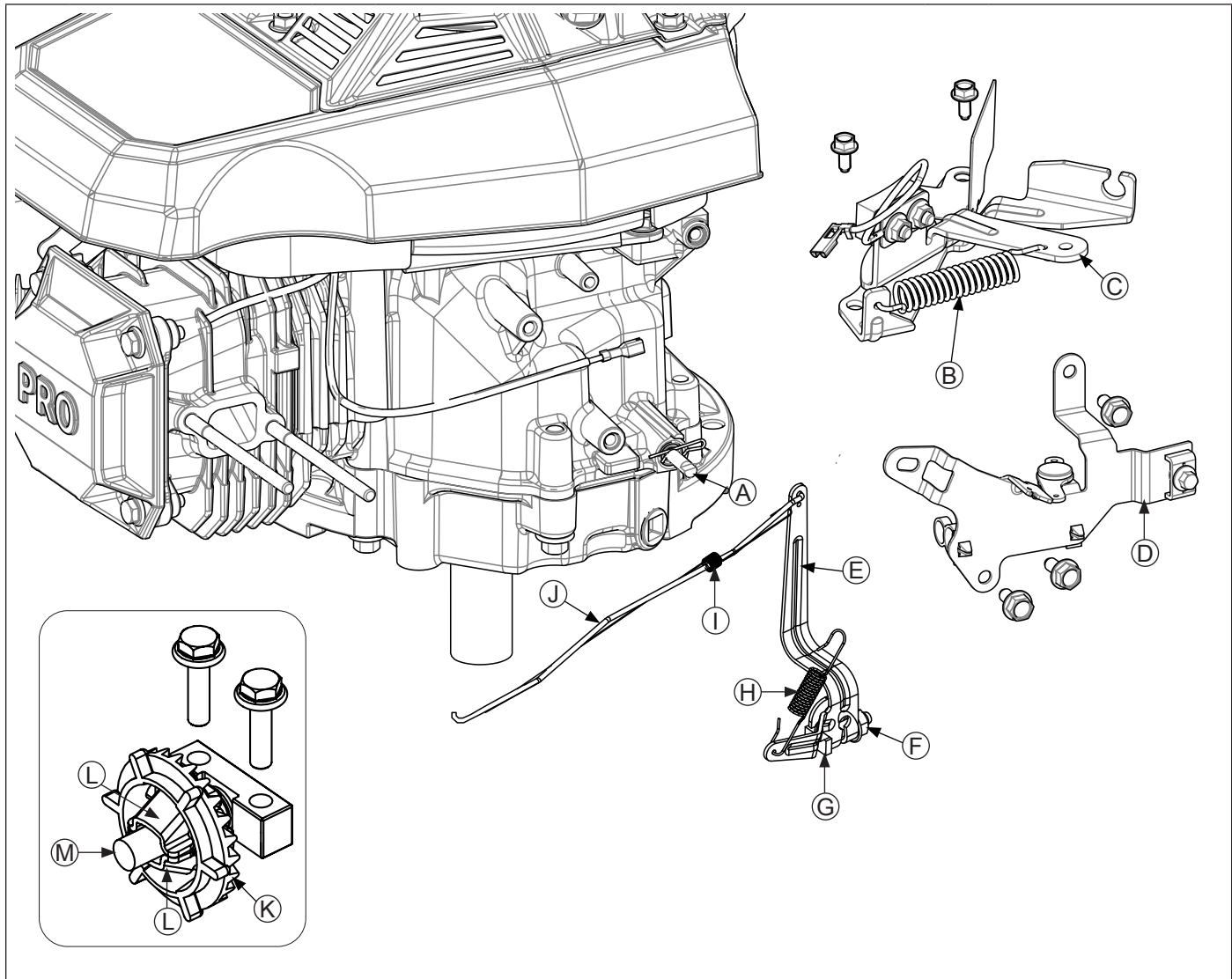

A	Governor Cross Shaft	B	Brake Spring (if equipped)	C	Brake Lever (if equipped)	D	Control Bracket
E	Governor Lever	F	Nut	G	Screw	H	Governor Spring
I	Throttle Linkage Spring	J	Throttle Linkage	K	Governor Gear Assembly	L	Flyweights
M	Regulating Pin						

Governed speed setting is determined by position of throttle control. It can be variable or constant, depending on engine application.

Governor is designed to hold engine speed constant under changing load conditions. These engines are equipped with a centrifugal flyweight mechanical governor. Governor gear/flyweight mechanism of mechanical governor is mounted inside oil pan and is driven off gear on camshaft.

This governor design works as follows:

- Centrifugal force acting on rotating governor gear assembly causes flyweights to move outward as speed increases. Governor spring tension moves them inward as speed decreases.
- As flyweights move outward, they cause regulating pin to move outward.
- Regulating pin contacts tab on cross shaft causing shaft to rotate.
- One end of cross shaft protrudes through crankcase. Rotating action of cross shaft is transmitted to throttle lever of carburetor through external throttle linkage.

- When engine is at rest, and throttle is in fast position, tension of governor spring holds throttle plate open. When engine is operating, governor gear assembly is rotating. Force applied by regulating pin against cross shaft tends to close throttle plate. Governor spring tension and force applied by regulating pin balance each other during operation, to maintain engine speed.
- When load is applied and engine speed and governor gear speed decreases, governor spring tension moves governor arm to open throttle plate wider. This allows more fuel into engine, increasing engine speed. As speed reaches governed setting, governor spring tension and force applied by regulating pin will again offset each other to hold a steady engine speed.

Initial Governor Adjustment

Make this initial adjustment whenever governor arm is loosened or removed from cross shaft. To ensure proper adjustment, make sure throttle linkage is connected to both governor arm and throttle lever on carburetor.

1. Loosen nut holding governor lever to cross shaft.
2. Move governor lever away from carburetor (wide open throttle) and hold in this position. Do not apply excess force that may flex or distort throttle link.
3. Grasp cross shaft with a pliers and turn shaft clockwise as far as it will go, hold and tighten nut. Then torque nut to 9.5 N·m (84 in. lb.).

Lubrication System

This engine uses a combination pressure/splash lubrication system, delivering oil under pressure to crankshaft, connecting rod and main bearing surfaces. Other component areas are splash lubricated.

Lubrication Components

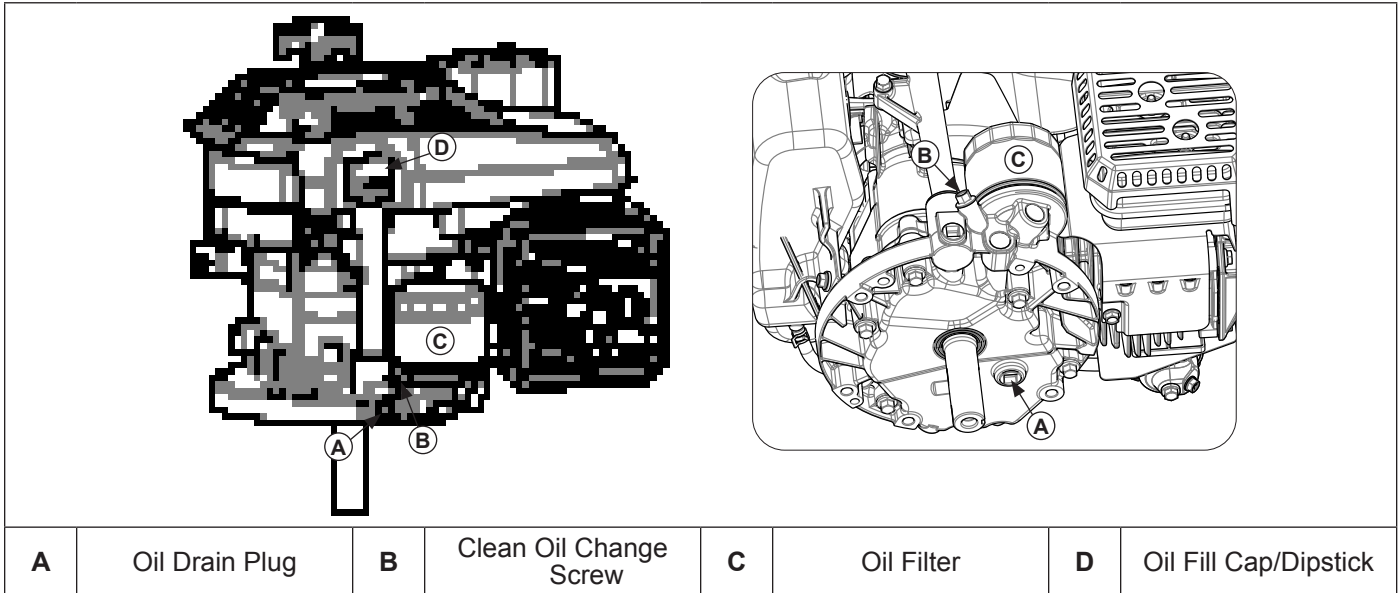

OIL RECOMMENDATIONS

Refer to Maintenance.

CHECK OIL LEVEL

NOTE: To prevent extensive engine wear or damage, never run engine with oil level below or above operating range indicator on dipstick.

Ensure engine is cool and level. Clean oil fill cap/dipstick areas of any debris.

1. Remove dipstick; wipe oil off.
2. Reinsert dipstick into tube; press completely down and turn 1/4 turn.
3. Remove dipstick; check oil level. Level should be at top of indicator on dipstick.
4. If oil is low on indicator, add oil up to top of indicator mark.
5. Reinstall and secure dipstick.

CHANGE OIL AND OIL FILTER

Change oil while engine is warm.

1. Clean area around oil fill cap/dipstick and drain plug. Remove drain plug and oil fill cap/dipstick; drain oil into appropriate container.
2. Clean area around oil filter. Remove clean oil change screw; then slowly remove filter; wipe off mounting surface.
3. Apply thread sealant around three full threads of drain plug; reinstall drain plug. Torque to 13.6 N·m (120 in. lb.).
4. Reinstall clean oil change screw. Torque to 14.7 N·m (130 in. lb.).
5. Apply a thin film of clean oil to rubber gasket on new filter.

6. Refer to instructions on oil filter for proper installation.
7. Fill crankcase with new oil. Level should be at top of indicator on dipstick.
8. Reinstall oil fill cap/dipstick and tighten securely.
9. Start engine; check for oil leaks. Stop engine; correct leaks. Recheck oil level.
10. Dispose of used oil and filter in accordance with local ordinances.

SPARK PLUGS



⚠ CAUTION

Electrical Shock can cause injury.
Do not touch wires while engine is running.

Spark Plug Component and Details

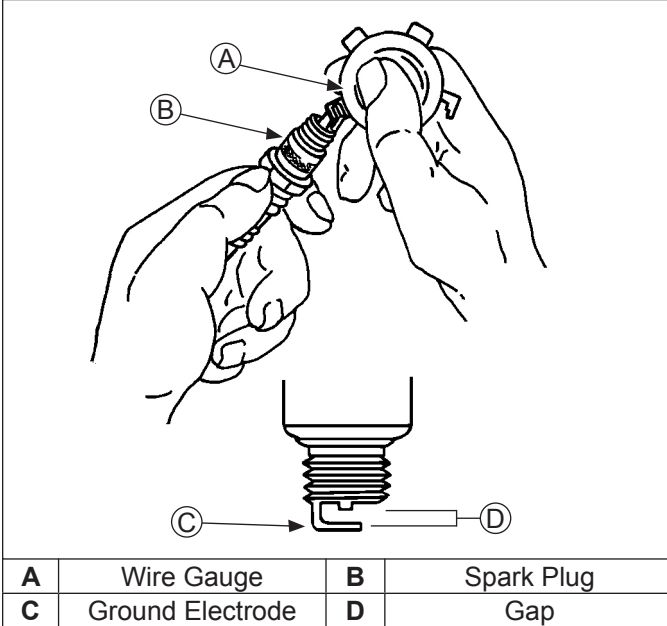

A	Wire Gauge	B	Spark Plug
C	Ground Electrode	D	Gap

NOTE: Do not clean spark plug in a machine using abrasive grit. Some grit could remain in spark plug and enter engine causing extensive wear and damage.

Engine misfire or starting problems are often caused by a spark plug that has improper gap or is in poor condition.

Engine is equipped with following spark plugs:

Gap	0.76 mm (0.030 in.)
Thread Size	12 mm
Reach	19.1 mm (3/4 in.)
Hex Size	18 mm (3/4 in.)

Refer to Maintenance for Repairs/Service Parts.

Service

Clean out spark plug recess. Remove plug and replace.

1. Check gap using wire feeler gauge. Adjust gap to 0.76 mm (0.030 in.).
2. Install plug into cylinder head.
3. Torque plug to 27 N·m (20 ft. lb.).

Inspection

Inspect each spark plug as it is removed from cylinder head. Deposits on tip are an indication of general condition of piston rings, valves, and carburetor.

Normal and fouled plugs are shown in following photos:

Normal



Plug taken from an engine operating under normal conditions will have light tan or gray colored deposits. If center electrode is not worn, plug can be set to proper gap and reused.

Worn



On a worn plug, center electrode will be rounded and gap will be greater than specified gap. Replace a worn spark plug immediately.

Wet Fouled



A wet plug is caused by excess fuel or oil in combustion chamber. Excess fuel could be caused by a restricted air cleaner, a carburetor problem, or operating engine with too much choke. Oil in combustion chamber is usually caused by a restricted air cleaner, a breather problem, worn piston rings, or valve guides.

Electrical System

Carbon Fouled



Soft, sooty, black deposits indicate incomplete combustion caused by a restricted air cleaner, over rich carburetion, weak ignition, or poor compression.

Overheated



Chalky, white deposits indicate very high combustion temperatures. This condition is usually accompanied by excessive gap erosion. Lean carburetor settings, an intake air leak, or incorrect spark timing are normal causes for high combustion temperatures.

ELECTRONIC IGNITION SYSTEM

Inductive Discharge Ignition System Components

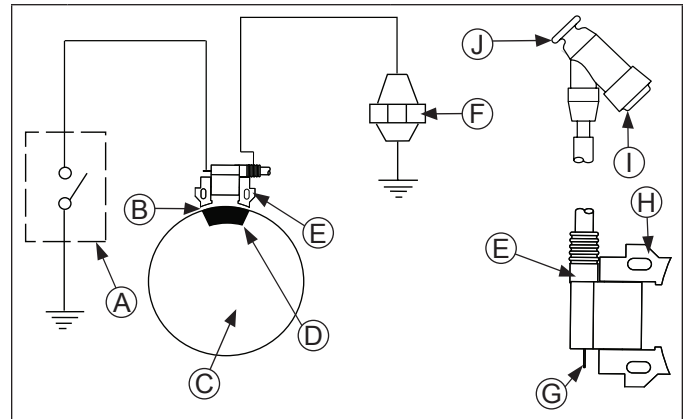

A	Ignition Kill Switch	B	Air Gap 0.254 mm (0.010 in.)
C	Flywheel	D	Magnet
E	Ignition Module	F	Spark Plug
G	Kill Terminal	H	Lamination
I	Spark Plug Terminal	J	Spark Plug Boot

These engines are equipped with a dependable solid-state magneto ignition system. In such a system, as flywheel rotates and magnet passes ignition module, magnetic field induces current in primary coil. As ignition magnet completes its pass, it induces current in a small triggering coil, which then turns on a semiconductor switch. This causes previously induced magnetic field in primary coil to collapse. As magnetic field collapses, it causes voltage in secondary coil to rise quickly. This sharp rise in voltage is sufficient to arc across gap at spark plug and ignite fuel mixture in combustion chamber.

This ignition system is designed to be trouble free for life of engine. Other than periodically checking/replacing spark plugs, no maintenance or timing adjustments are necessary or possible. Mechanical systems do occasionally fail or break down. Refer to Troubleshooting to determine root of a reported problem.

Reported ignition problems are most often due to poor connections. Before beginning test procedure, check all external wiring. Be certain all ignition-related wires are connected, including spark plug leads. Be certain all terminal connections fit snugly.

Electronic Ignition Systems Tests

Test Ignition System

1. Make sure spark plug lead is connected to spark plug.
2. Check condition of spark plug. Make sure gap is set to 0.76 mm (0.030 in.).

Condition	Possible Cause	Conclusion
Spark plug is not receiving ignition pulse.	Spark Plug	Check gap and adjust if necessary; reinstall plug.
Spark plug in bad condition.	Spark Plug	Replace plug, set gap, and install.

Test Ignition Module

1. Disconnect kill lead from terminal on ignition module.
2. Pull retractable starter to a minimum of 350-450 RPM and check for spark.

Condition	Possible Cause	Conclusion
Visible and audible sparks are produced.	Ignition System or Wiring and Connections	Problem is elsewhere in system/wiring.
Visible and audible sparks are not produced.	Ignition Module	Replace ignition module.

Starter System

RETRACTABLE STARTERS

	⚠ WARNING
	<p>Uncoiling Spring can cause severe injury. Wear safety goggles or face protection when servicing retractable starter.</p>
<p>Retractable starters contain a powerful, recoil spring that is under tension. Always wear safety goggles when servicing retractable starters and carefully follow instructions in Retractable Starter for relieving spring tension.</p>	

Engines in this series use retractable starters.

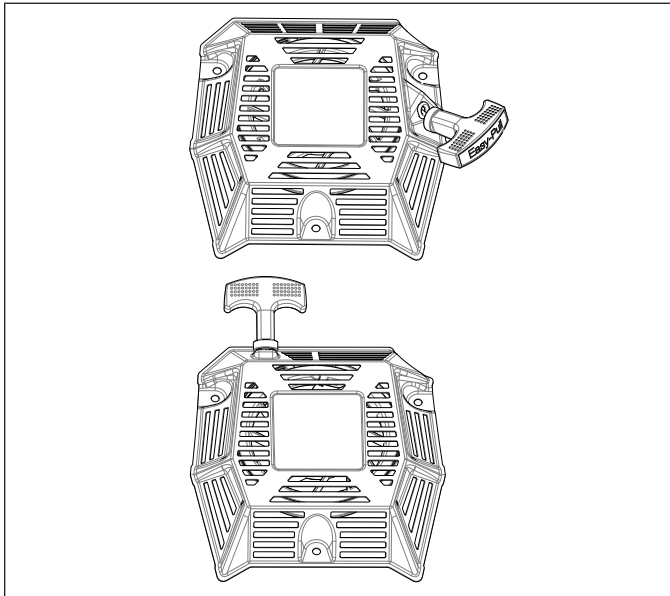

Retractable Starter Components

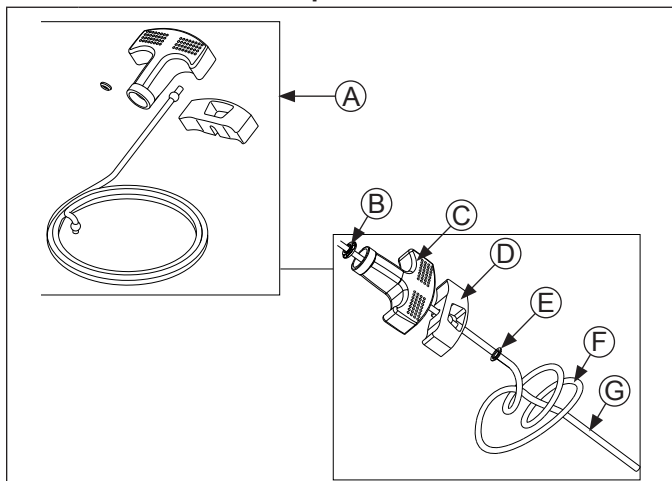

A	Starter Rope with Handle Kit	B	Grommet
C	Starter Handle	D	Handle Retainer
E	Rope Retainer	F	Double Left-Hand Knot
G	Starter Rope		

Remove Starter

NOTE: Whenever possible, an impact wrench should be used to loosen nuts securing retractable starter.

1. Remove nuts securing starter to engine cover.
2. Remove starter assembly.

Rope Replacement

NOTE: Do not allow pulley/spring to unwind. Enlist aid of a helper if necessary.

Rope can be replaced without complete starter disassembly.

1. Remove starter assembly from engine.
2. Pull rope out approximately 12 in. and tie a temporary (slip) knot in it to keep it from retracting into starter.
3. Pull knot end out of handle, untie knot, and slide handle off.
4. Hold pulley firmly and untie slipknot. Allow pulley to rotate slowly as spring tension is released.
5. When all spring tension on starter pulley is released, remove rope from pulley.
6. Tie a double left-hand knot in one end of new rope.
7. Rotate pulley counterclockwise to pre-tension spring (approximately 4 full turns of pulley).
8. Continue rotating pulley counterclockwise until rope hole in pulley is aligned with rope guide bushing of starter housing.
9. Insert unknotted end of new rope through rope hole in starter pulley and rope guide bushing of housing.
10. Tie a slipknot approximately 12 in. from free end of rope. Hold pulley firmly and allow it to rotate slowly until slipknot reaches guide bushing of housing.
11. Insert starter rope through starter handle and tie a double, left-hand knot at end of starter rope. Insert knot into hole in handle.
12. Untie slip knot and pull on starter handle until starter rope is fully extended. Slowly retract starter rope into starter assembly. If recoil spring is properly tensioned, starter rope will retract fully and starter handle will stop against starter housing.

Install Starter

1. Place starter onto studs protruding from engine cover. Start nuts onto studs, but do not tighten.
2. Pull starter handle out until pawls engage in drive cup. Hold handle in this position and torque nuts to 8 N·m (71 in. lb.).

Disassembly/Inspection and Service

	⚠ WARNING	Before working on engine or equipment, disable engine as follows: 1) Disconnect spark plug lead(s). 2) Disconnect negative (-) battery cable from battery.
	Accidental Starts can cause severe injury or death. Disconnect and ground spark plug lead(s) before servicing.	

Clean all parts thoroughly as engine is disassembled. Only clean parts can be accurately inspected and gauged for wear or damage. There are many commercially available cleaners that will quickly remove grease, oil, and grime from engine parts. When such a cleaner is used, follow manufacturer's instructions and safety precautions carefully.

Make sure all traces of cleaner are removed before engine is reassembled and placed into operation. Even small amounts of these cleaners can quickly break down lubricating properties of engine oil.

Empty Fuel Tank (if equipped)

Ensure fuel tank is empty by running engine until it stops, and is completely out of fuel.

Disconnect Spark Plug

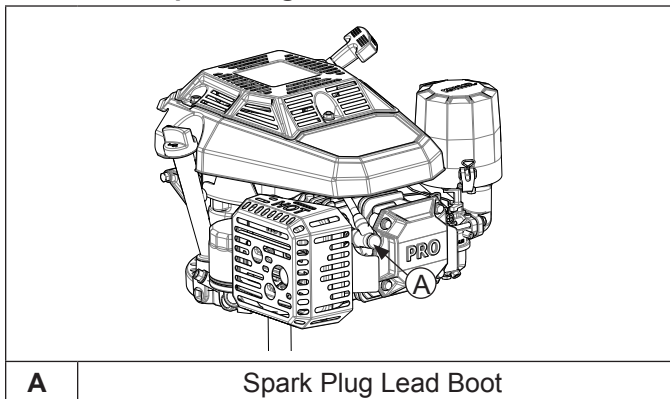

A	Spark Plug Lead Boot
----------	----------------------

NOTE: Pull on boot only, to prevent damage to spark plug lead.

Disconnect lead from spark plug.

Drain Oil and Remove Oil Filter

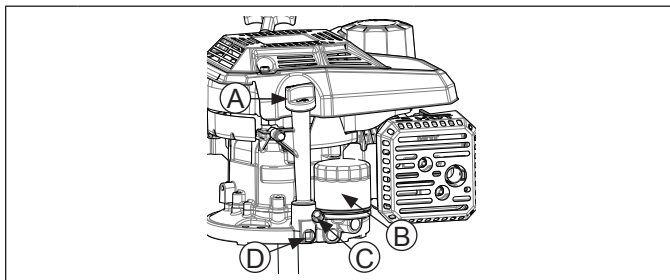

A	Oil Fill Cap/Dipstick	B	Oil Filter
C	Clean Oil Change Screw	D	Drain Plug

1. Clean area around oil fill cap/dipstick and drain plug. Remove drain plug and oil fill cap/dipstick; drain oil into an approved container.
2. Clean area around oil filter. Remove clean oil change screw; then slowly remove filter; wipe off mounting surface.

3. Dispose of used oil and filter in accordance with local ordinances.

Remove Air Cleaner Assembly

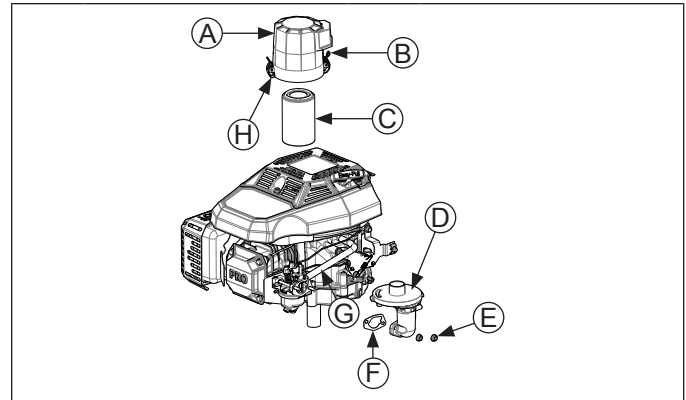

A	Air Cleaner Cover	B	Bail
C	Paper Element and Foam Precleaner	D	Air Cleaner Base Assembly
E	Nut	F	Gasket
G	Breather Hose	H	Latch

1. Move bails on air cleaner cover down; remove latches from under tabs on base; remove cover.
2. Remove paper element and foam precleaner (if equipped).
3. Using Hose Removal Tool (See Tools and Aids), carefully remove breather hose from air cleaner base assembly.
4. Remove nuts securing air cleaner base assembly to carburetor; remove assembly from studs and discard gasket.

Disassembly/Inspection and Service

Remove Carburetor

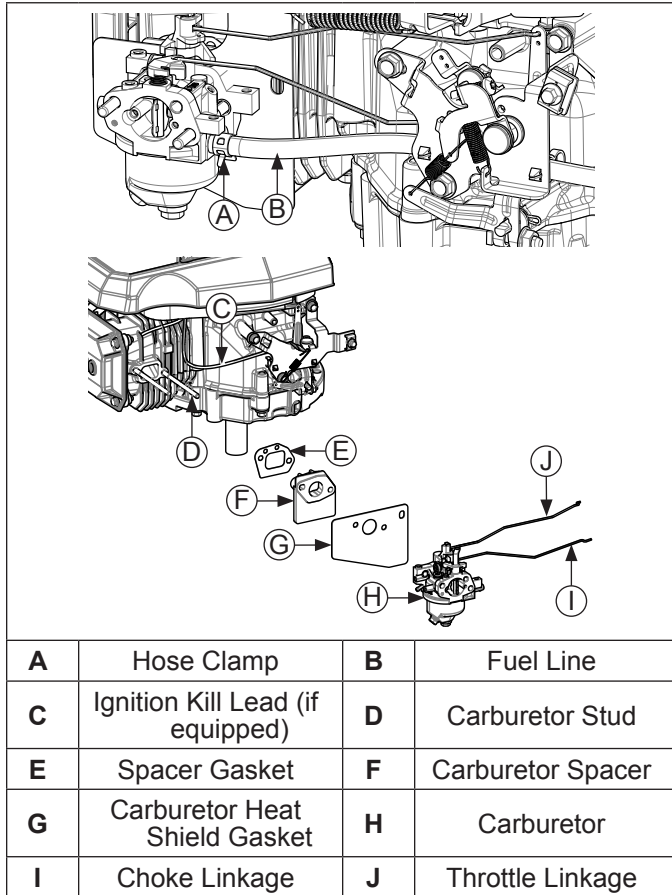

NOTE: Ensure fuel tank is empty by running engine until it stops, and is completely out of fuel.

1. Squeeze hose clamp and slide it up on fuel line (away from carburetor). Using Hose Removal Tool (see Tools and Aids) carefully remove fuel line from carburetor.
2. Turn throttle lever clockwise until it stops. Gently push rod and spring linkages up to disconnect them from throttle lever.
3. Move throttle control clockwise to full choke position, and slide carburetor off studs while disconnecting choke linkage from carburetor.
4. If equipped, disconnect ignition kill lead terminal from stop switch on speed control assembly.
5. Remove carburetor heat shield gasket sliding off lead (if equipped); discard gasket.
6. Remove carburetor spacer and spacer gasket from studs; discard gasket.

Remove Control Components

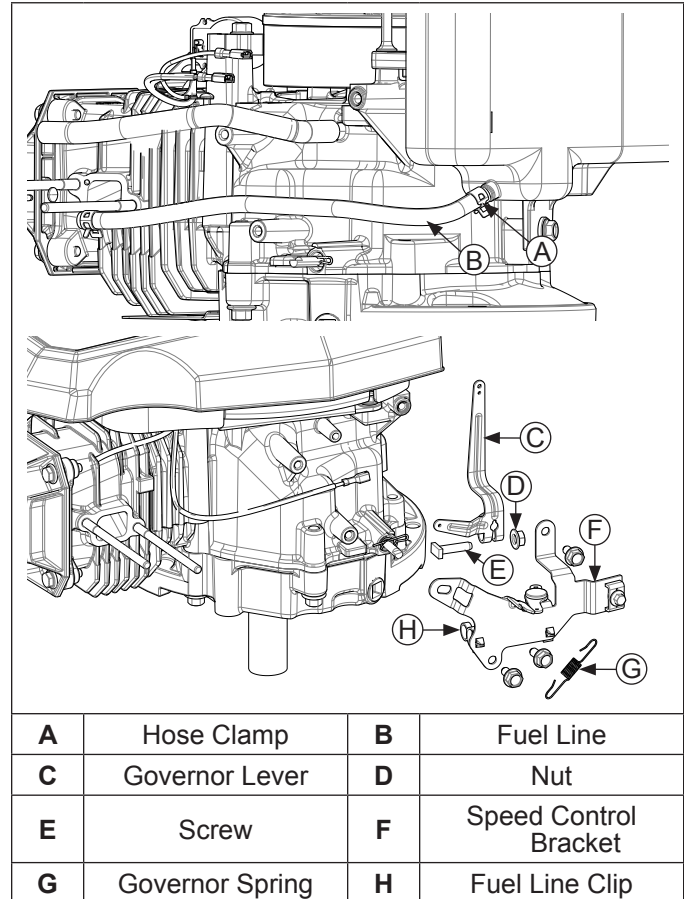

NOTE: Fuel line connecting carburetor and fuel tank is held in place by plastic fuel line clips, mounted on back of speed control bracket. If bracket is removed from crankcase, it will remain attached to fuel hose. Should replacement of speed control bracket be required, disconnect fuel line from fuel filter or carburetor and slide bracket off hose. Do not disconnect fuel hose from fuel tank.

1. Squeeze hose clamp and slide it up on fuel line (away from fuel tank).
2. Using Hose Removal Tool (see Tools and Aids) carefully remove fuel line from fuel tank. In-nipple fuel filter can stay in tank outlet.
3. Disconnect governor spring from speed control bracket.
4. Remove screws securing speed control bracket to crankcase. Remove control assembly with fuel line and choke linkage.
5. Loosen governor lever nut and slide lever with linkage and spring, off governor shaft.

Remove Muffler Assembly

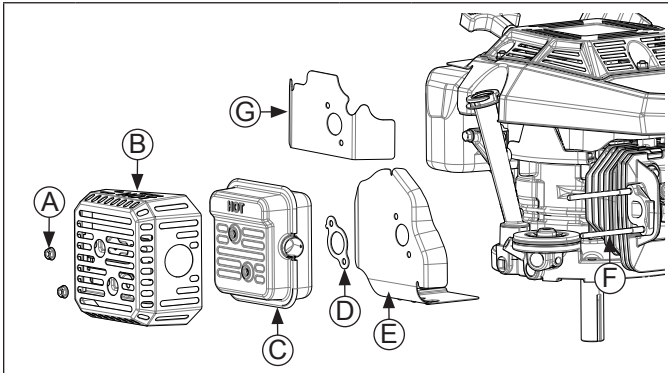

A	Nut	B	Muffler Guard
C	Muffler	D	Muffler Gasket (CV200, CV224)
E	Barrel Baffle (CV200, CV224)	F	Exhaust Stud
G	Muffler Gasket (CV173)		

1. Remove nuts from exhaust studs and remove muffler guard.
2. Slide muffler off studs.
3. Remove muffler gasket from exhaust studs.
4. On CV200 & CV224 engines, loosen screw securing barrel baffle to cylinder and slide barrel baffle off studs.

Remove Retractable Starter

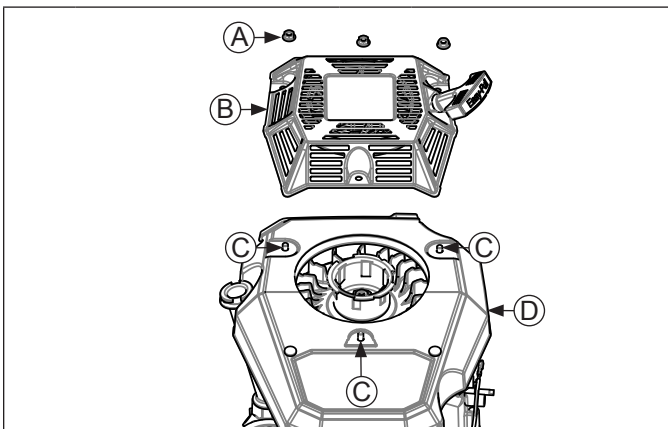

A	Nut	B	Retractable Starter
C	Stud	D	Engine Cover

Remove nuts securing retractable starter assembly to engine cover; lift starter off studs.

Remove Engine Cover and Blower Housing

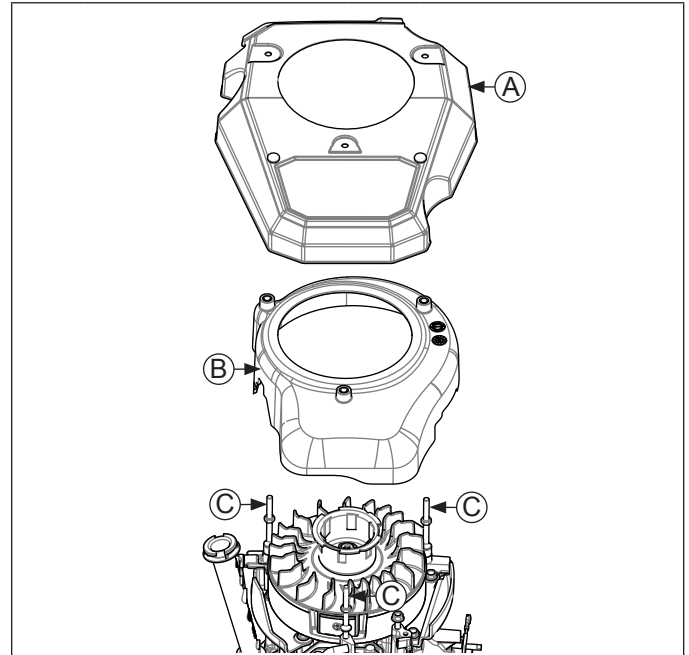

A	Engine Cover	B	Blower Housing
C	Stud		

1. Lift engine cover off studs.
2. Remove blower housing with inserts.

Remove Fuel Tank (if equipped)

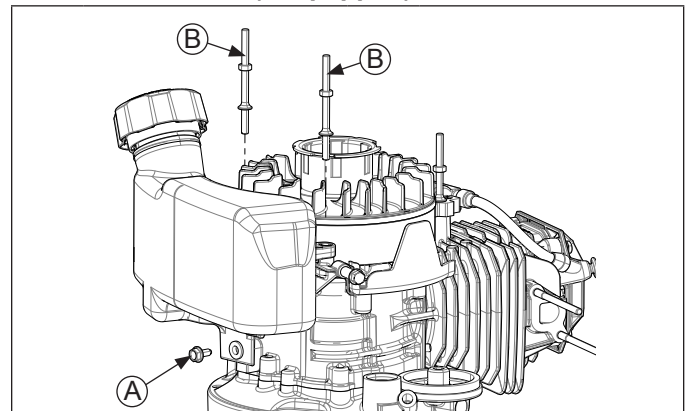

A	Screw	B	Stud
----------	-------	----------	------

1. Ensure fuel tank is empty.
2. Detach fuel tank from crankcase by removing screw.
3. Remove studs securing top of fuel tank and lift off tank.

Disassembly/Inspection and Service

Remove Ignition Module

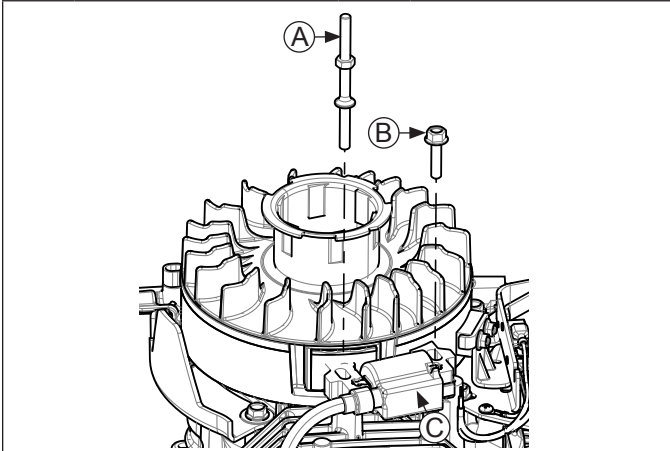

A	Stud	B	Screw
C	Ignition Module		

NOTE: Ignition kill lead can stay connected to ignition module.

Remove screw and stud securing ignition module. Mark this longer stud for identification during reassembly.

Disconnect Flywheel Brake Spring (if equipped)

Grasp 1 end of flywheel brake spring with a pliers and stretch it to disconnect it.

Remove Flywheel

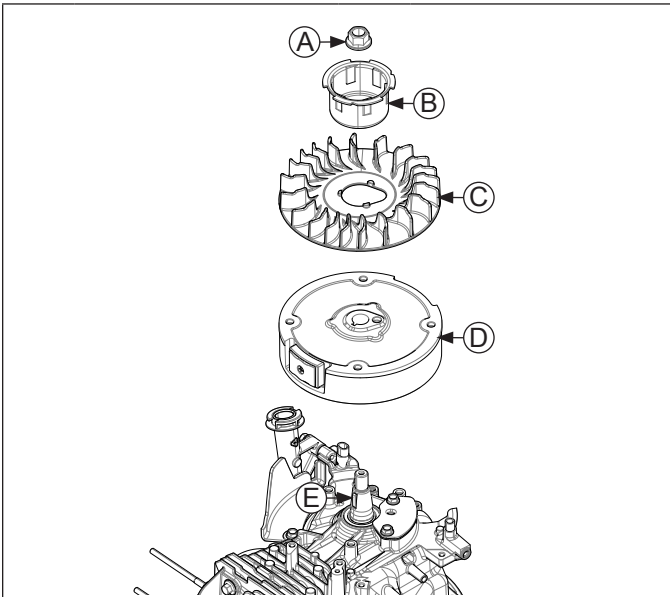

A	Flywheel Nut	B	Starter Drive Cup
C	Flywheel Fan	D	Flywheel
E	Flywheel Key		

1. Using a flywheel strap wrench to hold flywheel, remove nut inside drive cup.
2. Remove drive cup and lift off fan, noting orientation on flywheel for reassembly.

3. Flywheel is mounted on a tapered shaft. To break it loose, use a rubber mallet to land a firm blow toward outer rim of flywheel. Remove flywheel.
4. Remove flywheel key from crankshaft.

Inspection

Inspect flywheel for cracks and check keyway for wear or damage. Replace flywheel if cracked. If flywheel key is sheared or keyway is damaged, replace crankshaft, flywheel, and key.

Remove Finger Guards (as equipped)

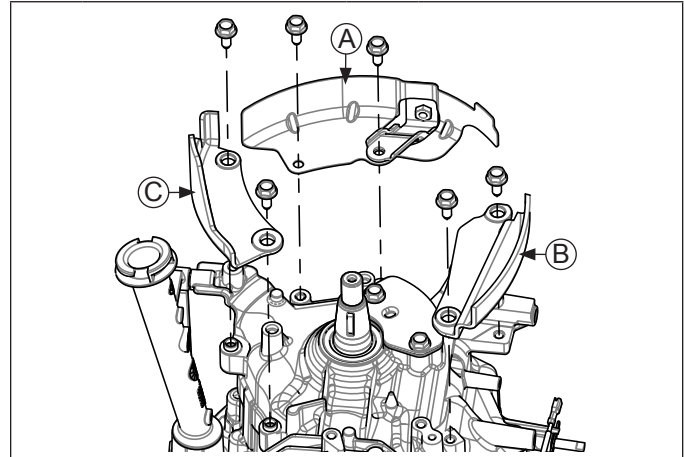

A	Rear Finger Guard	B	Finger Guard (Carburetor Side)
C	Finger Guard (Muffler Side)		

Remove screws and finger guards from crankcase.

Remove Breather Assembly

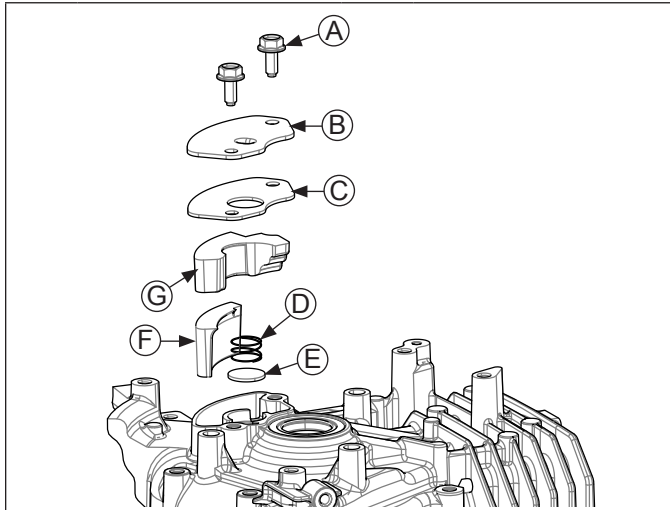

A	Screw	B	Breather Cover
C	Breather Cover Gasket	D	Breather Cover Spring
E	Disc (Breather Reed)	F	Lower Breather Media
G	Upper Breather Media		

Breather system is designed to control amount of oil in head area and still maintain necessary vacuum in crankcase.

When piston moves downward, crankcase gases are pushed past reed through mesh filter into intake system. Upward travel of piston closes reed and creates a low vacuum in lower crankcase. Any oil separated out through filter drains back into crankcase.

1. Remove screws securing breather cover. Remove cover.
2. Remove cover gasket; discard.
3. Remove breather cover spring, disc (breather reed), then upper and lower breather media.

Remove Spark Plug

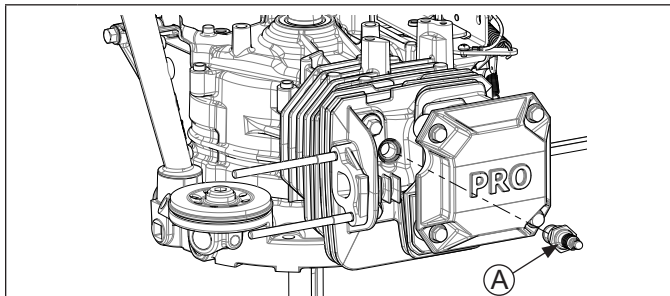

A	Spark Plug
----------	------------

Remove spark plug from cylinder head.

Remove Flywheel Brake Assembly (if equipped)

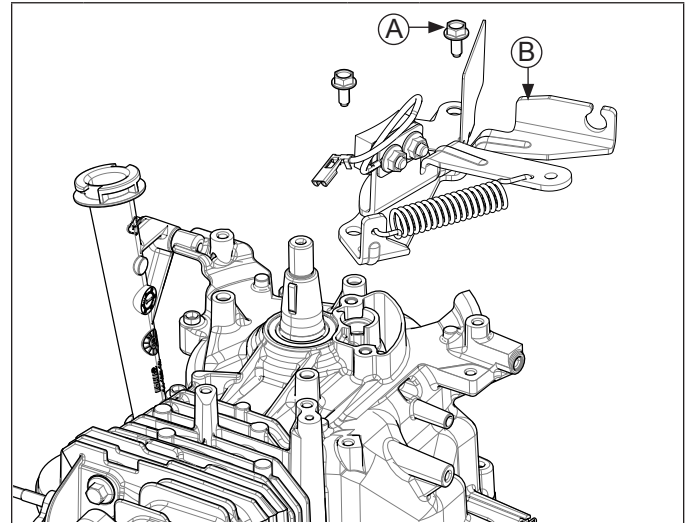

A	Screw	B	Flywheel Brake Assembly
----------	-------	----------	-------------------------

Remove screws and flywheel brake assembly from crankcase.

Remove Valve Cover

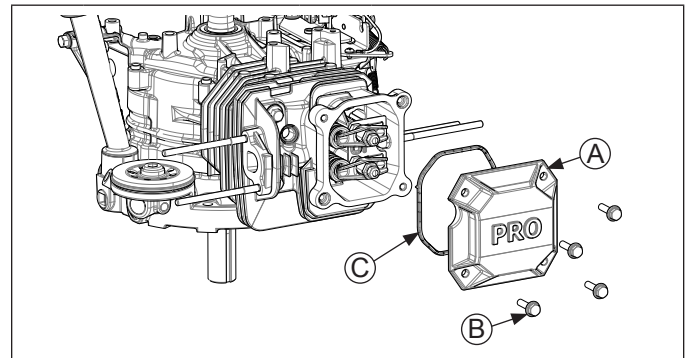

A	Valve Cover	B	Screw
C	Valve Cover Seal		

1. Remove screws from valve cover.
2. Remove cover and seal.

Disassembly/Inspection and Service

Check Guide Plate and Push Rods

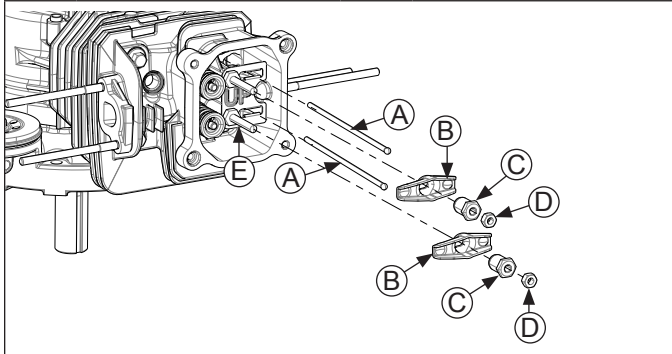

A	Push Rod	B	Rocker Arm
C	Rocker Arm Pivot	D	Jam Nut
E	Rocker Arm Stud		

NOTE: Unless guide plate is damaged, disassembly from cylinder head is unnecessary.

1. Use a socket and wrench to remove jam nuts and rocker arm pivots from rocker studs.
2. Noting orientation, lift rocker arms off rocker studs.
3. Remove push rods and mark them for reinstallation.
4. Visually inspect guide plate and replace if worn or damaged.

Remove Rocker Studs and Guide Plate

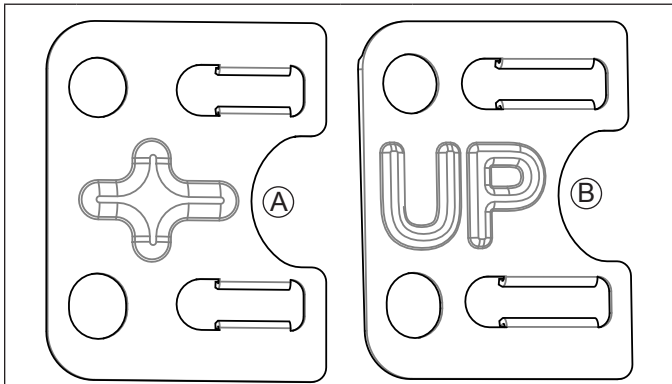

A	CV173 Guide Plate	B	CV200, CV224 Guide Plate
----------	-------------------	----------	--------------------------

1. Note orientation of guide plate (tabs down) for use during reassembly.
2. Unscrew and remove rocker studs and guide plate from cylinder head.

Remove Cylinder Head

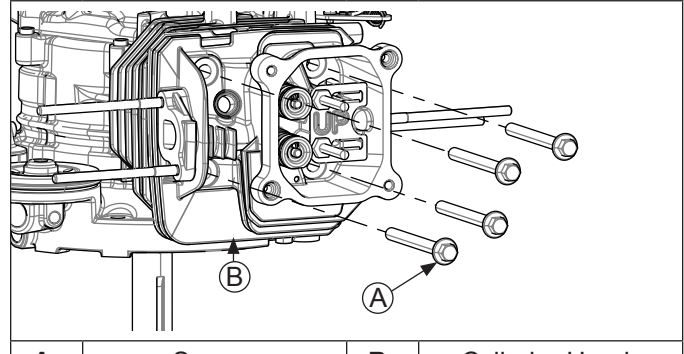

A	Screw	B	Cylinder Head
----------	-------	----------	---------------

1. Remove screws securing cylinder head. Discard screws once removed. Do not reuse.
2. Remove cylinder head, note positioning of dowels.
3. Remove head gasket and discard.

Remove Valve Assembly

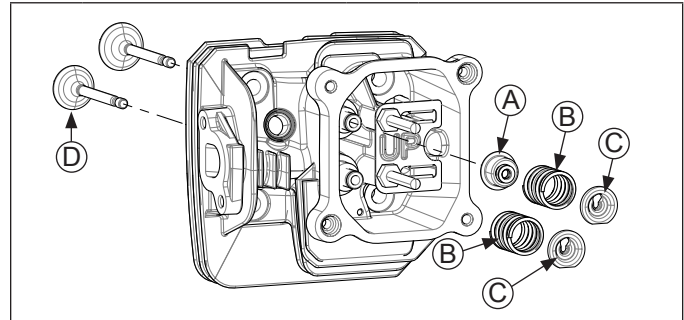

A	Intake Valve Seal	B	Spring
C	Valve Spring Retainer	D	Valve

NOTE: Only intake valve has a seal. There is no valve seal on exhaust side.

1. Push down on valve spring retainers to release valve springs from valve stems.
2. Remove valve spring retainers and springs.
3. Push end of intake valve to release valve seal.
4. Remove both valves from opposite side of head.

Inspection and Service Valve Details

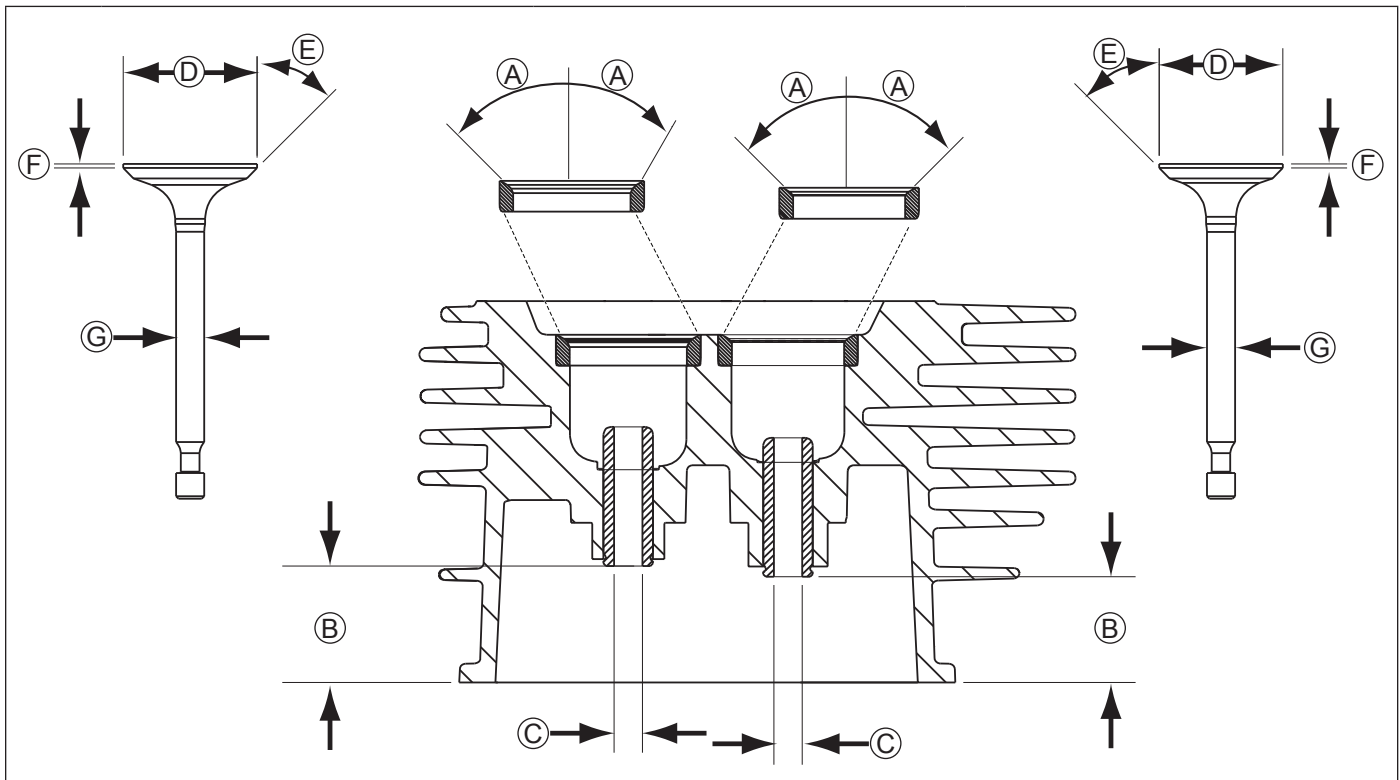

Dimension		Intake	Exhaust
A	Seat Angle	44.5°	44.5°
B	Guide Depth	22.6 mm	20.5 mm
C	Guide I.D.	5.500/5.512 mm	5.500/5.512 mm
D	Valve Head Diameter	25.875/26.125 mm	23.875/24.125 mm
E	Valve Face Angle	45°	45°
F	Valve Margin (Min.)	0.80 mm	0.80 mm
G	Valve Stem Diameter	5.465/5.480 mm	5.465/5.480 mm

After cleaning, check flatness of cylinder head and corresponding top surface of crankcase, using a surface plate or precision straight edge and feeler gauge. Maximum allowable out of flatness is 0.08 mm (0.003 in.).

Carefully inspect valve mechanism parts. Inspect valve springs and related hardware for excessive wear or distortion. Check valves and valve seats for evidence of deep pitting, cracks, or distortion.

Check running clearance between valve stems and guides.

Hard starting, or loss of power accompanied by high fuel consumption, may be symptoms of faulty valves. Although these symptoms could also be attributed to worn rings, remove and check valves first. After removal, clean valve heads, faces, and stems with a power wire brush. Then, carefully inspect each valve for defects such as warped head, excessive corrosion, or worn stem end. Replace valves found to be in bad condition.

Valve Guides

If a valve guide is worn beyond specifications, it will not guide valve in a straight line. This may result in burned valve faces or seats, loss of compression, and excessive oil consumption.

To check valve guide-to-valve stem clearance, thoroughly clean valve guide and, using a split-ball gauge, measure inside diameter. Then, using an outside micrometer, measure diameter of valve stem at several points on stem where it moves in valve guide. Use largest stem diameter to calculate clearance. If intake clearance exceeds 0.047 mm (0.0018 in.) or exhaust clearance exceeds 0.082 mm (0.0032 in.), determine whether valve stem or guide is responsible for excessive clearance.

Maximum (I.D.) wear on intake valve guide is 5.512 mm (0.2170 in.), while 5.512 mm (0.2170 in.) is maximum allowed on exhaust guide. Guides are not removable. If guides are within limits but valve stems are worn beyond limits, replace valves.

Disassembly/Inspection and Service

Valve Seat Inserts

Hardened steel alloy intake and exhaust valve seat inserts are press fitted into cylinder head. Inserts are not replaceable, but they can be reconditioned if not too badly pitted or distorted. If seats are cracked or badly warped, cylinder head should be replaced.

Recondition valve seat inserts following instructions provided with valve seat cutter being used. Final cut should be made with a 45° cutter as specified for valve seat angle. With proper 45° valve face angle, and valve seat cut properly (44.5° as measured from center line when cut 90°) this would result in desired 0.5° (1.0° full cut) interference angle where maximum pressure occurs on valve face and seat.

Lapping Valves

Reground or new valves must be lapped in, to provide a good seal. Use a hand valve grinder with suction cup for final lapping. Lightly coat valve face with fine grade of grinding compound, then rotate valve on seat with grinder. Continue grinding until smooth surface is obtained on seat and on valve face. Thoroughly clean cylinder head in soap and hot water to remove all traces of grinding compound. After drying cylinder head, apply a light coating of engine oil to prevent rusting.

Intake Valve Stem Seal

Always use a new seal when valves are removed from cylinder head. Seals should also be replaced if deteriorated or damaged in any way. Never reuse an old seal.

Remove Dipstick Tube

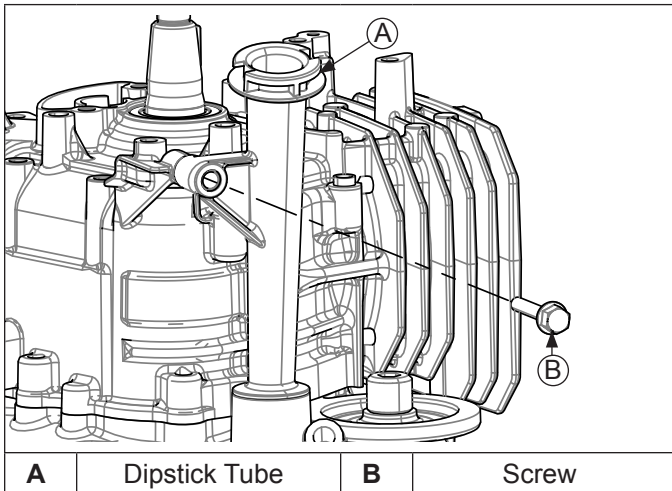

Remove screw securing dipstick tube to crankcase; remove tube.

Remove Oil Pan Assembly

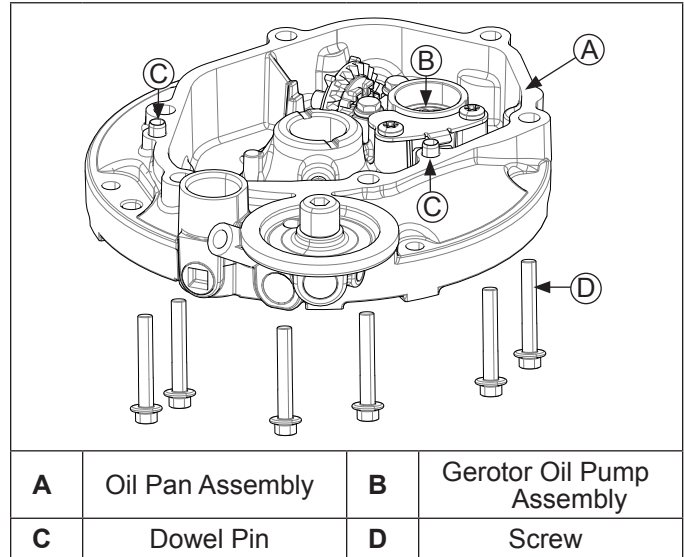

NOTE: Oil pan is sealed to crankcase using RTV silicone sealant. When removing oil pan, use care to not damage sealing surface of crankcase.

1. Remove screws securing oil pan to crankcase.
2. Using a flat blade screwdriver as a wedge, carefully separate oil pan from crankcase. Note location of gerotor oil pump assembly is when oil pan is removed. Because engine is inverted to remove pan, gerotors may be on camshaft or in oil pan.

Inspection

Inspect oil seal in oil pan and remove it if it is worn or damaged. Refer to Install Oil Pan Oil Seal in Reassembly for new oil seal installation.

Disassemble Oil Pan Assembly

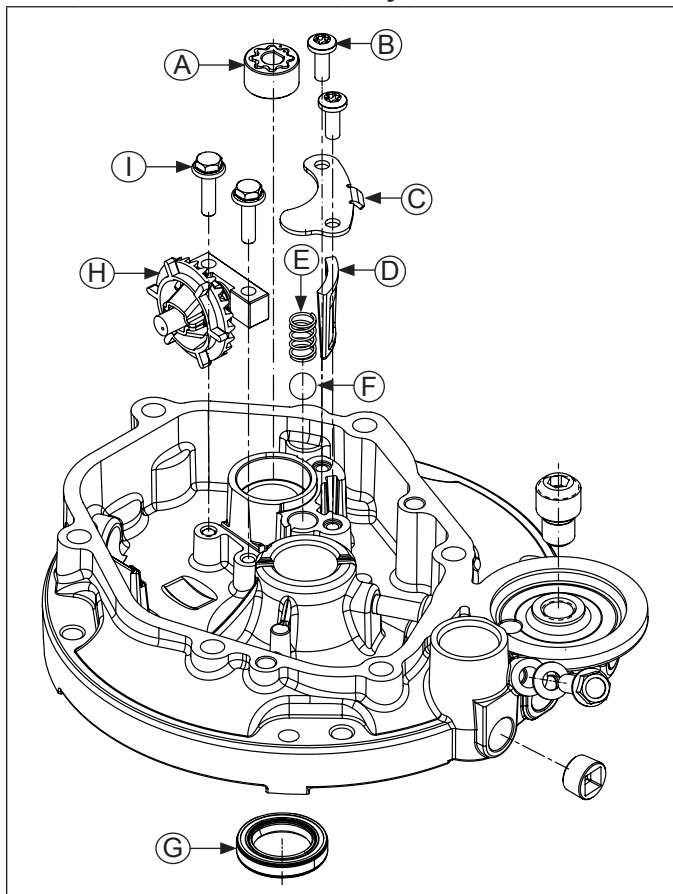

A	Gerotor Oil Pump Assembly	B	Screw
C	Oil Pump Screen Cover	D	Oil Screen
E	Spring	F	Ball
G	Oil Pan Oil Seal	H	Governor Gear Assembly
I	Screw		

Governor Gear Assembly

Governor gear assembly is located inside oil pan assembly. If service is required, refer to Inspection, Disassembly, and Reassembly procedures.

Inspection

Inspect governor gear teeth for wear, chips, or missing teeth. Inspect governor weights. They should move freely in governor gear.

Disassembly

Remove screws and lift governor gear assembly from oil pan.

Reassembly

Position governor gear assembly in oil pan and secure with screws. Torque screws to 9.5 N·m (84 in. lb.).

Oil Pump

Oil pump is located inside of oil pan. If service is required, continue with Disassembly, Inspection, and Reassembly.

Disassembly

1. Remove screws and oil pump screen cover.
2. Remove spring and ball from pressure relief hole of oil pan.
3. Lift oil screen from oil pan.

Inspection

Inspect oil pump bore and gerotors for nicks, burrs, wear, or any visible damage. Inspect ball and spring for any visible damage. Check oil screen for damage or restriction, replace as necessary.

Reassembly

1. Install oil screen in oil pan.
2. Install ball then spring into pressure relief hole of oil pan.
3. Install oil pump screen cover and hold to compress spring. Secure cover with screws. Torque screws to 9.5 N·m (84 in. lb.).

Gerotor oil pump assembly will be installed after camshaft is installed. Refer to Install Camshaft in Reassembly.

Disassembly/Inspection and Service

Crankcase Components

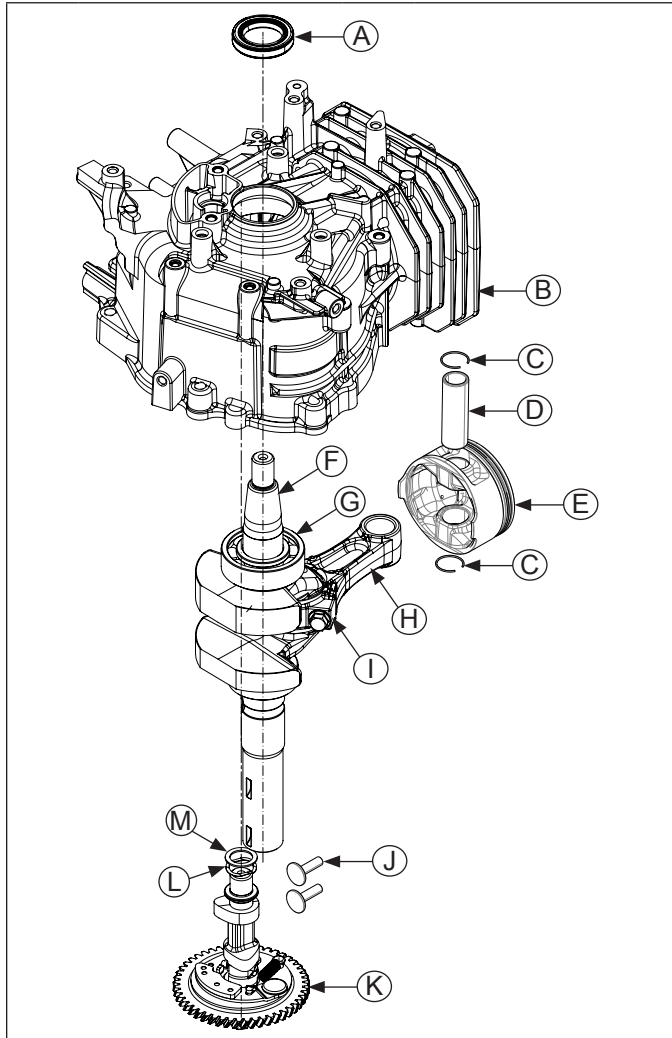

A	Crankcase Oil Seal	B	Crankcase
C	Piston Pin Retainer	D	Piston Pin
E	Piston	F	Crankshaft
G	Crankcase Bearing	H	Connecting Rod
I	Connecting Rod End Cap	J	Valve Lifters
K	Camshaft	L	Wave Spring
M	Camshaft Washer		

Remove Camshaft

Remove camshaft with wave spring and camshaft washer from crankcase.

Inspection and Service

Inspect gear teeth of camshaft. If teeth are badly worn or chipped, or if some are missing, replacement of camshaft will be necessary. If unusual wear or damage is evident on either camshaft lobes or mating valve lifters camshaft and both valve lifters must be replaced. Check condition and operation of Automatic Compression Release (ACR) mechanism.

ACR

These engines are equipped with an ACR mechanism. ACR lowers compression at cranking speeds to make starting easier.

ACR mechanism consists of a decompression weight and arm mounted to camshaft, and activated by a return spring. When engine is rotating at low cranking speeds (1000 RPM or less), decompression weight holds arm so it protrudes above heel of exhaust lobe. This holds exhaust valve off its seat during first part of compression stroke.

After engine speed increases above approximately 1000 RPM, centrifugal force causes decompression weight to move outward, causing arm to retract. When in this position, arm has no effect on exhaust valve and engine operates at FULL compression and power.

Benefits

As a result of reduced compression at cranking speeds, several important benefits are obtained:

1. Manual (retractable) starting is much easier. Without ACR, manual starting would be virtually impossible.
2. ACR eliminates need for a spark retard/advance mechanism. A spark retard/advance mechanism would be required on engines without ACR to prevent kickback which would occur during starting. ACR eliminates this kickback, making manual starting safer.
3. Choke control setting is less critical with ACR. If flooding occurs, excess fuel is blown out opened exhaust valve and does not hamper starting.
4. Engines with ACR start much faster in cold weather than engines without ACR.
5. Engines with ACR can be started with spark plugs which are worn or fouled. Engines without ACR are more difficult to start with those same spark plugs.

Remove Valve Lifters

Remove valve lifters. Mark them INTAKE and EXHAUST for reinstallation.

Remove Connecting Rod Cap

Rotate crankshaft to allow access to 2 screws on connecting rod cap. Remove screws and cap. Note position of match marks (to oil pan side).

Remove Piston and Connecting Rod

Carefully guide piston and attached connecting rod out of cylinder bore.

Connecting Rod Inspection and Service

Check bearing area (big end) for excessive wear, score marks, running and side clearances. Replace connecting rod and end cap if scored or excessively worn.

Service replacement connecting rods are available in STD size.

Piston and Rings Inspection

Scuffing and scoring of pistons and cylinder walls occurs when internal engine temperatures approach welding point of piston. Temperatures high enough to do this are created by friction, which is usually attributed to improper lubrication and/or overheating of engine.

Normally, very little wear takes place in piston boss or piston pin area. If original piston and connecting rod can be reused after new rings are installed, original pin can also be reused but new piston pin retainers are required. Piston pin is included as part of piston assembly – if pin boss in piston or pin itself is worn or damaged, a new piston assembly is required.

Ring failure is usually indicated by excessive oil consumption and blue exhaust smoke. When rings fail, oil is allowed to enter combustion chamber where it is burned along with fuel. High oil consumption can also occur when piston ring end gap is incorrect, because ring cannot properly conform to cylinder wall under this condition. Oil control is also lost when ring gaps are not staggered during installation.

When cylinder temperatures get too high, lacquer and varnish collect on pistons, causing rings to stick, which results in rapid wear. A worn ring usually takes on a shiny or bright appearance.

Scratches on rings and pistons are caused by abrasive material such as carbon, dirt, or pieces of hard metal.

Detonation damage occurs when a portion of fuel charge ignites spontaneously from heat and pressure shortly after ignition. This creates two flame fronts, which meet and explode to create extreme hammering pressures on a specific area of piston. Detonation generally occurs from using low octane fuels.

Preignition or ignition of fuel charge before timed spark can cause damage similar to detonation. Preignition damage is often more severe than detonation damage. Preignition is caused by a hot spot in combustion chamber such as glowing carbon deposits, blocked cooling fins, an improperly seated valve, or a wrong spark plug.

Replacement pistons are available in STD bore size. Replacement pistons include new piston ring sets and new piston pins.

Replacement ring sets are also available separately for STD pistons. Always use new piston rings when installing pistons. Never use old rings.

Some important points to remember when servicing piston rings:

1. Cylinder bore must be de-glazed before service ring sets are used.
2. If cylinder bore does not need re-boring and if old piston is within wear limits and free of score or scuff marks, old piston may be reused.
3. Remove old rings and clean up grooves. Never reuse old rings.
4. Before installing new rings on piston, place top 2 rings, each in turn, in its running area in cylinder bore and check end gap. Compare ring gap to Clearance Specifications.
5. After installing new compression (top and middle) rings on piston, check piston-to-ring side clearance. Compare clearance to Clearance Specifications. If side clearance is greater than specified, a new piston must be used.

Install New Piston Rings

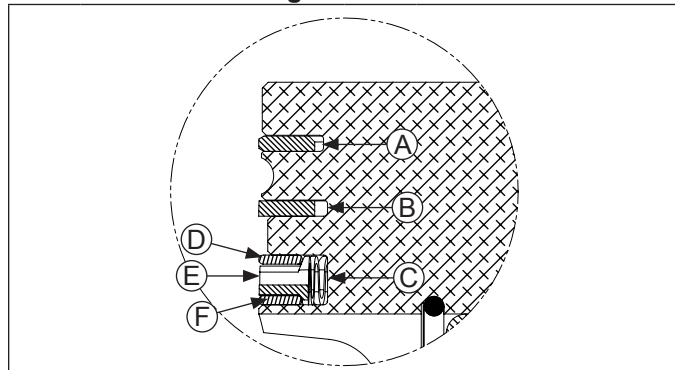

A	Top Compression Ring	B	Middle Compression Ring
C	Oil Control Ring	D	Top Rail
E	Expander Ring	F	Bottom Rail

Piston Ring Orientation

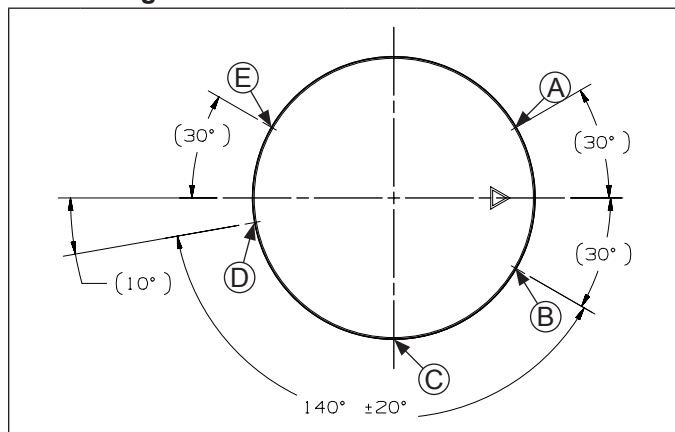

A	Top Oil Rail Gap	B	Top Compression Ring Gap
C	Oil Ring Expander Gap	D	Middle Compression Ring Gap
E	Bottom Oil Rail Gap		

NOTE: Rings must be installed correctly. Install oil control ring assembly (bottom groove) first, middle compression ring (center groove) second, and top compression ring (top groove) last. Oil control ring assembly is a three-piece design, and consists of a top rail, expander ring, and bottom rail.

Use a piston ring expander to install rings.

1. Oil control ring assembly (bottom groove): Install expander first then bottom rail and top rail last. Make sure ends of expander are not overlapped. Adjust ring gaps.
2. Middle compression ring (center groove): Install middle compression ring using a piston ring expander tool. Make sure identification mark is up or colored dye stripe (if contained) is left of end gap. Adjust ring gaps.

Disassembly/Inspection and Service

- Top compression ring (top groove): Install top compression ring using a piston ring expander tool. Make sure identification mark is up or colored dye stripe (if contained) is left of end gap. Adjust ring gaps.

Remove Crankshaft

Remove crankshaft and thrust washer.

Inspection and Service

Inspect gear teeth of crankshaft and cam gear. If any teeth are badly worn or chipped, or if some are missing, replacement of crankshaft will be necessary.

Inspect crankshaft bearing surfaces for scoring, grooving, etc. Measure running clearance between crankshaft journals and their respective bearing bores. Use an inside micrometer or telescoping gauge to measure inside diameter of both bearing bores in vertical and horizontal planes. Use an outside micrometer to measure outside diameter of crankshaft main bearing journals. Subtract journal diameters from their respective bore diameters to get running clearances. Check results against values in Specifications and Tolerances. If running clearances are within specification, and there is no evidence of scoring, grooving, etc., no further reconditioning is necessary. If bearing surfaces are worn or damaged, crankcase and/or closure plate will need to be replaced.

Inspect crankshaft keyway. If worn or chipped, replacement of crankshaft will be necessary.

Inspect crankpin for score marks or metallic pickup. Slight score marks can be cleaned with crocus cloth soaked in oil. If wear limits in Specifications are exceeded, it will be necessary to replace crankshaft.

Remove Governor Cross Shaft

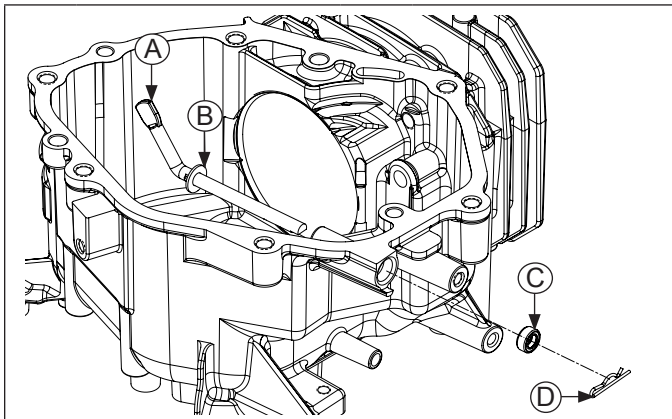

A	Governor Cross Shaft	B	Flat Washer
C	Oil Seal	D	Governor Shaft Clip

Remove clip securing governor shaft. Remove shaft and washer.

Inspection

Inspect oil seal in crankcase and remove it if it is worn or damaged. Refer to Install Governor Cross Shaft Oil Seal in Reassembly for new oil seal installation.

Crankcase

Inspection and Service

Check all gasket surfaces to make sure they are free of gasket fragments and deep scratches or nicks.

Check cylinder wall for scoring. In severe cases, unburned fuel can dissolve lubricating oil off piston and cylinder wall. Without lubrication, piston rings would make metal to metal contact with wall, causing scuffing and scoring. Scoring of cylinder wall can also be caused by localized hot spots from blocked cooling fins or from inadequate or contaminated lubrication.

NOTE: Make sure engine is assembled using all specified torque values, tightening sequences, and clearances. Failure to observe specifications could cause severe engine wear or damage.

NOTE: Always use new gaskets.

NOTE: Make sure all components have been properly cleaned BEFORE reassembly.

NOTE: Remove all traces of cleaners before engine is reassembled and placed into operation. Even small amounts of these cleaners can quickly break down lubricating properties of engine oil.

Install Crankcase Oil Seal

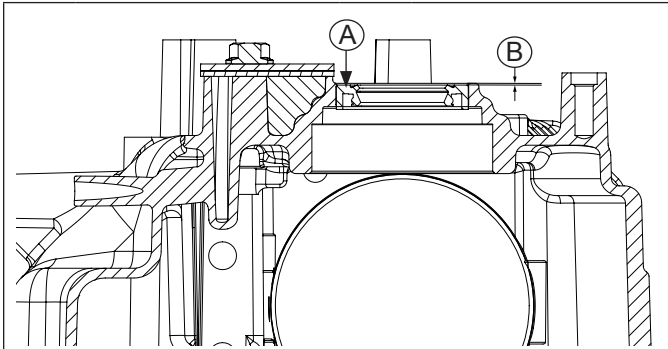

A	Oil Seal	B	0.5 mm (0.0197 in.)
----------	----------	----------	---------------------

1. Make sure seal bore of crankcase is clean and free of any nicks or burrs.
2. Apply a light coat of clean engine oil to outside diameter of oil seal.
3. Drive oil seal into crankcase using a seal driver. Make sure oil seal is installed straight and true in bore to depth shown.

Install Governor Cross Shaft Oil Seal

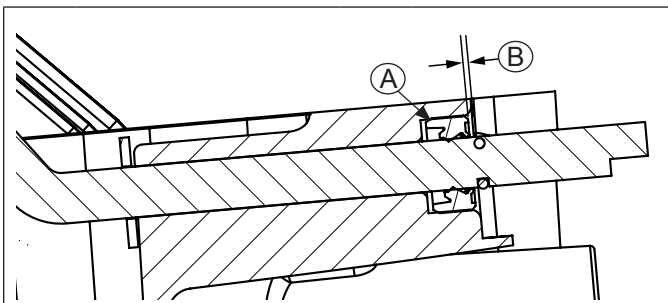

A	Oil Seal	B	0.5 mm (0.0197 in.)
----------	----------	----------	---------------------

1. Make sure seal bore of crankcase is clean and free of any nicks or burrs.
2. Apply a light coat of clean engine oil to outside diameter of oil seal.
3. Drive oil seal into crankcase using a seal driver. Make sure oil seal is installed straight and true in bore to depth shown.

Install Governor Cross Shaft

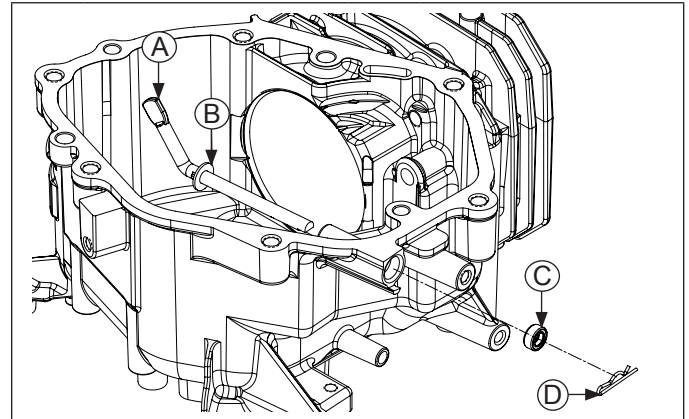

A	Governor Cross Shaft	B	Flat Washer
C	Oil Seal	D	Governor Shaft Clip

1. Lubricate governor cross shaft with engine oil.
2. Slide flat washer on governor cross shaft and install cross shaft from inside of crankcase.
3. Secure cross shaft with clip.

Reassembly

Crankcase Components

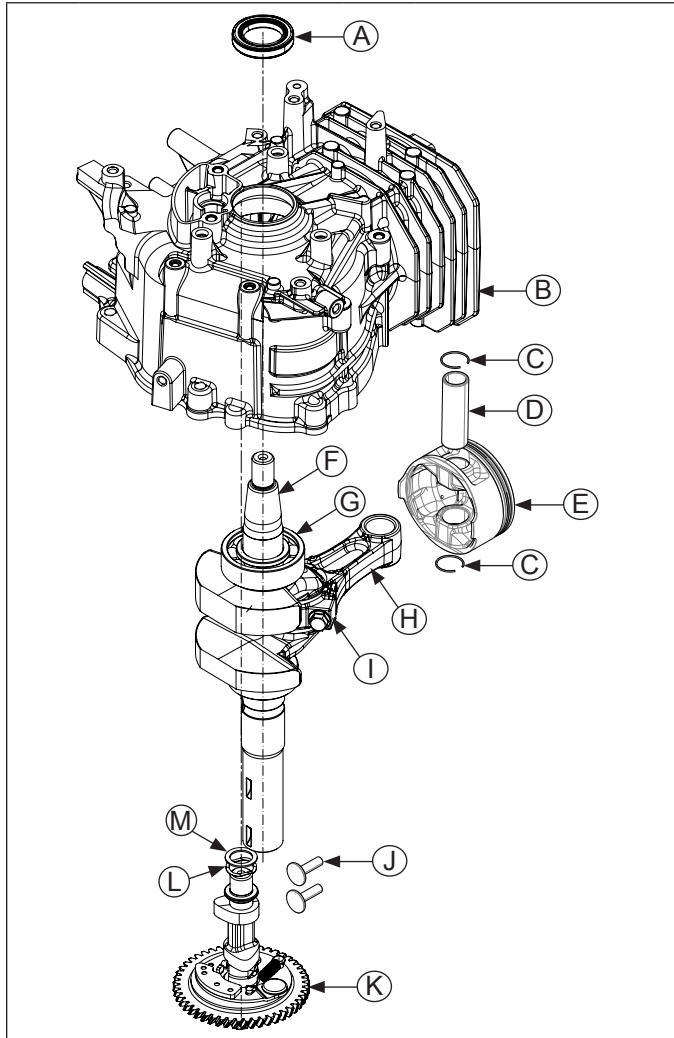

A	Crankcase Oil Seal	B	Crankcase
C	Piston Pin Retainer	D	Piston Pin
E	Piston with Rings	F	Crankshaft
G	Crankcase Bearing	H	Connecting Rod
I	Connecting Rod End Cap	J	Valve Lifters
K	Camshaft	L	Wave Spring
M	Camshaft Washer		

Install Crankshaft

Carefully install crankshaft into crankcase through front seal, and fully seat into place. Rotate crankshaft until journal for connecting rod is away from cylinder.

Install Piston and Connecting Rod

NOTE: Proper orientation of piston and connecting rod inside engine is extremely important. Improper orientation can cause extensive wear or damage.

1. If piston rings were removed, see Disassembly/Inspection and Service procedure to install rings.
2. Compress piston rings using a piston ring compressor.
3. Position triangle on top of piston toward push rod chamber.
4. Carefully guide connecting rod, with piston attached, into bore.
5. Use handle of a soft, rubber-grip hammer to tap piston into bore.
6. Rotate crankshaft to mate with connecting rod. Align rod cap and connecting rod to match marks. Torque screws to 12.5 N·m (111 in. lb.).

Install Valve Lifters

Apply camshaft lubricant to contact surfaces of valve lifters. Install intake and exhaust valve lifters into their respective positions, as previously marked. A small amount of grease applied to stems will hold valve lifters up until camshaft is installed.

Install Camshaft

1. Liberally apply camshaft lubricant to lobes of camshaft and cam gear surfaces. Lubricate camshaft bearing surfaces of crankcase and camshaft with engine oil.
2. Install wave washer, then flat washer on camshaft.
3. Install camshaft into crankcase and align timing marks.
4. Install gerotor oil pump assembly (inner and outer rotors) onto camshaft with dots facing cam.

Governor Gear Assembly

Governor gear assembly is located inside oil pan. If service was required, and governor was removed, refer to Disassembly/Inspection and Service.

Oil Pump Assembly

Oil Pump assembly is located inside oil pan. If service was required, and oil pump was removed, refer to Disassembly/Inspection and Service.

Install Oil Pan Assembly

Torque Sequence

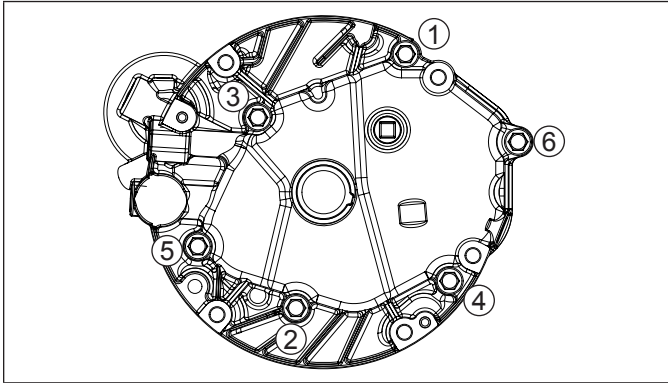

4. Apply a 1.5 mm (1/16 in) bead of Permatex® Ultra Grey® sealant to sealing surface of oil pan. See sealant pattern for engine being serviced. Oil pan must be installed within 10 minutes of RTV application.
5. Guide oil pan onto crankcase, ensuring camshaft, oil pump, and governor gear align with their mating surfaces. Rotate crankshaft slightly to help engage governor gear.
6. Install and finger tighten screws securing oil pan to crankcase.
7. Use torque sequence shown and torque oil pan screws to 14.7 N·m (130 in. lb.).

CV173 Sealant Pattern

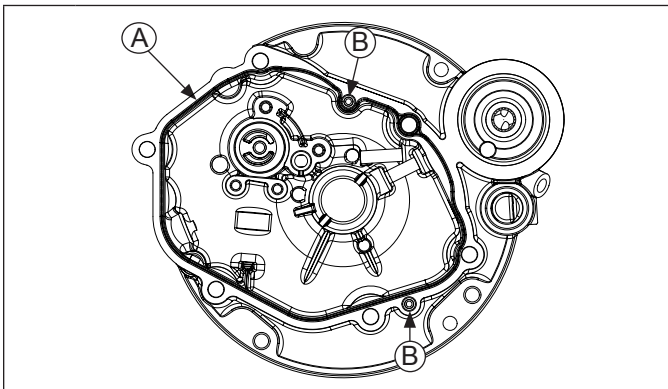

CV200, CV224 Sealant Pattern

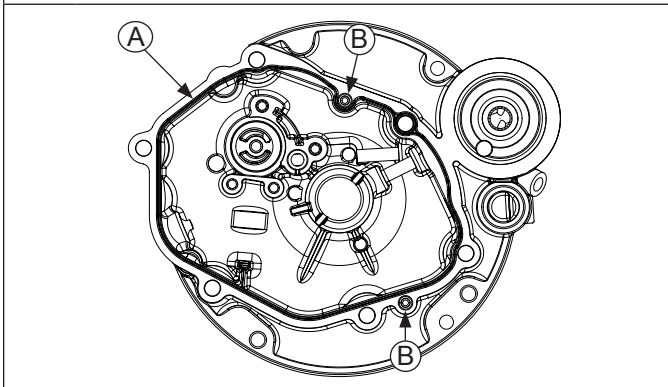

A	1.5 mm (1/16 in.) bead of sealant.
B	Dowel Pin

NOTE: When installing oil pan, ensure plunger on governor gear is pressed fully into governor. Incorrectly installing governor plunger may result in damage.

NOTE: Always use fresh sealant. Using outdated sealant can result in leakage. Use Permatex® Ultra Grey® sealant.

1. Sealing surfaces of crankcase and oil pan should be clean, dry, and free of any nicks or burrs.
2. Install 2 dowel pins into oil pan.
3. Install thrust washer on crankshaft.

Install Dipstick Tube

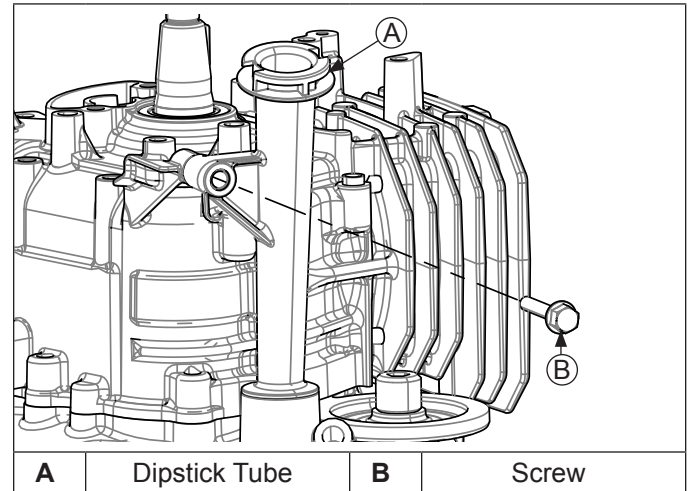

Insert dipstick tube into oil pan and secure to crankcase with screw. Torque screw to 8 N·m (71 in. lb.).

Reassembly

Cylinder Head Assembly

Prior to assembly, lubricate all components with engine oil, including tips of valve stems and valve guides.

Install Valve Train

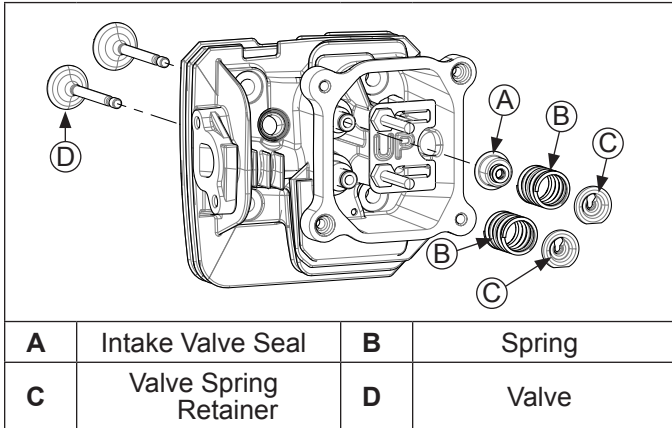

1. Install intake and exhaust valves into their respective positions in cylinder head.
2. Install intake valve seal onto intake valve. Next, slide valve springs onto both valves and lock them in place with valve spring retainers.

Install Cylinder Head

Torque Sequence

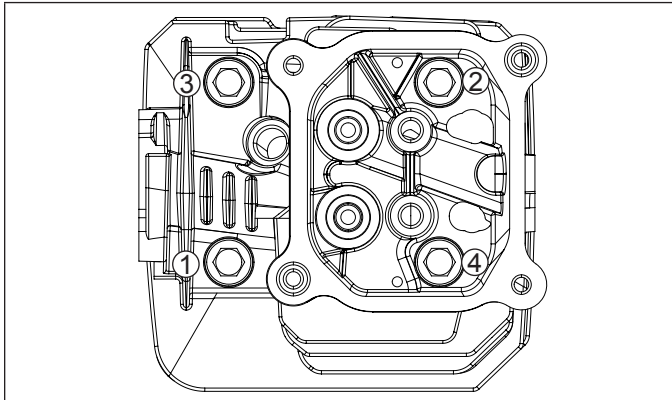

NOTE: Do not reuse cylinder head screws or gasket. Always replace with new screws or gasket.

1. Examine sealing surfaces of cylinder head and crankcase for nicks or burrs. Ensure dowel pins are in position in crankcase.
2. Using cylinder head dowels as a guide, install a new head gasket.
3. Install cylinder head and finger tighten new screws.
4. Torque screws in two stages; first to 13 N·m (115 in. lb.), finally to 25.7 N·m (227 in. lb.), following sequence shown.

Install Push Rod Assembly

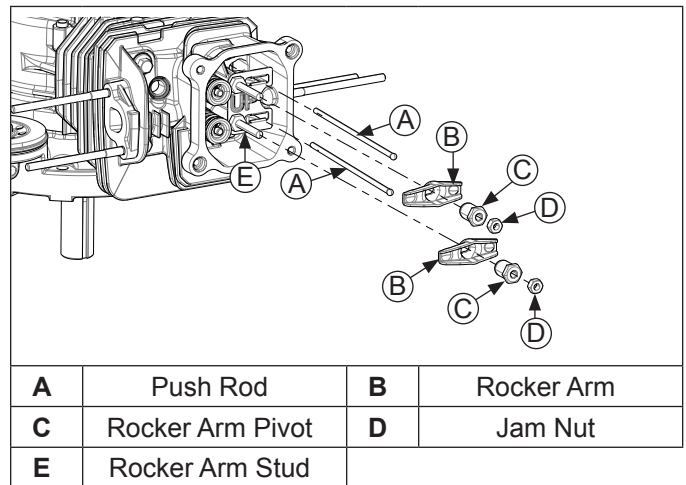
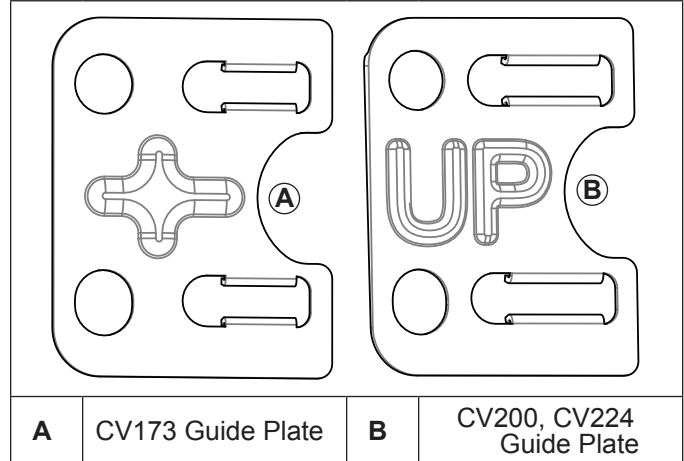

NOTE: Installation and seating of push rods into tappet recesses during this sequence is critical. To aid with proper installation of push rods and rocker arms, and for adjusting valve lash, position engine with cylinder head up. When properly installed, push rods extend approximately 1 in. (25.4 mm) above guide plate.

1. With tabs on guide plate facing down, install guide plate and secure with rocker studs.
2. Torque rocker studs to 13.6 N·m (120 in. lb.).
3. Install push rods into intake and exhaust positions, as previously marked.
4. Apply grease to contact surfaces of rocker arms and pivots.
5. Install rocker arms onto rocker studs. Match rocker arm dimples with round push rod ends.
6. Loosely install pivots and jam nuts onto rocker studs.
7. With rocker arms and push rods in their correct position, inspect push rod to guide plate clearance. Push rods need to be centered in guide plate opening. If contact is present, readjust guide plate starting in step 1.

- With piston at top dead center of compression stroke, insert a 0.1 mm (0.004 in.) flat feeler gauge between 1 valve stem and rocker arm.

Valve Clearance Specifications:

Intake Valve 0.0762-0.1270 mm (0.003-0.005 in.)
 Exhaust Valve 0.0762-0.1270 mm (0.003-0.005 in.)

- Tighten rocker pivot with a wrench until a slight drag is felt on feeler gauge. Hold nut in position and tighten jam nut to 9.5 N·m (84 in. lb.). Recheck lash. Perform same adjustment procedure on opposite valve.

Install Valve Cover

Torque Sequence

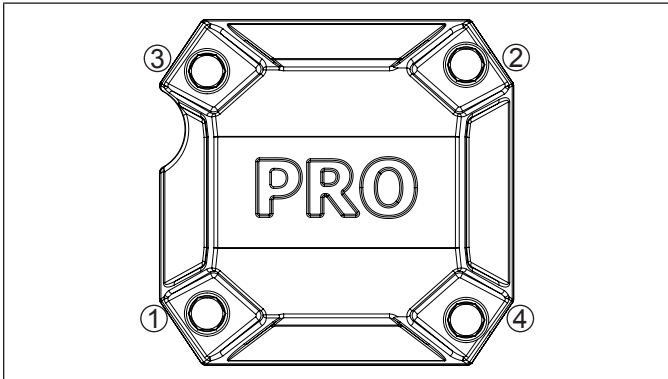

Alignment Marks

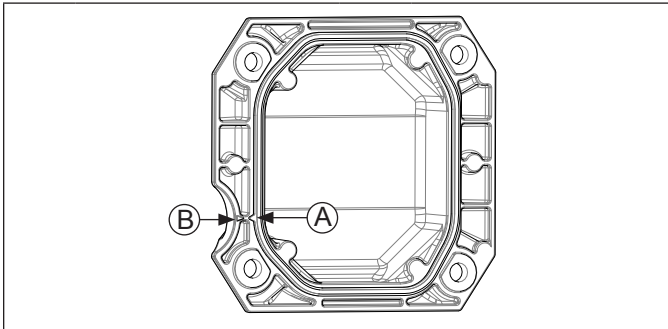

A	Seal Mark	B	Valve Cover Mark
----------	-----------	----------	------------------

- Position a new valve cover seal in valve cover. Seal mark should align to mark in valve cover as shown.
- Install valve cover with cutout by spark plug hole in cylinder head and finger tighten screws.
- Using sequence shown, torque screws to 8 N·m (71 in. lb.).

Install New Spark Plug

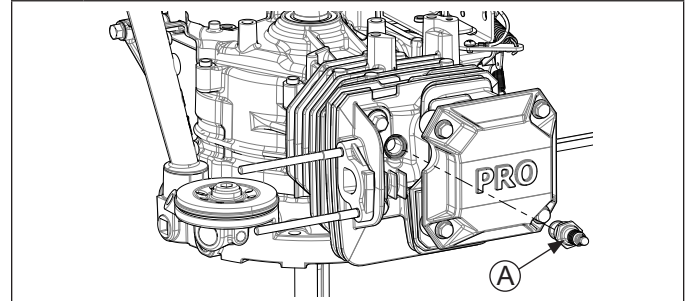

A	Spark Plug
----------	------------

- Set gap of a new spark plug to 0.76 mm (0.030 in.).
- Install spark plug and torque to 27 N·m (20 ft. lb.).

Install Flywheel Brake Assembly (if equipped)

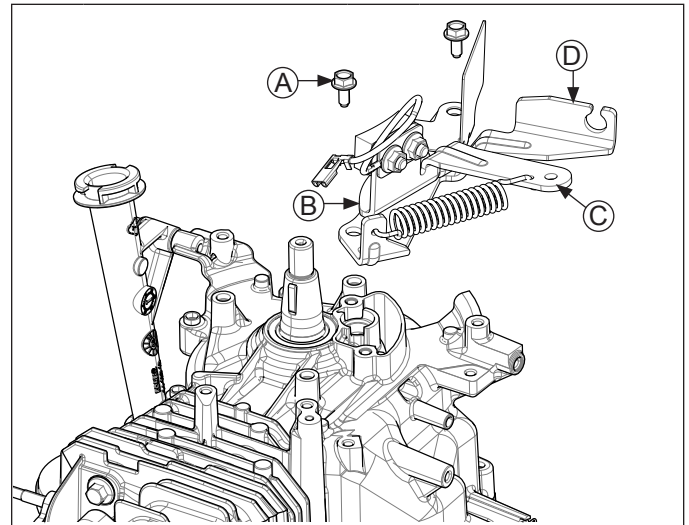

A	Screw	B	Flywheel Brake Assembly
C	Brake Lever	C	Brake Bracket

- Place brake assembly onto crankcase and loosely install screws.
- Install a caliper between brake lever and bracket to establish a 50 mm (1.968 in.) gap, pivoting on rear screw if necessary.
- Rotate brake lever clockwise around rear screw. Torque screws to 9.5 N·m (84 in. lb.).

Reassembly

Install Breather Assembly

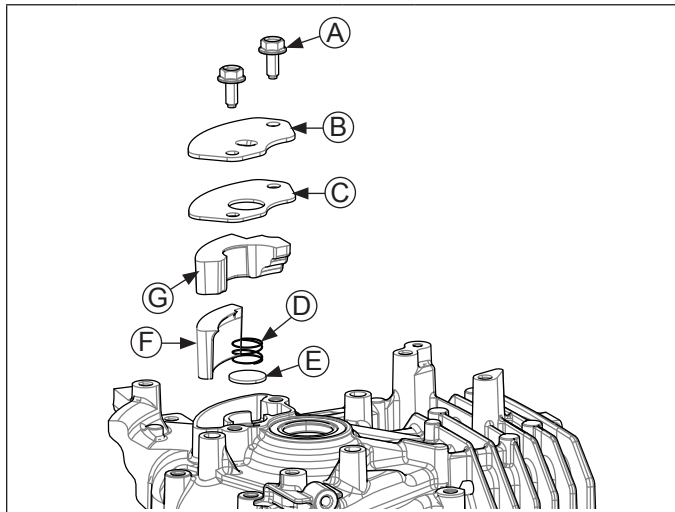

A	Screw	B	Breather Cover
C	Breather Cover Gasket	D	Breather Cover Spring
E	Disc (Breather Reed)	F	Lower Breather Media
G	Upper Breather Media		

1. Install lower breather media into cavity, then install upper breather media.
2. Install disc (breather reed) and breather cover spring.
3. Install cover gasket so spring is through hole in gasket.
4. Install breather cover with dimple down to compress spring and secure with screws. Torque screws to 10 N·m (89 in. lb.).

Install Finger Guards (as equipped)

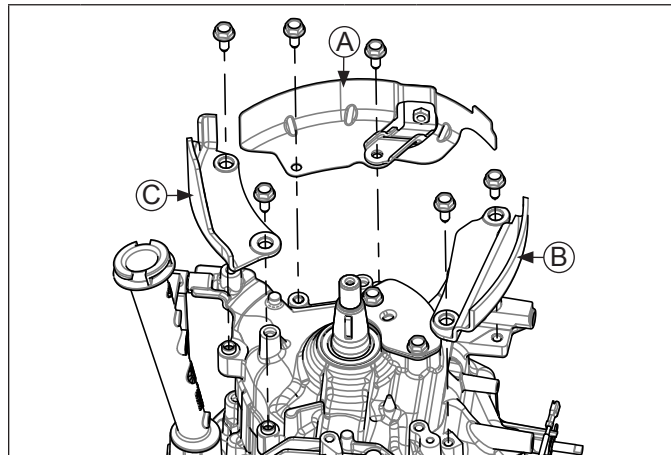

A	Rear Finger Guard	B	Finger Guard (Carburetor Side)
C	Finger Guard (Muffler Side)		

Install finger guards and secure with screws. Torque side guard screws to 9.5 N·m (84 in. lb.). Torque rear guard screws to 10 N·m (89 in. lb.).

Install Flywheel



⚠ CAUTION

Damaging Crankshaft and Flywheel can cause personal injury.

Using improper procedures can lead to broken fragments. Broken fragments could be thrown from engine. Always observe and use precautions and procedures when installing flywheel.

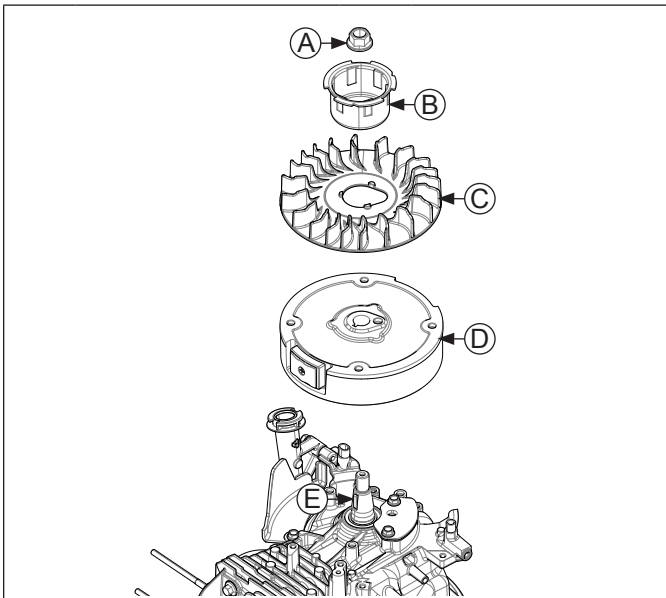

A	Flywheel Nut	B	Starter Drive Cup
C	Flywheel Fan	D	Flywheel
E	Flywheel Key		

NOTE: Before installing flywheel make sure crankshaft taper and flywheel hub are clean, dry, and completely free of lubricants. Presence of lubricants can cause flywheel to be over stressed and damaged when mounting nut is torqued to specification.

NOTE: Make sure flywheel key is installed properly in keyway. Flywheel can become cracked or damaged if key is not properly installed.

NOTE: Always use a flywheel strap wrench to hold flywheel when tightening flywheel fastener. Do not use any type of bar or wedge to prevent flywheel from rotating, as these parts could become cracked or damaged.

1. Install key into crankshaft keyway. Make sure key is fully seated.
2. Install flywheel onto crankshaft aligning keyway with key.
3. Align teardrop slot on fan with raised teardrop on flywheel. Align drive cup on flywheel, and install and hand tighten nut.

4. Use a flywheel strap wrench to hold flywheel and tighten nut. Torque nut to 51.5 N·m (38 ft. lb.).

Install Ignition Module

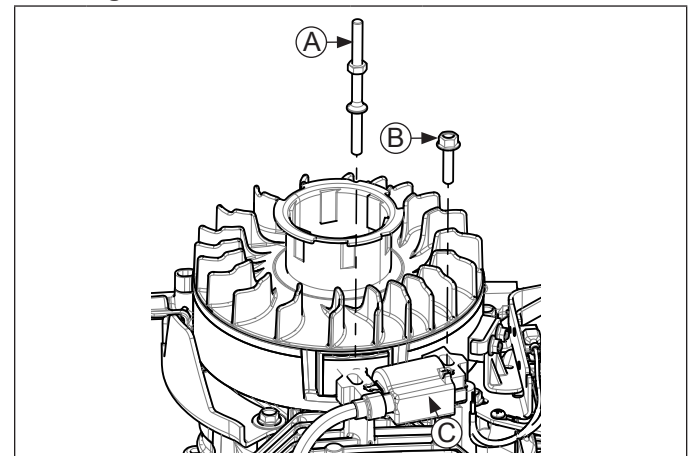

A	Stud	B	Screw
C	Ignition Module	D	Module Kill Tab

NOTE: If stud for mounting ignition module was not marked during disassembly, compare lengths of studs and choose shorter stud with longer thread area.

1. Rotate flywheel so ignition magnets are away from ignition module legs. Position ignition module on legs with kill tab down.
2. Loosely thread stud and screw (kill lead side) into appropriate leg. Pull module away from flywheel and tighten stud to hold it in place. Rotate flywheel so ignition magnet is aligned with module.
3. Set air gap by placing a 0.254 mm (0.010 in.) plastic feeler gauge between magnet and module. Loosen stud and screw to allow magnet to draw module against feeler gauge. Torque fasteners to 10 N·m (89 in. lb.).
4. Rotate flywheel to release feeler gauge, and check that module does not come in contact with magnet. Recheck air gap.
5. Connect kill lead to ignition module kill tab.

Reassembly

Install Fuel Tank (if equipped)

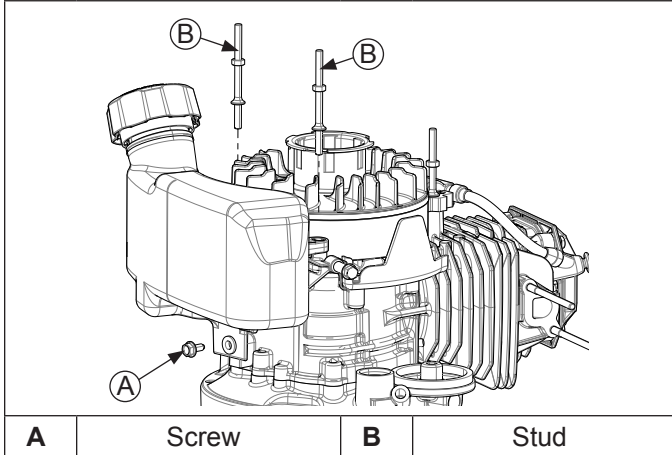

1. Secure fuel tank to crankcase with screw. Torque screw to 8 N·m (71 in. lb.).
2. Secure top of fuel tank to crankcase by installing threaded studs. Torque studs to 10 N·m (89 in. lb.).

Connect Flywheel Brake Spring (if equipped)

Using a pliers, attach flywheel brake spring onto bracket hook.

Install Governor Lever Assembly

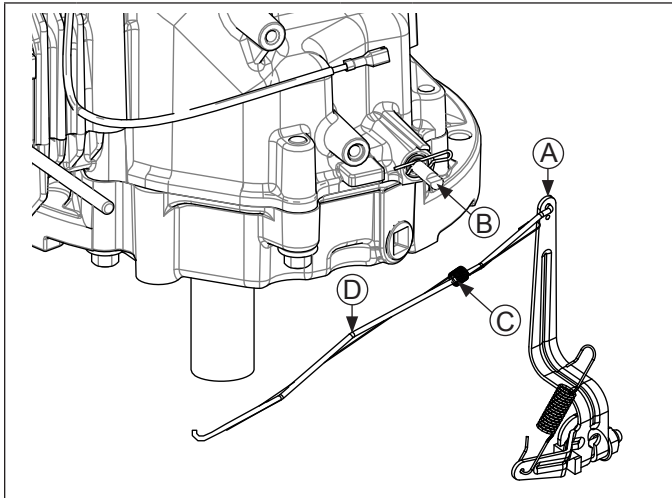

1. Install governor lever onto governor shaft with lever up.
2. Attach throttle linkage and linkage spring to top of governor lever.

Install Speed Control Bracket Assembly

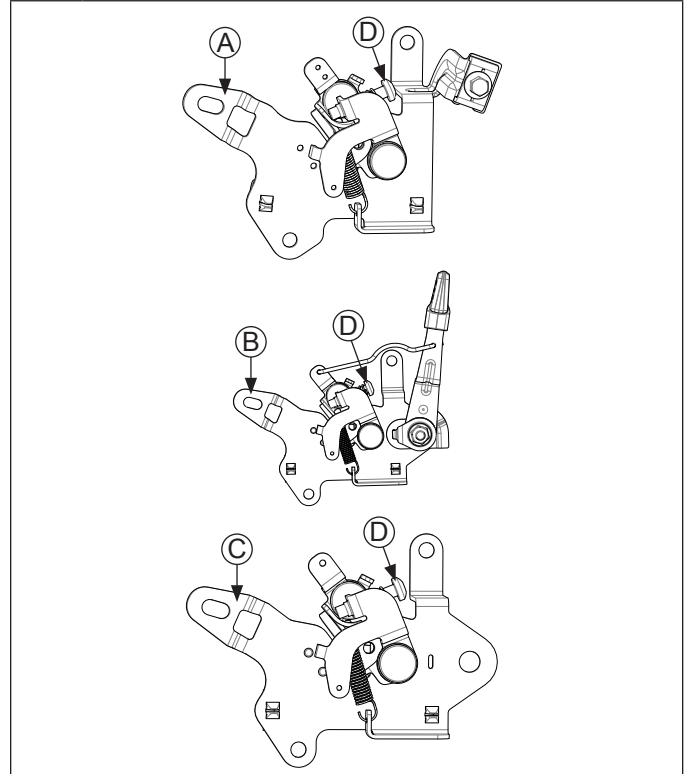

NOTE: There are 3 different speed bracket variations for this engine.

Secure speed control bracket (with fuel hose in plastic clips mounted on back of speed control bracket) to crankcase. Torque screws to 8 N·m (71 in. lb.).

Install Governor Spring

Install governor spring between governor lever and speed control bracket.

Install Carburetor and Gaskets

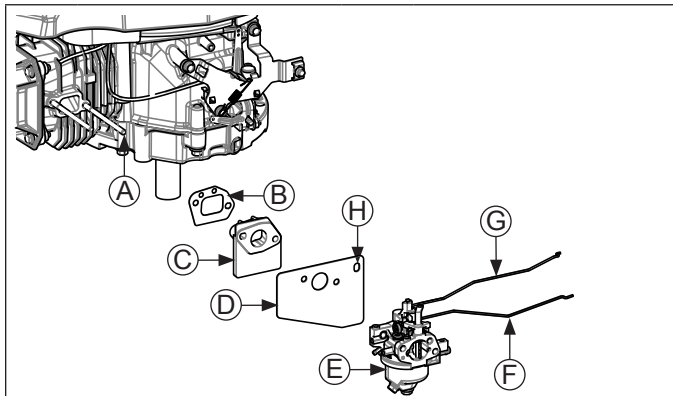

A	Carburetor Stud	B	Spacer Gasket
C	Carburetor Spacer	D	Carburetor Heat Shield Gasket
E	Carburetor	F	Choke Linkage
G	Throttle Linkage	H	Ignition Kill Lead Slot

Install Carburetor Gaskets

1. Place new spacer gasket then carburetor spacer on carburetor studs.
2. For engines that have a speed control bracket equipped with a stop switch, slide ignition kill lead through slot in carburetor heat shield gasket and install gasket on carburetor studs.

Install Carburetor and Linkages

1. Move throttle control clockwise to full choke position, and slide carburetor onto studs while connecting choke linkage.
2. Turn throttle lever clockwise until it stops. Gently push rod and spring linkages up to connect them to throttle lever.
3. If equipped, connect ignition kill lead terminal to stop switch on speed control assembly.

Reconnect Fuel Line

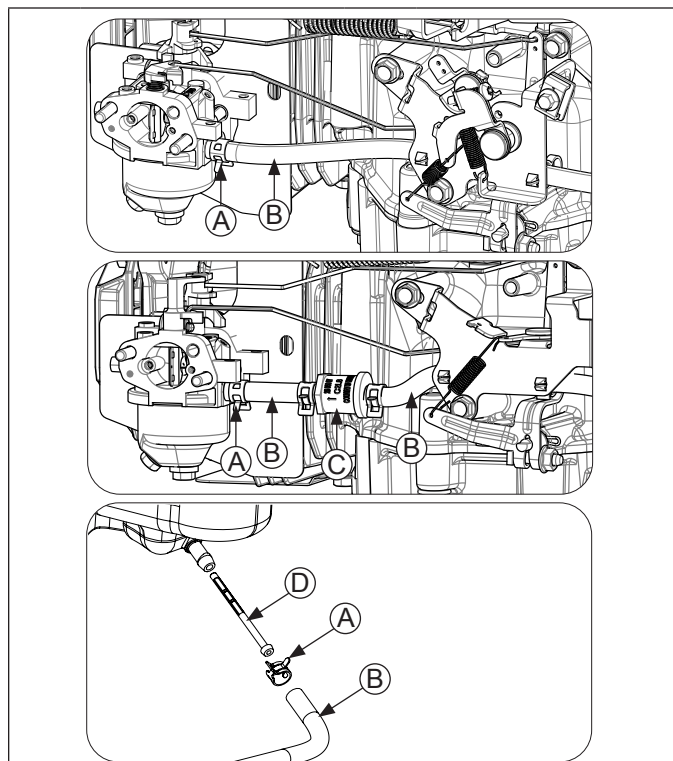

A	Hose Clamp	B	Fuel Line
C	Fuel Filter (if equipped)	D	In-nipple Fuel Filter

1. Slide fuel line tight up against carburetor, and secure connection with a hose clamp.
2. Ensure that in-nipple fuel filter is in place in fuel tank outlet.
3. Connect fuel line to fuel tank and slide hose clamp to secure.

Reassembly

Install Air Cleaner Assembly

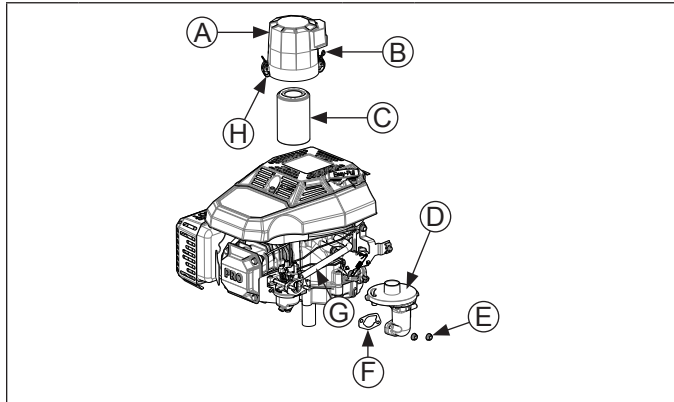

A	Air Cleaner Cover	B	Bail
C	Paper Element and Foam Precleaner	D	Air Cleaner Base Assembly
E	Nut	F	Gasket
G	Breather Hose	H	Latch

1. Slide new air cleaner gasket onto carburetor studs. Ensure vent holes are open.
2. Slide air cleaner base assembly onto carburetor studs. Secure base assembly by starting nuts onto studs.
3. Torque nuts to 8 N·m (71 in. lb.).
4. Attach breather hose to air cleaner base assembly.
5. Install paper element and foam precleaner (if equipped) onto air cleaner base. Install air cleaner cover and place latches under tabs on base; lift up bails to secure cover.

Adjust Governor

Move governor lever away from carburetor to limit of its travel (wide-open throttle), and hold in this position. Do not stress, flex or distort linkage. Grasp cross shaft with a pliers and turn shaft clockwise as far as it will go, hold and tighten nut. Torque nut to 9.5 N·m (84 in. lb.).

Install Blower Housing and Engine Cover

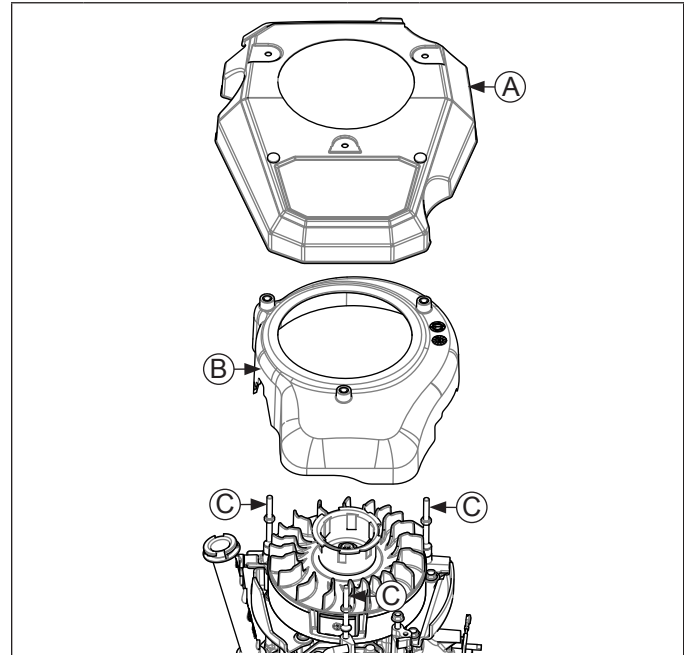

A	Engine Cover	B	Blower Housing
C	Stud		

1. Install blower housing onto studs.
2. Install engine cover onto studs.

Install Retractable Starter

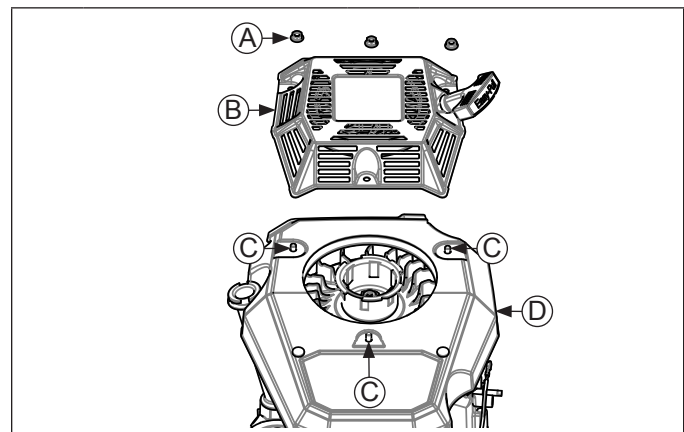

A	Nut	B	Retractable Starter
C	Stud	D	Engine Cover

Place retractable starter onto studs and secure with nuts. Torque to 8 N·m (71 in. lb.).

Install Muffler Assembly

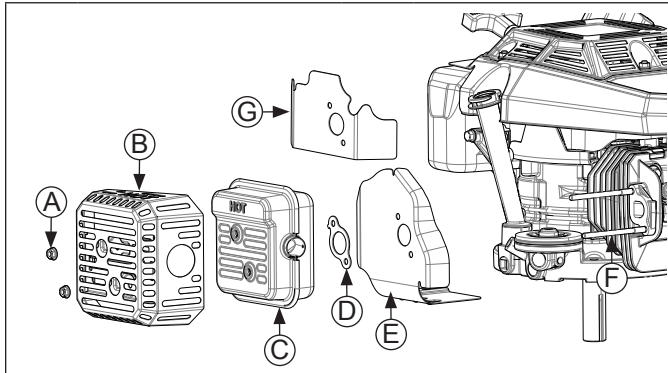

A	Nut	B	Muffler Guard
C	Muffler	D	Muffler Gasket (CV200, CV224)
E	Barrel Baffle (CV200, CV224)	F	Exhaust Stud
G	Muffler Gasket (CV173)		

1. On CV200 & CV224 engines, slide barrel baffle onto exhaust studs. Tighten screw to secure barrel baffle to cylinder. Torque screw to 8 N·m (71 in. lb.).
2. Install new muffler gasket onto exhaust studs.
3. Slide muffler onto exhaust studs.
4. Install muffler guard onto exhaust studs and secure with nuts. Torque to 9.5 N·m (84 in. lb.).

Install Oil Drain Plug, Oil Filter, and Oil

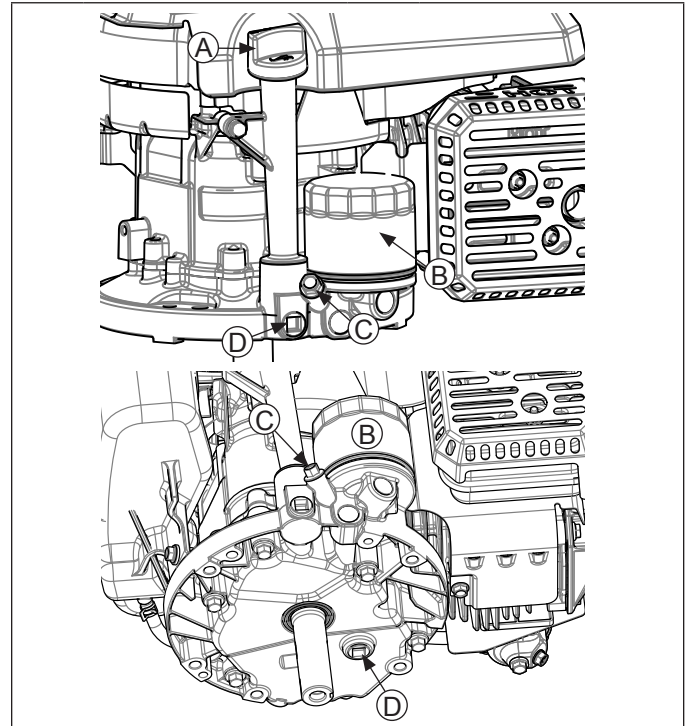

A	Oil Fill Cap/Dipstick	B	Oil Filter
C	Clean Oil Change Screw	D	Drain Plug

1. Apply thread sealant around three full threads of drain plug; reinstall drain plug. Torque to 13.6 N·m (120 in. lb.).
2. Reinstall clean oil change screw. Torque to 14.7 N·m (130 in. lb.).
3. Apply a thin film of clean oil to rubber gasket on new filter.
4. Refer to instructions on oil filter for proper installation.
5. Fill crankcase with new oil. Level should be at top of indicator on dipstick. Refer to Maintenance and Lubrication System for oil recommendations and procedures.
6. Reinstall oil fill cap/dipstick and tighten securely.

Install Fuel Cap

Screw fuel cap tightly onto fuel tank.

Reassembly

Prepare Engine for Operation

Engine is now reassembled. Before starting or operating engine be sure to do following:

1. Make sure all hardware is properly torqued.
2. Make sure oil drain plugs are tightened securely.
3. Ensure crankcase is filled with correct oil.

Connect Spark Plug Lead

Connect lead to spark plug.

Testing Engine

NOTE: Engine can be installed in application and speeds can be checked/set.

1. Run engine for 5-10 minutes between idle and mid-range. Adjust throttle and choke controls and high speed screw on speed control bracket as necessary. Make sure maximum engine speed does not exceed recommended RPM.

For CV173 engines high speed is 3300 RPM.

For CV200, CV224 engines high speed is 3500 RPM.

2. Adjust carburetor low idle speed screw so low idle speed is set to 1800 RPM or application specifications. Refer to Fuel System.



1P14 690 12



8 85612 79664 6