

Command

HD675, HD775

Service Manual

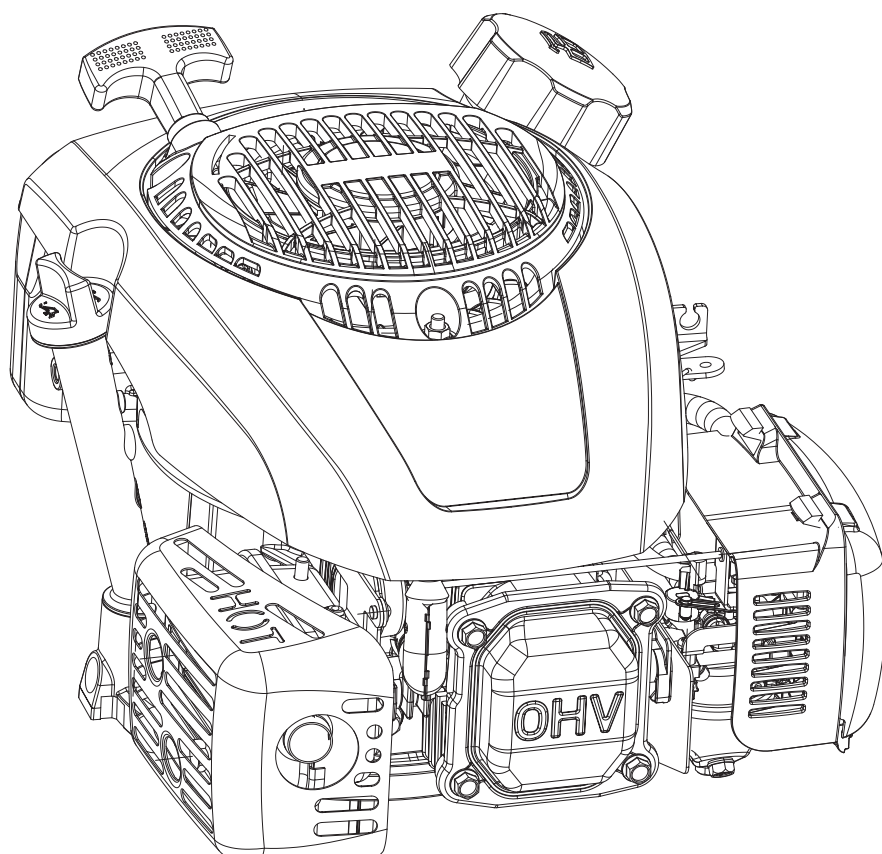

Rehlko Engines
is now Rehlko.

2	Safety
3	Maintenance
5	Specifications
12	Tools and Aids
15	Troubleshooting
20	Air Cleaner/Intake
21	Fuel System
28	Governor System
30	Lubrication System
32	Electrical System
38	Starter System
42	Disassembly/Inspection and Service
55	Reassembly

IMPORTANT: Read all safety precautions and instructions carefully before operating equipment. Refer to operating instruction of equipment that this engine powers.

Ensure engine is stopped and level before performing any maintenance or service.

Safety

SAFETY PRECAUTIONS

⚠ WARNING: A hazard that could result in death, serious injury, or substantial property damage.

⚠ CAUTION: A hazard that could result in minor personal injury or property damage.

NOTE: is used to notify people of important installation, operation, or maintenance information.

	⚠ WARNING
	Explosive Fuel can cause fires and severe burns. Do not fill fuel tank while engine is hot or running.
Gasoline is extremely flammable and its vapors can explode if ignited. Store gasoline only in approved containers, in well ventilated, unoccupied buildings, away from sparks or flames. Spilled fuel could ignite if it comes in contact with hot parts or sparks from ignition. Never use gasoline as a cleaning agent.	

	⚠ WARNING
	Rotating Parts can cause severe injury. Stay away while engine is in operation.
Keep hands, feet, hair, and clothing away from all moving parts to prevent injury. Never operate engine with covers, shrouds, or guards removed.	

	⚠ WARNING
	Carbon Monoxide can cause severe nausea, fainting or death. Avoid inhaling exhaust fumes. Never run engine indoors or in enclosed spaces.
Engine exhaust gases contain poisonous carbon monoxide. Carbon monoxide is odorless, colorless, and can cause death if inhaled.	

	⚠ WARNING
	Accidental Starts can cause severe injury or death. Disconnect and ground spark plug lead(s) before servicing.
Before working on engine or equipment, disable engine as follows: 1) Disconnect spark plug lead(s). 2) Disconnect negative (-) battery cable from battery.	

	⚠ WARNING
	Hot Parts can cause severe burns. Do not touch engine while operating or just after stopping.
Never operate engine with heat shields or guards removed.	



	⚠ WARNING
	Cleaning Solvents can cause severe injury or death. Use only in well ventilated areas away from ignition sources.
Carburetor cleaners and solvents are extremely flammable. Follow cleaner manufacturer's warnings and instructions on its proper and safe use. Never use gasoline as a cleaning agent.	

	⚠ CAUTION
	Electrical Shock can cause injury. Do not touch wires while engine is running.

	⚠ CAUTION
	Damaging Crankshaft and Flywheel can cause personal injury.
Using improper procedures can lead to broken fragments. Broken fragments could be thrown from engine. Always observe and use precautions and procedures when installing flywheel.	

	⚠ WARNING
	Uncoiling Spring can cause severe injury. Wear safety goggles or face protection when servicing retractable starter.
Retractable starters contain a powerful, recoil spring that is under tension. Always wear safety goggles when servicing retractable starters and carefully follow instructions in Retractable Starter for relieving spring tension.	

MAINTENANCE INSTRUCTIONS

  	⚠ WARNING	Before working on engine or equipment, disable engine as follows: 1) Disconnect spark plug lead(s). 2) Disconnect negative (-) battery cable from battery.
	Accidental Starts can cause severe injury or death. Disconnect and ground spark plug lead(s) before servicing.	

Normal maintenance, replacement or repair of emission control devices and systems may be performed by any repair establishment or individual; however, warranty repairs must be performed by a Rehlko authorized dealer.

MAINTENANCE SCHEDULE

Before every Use

<ul style="list-style-type: none"> • Check oil level. Add oil if low. Do not overfill. 	Lubrication System
<ul style="list-style-type: none"> • Check air cleaner for dirty, loose, or damaged parts. 	Air Cleaner/Intake
<ul style="list-style-type: none"> • Check precleaner for dirty or torn material. 	Air Cleaner/Intake

After first 3-5 Hours (approximately 3rd to 5th use)

<ul style="list-style-type: none"> • Change oil. 	Lubrication System
---	--------------------

Every 25 Hours or Annually¹

<ul style="list-style-type: none"> • Service/replace precleaner. 	Air Cleaner/Intake
---	--------------------

Every 50 Hours or Annually¹

<ul style="list-style-type: none"> • Change oil. 	Lubrication System
<ul style="list-style-type: none"> • Replace air cleaner element. 	Air Cleaner/Intake
<ul style="list-style-type: none"> • Replace fuel filter (if equipped). 	

Every 100 Hours or Annually¹

<ul style="list-style-type: none"> • Clean spark arrestor (if equipped). 	
---	--

Every 125 Hours or Annually¹

<ul style="list-style-type: none"> • Replace spark plug and set gap. 	Electrical System
---	-------------------

¹ Perform these procedures more frequently under severe, dusty, dirty conditions.

REPAIRS/SERVICE PARTS

Rehlko genuine service parts can be purchased from Rehlko authorized dealers. To find a local Rehlko authorized dealer visit Engines.rehlko.com or call 1-800-544-2444 (U.S. and Canada).

Maintenance

OIL RECOMMENDATIONS

We recommend use of Rehlko oils for best performance. Other high-quality detergent oils (including synthetic) of API (American Petroleum Institute) service class SJ or higher are acceptable. Select viscosity based on air temperature at time of operation as shown in table below.

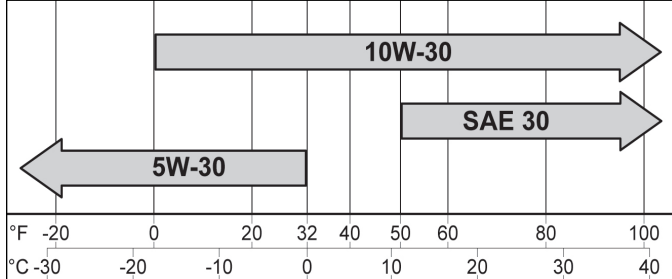

FUEL RECOMMENDATIONS

	WARNING
	Explosive Fuel can cause fires and severe burns. Do not fill fuel tank while engine is hot or running.
Gasoline is extremely flammable and its vapors can explode if ignited. Store gasoline only in approved containers, in well ventilated, unoccupied buildings, away from sparks or flames. Spilled fuel could ignite if it comes in contact with hot parts or sparks from ignition. Never use gasoline as a cleaning agent.	

NOTE: E15, E20 and E85 are NOT approved and should NOT be used; effects of old, stale or contaminated fuel are not warrantable.

Fuel must meet these requirements:

- Clean, fresh, unleaded gasoline.
- Octane rating of 87 (R+M)/2 or higher.
- Research Octane Number (RON) 90 octane minimum.
- Gasoline up to 10% ethyl alcohol, 90% unleaded is acceptable.
- Methyl Tertiary Butyl Ether (MTBE) and unleaded gasoline blend (max 15% MTBE by volume) are approved.
- Do not add oil to gasoline.
- Do not overfill fuel tank.
- Do not use gasoline older than 30 days.

STORAGE

If engine will be out of service for 2 months or more follow procedure below.

1. Add Rehlko fuel treatment or equivalent to fuel tank. Run engine 2-3 minutes to get stabilized fuel into fuel system (failures due to untreated fuel are not warrantable).
2. Change oil while engine is still warm from operation. Remove spark plug(s) and pour about 1 oz. of engine oil into cylinder(s). Replace spark plug(s) and crank engine slowly to distribute oil.
3. Disconnect battery or negative (-) battery cable (if equipped).
4. Store engine in a clean, dry place.

ENGINE IDENTIFICATION NUMBERS

Rehiko engine identification numbers (model, specification and serial) should be referenced for efficient repair, ordering correct parts, and engine replacement.

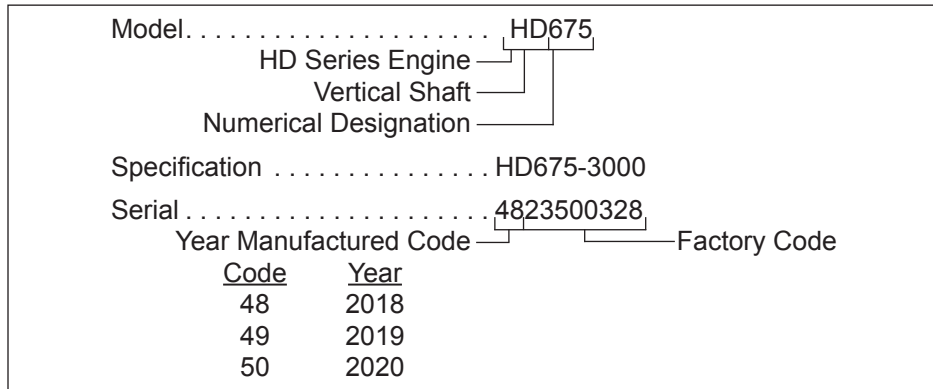

GENERAL SPECIFICATIONS^{2,4}

	HD675	HD775
Bore	65 mm (2.6 in.)	70 mm (2.8 in.)
Stroke	45 mm (1.8 in.)	
Displacement	149 cc (9.1 cu. in.)	173 cc (10.6 cu. in.)
Oil Capacity (refill)	0.6 L (20 oz.)	
Maximum Angle of Operation (@ full oil level) ³	20°	

TORQUE SEQUENCES

(Refer to Torque Specifications for torque values.)

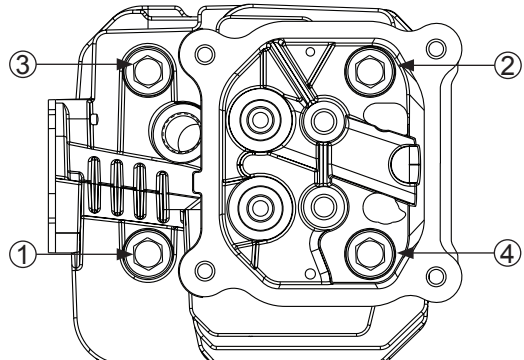
	HD675	HD775
Cylinder Head Fasteners		

² Values are in Metric units. Values in parentheses are English equivalents.

³ Exceeding maximum angle of operation may cause engine damage from insufficient lubrication.

⁴ Any and all horsepower (hp) references by Rehiko are Certified Power Ratings and per SAE J1940 & J1995 hp standards. Details on Certified Power Ratings can be found at Engines.rehiko.com.

Specifications

TORQUE SEQUENCES

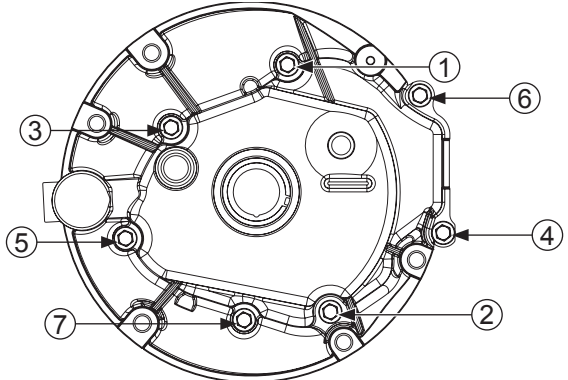
	HD675	HD775
HD675 Oil Pan Fasteners		

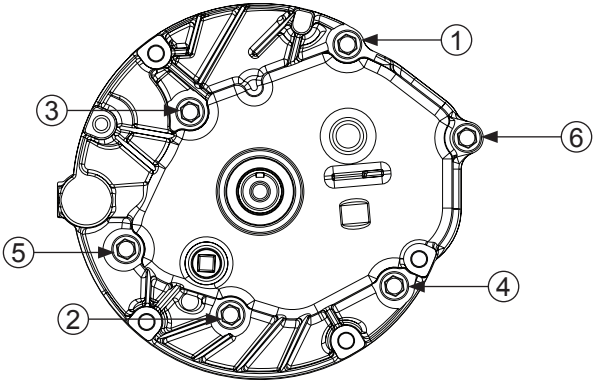
HD775 Oil Pan Fasteners		
-------------------------	---	--

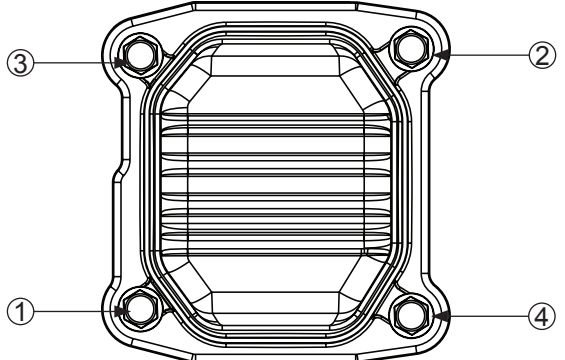
Valve Cover Fasteners		
-----------------------	--	--

TORQUE SPECIFICATIONS^{2,5}

	HD675	HD775
Air Cleaner Base		
Stud Fastener	8 N·m (71 in. lb.)	
Crankcase Fastener	8 N·m (71 in. lb.)	
Blower Housing		
Stud	10 N·m (89 in. lb.)	
Nut	8 N·m (71 in. lb.)	

² Values are in Metric units. Values in parentheses are English equivalents.

⁵ Lubricate threads with engine oil prior to assembly.

TORQUE SPECIFICATIONS^{2,5}

HD675

HD775

Brake (if equipped)

Mounting Fastener	9.5 N·m (84 in. lb.)
-------------------	----------------------

Breather Cover

Fastener	10 N·m (89 in. lb.)
----------	---------------------

Carburetor

Stud Fastener	8 N·m (71 in. lb.)
Stud	5 N·m (44 in. lb.)
Auto Choke Arm Assembly Nut (if equipped)	8.5 N·m (75 in. lb.)
Auto Choke Arm Assembly Screw (if equipped)	2.3 N·m (20 in. lb.)

Connecting Rod

Cap Fastener (torque in increments)	12.5 N·m (110 in. lb.)
-------------------------------------	------------------------

Cylinder Head (torque sequence on page 5)

Fastener (torque in 2 increments)	first to 14 N·m (123 in. lb.) finally to 27.8 N·m (246 in. lb.)
-----------------------------------	--

Dipstick Tube (if equipped)

Fastener	8 N·m (71 in. lb.)
----------	--------------------

Electric Starter (if equipped)

Fastener	9.5 N·m (84 in. lb.)
----------	----------------------

Finger Guard (as equipped)

Fastener (Muffler Side, Carburetor Side)	9.5 N·m (84 in. lb.)
--	----------------------

Flywheel

Retaining Nut	51.5 N·m (38 ft. lb.)
---------------	-----------------------

Fuel Pump (if equipped)

Pump to Bracket Fastener	2.3 N·m (20 in. lb.)
Stud (into crankcase)	10 N·m (89 in. lb.)
Lock Nut (Bracket to Studs)	8 N·m (71 in. lb.)

Fuel Tank

Stud	10 N·m (71 in. lb.)
Lower Tank Bracket to Crankcase Screw	8 N·m (71 in. lb.)

Governor

Lever Fastener	9.5 N·m (84 in. lb.)
Gear Fastener	9.5 N·m (84 in. lb.)

Ignition

Spark Plug	27 N·m (20 ft. lb.)
Module Fastener (Stud or Screw)	10 N·m (89 in. lb.)
Stator Screw (if equipped)	9.5 N·m (84 in. lb.)

² Values are in Metric units. Values in parentheses are English equivalents.

⁵ Lubricate threads with engine oil prior to assembly.

Specifications

TORQUE SPECIFICATIONS^{2,5}

HD675

HD775

Muffler

Exhaust Stud	5.0 N·m (44 in. lb.)	
Lock Nut	9.5 N·m (84 in. lb.)	
Shoulder Screw	9.5 N·m (84 in. lb.)	

Oil Pan (torque sequence on page 6)

Oil Drain Plug ⁶	13.6 N·m (120 in. lb.)	
Fastener	11.0 N·m (98 in. lb.)	14.7 N·m (130 in. lb.)

Retractable Starter

Fastener	8 N·m (71 in. lb.)	
----------	--------------------	--

Rocker Arm

Stud	13.6 N·m (120 in. lb.)	
Pivot Jam Nut	9.5 N·m (84 in. lb.)	

Speed Control

Bracket Assembly Fastener	8 N·m (71 in. lb.)	
---------------------------	--------------------	--

Valve Cover (torque sequence on page 6)

Fastener	8 N·m (71 in. lb.)	
----------	--------------------	--

CLEARANCE SPECIFICATIONS²

HD675

HD775

Camshaft

End Play	0.3/0.85 mm (0.0118/0.0335 in.)	
Running Clearance	0.013/0.0555 mm (0.00051/0.00217 in.)	

Connecting Rod

Connecting Rod-to-Crankpin Running Clearance New	0.025/0.045 mm (0.0009/0.0017 in.)	
Connecting Rod-to-Crankpin Side Clearance New	0.03/0.48 mm (0.00118/0.0189 in.)	0.13/0.58 mm (0.0051/0.0228 in.)
Connecting Rod-to-Piston Pin Running Clearance	0.008/0.025 mm (0.0003/0.0009 in.)	
Piston Pin End I.D. New @ 21°C (70°F)	13.006/13.017 mm (0.5120/0.5125 in.)	18.006/18.017 mm (0.7088/0.7093 in.)

Crankcase

Governor Cross Shaft Bore I.D. New	6.000/6.024 mm (0.2362/0.2372 in.)	
---------------------------------------	------------------------------------	--

² Values are in Metric units. Values in parentheses are English equivalents.

⁵ Lubricate threads with engine oil prior to assembly.

⁶ Apply thread sealant around three full threads before assembly. No excess sealant allowed on inside or outside of joint. Threads with preapplied sealant do not require use of additional sealant. Approved sealants include Perma-Loc LH 150, Perma-Loc MM 115, Perma-Loc HH 120, Perma-Loc HL 126.

CLEARANCE SPECIFICATIONS²

HD675

HD775

Crankshaft

End Play (free)	0.427/1.298 mm (0.0168/0.05110 in.)	
Bore in Oil Pan I.D.	27.050/27.071 mm (1.06496/1.06578 in.)	
Bore in Oil Pan Running Clearance	0.008/0.121 mm (0.0031/0.00476 in.)	
Bearing (flywheel) Journal O.D.	25.005/25.019 mm (0.9844/0.9850 in.)	24.975/24.989 mm (0.9832/0.9838 in.)
Max. Taper	0.025 mm (0.0009 in.)	0.025 mm (0.0009 in.)
Max. Out-of-Round	0.025 mm (0.0009 in.)	0.025 mm (0.0009 in.)
Bearing (PTO) Journal O.D.	26.95/26.97 mm (1.061/1.062 in.)	
Max. Taper	0.025 mm (0.0009 in.)	
Max. Out-of-Round	0.025 mm (0.0009 in.)	
Connecting Rod Journal O.D.	25.985/25.995 mm (1.0230/1.0234 in.)	
New	25.985/25.995 mm (1.0230/1.0234 in.)	29.985/29.995 mm (1.1805/1.1809 in.)
Max. Taper	0.010 mm (0.0004 in.)	0.010 mm (0.0004 in.)
Max. Out-of-Round	0.010 mm (0.0004 in.)	0.010 mm (0.0004 in.)

Cylinder Bore

Bore I.D.	65.00/65.02 mm (2.559/2.560 in.)	70.00/70.02 mm (2.755/2.756 in.)
Max. Out-of-Round	0.0127 mm (0.0005 in.)	
Max. Taper	0.0127 mm (0.0005 in.)	

Cylinder Head

Max. Out-of-Flatness	0.08 mm (0.003 in.)
----------------------	---------------------

Governor

Governor Cross Shaft -to-Crankcase Running Clearance	0.020/0.064 mm (0.0007/0.0025 in.)
Cross Shaft O.D.	5.96/5.98 mm (0.2346/0.2354 in.)
New	5.96/5.98 mm (0.2346/0.2354 in.)
Gear Shaft O.D.	6.01/6.03 mm (0.2366/0.2374 in.)
New	6.01/6.03 mm (0.2366/0.2374 in.)
Governor Gear Shaft-to-Governor Gear Running Clearance	0.09/0.19 mm (0.0035/0.0074 in.)

Ignition

Spark Plug Gap	0.76 mm (0.030 in.)
Module Air Gap	0.254 mm (0.010 in.)

² Values are in Metric units. Values in parentheses are English equivalents.

Specifications

CLEARANCE SPECIFICATIONS²

HD675

HD775

Piston, Piston Rings, and Piston Pin



Pin Bore I.D.	13.002/13.008 mm (0.5118/0.5121 in.)	18.000/18.008 mm (0.7086/0.7089 in.)
Pin O.D.	12.990/12.996 mm (0.5114/0.5116 in.)	17.990/17.996 mm (0.7082/0.7085 in.)
Top and Center Compression Ring Side Clearance New Bore	0.001/0.020 mm (0.00004/0.00080 in.)	
Top and Center Compression Ring End Gap New Bore		
Top	0.1/0.25 mm (0.0039/0.0098 in.)	0.1/0.25 mm (0.0039/0.0098 in.)
Center	0.61/0.76 mm (0.0240/0.0299 in.)	0.3/0.5 mm (0.0118/0.0197 in.)
Thrust Face O.D.	64.975/64.985 mm (0.2558/0.2558 in.)	69.960/69.980 mm (2.7543/2.7551 in.)
Piston Thrust Face-to-Cylinder Bore Running Clearance	0.025/0.035 mm (0.0010/0.0014 in.)	0.020/0.060 mm (0.0007/0.0024 in.)

Valves and Valve Lifters





Intake and Exhaust Valve Lash	0.0762/0.127 mm (0.003/0.005 in.)
Intake Valve Stem-to-Valve Guide Running Clearance	0.020/0.047 mm (0.0007/0.0018 in.)
Exhaust Valve Stem-to-Valve Guide Running Clearance	0.055/0.082 mm (0.0021/0.0032 in.)
Intake Valve Guide I.D.	5.500/5.512 mm (0.2165/0.2170 in.)
Intake Valve Stem Diameter	5.465/5.480 mm (0.2151/0.2157 in.)
Exhaust Valve Guide I.D.	5.500/5.512 mm (0.2165/0.2170 in.)
Exhaust Valve Stem Diameter	5.430/5.445 mm (0.2137/0.2143 in.)
Nominal Valve Face Angle	25°, 45°, 60°

²Values are in Metric units. Values in parentheses are English equivalents.

GENERAL TORQUE VALUES

English Fastener Torque Recommendations for Standard Applications				
Bolts, Screws, Nuts and Fasteners Assembled Into Cast Iron or Steel				Grade 2 or 5 Fasteners Into Aluminum
Size	 Grade 2	 Grade 5	 Grade 8	
Tightening Torque: N·m (in. lb.) ± 20%				
8-32	2.3 (20)	2.8 (25)	—	2.3 (20)
10-24	3.6 (32)	4.5 (40)	—	3.6 (32)
10-32	3.6 (32)	4.5 (40)	—	—
1/4-20	7.9 (70)	13.0 (115)	18.7 (165)	7.9 (70)
1/4-28	9.6 (85)	15.8 (140)	22.6 (200)	—
5/16-18	17.0 (150)	28.3 (250)	39.6 (350)	17.0 (150)
5/16-24	18.7 (165)	30.5 (270)	—	—
3/8-16	29.4 (260)	—	—	—
3/8-24	33.9 (300)	—	—	—

Tightening Torque: N·m (ft. lb.) ± 20%				
5/16-24	—	—	40.7 (30)	—
3/8-16	—	47.5 (35)	67.8 (50)	—
3/8-24	—	54.2 (40)	81.4 (60)	—
7/16-14	47.5 (35)	74.6 (55)	108.5 (80)	—
7/16-20	61.0 (45)	101.7 (75)	142.5 (105)	—
1/2-13	67.8 (50)	108.5 (80)	155.9 (115)	—
1/2-20	94.9 (70)	142.4 (105)	223.7 (165)	—
9/16-12	101.7 (75)	169.5 (125)	237.3 (175)	—
9/16-18	135.6 (100)	223.7 (165)	311.9 (230)	—
5/8-11	149.5 (110)	244.1 (180)	352.6 (260)	—
5/8-18	189.8 (140)	311.9 (230)	447.5 (330)	—
3/4-10	199.3 (147)	332.2 (245)	474.6 (350)	—
3/4-16	271.2 (200)	440.7 (325)	637.3 (470)	—

Metric Fastener Torque Recommendations for Standard Applications						
Size	Property Class					Noncritical Fasteners Into Aluminum
	 4.8	 5.8	 8.8	 10.9	 12.9	
Tightening Torque: N·m (in. lb.) ± 10%						
M4	1.2 (11)	1.7 (15)	2.9 (26)	4.1 (36)	5.0 (44)	2.0 (18)
M5	2.5 (22)	3.2 (28)	5.8 (51)	8.1 (72)	9.7 (86)	4.0 (35)
M6	4.3 (38)	5.7 (50)	9.9 (88)	14.0 (124)	16.5 (146)	6.8 (60)
M8	10.5 (93)	13.6 (120)	24.4 (216)	33.9 (300)	40.7 (360)	17.0 (150)
Tightening Torque: N·m (ft. lb.) ± 10%						
M10	21.7 (16)	27.1 (20)	47.5 (35)	66.4 (49)	81.4 (60)	33.9 (25)
M12	36.6 (27)	47.5 (35)	82.7 (61)	116.6 (86)	139.7 (103)	61.0 (45)
M14	58.3 (43)	76.4 (56)	131.5 (97)	184.4 (136)	219.7 (162)	94.9 (70)

Torque Conversions	
N·m = in. lb. x 0.113	in. lb. = N·m x 8.85
N·m = ft. lb. x 1.356	ft. lb. = N·m x 0.737

Tools and Aids

Certain quality tools are designed to help you perform specific disassembly, repair, and reassembly procedures. By using these tools, you can properly service engines easier, faster, and safer! In addition, you'll increase your service capabilities and customer satisfaction by decreasing engine downtime.

Here is a list of tools and their source.

NOTE: Not all tools listed are required to service this engine.

SEPARATE TOOL SUPPLIERS

Rehiko Tools
Contact your local Rehiko source of supply.

SE Tools
415 Howard St.
Lapeer, MI 48446
Phone 810-664-2981
Toll Free 800-664-2981
Fax 810-664-8181

Design Technology Inc.
768 Burr Oak Drive
Westmont, IL 60559
Phone 630-920-1300
Fax 630-920-0011

TOOLS

Description	Source/Part No.
Alcohol Content Tester For testing alcohol content (%) in reformulated/oxygenated fuels.	Rehiko 25 455 11-S
Camshaft Endplay Plate For checking camshaft endplay.	SE Tools KLR-82405
Camshaft Seal Protector (Aegis) For protecting seal during camshaft installation.	SE Tools KLR-82417
Dual Gauge Cylinder Leakdown Tester For checking combustion retention and if cylinder, piston, rings, or valves are worn. Individual component available: Adapter 12 mm x 14 mm (Required for leakdown test on XT-6 engines)	Rehiko 25 761 46-S Design Technology Inc. DTI-731-03
Dealer Tool Kit Complete kit of Rehiko required tools. Components of 25 761 39-S Ignition System Tester Dual Gauge Cylinder Leakdown Test Tool Oil Pressure Test Kit Digital Vacuum/Pressure Tester	Rehiko 25 761 39-S Rehiko 25 455 01-S Rehiko 25 761 46-S Rehiko 25 761 06-S Rehiko 25 455 22-S
Digital Vacuum/Pressure Tester For checking crankcase vacuum. Individual component available: Rubber Adapter Plug	Rehiko 25 455 22-S Design Technology Inc. DTI-721-10
EFI Service Kit For troubleshooting and setting up an EFI engine. Components of 24 761 01-S Fuel Pressure Tester Noid Light 90° Adapter Code Plug, Red Wire Code Plug, Blue Wire Code Plug, Yellow Wire Can Bus Reset Tool, Green Wire Shrader Valve Adapter Hose Wire Probe Set (2 pieces regular wire with clip; 1 piece fused wire) Hose Removal Tool, Dual Size/End (also sold as individual Rehiko tool) K-Line Adapter Jumper Lead Wiring Harness	Rehiko 24 761 01-S Design Technology Inc. DTI-019 DTI-021 DTI-023 DTI-027 DTI-029 DTI-028 DTI-030 DTI-037 DTI-031 DTI-033 Rehiko 25 176 23-S
Rehiko® Diagnostic System (KDS) Gen 2 For Laptop or Desktop PC. Components of 25 761 50-S Engine Communication Module 7 Pin to DB9 Cable USB Module to PC Cable 7 Pin to 4 Pin Adapter	Rehiko 25 761 50-S Rehiko 25 761 47-S Rehiko 25 761 48-S Rehiko 25 761 49-S Rehiko 25 761 53-S
Mobile KDS (Wireless) Module For mobile Android or iOS EFI diagnostics. Individual component available: Wireless Diagnostic System Interface Cable	Rehiko 25 761 45-S Rehiko 25 761 44-S

TOOLS

Description	Source/Part No.
Flywheel Puller For properly removing flywheel from engine.	SE Tools KLR-82408
Flywheel Anchor Bolts, Washers, Nuts Tool Used with Flywheel Puller for properly removing flywheel from 5400 Series engine.	Rehiko 25 086 753-S
Hose Removal Tool, Dual Size/End (also available in EFI Service Kit) Used to properly remove fuel hose from engine components.	Rehiko 25 455 20-S
Ignition System Tester For testing output on all systems, including CD.	Rehiko 25 455 01-S
Inductive Tachometer (Digital) For checking operating speed (RPM) of an engine.	Design Technology Inc. DTI-110
Oil Pressure Test Kit For testing/verifying oil pressure on pressure lubricated engines.	Rehiko 25 761 06-S
Rectifier-Regulator Tester (120 volt current) Rectifier-Regulator Tester (240 volt current) For testing rectifier-regulators. Components of 25 761 20-S and 25 761 41-S CS-PRO Regulator Test Harness Special Regulator Test Harness with Diode	Rehiko 25 761 20-S Rehiko 25 761 41-S Design Technology Inc. DTI-031R DTI-033R
Spark Advance Module (SAM) Tester For testing SAM (ASAM and DSAM) on engines with SMART-SPARK™.	Rehiko 25 761 40-S
Starter Servicing Kit (All Starters) For removing and reinstalling drive retaining rings and brushes. Individual component available: Starter Brush Holding Tool (Solenoid Shift)	SE Tools KLR-82411 SE Tools KLR-82416
Stepper Motor Controller Tool For testing operation of stepper motor/Digital Linear Actuator (DLA).	Rehiko 25 455 21-S
Jumper Lead Tool For use with Stepper Motor Controller Tool to test rotary stepper motor.	Rehiko 25 518 43-S
Triad/OHC Timing Tool Set For holding cam gears and crankshaft in timed position while installing timing belt.	Rehiko 28 761 01-S
Valve Guide Reamer (K and M Series) For properly sizing valve guides after installation.	Design Technology Inc. DTI-K828
Valve Guide Reamer O.S. (Command Series) For reaming worn valve guides to accept replacement oversize valves. Can be used in low-speed drill press or with handle below for hand reaming.	Rehiko 25 455 12-S
Reamer Handle For hand reaming using Rehiko 25 455 12-S reamer.	Design Technology Inc. DTI-K830

AIDS

Description	Source/Part No.
Camshaft Lubricant (Valspar ZZ613)	Rehiko 25 357 14-S
Dielectric Grease (GE/Novaguard G661)	Rehiko 25 357 11-S
Dielectric Grease	Loctite® 51360
Rehiko Electric Starter Drive Lubricant (Inertia Drive)	Rehiko 52 357 01-S
Rehiko Electric Starter Drive Lubricant (Solenoid Shift)	Rehiko 52 357 02-S
RTV Silicone Sealant Loctite® 5900® Heavy Body in 4 oz. aerosol dispenser. Only oxime-based, oil resistant RTV sealants, such as those listed, are approved for use. Permatex® the Right Stuff® 1 Minute Gasket™ or Loctite® Nos. 5900® or 5910® are recommended for best sealing characteristics. When Permatex® Ultra Grey® is to be used, this will be stated in Reassembly section.	Rehiko 25 597 07-S Loctite® 5910® Loctite® Ultra Black 598™ Loctite® Ultra Blue 587™ Loctite® Ultra Copper 5920™ Permatex® the Right Stuff® 1 Minute Gasket™
Spline Drive Lubricant	Rehiko 25 357 12-S

Tools and Aids

FLYWHEEL HOLDING TOOL

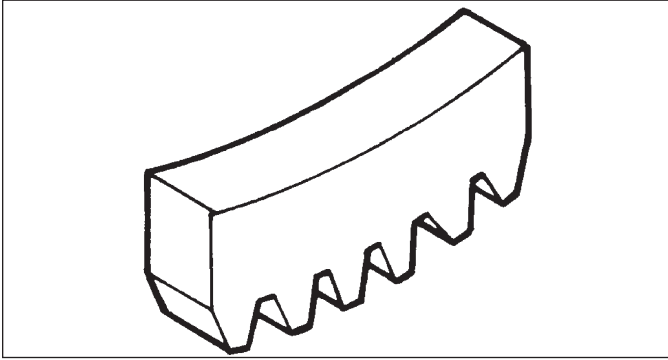

A flywheel holding tool can be made out of an old junk flywheel ring gear and used in place of a strap wrench.

1. Using an abrasive cut-off wheel, cut out a six tooth segment of ring gear as shown.
2. Grind off any burrs or sharp edges.
3. Invert segment and place it between ignition bosses on crankcase so tool teeth engage flywheel ring gear teeth. Bosses will lock tool and flywheel in position for loosening, tightening, or removing with a puller.

ROCKER ARM/CRANKSHAFT TOOL

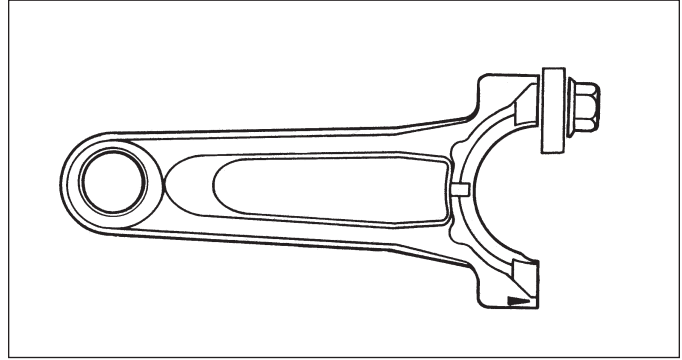

A spanner wrench to lift rocker arms or turn crankshaft may be made out of an old junk connecting rod.

1. Find a used connecting rod from a 10 HP or larger engine. Remove and discard rod cap.
2. Remove studs of a Posi-Lock rod or grind off aligning steps of a Command rod, so joint surface is flat.
3. Find a 1 in. long capscrew with correct thread size to match threads in connecting rod.
4. Use a flat washer with correct I.D. to slip on capscrew and approximately 1 in. O.D. Assemble capscrew and washer to joint surface of rod.

TROUBLESHOOTING GUIDE

When troubles occur, be sure to check simple causes which, at first, may seem too obvious to be considered. For example, a starting problem could be caused by an empty fuel tank.

Some general common causes of engine troubles are listed below and vary by engine specification. Use these to locate causing factors.

Engine Cranks But Will Not Start

- Battery connected backwards.
- Blown fuse.
- Choke not closing.
- Clogged fuel line or fuel filter.
- Empty fuel tank.
- Faulty spark plug.
- Fuel pump malfunction-vacuum hose clogged or leaking.
- Fuel shut-off valve closed (if equipped).
- Ignition module faulty or improperly gapped.
- Interlock switch is engaged or faulty (if equipped).
- Key switch or kill switch in OFF position.
- Quality of fuel (dirt, water, stale, mixture).
- Spark plug lead disconnected.

Engine Starts But Does Not Keep Running

- Faulty carburetor.
- Faulty cylinder head gasket.
- Faulty or misadjusted choke or throttle controls.
- Fuel pump malfunction-vacuum hose clogged or leaking.
- Intake system leak.
- Loose wires or connections that intermittently ground ignition kill circuit.
- Quality of fuel (dirt, water, stale, mixture).
- Restricted fuel tank cap vent.

Engine Starts Hard

- Clogged fuel line or fuel filter.
- Engine overheated.
- Faulty ACR mechanism.
- Faulty or misadjusted choke or throttle controls.
- Faulty spark plug.
- Flywheel key sheared.
- Fuel pump malfunction-vacuum hose clogged or leaking.
- Interlock switch is engaged or faulty (if equipped).
- Loose wires or connections that intermittently ground ignition kill circuit.
- Low compression.
- Quality of fuel (dirt, water, stale, mixture).
- Weak spark.

Engine Will Not Crank

- Battery is discharged.
- Faulty electric starter or solenoid.
- Faulty key switch or ignition switch.
- Interlock switch is engaged or faulty (if equipped).
- Loose wires or connections that intermittently ground ignition kill circuit.
- Pawls not engaging in drive cup.
- Seized internal engine components.

Engine Runs But Misses

- Carburetor adjusted incorrectly.
- Engine overheated.
- Faulty spark plug.
- Ignition module faulty or improperly gapped.
- Interlock switch is engaged or faulty (if equipped).
- Loose wires or connections that intermittently ground ignition kill circuit.
- Quality of fuel (dirt, water, stale, mixture).
- Spark plug lead boot loose on plug.
- Spark plug lead loose.

Engine Will Not Idle

- Engine overheated.
- Faulty spark plug.
- Idle fuel circuit in carburetor plugged/restricted.
- Idle speed adjusting screw improperly set.
- Inadequate fuel supply.
- Low compression.
- Quality of fuel (dirt, water, stale, mixture).
- Restricted fuel tank cap vent.

Engine Overheats

- Cooling fan broken.
- Excessive engine load.
- High crankcase oil level.
- Lean fuel mixture.
- Low crankcase oil level.
- Cooling system components clogged or restricted.

Engine Knocks

- Excessive engine load.
- Incorrect oil viscosity/type.
- Internal wear or damage.
- Low crankcase oil level.
- Quality of fuel (dirt, water, stale, mixture).

Engine Loses Power

- Dirty air cleaner element.
- Engine overheated.
- Excessive engine load.
- Restricted exhaust.
- Faulty spark plug.
- High crankcase oil level.
- Incorrect governor setting.
- Low compression.
- Low crankcase oil level.
- Quality of fuel (dirt, water, stale, mixture).

Troubleshooting

Engine Uses Excessive Amount of Oil

- Loose or improperly torqued fasteners.
- Blown head gasket/overheated.
- Breather reed broken.
- Clogged, broken, or inoperative crankcase breather.
- Crankcase overfilled.
- Incorrect oil viscosity/type.
- Worn cylinder bore.
- Worn or broken piston rings.
- Worn valve stems/valve guides.

Oil Leaks from Oil Seals, Gaskets

- Breather reed broken.
- Clogged, broken, or inoperative crankcase breather.
- Loose or improperly torqued fasteners.
- Piston blow by, or leaky valves.
- Restricted exhaust.

EXTERNAL ENGINE INSPECTION

NOTE: It is good practice to drain oil at a location away from workbench. Be sure to allow ample time for complete drainage.

Before cleaning or disassembling engine, make a thorough inspection of its external appearance and condition. This inspection can give clues to what might be found inside engines (and cause) when it is disassembled.

- Check for buildup of dirt and debris on crankcase, cooling fins, grass screen, and other external surfaces. Dirt or debris on these areas can cause overheating.
- Check for obvious fuel and oil leaks, and damaged components. Excessive oil leakage can indicate a clogged or inoperative breather, worn or damaged seals or gaskets, or loose fasteners.
- Check air cleaner cover and base for damage or indications of improper fit and seal.
- Check air cleaner element. Look for holes, tears, cracked or damaged sealing surfaces, or other damage that could allow unfiltered air into engine. A dirty or clogged element could indicate insufficient or improper maintenance.
- Check carburetor throat for dirt. Dirt in throat is further indication that air cleaner was not functioning properly.
- Check if oil level is within operating range on dipstick. If it is above, sniff for gasoline odor.
- Check condition of oil. Drain oil into a container; it should flow freely. Check for metal chips and other foreign particles.

Sludge is a natural by-product of combustion; a small accumulation is normal. Excessive sludge formation could indicate over rich fuel settings, weak ignition, overextended oil change interval or wrong weight or type of oil was used.

CLEANING ENGINE

	⚠ WARNING
	Cleaning Solvents can cause severe injury or death. Use only in well ventilated areas away from ignition sources.
Carburetor cleaners and solvents are extremely flammable. Follow cleaner manufacturer's warnings and instructions on its proper and safe use. Never use gasoline as a cleaning agent.	

After inspecting external condition of engine, clean engine thoroughly before disassembly. Clean individual components as engine is disassembled. Only clean parts can be accurately inspected and gauged for wear or damage. There are many commercially available cleaners that will quickly remove grease, oil, and grime from engine parts. When such a cleaner is used, follow manufacturer's instructions and safety precautions carefully.

Make sure all traces of cleaner are removed before engine is reassembled and placed into operation. Even small amounts of these cleaners can quickly break down lubricating properties of engine oil.

CRANKCASE VACUUM TEST

	⚠ WARNING
	Carbon Monoxide can cause severe nausea, fainting or death. Avoid inhaling exhaust fumes. Never run engine indoors or in enclosed spaces.
Engine exhaust gases contain poisonous carbon monoxide. Carbon monoxide is odorless, colorless, and can cause death if inhaled.	

	⚠ WARNING
	Rotating Parts can cause severe injury. Stay away while engine is in operation.
Keep hands, feet, hair, and clothing away from all moving parts to prevent injury. Never operate engine with covers, shrouds, or guards removed.	

A partial vacuum should be present in crankcase when engine is operating. Pressure in crankcase (normally caused by a clogged or improperly assembled breather) can cause oil to be forced out at oil seals, gaskets, or other available spots.

Crankcase vacuum is best measured with either a water manometer or a vacuum gauge (inches of water gauge only). Complete instructions are provided in kits.

To test crankcase vacuum with manometer:

1. Insert rubber stopper into oil fill hole. Be sure pinch clamp is installed on hose and use tapered adapters to connect hose between stopper and one manometer tube. Leave other tube open to atmosphere. Check that water level in manometer is at 0 line. Make sure pinch clamp is closed.
2. Start engine and run no-load high speed.
3. Open clamp and note water level in tube.
Level in engine side should be a minimum of 10.2 cm (4 in.) above level in open side.
If level in engine side is less than specified (low/no vacuum), or level in engine side is lower than level in open side (pressure), check for conditions in table below.
4. Close pinch clamp before stopping engine.

To test crankcase vacuum with vacuum/pressure gauge (inches of water gauge only):

1. Remove dipstick or oil fill plug/cap.
2. Install adapter into oil fill//dipstick tube opening, upside down over end of a small diameter dipstick tube, or directly into engine if a tube is not used. Insert barbed gauge fitting into hole in stopper.
3. Run engine and observe gauge reading.
Analog tester—needle movement to left of 0 is a vacuum, and movement to right indicates a pressure.
Digital tester—depress test button on top of tester.
Crankcase vacuum should be a minimum of 10.2 cm (4 in.) of water. If reading is below specification, or if pressure is present, check table below for possible causes and conclusions.

Condition	Conclusion
Crankcase breather clogged or inoperative.	NOTE: If breather is integral part of valve cover and cannot be serviced separately, replace valve cover and recheck pressure. Disassemble breather, clean parts thoroughly, check sealing surfaces for flatness, reassemble, and recheck pressure.
Seals and/or gaskets leaking. Loose or improperly torque fasteners.	Replace all worn or damaged seals and gaskets. Make sure all fasteners are tightened securely. Use appropriate torque values and sequences when necessary.
Piston blow by or leaky valves (confirm by inspecting components).	Recondition piston, rings, cylinder bore, valves and valves guides.
Restricted exhaust.	Check exhaust screen/spark arrestor (if equipped). Clean or replace as needed. Repair or replace any other damaged/restricted muffler or exhaust system parts.

Troubleshooting

COMPRESSION TEST

These engines are equipped with an automatic compression release (ACR) mechanism. It is difficult to obtain an accurate compression reading because of ACR mechanism. As an alternative, use cylinder leakdown test described below.

CYLINDER LEAKDOWN TEST

A cylinder leakdown test can be a valuable alternative to a compression test. By pressurizing combustion chamber from an external air source you can determine if valves or rings are leaking, and how badly.

Cylinder leakdown tester is a relatively simple, inexpensive leakdown tester for small engines. This tester includes a quick-connect for attaching adapter hose and a holding tool.

Dual Gauge Test Procedure

1. Run engine until oil temperature reaches and maintains 150°F (66°C) or more for a minimum of 5 minutes. Ideally, engine should be run under normal load conditions.
2. Remove spark plug(s) and air filter from engine.
3. Rotate crankshaft until piston (of cylinder being tested) is at top dead center (TDC) of compression stroke. Hold engine in this position while testing. Holding tool from kit can be used if PTO end of crankshaft is accessible. Lock holding tool onto crankshaft. Install a 3/8 in. breaker bar into hole/slot of holding tool, so it is perpendicular to both holding tool and crankshaft PTO.

If flywheel end is more accessible, use a breaker bar and socket on flywheel nut/screw to hold it in position. An assistant may be needed to hold breaker bar during testing. If engine is mounted in a piece of equipment, it may be possible to hold it by clamping or wedging a driven component. Just be certain engine cannot rotate off TDC in either direction.

4. Connect an air source (at least 100 PSI) to tool.
5. Turn regulator knob clockwise (increase direction). Confirm both gauges read approximately the same air pressure from 0 to 80 PSI. Note any discrepancies between gauges for leakage calculation. Release pressure by turning regulator knob completely counterclockwise before proceeding.
6. Install adapter hose into spark plug hole of cylinder being tested. Use 12 mm x 14 mm adapter if required.
7. Firmly hold engine at TDC. Connect other end of adapter hose to tool quick connect. Turn regulator knob clockwise (increase direction) until left gauge needle reads 20 PSI.

NOTE: When piston is at TDC, little to no holding force should be required when air pressure is applied to cylinder. If excess holding force is required, this indicates piston is not at TDC. Readjust as necessary before proceeding.

8. Slowly turn regulator knob clockwise until left hand gauge maintains selected test pressure (see chart below).

Left Gauge Regulated Pressure Selection
80 PSI Recommended for engines over 200 cc or those exhibiting high leakage at 35 PSI setting.
35 PSI Recommended for single cylinder walk-behind push mower applications.

9. Compare right gauge reading to Test Pressure Chart on next page to identify percentage of leakage. Also refer to Leakdown Test Results chart on next page for colors, conditions, and action required.
10. For engines exhibiting leakage in yellow or red zone, repeat test procedure. Operate engine under normal load conditions prior to test. Confirm piston is at TDC during test.

NOTE: To prevent damage to gauge assembly, always turn pressure regulator knob to zero (counterclockwise) after each test.

Test Pressure Chart for Dual Gauge Tool

Left Gauge Regulated Pressure Selection	Right Gauge Reading in PSI											
80 PSI Recommended for engines over 200 cc or those exhibiting high leakage at 35 PSI setting.	80	72	64	56	48	40	32	24	16	8	0	
35 PSI Recommended for single cylinder walk-behind push mower applications.	35	31.5	28	24.5	21	17.5	14	10.5	7	3.5	0	
Percentage of leakage	0%	10%	20%	30%	40%	50%	60%	70%	80%	90%	100%	
	Green Zone				Yellow Zone				Red Zone			

Leakdown Test Results

Test Result	Condition	Action
Gauge reading in low (green) zone.	Piston rings and cylinder in good condition.	No further action required.
Gauge reading in moderate (yellow) zone.	Air escaping from crankcase breather and/or dipstick tube.	Some wear present causing leakage from combustion chamber to crankcase. Repair not required at this time if breather system is functioning normally.
	Air escaping from exhaust.	Exhaust valve leakage present, possibly due to carbon deposits. Repair not required. Carbon cleaning could be performed to reduce leakage.
	Air escaping from intake.	Intake valve leakage present, possibly due to carbon deposits. Repair not required. Carbon cleaning could be performed to reduce leakage.
Gauge reading in high (red) zone. Confirm consecutive leakdown test has been performed AFTER engine has been operated under normal load conditions.	Air escaping from crankcase breather and/or dipstick tube.	Excess wear present causing leakage from combustion chamber to crankcase. Breather system will not function normally and will fail crankcase vacuum test if this condition is truly present. Engine disassembly and analysis required to determine root cause and correction.
	Air escaping from exhaust.	Excess exhaust valve leakage present, possibly due to carbon deposits and/or valve to seat sealing issues. Carbon cleaning may reduce leakage. Valve grind and/or component replacement may be necessary. Excess oil consumption and/or excess heat is a suspect cause and must be resolved to prevent reoccurrence.
	Air escaping from intake.	Excess intake valve leakage present, possibly due to carbon deposits and/or valve to seat sealing issues. Carbon cleaning may reduce leakage. Valve grind and/or component replacement may be necessary. Excess oil consumption through intake valve and/or excess heat is a suspect cause and must be resolved to prevent reoccurrence. Inspect breather system components and intake valve stem sealing.

Air Cleaner/Intake

AIR CLEANER

These systems are CARB/EPA certified and components should not be altered or modified in any way.

Air Cleaner Components

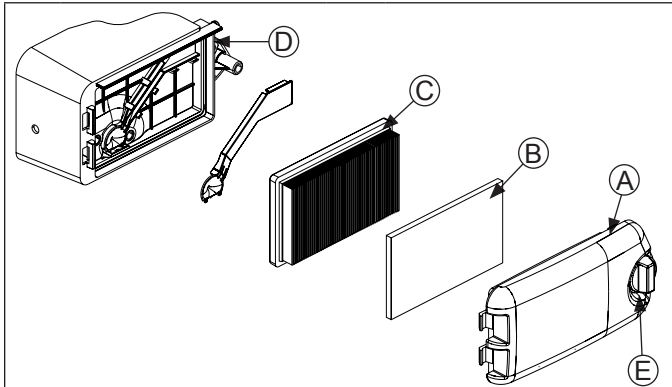

A	Air Cleaner Cover	B	Precleaner
C	Paper Element	D	Base
E	Air Cleaner Knob		

NOTE: Operating engine with loose or damaged air cleaner components could cause premature wear and failure. Replace all bent or damaged components.

NOTE: Paper element cannot be blown out with compressed air.

Loosen knob and remove air cleaner cover.

Precleaner (if equipped)

1. Remove precleaner.
2. Replace or wash precleaner in warm water with detergent. Rinse and allow to air dry.
3. Reinstall precleaner into cover, aligning hole in precleaner with upper cover knob.

Paper Element

1. Remove paper element from base and replace.
2. Install element with pleated side out and seat rubber seal onto edges of base.

Reinstall air cleaner cover and secure with knob.

BREATHER TUBE

Make sure both ends of breather tube are properly connected.

AIR COOLING

	WARNING
	Hot Parts can cause severe burns. Do not touch engine while operating or just after stopping.
Never operate engine with heat shields or guards removed.	

Proper cooling is essential. To prevent over heating, clean screens, cooling fins, and other external surfaces of engine. Avoid spraying water at wiring harness or any electrical components. Refer to Maintenance Schedule.

Typical carbureted fuel system and related components include:

- Fuel tank.
- Fuel lines.
- In-line fuel filter (if equipped).
- In-nipple fuel filter (if equipped).
- Fuel shut-off valve (if equipped).
- Carburetor.
- Fuel pump (if equipped) and second in-nipple fuel filter after tee fitting.

Fuel tank outlet is located above carburetor inlet, allowing gravity to feed fuel through in-line filter and fuel line to carburetor.

Engines equipped with a pulse fuel pump allows for complete fuel usage. Engines operated at extreme cylinder head up angles of operation restrict complete fuel tank volume usage in gravity feed mode due to angle of engine. Addition of pulse pump aids in drawing and delivering full tank of fuel to carburetor.

Fuel enters carburetor through fuel shut-off valve (if equipped) and then goes to carburetor float bowl. Fuel is drawn into carburetor body and mixed with air. This fuel-air mixture is then burned in engine combustion chamber.

FUEL RECOMMENDATIONS

Refer to Maintenance.

FUEL LINE

Low permeation fuel line must be installed on carbureted Rehlko engines to maintain EPA and CARB regulatory compliance.

FUEL SHUT-OFF (if equipped)

Some engines are equipped with a fuel shut-off located at carburetor. It controls fuel flow from tank to carburetor.

FUEL PUMP (if equipped)

C	Tee Fitting	D	Second In-Nipple Fuel Filter
E	Pulse	F	Outlet
G	Fuel Pump Bracket	H	Fuel Pump

Some engines use a pulse style fuel pump. Pumping action of pulse style pumps is created by oscillation of positive and negative pressures within crankcase. This pressure is transmitted to pulse pump through rubber hose connected between pump and crankcase. Pumping action causes diaphragm on inside of pump to pull fuel in on its downward stroke and to push it into carburetor on its upward stroke. Two check valves prevent fuel from going backward through pump.

Repair

Pulse fuel pumps are not serviceable and must be replaced when faulty.

Fuel Pump Replacement

NOTE: Make sure orientation of new pump is consistent with removed pump. Internal damage may occur if installed incorrectly.

To replace pulse fuel pump follow these steps. Note orientation of pump before removing.

1. Disconnect fuel lines from inlet, outlet, and pulse fittings on fuel pump.
2. Inspect both in-nipple fuel filters (located at fuel tank outlet fitting and tee fitting) for dirt/debris. Clean/replace as required.
3. Remove screws securing fuel pump to bracket and take off pump.
4. Connect pulse line to new fuel pump and make sure opposite end is properly connected to fitting in valve cover.
5. Secure new fuel pump to bracket using screws. Torque screws to 2.3 N·m (20 in. lb.).
6. Connect fuel lines to inlet and outlet fittings and secure with clamps.

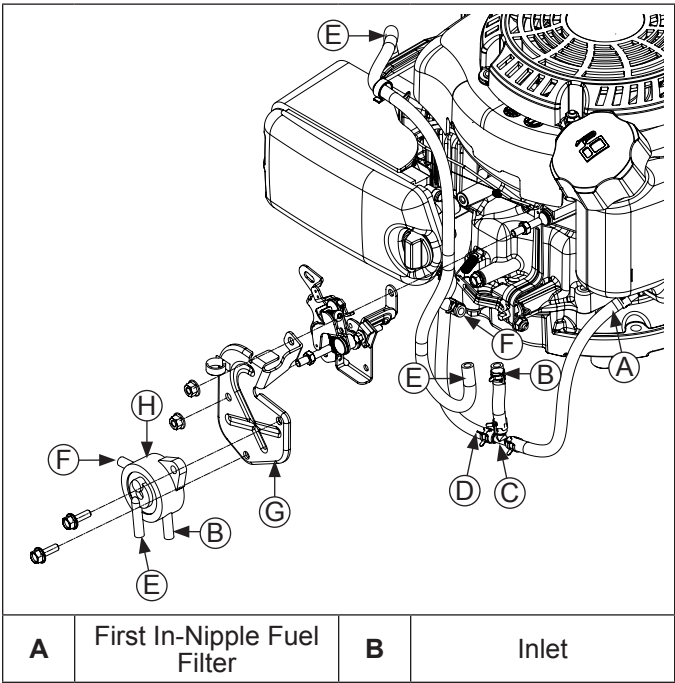

Fuel System

FUEL SYSTEM TESTS

When engine starts hard, or turns over but will not start, fuel system might be causing problems. Test fuel system by performing following tests.



1. Check for fuel in combustion chamber.
 - a. Disconnect and ground spark plug lead.
 - b. Close choke on carburetor.
 - c. Crank engine several times.
 - d. Remove spark plug and check for fuel at tip.
2. Check for fuel flow from tank to carburetor.
 - a. Remove fuel line from inlet fitting of carburetor.
 - b. Use an approved fuel container to catch fuel, and hold line below bottom of tank to observe fuel flow. If engine has in-line fuel filter and no fuel flows, replace filter.
 - c. Remove fuel line from outlet fitting of fuel tank. Check in-nipple fuel filter and clean/replace as required.
3. Check operation of fuel shut-off valve (if equipped).
 - a. Turn fuel shut-off valve ON and OFF and observe operation.

Engines equipped with pulse fuel pump:

4. Check for fuel flow from tank to fuel pump.
 - a. Remove fuel line from inlet fitting of fuel pump.
 - b. Hold line below bottom of tank and observe flow. If no fuel flow, proceed to step c.
 - c. Remove fuel line from outlet fitting of fuel tank. Check in-nipple fuel filter and clean/replace as required.
5. Check operation of fuel pump.
 - a. Remove fuel line from inlet fitting of carburetor.
 - b. Hold line from carburetor above fuel tank level. Crank engine several times and observe flow. If no fuel flow, proceed to step c.
 - c. Remove fuel line from tee fitting and check in-nipple fuel filter. Clean/replace as required.
6. Check for a clogged fuel line. If line is unobstructed, check for crankcase vacuum (refer to Troubleshooting Crankcase Vacuum Test), check for overfilled crankcase and/or oil in pulse line. If checks don't reveal cause of problem, replace pump.

Condition	Conclusion
Fuel at tip of spark plug.	Fuel is reaching combustion chamber.
No fuel at tip of spark plug.	Check fuel flow from fuel tank (step 2).
Fuel flows from fuel line.	Check operation of fuel shut-off valve (step 3).
No fuel flow from fuel line.	Check fuel tank vent, in-nipple fuel filter, and fuel line. Correct any observed problem and reconnect line.
Fuel flows from valve.	Check for faulty carburetor, refer to Carburetor.
No fuel flows from valve.	Check for a restriction in fuel shut-off valve or inlet elbow.

CARBURETOR

	 WARNING	Gasoline is extremely flammable and its vapors can explode if ignited. Store gasoline only in approved containers, in well ventilated, unoccupied buildings, away from sparks or flames. Spilled fuel could ignite if it comes in contact with hot parts or sparks from ignition. Never use gasoline as a cleaning agent.
	Explosive Fuel can cause fires and severe burns. Do not fill fuel tank while engine is hot or running.	

Typical One-Barrel Carburetor Components

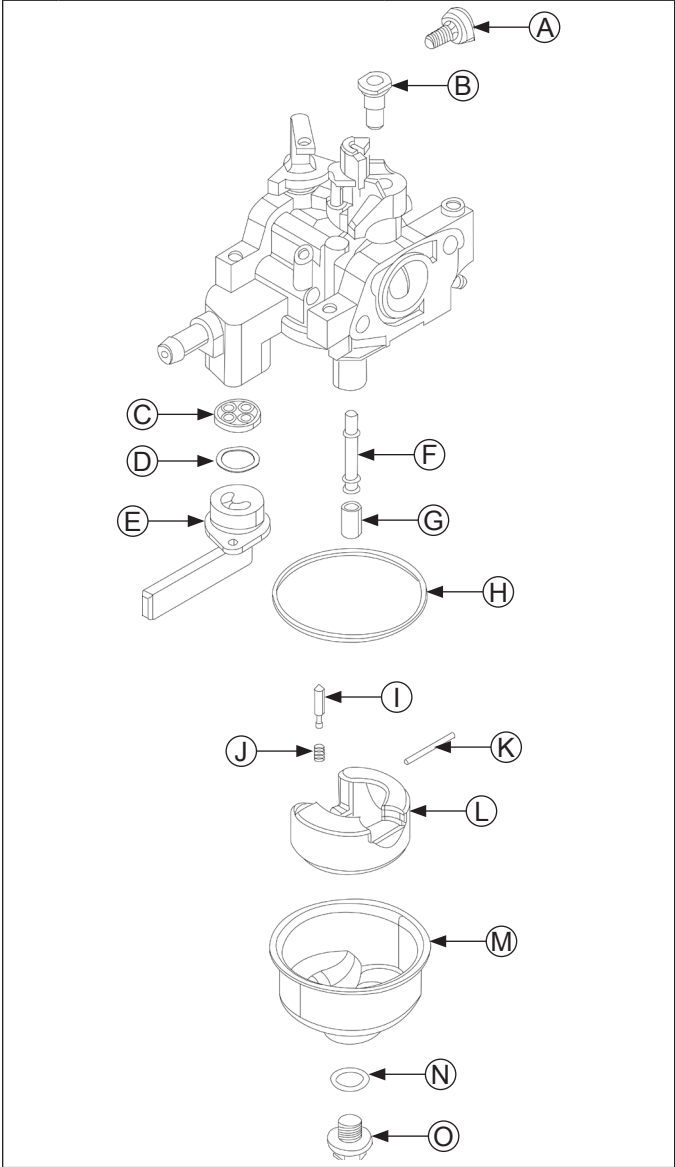

A	Low Idle Speed Adjusting Screw	B	Idle Jet
C	Fuel Shut-Off Gasket	D	Wave Washer
E	Fuel Shut-Off Valve (if equipped)	F	Main Nozzle Tube
G	Main Jet	H	Bowl Gasket
I	Fuel Inlet Needle	J	Spring
K	Hinge Pin	L	Float

M	Fuel Bowl	N	Bowl Retaining Screw Gasket
O	Bowl Retaining Screw		

These engines are equipped with a fixed main jet carburetor. Carburetor is designed to deliver correct fuel-to-air mixture to engine under all operating conditions. Idle mixture is set at factory and cannot be adjusted.

Troubleshooting Checklist

- When engine starts hard, runs rough, or stalls at low idle speed, check these areas before adjusting or disassembling carburetor.
1. Make sure fuel tank is filled with clean, fresh gasoline.
 2. Make sure fuel tank cap vent is not blocked and is operating properly.
 3. Make sure fuel is reaching carburetor. This includes checking fuel shut-off valve, fuel tank filter screen, in-line fuel filter, fuel lines and fuel pump for restrictions or faulty components as necessary.
 4. Make sure air cleaner base and carburetor are securely fastened to engine using gaskets in good condition.
 5. Make sure air cleaner element (including pre-cleaner if equipped) is clean and all air cleaner components are fastened securely.
 6. Make sure ignition system, governor system, exhaust system, and throttle and choke controls are operating properly.

Fuel System

Troubleshooting-Carburetor Related Causes

Condition	Possible Cause	Conclusion
Engine starts hard, runs rough, or stalls at idle speed.	Low idle fuel mixture (some models)/ speed improperly adjusted.	Adjust idle speed screw or clean carburetor.
Engine runs rich (indicated by black, sooty exhaust smoke, misfiring, loss of speed and power, governor hunting, or excessive throttle opening).	Clogged air cleaner.	Clean or replace air cleaner.
	Choke partially closed during operation.	Check choke lever/linkage to ensure choke is operating properly.
	Dirt under fuel inlet needle.	Remove needle; clean needle and seat and blow with compressed air.
	Bowl vent or air bleeds plugged.	Clean vent, ports, and air bleeds. Blow out all passages with compressed air.
	Leaky, cracked, or damaged float.	Submerge float to check for leaks.
Engine runs lean (indicated by misfiring, loss of speed and power, governor hunting, or excessive throttle opening).	Idle holes plugged; dirt in fuel delivery channels.	Clean main fuel jet and all passages; blow out with compressed air.
Fuel leaks from carburetor.	Float damaged.	Submerge float to check for leaks. Replace float.
	Dirt under fuel inlet needle.	Remove needle; clean needle and seat and blow with compressed air.
	Bowl vents plugged.	Blow out with compressed air.
	Carburetor bowl gasket leaks.	Replace gasket.

Carburetor Circuits

Float

Fuel level in bowl is maintained by float and fuel inlet needle. Buoyant force of float stops fuel flow when engine is at rest. When fuel is being consumed, float will drop and fuel pressure will push inlet needle away from seat, allowing more fuel to enter bowl. When demand ceases, buoyant force of float will again overcome fuel pressure, rising to predetermined setting and stop flow.

Slow and Mid-Range

At low speeds engine operates only on slow circuit. As a metered amount of air is drawn through slow air bleed jets, fuel is drawn through main jet and further metered through slow jet. Air and fuel are mixed in body of slow jet and exit to idle progression (transfer port) chamber. From idle progression chamber, air fuel mixture is metered through idle port passage. At low idle air/fuel mixture is controlled by setting of idle fuel adjusting screws. This mixture is then mixed with main body of air and delivered to engine. As throttle plate opening increases, greater amounts of air/fuel mixture are drawn in through fixed and metered idle progression holes. As throttle plate opens further, vacuum signal becomes great enough at venturi so main circuit begins to work.

Main (high-speed)

At high speeds/loads engine operates on main circuit. As a metered amount of air is drawn through air jet, fuel is drawn through main jet. Air and fuel are mixed in main nozzles then enters main body of airflow where further mixing of fuel and air occurs. This mixture is then delivered to combustion chamber. Carburetor has a fixed main circuit; no adjustment is possible.

Carburetor Adjustments

NOTE: Carburetor adjustments should be made only after engine has warmed up.



Carburetor is designed to deliver correct fuel-to-air mixture to engine under all operating conditions. Main fuel jet is calibrated at factory and is not adjustable. Idle fuel adjusting needles are also set at factory and are not adjustable.

Low Idle Speed (RPM) Adjustment (variable speed only)

NOTE: Actual low idle speed depends on application and engine features. Refer to equipment manufacturer's recommendations or use online parts lookup system (www.Rehлкоplus.com site) to locate idle speed listed in Attributes on Details tab of engine specification.

Place throttle control into idle or slow position. Turn low idle speed adjusting screw in or out to obtain appropriate idle speed.

Carburetor Servicing

	 WARNING
	<p>Accidental Starts can cause severe injury or death.</p> <p>Disconnect and ground spark plug lead(s) before servicing.</p>
<p>Before working on engine or equipment, disable engine as follows: 1) Disconnect spark plug lead(s). 2) Disconnect negative (-) battery cable from battery.</p>	

NOTE: Main and slow jets are fixed and size specific and can be removed if required. Fixed jets for high altitudes are available.

- Inspect carburetor body for cracks, holes, and other wear or damage.
- Inspect float for cracks, holes, and missing or damaged float tabs. Check float hinge and shaft for wear or damage.
- Inspect fuel inlet needle and seat for wear or damage.

1. Perform removal procedures for appropriate air cleaner and carburetor outlined in Disassembly.
2. Clean exterior surfaces of dirt or foreign material before disassembling carburetor. Remove bowl retaining screws, and carefully separate fuel bowl from carburetor. Do not damage fuel bowl O-rings. Transfer any remaining fuel into an approved container. Save all parts. Fuel can also be drained prior to bowl removal by loosening/removing bowl drain screw.
3. Remove float pin and inlet needle. Seat for inlet needle is not serviceable and should not be removed.
4. Clean carburetor bowl and inlet seat areas as required.
5. Carefully remove main jet from carburetor. After main jet is removed, main nozzles can be removed through bottom of main towers. Note orientation/direction of nozzles. End with 2 raised shoulders should be out/down adjacent to main jets.
6. Save parts for cleaning and reuse unless a jet kit is also being installed. Clean slow jets using compressed air or carburetor cleaner, do not use wire.

NOTE: There are 2 O-rings on body of idle jet.

Carburetor is now disassembled for appropriate cleaning and installation of parts in overhaul kit. See instructions provided with repair kits for more detailed information.

High Altitude Operation

If this engine is operated at an altitude of 4000 ft. (1219 meters) or above, a high altitude carburetor kit is required. To obtain high altitude carburetor kit information or to find a Rehlko authorized dealer, visit Engines.rehlko.com or call 1-800-544-2444 (U.S. and Canada).

This engine should be operated in its original configuration below 4000 ft. (1219 meters).

Operating this engine with the wrong engine configuration at a given altitude may increase its emissions, decrease fuel efficiency and performance, and result in damage to the engine.

Auto Choke Troubleshooting (if equipped)

If engine is equipped with auto choke, identify design and follow appropriate troubleshooting procedure.

NOTE: Procedures may be easier to perform with engine cover removed. Refer to Disassembly/Inspection and Service and Reassembly procedure.

Auto Choke Components - Vacuum/Diaphragm Design

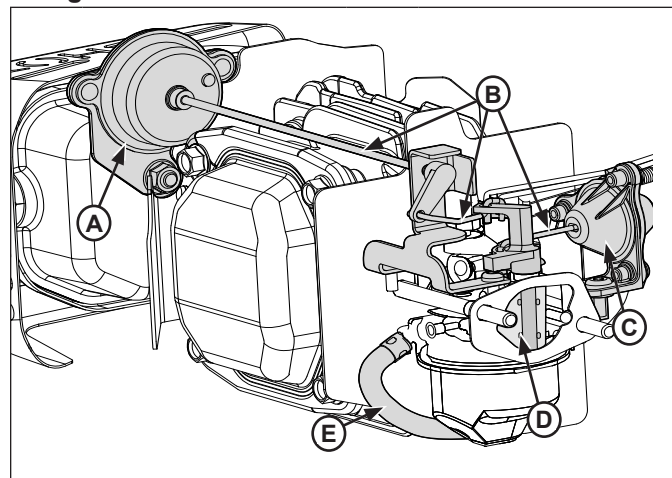

A	Bimetallic Spring Housing	B	Linkage
C	Diaphragm Assembly	D	Choke Plate
E	Vacuum Hose		

A bimetallic spring reacts to muffler heat and moves linkage that opens or closes choke. A diaphragm that operates from intake manifold vacuum assists spring system. These two elements work together to operate a smooth choke system that facilitates easy reliable starting.

Use following procedures to troubleshoot vacuum/diaphragm design auto choke system and its components. These procedures are to be performed on a cold engine.

Fuel System

Cover, Element, and Breather Cover

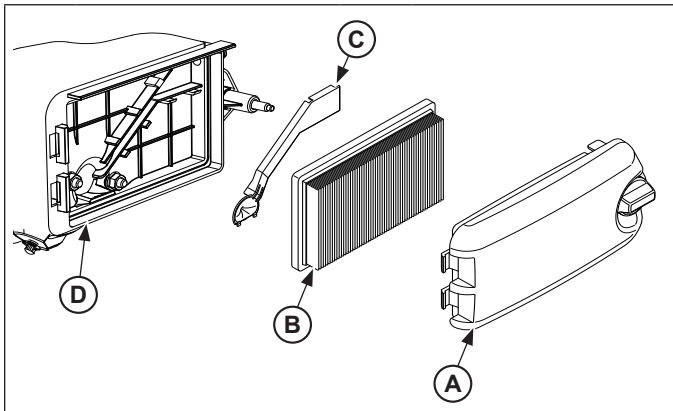

A	Air Cleaner Cover	B	Element
C	Breather Cover	D	Air Cleaner Base

1. Remove air cleaner cover, air cleaner, and breather cover from air cleaner base.
2. Check choke linkage for binding or debris build up. Gently actuate linkage and observe that choke plate has full range of movement (open and close).
3. Remove vacuum hose from carburetor vacuum fitting. Attach a vacuum gauge or manometer to carburetor vacuum fitting. Run engine while holding choke plate open. Gauge should indicate a vacuum with a minimum of 15" of water. If reading is correct, check again for binding of restricted linkage.
4. If vacuum indicated is less than 15" of water, problem is not an auto choke issue.

Diaphragm Assembly and Hose

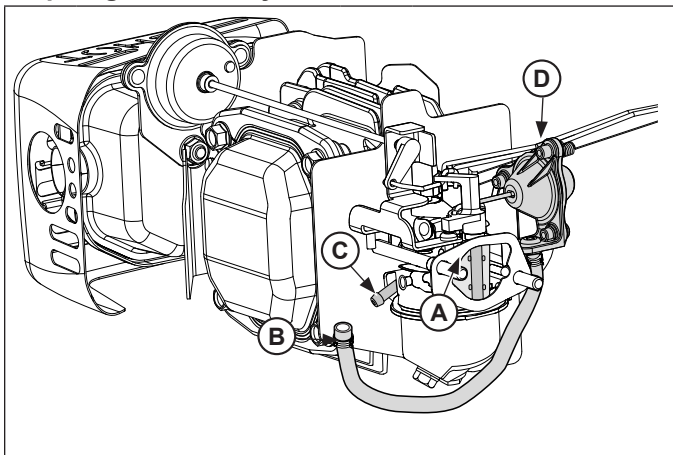

A	Choke Plate	B	Vacuum Hose
C	Vacuum Fitting	D	Diaphragm Assembly

5. Note position of choke plate. Attach a vacuum pump to vacuum hose. Choke plate should open 1/2 to 3/4 under vacuum and with a minimum of 15" of water. If diaphragm assembly is unable to open choke plate, check hose for cracks, leaks, or restrictions. If necessary replace vacuum hose. If hose is in working condition and choke plate fails to open with specified vacuum, or diaphragm fails to hold choke plate open for a minimum of 3 seconds, replace diaphragm assembly.
6. Attach vacuum hose to carburetor vacuum fitting.
7. Start engine. Upon start up choke plate should be 1/2 to 3/4 open. Choke plate should gradually change to full open position after 2 to 2-1/2 minutes of running. This action is performed by bimetallic spring assembly being heated. If choke plate fails to open, recheck linkage for binding. If necessary replace bimetallic spring assembly.

NOTE: Inspect to ensure choke linkage is not binding.

Choke Plate and Bimetallic Spring Housing

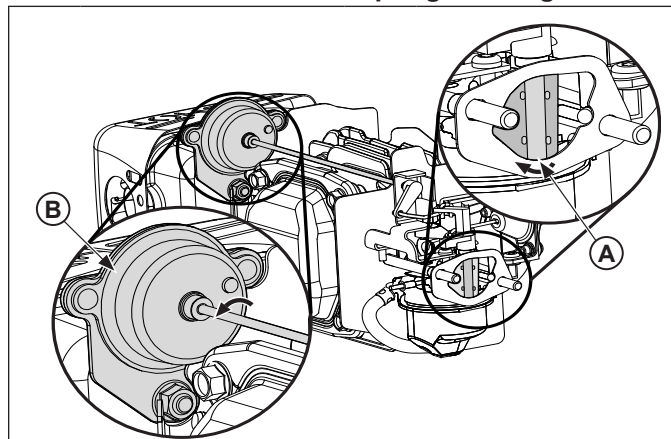

A	Choke Plate	B	Bimetallic Spring Assembly
----------	-------------	----------	----------------------------

Auto Choke Components - Link Design

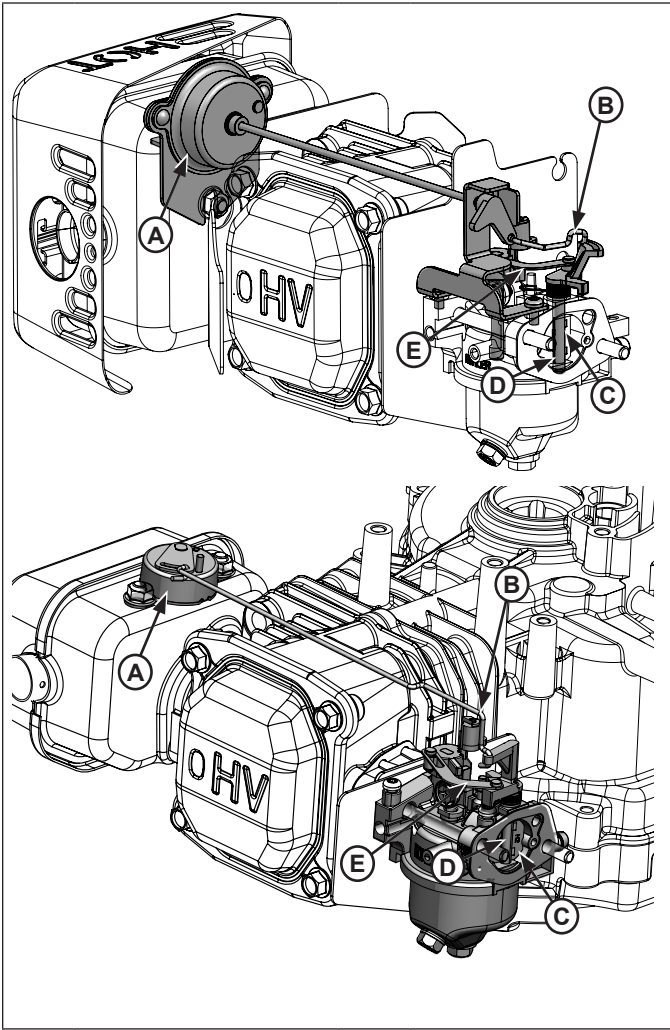

When engine is cold, spring around base of choke shaft holds choke closed for starting. When engine starts, governor closes throttle from wide open to set governor speed. As throttle closes, link between throttle and choke operates choke to a slightly open position. After engine warms up, bimetallic spring overcomes choke shaft spring force and holds choke completely open.

Use these steps to check function of link design auto choke.

1. Remove air cleaner cover and element.
2. Choke plate should be fully close when engine is cold.
3. There should be light spring tension holding choke closed.
4. There should not be any binding when choke shaft assembly is rotated, which could cause choke to remain partially open.
5. When engine is started, choke plate should be 1/3 open. Choke plate should start to open and be completely open within 2 to 3 minutes at room temperature.
6. Reinstall air cleaner element and secure cover.

A	Bimetallic Spring Housing	B	Wire Choke Linkage
C	Choke Plate	D	Choke Lever
E	Choke Link		

Governor System

GOVERNOR

Governor Components

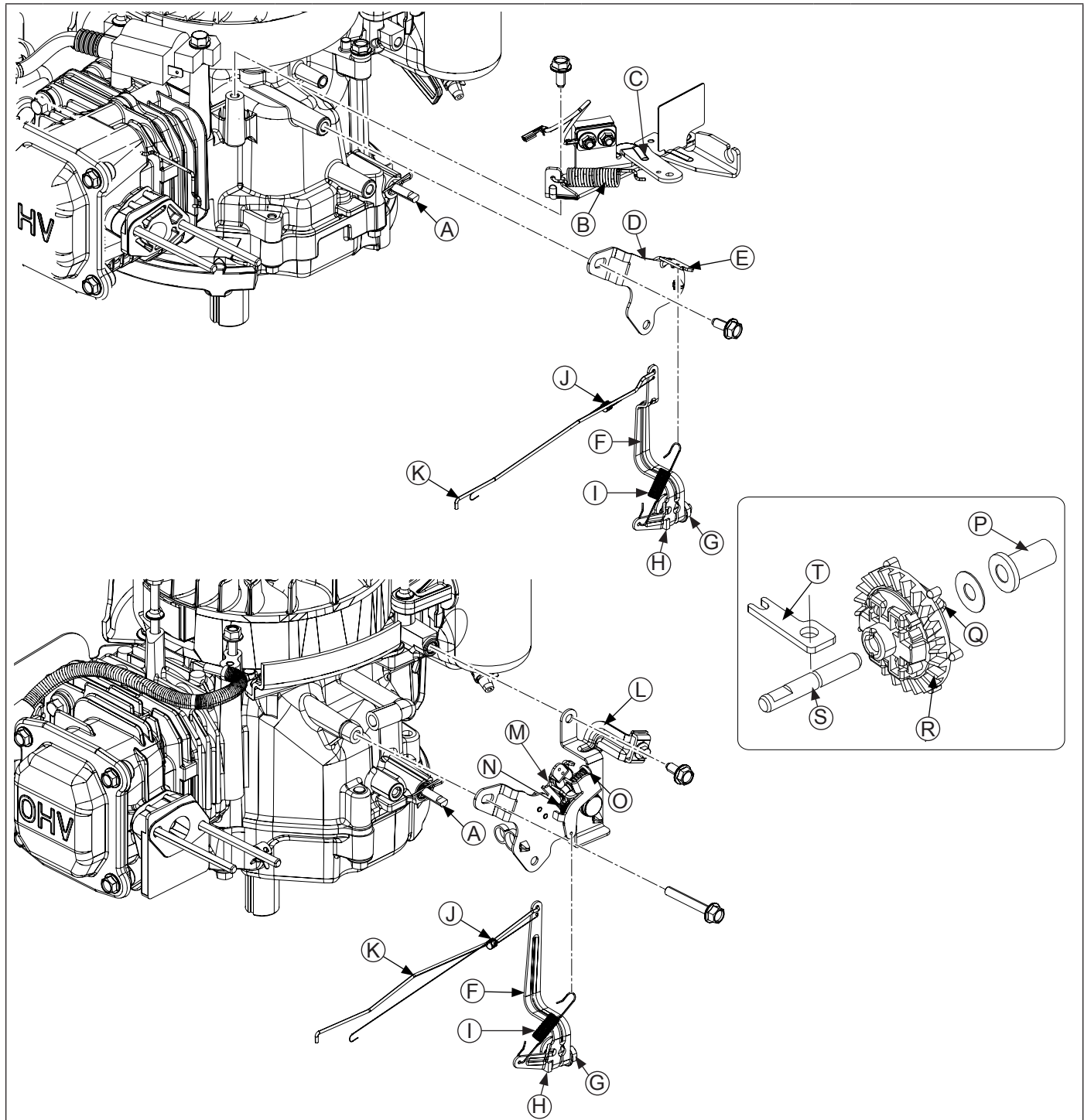

A	Governor Cross Shaft	B	Brake Spring (if equipped)	C	Brake Lever (if equipped)	D	Fixed Speed Control Bracket
E	High Speed Adjustment Tab	F	Governor Lever	G	Nut	H	Screw
I	Governor Spring	J	Linkage Spring	K	Linkage	L	Variable Speed Control Lever

Governor System

M	Intermediate Control Lever	N	Control Spring	O	High Speed Adjusting Screw	P	Regulating Pin
Q	Flyweight(s)	R	Governor Gear	S	Governor Gear Shaft	T	Governor Shaft Retainer

Governed speed setting is determined by position of throttle control. It can be variable or constant, depending on engine application.

Governor is designed to hold engine speed constant under changing load conditions. Most engines are equipped with a centrifugal flyweight mechanical governor. Governor gear/flyweight mechanism of mechanical governor is mounted inside oil pan and is driven off gear on camshaft.

This governor design works as follows:

- Centrifugal force acting on rotating governor gear assembly causes flyweights to move outward as speed increases. Governor spring tension moves them inward as speed decreases.
- As flyweights move outward, they cause regulating pin to move outward.
- Regulating pin contacts tab on cross shaft causing shaft to rotate.
- One end of cross shaft protrudes through crankcase. Rotating action of cross shaft is transmitted to throttle lever of carburetor through external throttle linkage.
- When engine is at rest, and throttle is in fast position, tension of governor spring holds throttle plate open. When engine is operating, governor gear assembly is rotating. Force applied by regulating pin against cross shaft tends to close throttle plate. Governor spring tension and force applied by regulating pin balance each other during operation, to maintain engine speed.
- When load is applied and engine speed and governor gear speed decreases, governor spring tension moves governor arm to open throttle plate wider. This allows more fuel into engine, increasing engine speed. As speed reaches governed setting, governor spring tension and force applied by regulating pin will again offset each other to hold a steady engine speed.

Initial Governor Adjustment

Make this initial adjustment whenever governor arm is loosened or removed from cross shaft. To ensure proper adjustment, make sure throttle linkage is connected to both governor arm and throttle lever on carburetor.

1. Loosen nut holding governor lever to cross shaft.
2. Move governor lever away from carburetor (wide open throttle) and hold in this position. Do not apply excess force that may flex or distort throttle link.
3. Grasp cross shaft with a pliers and turn shaft clockwise as far as it will go, hold and tighten nut. Then torque nut to 9.5 N·m (84 in. lb.).

Lubrication System

These engines use a splash lubrication system, supplying necessary lubrication to crankshaft, camshaft, connecting rod, and valve train components.

Lubrication Components

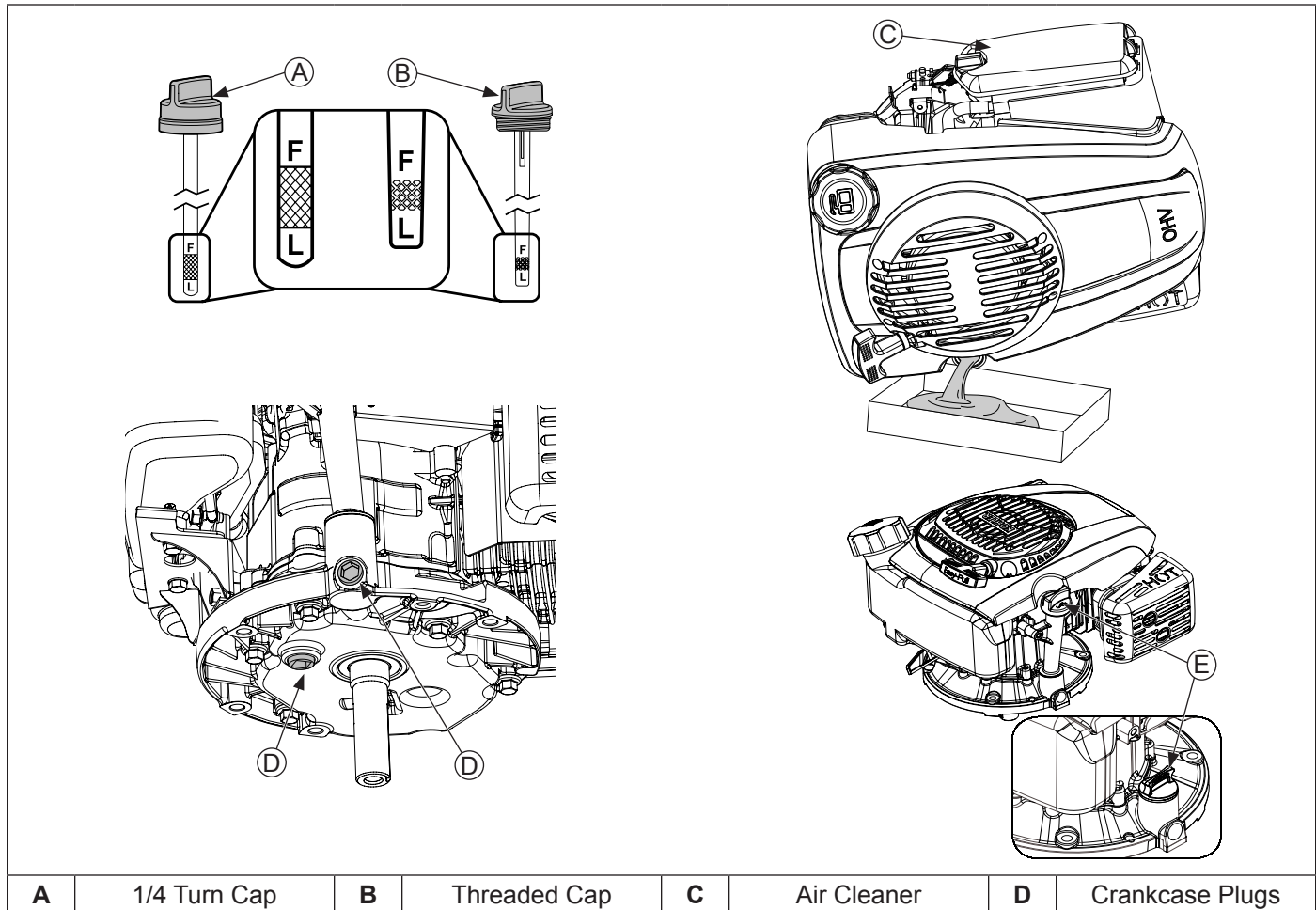

OIL RECOMMENDATIONS

Refer to Maintenance.

CHECK OIL LEVEL

NOTE: To prevent extensive engine wear or damage, never run engine with oil level below or above operating range indicator on dipstick.

Ensure engine is cool and level. Clean oil fill cap/dipstick areas of any debris.

1. Remove dipstick; wipe oil off.
 - a. 1/4 turn cap: reinsert dipstick into tube; press completely down and turn 1/4 turn.
 - or
 - b. Threaded cap: reinsert dipstick into tube; rest cap on tube, do not thread cap onto tube.
2. Remove dipstick; check oil level. Level should be at top of indicator on dipstick.
3. If oil is low on indicator, add oil up to top of indicator mark.
4. Reinstall and secure dipstick.

CHANGE OIL

Change oil while engine is warm.

Dipstick tube

1. Clean area around oil fill cap/dipstick.
2. Remove oil fill cap/dipstick. Tilt engine on its side with air cleaner facing up. Drain oil into appropriate container.
3. After crankcase is drained completely, tilt engine upright.
4. Fill crankcase with new oil. Level should be at top of indicator on dipstick.
5. Reinstall oil fill cap/dipstick and tighten securely.
6. Dispose of used oil in accordance with local ordinances.

Crankcase plug

1. Disable engine by disconnecting spark plug.
2. Clean area around oil fill cap/dipstick. Remove oil fill cap/dipstick.
3. Remove crankcase plug on bottom of engine; drain oil into appropriate container.
4. Apply thread sealant around three full threads of drain plug; reinstall drain plug. Torque drain plug to 13.6 N·m (120 in. lb.).
5. Fill crankcase with new oil. Level should be at top of indicator on dipstick.
6. Reinstall oil fill cap/dipstick and tighten securely.
7. Dispose of used oil in accordance with local ordinances.

Electrical System

SPARK PLUGS



CAUTION

Electrical Shock can cause injury.
Do not touch wires while engine is running.

Spark Plug Component and Details

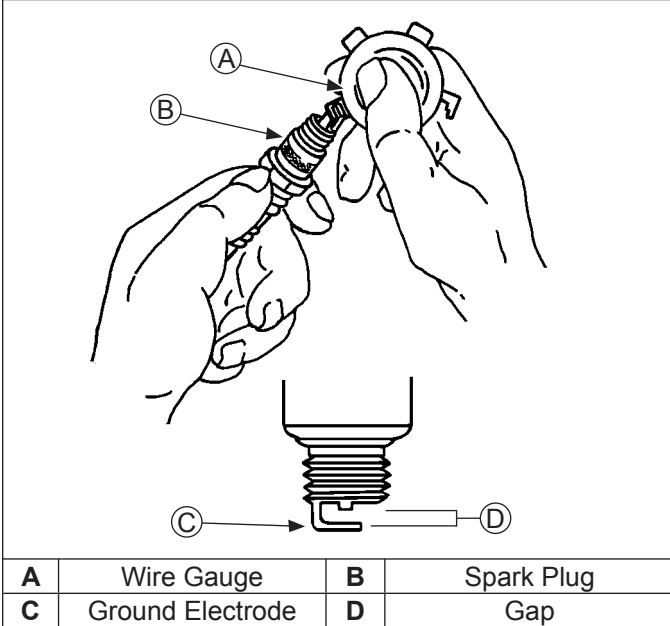

NOTE: Do not clean spark plug in a machine using abrasive grit. Some grit could remain in spark plug and enter engine causing extensive wear and damage.

Engine misfire or starting problems are often caused by a spark plug that has improper gap or is in poor condition.

Engine is equipped with following spark plugs:

Gap	0.76 mm (0.030 in.)
Thread Size	12 mm
Reach	19.1 mm (3/4 in.)
Hex Size	18 mm (3/4 in.)

Refer to Maintenance for Repairs/Service Parts.

Service

Clean out spark plug recess. Remove plug and replace.

1. Check gap using wire feeler gauge. Adjust gap to 0.76 mm (0.030 in.).
2. Install plug into cylinder head.
3. Torque plug to 27 N·m (20 ft. lb.).

Inspection

Inspect each spark plug as it is removed from cylinder head. Deposits on tip are an indication of general condition of piston rings, valves, and carburetor.

Normal and fouled plugs are shown in following photos:

Normal

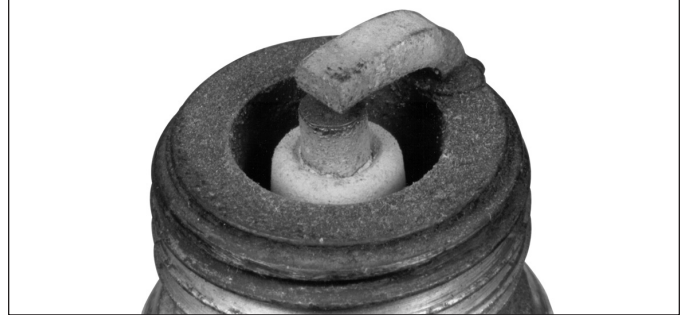

Plug taken from an engine operating under normal conditions will have light tan or gray colored deposits. If center electrode is not worn, plug can be set to proper gap and reused.

Worn



On a worn plug, center electrode will be rounded and gap will be greater than specified gap. Replace a worn spark plug immediately.

Wet Fouled



A wet plug is caused by excess fuel or oil in combustion chamber. Excess fuel could be caused by a restricted air cleaner, a carburetor problem, or operating engine with too much choke. Oil in combustion chamber is usually caused by a restricted air cleaner, a breather problem, worn piston rings, or valve guides.

Carbon Fouled



Soft, sooty, black deposits indicate incomplete combustion caused by a restricted air cleaner, over rich carburetion, weak ignition, or poor compression.

Overheated



Chalky, white deposits indicate very high combustion temperatures. This condition is usually accompanied by excessive gap erosion. Lean carburetor settings, an intake air leak, or incorrect spark timing are normal causes for high combustion temperatures.

BATTERY

A 12 volt battery (OEM supplied) is used for cranking electric start engines. Actual cold cranking requirement depends on engine size, application, and starting temperatures. Cranking requirements increase as temperatures decrease and battery capacity shrinks. Refer to equipment's operating instructions for specific battery requirements.

If battery charge is insufficient to turn over engine, recharge battery.

Battery Maintenance

Regular maintenance is necessary to prolong battery life.

Battery Test

To test battery, follow manufacturer's instructions.

ELECTRONIC IGNITION SYSTEM

Inductive Discharge Ignition System

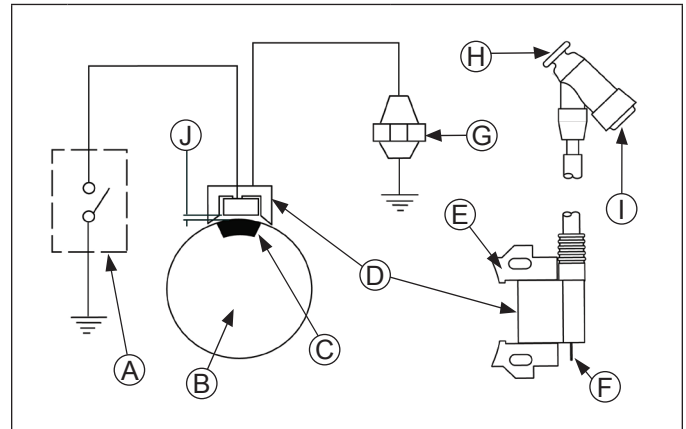

A	Stop/Kill Switch	B	Flywheel
C	Magnet	D	Ignition Module
E	Lamination	F	Kill Terminal
G	Spark Plug	H	Spark Plug Boot
I	Spark Plug Terminal	J	Air Gap 0.254 mm (0.010 in.)

These engines are equipped with a dependable magneto breakerless ignition. In such a system, electrical energy is generated by cutting of magnetic flux lines generated from ignition magnet on engine flywheel via prescribed air gap as it passes ignition module. This energy is transferred through ignition module laminations and is then converted in module electronics and stored in module primary coil, as a current. Stored energy is transferred at correct moment by triggering a semiconductor switch inside module. Electrical break by switch initiates energy transfer by causing collapse of magnetic field at coil primary. This includes a voltage at coil primary that is amplified via transformer action at coil secondary. Amplitude of voltage at coil secondary is sufficient to jump gap at spark plug, igniting fuel air mixture in gap and initiating combustion. Note that by design, these modules only will provide proper function if mounted in correct orientation.

This ignition system is designed to be trouble free for life of engine. Other than periodically checking/replacing spark plugs, no maintenance or timing adjustments are necessary or possible. Mechanical systems do occasionally fail or break down. Refer to Troubleshooting to determine root of a reported problem.

Reported ignition problems are most often due to poor connections. Before beginning test procedure, check all external wiring. Be certain all ignition-related wires are connected, including spark plug leads. Be certain all terminal connections fit snugly. Make sure ignition is in run position.

Electrical System

Electronic Ignition System Tests (Retractable Start)

Test Ignition System

Remove spark plug. Check condition of spark plug. Make sure gap is set to 0.76 mm (0.030 in.). Install spark plug and torque to 27 N·m (20 ft. lb.).

Condition	Possible Cause	Conclusion
Spark plug is not receiving ignition pulse.	Spark Plug	Check gap and adjust if necessary; reinstall plug.
Spark plug in bad condition.	Spark Plug	Replace plug, set gap, and install.

Test for Spark

NOTE: To maintain engine speeds obtained during cranking, do not remove spark plug.

Test for spark with spark plug tester.

1. Disconnect spark plug lead and connect to post terminal of tester. Connect clip to ground, not to spark plug.
2. Place engine ignition switch in RUN position to initiate test.
3. Pull retractable starter to a minimum of 350-450 RPM and check for spark. Visible and/or audible sparks should be produced.

Condition	Possible Cause	Conclusion
Visible and/or audible sparks are produced.	Ignition Module	Ignition module is OK.
Visible and/or audible sparks are not produced.	Ignition Module or Wiring and Connections	Make sure ignition switch, kill switch or key switch is in RUN position. Check all safety and operator presence control switches (for example: flywheel brake kill switch) and other components, including wiring and connections for accidental grounding. If components, wiring, including terminals are all verified OK, test ignition module.

Test Ignition Module

1. Remove retractable starter and engine cover; refer to Disassembly/Inspection and Service. Disconnect kill lead from terminal on ignition module.
2. Reinstall retractable starter and engine cover. Pull retractable starter to a minimum of 350-450 RPM and check for spark.

Condition	Possible Cause	Conclusion
Visible and/or audible sparks are produced.	Kill/Stop Engine Wiring and Connections	Problem is elsewhere in system/wiring.
Visible and/or audible sparks are not produced.	Ignition Module	Test ignition module (step 3).

3. Set an ohmmeter to Rx1K or Rx10K scale and zero.
Connect one ohmmeter lead to module kill lead tab and connect other lead into spark plug cap. Resistance should be 5-15 K ohms. If resistance is other than specified, replace ignition module.

Electronic Ignition System Tests (Electric Start)

1. Disconnect cap from spark plug and attach it to terminal end of spark tester. Attach tester spring clip to a good ground, not to spark plug. With ignition switch ON, crank engine to a minimum of 350-450 RPM while observing firing tip of tester.

Condition	Conclusion
Visible and/or audible sparks are produced.	Ignition system is good. Install a new spark plug and try to start engine. If it still will not start, check other possible causes (fuel, compression, etc.).
Visible and/or audible sparks are not produced.	Test kill lead circuit (step 2).

2. Remove retractable starter and engine cover; refer to Disassembly/Inspection and Service. Disconnect kill lead from ignition module. Repeat spark test (step 1).

Condition	Conclusion
Spark is now present.	Check for a shorted lead in kill circuit or a faulty switch (step 4).
Still no spark.	Test ignition module (step 3).

3. Set an ohmmeter to Rx1K or Rx10K scale and zero. Connect one ohmmeter lead to module kill lead tab and connect other lead into spark plug cap. Resistance should be 5-15 K ohms. If resistance is not in this range, replace ignition module.
4. Test ignition/key switch following equipment manufacturer's instructions. Refer to equipment manufacturer's manual.

NOTE: Observe following guidelines to avoid damage to electrical system and components:

- Make sure battery polarity is correct. A negative (-) ground system is used.
- Make sure all ground connections are secure and in good condition.
- Disconnect both battery cables before doing electrical welding on equipment powered by engine. Also, disconnect other electrical accessories in common ground with engine.
- Prevent stator (AC) lead (if equipped) from touching or shorting while engine is running. This could damage stator.

Wiring Diagram-Electric Start with Retractable Starter, No Charging System

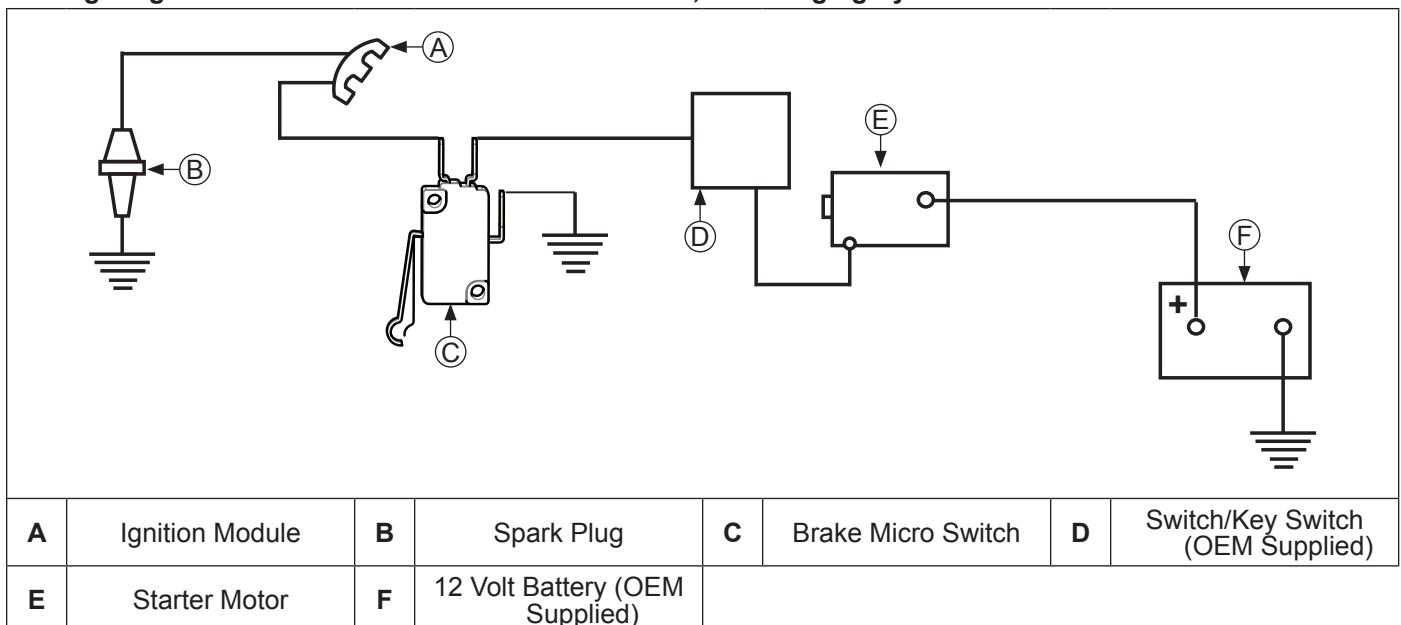

Electrical System

Rectified Only (non-regulated) Systems (if equipped)

Some engines are equipped with a rectified (in-line diode) only, non-regulated 1 amp charging system. Diode (rectifier) is a sealed in-line wiring jumper between stator and a battery (B+) connection (OEM location). Jumper features male/female bullet connectors and can only be installed one way. Diode (rectifier) converts AC voltage coming from stator to DC voltage only.

Wiring Diagram-1 Amp Charging System, Rectified Only

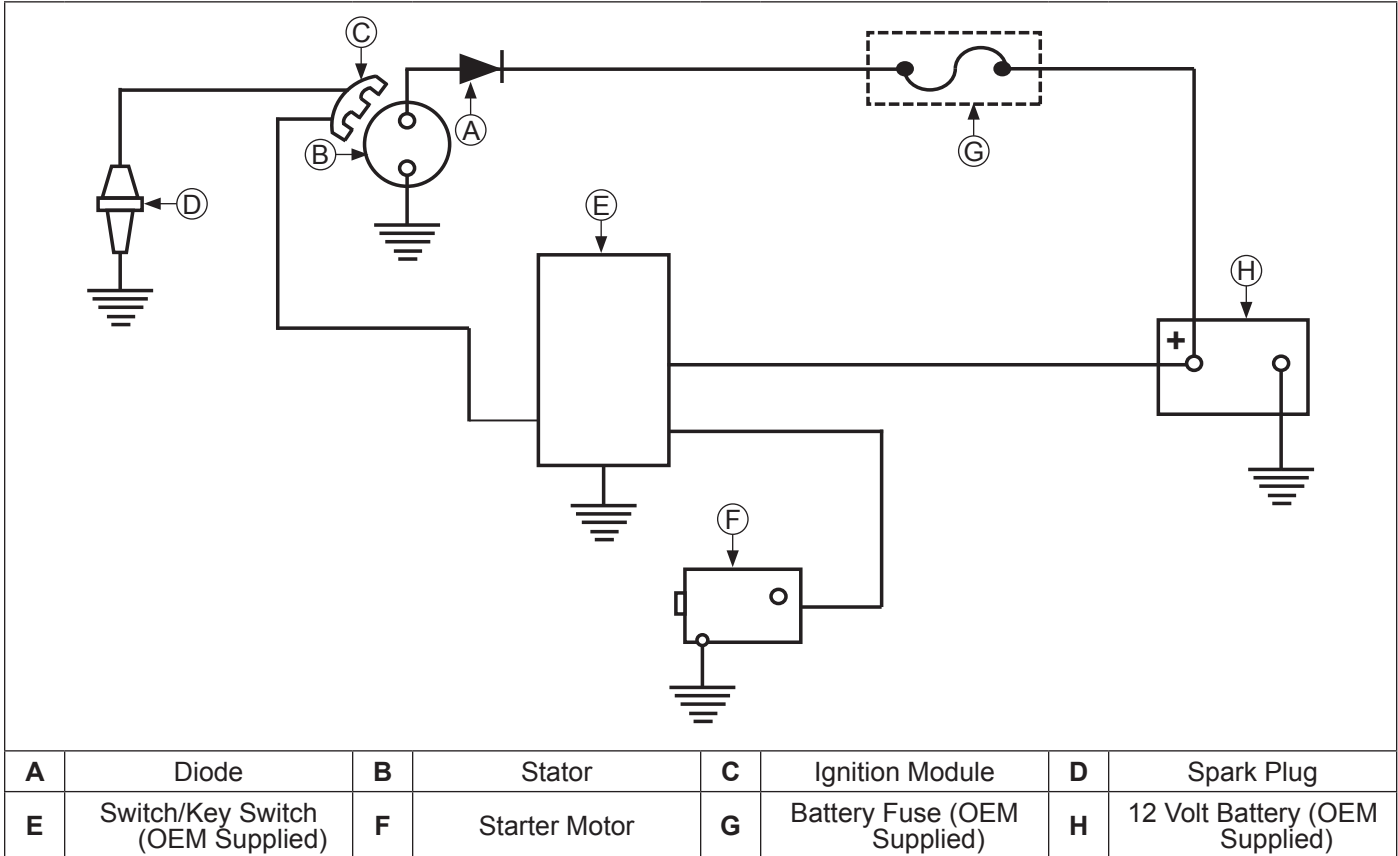

1 Amp Battery Charging System

NOTE: Zero ohmmeters on each scale to ensure accurate readings. Voltage tests should be made with engine running at high speed - no load. Battery must be fully charged. If low, recharge or replace battery as necessary.

To test charging system for no charge to battery:

1. Connect DC voltmeter red positive (+) lead to positive (+) terminal of battery. Connect voltmeter black negative (-) lead to negative (-) terminal of battery. Observe battery voltage. Run engine at high speed and read voltage on voltmeter.

If running battery voltage is higher than non running observed voltage, charging system is functioning.

Condition	Conclusion
Battery voltage increases when engine is running.	Charging system is OK.
Battery voltage does not increase when engine is running.	Test diode and stator (steps 2, 3, and 4).

2. Disconnect diode (rectifier) from harness. Perform continuity test from male bullet connector to female connector; record results. Switch test leads to opposite connectors and repeat continuity test.

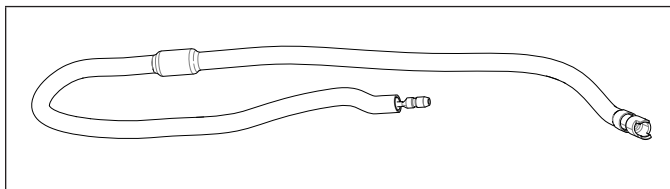

Condition	Conclusion
Continuity is measured in one direction only.	Diode is OK. Test stator (steps 3 and 4).
If open in both tests or closed in both tests.	Replace diode.

3. Connect an AC voltmeter to stator lead connect other lead to crankcase ground. With engine running at high speed, measure AC output from stator.

Condition	Conclusion
Voltage is measured.	Stator is OK.
Voltage is not measured.	Stator is probably faulty and should be replaced. Test stator further using an ohmmeter (step 4).

4. With engine stopped, measure resistance from stator lead to ground using an ohmmeter.

Condition	Conclusion
Resistance is infinity ohms (no continuity).	Stator is OK (not shorted to ground).
Resistance (or continuity) is measured.	Stator lead is shorted to ground; replace stator.

Starter System

NOTE: Do not crank engine continuously for more than 10 seconds. Allow a 60 second cool down period between starting attempts. Failure to follow these guidelines can burn out starter motor.

NOTE: If engine develops sufficient speed to disengage starter but does not keep running (a false start), engine rotation must be allowed to come to a complete stop before attempting to restart engine. If starter is engaged while flywheel is rotating, starter pinion and flywheel ring gear may clash and damage starter.

NOTE: If starter does not crank engine, shut off starter immediately. Do not make further attempts to start engine until condition is corrected.

NOTE: Do not drop starter or strike starter frame. Doing so can damage starter.

Engines in this series use inertia drive electric starters and/or retractable starters. Inertia drive electric starters are not serviceable.

Some HD electric starters use brake switch for an interlock (on ground). When bail is held down, switch in brake assembly completes circuit of ground for starter. If there is a no crank situation, cause could be brake assembly, battery, key switch, wiring harness, fuse (if equipped), or starter itself.

Troubleshooting-Starting Difficulties

Condition	Possible Cause	Conclusion
Starter does not energize.	Battery	Check battery state of charge. If low, recharge or replace battery as necessary.
	Wiring	Check fuse condition (if equipped). Clean corroded connections and tighten loose connections. Replace wires in poor condition and with frayed or broken insulation.
	Starter Switch or Brake Assembly	Check switch operation. Replace faulty components.
Starter energizes but turns slowly.	Battery	Check battery state of charge. If low, recharge or replace battery as necessary.
	Wiring	Check for corroded connections, poor ground connection.
	Self-propelled Drive Unit (if equipped) or Engine	Make sure drive unit is disengaged or in neutral. This is especially important on equipment with a self-propelled drive unit. Drive unit must be in neutral to prevent resistance which could keep engine from starting. Check for seized engine components such as bearings, connecting rod, and piston.

Electric Starting System Tests (Without Brake Assembly)

NOTE: Battery must be fully charged. If low, recharge or replace battery as necessary.

1. Test battery on unit.
 - a. Connect a DC voltmeter across battery terminals and read battery voltage (key switch OFF).
 - b. Turn key switch to start position and read battery voltage again. Turn switch OFF.

Condition	Conclusion
Voltage less than 12 volts.	Charge or replace battery.
Battery voltage should not fall below 9 volts during cranking.	If it does, battery may be faulty or there may be a short in starting circuit.

2. Use a known, good, fully-charged battery and jumper cables to test starter motor. Be sure drive unit is in neutral and blade is off (if equipped with a blade brake clutch assembly (BBC)).

Disconnect starter wire from application. Connect one end of positive (+) jumper cable to bullet terminal of red starter wire and connect other end to positive (+) terminal of battery.

Connect one end of negative (-) jumper cable to negative terminal of battery. Touch other end of negative (-) jumper cable to a bare surface on crankcase or to starter housing.

Condition	Conclusion
Starter engages and begins to crank.	Key switch is faulty, or there is a wiring problem to/from key switch. Check wiring and test key switch circuits.
Starter does not crank.	Replace starter.

Electric Starting System Tests (With Brake Assembly)

NOTE: Battery must be fully charged. If low, recharge or replace battery as necessary.

1. Test battery on unit.
 - a. Connect a DC voltmeter across battery terminals and read battery voltage (key switch OFF).
 - b. Place handlebar bail lever in run position, turn key switch to start position and read battery voltage again. Turn switch OFF.

Condition	Conclusion
Voltage less than 12 volts.	Charge or replace battery.
Battery voltage should not fall below 9 volts during cranking.	If it does, battery may be faulty or there may be a short in starting circuit.

2. Use a known, good, fully-charged battery and jumper cables to test starter motor. Be sure drive unit is in neutral, blade is off (if equipped with a blade brake clutch (BBC) assembly), and/or handlebar bail lever is in run position.

Disconnect starter wire from application. Connect one end of positive (+) jumper cable to bullet terminal of red starter wire and connect other end to positive (+) terminal of battery.

Connect one end of negative (-) jumper cable to negative terminal of battery. Touch other end of negative (-) jumper cable to a bare surface on crankcase or to starter housing.

Condition	Conclusion
Starter engages and begins to crank.	Key switch or brake micro switch is faulty, or there is a wiring problem to/from key switch or brake micro switch. Check wiring and test key switch circuits and ground circuit for brake micro switch and starter.
Starter does not crank.	Replace starter.

Wiring Diagram-Electric Start with Retractable Starter and Brake Assembly

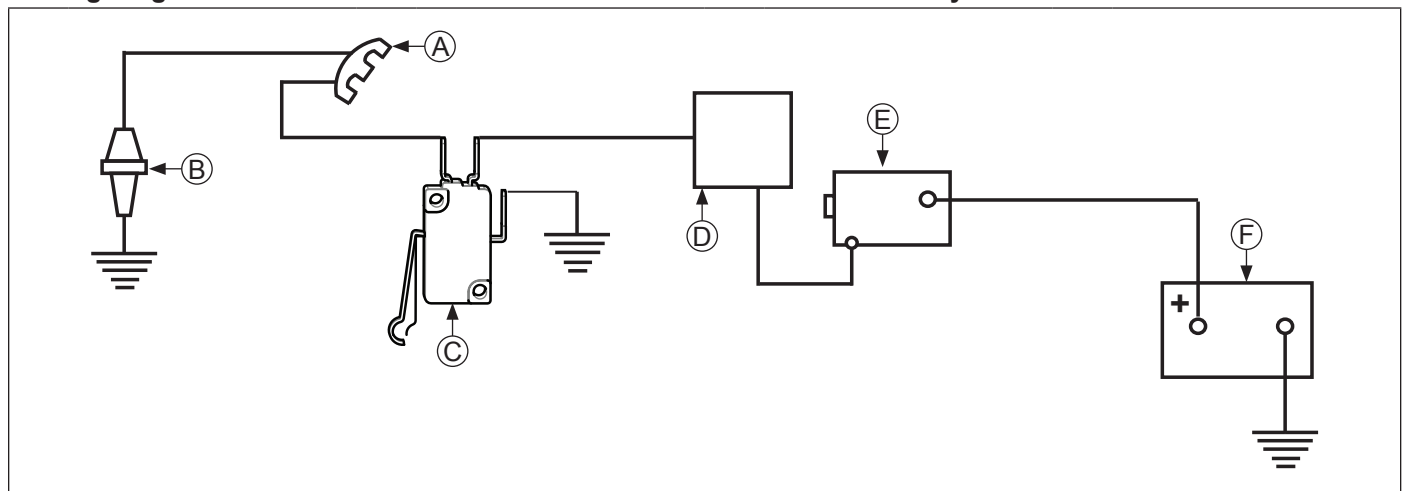

A	Ignition Module	B	Spark Plug	C	Brake Micro Switch	D	Switch/Key Switch (OEM Supplied)
E	Starter Motor	F	12 Volt Battery (OEM Supplied)				

Starter System

RETRACTABLE STARTERS

	⚠ WARNING
	<p>Uncoiling Spring can cause severe injury. Wear safety goggles or face protection when servicing retractable starter.</p>

Retractable starters contain a powerful, recoil spring that is under tension. Always wear safety goggles when servicing retractable starters and carefully follow instructions in Retractable Starter for relieving spring tension.

Retractable Starter Components

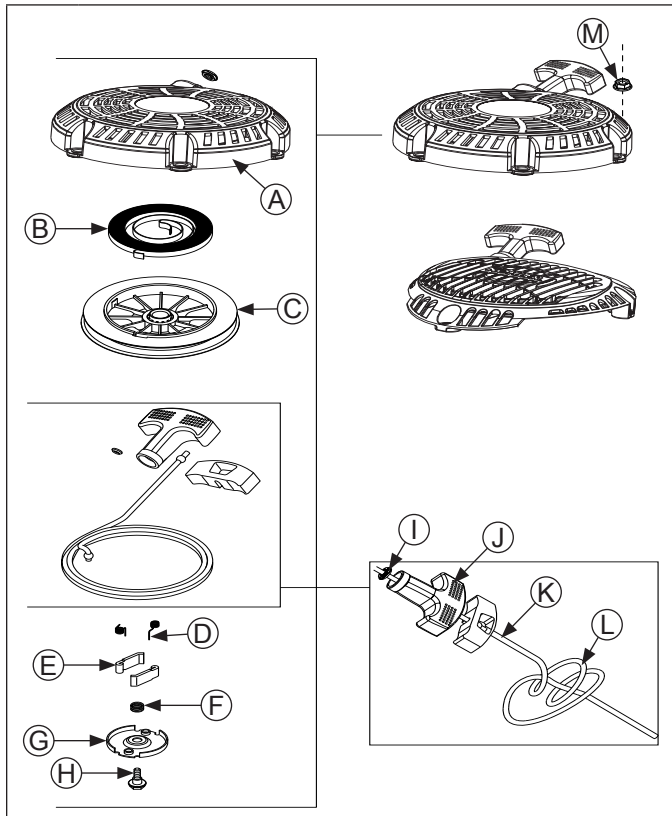

A	Housing	B	Recoil Spring
C	Pulley	D	Drive Pawl Springs
E	Drive Pawl (Dogs)	F	Pulley Spring
G	Drive Plate	H	Center Screw
I	Grommet	J	Starter Handle
K	Starter Rope	L	Double Left-Hand Knot
M	Hex Flange Nut		

Remove Starter

NOTE: Whenever possible, an impact wrench should be used to loosen nuts securing retractable starter.

1. Remove nuts securing starter to blower housing.
2. Remove starter assembly.

Rope Replacement

NOTE: Do not allow pulley/spring to unwind. Enlist aid of a helper if necessary.

Rope can be replaced without complete starter disassembly.

1. Remove starter assembly from engine.
2. Pull rope out approximately 12 in. and tie a temporary (slip) knot in it to keep it from retracting into starter.
3. Pull knot end out of handle, untie knot, and slide handle off.
4. Hold pulley firmly and untie slipknot. Allow pulley to rotate slowly as spring tension is released.
5. When all spring tension on starter pulley is released, remove rope from pulley.
6. Tie a double left-hand knot in one end of new rope.
7. Rotate pulley counterclockwise to pre-tension spring (approximately 4 full turns of pulley).
8. Continue rotating pulley counterclockwise until rope hole in pulley is aligned with rope guide bushing of starter housing.
9. Insert unknotted end of new rope through rope hole in starter pulley and rope guide bushing of housing.
10. Tie a slipknot approximately 12 in. from free end of rope. Hold pulley firmly and allow it to rotate slowly until slipknot reaches guide bushing of housing.
11. Insert starter rope through starter handle and tie a double, left-hand knot at end of starter rope. Insert knot into hole in handle.
12. Untie slip knot and pull on starter handle until starter rope is fully extended. Slowly retract starter rope into starter assembly. If recoil spring is properly tensioned, starter rope will retract fully and starter handle will stop against starter housing.

Pawls (dogs) Replacement

1. Install a clamp to hold pulley in starter housing and prevent it from rotating.
2. Unscrew center screw and lift off drive plate.
3. Note positions of pawls and pawl springs before removing. Remove parts from pulley.
4. Install pawl springs and pawls into pawl slots of pulley. All parts must be dry.
5. Position drive plate over pawls, aligning actuating slots in place with raised sections on each drive pawl. Torque center screw to 5-6 N·m (44-54 in. lb.).
6. Remove clamp and pull starter rope out part way to check operation of pawls.

Install Starter

1. Place starter onto studs protruding from blower housing. Start nuts onto studs, but do not tighten.
2. Pull starter handle out until pawls engage in drive cup. Hold handle in this position and torque nuts to 8 N·m (71 in. lb.).

Disassembly/Inspection and Service

	⚠ WARNING	Before working on engine or equipment, disable engine as follows: 1) Disconnect spark plug lead(s). 2) Disconnect negative (-) battery cable from battery.
	Accidental Starts can cause severe injury or death. Disconnect and ground spark plug lead(s) before servicing.	

External Engine Components

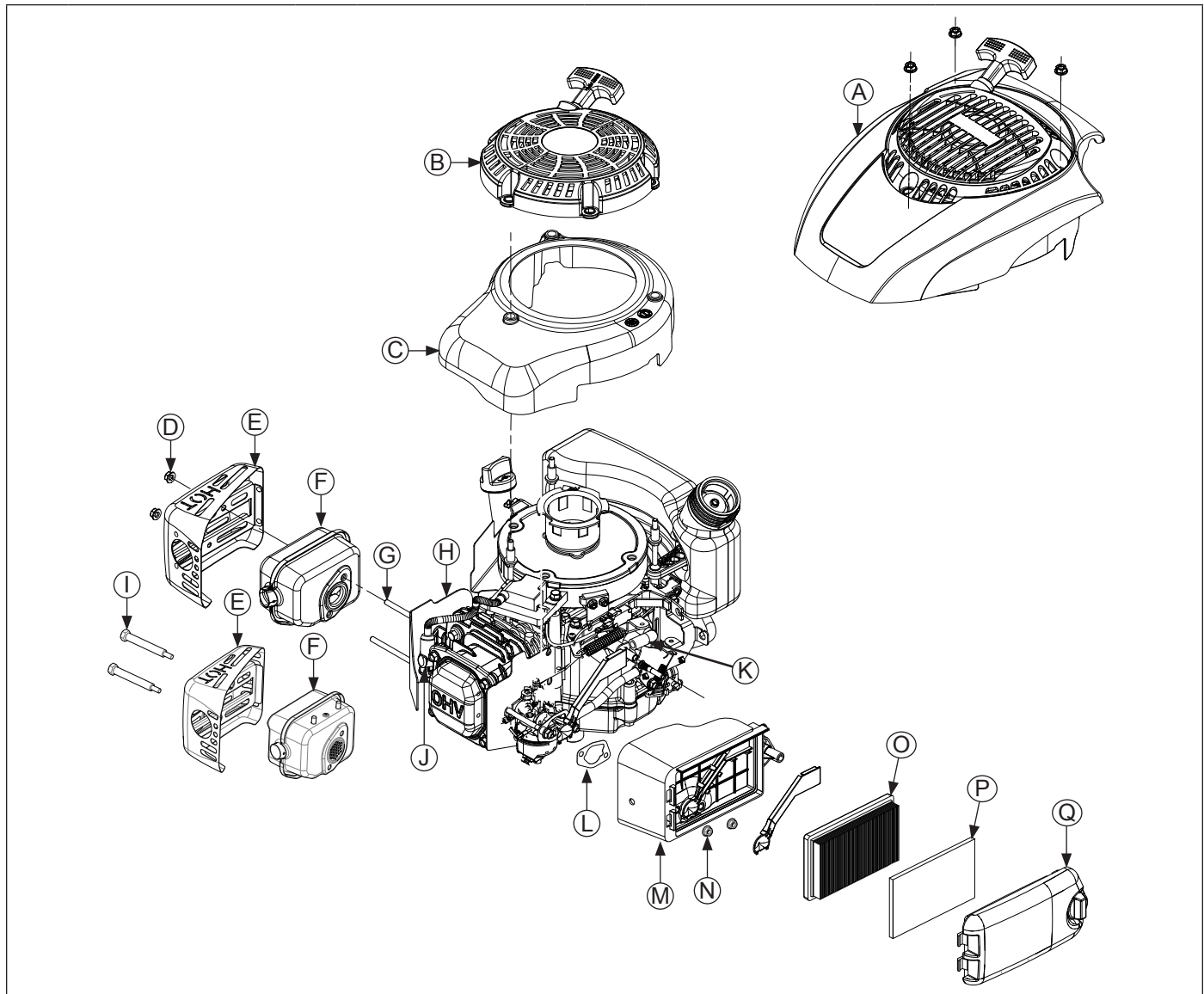

A	Engine Cover and Retractable Starter	B	Retractable Starter	C	Blower Housing	D	Lock Nut
E	Muffler Guard	F	Muffler	G	Exhaust Stud	H	Muffler Gasket (Heat Deflector)
I	Shoulder Screw	J	Spark Plug Lead	K	Breather Hose	L	Air Cleaner Base Gasket
M	Air Cleaner Base	N	Nut	O	Paper Element	P	Precleaner
Q	Air Cleaner Cover						

Disassembly/Inspection and Service

Clean all parts thoroughly as engine is disassembled. Only clean parts can be accurately inspected and gauged for wear or damage. There are many commercially available cleaners that will quickly remove grease, oil, and grime from engine parts. When such a cleaner is used, follow manufacturer's instructions and safety precautions carefully.

Make sure all traces of cleaner are removed before engine is reassembled and placed into operation. Even small amounts of these cleaners can quickly break down lubricating properties of engine oil.

Empty Fuel Tank

1. Ensure fuel tank is empty by running engine until it stops, and is completely out of fuel.
2. Remove gas cap.

Disconnect Spark Plug

NOTE: Pull on boot only, to prevent damage to spark plug lead.

Disconnect lead from spark plug.

Drain Oil From Crankcase

Drain Oil from Dipstick Tube

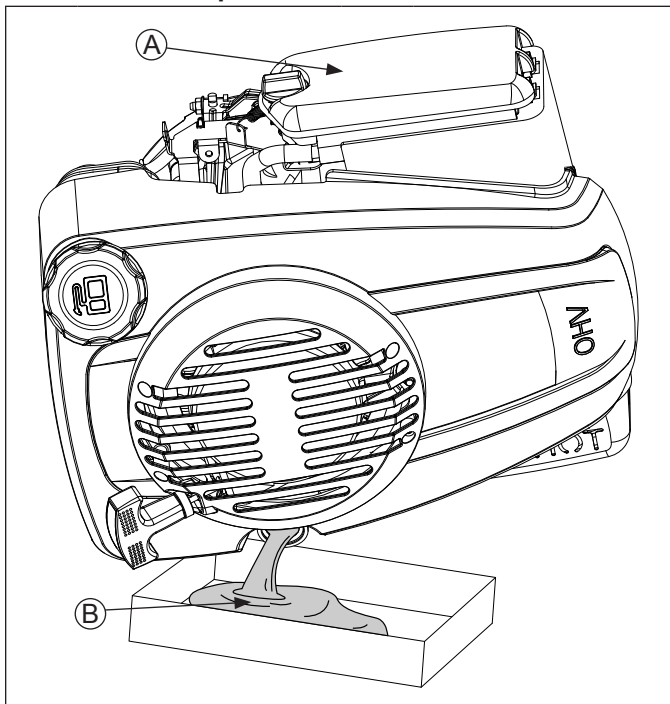

A	Air Cleaner	B	Oil
----------	-------------	----------	-----

1. To keep dirt, grass clippings, and other debris out of engine, clean area around oil fill cap/dipstick.
2. Remove oil fill cap/dipstick.
3. Tilt engine on its side with air cleaner facing up. Drain oil into an approved container.
4. After crankcase is completely drained, tilt engine back to level.
5. Dispose of used oil in accordance with local ordinances.

Drain Oil From Crankcase Plug (if accessible)

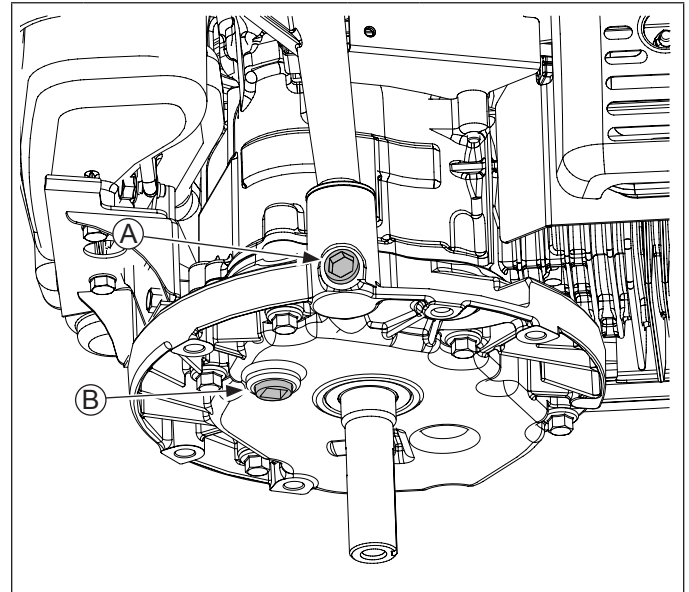

A	Crankcase Plug	B	Crankcase Plug (Bottom of Engine)
----------	----------------	----------	-----------------------------------

1. To keep dirt, grass clippings, and other debris out of engine, clean area around oil fill cap/dipstick, and then remove it.
2. Remove crankcase plug on bottom of engine.
3. Drain oil into an approved container.
4. Dispose of used oil in accordance with local ordinances.

Remove Engine Cover and Retractable Starter (if equipped)

NOTE: Whenever possible, an impact wrench should be used to loosen nuts securing retractable starter.

Remove nuts securing engine cover and retractable starter. Remove engine cover and retractable starter.

Remove Retractable Starter (if equipped)

Remove screws securing retractable starter assembly to engine.

Remove Blower Housing (if equipped)

Lift off blower housing and retain stud spacers.

Remove Muffler Assembly

NOTE: Muffler and guard is either secured with lock nuts on exhaust studs or with shoulder screws into exhaust port.

Remove nuts from exhaust studs and remove muffler guard; then slide muffler and gasket (heat deflector) from exhaust studs, noting gasket orientation. Or remove shoulder screws from exhaust port and remove muffler guard and muffler.

Disassembly/Inspection and Service

Remove Air Cleaner Assembly

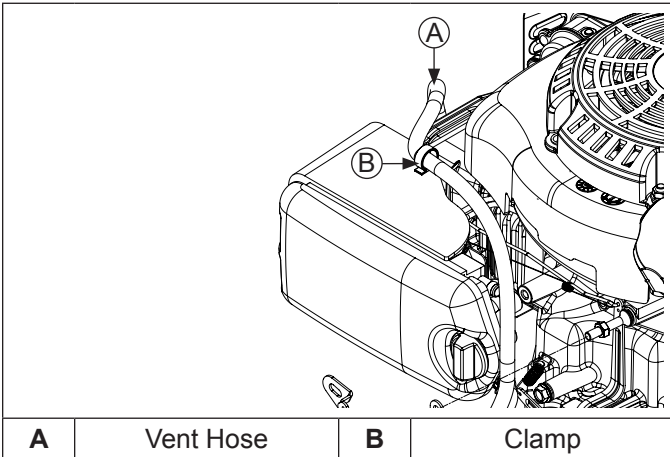

1. Loosen knob and remove air cleaner cover.
2. Remove precleaner and paper element.
3. Remove nuts securing air cleaner base to carburetor studs and screw securing base to crankcase.
4. Using Hose Removal Tool (See Tools and Aids), carefully remove breather hose from air cleaner base. (Other end is attached to crankcase.)
5. If engine is equipped with fuel pump, carefully disconnect clamp securing vent hose to air cleaner base.
6. Remove air cleaner base and air cleaner base gasket from studs noting gasket orientation; discard gasket.

Remove Fuel Pump (if equipped)

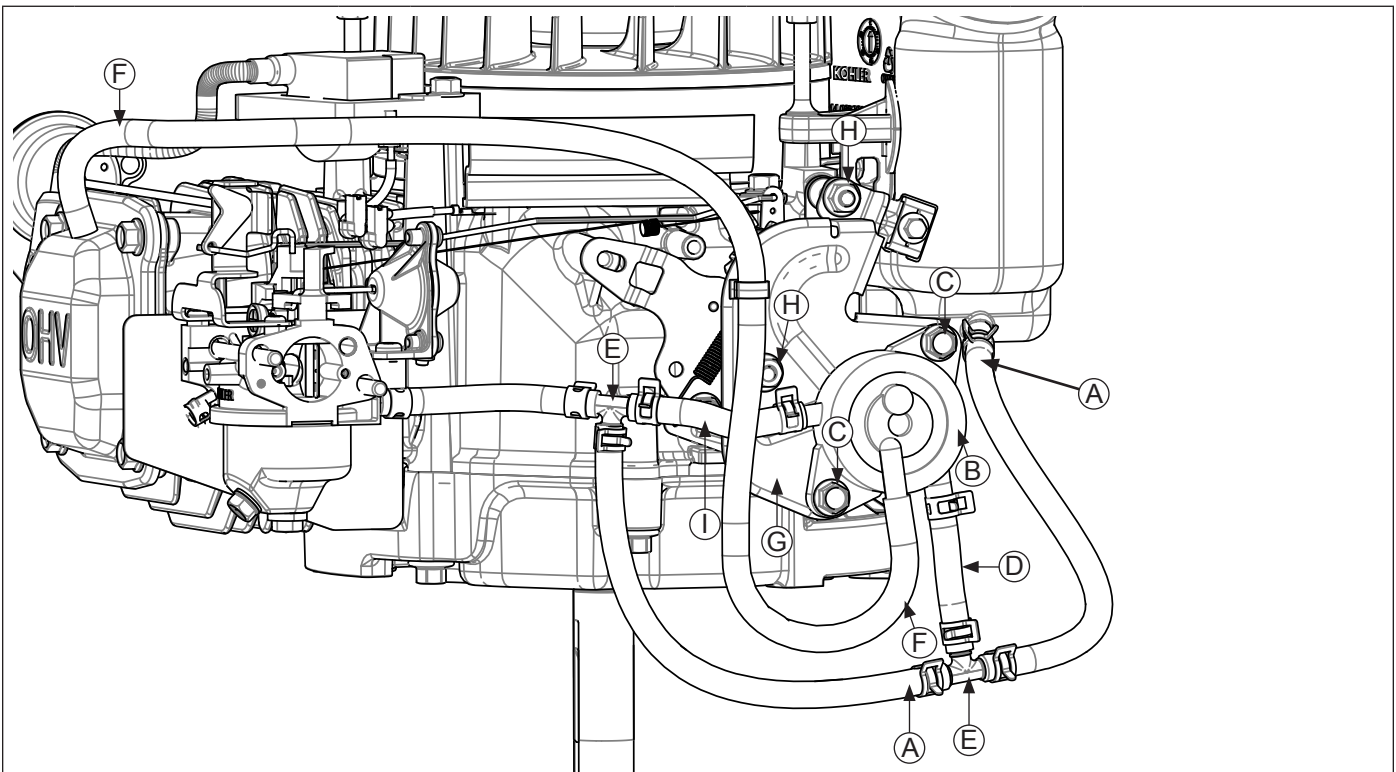

NOTE: Keep fuel lines connected to fuel pump and fuel pump on bracket unless any of these components need to be replaced.

1. Using Hose Removal Tool (see Tools and Aids), carefully remove vent hose from valve cover fitting.
2. Squeeze hose clamp and slide it up on fuel line (away from carburetor). Using Hose Removal Tool carefully remove fuel line from carburetor inlet fitting. Move clamp (away from tank) and disconnect fuel line from fuel tank. In-nipple fuel filter can stay in tank outlet.

- Remove nuts securing fuel pump bracket to engine. Remove fuel pump bracket, fuel pump, fuel lines from engine. On engines equipped with a fuel pump, top nut that secure fuel pump bracket also secures speed control assembly bracket to stud in crankcase.

Carburetor Components

Remove Carburetor with Standard Choke (if equipped)

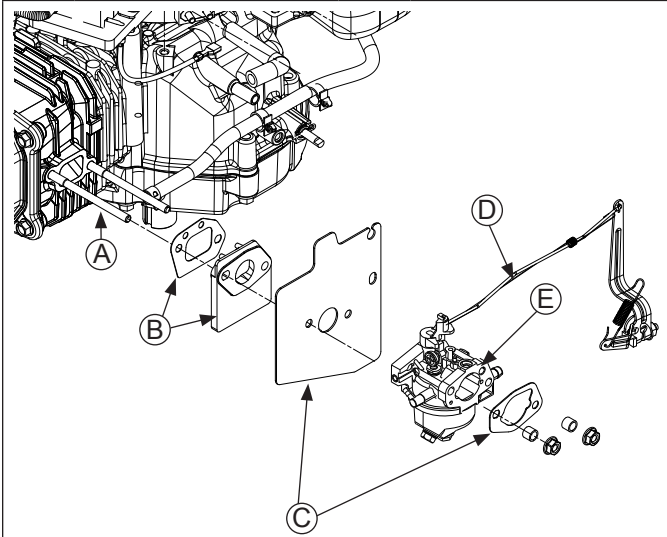

A	Carburetor Stud(s)	B	Gasket and Spacer Kit
C	Gasket and Heat Shield Kit	D	Linkage
E	Carburetor		

NOTE: Ensure fuel tank is empty by running engine until it stops, and is completely out of fuel.

- Squeeze hose clamp and slide it and fuel line off carburetor.
- Slide carburetor to end of intake studs.
- Turn throttle lever clockwise until it stops. Gently push rod and spring linkages up to disconnect them from throttle lever.
- Rotate carburetor until choke linkage can be disconnected from carburetor. If equipped.
- Slide off carburetor heat shield, spacer, and gasket, noting sequence.

Remove Carburetor with Auto Choke (if equipped)

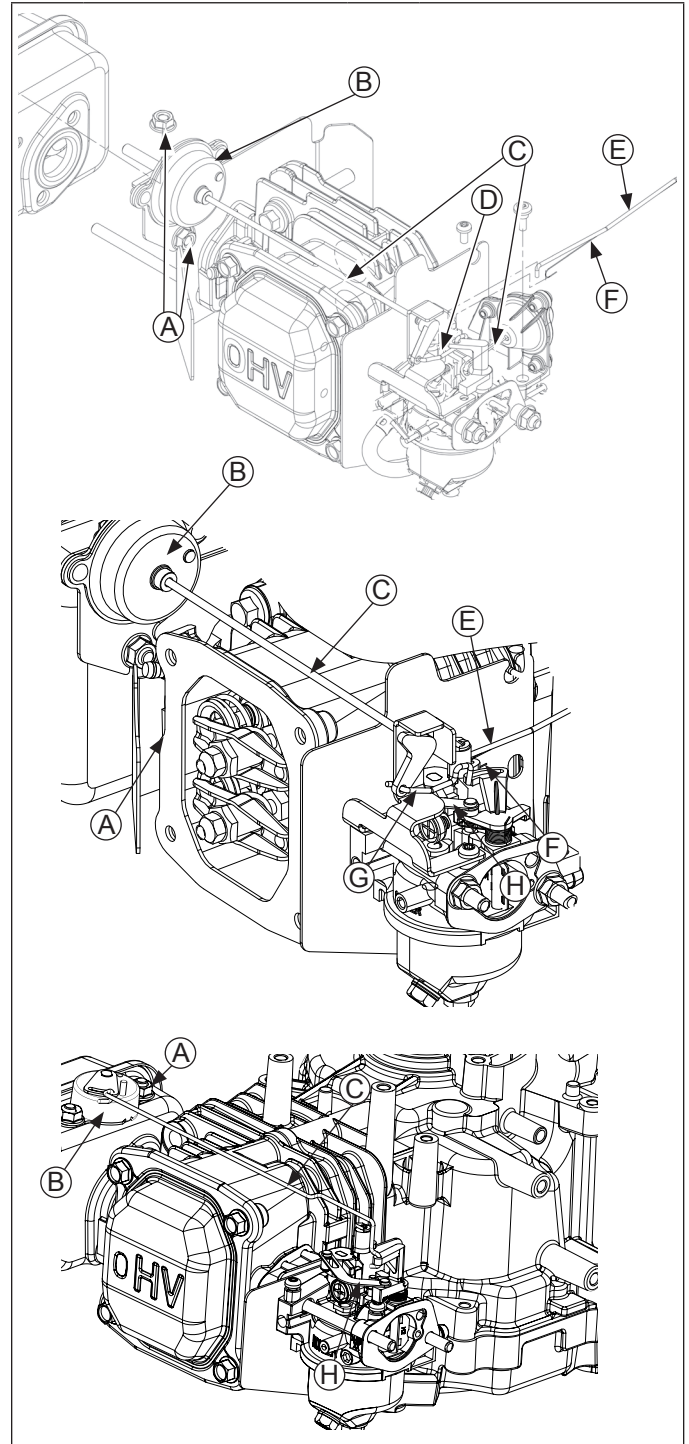

A	Nut(s)	B	Arm Assembly
C	Linkage	D	Choke Linkage
E	Governor Linkage	F	Linkage Spring
G	Wire Choke Linkage	H	Choke Link

- Remove screws securing arm assembly to carburetor.
- Disconnect fuel line.
- Remove wire choke linkage while sliding carburetor away from engine a couple of inches.

Disassembly/Inspection and Service

4. Disconnect governor linkage and linkage spring from carburetor.
5. Remove carburetor.
6. Remove nuts securing arm assembly to muffler. Second nut is located behind arm assembly base securing it to top of muffler.
7. Remove arm assembly from muffler.

Control Components

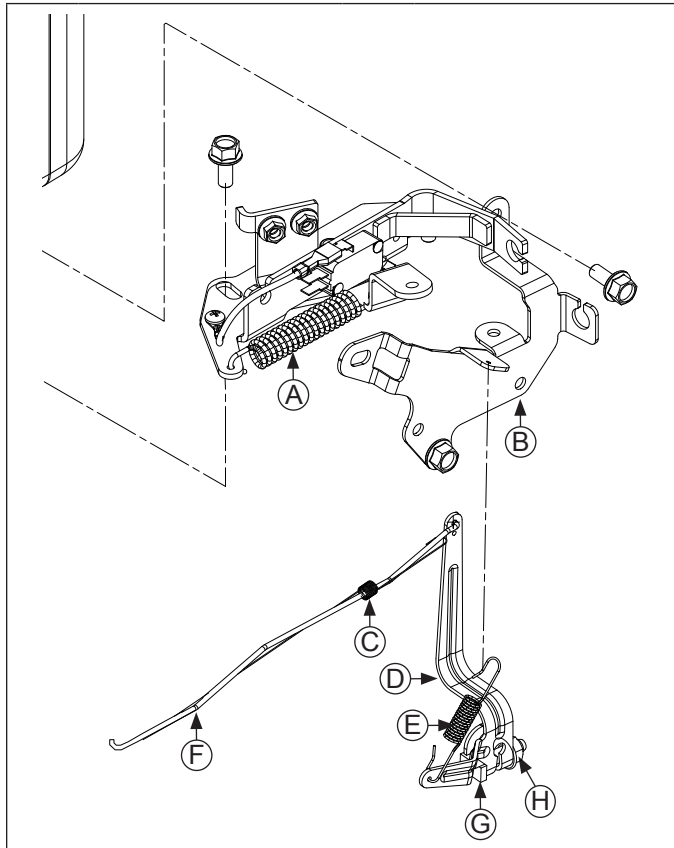

A	Flywheel Brake Spring	B	Fixed Speed Control Bracket
C	Linkage Spring	D	Governor Lever
E	Governor Spring	F	Throttle Linkage
G	Screw	H	Nut

Disconnect Governor Spring

Disconnect governor spring from speed control bracket.

Remove Speed Control Bracket

NOTE: Fuel hose connecting carburetor and fuel tank is held in place by a plastic ring(s), mounted on back of speed control bracket (except for engines equipped with fuel pump). If bracket is removed from crankcase, it will remain attached to fuel hose. Should replacement of speed bracket be required, disconnect fuel line from fuel filter or carburetor and slide bracket off hose. Do not disconnect fuel hose from fuel tank.

Remove screws securing speed control bracket.

Remove Governor Lever

Loosen governor lever nut and slide lever off governor shaft.

Flywheel/Ignition/Fuel Tank Components

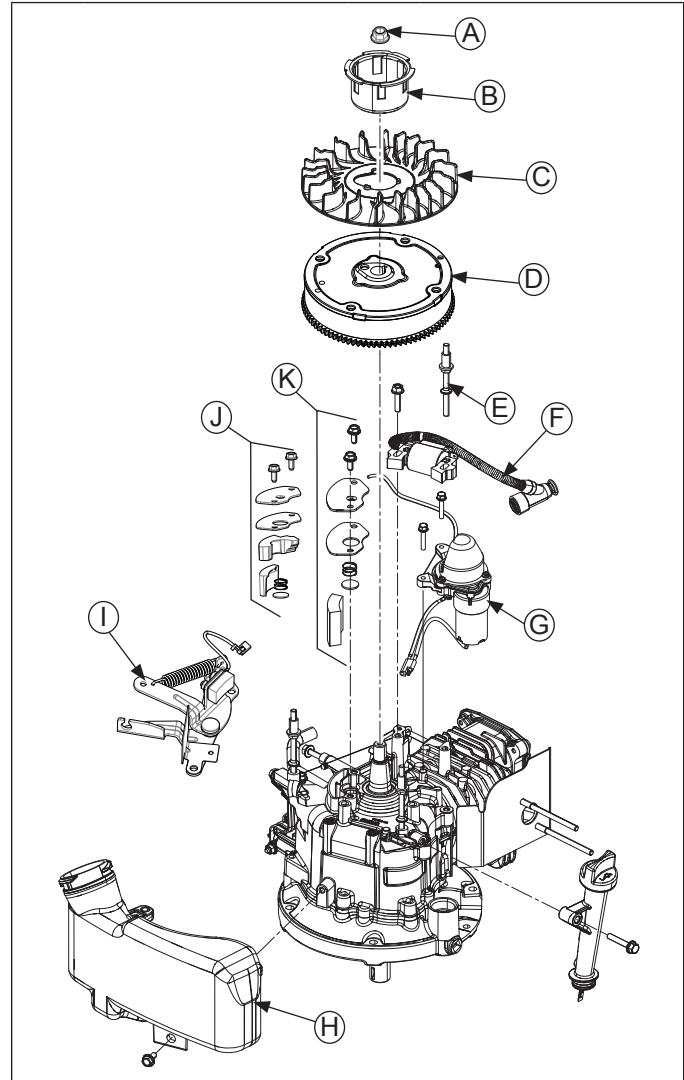

A	Flywheel Nut	B	Drive Cup
C	Fan	D	Flywheel
E	Ignition Module Stud	F	Ignition Module
G	Electric Starter (if equipped)	H	Fuel Tank
I	Flywheel Brake Spring (if equipped)	J	Two-Piece Breather Filter
K	One-Piece Breather Filter		

Remove Fuel Tank

1. Ensure fuel tank is empty.
2. Detach fuel tank from crankcase by removing screw.
3. Remove studs securing top of fuel tank and lift off tank.

Disassembly/Inspection and Service

Remove Ignition Module

1. Disconnect kill lead from ignition module.
2. Remove screw and stud securing ignition module. Mark stud for identification during reassembly.

Disconnect Flywheel Brake Spring (if equipped)

Grasp 1 end of flywheel brake spring with a pliers and stretch it to disconnect it.

Remove Flywheel

1. Using a flywheel strap wrench to hold flywheel, remove nut inside drive cup.
2. Remove drive cup and lift off fan, noting orientation on flywheel for reassembly.
3. Flywheel is mounted on a tapered shaft. To break it loose, use a rubber mallet to land a firm blow toward outer rim of flywheel. Remove flywheel.
4. Remove flywheel key from crankshaft.

Inspection

Inspect flywheel for cracks and check keyway for wear or damage. Replace flywheel if cracked. If flywheel key is sheared or keyway is damaged, replace crankshaft, flywheel, and key.

Inspect ring gear for cracks or damage. Ring gears are not available separately. Replace flywheel if ring gear is damaged.

Remove Electric Starter (if equipped)

Remove screws securing electric starter to engine.

Remove Stator (if equipped)

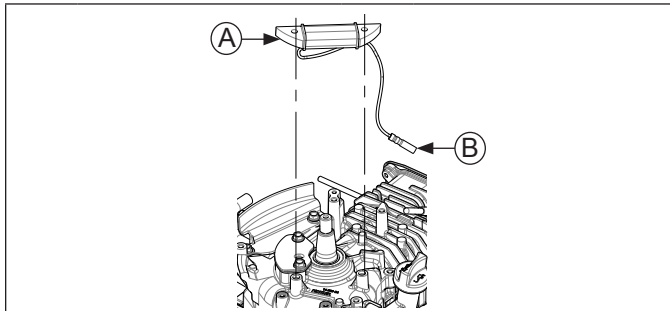

A	Stator (if equipped)	B	Connects to Diode
----------	----------------------	----------	-------------------

NOTE: Make note of stator position and routing of lead for reassembly.

Remove screws securing stator to crankcase posts. Stator terminal is connected to diode; move sleeving and disconnect terminal.

Remove Breather Assembly

Breather system is designed to control amount of oil in head area and still maintain necessary vacuum in crankcase.

When pistons move downward, crankcase gases are pushed past reed through mesh filter into intake system. Upward travel of pistons closes reed and creates a low vacuum in lower crankcase. Any oil separated out through filter drains back into crankcase.

NOTE: Some engines are built with a one-piece breather filter and some are built with a two-piece breather filter. Designs are not interchangeable.

1. Remove screws securing breather cover. Remove cover.
2. Remove breather spring, disc (breather reed) and breather filter.

Remove Spark Plug

Remove spark plug from cylinder head.

Remove Finger Guards (as equipped)

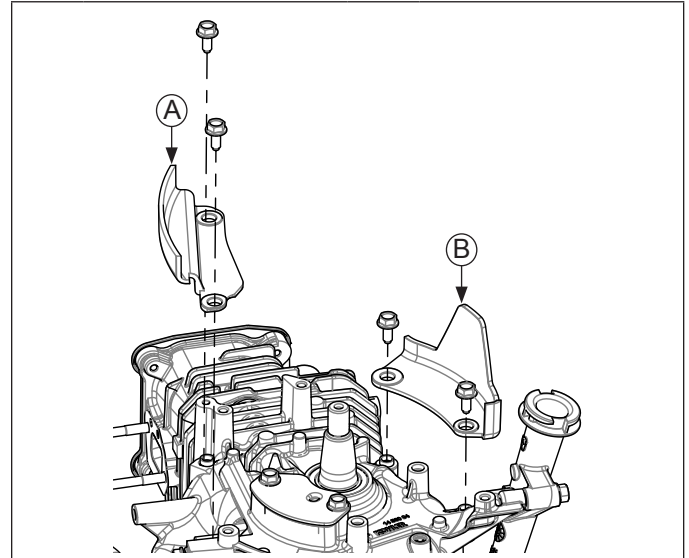

A	Finger Guard (Carburetor Side)	B	Finger Guard (Muffler Side)
----------	--------------------------------	----------	-----------------------------

Remove screws and finger guard(s) from crankcase.

Remove Flywheel Brake Assembly (if equipped)

Remove screws securing flywheel brake assembly; retain spacers (if equipped).

Disassembly/Inspection and Service

Cylinder Head Components

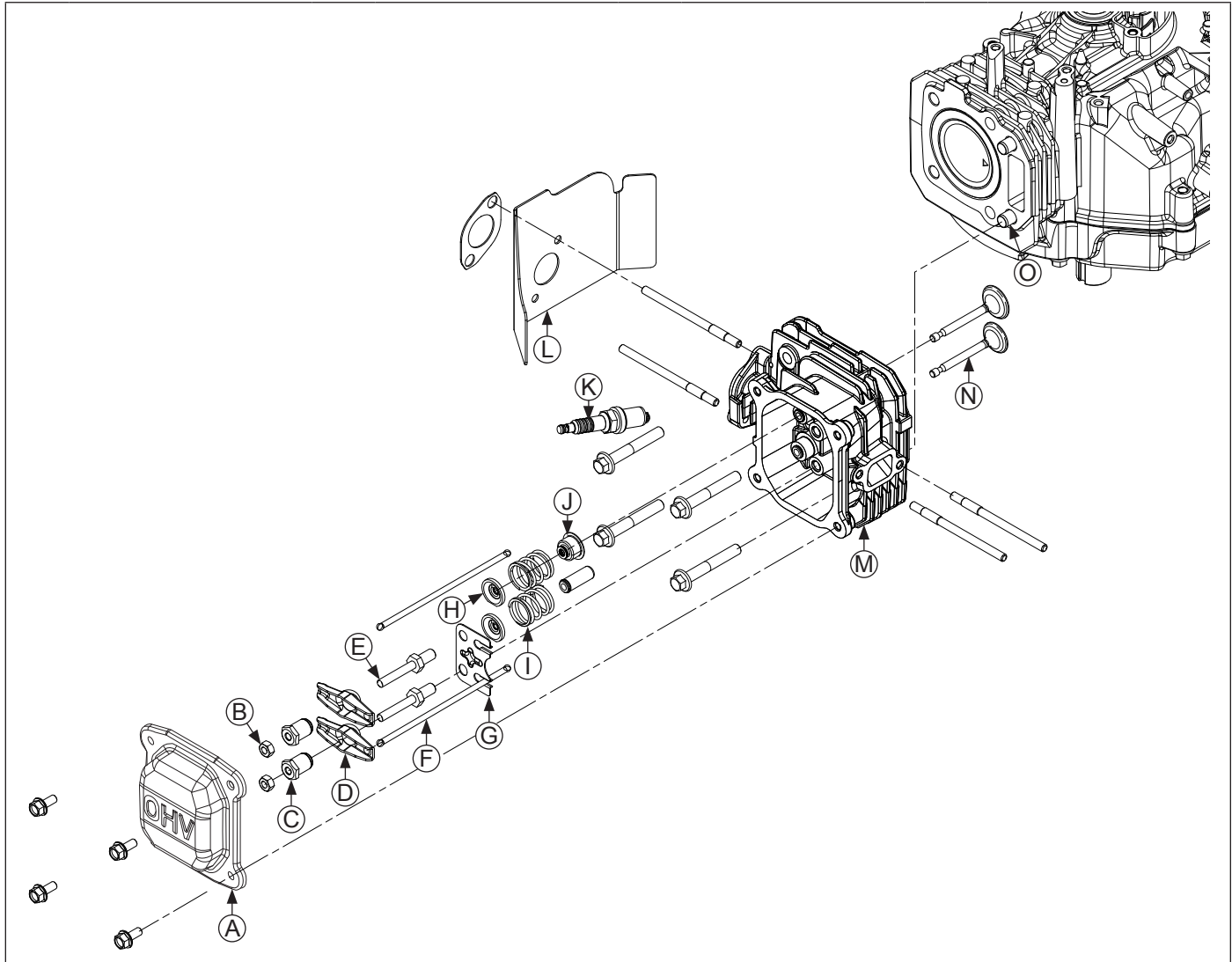

A	Valve Cover	B	Jam Nut	C	Rocker Arm Pivot	D	Rocker Arms
E	Rocker Arm Stud	F	Push Rod	G	Push Rod Guide Plate	H	Valve Keeper
I	Valve Spring	J	Intake Valve Seal	K	Spark Plug	L	Baffle
M	Cylinder Head	N	Valve	O	Dowel Pin		

Remove Valve Cover

NOTE: Valve cover is sealed to cylinder head using RTV silicone sealant. When removing valve cover, use care not to damage gasket surfaces of cover and cylinder head. To break RTV seal, hold a block of wood against 1 flat face of valve cover. Strike wood firmly with a mallet. If seal doesn't break loose after 1 or 2 attempts, repeat procedure on other side.

1. Remove screws securing valve cover.
2. Using a brass wire brush and gasket remover or similar solvent, clean old RTV from surface of cylinder head and valve cover.

Remove Jam Nuts and Rocker Arm Pivots

Use a socket and wrench to remove jam nuts and rocker arm pivots from rocker studs.

Remove Rocker Arms

Noting orientation, lift rocker arms off rocker studs.

Remove Push Rods

Remove push rods and mark them for reinstallation.

Remove Rocker Studs

Unscrew and remove rocker studs from cylinder head.

Disassembly/Inspection and Service

Remove Guide Plate

1. Remove guide plate from rocker studs.
2. Note orientation of guide plate (tabs down) for use during reassembly.

Remove Cylinder Head

1. Remove screws securing cylinder head.
2. Remove cylinder head, noting positioning of dowels.
3. Remove head gasket and discard.

Remove Valve Assembly

NOTE: Only intake valve has a seal. There is no valve seal on exhaust side.

1. Push down on valve spring keepers to release valve springs from valve stems.
2. Remove valve spring keepers and springs.
3. Push end of intake valve to release valve seal.
4. Remove both valves from opposite side of head.

Inspection and Service Valve Details

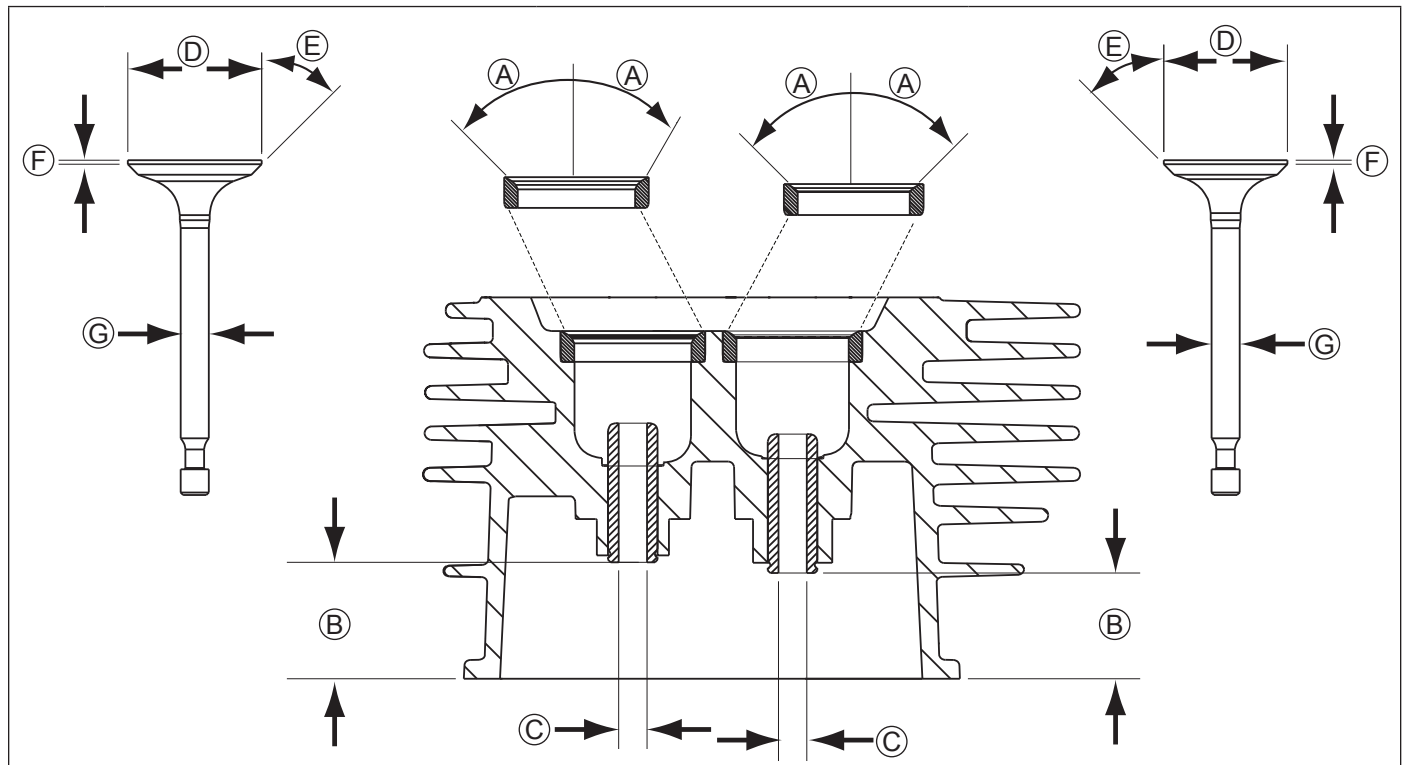

Dimension		Intake	Exhaust
A	Seat Angle	44.5°	44.5°
B	Guide Depth	22.6 mm	20.5 mm
C	Guide I.D.	5.500/5.512 mm	5.500/5.512 mm
D	Valve Head Diameter	25.875/26.125 mm	23.875/24.125 mm
E	Valve Face Angle	45°	45°
F	Valve Margin (Min.)	0.80 mm	0.80 mm
G	Valve Stem Diameter	5.465/5.480 mm	5.465/5.480 mm

Disassembly/Inspection and Service

After cleaning, check flatness of cylinder head and corresponding top surface of crankcase, using a surface plate or precision straight edge and feeler gauge. Maximum allowable out of flatness is 0.08 mm (0.003 in.).

Carefully inspect valve mechanism parts. Inspect valve springs and related hardware for excessive wear or distortion. Check valves and valve seats for evidence of deep pitting, cracks, or distortion.

Check running clearance between valve stems and guides.

Hard starting, or loss of power accompanied by high fuel consumption, may be symptoms of faulty valves. Although these symptoms could also be attributed to worn rings, remove and check valves first. After removal, clean valve heads, faces, and stems with a power wire brush. Then, carefully inspect each valve for defects such as warped head, excessive corrosion, or worn stem end. Replace valves found to be in bad condition.

Valve Guides

If a valve guide is worn beyond specifications, it will not guide valve in a straight line. This may result in burned valve faces or seats, loss of compression, and excessive oil consumption.

To check valve guide-to-valve stem clearance, thoroughly clean valve guide and, using a split-ball gauge, measure inside diameter. Then, using an outside micrometer, measure diameter of valve stem at several points on stem where it moves in valve guide. Use largest stem diameter to calculate clearance. If intake clearance exceeds 0.047 mm (.0018 in.) or exhaust clearance exceeds 0.082 mm (.0032 in.), determine whether valve stem or guide is responsible for excessive clearance.

Maximum (I.D.) wear on intake valve guide is 5.512 mm (0.2170 in.), while 5.512 mm (0.2170 in.) is maximum allowed on exhaust guide. Guides are not removable. If guides are within limits but valve stems are worn beyond limits, replace valves.

Valve Seat Inserts

Hardened steel alloy intake and exhaust valve seat inserts are press fitted into cylinder head. Inserts are not replaceable, but they can be reconditioned if not too badly pitted or distorted. If seats are cracked or badly warped, cylinder head should be replaced.

Recondition valve seat inserts following instructions provided with valve seat cutter (A) being used. Final cut should be made with an 90° cutter as specified for valve seat angle. With proper 45° valve face angle, and valve seat cut properly (44.5° as measured from center line when cut 90°) this would result in desired 0.5° (1.0° full cut) interference angle where maximum pressure occurs on valve face and seat.

Lapping Valves

Reground or new valves must be lapped in, to provide a good seal. Use a hand valve grinder with suction cup for final lapping. Lightly coat valve face with fine grade of grinding compound, then rotate valve on seat with grinder. Continue grinding until smooth surface is obtained on seat and on valve face. Thoroughly clean cylinder head in soap and hot water to remove all traces of grinding compound. After drying cylinder head, apply a light coating of engine oil to prevent rusting.

Crankcase Components

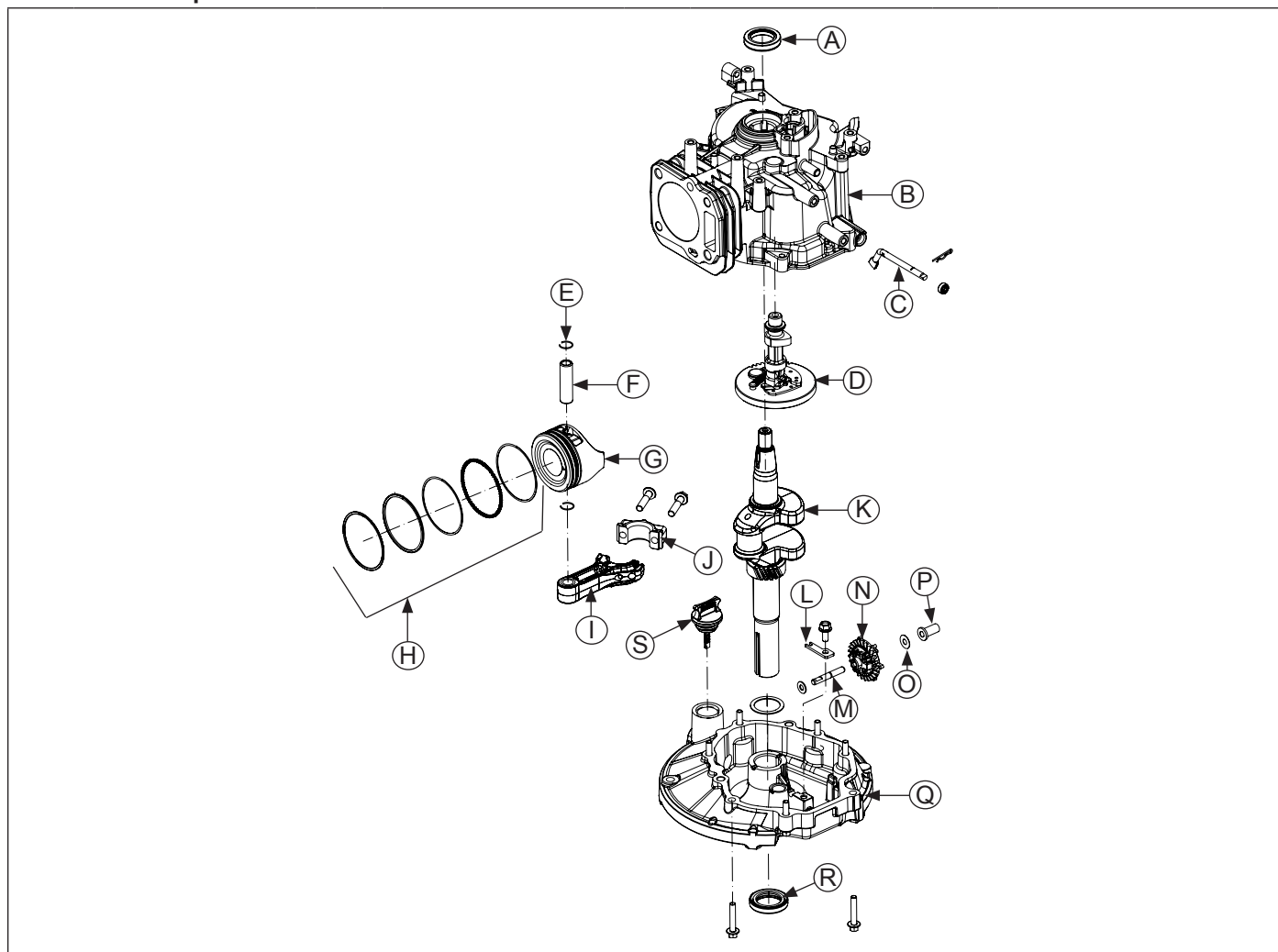

A	Crankcase Oil Seal	B	Crankcase	C	Governor Cross Shaft	D	Camshaft
E	Piston Pin Retainer	F	Piston Pin	G	Piston	H	Piston Ring Set
I	Connecting Rod	J	Connecting Rod End Cap	K	Crankshaft	L	Retainer
M	Governor Shaft	N	Governor Gear	O	Governor Washer	P	Governor Cup
Q	Oil Pan	R	Oil Pan Oil Seal	S	Dipstick Assembly (if equipped)		

Remove Oil Pan

1. Remove screws securing oil pan.
2. Using a flat blade screwdriver as a wedge, carefully separate oil pan from crankcase.

Inspection

Inspect oil seal in oil pan and remove it if it is worn or damaged.

Remove Camshaft

Remove camshaft from crankcase.

Inspection and Service

Inspect gear teeth of camshaft. If teeth are badly worn or chipped, or if some are missing, replacement of camshaft will be necessary. If unusual wear or damage is evident on either camshaft lobes or mating tappets camshaft and both tappets must be replaced. Check condition and operation of Automatic Compression Release (ACR) mechanism.

Disassembly/Inspection and Service

ACR

These engines are equipped with an ACR mechanism. ACR lowers compression at cranking speeds to make starting easier.

ACR mechanism consists of a decompression weight and arm mounted to camshaft, and activated by a return spring. When engine is rotating at low cranking speeds (1000 RPM or less), decompression weight holds arm so it protrudes above heel of exhaust lobe. This holds exhaust valve off its seat during first part of compression stroke.

After engine speed increases above approximately 1000 RPM, centrifugal force causes decompression weight to move outward, causing arm to retract. When in this position, arm has no effect on exhaust valve and engine operates at FULL compression and power.

Benefits

As a result of reduced compression at cranking speeds, several important benefits are obtained:

1. Manual (retractable) starting is much easier. Without ACR, manual starting would be virtually impossible.
2. Electric start models can use a smaller starter and battery which are more practical for application.
3. ACR eliminates need for a spark retard/advance mechanism. A spark retard/advance mechanism would be required on engines without ACR to prevent kickback which would occur during starting. ACR eliminates this kickback, making manual starting safer.
4. Choke control setting is less critical with ACR. If flooding occurs, excess fuel is blown out opened exhaust valve and does not hamper starting.
5. Engines with ACR start much faster in cold weather than engines without ACR.
6. Engines with ACR can be started with spark plugs which are worn or fouled. Engines without ACR are more difficult to start with those same spark plugs.

Remove Governor Gear and Shaft

1. Remove screw and retainer securing governor gear.
2. Remove hitch pin securing governor shaft. Remove shaft.

Inspection

Inspect governor gear teeth. Replace gear if it is worn, chipped, or if any teeth are missing. Inspect governor weights. They should move freely in governor gear.

Remove Tappets

Remove tappets. Mark them INTAKE and EXHAUST for reinstallation.

Remove Connecting Rod Cap

Rotate crankshaft to allow access to 2 screws on connecting rod cap. Remove screws and cap.

Remove Piston and Connecting Rod

Carefully guide piston and attached connecting rod out of cylinder bore.

Connecting Rod Inspection and Service

Check bearing area (big end) for excessive wear, score marks, running and side clearances. Replace connecting rod and end cap if scored or excessively worn.

Service replacement connecting rods are available in STD size.

Piston and Rings Inspection

Scuffing and scoring of pistons and cylinder walls occurs when internal engine temperatures approach welding point of piston. Temperatures high enough to do this are created by friction, which is usually attributed to improper lubrication and/or overheating of engine.

Normally, very little wear takes place in piston boss or piston pin area. If original piston and connecting rod can be reused after new rings are installed, original pin can also be reused but new piston pin retainers are required. Piston pin is included as part of piston assembly – if pin boss in piston or pin itself is worn or damaged, a new piston assembly is required.

Ring failure is usually indicated by excessive oil consumption and blue exhaust smoke. When rings fail, oil is allowed to enter combustion chamber where it is burned along with fuel. High oil consumption can also occur when piston ring end gap is incorrect, because ring cannot properly conform to cylinder wall under this condition. Oil control is also lost when ring gaps are not staggered during installation.

When cylinder temperatures get too high, lacquer and varnish collect on pistons, causing rings to stick, which results in rapid wear. A worn ring usually takes on a shiny or bright appearance.

Scratches on rings and pistons are caused by abrasive material such as carbon, dirt, or pieces of hard metal.

Detonation damage occurs when a portion of fuel charge ignites spontaneously from heat and pressure shortly after ignition. This creates two flame fronts, which meet and explode to create extreme hammering pressures on a specific area of piston. Detonation generally occurs from using low octane fuels.

Preignition or ignition of fuel charge before timed spark can cause damage similar to detonation. Preignition damage is often more severe than detonation damage. Preignition is caused by a hot spot in combustion chamber such as glowing carbon deposits, blocked cooling fins, an improperly seated valve, or a wrong spark plug.

Replacement pistons are available in STD bore size. Replacement pistons include new piston ring sets and new piston pins.

Replacement ring sets are also available separately for STD pistons. Always use new piston rings when installing pistons. Never use old rings.

Disassembly/Inspection and Service

Some important points to remember when servicing piston rings:

1. Cylinder bore must be de-glazed before service ring sets are used.
2. If cylinder bore does not need re-boring and if old piston is within wear limits and free of score or scuff marks, old piston may be reused.
3. Remove old rings and clean up grooves. Never reuse old rings.
4. Before installing new rings on piston, place top 2 rings, each in turn, in its running area in cylinder bore and check end gap. Compare ring gap to Clearance Specifications.
5. After installing new compression (top and middle) rings on piston, check piston-to-ring side clearance. Compare clearance to Clearance Specifications. If side clearance is greater than specified, a new piston must be used.

Install New Piston Rings

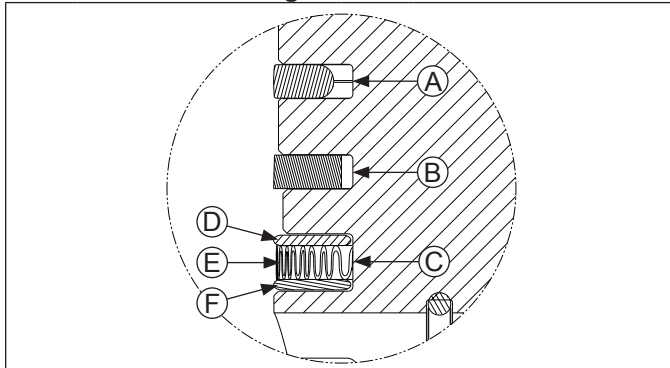

A	Top Compression Ring	B	Middle Compression Ring
C	Oil Control Ring	D	Top Rail
E	Expander Ring	F	Bottom Rail

Piston Ring Orientation

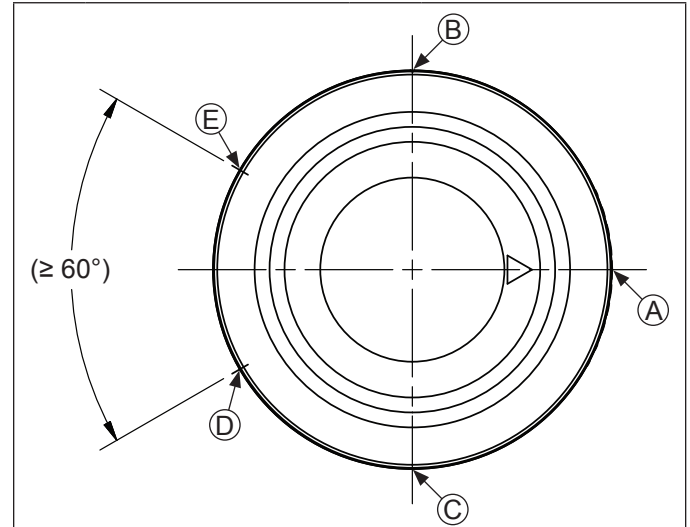

A	Oil Ring Expander Gap	B	Bottom Oil Rail Gap
C	Top Oil Rail Gap	D	Middle Compression Ring Gap
E	Top Compression Ring Gap		

NOTE: Rings must be installed correctly. Install oil control ring assembly (bottom groove) first, middle compression ring (center groove) second, and top compression ring (top groove) last. Oil control ring assembly is a three-piece design, and consists of a top rail, expander ring, and bottom rail.

Use a piston ring expander to install rings.

1. Oil control ring assembly (bottom groove): Install expander first then bottom rail and top rail last. Make sure ends of expander are not overlapped. Adjust ring gaps.
2. Middle compression ring (center groove): Install middle compression ring using a piston ring expander tool. Make sure identification mark is up or colored dye stripe (if contained) is left of end gap. Adjust ring gaps.
3. Top compression ring (top groove): Install top compression ring using a piston ring expander tool. Make sure identification mark is up or colored dye stripe (if contained) is left of end gap. Adjust ring gaps.

Disassembly/Inspection and Service

Remove Crankshaft

Remove crankshaft.

Inspection and Service

Inspect gear teeth of crankshaft and ACR gear. If any teeth are badly worn or chipped, or if some are missing, replacement of crankshaft will be necessary.

Inspect crankshaft bearing surfaces for scoring, grooving, etc. Measure running clearance between crankshaft journals and their respective bearing bores. Use an inside micrometer or telescoping gauge to measure inside diameter of both bearing bores in vertical and horizontal planes. Use an outside micrometer to measure outside diameter of crankshaft main bearing journals. Subtract journal diameters from their respective bore diameters to get running clearances. Check results against values in Specifications and Tolerances. If running clearances are within specification, and there is no evidence of scoring, grooving, etc., no further reconditioning is necessary. If bearing surfaces are worn or damaged, crankcase and/or closure plate will need to be replaced.

Inspect crankshaft keyway. If worn or chipped, replacement of crankshaft will be necessary.

Inspect crankpin for score marks or metallic pickup. Slight score marks can be cleaned with crocus cloth soaked in oil. If wear limits in Specifications are exceeded, it will be necessary to replace crankshaft.

Crankcase

Inspection and Service

Check all gasket surfaces to make sure they are free of gasket fragments and deep scratches or nicks.

Check cylinder wall for scoring. In severe cases, unburned fuel can dissolve lubricating oil off piston and cylinder wall. Without lubrication, piston rings would make metal to metal contact with wall, causing scuffing and scoring. Scoring of cylinder wall can also be caused by localized hot spots from blocked cooling fins or from inadequate or contaminated lubrication.

Crankcase Components

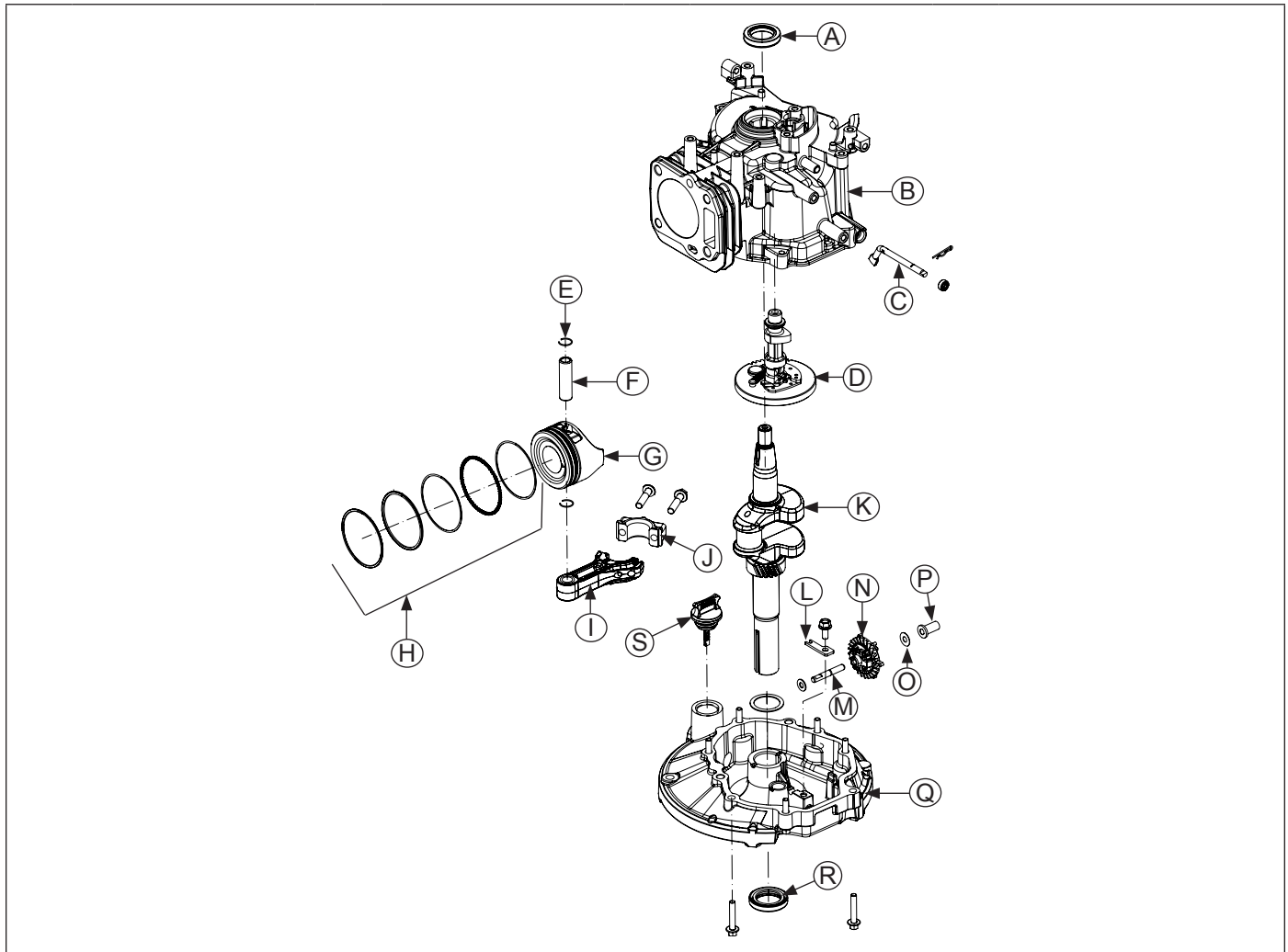

A	Crankcase Oil Seal	B	Crankcase	C	Governor Cross Shaft	D	Camshaft
E	Piston Pin Retainer	F	Piston Pin	G	Piston	H	Piston Ring Set
I	Connecting Rod	J	Connecting Rod End Cap	K	Crankshaft	L	Retainer
M	Governor Shaft	N	Governor Gear	O	Governor Washer	P	Governor Cup
Q	Oil Pan	R	Oil Pan Oil Seal	S	Dipstick Assembly (if equipped)		

NOTE: Make sure engine is assembled using all specified torque values, tightening sequences, and clearances. Failure to observe specifications could cause severe engine wear or damage.

NOTE: Always use new gaskets.

NOTE: Make sure all components have been properly cleaned BEFORE reassembly.

NOTE: Remove all traces of cleaners before engine is reassembled and placed into operation. Even small amounts of these cleaners can quickly break down lubricating properties of engine oil.

Install Crankshaft

Carefully install crankshaft into crankcase through front seal, and fully seat into place. Rotate crankshaft until journal for connecting rod is away from cylinder.

Reassembly

Install Piston and Connecting Rod

NOTE: Proper orientation of piston and connecting rod inside engine is extremely important. Improper orientation can cause extensive wear or damage.

1. Stagger piston rings in grooves until end gaps are 60° or more apart. Lubricate cylinder bore, crankshaft journal, connecting rod journal, piston, and rings with engine oil.
2. Compress piston rings using a piston ring compressor.
3. Position triangle on top of piston toward push rod chamber.
4. Carefully guide connecting rod, with piston attached, into bore.
5. Use handle of a soft, rubber-grip hammer to tap piston into bore.
6. Rotate crankshaft to mate with connecting rod. Align rod cap and connecting rod to match marks. Torque screws to 12.5 N·m (110 in. lb.).

Install Tappets

Install intake and exhaust tappets into their respective positions, as previously marked.

Install Camshaft

1. Lubricate camshaft and cam gear surfaces with light grease or oil.
2. Install camshaft and align timing marks.

Install Governor Gear Assembly

NOTE: When installing governor, flat of governor shaft (located on outside of crankcase) should be turned so flat is parallel to crankcase gasket surface. Paddle of governor shaft (located inside crankcase) should be pointing away from crankcase gasket surface.

1. Install governor gear and retainer, and torque screw to 9.5 N·m (84 in. lb.).
2. Install governor cross shaft and secure it with hitch pin.

Install Oil Pan

Torque Sequence

HD775

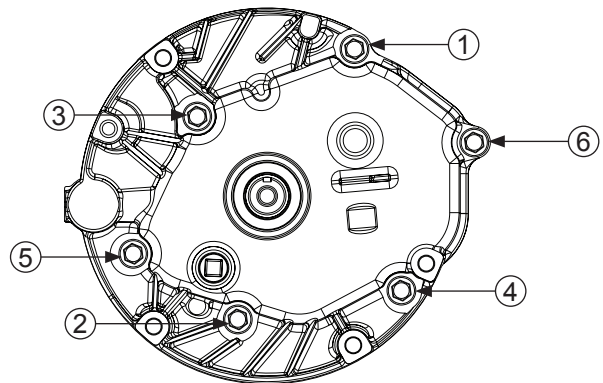

HD675

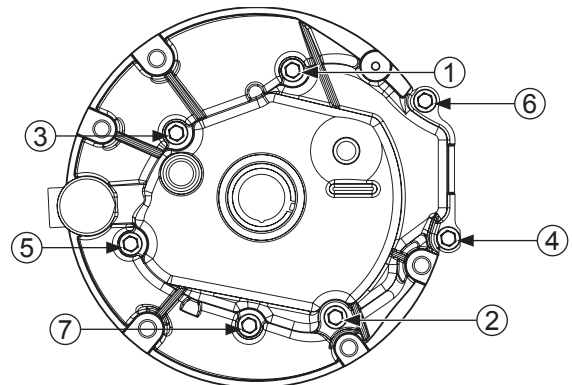

Sealant Pattern

HD775

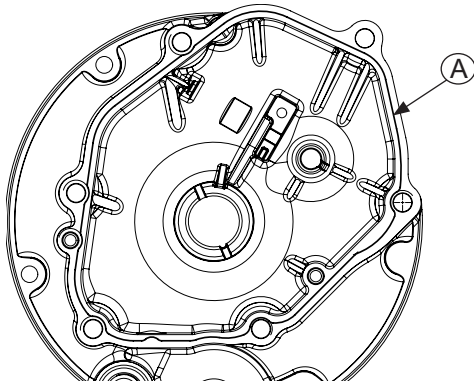

HD675

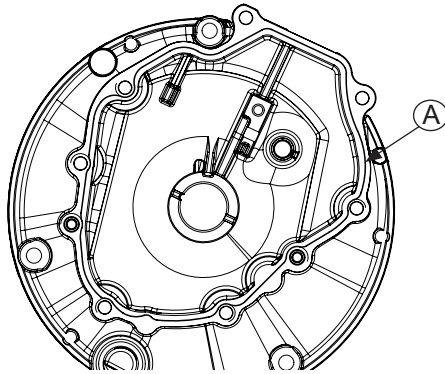

A 1.5 mm (1/16 in.) bead of sealant.

NOTE: When installing oil pan, ensure plunger on governor gear is pressed fully into governor. Incorrectly installing governor plunger may result in damage.

NOTE: Always use fresh sealant. Using outdated sealant can result in leakage. Use Permatex® Ultra Grey® sealant.

1. Sealing surfaces of crankcase and oil pan should be clean, dry and free of any nicks or burrs.
2. Install 2 crankcase dowels into crankcase.
3. Apply a 1.5 mm (1/16 in.) bead of Permatex® Ultra Grey® sealant to sealing surface of oil pan. See sealant pattern for engine being serviced. Oil pan must be installed within 10 minutes of RTV application.

4. Guide oil pan onto crankcase, ensuring camshaft and governor gear align with their mating surfaces. Rotate crankshaft slightly to help engage governor gear.
5. Install and finger tighten screws, securing oil pan to crankcase.
6. Use torque sequence shown and torque oil pan screws to:

Model	Torque
HD675	11.0 N·m (98 in. lb.)
HD775	14.7 N·m (130 in. lb.)

Reassembly

Cylinder Head Components

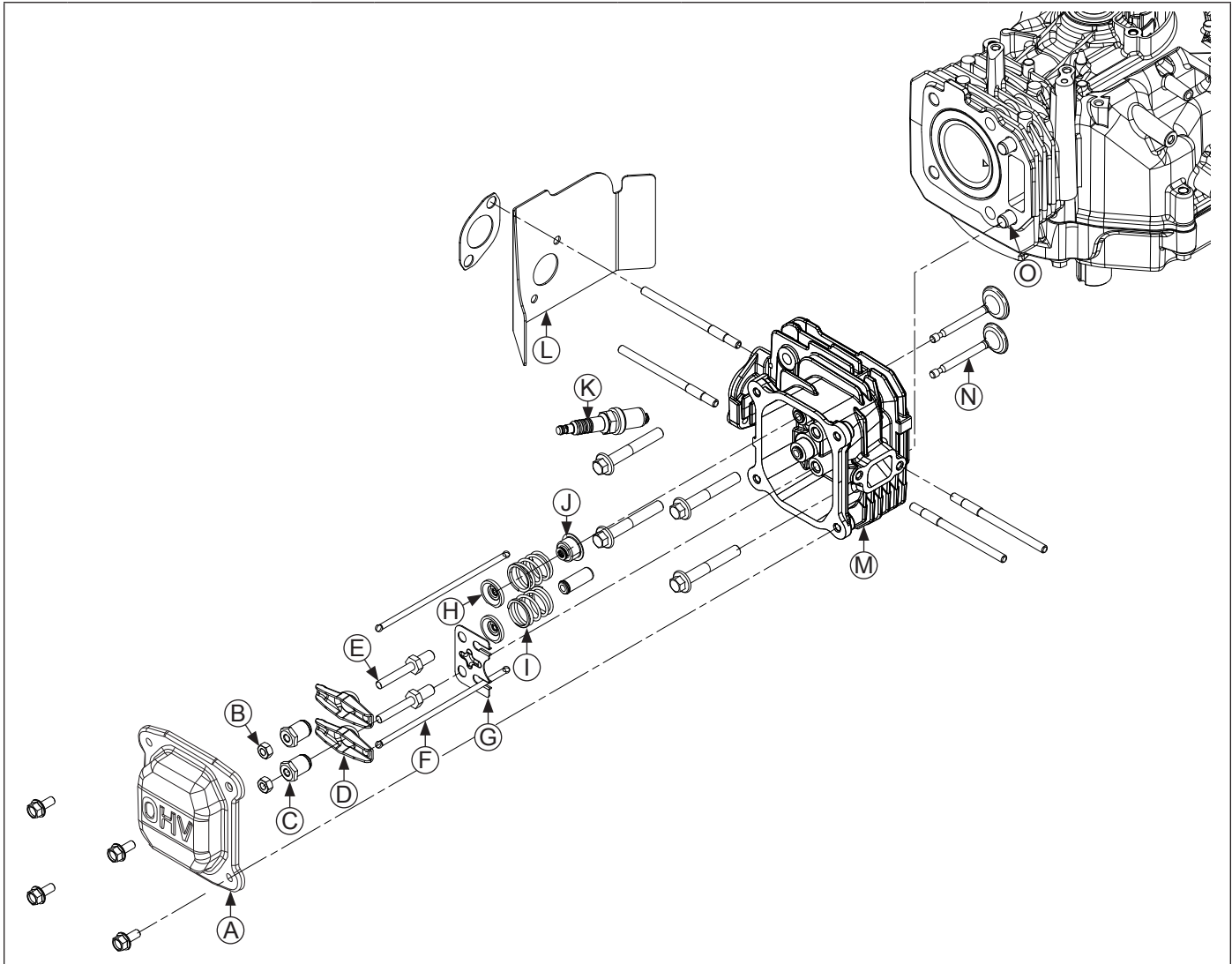

A	Valve Cover	B	Jam Nut	C	Rocker Arm Pivot	D	Rocker Arms
E	Rocker Arm Stud	F	Push Rod	G	Push Rod Guide Plate	H	Valve Keeper
I	Valve Spring	J	Intake Valve Seal	K	Spark Plug	L	Baffle
M	Cylinder Head	N	Valve	O	Dowel Pin		

Install Cylinder Head Assembly

Prior to assembly, lubricate all components with engine oil, including tips of valve stems and valve guides.

Install Valve Train

1. Install intake and exhaust valves into their respective positions in cylinder head.
2. Install intake valve seal onto intake valve. Next, slide valve springs onto both valves and lock them in place with valve spring keepers.

Install Cylinder Head

Torque Sequence

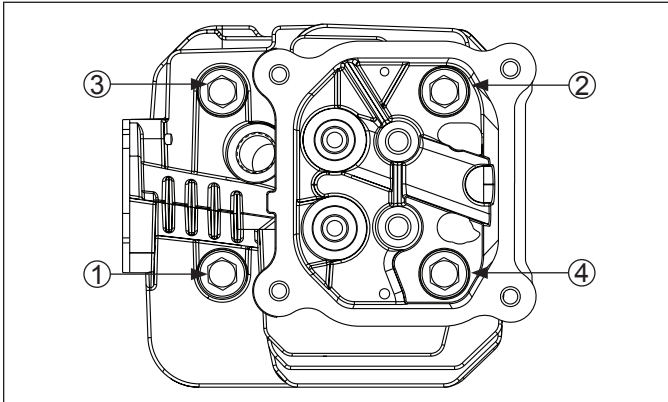

NOTE: Do not reuse cylinder head gasket. Always replace with new gasket.

1. Examine sealing surfaces of cylinder head and crankcase for nicks or burrs.
2. Using cylinder head dowels as a guide, install a new head gasket.
3. Match sides of head together and finger tighten screws.
4. Torque screws in two stages; first to 14 N·m (123 in. lb.), finally to 27.8 N·m (246 in. lb.), following sequence shown.

Install Push Rod Assembly

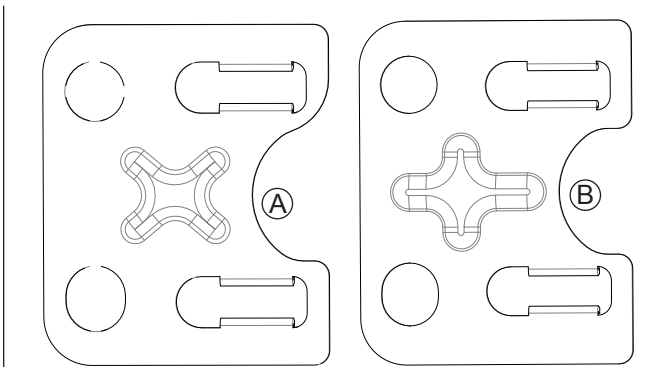

A	HD675 Guide Plate	B	HD775 Guide Plate
----------	-------------------	----------	-------------------

NOTE: Installation and seating of push rods into tappet recesses during this sequence is critical. To aid with proper installation of push rods and rocker arms, and for adjusting valve lash, position engine with cylinder head up. When properly installed, push rods extend approximately 1 in. (25.4 mm) above guide plate.

1. With tabs on guide plate facing down, install install guide plate and secure with rocker studs.
2. Tighten rocker studs to 13.6 N·m (120 in. lb.).
3. Install push rods into intake and exhaust positions, as previously marked.
4. Apply grease to contact surfaces of rocker arms and pivots.

5. Install rocker arms onto rocker studs. Match rocker arm dimples with round push rod ends.
6. Loosely install pivots and jam nuts onto rocker studs.
7. With rocker arms and push rods in their correct position, inspect push rod to guide plate clearance. Push rods need to be centered in guide plate opening. If contact is present, readjust guide plate starting in step 1.
8. With piston at top dead center of compression stroke, insert a 0.1 mm (0.004 in.) flat feeler gauge between 1 valve stem and rocker arm.
Valve Clearance Specifications:
Intake Valve 0.0762-0.127 mm (0.003-0.005 in.)
Exhaust Valve 0.0762-0.127 mm (0.003-0.005 in.)
9. Tighten rocker pivot with a wrench until a slight drag is felt on feeler gauge. Hold nut in position and tighten jam nut to 9.5 N·m (84 in. lb.). Recheck lash. Perform same adjustment procedure on opposite valve.

Install Valve Cover

Torque Sequence

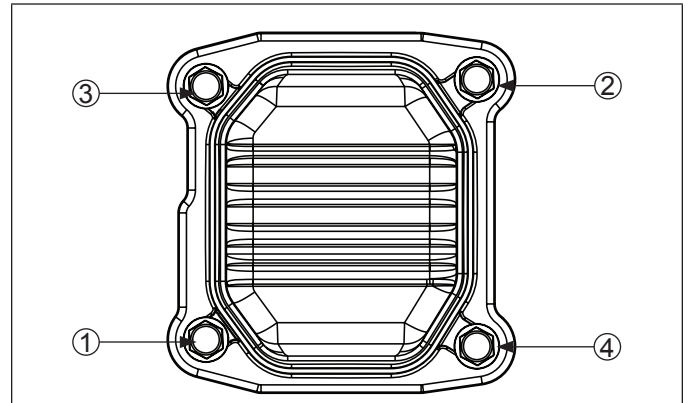

Sealant Pattern

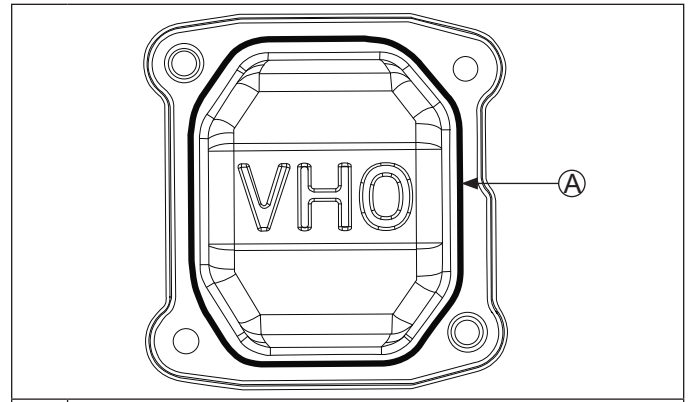

A	RTV Sealant
----------	-------------

NOTE: Always use fresh sealant. Using outdated sealant can result in leakage. Use Permatex® Ultra Grey® sealant.

NOTE: To ensure proper adhesion of sealant to both sealing surfaces, perform step 3 immediately (10 minutes maximum) after application of RTV.

1. Prepare sealing surface of cylinder head and valve cover.

Reassembly

2. Apply a 1.5 mm (1/16 in.) bead of Permatex® Ultra Grey® sealant to valve cover as shown. Valve cover must be installed within 10 minutes of RTV application.
3. Install valve cover and finger tighten screws.
4. Using sequence shown, tighten cover screws to 8 N·m (71 in. lb.).

Install New Spark Plug

1. Set gap of a new spark plug to 0.76 mm (0.030 in.).
2. Install spark plug and torque to 27 N·m (20 ft. lb.).

Install Flywheel Brake Assembly (if equipped)

1. Place brake assembly onto engine and loosely install 2 brake assembly screws.
2. Install a caliper between brake lever and bracket to establish a 50 mm (1.968 in.) gap, pivoting on rear screw if necessary.
3. Rotate brake lever clockwise around rear screw. Torque screws to 9.5 N·m (84 in. lb.). Reinstall kill lead to ignition module or to bottom terminal on micro switch (if equipped).
4. Actuate brake arm and verify an audible click is heard from micro switch (if equipped). Visually inspect all wires are connected and micro switch is moving up and down when brake arm is pulled. If an audible click from micro switch is not heard, loosen both screws and readjust.

Install Finger Guards (as equipped)

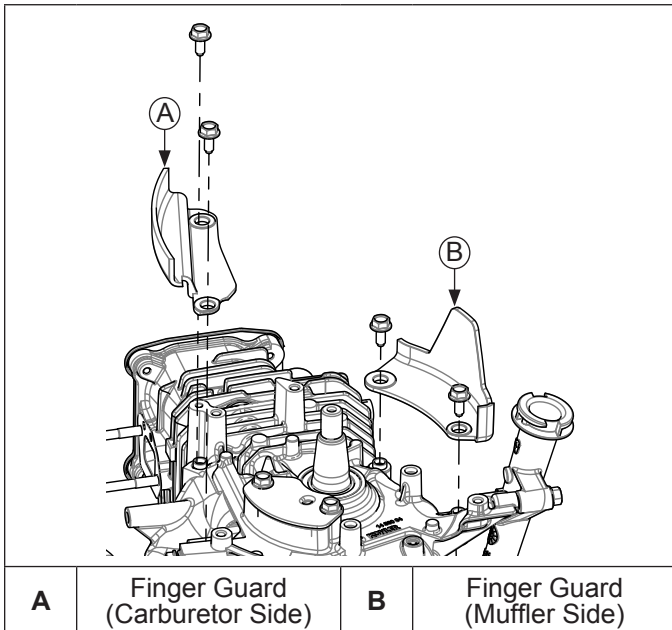

Install finger guards and secure with screws. Torque screws to 9.5 N·m (84 in. lb.).

Flywheel/Ignition/Fuel Tank Components

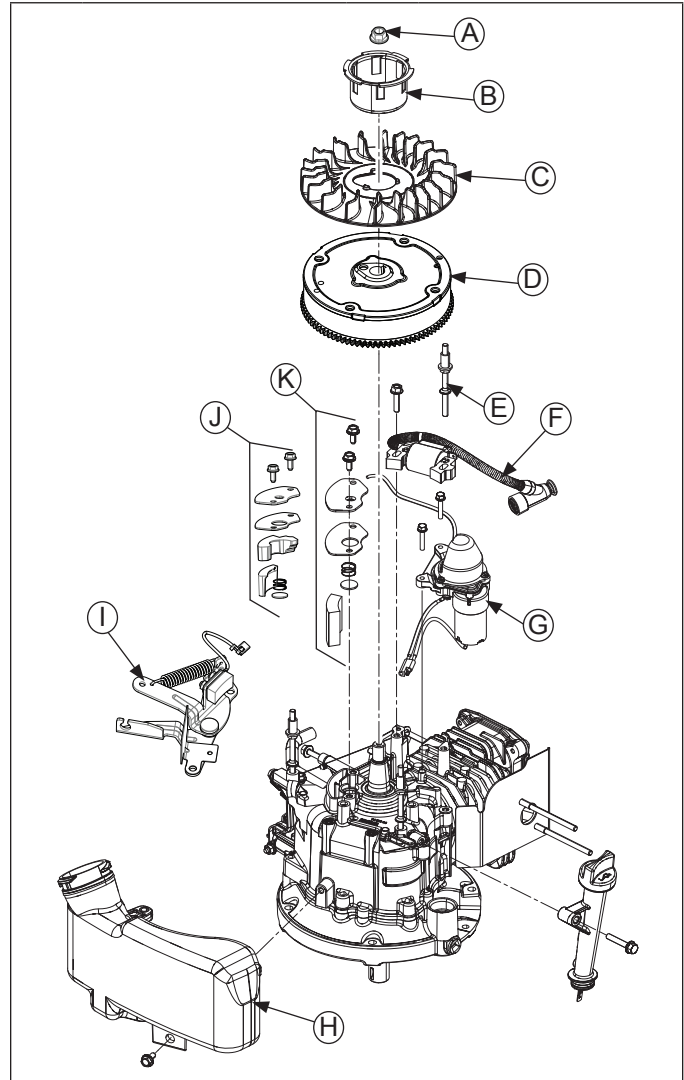

A	Flywheel Nut	B	Drive Cup
C	Fan	D	Flywheel
E	Ignition Module Stud	F	Ignition Module
G	Electric Starter (if equipped)	H	Fuel Tank
I	Flywheel Brake Spring (if equipped)	J	Two-Piece Breather Filter
K	One-Piece Breather Filter		

Install Breather Assembly

NOTE: Some engines are built with a one-piece breather filter and some are built with a two-piece breather filter. Designs are not interchangeable.

Install One-Piece Breather Filter

1. Install breather disc and spring.
2. Install breather screen.
3. Install breather cover and secure with screws. Torque screws to 10 N·m (89 in. lb.).

Install Two-Piece Breather Filter

1. Install lower breather media into cavity, then install upper breather media.
2. Install breather disc and spring.
3. Install breather cover and secure with screws. Torque screws to 10 N·m (89 in. lb.).

Install Stator (if equipped)

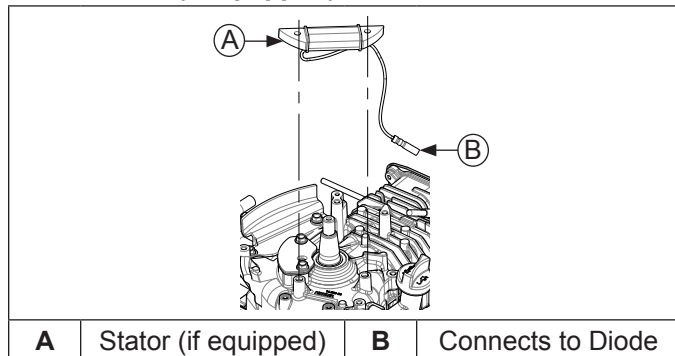

Position stator on crankcase with lead towards crankcase and routing where electric starter will be installed. Stator terminal connects to diode; move sleeving and connect terminal. Install and torque screws to 9.5 N·m (84 in. lb.).

Install Electric Starter (if equipped)

NOTE: Before installing starter, ensure that stator lead (if equipped) is in position between crankcase and where starter is located.

Align and mount electric starter onto crankcase. Install and torque screws to 9.5 N·m (84 in. lb.).

Install Flywheel

	<p>CAUTION</p> <p>Damaging Crankshaft and Flywheel can cause personal injury.</p>
<p>Using improper procedures can lead to broken fragments. Broken fragments could be thrown from engine. Always observe and use precautions and procedures when installing flywheel.</p>	

NOTE: Before installing flywheel make sure crankshaft taper and flywheel hub are clean, dry, and completely free of lubricants. Presence of lubricants can cause flywheel to be over stressed and damaged when mounting nut is torqued to specification.

NOTE: Make sure flywheel key is installed properly in keyway. Flywheel can become cracked or damaged if key is not properly installed.

NOTE: Always use a flywheel strap wrench to hold flywheel when tightening flywheel fastener. Do not use any type of bar or wedge to prevent flywheel from rotating, as these parts could become cracked or damaged.

1. Install key, into crankshaft keyway. Make sure key is fully seated.
2. Install flywheel onto crankshaft aligning keyway with key.
3. Align teardrop slot on fan with raised teardrop on flywheel. Align drive cup on flywheel, and install and hand tighten nut.
4. Using a flywheel strap wrench, hold flywheel still while simultaneously tightening nut to 51.5 N·m (38 ft. lb.).

Install Ignition Module

NOTE: If stud for mounting ignition module was not kept segregated from 2 studs for mounting fuel tank, compare their lengths and choose short one.

1. Rotate flywheel so ignition magnets are away from ignition module legs. Position ignition module on legs with kill tab down.
2. Loosely thread stud and screw into appropriate leg. Pull module away from flywheel and tighten stud to hold it in place. Rotate flywheel so ignition magnet is aligned with module.
3. Set air gap by placing a 0.254 mm (0.010 in.) plastic feeler gauge between magnet and module. Loosen stud and let magnet draw module against feeler gauge. Torque fasteners to 10 N·m (89 in. lb.).
4. Rotate flywheel to release feeler gauge, and check module does not come in contact with magnet. Recheck air gap.
5. Connect kill lead to ignition module kill tab.

Install Fuel Tank

1. Secure fuel tank to crankcase with screw. Torque screw to 8 N·m (71 in. lb.).
2. Secure top of fuel tank to crankcase by installing threaded studs. Torque studs to 10 N·m (89 in. lb.).
3. Install spacers on studs.

Install Flywheel Brake Spring

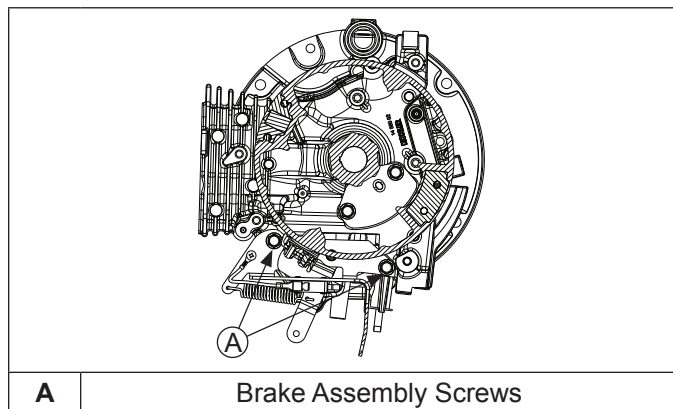

Using a pliers, attach flywheel brake spring onto bracket hook.

Reassembly

Install Governor Assembly

1. Install governor lever onto governor shaft with lever up.
2. Attach throttle linkage and linkage spring to top of governor lever.

Control Components

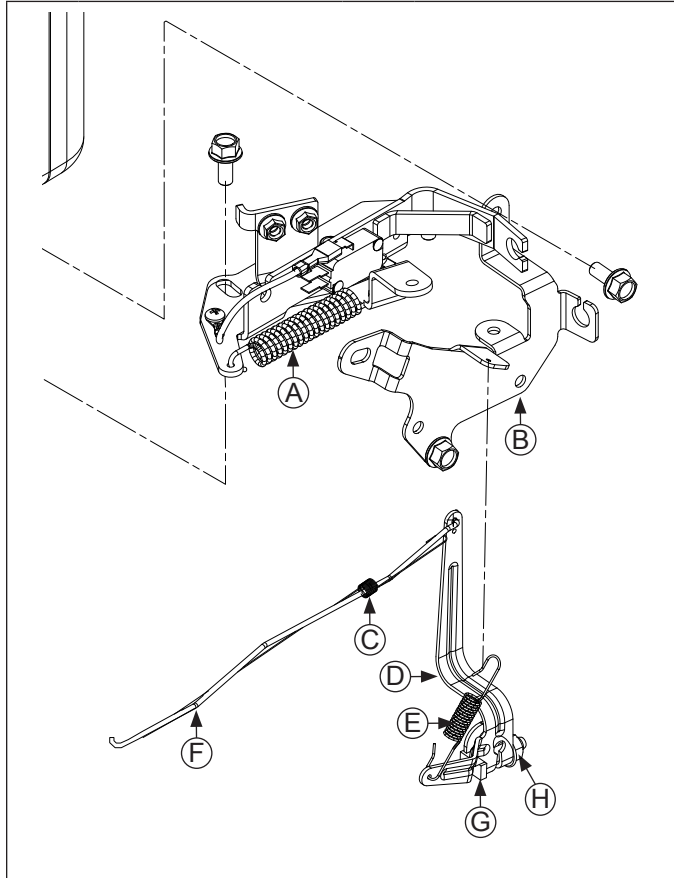

A	Flywheel Brake Spring	B	Fixed Speed Control Bracket
C	Linkage Spring	D	Governor Lever
E	Governor Spring	F	Throttle Linkage
G	Screw	H	Nut

Install Speed Control Bracket

NOTE: There are 3 different speed bracket variations for this engine. Images shown identify how different brackets connect to carburetors with and without choke.

Loosely attach speed control bracket to crankcase. On engines equipped with a fuel pump, fuel pump bracket secures on same stud as one leg of speed control assembly.

Speed Bracket Details

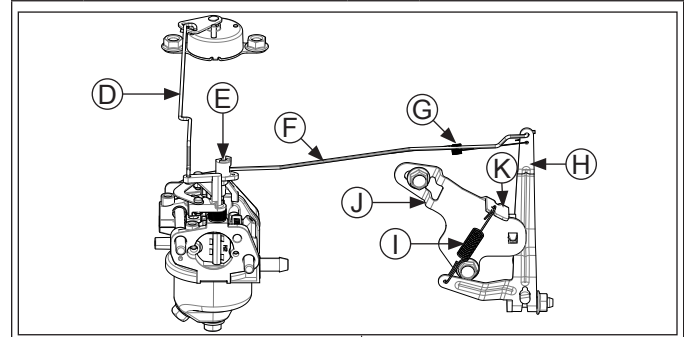

A

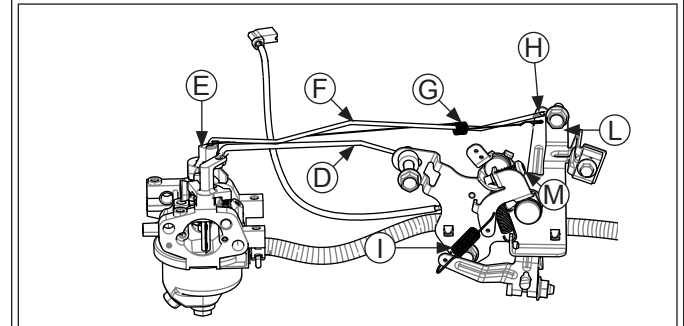

B

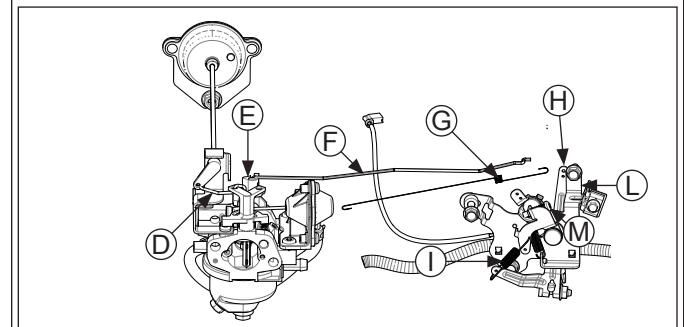

C

A	Fixed Speed with Auto Choke	B	Variable Speed with Standard Choke
C	Variable Speed with Auto Choke	D	Choke Linkage
E	Throttle Lever	F	Throttle Linkage
G	Linkage Spring	H	Governor Lever
I	Governor Spring	J	Fixed Speed Control Bracket
K	High Speed Adjustment Tab	L	Variable Speed Control Bracket
M	High Speed Adjusting Screw		

Install Governor Spring

Install governor spring between governor lever and speed control bracket.

Carburetor Components

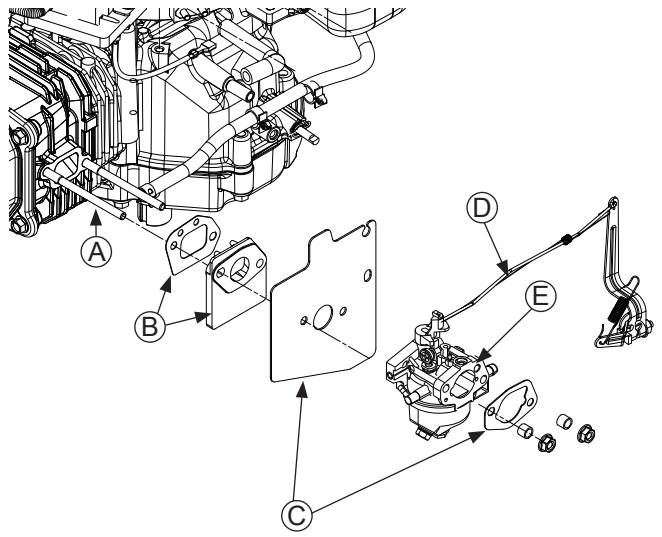

A	Carburetor Stud(s)	B	Gasket and Spacer Kit
C	Gasket and Heat Shield Kit	D	Linkage
E	Carburetor		

Install Carburetor Gaskets

Place spacer gasket, cylinder head spacer and heat deflector gasket on carburetor studs in order shown.

Install Carburetor and Linkage

NOTE: There are several different ways to attach carburetor linkage depending on carburetor and speed bracket used.

Install Carburetor with Standard Choke

1. With carburetor not yet mounted on studs, rotate it slightly and slot elbow, at end of linkage, into choke lever.
2. Connect throttle linkage and linkage spring to throttle lever on carburetor.
3. Slide carburetor onto mounting studs.

Install Carburetor with Auto Choke (if equipped)

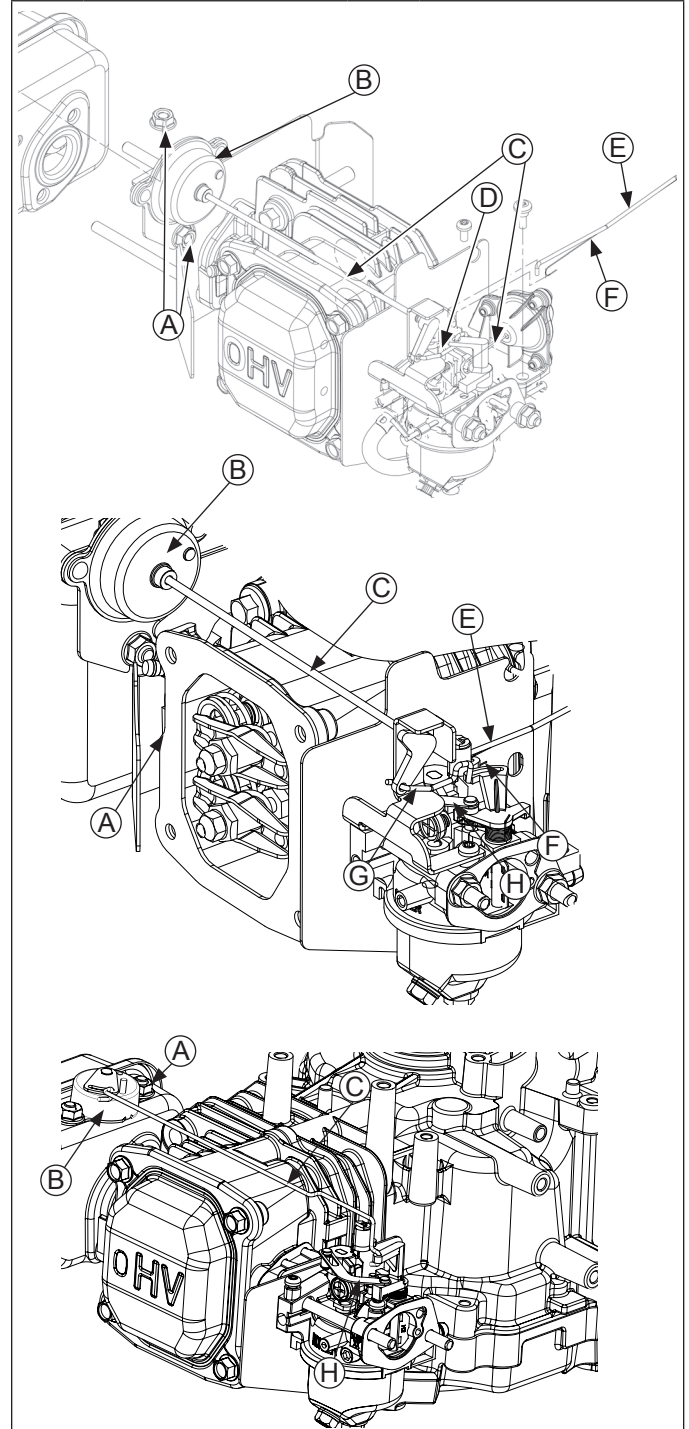

A	Nut(s)	B	Arm Assembly
C	Linkage	D	Choke Linkage
E	Governor Linkage	F	Linkage Spring
G	Wire Choke Linkage	H	Choke Link

1. Mount arm assembly onto muffler securing with nuts. Torque to 8.5 N·m (75 in. lb.).
2. Slide carburetor at least halfway onto mounting studs. Connect throttle linkage and linkage spring to carburetor.

Reassembly

3. Connect wire choke linkage while sliding carburetor to its seated position against engine.
4. Insert screws connecting arm assembly to carburetor. Torque to 2.3 N·m (20 in. lb.).

Adjust Governor

Move governor lever away from carburetor to limit of its travel (wide-open throttle), and hold in this position. Do not stress, flex or distort linkage. Grasp cross shaft with a pliers and turn shaft clockwise as far as it will go, hold and tighten nut. Torque nut to 9.5 N·m (84 in. lb.).

Reconnect Fuel Line

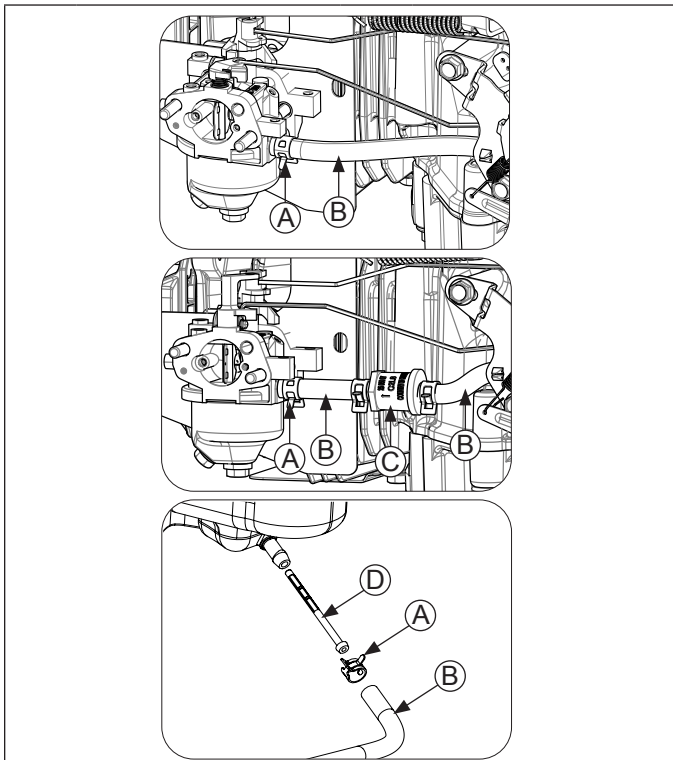

A	Hose Clamp	B	Fuel Line
C	Fuel Filter (if equipped)	D	In-Nipple Fuel Filter (if equipped)

1. Slide fuel line tight up against carburetor, and secure connection with a hose clamp.
2. Ensure that in-nipple fuel filter (if equipped) is in place in fuel tank outlet.
3. Connect fuel line to fuel tank and slide hose clamp to secure.

Install Fuel Pump (if equipped)

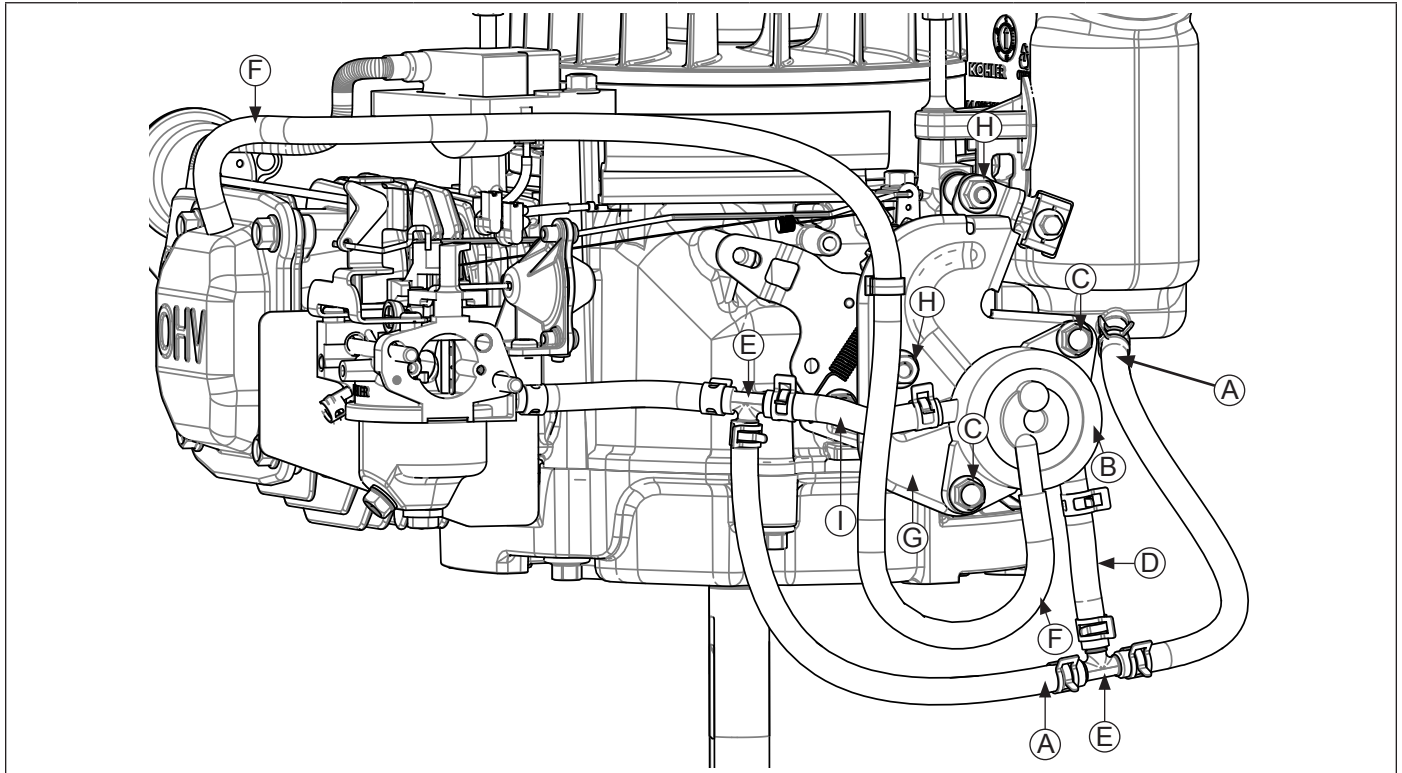

A	In-Nipple Fuel Filter	B	Fuel Pump	C	Screw	D	Inlet Fuel Line
E	Tee Fitting	F	Vent Hose	G	Fuel Pump Bracket	H	Nut
I	Outlet Fuel Line						

NOTE: If a new fuel pump is being installed, make sure orientation of new pump is consistent with removed pump. Internal damage may occur if installed incorrectly.

1. Connect vent hose to valve cover fitting.
2. Position fuel pump bracket on stud in crankcase and stud in speed control bracket. Secure with lock nuts. Torque nuts to 8 N·m (71 in. lb.).
3. Route vent hose through hose clip on fuel pump bracket.
4. Attach vent hose to fuel pump. Connect inlet and outlet fuel lines to pump. Position hose clamps to secure.
5. Secure fuel pump to fuel pump bracket. Torque screws to 2.3 N·m (20 in. lb.).

Reassembly

External Engine Components

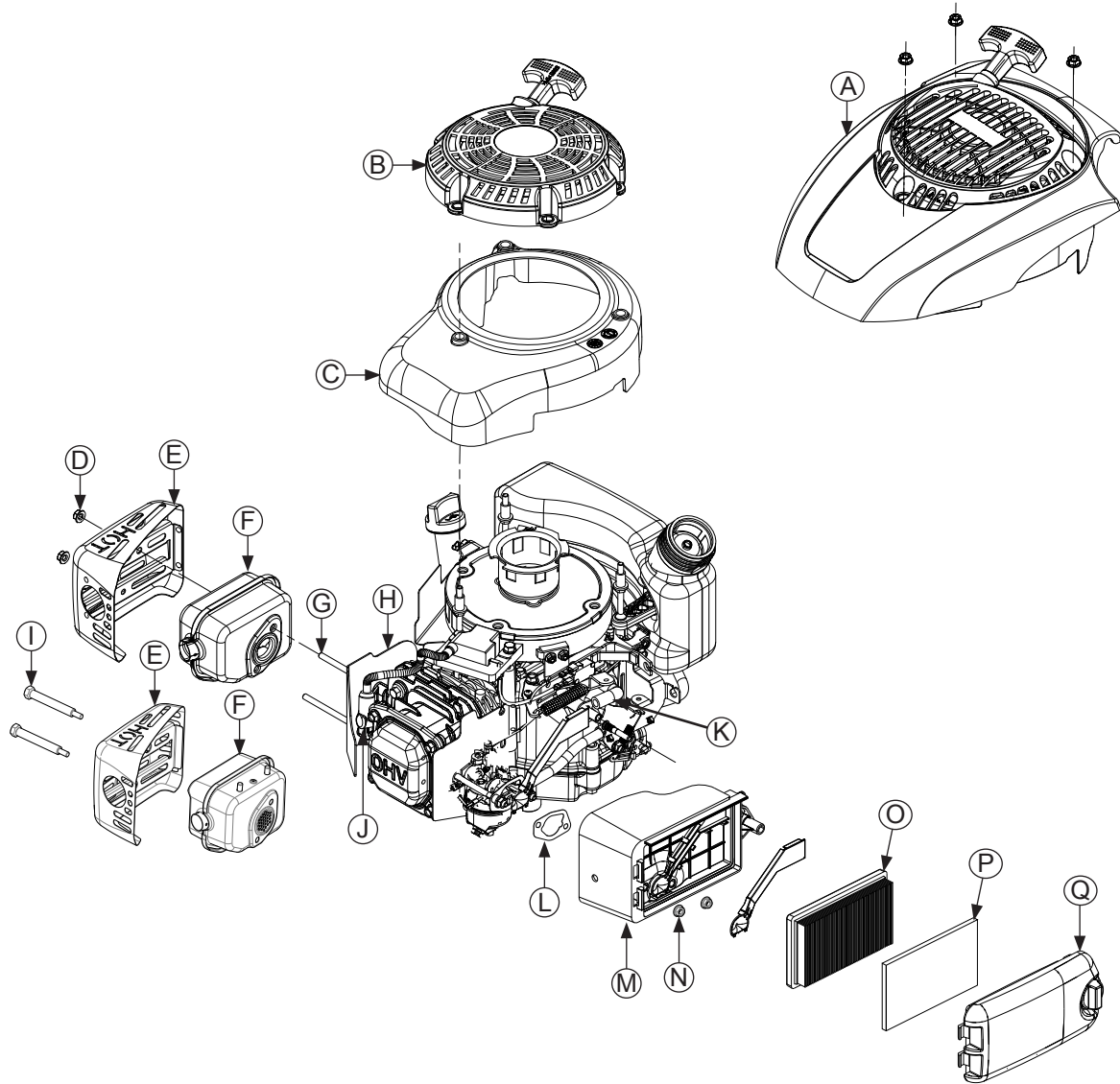

A	Engine Cover and Retractable Starter	B	Retractable Starter	C	Blower Housing	D	Lock Nut
E	Muffer Guard	F	Muffler	G	Exhaust Stud	H	Muffer Gasket (Heat Deflector)
I	Shoulder Screw	J	Spark Plug Lead	K	Breather Hose	L	Air Cleaner Base Gasket
M	Air Cleaner Base	N	Nut	O	Paper Element	P	Precleaner
Q	Air Cleaner Cover						

Install Air Cleaner Assembly

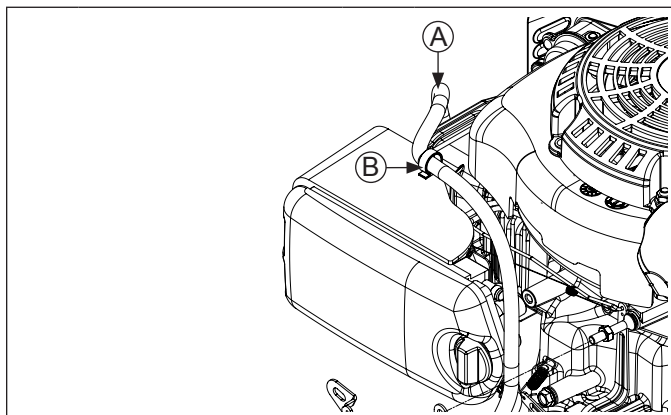

A	Vent Hose	B	Clamp
----------	-----------	----------	-------

1. Slide new air cleaner gasket onto carburetor studs.
2. Slide air cleaner base onto carburetor studs. Secure base by starting nuts onto studs and screw into crankcase.
3. If engine is equipped with fuel pump, carefully install clamp securing vent hose to top of air cleaner base.
4. Attach breather hose to crankcase.
5. Torque nuts and screw to 8 N·m (71 in. lb.).
6. Install paper element into air cleaner base. If equipped, install precleaner into air cleaner cover. Attach air cleaner cover and hand tighten knob.

Install Dipstick Tube (if equipped)

Insert dipstick tube into oil pan and secure to crankcase with screw. Torque screw to 8 N·m (71 in. lb.).

Install Muffler Assembly

NOTE: Muffler and guard is either secured with lock nuts on exhaust studs or with shoulder screws into exhaust port.

Lock Nuts/Exhaust Studs

1. Install heat deflector gasket onto exhaust mounting studs, with gasket folds facing cylinder head.
2. Slide muffler onto exhaust studs.
3. Install muffler guard onto exhaust studs and secure with nuts. Torque to 9.5 N·m (84 in. lb.).

Shoulder Screws

Position muffler and muffler guard on exhaust port and secure with shoulder screws. Torque to 9.5 N·m (84 in. lb.).

Install Blower Housing (if equipped)

Install blower housing onto studs.

Install Retractable Starter (if equipped)

Place retractable starter onto studs protruding from blower housing, secure with nuts. Torque nuts to 8 N·m (71 in. lb.).

Install Engine Cover and Retractable Starter (if equipped)

Install engine cover and retractable starter onto studs, secure with nuts. Torque nuts to 8 N·m (71 in. lb.).

Install Fuel Cap

Screw fuel cap tightly onto fuel tank.

Prepare Engine for Operation

Engine is now reassembled. Before starting or operating engine be sure to do following:

1. Make sure all hardware is properly torqued.
2. Make sure oil drain plugs are tightened securely.
3. Ensure crankcase is filled with correct oil.

Connect Spark Plug Lead

Connect lead to spark plug.

Testing Engine

NOTE: Engine can be installed in application and speeds can be checked/set.

NOTE: High speed and idle speed is listed for each engine specification in our online parts lookup system (www.Rehлкоplus.com site). This is listed in Attributes on Details tab of engine specification.

1. Run engine for 5-10 minutes between idle and mid-range. Adjust throttle and choke controls and high speed as necessary.

For engines with Fixed Speed, bend adjustment tab on speed control bracket up to increase or down to reduce speed. Refer to Speed Control Details earlier in this section.

For engines with Variable Speed, turn high speed screw on speed control bracket clockwise to decrease or counterclockwise to increase speed. Refer to Speed Control Details earlier in this section.

Make sure maximum engine speed does not exceed recommended RPM.

2. Adjust carburetor low idle speed screw so low idle speed is set to engine or application specifications. Refer to Fuel System.



1P14 690 10



8 85612 79292 1