

# Diesel Mobile Generators

90REOZT4, 120REOZT4, 145REOZT4 & 175REOZT4

## 1. Convenient Lifting Eye

- Single-point lifting
- Designed to carry the weight of the unit, tank, trailer and fuel

## 2. Stainless Steel Latches & Hinges

- Durable and corrosion resistant

## 3. Patented Easy-To-Remove Housing

- Remove bolts from base and lift off in one piece

## 4. Rehlko Decision-Maker 3500 Controller

- Rehlko-built controllers allow for single-source support and guaranteed system integration

## 5. Connection Panel

- Convenient cable connection point on rear of unit allows for either street or curbside access

## 6. On-Board Diesel Fuel System

- Minimum 24 hours of runtime @ 100% load
- Double-wall design for 110% containment

## 7. Commercial Trailer

- Rugged trailer with electric braking system

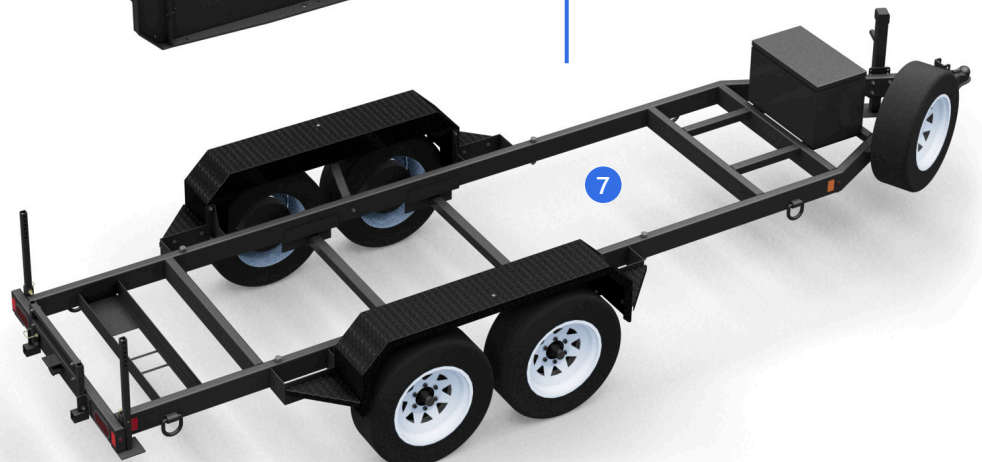
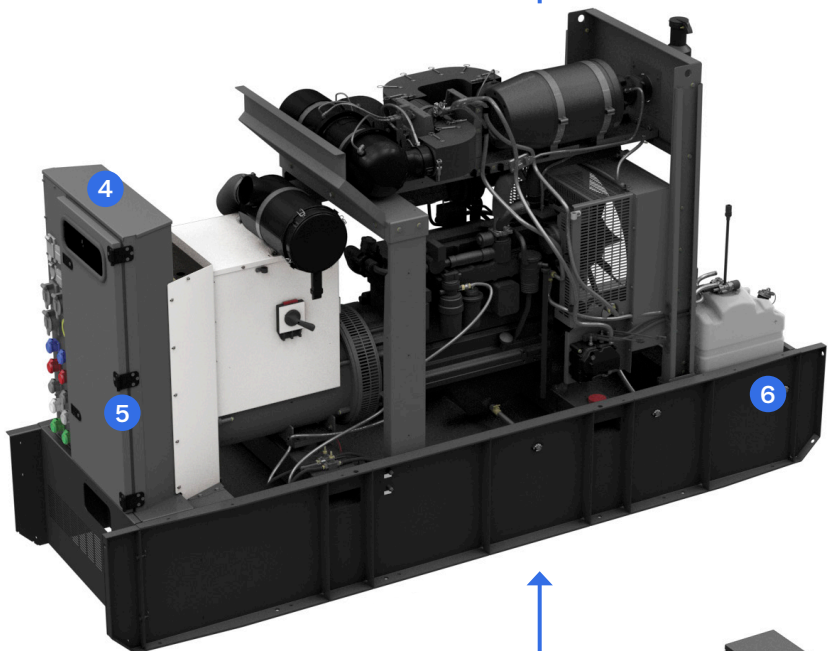

# Everything you need. *Nothing you don't.*

90REOZT4, 120REOZT4, 145REOZT4 & 175REOZT4 Diesel Mobile Generators

## Key Features

### Diesel Fuel System

- Connection ports and valve system tie into external fuel source for extended runtimes
- Double-wall tank for 110% environmental containment of fuel, oil and coolant

### Connection Panel



1. **Recessed Emergency Stop Button**
2. **Rehiko® Decision-Maker® 3500 Digital Controller**  
Fully encapsulated to protect from towing vibration
3. **Two 120 V, 15 A Duplex Outlets**
4. **Three 250 V, 50 A Outlets**
5. **Shore Power Receptacle**  
Uses alternate power source for battery charger & block heater
6. **Lockable Door**
7. **Cam Locks**  
Quantity varies based on generator output

### Rehiko Decision-Maker 3500 Controller

Our easy-to-use digital controller features advanced network communications for remote monitoring and diagnostics.

- Parallel-capable
- Color, 4.3-inch LCD display
- Remote-start and remote-stop functionality
- Potted circuit boards and sealed connectors protect against vibration and environmental conditions
- Paired with optional voltage selector switch, it auto-senses the switch setting, eliminating the need to program voltage changes
- Monitoring includes:
  - Voltage, current, frequency, power
  - Oil pressure & temperature, coolant pressure & temperature
  - Analog inputs, warnings and faults
  - EPA-required emissions data

### Controller Details



1. **Quick-Use Instructions**
2. **Graphical Display**
3. **Event Indication**
4. **Selector Dial**
5. **Alarm Silence/Lamp Test**
6. **Master Control Buttons**
7. **USB Plug**



Battery Disconnect

Battery Charger

Fuel Valve

## Standard Features

- **Battery Disconnect**  
Disconnects parasitic loads from the battery during storage
- **Battery & Battery Pack**
- **Oil Drain Extension**  
Provides connection point on skid to drain oil during oil changes
- **Load Lug Connections**  
Provides connection point for load cables
- **Remote Start/Stop Terminals**  
Allows remote start from ATS or remote start panel
- **Heavy-Duty Air Cleaner With Restriction Indicator**
- **External Emergency Stop**
- **Adjustable-Trip Mainline Circuit Breaker**
- **Premium Three-Year Limited Warranty**

## Optional Accessories

- **Voltage Selector Switch**
  - Allows easy switching between voltages
  - Lockable switch with padlock prevents voltage change while unit is running
  - Three-position switch: 120/208 V 3 Ph, 277/480 V 3 Ph & 120/240 V 1 Ph
- **Battery Charger**
  - Helps keep batteries at operating voltage
  - Recommended when generator is stored or not running for long periods of time
- **Fuel Valve**
  - Two-position valve allows user to draw from an external tank for more runtime
  - External ports on skid provide convenient fuel inlet and return connection points for external tank fittings
- **Cold Weather Package**
  - Includes block heater, battery heater pad, and battery wrap
  - Recommended where temperature frequently drops below freezing
  - Improves starting performance in cold weather conditions