

rehlko



Kohler Engines
is now Rehlko

Command PRO[®] 888

Gasoline Engines

29 – 32 hp | 21.6 – 23.8 kW

The Command PRO[®] 888 cc engines —
where unrivaled torque meets unmatched productivity.
Experience ferocious strength and complete control,
dominating every task.



The *beast* you need to *tame* your turf.

Discover the Command PRO® 888 engine, the latest generation of Rehlko carbureted gasoline engines in the 888cc class. Available in two versions—the CV829 with 29 hp and the CV832 with 32 hp— is designed as drop-in solution, ensuring seamless integration and optimal performance.

Witness the ferocious strength and unwavering reliability, even amidst the untamed wilderness. Command PRO® 888 sets the standard for powerhouse performance in its mid-block class. Tested to the extremes, it ensures sustained power, reducing downtime and extending service intervals for unmatched cost-efficiency.



UNRIVALED TORQUE
AND POWER DENSITY



OUTSTANDING
PRODUCTIVITY



LOWEST COST
OF OWNERSHIP

Command PRO® 888

Standard features

6-Inch heavy-duty air filter

Easily removable cleanout covers

High-efficiency fan and screen

20-Amp sealed charging regulated with over-voltage protection

Front-mount controls

Easily accessible service points

Full-pressure lubricant with filter and Oil Sentry™

Large dual drains hardened crank journals

Crank sleeved bearing on PTO

12-Volt solenoid shift starter

3-Year limited warranty

Variable timing electronic ignition

Solenoid fuel shutdown

Metal guard

EMC and RFI compliant

1 1/8-Inch diameter crankshaft

Popular factory options

25-Amp charging system

Engine mounted oil cooler



Command PRO® 888

29–32 HP Vertical-Shaft Engines*

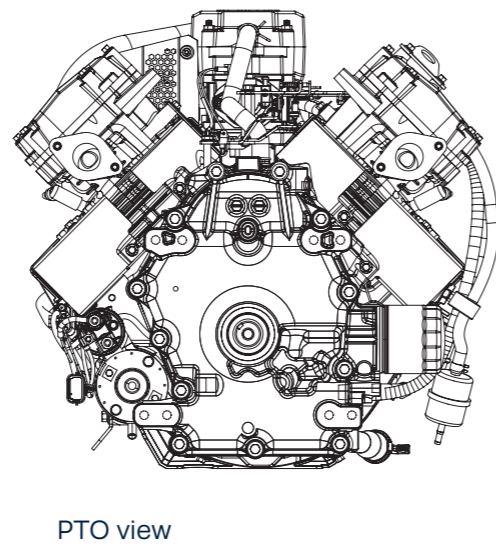
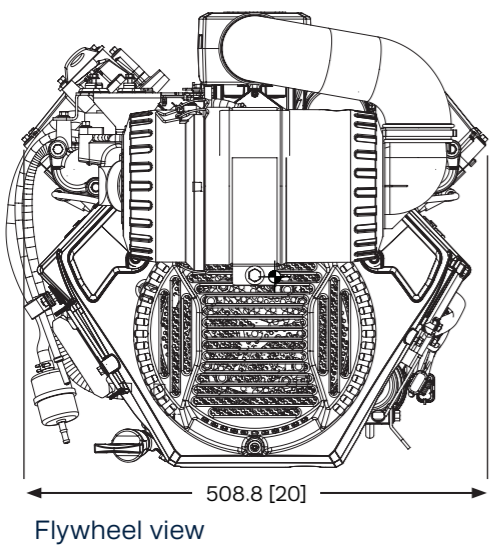
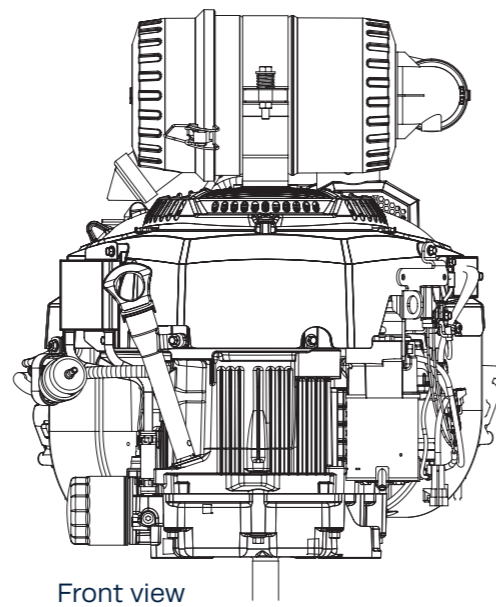
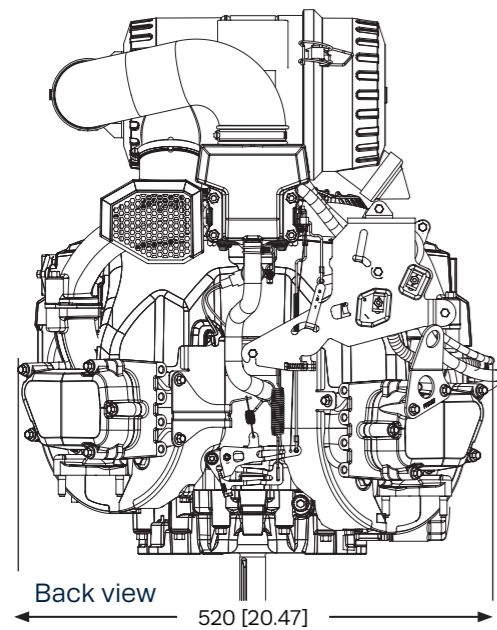

MODEL		CV829	CV832
POWER @ 3600 rpm	Max.hp (kW)	29 (21.6)	32 (23.8)
DISPLACEMENT	cc (cu in)	888 (54.2)	
BORE	in (mm)	3.4 (87)	
STROKE	in (mm)	2.9 (74.7)	
PEAK TORQUE @ rpm	ft-lb (Nm)	52.2 (70.8) @ 2400	53.1 (72.0) @ 2600
COMPRESSION RATIO		9.3:1	
DRY WEIGHT	lb (kg)	134 (61)	
OIL CAPACITY	U.S. qt (L)	2.0 (1.9)	
LUBRICATION		FULL-PRESSURE LUBRICATION WITH FULL-FLOW FILTER	
DIMENSIONS L×W×H	in (mm)	HEAVY-DUTY AIR CLEANER 20.0x13.8x23.8 (508x350x603)	

*Horsepower ratings meet Society of Automotive Engineers Small Engine Test Code J1940. Actual engine horsepower is lower and affected by, but not limited to, accessories (air cleaner, exhaust, charging, cooling, fuel pump, etc.), application, engine speed and ambient operating conditions (temperature, humidity and altitude).

Data

Dimensions mm [in]

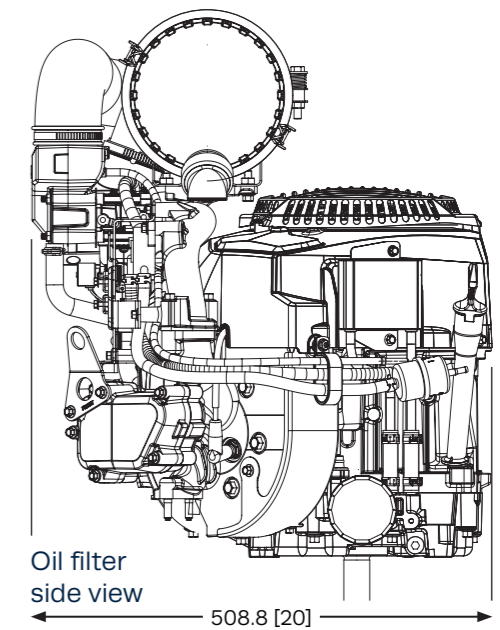
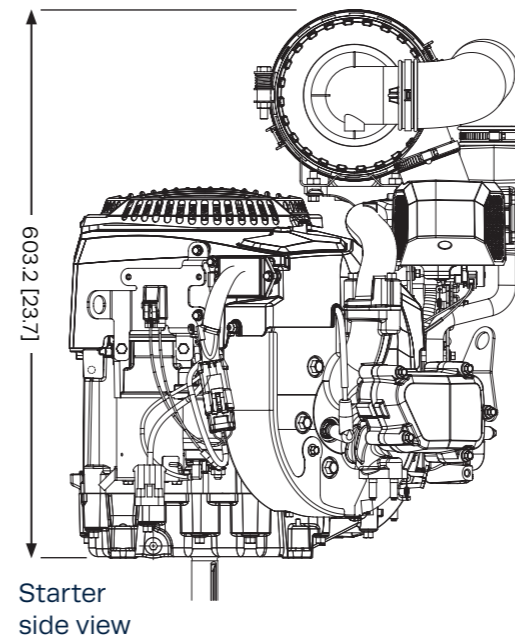

Performance curves

Rated 3600 rpm per SAE J1940

CV829
CV832

Maximum power

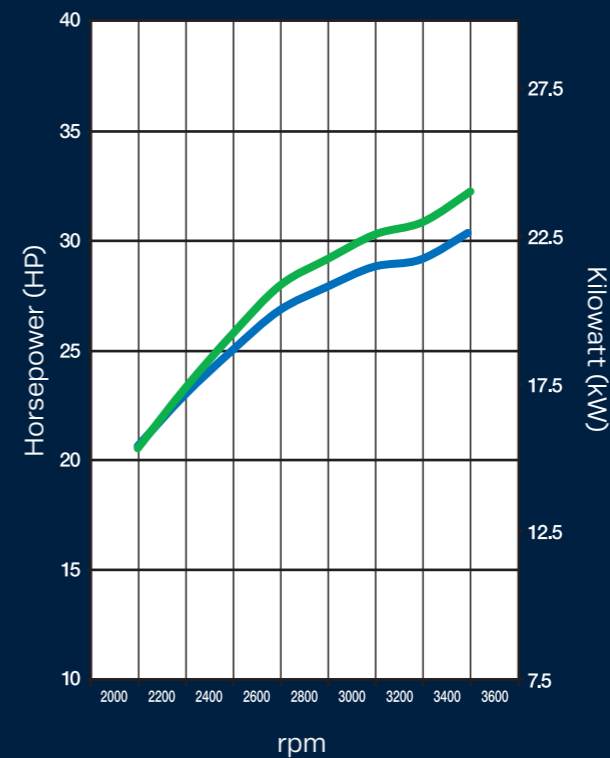

Maximum torque

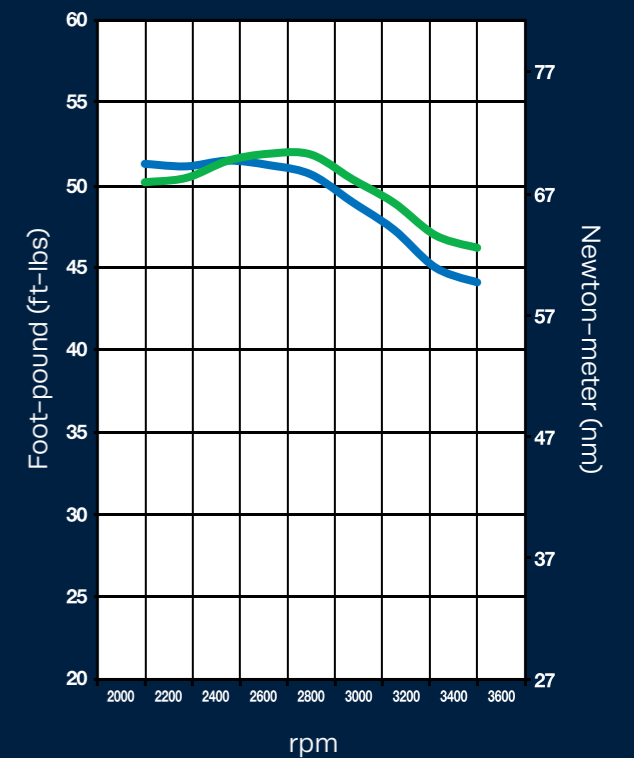

For more information, contact your Rehlko source of supply.
Discovery Energy, LLC reserves the right to make modifications without prior notice.



engines.rehlko.com

Printed in Italy ED0035586230 Rev.01 09/24 EN Discovery Energy, LLC